



Perceived Risk, Investment Performance and Intentions in Emerging Stock Markets

Phung Thai Minh Trang^{1*}, Nguyen Huu Tho²

¹Department of Accounting and Finance, Faculty of Economics and Commerce, Hoa Sen University, Ho Chi Minh City, Vietnam,

²Department of Finance-Project, Faculty of Business Administration, University of Economics, Ho Chi Minh City, Vietnam.

*Email: phungthaiminhtrang@gmail.com

ABSTRACT

The study built the new measurement scales of risk perception in investing in stock types trading on the emerging stock market, and then explored the effects of perceived risk on investment performance and intentions of individual investors. The study employed mixed research methods including in-depth interviews, a pilot study involving 50 investors, a survey distributed to 465 retail investors. Results showed that perceived risk had the direct positive impact on both investment performance and intentions. Perceived risk also had the indirect influence on intentions to invest through investment performance. For managerial decisions, investors are recommended to draw attention to the risks of investing in stocks labelled as “warned”, “controlled”, and “halted trading”. The higher investors perceive the risks of these stock types, the greater they are satisfied with their investment decisions, the recent rate of return achieved, and the more they intend to invest in the next time. Securities corporations have regularly organized seminars, workshops or training courses about investing in the kinds of stocks, updated regulations of stock investment in time, and improved the quality of listed companies to attract more investors to the stock market.

Keywords: Investment Performance, Intentions, Perceived Risk, Emerging Stock Markets

JEL Classifications: E44, G31

1. INTRODUCTION

Vietnam stock exchange, founded in 2000, consists of the Ho Chi Minh City (HCMC) stock exchange (HOSE) and the Ha Noi stock market (HNX). The share market capitalization reached VND 1,325,000 billion, approximately USD 62 billion, equivalent to 34 per cent of the Vietnam gross domestic product in 2015 (www.bnews.vn). Moreover, the total number of private investors' accounts in the Vietnam stock market was 1552 million in 2015 (www.baomoi.com). This number makes up such a small percentage of the overall Vietnamese population when Vietnam's current population is between 90 and 91 million. With improved policies, the Vietnam stock market has increasingly brought opportunities for investments. In fact, making investing decisions on intangible products is not easy and might base on psychology as Schwager (1993) quoted “trading is emotion; It is mass psychology, greed and fear” (p. 49). Additionally, Baker and Nofsinger (2010) also stated that we were all human beings, thus our behavior was

certainly affected by psychology. More importantly, “perceived risk” is considered as powerful instruments in investment since people seem to expect to prevent risk rather than maximize utility when making investing decisions (Mitchell, 1999).

“Perceived risk” has recently been studied in a number of fields such as online consumer product and service, e-banking, and stock markets. However, methods for assessing and measuring this perception are diverse. For instance, the domain of consumer goods focused on product risk, performance risk or financial risk (Dai et al., 2014; Forsythe and Shi, 2003), conversely, the internet banking industry related to social risk, time loss risk, opportunity cost risk, and information risk (Kassim & Ramayah, 2015). Interestingly, in the financial field risk perception was measured by attitude towards risk such as risk taking and risk aversion (Kahneman and Tversky, 1979; Barberis and Huang, 2001; Mayfield et al., 2008). Apparently, perceived risk of investing in types of stocks trading on the stock market has yet

to be explored; particularly its direct and indirect impact on investment performance and intentions have not been studied in Vietnam. Hence, three key research questions are raised: “What new measurement scales of perceived risk are explored?”; “to what extent does “perceived risk” directly influence investment performance and intentions?”; “to what extent does “perceived risk” indirectly influence investment intentions through investment performance?” In addition, The main objectives are Firstly to build the new measurement scales of perceived risk of investing stock types on the Vietnam stock market. Secondly, to test the study test the validity and reliability of the new scales, and then to explore the direct and indirect effects of perceived risk on investment performance and intentions.

2. LITERATURE REVIEW

2.1. Consumer Behavior and Perceived Risk

Consumer behavior is defined as “the process and activities people engage in when searching for, selecting, purchasing, using, evaluating, and disposing of products and services so as to satisfy their needs and desires” (Belch and Belch, 2003. p. 105). Howard and Sheth (1969) initially developed the model of consumer behavior and eventually became the “theory of buyer behavior.” The theory is widely used since it has given a sophisticated combination of the diverse social, psychological, and marketing impacts on buyer choices (Foxall, 1990). Bauer (1960), initially stated that perceived risk was involved only in subjective risk. Perceived risk is defined as “in the sense that any action of a consumer will produce consequences which he cannot anticipate with anything approximating certainty, and some of which at least are likely to be unpleasant” (Bauer, 1960). Perceived risk is also considered as “the citizen’s subjective expectation of suffering a loss in pursuit of a desire outcome” (Warkentin et al., 2002. p. 160).

2.2. The Theory of Planned Behavior (TPB) and Intentions

The TPB derived from the reasoned action theory is “open to the inclusion of additional predictors if it can be shown that they capture a significant proportion of the variance in intention or behavior after the theory’s current variables have been taken into account” Ajzen (1991. p. 199). This theory proposes that an individual’s attitude toward a behavior, subjective norms, and perceived control can influence intentions (Ajzen, 1991). An attitude toward a behavior is considered as one’s assessment of the given behavior based on his/her beliefs; a subjective norm relates to one’s perception; perceived control concern the perceived difficulty to carry out the behavior (Ajzen, 1991). This theory provides a model which can predict one’s behavior via intentions defined as individual perception towards likelihood to conduct behavior (Ajzen and Fishbein, 1980).

2.3. Recent Research of Perceived Risk, Investment Performance and Investment Intentions

Kassim and Ramayah (2015) studied the relationship among perceived risk factors and intentions to continue using internet banking in Malaysia. These authors found that social risk, time loss risk, opportunity cost risk, and information risk, all significantly affected the attitude towards the use of internet banking. Also, it

was learned that functional risk, physical risk and financial risk had no significant impact on this attitude. In addition, attitude towards the use of electronic banking (e-banking) had a positive influence on intention of using internet banking in the future.

Cuong and Jian (2014) explored attitude toward the behavior such as overconfidence excessive optimism, herd behavior, and psychology of risk positively affected behavior intention to decision-making of individual investors on the Vietnam stock market. This result was consistent with other scholars such as Gervais et al. (2002), Johnsson et al. (2002).

Dai et al. (2014) explored that perception of product risk had the strong impact on online purchase intentions for both digital and non-digital products. The findings were similar to Forsythe and Shi (2003)’s. However, the financial risk affected online purchase intentions for non-digital products only while Bhatnagar et al. (2000), Chang et al. (2005), and Forsythe et al. (2006) gave results of this impact for both digital and non-digital ones. Likewise, privacy risk had no impacts on buying intentions for both kinds of products, whereas online safety had the strong influence strong influence in researches of Miyazaki and Fernandez (2001) and Noort et al. (2008). Different consequences could be caused by different respondents.

Alleyne and Broome (2011) also studied future investors who were currently business students in an undergraduate institution. More impressively, these authors added risk propensity as an independent variable to three independent variables in TPB. Four predictors consisted of attitude toward the behavior, subjective norms, perceived behavioral control, and risk propensity positively affected intentions to invest. This exploration matched results of East (1993) and Gopi, Ramayah (2007).

Oberlechner and Osler (2008) used primary data: a survey distributed to 416 current market professionals in North America and found the significant relationship between behavioral finance, overconfidence and investment performance. Lin and Swanson (2003) used secondary data to explore the significant relationship between trading behavior and investment performance of foreign investor trading on the Taiwan stock market. These authors measured the outcome variable through three dimensions such as raw returns, returns adjusted from risk or momentum. In addition, Kim and Nofsinger (2003) also showed that possessing risky stocks, purchasing current winners, influenced performance of Japanese individual investors.

3. RESEARCH METHODS AND MODELS

The article employed mixed research methods: Qualitative and quantitative with techniques comprising in-depth interviews and survey. Specifically, the study firstly applied in-depth interviews which lasted for six weeks to six brokerage managers who each have 10 years of experience in financial investment. The aim of these interviews is to explore the new measurement scales of perceived risk. These brokerage managers are working for top securities corporations in Vietnam such as HCMC Securities Corporation, Rong Viet Securities Corporation, Bao Viet Securities

Corporation, and Thien an Viet Commerce and Investment Joint Stock Company. Secondly, the authors used the following five-point Likert scale survey questions: Perceived risk explored by authors of this study, investment performance from Oberlechner and Osler (2008), and investment intentions from Dodds et al. (1991) and Soderlund and Ohman (2003). Thirdly, the pilot study was distributed to 50 investors with the aim of testing the reliability of all items of variables. Finally, the questionnaires were sent to 480 private investors trading on the Vietnam stock exchange, and 465 valid returned ones. The survey spanned 8 months with strong support from securities corporations.

The study used SPSS and AMOS software for exploration factor analysis (EFA) with principal axis factoring for extraction method and Promax with Kaiser normalization. Confirmation factor analysis (CFA) and structural equation modeling (SEM) were applied for exploring the effects of perceived risk on investment performance and intentions. The authors applied SEM model for the research since SEM is “a family of statistical models that seek to explain the relationships among multiple variables” (Hair et al., 2014, p. 546). Additionally, SEM can examine a series of dependence relationships simultaneously as well as is useful to know how to spot an exogenous and endogenous construct.

For testing the reliability of variables, Hair et al. (2014) suggests that Cronbach’s alpha should be from 0.6; the Kaiser–Meyer–Olkin and Bartlett’s test should be more than 0.6 and the accepted significant level (P) is not more than 0.05. Initial Eigen value should be >1 and cumulative percentage is not <50%. FLs of the items on a factor are >0.3, the corrected item-total correlation index is 0.3 and the rotation sums of squared loadings is suggested to be more than 50%. After loading factors, the following tests of measurement theory validation with CFA are:

3.1. Unidimensionality

Multiple fit indices should be used to assess a model’s goodness-of-fit (GOF) and include: The value of Chi-square (χ^2) # 0, and $P \leq 0.05$; the associated df: $\chi^2/df \leq 0.5$; one incremental fit index: Comparative fit index ≥ 0.8 ; Tucker Lewis Index (TLI) ≥ 0.8 ; one GOF index: GFI ≥ 0.8 ; TLI ≥ 0.8 ; one badness-of-fit index: Root mean square error of approximation (RMSEA) ≤ 0.08 . Details are presented in Appendix.

3.2. Construct Validity

Validity is defined as the extent to which research is accurate. First, FLs: Standardized loading estimates should be 0.5 or higher; second, convergent validity: Average variance extracted (AVE) should be 0.5 or greater to suggest adequate convergent validity. Construct reliability should be 0.6 or higher to indicate adequate convergence or internal consistency. Third, discriminant validity: Compare the AVE values for any two constructs with the square of the correlation estimate between these two constructs.

Model diagnostics: Standardized residuals are less than |2.5| do not suggest a problem, but greater than |4.0| suggest a potentially unacceptable degree of error that may call for the deletion of an offering item. Standardized residuals for any pair of item between |2.5| and |4.0| deserve some attention, but may not suggest any

changes to the model if no other problems are associated with those two items. Standardized residual covariance is not more than |2|. Modification indices (MI) of approximately 4.0 or greater suggest that the fit could be improved significantly by freeing the corresponding path to be estimated.

3.3. Model Testing

This study established the SEM for path analysis: Exogenous construct: Perceived risk labeled as PERISK and endogenous constructs: Investment performance (INVEST) and intentions (INTENT). A path diagram of specific hypothesized structural relationships and measurement specification are shown in Figure 1.

Basing on overall perceived risk relevant to product specific risk and product class risk (Dowling and Staelin, 1994) and the results from in-depth interviews, this study explored types of stocks trading on the stock market. The study expects to have the positive correlation between perceived risk and investment performance. This relationship might be written under the following equation:

$$\text{INVEST}_i = \alpha + \beta_1 \text{PERISK}_i + \varepsilon_i \quad (1)$$

Where, INVEST: Investment performance, PERISK: Perceived risk, i: i^{th} investor.

Perceived risk of individual investors is considered as one’s attitude toward a behavior in TPB (Ajzen, 1991). Many scholars explored the effects of perceived risk on intentions to invest (Cuong and Jian, 2014; Alleyne and Broome, 2011; Gopi and Ramayah, 2007; East, 1993). However, risk perception focused on types of stocks seems to be new ideas. The study, therefore, proposes a model of this impact shown under the equation below:

$$\text{INTENT}_i = \mu + \ell_1 \text{PERISK}_i + \theta_i \quad (2)$$

Where, INTENT: Investment intentions, PERISK: Perceived risk, i: i^{th} investor.

Gopi and Ramayah (2007) mentioned high earnings/return as an item in “attitude toward the behavior” that had the positive influence on intentions to use online stock trading. This consequence was likely to be similar to East (1993)’s and Alleyne and Broome (2011)’s. In practice, if one is satisfied with his/her earnings/return, it seems to be certain that he/she will invest in stocks in the next time. Thus, the model relevant to this relationship might be presented under the equation below:

$$\text{INTENT}_i = \sigma + v_1 \text{INVEST}_i + \delta_i \quad (3)$$

Where, INTENT: Investment intentions, INVEST: Investment performance, i: i^{th} investor.

The TPB has been studied by many a scholar with a number of domains such as consumer products, banking, finance, investment. More notably, behavior intention has been considered as a dependent variable over the past decades (Ajzen, 1991; Dodds et al., 1991; East, 1993; Soderlund and Ohman, 2003), but “perceived risk” of this study is the new independent variable.

Figure 1: A path diagram of perceived risk, investment performance and intentions

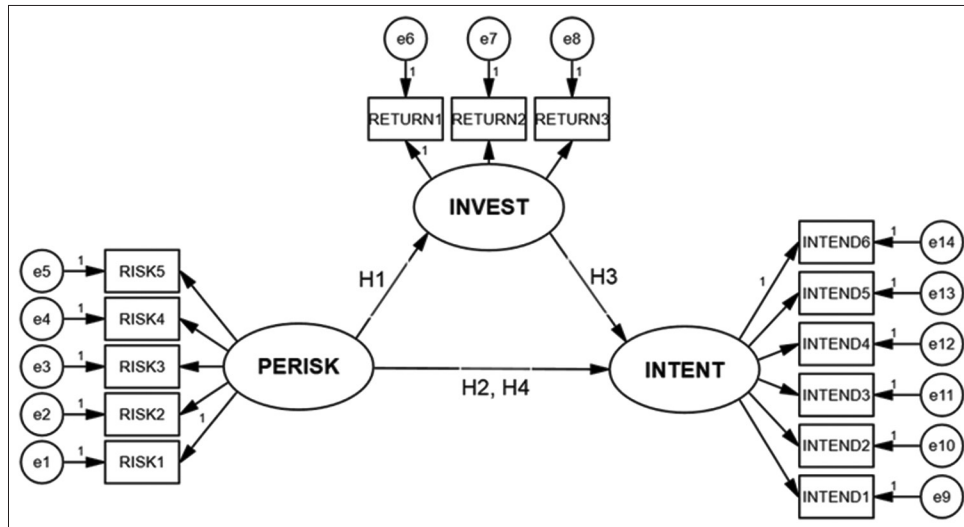

As a result, the authors also suggest considering intentions as the outcome variable and testing the effects of perceived risk and investment performance on intentions to invest. The equation might be indicated as follows:

$$INTENT_i = \psi + \gamma_1 PERISK_i + \gamma_2 INVEST_i + \pi_i \quad (4)$$

Where, INVEST: Investment performance, INTENT: Investment intentions, PERISK: Perceived risk, i: ith investor.

3.4. Scope of the Research and Sample Size

3.4.1. Scope of the research

Vietnam has 63 provinces, two stock exchanges including HNX and HOSE, and three key cities HCMC, Ha Noi City, and Da Nang City. HCMC is the largest City and represented for the South; Ha Noi City as the Capital is behalf on the North; and Da Nang City as the central Vietnam. Questionnaires were sent to individual investors living in cities of Vietnam, but in these main areas more than others since these cities are the heart of Vietnam’s economy.

3.4.2. Sample size for interviews

The question has repeatedly been raised that how many interviews are needed in a qualitative research? In practice, there is no sampling rule and “the specific number will depend on the complexity of the research questions and of the interview topic guide, the diversity of the sample and the nature of the analysis” (Francis et al., 2010. p. 1234). A researcher will stop collecting data if one reaches “saturation” defined as “the point at which no new relevant information is forthcoming even if more people are interviewed” (Galvin, 2015. p. 3). However, to be more conceivable, the authors used the formula of small sampling of qualitative data proposed by Galvin (2015) as follows:

$$n = \frac{\ln(1 - P)}{\ln(1 - R)}$$

Where, n: The number of interviews, P: Level of confidence, R: Proportion of the population.

The study needs to be at least 95% confident that all the issues have emerged which are represented in 40% of the population because of brokerage managers living in HCMC. After computing, the number of interviewees required was 6.

3.4.3. Sample size for surveys

The number of investors who actually traded on the Vietnam stock market in 2015 was around one million five hundred (1.5 million) (www.baomoi.com). The study employed the formula of Krejcie and Morgan (1970) to calculate the sample size as follows:

$$S = \frac{\chi^2 NP(1 - P)}{d^2 (N - 1) + \chi^2 P(1 - P)}$$

Where,

S = Required sample size;

χ^2 = The table value of Chi-square for 1 degree of freedom at the desired confidence level (3.841);

N = The population size;

P = The population proportion (assumed to be 0.50 since this would provide the maximum sample size);

d = The degree of accuracy expressed as a proportion (0.05).

Basing on the formula above, the sample size required was 384. The number of investors requested to ensure the reliability and validity of the study was consistent with suggestions of Hair et al. (2014) “minimum sample size – 300 for models with seven or fewer constructs” (p. 574). Sample size for the pilot test was 50 private investors. Then, 480 questionnaires were sent to individual investors and only 465 returned valid questionnaires.

4. THE FINDINGS

4.1. Findings of the New Measurement Scales

The authors initially interviewed six brokerage directors working for top securities corporations in Vietnam and explored the new measurement scales of perceived risk. Five types of stocks trading on the Vietnam stock market include: (1) Stocks labeled as

“warned”; (2) stocks labeled as “controlled”; (3) stocks that have halted trading or suspended trading; (4) highly speculative stocks; (5) blue chip stocks, fund certificates, or VN30 indexed stocks. Five questions with 5-point Likert scales, from totally disagree to totally agree, concerned with perceived risk are proposed as follows:

- RISK1: I feel it is risky to invest in stocks labeled as “warned”
- RISK2: I feel it is risky to invest in stocks labeled as “controlled”
- RISK3: I feel it is risky to invest in stocks that have halted or suspended trading
- RISK4: I feel it is risky to invest in highly speculative stocks
- RISK5: I feel it is risky to invest in blue chip stocks, fund certificates or VN30 indexed stocks.

Next, defining individual constructs based on published literature review and interviews with brokerage managers, the study emphasized on three key constructs below:

- Perceived risk (PERISK): The extent to which investors perceive risk of investing in types of stocks trading on the stock market
- Investment performance (INVEST): The extent to which investors are satisfied with the rate of return of recent stock investment compared to their expectation as well as with the investment decisions
- Investment intentions (INTENT): The extent to which investors intend/plan/want/would like to invest in stocks in the next time.

Finally, the test of face validity was performed as follows: the experts - interviewees proposed a set of multiple-item reflective scales to assess each construct. The conceptual definitions also matched well with the item wordings. Moreover, a pretest was carried out where judges of items of three variables were suitable for the construct names. After establishing face validity, the study proceeded to finalize the scales by pretesting involving 50 investors, and then, a survey distributed to 465 investors. The results were presented below.

4.2. Respondent Description

As Table 1 presented participant information, there were 465 individual investors, trading on the Vietnam stock market who were male was 58.8% of the total sampling. Most of them, 51.2% were from 26 to 35 years old. 70.9% of the total participants achieved university degree, 44.9% from 6 to 12 million per month. 49.1% of them had <5 years of work experience and 31.6% owned 1-3 years of seniority of stock investment. Individual investors took training courses of investment stocks, taking 63.5% and 26.7% investors used from 100 to 300 million VND for their stock investment (Table 1).

4.3. EFA Results

4.3.1. Results of reliability test

The study applied 5-point Likert scales: 1 point for totally disagree and 5 points for totally agree. The construct of PERISK included 5 items; 3 items involving the construct of INVEST, and the construct of INTENT owned 3 components. Moreover, the Cronbach’s alpha of three variables was >0.7 (Table 2).

Table 1: Summary of respondents’ characteristics with highest percentage

Characteristics	Percentage
Male	58.8
Age: 26-35	28.4
University degree	70.9
Income level: 6-12 million	44.9
Work experience: <5 years	49.1
Seniority of stock investment: 1-3 years	31.6
Training courses: Yes	63.5
The amount of investment: 100-300 million VND	26.7

4.3.2. Results of FLs

With extraction method: Principal axis factoring and rotation method: Promax with Kaiser Normalization, EFA results divided all items into three groups. Namely, the first group labeled as INTENT included INTEND3, INTEND4, INTEND2, INTEND1, INTEND5, and INTEND6; the second group named PERISK involved RISK1, RISK2, and RISK3; the final factor entitled INVEST covered three items such as RETURN1, RETURN2, and RETURN3. These FLs met standardized FLs >0.7, variance-extracted measures exceed 70% (74.776%) (Table 3).

4.4. Assessing the Structural Model Validity

4.4.1. Overall fit

Most GOF indices were within a range that would be associated with good fit. Firstly, the overall model, Chi square (χ^2), was 99.566 with degrees of freedom. The P value associated with this result was 0.000 (P < 0.05). Secondly, the value for RMSEA, an absolute fit index, was 0.045 below the 0.08 guideline for a model with 12 measured variables and a sample size of 465. Using the 90% confidence interval for this RMSEA, the study concluded the true value of RMSEA was between 0.032 and 0.058. Next, the standardized root mean square residual with a value of 0.0212 was below the conservative cut-off value of 0.05. Lastly, the normed (χ^2) of 1.952 was considered very well. These diagnostics suggested the model provides a good overall fit. Details were presented in Table 4 and Appendix.

4.4.2. Convergent validity

Table 5 displayed standardized loadings or standardized regression weights using AMOS terminology. The lowest loadings obtained 0.706, linking INVEST to item RETURN2. The AVE estimated and the construct reliabilities were shown at the bottom of Table 5. The AVE estimated range from 54.6% for INVEST to 85.6% for PERISK, in which all exceeded the 50 per cent. Construct reliabilities ranged from 0.78 for INVEST to 0.95 for PERISK, and 0.96 for INTENT, which exceeded 0.7, and suggested adequate reliability. Taken together, the evidence supported the convergent validity of the measurement model, and the model fitted relatively well. Hence, all the items were retained at this point and adequate evidence of convergent validity was provided.

4.4.3. Discriminant validity

Table 6 showed AVE of all variables was greater than the estimated correlation. Namely, AVE of PERISK of 0.9 was greater than the estimated correlation between PERISK and INTENT (0.197), and INVEST (0.16). Likewise, AVE of INTENT of 0.8 was greater

Table 2: Item description and Cronbach’s alpha of all variables

Item	Scale type	Description	Construct	Cronbach’s alpha
RISK1	1-5 Likert	I feel it is risky to invest in stocks labeled as “warned”	PERISK	0.747
RISK2	Above	I feel it is risky to invest in stocks labeled as “controlled”	PERISK	
RISK3	Above	I feel it is risky to invest in stocks that have halted or suspended trading	PERISK	
RISK4	Above	I feel it is risky to invest in highly speculative stocks	PERISK	
RISK5	Above	I feel it is risky to invest in blue chip stocks, fund certificates or VN30 indexed	PERISK	
RETURN1	Above	The return rate of my recent stock investment meets my expectation	INVEST	0.781
RETURN2	Above	My rate of return is equal to or higher than my last rate of return	INVEST	
RETURN3	Above	I feel satisfied with my investment decisions	INVEST	
INTEND1	Above	I intend to invest in shares in the next time	INTENT	0.958
INTEND2	Above	I plan to invest in shares in the next time	INTENT	
INTEND3	Above	I want to invest in shares in the next time	INTENT	
INTEND4	Above	There is a high probability I will invest shares in the next time	INTENT	
INTEND5	Above	I am likely to invest in shares in the next time	INTENT	
INTEND6	Above	I would like to invest in shares in the next time	INTENT	

Table 3: Summary of FL of items

Group 1	FL	Group 2	FL	Group 3	FL
INTEND3	0.939	RISK1	0.957	RETURN1	0.769
INTEND4	0.895	RISK2	0.926	RETURN2	0.731
INTEND2	0.893	RISK3	0.892	RETURN3	0.714
INTEND1	0.885				
INTEND5	0.878				
INTEND6	0.846				

FL: Factor loadings

Table 4: GOF measurers of the research model

GFI	The research model
Chi-square (χ^2)	
Chi-square	99.566
Degree of freedom	51
P	0.000
Absolute fit measures	
GFI	0.965
RMSEA	0.045
90% confidence interval of RMSEA	0.032-0.058
RMR	0.019
SRMR	0.0212
Normal Chi-square	1.952
Incremental fit indices	
NFI	0.979
TLI	0.987
CFI	0.99
RFI	0.973
Parsimony fit indices	
AGFI	0.946
PNFI	0.757

GFI: Goodness-of-fit index, RMSEA: Root mean square error of approximate, RMR: Root mean square residual, SRMR: Standardized root mean residual, NFI: Normed fit index, NNFI: Non-normed fit index, TLI: Tucker-Lewis index, CFI: Comparative fit index, RFI: Relative fit index, AGFI: Adjusted goodness-of-fit index, PNFI: Parsimony normed fit index

than its correlation with INVEST (0.39). Therefore, this test indicated that there were no problems with discriminant validity for the research model.

4.4.4. Standardized residual covariance

Standardized residual covariance are analogous to Z scores and most should have a value under |2| or |2.58| (Byrne, 2013). In

Table 7, all standardized residual covariance had values under |2| which met the standards of good measurement practice and appeared to hold quite well.

4.4.5. MIs

As Table 8 showed, most of the values above 4.0 were associated with the items in the construct and there were no large values for the variables. It concluded that the model had a solid theoretical foundation and questionnaire measured these key construct well.

4.5. Results of Testing Models

After testing the reliability and validity of the research model, the study used SEM with AMOS software to find out results. All the assumptions were supported and demonstrated in Figure 2.

The first model, H1, was supported. The following equation might be demonstrated as follows:

$$INVEST_i = 0.16PERISK_i^{**} \tag{1'}$$

The equation (1’) showed that PERISK positively affected INVEST. Specifically, the standardized coefficient for PERISK was 0.16 (**P < 0.01) in which it can be mathematically interpreted that for every additional 1% of PERISK, INVEST will increase by 16%. In other words, the higher investors perceive risks of investing in stocks labeled as “warned,” “controlled” or stocks that have halted or suspended trading, the greater they are satisfied with their investment decisions or the recent rate of return achieved. This consequence is consistent with previous research conducted by Oberlechner and Osler (2008) and Lin and Swanson (2003).

The result also supported the second model. The equation may be written as follows:

$$INTENT_i = 0.14PERISK_i^{**} \tag{2'}$$

PERISK positively influenced INTENT with the standardized coefficient for PERISK at 0.14 (**P < 0.01) as the equation (2’) presented above. It can be explained that an increase of

1 standard deviation in PERISK will increase by 14 standard deviations of INTENT. In effect, if investors enhance the level of risk perception of investing in stocks labeled as “warned,” “controlled” or stocks that have halted or suspended trading, they

will have more plans to invest in stocks in the future. This finding is similar to previous researches of scholars such as Kassim and Ramayah (2015), Cuong and Jian (2014), Dai et al. (2014), Alleyne and Broome (2011).

Table 5: Standardized FL, AVE, and reliability estimates

	INTENT	PERISK	INVEST
INTEND4	0.897		
INTEND2	0.898		
INTEND1	0.888		
INTEND5	0.878		
INTEND6	0.866		
INTEND3	0.914		
RISK2		0.952	
RISK1		0.925	
RISK3		0.897	
RETURN3			0.792
RETURN1			0.716
RETURN2			0.706
AVE	79.3%	85.6%	54.6%
CR	0.96	0.95	0.78

AVE: Average variance extracted, CR: Construct reliability, FL: Factor loadings

Table 6: AVE and correlation estimates

	PERISK	INTENT	INVEST
PERISK	0.925		
INTENT	0.197	0.890	
INVEST	0.160	0.390	0.739

AVE: Average variance extracted

Table 7: Standardized residual covariance

	RETU2	RETU1	RETU3	RISK3	RISK1	RISK2	INTE6	INTE5	INTE1	INTE2	INTE4	INTE3
RETU2	0											
RETU1	0.158	0										
RETU3	-0.07	-0.04	0									
RISK3	-0	-0.41	0.766	0								
RISK1	0.217	-0.69	0.593	-0.01	0							
RISK2	-0.55	-0.75	0.507	0	0.006	0						
INTE6	0.387	0.351	0.871	0.846	0.259	0.46	0					
INTE5	-0.02	0.148	0.195	0.061	-0.32	-0.56	0.226	0				
INTE1	-0.48	-0.11	0.411	0.647	0.253	-0.31	-0.57	-0.23	0			
INTE2	0.042	0.112	0.056	0.708	0.39	0	-0.06	-0.2	0.599	0		
INTE4	0.304	-1.02	0.508	1.231	0.29	0.636	0.417	0.297	-0.16	-0.41	0	
INTE3	-0.84	-0.35	-0.42	-0.2	-1.04	-1.09	-0.07	-0.05	0.133	0.051	-0.02	0

The finding indicated INVEST had a positive impact on INTENT as the third model proposed. The following equation might be depicted as follows:

$$INTENT_i = 0.37INVEST_i^{***} \quad (3')$$

More interestingly, INVEST had the strong impact on INTENT with the standardized coefficient for INVEST at 0.37 (**P < 0.001). The equation (3') can be interpreted as follows: if INVEST increases/decreases by 1 standard deviation, INTENT will go up/down by 0.37 standard deviations. More specifically, an increase of 1% of satisfaction level of investment decisions or of the recent rate of return achieved will lead to an increase of 37% in intentions to invest in stocks. Apparently, investment performance and intentions have a strong relationship (37%). This exploration is similar to research of Gopi and Ramayah (2007), Alleyne and Broome (2011), and East (1993).

Finally, the results also supported the fourth model related to the indirect effects of perceived risk (PERISK) on intentions to invest (INTENT) through investment performance (INVEST). More impressively, PERISK had direct and indirect impact on INTENT. Standardized coefficient total effects were shown in Table 9.

Figure 2: Path significant coefficient of the research model

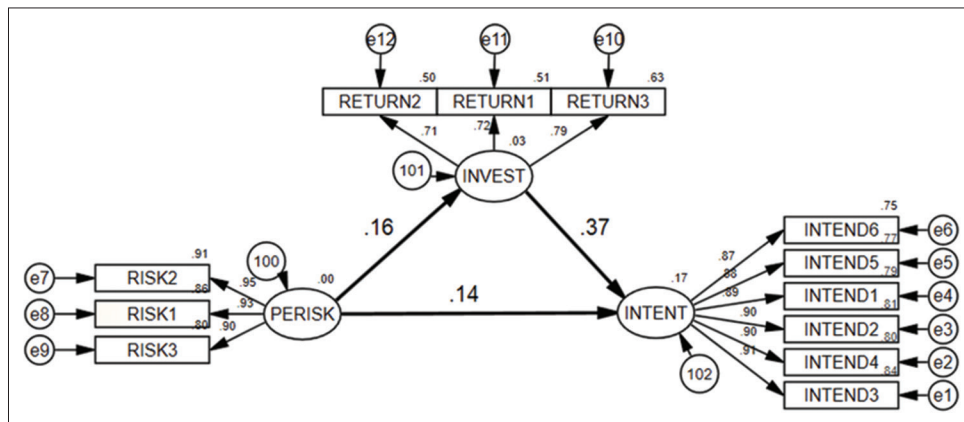

As shown in Table 9, total effects of PERISK on INTENT was 0.1992. This number mathematically means that when PERISK and INVEST simultaneously goes up/down by 1 standard deviation, INTENT increases/decreases by 0.5692 standard deviations. The equation (4') might be proposed as follows:

$$INTENT_i = 0.1992PERISK_i + 0.37 INVEST_i \quad (4')$$

5. CONCLUDING REMARK

The study primarily met requirements of the reliability and validity tests and generalization to the entire individual investors trading on the Vietnam stock market. Additionally, the study built the new measurement scales of perceived risk, and then using these measurement scales to explore the effect of perceived risk on investment performance, and on investment intentions. Especially, perceived risk had direct and indirect impact on intentions to invest. Generally, most of the investors had high risk perception in investing stock types, in which the higher investors perceive risks in investing, the greater they gratify their investment decisions or the more they intend to invest in stocks.

Importantly, the study answered three research questions. Firstly, the new measurement scales (5 items) of perceived risk. Secondly, the level of impact of perceived risk on investment performance by 0.16, and intentions by 0.14; thirdly, the indirect effect of perceived risk on intentions through investment performance by 0.1992.

In addition, investors need to understand what cases stocks are placed under alert, halted trading or controlled. Normally, stocks violate the securities listing regulations at HOSE with Decision No. 10/QĐ-SGDHCM dated 10/01/2014 such as a decrease of charter capital under VND 120 billion, negative profit after tax or accumulated losses, stopped business or stopped main activities from more than 3 months, often violating regulations of information announcement, and the stock not trading within 6 or 9 months for being controlled. According to experts, investing high risky stocks was still better than playing games or buying lucky lottery tickets that their results were completely based on destiny. However, before investing, investors should divide up their total income into smaller parts, for instance, short-term, long-term investments, savings, daily expenses, and high risk investment.

Table 8: MIs of the variables

Variables	MI
INTEND4←RETURN1	4.651
INTEND4←RISK2	4.239
INTEND3←PERISK	6.721
INTEND3←RISK1	7.419
INTEND3←RISK2	6.449

MI: Modification indices

Table 9: Standardized coefficient total effects of INTENT

Variables	INTENT		
	Direct	Indirect	Total
PERISK	0.14	0.0592	0.1992
INVEST	0.37	-	0.37
Total	0.51	0.0592	0.5692

More significantly, investors strictly pursue this allocation in order to avoid bankrupt if they face with failure.

Furthermore, securities corporations should organize seminars, conferences, meetings or training courses in which investors have a number of opportunities to discuss as well as learn precious lessons. Particularly, updating regulations of stock investment and supporting investors for using financial leverage are one of the important missions of securities corporations. However, some of them have not enough capital for this support, which caused difficulties for investors. The State Securities Commission of Vietnam, therefore, needs to control and mitigate a quantity of securities corporations and listed companies because of an increase of capacity as well as the services quality.

Finally, the limitation of the study is to focus on the relationship among perceived risk, investment performance, and investment intentions of individual investors. In fact, many behavioral bias might affect investment intentions such as representativeness bias, overconfidence, anchoring bias, gambler’s fallacy, availability bias, herding, over-under reaction, mental accounting, self-control, regret aversion, etc. Among heuristics, gambler’s fallacy has been proposed to require further research since most of the Vietnamese investors are young and less than 5 years of experience in stock investment. They still believe that if stocks have traded many times for this period, these stocks will be less traded next periods or if a stock’s price has fallen in multiple sessions, the price will be impossible to decline more. In addition, how perceived uncertainty of an investor is before making a decision: whether or not one is afraid of making a mistake. This, perception should also be taken notice since it might affect investment intention and performance.

REFERENCES

Ajzen, I. (1991), The theory of planned behavior. *Organizational Behavior and Human Decision Processes*, 50(2), 179-211.

Ajzen, I., Fishbein, M. (1980), Theory of reasoned action/Theory of planned behavior. *Social Psychology*, 2007, 67-98. Available from: http://www.hsc.usf.edu/~kmbrown/TRA_TPB.htm.

Alleyne, P., Broome, T. (2011), Using the theory of planned behaviour and risk propensity to measure investment intentions among future investors. *Journal of Eastern Caribbean Studies*, 36(1), 1-20.

Baker, H.K., Nofsinger, J.R., editors. (2010), *Behavioral Finance: Investors, Corporations, and Markets*. Vol. 6. New York: John Wiley & Sons.

Barberis, N., Huang, M. (2001), Mental accounting, loss aversion, and individual stock returns. *The Journal of Finance*, 56(4), 1247-1292.

Bauer, R.A. (1960), *Consumer Behavior as Risk-Taking*, Dynamic Marketing for Changing World. Chicago: American Marketing Association.

Belch, G.E., Belch, M.A. (2003), *Advertising and Promotion: An Integrated Marketing Communications Perspective*. Boston: The McGraw-Hill.

Bhatnagar, A., Misra, S., Rao, H.R. (2000), On risk, convenience, and Internet shopping behavior. *Communications of the ACM*, 43(11), 98-105.

Chang, M.K., Cheung, W., Lai, V.S. (2005), Literature derived reference models for the adoption of online shopping. *Information and Management*, 42(4), 543-559.

Cuong, P.K., Jian, Z. (2014), Factors influencing individual investors

- behavior: An empirical study of the Vietnamese stock market. *American Journal of Business and Management*, 3(2), 77-94.
- Dai, B., Forsythe, S., Kwon, W.S. (2014), The impact of online shopping experience on risk perceptions and online purchase intentions: Does product category matter? *Journal of Electronic Commerce Research*, 15(1), 13-24.
- Dodds, W.B., Monroe, K.B., Grewal, D. (1991), Effects of price, brand, and store information on buyers product evaluations. *Journal of Marketing Research*, 28(3), 307-319.
- Dowling, G.R., Staelin, R. (1994), A model of perceived risk and intended risk-handling activity. *Journal of Consumer Research*, 21, 119-134.
- East, R. (1993), Investment decisions and the theory of planned behaviour. *Journal of Economic Psychology*, 14(2), 337-375.
- Forsythe, S., Liu, C., Shannon, D., Gardner, L.C. (2006), Development of a scale to measure the perceived benefits and risks of online shopping. *Journal of Interactive Marketing*, 20(2), 55-75.
- Forsythe, S.M., Shi, B. (2003), Consumer patronage and risk perceptions in Internet shopping. *Journal of Business Research*, 56(11), 867-875.
- Foxall, G. (1990), *Consumer Psychology in Behavioral Perspective*. Frederick, MD: Beard Books.
- Francis, J.J., Johnston, M., Robertson, C., Glidewell, L., Entwistle, V., Eccles, M.P., Grimshaw, J.M. (2010), What is an adequate sample size? Operationalising data saturation for theory-based interview studies. *Psychology and Health*, 25(10), 1229-1245.
- Galvin, R. (2015), How many interviews are enough? Do qualitative interviews in building energy consumption research produce reliable knowledge? *Journal of Building Engineering*, 1, 2-12.
- Gervais, S., Heaton, J.B., Odean, T. (2002), The positive role of overconfidence and optimism in investment policy. Rodney L. White Center for Financial Research-Working Papers.
- Gopi, M., Ramayah, T. (2007), Applicability of theory of planned behavior in predicting intention to trade online: Some evidence from a developing country. *International Journal of Emerging Markets*, 2(4), 348-360.
- Hair, J.F., Black, W.C., Babin, B.J., Anderson, R.E. (2014), *Multivariate Data Analysis*. Vol. 7. UK: Pearson Education Limited.
- Howard, J.A., Sheth, J.N. (1969), *The Theory of Buyer Behavior*. Vol. 14. New York: Wiley.
- Johnsson, M., Lindblom, H., Platan, P. (2002), Behavioral Finance-and the Change of Investor Behavior During and after the Speculative Bubble at the End of the 1990s.
- Kahneman, D., Tversky, A. (1979), Prospect theory: An analysis of decision-making under risk. *Econometrica*, 47(2), 263-291.
- Kassim, N.M., Ramayah, T. (2015), Perceived risk factors influence on intention to continue using Internet banking among Malaysians. *Global Business Review*, 16(3), 393-414.
- Kim, K.A., Nofsinger, J.R. (2003), The behavior and performance of individual investors in Japan. *Pacific Basin Finance Journal*, 11(1), 1-22.
- Krejcie, R.V., Morgan, D.W. (1970), Table for determining sample size from a given population. *Educational and Psychological Measurement*, 30, 607-610.
- Lin, A.Y., Swanson, P.E. (2003), The behavior and performance of foreign investors in emerging equity markets: Evidence from Taiwan. *International Review of Finance*, 4(3-4), 189-210.
- Mayfield, C., Perdue, G., Wooten, K. (2008), Investment management and personality type. *Financial Services Review*, 17(3), 219-228.
- Mitchell, V.W. (1999), Consumer perceived risk: Conceptualisations and models. *European Journal of Marketing*, 33(1/2), 163-195.
- Miyazaki, A.D., Fernandez, A. (2001), Consumer perceptions of privacy and security risks for online shopping. *Journal of Consumer Affairs*, 35(1), 27-44.
- Noort, G.V., Kerkhof, P., Fennis, B.M. (2008), The persuasiveness of online safety cues: The impact of prevention focus compatibility of Web content on consumers risk perceptions, attitudes, and intentions. *Journal of Interactive Marketing*, 22(4), 58-72.
- Oberlechner, T., Osler, C.L. (2008), Overconfidence in currency markets. Available from: <http://www.ssrn.1108787>.
- Schwager, J.D. (1993), *Market Wizards: Interviews with Top Traders*. New York: Collins.
- Shadfar, S., Malekmohammadi, I. (2013), Application of structural equation modeling (SEM) in restructuring state intervention strategies toward paddy production development. *International Journal of Academic Research in Business and Social Sciences*, 3(12), 576-618.
- Soderlund, M., Ohman, N. (2003), Behavioral intentions in satisfaction research revisited. *Journal of Consumer Satisfaction, Dissatisfaction and Complaining Behavior*, 16, 53-66.
- Warkentin, M., Gefen, D., Pavlou, P.A., Rose, G.M. (2002), Encouraging citizen adoption of e-government by building trust. *Electronic Markets*, 12(3), 157-162.

APPENDIX

Appendix Table

GFI	The research model	Standard (Hair et al., 2014. p. 584)
Chi-square (χ^2)		
Chi-square	99.566 (P = 0.000)	# 0, Significant P values expected
Degree of freedom	51	
Absolute fit measures		
GFI	0.965	Above 0.90
RMSEA	0.045	Values < 0.07 with CFI of 0.90 or higher
90% confidence interval of RMSEA	0.032-0.058	
RMR	0.019	
SRMR	0.0212	0.08 or less (with CFI above 0.92)
Normal Chi-square	1.952	<5
Incremental fit indices		
NFI	0.979	Above 0.90
NNFI or the TLI	0.987	Above 0.90
CFI	0.99	Above 0.90
RFI	0.973	Above 0.90
Parsimony fit indices		
AGFI	0.946	Above 0.90
PNFI	0.757	Above 0.747 (Shadfar and Malekmohammadi, 2013. p. 587)

GFI: Goodness-of-fit index, RMSEA: Root mean square error of approximate, RMR: Root mean square residual, SRMR: Standardized root mean residual, NFI: Normed fit index, NNFI: Non-normed fit index, TLI: Tucker-Lewis index, CFI: Comparative fit index, RFI: Relative fit index, AGFI: Adjusted goodness-of-fit index, PNFI: Parsimony normed fit index