

# **Performance Comparison of Semi-Active Suspension and Active Suspension System Using MATLAB/ Simulink**

R N Yerrawar<sup>1</sup>, Dr.R.R.Arakerimath<sup>2</sup>, Patil Sagar Rajendra<sup>3</sup>, Walunj Prashant Sambhaji<sup>4</sup>

Assistant Professor, Dept. of Mechanical Engineering, MES College of Engineering Pune, India<sup>1</sup>

Professor, G H Raisoni COE and Management, Wagholi, Pune, India<sup>2</sup>

.P.G. Student, Dept. of Mechanical Engineering, MES College of Engineering Pune, India<sup>3</sup>

P.G. Student, Dept. of Mechanical Engineering, MES College of Engineering Pune, India<sup>4</sup>

**ABSTRACT:** In this paper a brief introduction to MR damper and its various types with a brief introduction to vehicle primary suspension system is presented along with analysis of a semiactive suspension system. Isolation from the forces transmitted by external excitation is the fundamental task of any suspension system. The heart of a semi active suspension system is the controllable damper. In this paper, the ride and handling performance of a specific vehicle with passive suspension system is compared to semiactive suspension system. The body suspension wheel system is modeled as a two degree of freedom quarter car model.

Simulation is carried out using MATLAB/Simulink. The developed design allows the suspension system to behave differently in different operating conditions, without compromising on road-holding ability. Controller has been developed for semi active suspension. The result shows improvement over passive suspension method.

**KEYWORDS:** MR Damper, Active suspension system, Semi Active suspension system.

## **I. INTRODUCTION**

A damper (shock absorber) is a mechanical device designed to smooth out or damp shock impulse, and dissipate kinetic energy. MR damper technology was originally developed by General Motors for use in the Cadillac and Chevrolet Corvette in 1998<sup>[1]</sup>. In recent years, a flurry of interest has been shown for a relatively old technology called magneto-rheological fluids, or MR fluids. Multiple types of devices have been designed to implement this versatile fluid, including linear dampers, clutches, work-piece fixtures, and polishing machines. The devices have been used in automobiles, washing machines, bicycles, prosthetic limbs, and even smart structures. The MR dampers provided a more stable ride than that of the OEM dampers. By reducing suspension displacement, settling time, and suspension oscillations, the MR dampers were able to reduce suspension geometry instability<sup>[2]</sup>. A MR damper consists of a hydraulic cylinder containing MR fluid that, in the presence of a magnetic field, can reversibly

change from a free-flowing, linear viscous fluid to a semisolid with controllable yield strength in fraction of a second. Magneto-rheological damper (MR damper) has been expected to control the response of civil and building structures in recent years, because of its large force capacity and controllable force characteristics.

### **II Task of automotive suspension system on vehicle:**

- 1) To isolate a car body from road disturbances
- 2) To keep road holding
- 3) To support the vehicle static weight

Primary suspension is the term used to designate those suspension components connecting the axle and wheel assemblies of a vehicle to the frame of the vehicle. This is in contrast to the suspension components connecting the

# International Journal of Innovative Research in Science, Engineering and Technology

(An ISO 3297: 2007 Certified Organization)

Vol. 3, Issue 12, December 2014

frame and body of the vehicle, or those components located directly at the vehicle's seat, commonly called the secondary suspension<sup>[4]</sup>. There are two basic types of elements in conventional suspension systems. These elements are springs and dampers. The role of the spring in a vehicle's suspension system is to support the static weight of the vehicle. The role of the damper is to dissipate vibrational energy and control the input from the road that is transmitted to the vehicle. The basic function and form of a suspension is the same regardless of the type of vehicle or suspension<sup>[5]</sup>. Vehicle Primary Suspensions is divided into passive, active and semi-active systems. In Semiactive suspension system, the conventional.

In Semiactive suspension system, the conventional spring element is retained, but the damper is replaced with a controllable damper. Magnetorheological (MR) damper is a kind of semiactive device. A wide range of Magneto-rheological (MR) fluid based dampers are currently being explored for their potential implementation in various systems, such as vibration control devices and suspension system. The main function of vehicle suspension systems are to minimize the vertical acceleration transmitted to passengers to provide ride comfort and to maintain the tire road contact to provide holding characteristics, and to keep suspension travel small. In this paper, performance of semiactive suspension model (2DOF) based on the Bingham model subjected to random road excitation is compared with passive suspension system. This semiactive vehicle suspension shows improvement over passive vehicle suspension.

### I.II MAGNETORHEOLOGICAL FLUID:

A magneto rheological fluid (MR fluid) is a type of smart fluid in a carrier fluid, usually a type of oil. When subjected to a magnetic field, the fluid greatly increases its apparent viscosity, to the point of becoming a viscoelastic solid. Importantly, the yield stress of the fluid when in its active ("on") state can be controlled very accurately by varying the magnetic field intensity. The upshot of this is that the fluid's ability to transmit force can be controlled with an electromagnet, which gives rise to its many possible control-based applications as shown in Figure 1.

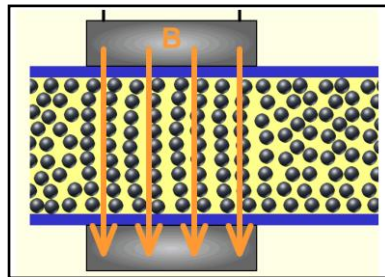

**Figure1:** Schematic of a magneto rheological fluid

### I.III WORKING OF MR FLUID:

With no applied magnetic field (off state), MR fluids behave with Newtonian-like characteristics. Applying an external magnetic field through the fluid activates MR fluids, causing the micron-sized particles to form magnetic dipoles along the lines of magnetic flux, as shown in Figure 2.

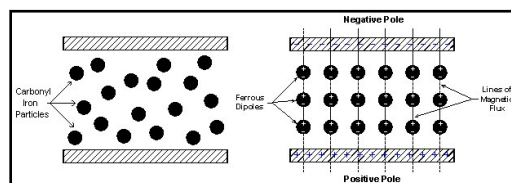

**Figure 2 :** Off-state MR Fluid particles (left). Aligning in an

# International Journal of Innovative Research in Science, Engineering and Technology

(An ISO 3297: 2007 Certified Organization)

Vol. 3, Issue 12, December 2014

The dipoles align parallel to the induced magnetic flux lines to form chain-like Structures of iron particles between the north and south pole. The ferrous particles that form each of the chains resist movement out of their respective flux lines, and the amount of resistance is proportional to the intensity of the applied magnetic field. The reluctance of the ferrous dipole chains to move result in a restriction of the fluid flow.

## II. BINGHAM MODEL

The idealization of the visco-plastic MR damper model presented in uses similarities in the rheological behavior of ER and MR fluids and the similar techniques in the modeling of ER dampers In the rheological structure in Figure 6, on which the Bingham model is based, there is a Coulomb friction element  $f_c$  placed parallel to the dashpot  $c_0$ . [7]

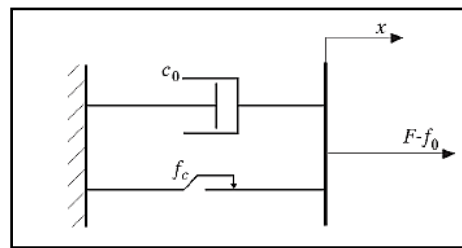

**Figure 3:** Schematic of Bingham model

According to Bingham’s MR damper model, for non-zero piston velocities  $\dot{x}$ , the damping force  $f_a$  can be expressed as

$$f_a = f_c \operatorname{sgn} \dot{x} + c_o \dot{x} + f_o$$

Where  $f_c$  is the frictional force,  $C_0$  is the viscous damping parameter;  $f_0$  is the force due to the presence of the accumulator. This last simplification in the model results from the assumption that the elasticity replacing the accumulator activity has a low stiffness and linear characteristics.

## III. MODELLING OF SYSTEM

### III.I Quarter Car Model with Semi active Suspension System:

The proposed system is 2DOF quarter car vehicle with a MR damper. The dynamics of the damper are modeled with the Bingham model i.e. first model used to describe the behavior of MR damper. The Bingham model contains the nonlinear behavior of a viscous fluid going through an orifice.

### III.II Notations

$m_s$  represents one quarter of sprung mass;  $m_u$  represents unsprung mass (wheel, damper and spring etc.);  $x_s$  and  $x_t$  are the masses displacement and  $q$  represents the road disturbances,  $k_t$  is the tire stiffness;  $k_s$  is the spring between wheel and chassis [3].

# International Journal of Innovative Research in Science, Engineering and Technology

(An ISO 3297: 2007 Certified Organization)

Vol. 3, Issue 12, December 2014

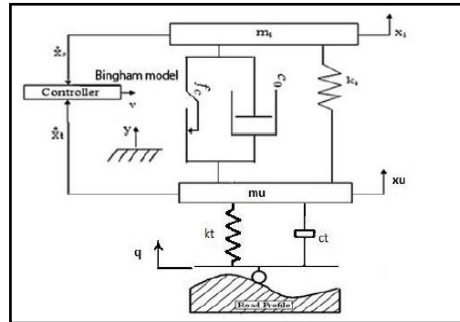

Figure 4: Quarter car vehicle with MR damper

For the controller,  $(\dot{x}_s)$  and  $(\dot{x}_t)$  represents absolute velocity of sprung mass and unsprung mass respectively. Controller generates the voltage  $v$  in the MR damper and it modifies the force  $f_a$  of semi active suspension. The motion equations of the car body and wheel of this model are as follows,

$$m_s \ddot{x}_s = -[k_s(x_s - x_u) + f_a]$$

$$m_u \ddot{x}_u = -\{ -[k_s(x_s - x_u) + f_a] + [k_t(x_u - q) + c_t(\dot{x}_u - \dot{q})] \}$$

## IV. ACTIVE SUSPENSION SYSTEM

To provide the vehicle with improved ride quality, handling and performance under various operating conditions, the concept of an active suspension emerged. The spring and shock absorber in conventional system are replaced by a forced actuator in an active system. The actuator may also be installed in parallel with a conventional suspension spring. Operating conditions are continuously monitored by sensors. Based on the signals obtained by sensors and prescribed control strategy, force in the actuator is modulated to achieve improved ride, handling and performance. Generally speaking, optimum control strategy is defined as the one that minimizes the following:

- 1) RMS value of the sprung mass acceleration.
- 2) RMS value of suspension travel.
- 3) RMS value of dynamic tire deflection.

Usually these quantities are multiplied by weighing factors, and then combined to form an evaluation function. Various control theories have been applied to establishing the optimum control strategy to minimize the evaluation function. The active suspension can also be used to control the height, roll, dive and squat of vehicle body. By exercising height control, ride height of vehicle body can be kept constant despite change in load. This ensures adequate suspension travel for negotiating bumps. It should be noted, however, that an active suspension system requires significant external power to function, and that there is also a considerable penalty in complexity, reliability, cost and weight. There is a four different type for car suspensions. In our model we modeled and analyzed only one suspension type. The following figure shows an active suspension of automobiles. Active suspension systems are different from the traditional passive suspensions especially with energizing, damping characteristics and retention features.

# International Journal of Innovative Research in Science, Engineering and Technology

(An ISO 3297: 2007 Certified Organization)

Vol. 3, Issue 12, December 2014

## V. SIMULINK MODELS OF ACTIVE AND SEMI ACTIVE SUSPENSION SYSTEM

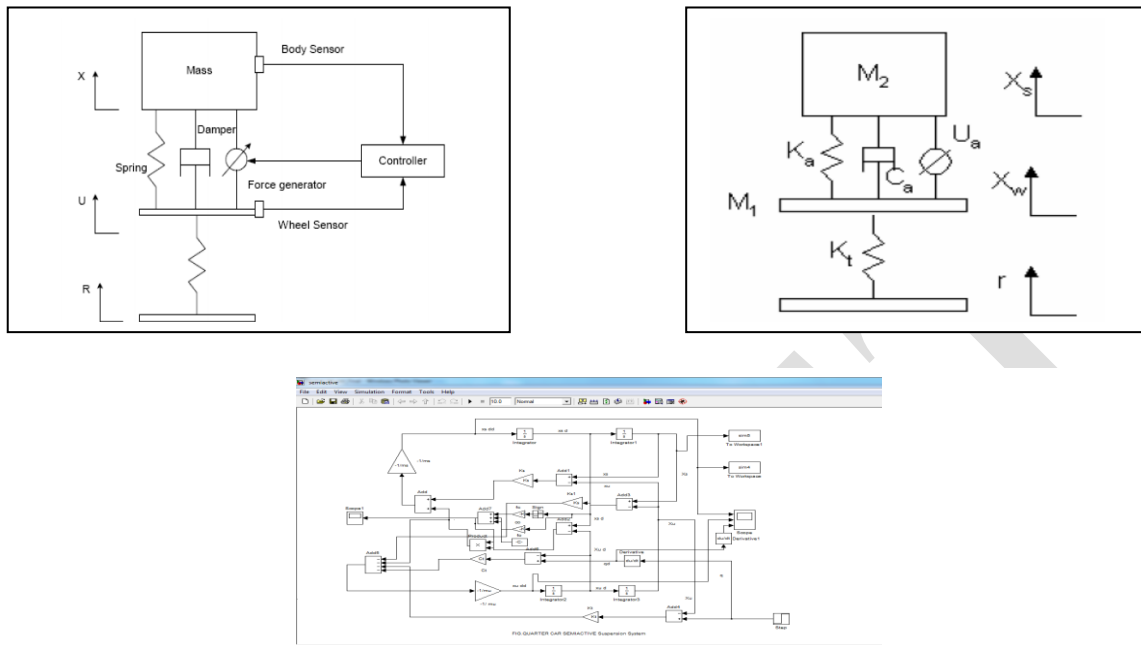

**Figure 5 :** MATLAB/Simulink Model of Semiactive Suspension System based on Bingham Model

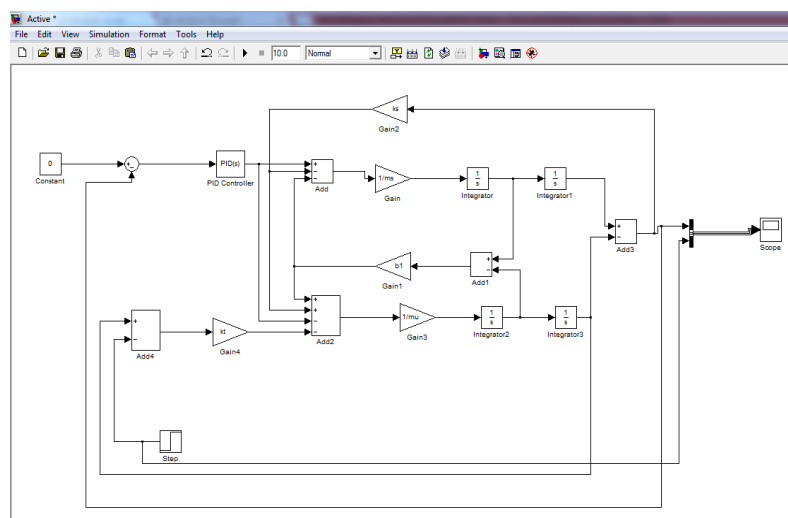

**Figure 6 :** MATLAB/Simulink Model of active Suspension System based on Bingham Model

Semi-active Suspension	Parameter	Active Suspension
400	Ms or M2	400
40	Mu or M1	40

**International Journal of Innovative Research in Science,  
Engineering and Technology**

*(An ISO 3297: 2007 Certified Organization)*

**Vol. 3, Issue 12, December 2014**

22500	Ka	22500
2500	Ca	2500
175000	Kt	175000
230	Ct	230

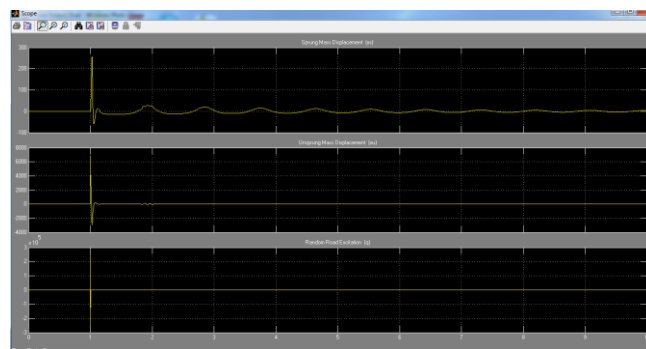

**Figure 7 :** For Semi Active suspension system.

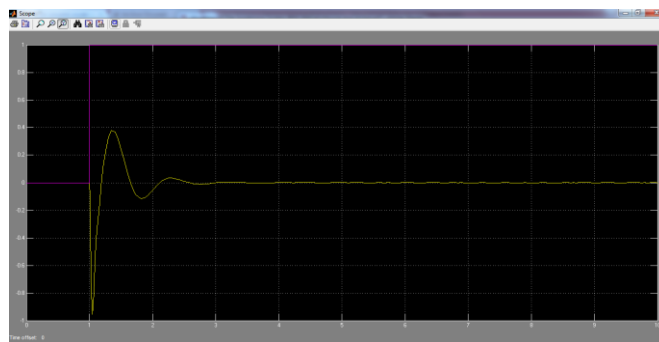

**Figure 8 :** For Active suspension system :

The percentage variation in maximum sprung mass acceleration of semiactive suspension system based on Bingham model is 20.52% from passive suspension system. So it shows that semiactive suspension system gives lower value of maximum sprung mass acceleration for given random road excitation.

**VIII. CONCLUSION**

The semi active suspension system and active suspension system with MR damper (Bingham Model) is simulated. The simulation results shows that active suspension system with Bingham model gives lower value of maximum sprung mass acceleration for given random road excitation. Hence suspension model with active suspension provides good passenger comfort and vehicle stability than semi active suspension system.

# International Journal of Innovative Research in Science, Engineering and Technology

(An ISO 3297: 2007 Certified Organization)

Vol. 3, Issue 12, December 2014

## REFERENCES

1. Yi, K. and Hedrick, K., "Dynamic Tire Force Control by Semi active Suspensions", Journal of Dynamic Systems, Measurements, and Control, Vol. 115, No. 3, pp. 465-474, September 1993.
2. Sapiński B., Filus J. 2003, "Analysis of parametric models of MR linear damper", Journal of Theoretical and Applied Mechanics, 41, 215-240.
3. Luis C. Felix-Herran, Jose de Jesus Rodrigues-Ortiz, Rogelio Soto, Ricardo Ramirez-Mendoza, "Modeling and control for a semi active suspension with a Magnetorheological Damper including the actuator dynamics", Electronics, Robotics and Automotive Mechanics Conference 2008, pp 338-343.
4. H.F.Lam, W H Liao and C Y Lai, "Automobile Suspension Systems with MR fluid Dampers", Smart Materials and Structures, 11 (2002)
5. R.N. Yerrawar, V. Tungikar and S. Gawande, "Finite Element Analysis of Dynamic Damper for CV Joint", Energy and Power Engineering, Vol. 4, 2012, P.P.241-247
6. Prof. Sanjay H. Sawant, Dr. J. A. Tamboli, "Comparative study of passive and semi-active suspension system subjected to random excitation", International Journal on Mechanical and Automobile Engineering, ISSN 0974-231, (2011).
7. Nitin Ambhore, Shyamsundar Hivarale, Dr. D. R. Pangavhane "A Study of Bouc-Wen Model of Magnetorheological Fluid Damper for Vibration Control"