

N O T I C E

THIS DOCUMENT HAS BEEN REPRODUCED FROM
MICROFICHE. ALTHOUGH IT IS RECOGNIZED THAT
CERTAIN PORTIONS ARE ILLEGIBLE, IT IS BEING RELEASED
IN THE INTEREST OF MAKING AVAILABLE AS MUCH
INFORMATION AS POSSIBLE

NASA Technical Memorandum 81552 (Revised)

(NASA-TM-81552-Rev) PERFORMANCE
DETERIORATION OF COMMERCIAL HIGH-BYPASS
RATIO TURBOFAN ENGINES (NASA) 30 p
HC A03/MF A01

N80-32394

CSSL 21E

Unclas

83/07

28728

**PERFORMANCE DETERIORATION OF
COMMERCIAL HIGH-BYPASS RATIO
TURBOFAN ENGINES**

Charles M. Mehalic and Joseph A. Ziemianski
Lewis Research Center
Cleveland, Ohio

Prepared for the
SAE Aerospace Congress, Los Angeles, California,
October 13-16, 1980

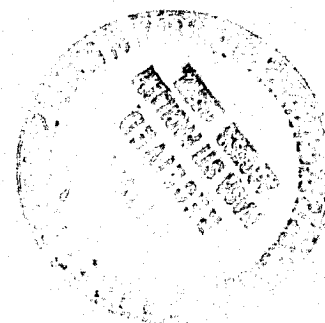

NASA

Performance Deterioration of Commercial

High-Bypass Ratio Turbofan Engines*

by

Charles M. Mehalic and Joseph A. Ziemianski

National Aeronautics and Space Administration

Lewis Research Center

Cleveland, Ohio

SUMMARY

The Aircraft Energy Efficiency Program within NASA is developing technology required to improve the fuel efficiency of commercial subsonic transport aircraft. One segment of this program, the Engine Component Improvement (ECI) Project, includes Engine Diagnostics which is directed toward determining the sources and causes of performance deterioration in the Pratt & Whitney Aircraft JT9D and General Electric CF6 high-bypass ratio turbofan engines and developing technology for minimizing the performance losses. This paper presents the results of engine performance deterioration investigations based on historical data, special engine tests, and specific tests to define the influence of flight loads and component clearances on performance. The results of analyses of several damage mechanisms that contribute to performance deterioration such as blade tip rubs, airfoil surface roughness and erosion, and thermal distortion are also included. The significance of these damage mechanisms on component and overall engine performance is discussed.

*Also presented at the Fifty-Sixth AGARD Propulsion and Energetics Symposium on Turbine Engine Testing, Turin, Italy, Sept. 29 - Oct. 3, 1980, as "Investigation of Performance Deterioration of the CF6/JT9D High-Bypass Ratio Turbofan Engines" by Joseph A. Ziemianski and Charles M. Mehalic.

IN RESPONSE TO THE NEED for more fuel efficient aircraft and the problems of fuel availability and cost, the National Aeronautics and Space Administration (NASA) started the Aircraft Energy Efficiency (ACEE) program in 1975. Efficient air transportation is an international concern because commercial aircraft constitute a primary segment of public transportation and have significant influence on world commerce. Rapid escalation of fuel prices as shown in Figure 1, taken from U.S. Civil Aeronautics Board (CAB) data (1)*, is threatening the viability of air transportation. The dramatic fuel price increases in late 1973 and in 1979 have caused airline direct operating costs (DOC) to increase and fuel costs, at current levels, account for almost 60 percent of the DOC (2).

An element of the ACEE program, the Engine Component Improvement (ECI) project, managed by the Lewis Research Center, includes Engine Diagnostics in which engine performance deterioration studies were conducted by Pratt and Whitney Aircraft for the JT9D engine and the General Electric Company for the CF6 engine. The basic objectives of Engine Diagnostics were to 1) determine the specific causes of engine performance deterioration that increase fuel consumption and 2) isolate and identify the mechanisms associated with engine performance deterioration.

The general approach to investigating the mechanisms that contribute to engine performance deterioration was:

1. Gather historical (existing) data from engine tests at both airline and engine overhaul shops and from airline in-flight recordings and conduct inspections of used parts.
2. Supplement this information with special engine tests and inspections to evaluate the effects of deteriorated components and subsequent refurbishment on module and overall engine performance.
3. Establish statistical trends and analytical models of engine performance deterioration
4. Isolate engine performance deterioration to specific events and/or modules and conduct specific effects testing to quantify in more detail the mechanism and magnitude of engine performance deterioration.

Mehalic
Ziemianski

*Numbers in parentheses designate References at end of paper.

The results of these investigations are not complete but are sufficient to indicate the sources and causes of performance deterioration in the JT9D and CF6 high-bypass ratio turbofan engines.

ENGINE DESCRIPTION

The Pratt & Whitney JT9D-3A/7/20 and General Electric CF6-6D engines (Figs. 2 and 3) are used to power the Boeing 747 and Douglas DC-10 airplanes. Both engines are assembled and maintained via a modularized concept. Typical module nomenclature for the CF6 engine is shown in Figure 4. The JT9D nomenclature is similar, except the quarter stage is replaced by a low pressure compressor module. Table 1 describes some of the characteristics of each engine.

It should be noted that the JT9D and CF6 engines are maintained using an "on-condition maintenance" concept. Under this concept the engines are repaired as required based on engine inspection data rather than at a fixed time interval. This "on-condition maintenance" concept requires the engines be constructed of modules or subassemblies that are easily disassembled and completely interchangeable. This permits maintenance of individual modules rather than entire engines, and moreover, permits repair of only those parts that are defective. Thus, in airline practice, when an engine enters the shop for repairs, typically the modules are separated, repaired if required, and dispersed to inventory. A "new" engine is then assembled from modules from inventory and returned to the fleet for service.

RESULTS AND DISCUSSIONS

HISTORICAL DATA - Performance deterioration trends were determined by both Pratt and Whitney (JT9D) and General Electric (CF6) from analyses of historical information from contributing airlines (representing approximately one-third of the free world's fleet of airplanes), aircraft companies, overhaul/repair organizations, and engine manufacturers. Figure 5 shows the sources of these data. Included were 1) data from engine testing (e.g., production acceptance, aircraft acceptance, and pre- and post-repair), 2) normal flight data, and 3) observations and documented records of used parts condition and replacement rates.

Mehalic
Ziemianski

The major contributors to performance deterioration are shown in Figures 6 and 7. In the cold section of the engine (fan and compressor), airfoil quality (foreign object damage (FOD), erosion, and surface roughness) is significant. In the hot section of the engine, thermal distortion is one of the predominant deterioration mechanisms causing, for example, warpage or distortion of vanes. Clearance increases resulting in efficiency losses occur throughout the entire engine as a result of blades rubbing their outer shrouds.

The performance deterioration mechanisms - such as clearance increases, erosion and airfoil roughness, and thermal distortion - affect the cruise specific fuel consumption (SFC) as shown in Figure 8, for the JT9D-3A/7/20 engine modules (3), (4), (5) and Figure 9 for the CF6-6D engine modules (6). In each of these figures, the deterioration mechanisms reflect the module condition at three points in an engine's life cycle:

1. After the first flight of an airplane
2. Multiple flights - typical of the engine's condition prior to its first repair
3. Multiple flights after first repair/overhaul

The assumptions used to construct Figures 8 and 9 were 1) the original modules remained together and were not separated, and 2) only the high pressure turbine module was replaced or repaired between the second and third point in the engine life cycle. These assumptions were employed to illustrate each module's contribution to engine performance deterioration over a number of flights. Summing the modular deterioration at a selected number of flights then gives the deterioration for an "average" engine. The combustion system is omitted in Figures 8 and 9 because the direct effect of combustor deterioration on performance is insignificant. It should be acknowledged, however, that the indirect effects on performance can be significant. In addition to reducing turbine life, changes in radial and circumferential temperature patterns affect clearances and cause other mechanical changes in the turbine. The NASA Engine Diagnostics program did not address these indirect effects.

Figures 8 and 9 represent an average value of performance deterioration based on available samples of historical data. In some instances the data sample was limited (e.g., pre-repair test results) and the data scatter was large. To quantify the variability of the historical data, statistical methods were employed by

Mehalic
Ziemianski

both Pratt and Whitney and General Electric. Table 2 shows the average values of performance deterioration along with the statistical deviations.

An examination of the historical data reveals, for both engines, an early deterioration (referred to as short-term deterioration) occurs within the first few flights of an airplane. For the studies, it was decided to use the first flight of the airplane as the base for quantifying short-term effects. The subsequent deterioration, referred to as long-term deterioration, is more gradual and increases with flight cycles and/or time until the engine is removed from the airplane because of mechanical problems or exceedance of established exhaust gas temperature (EGT) limits.

The values for the short-term deterioration for the JT9D and CF6 engines were determined from both test cell and cruise performance recordings supplemented by hardware inspections. The assessments from these data sources indicated the average short-term performance deterioration of the JT9D-3A/7/20 is a 0.7 percent cruise SFC increase while the CF6 value is 0.8 to 0.9 percent. The 0.8 percent SFC value for the CF6-6D is based upon hardware observations and documented records of used parts condition while performance data results, which substantiated the hardware results within the range of data scatter, indicated the value to be slightly higher (0.9 percent). For this paper the hardware/used part value is used. Hardware/used part examinations showed that clearance increases are the predominant cause of short-term deterioration during the first flight (Figs. 8 and 9) and are a result of rubs of stationary and rotating parts. These rubs in the JT9D are believed to be associated with deflections produced by aircraft induced flight loads that occur during take off rotation, flight maneuvers, landing, and thrust reversal. Engine power transients during these flight events may also contribute to rotor/case interferences that produce increases in blade tip clearances.

Examination of the CF6-6D data (Fig. 9) shows that high pressure turbine clearance increases contribute over 90 percent of the total short-term performance deterioration. The cause of this performance deterioration is believed associated with an event which produces rotor/case interferences that result

Mehalic
Ziemianski

in increased blade tip clearances. This event is termed "hot rotor reburst" (Fig. 10) and is a type of thermal transient response which can result in high pressure turbine blade rubs due to different thermal growth rates between rotating and stationary structures. This event, while not a normal operation, may occur during aircraft acceptance tests or avoidance maneuvers.

Long-term performance deterioration data included test cell recordings (pre-repair), cruise performance recordings and hardware inspection records. The assessments from these data sources indicated the average performance deterioration for the JT9D-3A/7/20 at 1000 flights was 2.0 percent in cruise SFC and this value grew to 3.0 percent at 3000 flights. These values are a summation of the modular contributions shown in Figure 8. For the CF6-6D, (Fig. 9), the performance deterioration value, based on hardware inspection results, at 1650 and 2500 flights was 2.3 percent and 2.4 percent in cruise SFC, respectively. These long-term performance deterioration values represent specific points in the life cycles of the JT9D and CF6 engines (specifically, 1) after the first flight of an engine on an airplane, 2) prior to the engine's first repair, and 3) at a point representative of additional flights following engine repair). In general, long-term deterioration occurs gradually with time as the engines are removed from the airplane, repaired, and returned to revenue service. As a function of aircraft flights, there is a sharp rise in SFC loss (short-term deterioration) followed by a gradual loss until the engine is repaired. Following the repair, during which some of the lost performance is restored (primarily in the HPT), the gradual loss is repeated until the engine is repaired again, etc.

A closer examination of the data from both engines reveals that the causes of long-term performance deterioration are additional blade tip clearance increases in all engine modules along with fan and compressor airfoil erosion/roughness. High and low pressure turbine thermal distortion is also a contributing source to the long-term performance deterioration.

As mentioned earlier, the assumptions used in these analyses were that only the HPT was repaired at every repair cycle and furthermore that all other modules remained intact for subsequent engine rebuilds after repair. Re-examining Figures 8 and 9 reveals that for the JT9D-3A/7/20 a potential of about 0.8 percent cruise SFC could be obtained with a HPT repair while for the CF6-6D the value is about 0.9 percent. These values for HPT repair are generally not realized in practice, however,

Mehalic
Ziemianski

because the data (4), (5), (6) indicates that not all performance deterioration is restored, there being a residual of approximately 0.2 percent cruise SFC deterioration remaining after each repair. (It should be noted for the CF6-6D that the HPT short-term deterioration, Fig. 9, does not normally happen following repair since the cause, hot rotor reburst, is not a normal operation, as mentioned earlier. Therefore, following repair at 1650 flights, HPT performance gradually deteriorates and accounts for about a 0.5 percent increase in SFC at 2500 flights, as shown in Figure 9.)

SPECIAL ENGINE TESTS - Several tests of JT9D and CF6 engines were conducted to expand the understanding of performance deterioration and more precisely assess modular contribution to the overall SFC loss (Table 3). Pratt & Whitney acquired pre- and post-repair performance data as well as parts condition information from 32 JT9D-7A engines in Pan American World Airways fleet of Boeing 747 SP aircraft. In addition, four of these engines were specially instrumented and periodically subjected to on-the-wing ground calibrations during their first 1000 cycles of operation (5). One of these engines (serial number (S/N) 743) was removed from the aircraft and subjected to extensive performance tests and hardware inspections (7). Analysis of the data from these efforts corroborated the historical data results which indicated that the JT9D exhibits a cruise SFC loss of about 0.7 percent during its early flight cycles, Table 3. The performance deterioration in the long-term (1000 cycles) was about 2.0 percent. Of the short-term deterioration that occurs during the early flight cycles, all was attributed to clearance increases throughout the engine. At 1000 flight cycles, about 50 percent of the performance deterioration is attributed to clearance increases while the remainder is caused by thermal distortion in the turbines and increased airfoil surface roughness in the fan and low pressure compressor.

Verification of historical CF6-6D short-term performance deterioration results was accomplished by a series of tests and inspections conducted with an engine that was removed from a DC-10-10 aircraft prior to delivery to American Airlines (8). This aircraft/engine had undergone the normal Douglas Aircraft Company acceptance test flights but had not been introduced into revenue service. The tests following removal of the engine (S/N 507) from the aircraft indicated an increase in cruise SFC of 0.9 percent over the level measured during engine production acceptance tests at General Electric, Table 3. Subsequent engine disassembly

Mehalic
Ziemianski

and detailed inspection revealed the short-term deterioration to be primarily a result of blade tip-to-shroud rubs causing increased clearance in the high pressure turbine module, again corroborating the historical data results.

Long-term performance deterioration of the CF6-6D engine, as shown in Table 3, was investigated through test and parts inspection of two engines: the first engine (S/N 479) after approximately 4000 hours of operation (1910 flights) prior to its first refurbishment and the second engine (S/N 380) prior to its third refurbishment, after 12000 hours of operation (3740 flights) (9), (10). The primary result of this investigation was the identification of the deterioration mechanisms that contribute to long-term deterioration (increased blade tip clearances, increased airfoil surface roughness and erosion, and distortion of parts). The amount of overall engine performance deterioration, although less conclusive than for the JT9D because of the small data sample, did fall within the statistical data band, Table 2.

Additional special testing of the CF6 was done to determine the contribution of individual modules and components (Table 3) to the overall increase in engine specific fuel consumption. Back-to-back tests of CF6 fans and low pressure turbine (LPT) modules established the amount of deterioration attributable to those components. The sequence in which the back-to-back tests were accomplished was: 1) test the engine in its as-received condition, 2) remove one specific module (fan or LPT), 3) repair the removed module or replace it with a new or refurbished one, 4) reassemble the module into the engine, and 5) retest the engine. Separate tests of two fans, in which the fan blades were cleaned and the leading edge recontoured, produced a 0.4 percent average reduction in cruise SFC from the pre-repair value. Six LPT modules with various operating times (11) were tested back-to-back with new and refurbished modules, and the average change in cruise SFC contributed by LPT deterioration was 0.4 percent. Inspection of the LPT modules disclosed the primary cause of the performance deterioration was clearance increases resulting from blade tip to shroud rubbing.

TESTING FOR SPECIFIC EFFECTS - Examination of the historical data and data from special engine tests and inspections corroborated the fact that a primary cause of engine performance deterioration was increased blade tip clearances throughout the engine. In both the short- and long-term the JT9D and CF6 engines exhibit a significant amount of performance deterioration resulting from increased running clearances.

Mehalic
Ziemianski

To this effect, investigations were initiated to better understand the cause and effect of increased clearances for both engines.

A major cause of increased clearances in the JT9D engine was believed to be flight loads (aerodynamic and inertial) transmitted to the engine during normal aircraft operations (take-off, landing, etc.), as shown in Figure 11. An integrated NASA Structural Analysis (NASTRAN) model of the JT9D/747 installation (Fig. 12) developed jointly by the Boeing Commercial Airplane Company (BCAC) and Pratt & Whitney, was used to predict engine structural deflections and fuel consumption increases resulting from various aircraft/engine flight profiles during quasi-steady engine operation (12). These profiles included representations of the aircraft flight acceptance test and normal revenue service operations. Estimates of the flight load magnitudes that might be expected during the flight profiles were provided by BCAC. In addition, the NASTRAN model was used to account for dynamic effects resulting from aircraft operation during gust encounters and hard landings (13).

The output of the NASTRAN analysis is in the form of structural deflections of the engine rotors and cases resulting from flight loads on the engine. The process by which these structural deflections were translated to performance losses (12), (13), (14) required the establishment of baseline or "hot running" clearances for the particular flight condition being analyzed. These baseline clearances took into account the effect of centrifugal forces and internal and external pressures and temperatures. The next step was to add to these clearances manufacturing offset grinds of the seals and any rub damage produced during the previous flight conditions. The resulting clearances are those that are available to accommodate structural deflections due to thrust and flight loads. Asymmetric rotor/stator deflections were then introduced from the NASTRAN analysis and when the relative closures exceeded the available gap, the extent of rub damage was recorded as circumferential uniform wear of the blade tips, and local wear of the rub strip. The trade-off between blade-tip/rub-strip damage was obtained by using empirically derived abrasibility factors. The resulting rub damage was then converted to an average clearance increase for each stage of the engine. The final step involved the conversion of these permanent clearance changes to increases in SFC by the use of influence coefficients unique to the JT9D engine. These coefficients relate blade tip clearance increases to performance loss (SFC).

Results of the NASTRAN analyses are shown

Mehalic
Ziemianski

in Table 4. As indicated, the nacelle aerodynamic (pressure) loads account for 87 percent of the total short-term engine performance deterioration (0.7 percent cruise SFC increase). Inertia loads, which affect the HPT and fan primarily, cause approximately 13 percent of the deterioration. The dynamic loads did not cause any significant changes in the steady loads analysis.

To acquire a better understanding of the effect of flight loads on engine running clearances and the associated performance deterioration, a sequence of analyses (theoretical) and tests (empirical) was developed (Fig. 13). For the simulated aerodynamic loads test, a specially prepared JT9D engine was instrumented to measure performance, clearances and case thermal gradients and subsequently installed in a high-energy X-ray facility (Fig. 14). This facility was modified with a specially designed loading device that used "belly-bands" around the engine nacelle, connected to cables that were used to apply simulated flight loads to the engine.

Extensive instrumentation (Fig. 15) provided the measurements necessary to assess performance deterioration on a modular basis. X-rays and laser proximity probes were used to measure blade tip and seal clearances. X-rays, both top and bottom, were taken at seven axial positions along the engine while laser proximity probes were available for nine stages (four circumferential locations per stage). In addition, 400 thermocouples and pressure taps were installed to measure engine case, flange, and cavity air temperature and pressure gradients. These temperature measurements were required to separate thermally induced clearance changes from those caused by externally applied structural loads.

The simulated aerodynamic load test program consisted of three sequences which were preceded and followed by performance calibrations and cold clearance measurements. The first test sequence involved the determination of changes in engine running clearances due to thermal and thrust loads. In the second test sequence, changes in engine static (cold) clearances were established as a function of simulated inlet aerodynamic loads. The third sequence involved operation of the engine at power while applying simulated inlet aerodynamic loads to determine the combined effect of thrust, thermal, and inlet loads on clearances. Following the tests the engine was disassembled and inspected to determine changes in build measurements so that measured performance changes could be correlated with hardware condition.

Mehalic
Ziemianski

Preliminary results from the simulated aerodynamic load test indicate the amount of performance deterioration was approximately 0.9 percent in cruise fuel consumption with a modular distribution as shown in Table 5. This is slightly higher than results from other parts of the program have indicated. However, it must be pointed out that the final analysis of the data has not been completed at the time this paper was prepared, and loads applied to the engine during the tests were estimated from a limited amount of flight test data.

The final step in the sequence to more fully understand the effects of flight loads on JT9D performance deterioration is a flight test using instrumented engines on a 747 aircraft (Fig. 13). The feasibility of several technical options for a flight test program were considered (15). For these tests an inboard and outboard engine will be instrumented (Fig. 16). The inboard engine instrumentation includes expanded performance measurements, clearance measurements with laser proximity probes in the fan and high-pressure turbine (HPT), and HPT case thermocouples. The outboard engine instrumentation consists of laser proximity probes in the fan in addition to normally installed engine performance measurements. Additional engine preparation for the flight tests includes an analytical build (i.e., documented condition and clearances) of the HPT and restored clearances in the fan at the inboard location and restored fan clearances at the outboard location.

The 747 to be used for the flight tests is the BCAC research aircraft RA001. The primary objective of this test is to measure the actual flight loads (aerodynamic and inertial) encountered during aircraft acceptance tests and normal revenue service operations. To this effect, in-flight aerodynamic loads on the inlets and nacelles will be measured by a series of strategically located pressure taps (252 at the inboard location and 45 at the outboard location). Gravitational and gyroscopic forces on the airplane center-of-gravity, the wing/strut intersection, and the engine will be measured using accelerometers and rate gyros. All data will be continuously monitored and recorded during the flight tests and time synchronized for correlation of clearance changes with load conditions.

Mehalic
Ziemianski

The testing sequence begins with a performance calibration of the inboard engine in a Pratt & Whitney test cell. Following installation on the aircraft, an installed engine ground calibration of both inboard and outboard engines is to be performed to obtain a baseline to reflect performance changes associated with the various test segments. After this calibration, the flight tests are to begin with a duplication of that portion of the normal aircraft acceptance flight profile that contributes to engine performance deterioration. During the flight test, loads and engine clearance changes will be measured simultaneously. Another installed engine ground calibration will be conducted after the acceptance flight to establish the level of engine performance deterioration resulting from the acceptance flight. In the final segment of flight tests airplane gross weight will be varied to establish the effects on engine performance deterioration of take-offs and landings and high "g" maneuvers (wind-up turns) which might be encountered during airline revenue service operations. A final installed engine ground calibration will then be conducted to determine the total engine performance change due to the flight load tests. Following this final installed calibration, the inboard test engine will again be calibrated in a Pratt & Whitney test cell and then undergo an analytical teardown/inspection to measure clearance changes to assist in the correlation of measured flight loads with clearance/performance changes. The flight testing is scheduled to occur during October 1980.

Results from the flight test and JT9D aerodynamic load tests in the X-ray facility will be used to refine the NASTRAN structural model. This model should then assist in the development of design criteria to minimize engine performance deterioration.

HPT AND HPC CLEARANCE INVESTIGATIONS -

The effects of clearance changes on CF6 performance are being investigated in two areas: the high-pressure turbine (HPT) and the high-pressure compressor (HPC). The predominant mode of CF6 short-term performance deterioration is clearance increases caused by rubs in the HPT, while in the long-term approximately one-half of the performance losses in the HPT and HPC are attributable to increased clearances.

The HPT clearance investigation will be run on a CF6 engine. The engine instrumentation will include pressure and temperature

Mehalic
Ziemianski

measurements to determine performance, and laser clearanceometer probes will be employed to measure blade tip-to-shroud clearances in the 1st stage of the HPT. The tests will be structured to produce increasing turbine tip clearances by incurring blade tip-to-shroud rubs through progressively more severe transient operations. These engine operations include idle, steady state operations at various power levels, accelerations and decelerations to and from takeoff power, re-bursts to takeoff power, and a fuel shutoff at takeoff power. These tests will allow the effect of varying HPT clearances on performance to be accurately determined. The results will enable updating of analytical methods and assumptions to enhance future refurbishment or design criteria.

The sensitivity of HPC performance to clearance changes will be determined during tests of a CF6 core engine. Clearance variations, measured by capacitance-type clearanceometers, will be accomplished by flowing cooling air through the compressor rotor internal cavity to adjust thermal growth under steady-state operating conditions. In addition, the transient clearance behavior of the compressor will be investigated during engine acceleration and deceleration. The test results from this program will provide a better understanding of the degree of performance deterioration associated with tip clearance variations, and will influence future refurbishment and design criteria.

These HPT and HPC clearance investigations were scheduled to occur during the summer of 1980 and the results were not available.

PROGRAM RESULTS

The results of the program to date are documented in Figure 17 as a composite curve and labeled "NASA Program Results - Average data (JT9D and CF6)". The assumption used to develop the composite curve was that the rate of deterioration between the data points was linear, (e.g., short-term to first repair). This assumption of linearity was made because the exact shape could not be precisely defined in the NASA engine diagnostic studies (4), (5), (6). The upper curve represents the original industry estimates (16), (17) (circa 1974), prior to the NASA Program. Comparing the two reveals that the original estimate of performance deterioration was high by at least a factor of two.

Mehalic
Ziemianski

As a part of the NASA Engine Diagnostics program, cost effective feasibility studies were also conducted which, when extrapolated to today's fuel price (approximately 25 cents per liter), reveal that 80 percent of the 2% cruise SFC currently unrestored after each engine repair/overhaul was cost-effective to restore. In addition, remedial hardware modifications were recommended to minimize the short and long-term performance deterioration.

CONCLUDING REMARKS

The NASA Engine Diagnostics Program results revealed wide variations in the performance deterioration rates for individual engines in both the JT9D and CF6 engine families. The prime contributing factor to this variation is believed to be the "on-condition maintenance" concept which permits selective repair and interchange of engine modules during engine repair/overhaul. The results presented in this paper are a representation of the average deterioration characteristics of the JT9D-3A/7/20 and CF6-6D engines. Testing for specific effects is continuing and, therefore, the results are not final. Analysis of these carefully documented engine tests may suggest revisions to some of the findings.

In summary, some of the most important results to date reveal the following:

1. Short-term performance deterioration is less than 1 percent cruise SFC. The causative factors are either flight loads (JT9D) or thermal mismatches (CF6) which result in rubs between blade tips and stationary shrouds.
2. Long-term performance deterioration occurs gradually and is about 2.5 to 3.0 percent cruise SFC (including initial short-term deterioration) after 2500 to 3000 flights. The long-term losses are associated with more severe rubs, airfoil quality degradation, and parts distortion.

REFERENCES

1. Fuel Cost and Consumption, Monthly Reports. Civil Aeronautics Board.
2. Richard G. O'Lone, "Fuel Shortage Causing Concern", Aviation Week and Space Technology, March 3, 1980.
3. Donald L. Nored, James F. Dugan, Neal T. Saunders and Joseph A. Ziemianski, "Aero-propulsion 1979 - Aircraft Energy Efficiency (ACEE) Status Report", NASA Conference

Mehalic
Ziemianski

Publication 2092, October 1979.

4. G. P. Sallee, "Performance Deterioration Based on Existing (Historical) Data - JT9D Jet Engine Diagnostics Program", NASA CR-135448, April 20, 1978.
5. G. P. Sallee, "Performance Deterioration Based on In-Service Engine Data-JT9D Jet Engine Diagnostics Program", NASA CR-159525, April 27, 1979.
6. Ray H. Wulf, "CF6-6D Engine Performance Deterioration", NASA CR-159786, January 1980.
7. R. J. Bouchard, W. R. Beyerly and G. P. Sallee, "Short-Term Performance Deterioration in JT9D-7A(SP) Engine 695743 - JT9D Jet Engine Diagnostics Program", NASA CR-135431, June 30, 1978.
8. W. H. Kramer, J. E. Paas, J. J. Smith and R. H. Wulf, "CF6-6D Engine Short-Term Performance Deterioration", NASA CR-159830, March 1980.
9. W. H. Kramer and J. J. Smith, "Long-Term CF6 Engine Performance Deterioration - Evaluation of Engine S/N 451-479", NASA CR-135381, February 1978.
10. W. H. Kramer and J. J. Smith, "Long-Term CF6 Engine Performance Deterioration - Evaluation of Engine S/N 451-380", NASA CR-159390, August 1978.
11. J. J. Smith, "Long-Term CF6-6D Low Pressure Turbine Deterioration", NASA CR-159618, August 1979.
12. A. Jay and E. S. Todd, "Effect of Steady Flight Loads on JT9D-7 Performance Deterioration - JT9D Jet Engine Diagnostics Program", NASA CR-135407, June 9, 1978.
13. A. Jay and B. L. Lewis, "Effect of Time-Dependent Flight Loads on JT9D-7 Performance Deterioration - JT9D Jet Engine Diagnostics Program", NASA CR-159681, August 21, 1979.
14. E. G. Stakolich, A. Jay, E. S. Todd, P. G. Kafka and J. L. White, "Effect of Flight Loads on Turbofan Engine Performance Deterioration", NASA TM-79041/ASME Technical Paper, March 11-15, 1979.
15. G. P. Sallee and R. L. Martin, "Expanded Study of Feasibility of Measuring In-Flight 747/JT9D Loads, Performance, Clearance, and Thermal Data", NASA CR-159717, September 28, 1979.
16. Aircraft Fuel Conservation Technology Task Force Report, Office of Aeronautics and Space Technology, National Aeronautics and Space Administration, Washington, DC 20402, September 10, 1975.

Mehalic
Ziemianski

17. Aircraft Fuel Efficiency Program - Hearing
Before the Committee on Aeronautical and
Space Sciences, United States Senate, Ninety-
Fourth Congress, First Session, September 10,
October 23, and November 4, 1975., U. S.
Government Printing Office, Washington, DC
20402.

Mehalic
Ziemianski

TABLE 1. - ENGINE CHARACTERISTICS

Engine	JT9D-7	CF6-6D
Max Power at Sea Level (Dry)	202,829N (45,600 lb)	177,920 N (40,000 lb)
Total Airflow	696 kg/s (1534 lb/s)	591 kg/s (1302 lb/s)
Overall Pressure Ratio	22.5	24.4
By-Pass Ratio	5.1	5.72
No. of Compression Stages		
Fan	1	1
Low	3	1*
High	11	16
No. of Turbine Stages		
High	2	2
Low	4	5
No. of Combustion Stages	1	1
Application	Boeing 747, 747SP, 747SR	DC-10-10

*Designated as a Quarter Stage

TABLE 2. - PERFORMANCE DETERIORATION
AVERAGE VALUES/STATISTICAL VARIATIONS

Δ % CRUISE SFC

Period	JT9D-3A/7/20			CF6-6D		
	Flights	Avg.	SEE	Flights	Avg.	SEE
Short-Term	1	0.7	±0.3	1	0.8	±0.6
Long-Term	1000	2.0	±0.8	1650	2.3	±1.1
Long-Term	3000	3.0	±0.8	2500	2.4	±1.1

SEE-Standard Error of Estimate (Root-Mean-Square of Deviations About a Fitted Curve)

TABLE 3. - SPECIAL ENGINE TEST RESULTS

Period or Module	Engine	Serial No.	Flights	Avg Δ Cruise SFC, %	Primary Cause of Deterioration
Short-term	JT9D CF6	743	141	0.7	● Clearance Increase
		507	4	0.9	
Long-Term	JT9D CF6 CF6	(1)	1000	2.0	● Clearance Increase/ ● Airfoil Quality/ Distortion
		380	1270 (2)	2.2	
		479	1910	3.1	
Fan (2 Tests)	CF6		1910- 3740	0.4 (AVG)	● Airfoil Quality (Leading Edge Bluntness & Dirt)
LPT (6 Tests)	CF6		2180- 7444	0.4 (AVG)	● Clearance Increases

(1) 8 A/C 32 Engines (2) Flights Since Last Repair (3740 Total Flights Since New)

TABLE 4. - JT9D/747 Propulsion
System Structural Analysis

Steady State Results		
Loads	Engine Components Affected	% of Total SFC Loss
Nacelle Aerodynamic Inertia	All	87
"G"	HP Turbine	8
Gyro	Fan	5
Dynamic Results		
Wind Gust Encounters	No Significant Change From Steady State	
Revenue Service Landing		

TABLE 5. - JT9D AERODYNAMIC LOAD TEST

Preliminary Results	
Module	SFC Increase, %
Fan	0.1
LPC	0.2
HPC	0.1
HPT	0.4
LPT	0.1
Total	0.9

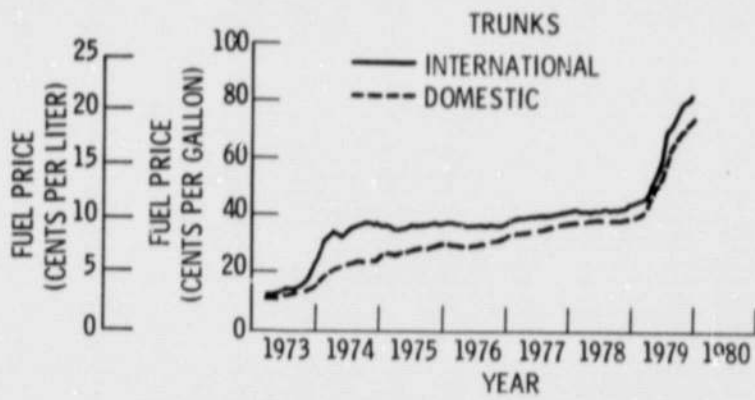
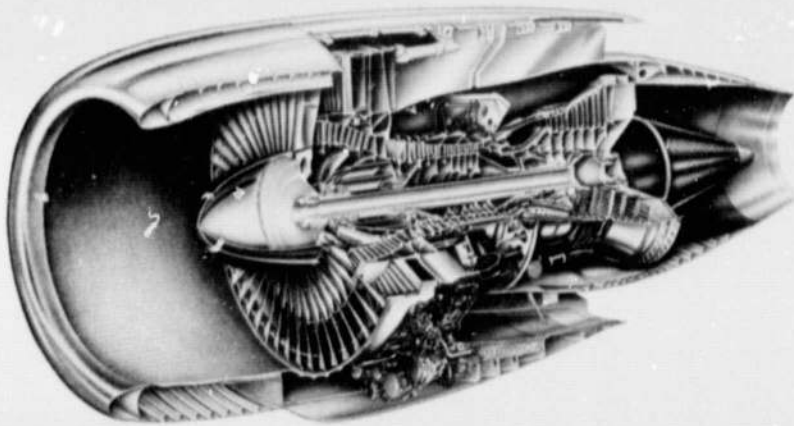

Figure 1. - Fuel cost history. U. S. Airline jet fuel price monthly averages. CAB data.



C-76-2293

Figure 2. - The JT9D propulsion package.

ORIGINAL PAGE IS
OF POOR QUALITY

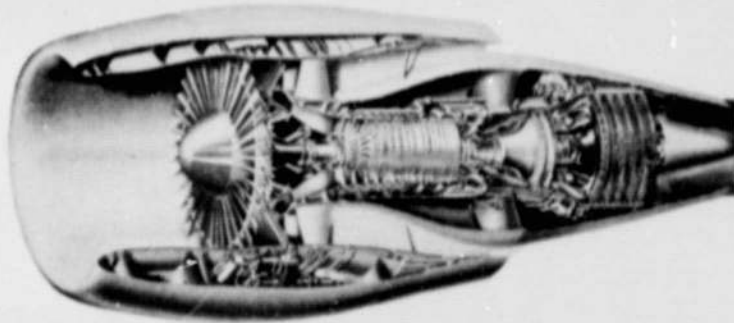

C-76-2294

Figure 3. - The CF6-6 propulsion package.

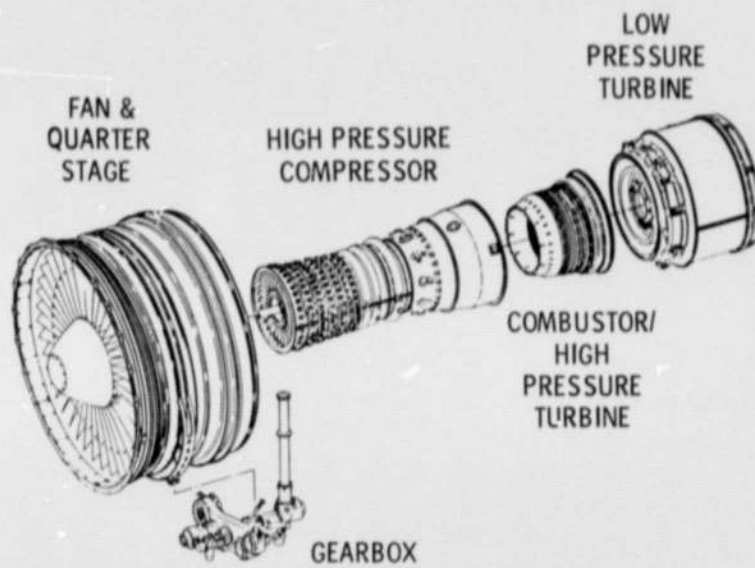

Figure 4. - CF6 engine modular design.

GENERAL ELECTRIC

GE/EVENDALE
GE/ONTARIO
COOPER AIRMOTIVE
DOUGLAS AIRCRAFT
AMERICAN AIRLINES
CONTINENTAL AIR LINES
NATIONAL AIRLINES
UNITED AIR LINES
WESTERN AIR LINES

PRATT & WHITNEY

P&W ENGINEERING
P&W SERVICE CENTER
BOEING
DOUGLAS AIRCRAFT
AMERICAN AIRLINES
NORTHWEST AIRLINES
PAN AMERICAN WORLD
AIRWAYS
TRANS WORLD AIRLINES
UNITED AIR LINES
PACIFIC AIRMOTIVE

Figure 5. - Data sources.

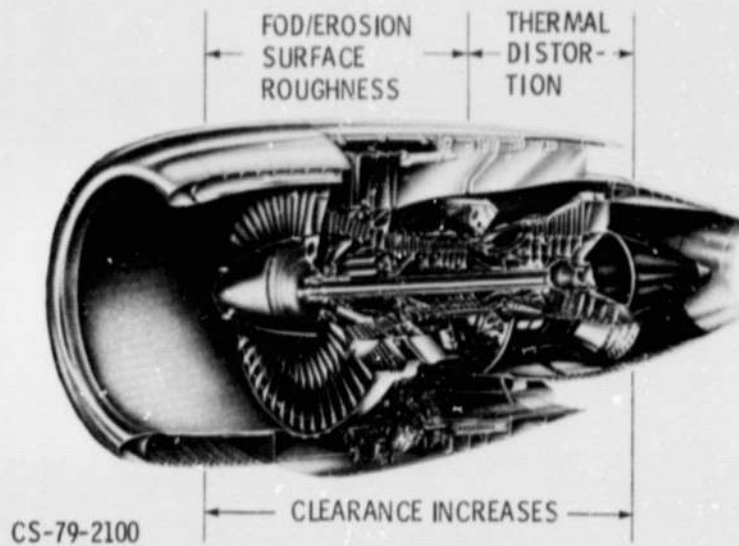

Figure 6. - Contributors to engine performance deterioration.

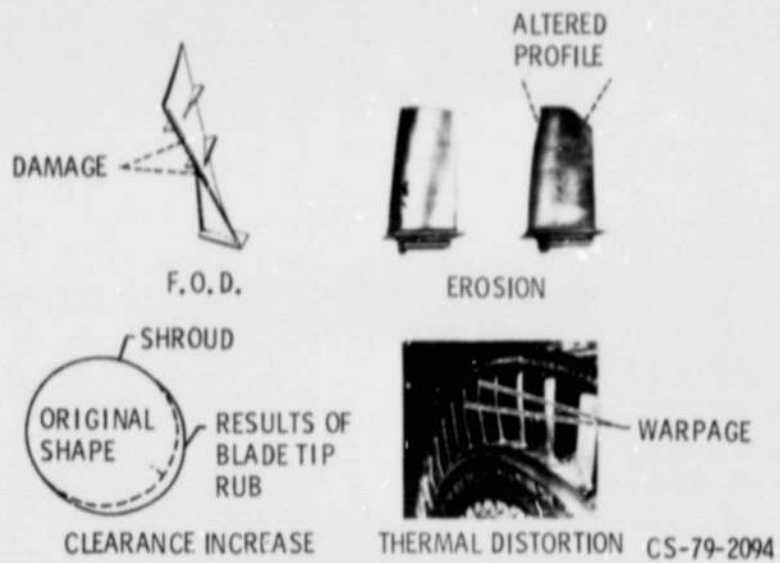

Figure 7. - Examples of engine performance deterioration.

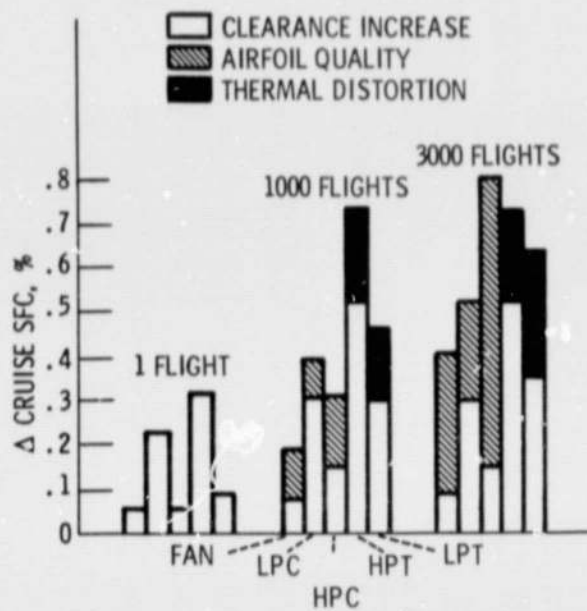

Figure 8. - JT9D-3A/7/20 performance deterioration. Modular contribution.

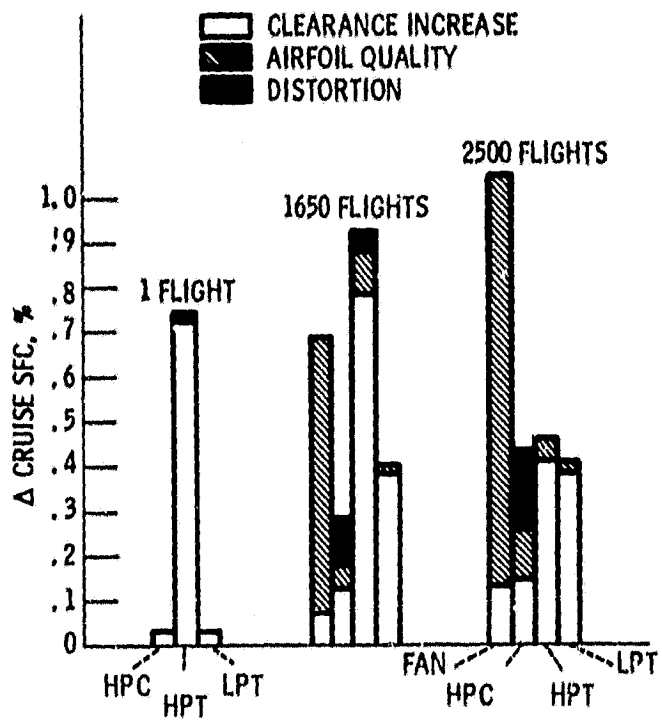

Figure 9. - CF6-6D performance deterioration. Modular contribution.

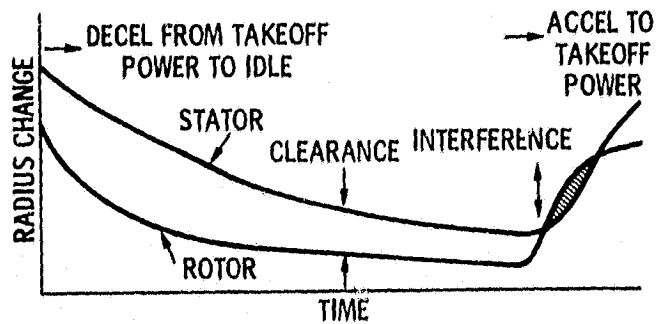

Figure 10. - Hot rotor reburst. HPT clearance.

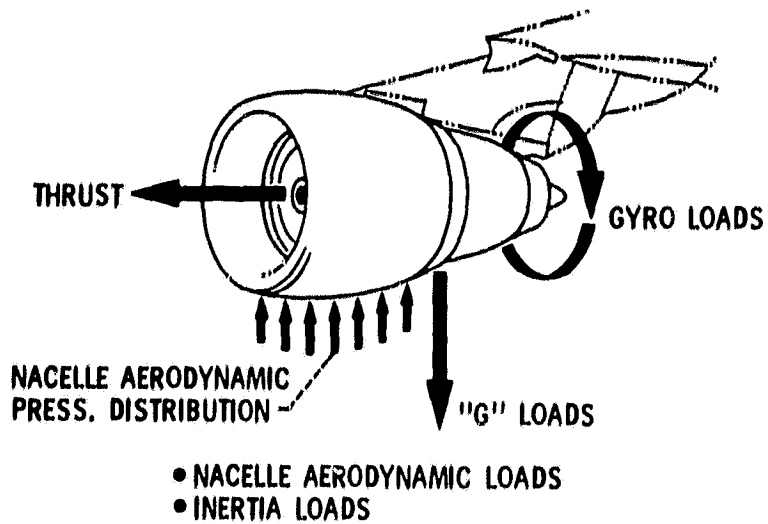

Figure 11. - JT9D external applied loads and reactions.

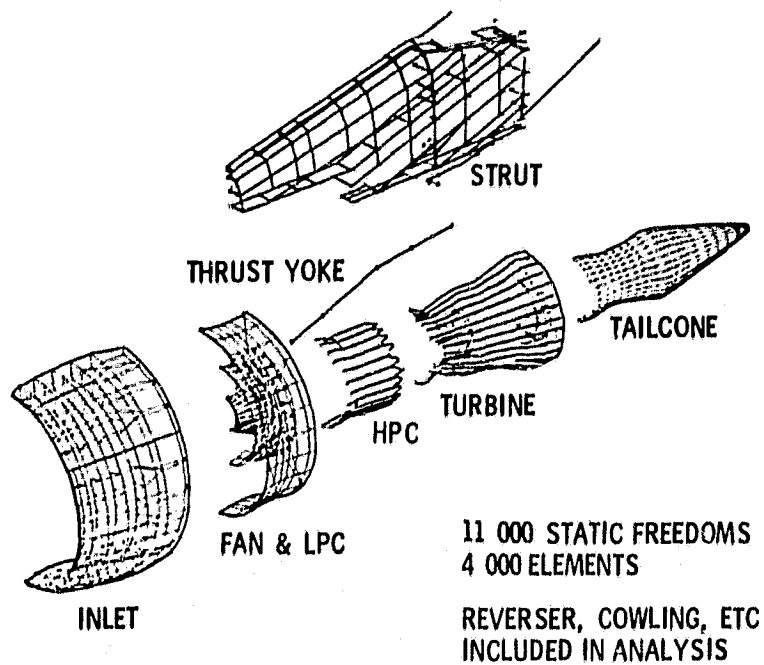

Figure 12. - JT9D/747 propulsion system structural model.

INVESTIGATIVE SEQUENCE

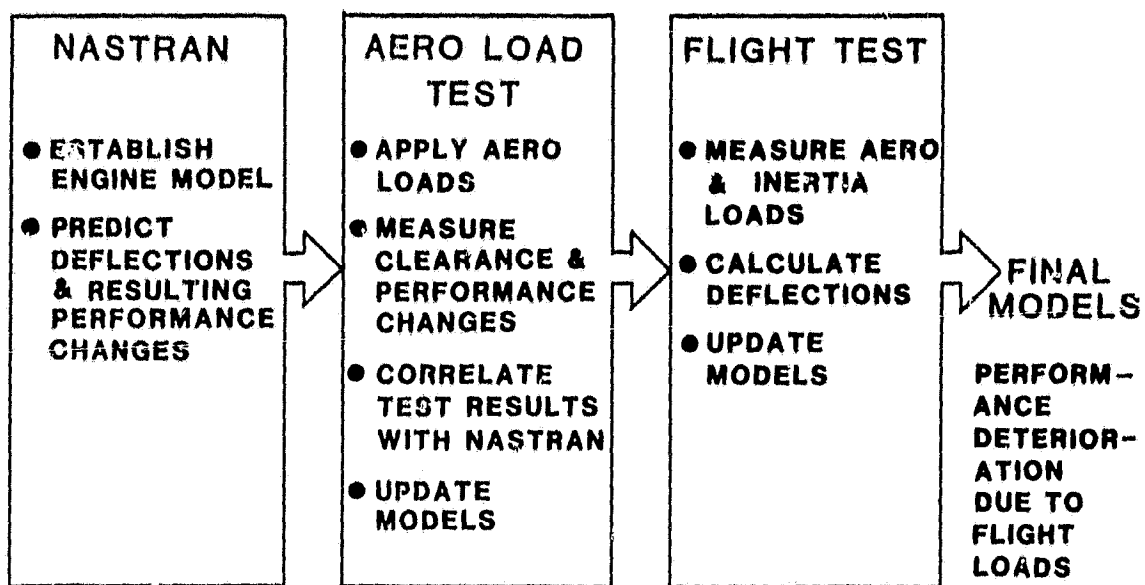

Figure 13. - Effects of flight loads JT9D/747 propulsion system.

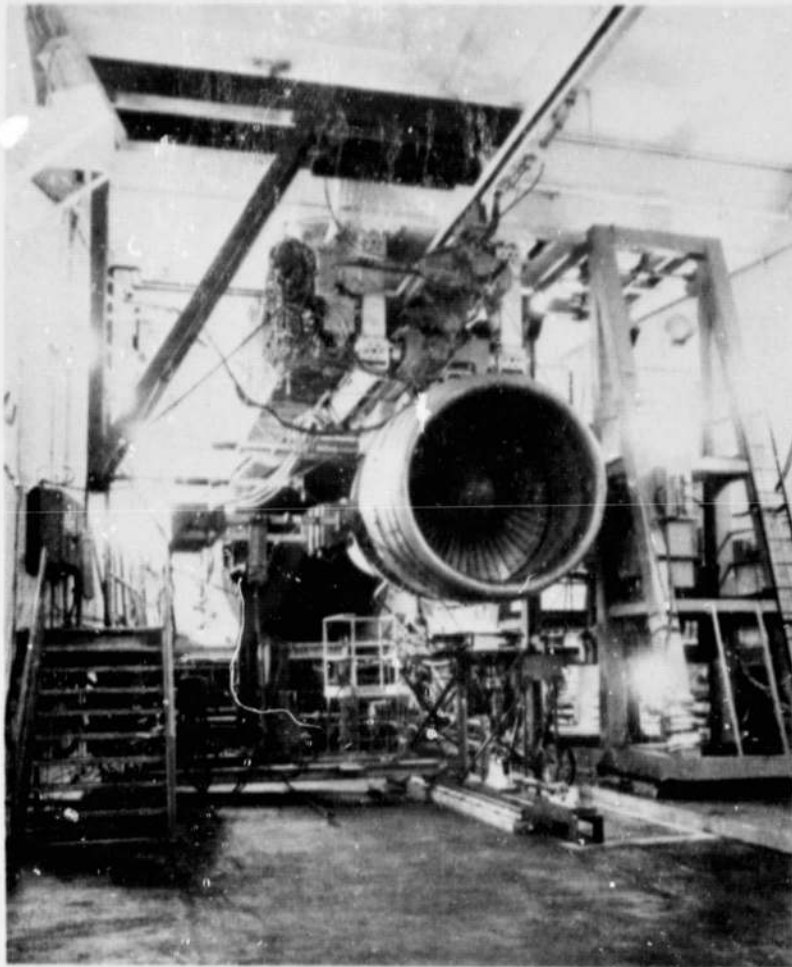

Figure 14. - JT9D engine installed in X-ray facility.

ORIGINAL PAGE IS
OF POOR QUALITY.

INSTRUMENTATION

CLEARANCE MEASUREMENTS

- o X-RAY SYSTEM
- o LASER PROXIMITY PROBES - 9 STAGES, 4 PER STAGE FAN,
LPC (4TH STAGE) HPC (5, 6, 9, 10, 11 AND 14 STAGES),
HPT (1ST STAGE)

PERFORMANCE MEASUREMENTS

- o ALL STATIONS T_T , P_T , AND P_s
- o N_1 , N_2 , F_N , W_F

ENGINE CASE THERMALS

- o HPC, DIFFUSER, HPT, LPT, TURBINE EXHAUST CASES
- o 400 CASE, FLANGE, AIR CAVITY THERMOCOUPLES AND PRESSURES

Figure 15. - JT9D aerodynamic load test.

INSTRUMENTATION

	<u>ENGINE (OUTBOARD)</u>	<u>ENGINE (INBOARD)</u>
BOEING		
INLET (INTERNAL AND EXTERNAL) PRESSURE PROBES	45	252
ACCELEROMETERS	12	12
RATE GYRO	2	2
PRATT & WHITNEY		
EXPANDED ENGINE PERFORMANCE	NO	YES
FAN CLEARANCE PROBES	4	4
HPT CLEARANCE PROBES	--	4
HPT CASE TEMPERATURE T/C	--	20

Figure 16. - JT9D propulsion system flight test.

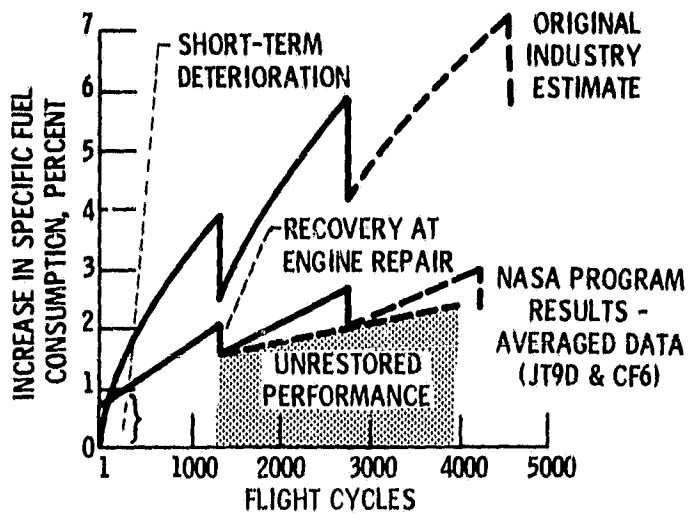

Figure 17. - SFC performance deterioration trend.
Typical engine.