

# Performance Evaluation of Phasor Measurement Systems

Zhenyu Huang, *Senior Member, IEEE*, Bogdan Kasztenny, *Fellow, IEEE*, Vahid Madani, *Fellow, IEEE*, Ken Martin, *Fellow, IEEE*, Sakis Meliopoulos, *Fellow, IEEE*, and Damir Novosel, *Fellow, IEEE*, Jerry Stenbakken, *Member, IEEE*

**Abstract**--After two decades of phasor network deployment, phasor measurements are now available at many major substations and power plants. The North American SynchroPhasor Initiative (NASPI), supported by the US Department of Energy and the North American Electric Reliability Corporation (NERC), provides a forum to facilitate cultivating the efforts in phasor technology in North America and globally. Phasor applications have been explored and some are in today's utility practice. The IEEE C37.118 Standard is a milestone in standardizing phasor measurements and defining performance requirements. To comply with the IEEE C37.118 and to better understand the impact of phasor quality on applications, the NASPI Performance and Standards Task Team (PSTT) has prepared two comprehensive documents which leverage prior industry work (esp. in WECC) and international experience. The first document describes PMU testing based on both IEEE C37.118 requirements and required dynamic performance tests. The second document describes characterization of PMUs and instrumentation channels based on practical information. This paper summarizes the accomplished PSTT work and presents the methods for phasor measurement evaluation to assure consistent PMU system performance.

**Index Terms**--Synchronized Phasor Measurements, Phasor Measurement Unit, PMU Testing and Characterization, North American SynchroPhasor Initiative (NASPI).

## I. INTRODUCTION AND BACKGROUND

SINCE the introduction of computer relaying and later microprocessor relays, efforts were initiated to extract the phasors of an electric power system [1][2][3], using the available time signals at the time. Phasor measurements hold

This paper is a summary of comprehensive collective efforts of the members of the North American SynchroPhasor Initiative (NASPI) Performance and Standards Task Team (PSTT), supported in part by the U.S. Department of Energy Consortium for Electric Reliability Technology Solutions (CERTS). Representatives from the PSTT have prepared this paper.

Z. Huang is with Battelle – Pacific Northwest National Laboratory, Richland, WA 99352 USA (e-mail: zhenyu.huang@pnl.gov). The Pacific Northwest National Laboratory is operated by Battelle for the U.S. Department of Energy under Contract DE-AC06-76RL01830.

B. Kasztenny is with General Electric, Canada.

V. Madani is with Pacific Gas & Electric Co., USA.

K. Martin is with Bonneville Power Administration, USA.

S. Meliopoulos is with Georgia Institute of Technology, USA.

D. Novosel is with Quanta Technology, USA (email: dnovosel@quanta-technology.com).

J. Stenbakken is with the National Institute of Standards and Technology, USA.

the promise of being superior to traditional Supervisory Control and Data Acquisition (SCADA) measurements in capturing system dynamic behaviors, as phasor measurements are high speed and time synchronized. Phasor measurement systems were developed and deployed on an experimental basis in actual power systems in North America in the 1990's. This experience led to the commercial development of phasor measurement units (PMUs) with precise time synchronization.

Commercial PMUs were then installed in both the eastern and western systems in North America [4][5][6][7][8][9][10]. The value of phasor measurement has been demonstrated through these efforts. In 2002, the DOE launched a demonstration project – Eastern Interconnection Phasor Project (EIPP) – to initiate large-scale deployment of a phasor network in the Eastern Interconnection by leveraging WECC WAMS experience. A working group was formed to facilitate the effort. The August 14, 2003 blackout reinforced the value of synchronized phasor measurements for enhancing situational awareness [11].

In 2007, the North America efforts in phasor technology were combined and the North American SynchroPhasor Initiative (NASPI) emerged with the intent to coordinate phasor activities in the entire North America. The increased role for industry collaborations of the NASPI working group and task teams has already extended to a more global collaboration of industry best practices while the DOE continues to support phasor research. Today, there are seven task teams focusing on various aspects of phasor activities. Amongst the task teams is the Performance and Standards Task Team (PSTT). The PSTT is chartered to coordinate and act as liaison to standardization efforts and to determine consistent and satisfactory performance of synchronized measurement devices and systems by creating guidelines and reports in accordance with best practices. Many of the PSTT members are active in many international industry activities which help the Task Team members to coordinate the development of phasor-related standards both within the NASPI as well as outside of the North America.

Currently, there are about 140 phasor monitoring the North America Grid with equally distributed PMUs in the west and east. Many phasor applications are being proposed [12][13] and application challenges for precision protection and control are highlighted, targeting various aspects of power

grids, including steady state applications like state estimation [14] and dynamic monitoring like modal analysis [15].

There are currently a number of companies manufacturing PMUs. PMU hardware from different manufacturers is likely implemented differently, potentially resulting in inconsistency and various levels of phasor quality. Phasor performance is also affected by instrumentation channels from sensors at the bus or line to the user. On the other hand, different applications would have different requirements regarding phasor quality. The WECC WAMS clearly defines the requirements of synchronized measurements for the purpose of dynamic monitoring [16]. The publication of IEEE C37.118 SynchroPhasor Standard [17] is an important step in standardizing phasor measurements. However, further work is needed as C37.118 is not enough in evaluating phasor performance. For example, C37.118 is focused on steady-state characterization.

In view of the need for developing complementary documents to the IEEE C37.118, the PSTT team initiated and accomplished the development of two important documents: PMU Testing Guide [18] and SynchroPhasor Accuracy Characterization [19]. This paper briefly summarizes these two documents and present methods for evaluating phasor performance in both steady-state and dynamic situations as well as from PMU hardware to instrumentation channels.

## II. OVERVIEW OF PHASOR MEASUREMENT SYSTEMS

Figure 1 illustrates the devices forming voltage and current phasor measurements typically found in electric power generating stations and substations. The devices consist of two major parts: a PMU and the balance referred to as instrumentation channel including instrument transformers, control cables, and burdens. Ideally, it is expected that the instrumentation channel will produce at the output a waveform that will be an exact replica of the high voltage or current and scaled by a constant factor. In reality, the instrumentation channel introduces an error and contributes to signal degradation to some degree. Furthermore, the error introduced by one device may be affected by interactions with other devices of the channel. It is thus important to characterize the overall channel error.

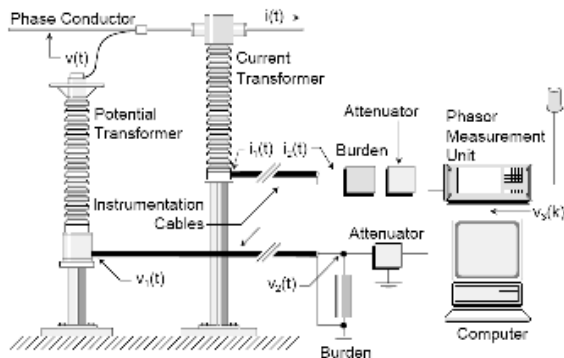
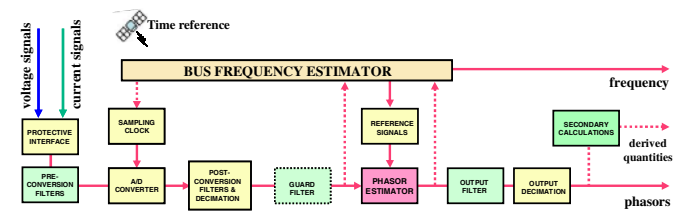

Figure 1 Typical potential and current instrumentation channels

The core logic in a PMU is the projection of point-on-wave

voltage and current signals onto a set of reference waveforms, known as complex modulation. PMU design must consider the frequency range of signal components to enter and exit the instrument, and how to present appropriate average values for varying phasor parameters. Figure 2 shows the general structure and nomenclature of PMU hardware [20]. Given the complexity in the power system signal environment, good filtering is needed in actual PMU logic, but options of filtering can be many. The indicated logic for “Bus Frequency Estimator” can be as simple as a smoothed numerical derivative of bus angles, or it can be a complicated frequency tracking function used to achieve a uniform number of samples for each cycle of system operating frequency and thereby desensitize the instrument gain to frequency changes. Since PMU logic contains those complex processing steps and the implementation can vary to a great extent, it is necessary to evaluate the performance of a PMU.



NOTE: Indicated filters may be accompanied by decimation without actual filtering

Figure 2 General structure for a phasor transducer

In response to the needs for evaluating phasor performance, the NASPI PSTT team has made significant progress in developing guidelines, leveraging prior work (esp. in WECC) and international experience, to address how the evaluation should be performed. These guidelines are intended to supplement existing standards for the purpose of procurement specifications and regulatory standards, so as to help users that plan to install PMUs or consider using phasor measurements for specific applications to ensure required phasor quality and phasor inter-operability.

## III. LABORATORY TESTING OF PMUS

Laboratory testing of PMUs includes two major aspects: steady-state testing and dynamic testing, which intends to evaluate PMU performance with a set of laboratory testing equipment. In WECC, BPA in collaboration with the DOE Pacific Northwest National Laboratory (PNNL) has developed and practiced laboratory testing technology in support of WECC certification of PMUs for more than a decade [16]. The US National Institute of Standards and Technology (NIST) initiated a standardization effort to characterize PMU performance [21]. Several other testing efforts [22][23] contributed to the area of PMU laboratory testing. The NASPI PSTT group consolidated all these efforts and developed the PMU Testing Guide [18].

PMU laboratory testing equipment consists of the following components (Figure 3):

- A time reference: The best time reference source is a

good quality GPS receiver with a GPS antenna. Good reception of GPS signals is needed to ensure the timing accuracy.

- A signal generator: It should be able to generate multi-phase steady state and dynamic signals with specified accuracy for magnitude, phase, frequency, phase balance, and rate of change in these parameters.
- A data collection device: The data collection device receives phasor measurements from the PMU and transmits to analysis tools in appropriate formats. It can be a phasor data concentrator (PDC) or just a PC which has proper software reading the PMU data format.
- Analysis tools: A set of tools are needed to parse the PMU data and analyze them per testing specifications so the PMU performance can be characterized.

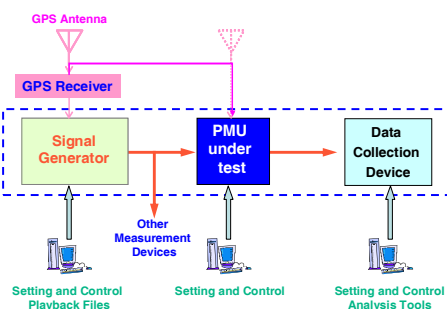

Figure 3 General structure of laboratory testing setup

If defined, the steady-state tests shall be performed according to the signal range and test conditions specified in C37.118 Table 3. In this context, these steady-state tests are conformance tests to evaluate PMU performance against defined criteria in the IEEE C37.118 Standard. In contrast, other steady-state and dynamic tests are termed performance tests, for which the criteria are yet to be developed.

#### A. Steady-state PMU testing

For steady-state tests, the signals have a constant amplitude and frequency during the data collection part of the test. The steady-state tests are conducted to confirm that the accuracy of a PMU is within the specified limits when exposed to specified steady-state operating conditions. The IEEE C37.118 Standard clearly defined the Total Vector Error (TVE) metric, and established the level 0 and level 1 compliance requirements under steady-state conditions for a PMU [17]. These compliance requirements define the TVE level for phasor magnitude measurement, phasor angle measurement, harmonic distortion and out-of-band interference.

The following types of steady-state tests are proposed in the PSTT PMU Testing Guide [18]:

- Magnitude accuracy test\*
- Phase accuracy test\*
- Frequency accuracy test\*
- Rate of change of frequency accuracy test
- Unbalanced magnitude response test

- Unbalanced phase response test
- Off-nominal frequency response test\*
- Harmonic frequency response test\*: To evaluate PMU performance in response to harmonic signals.
- Out-of-band interference test\*: To evaluate PMU performance in response to signals with frequency outside the pass band of the PMU's filtering characteristics.
- Data reporting test: This is to confirm the PMU phasor protocol (e.g. C37.118), phasor reporting rate (e.g. 30 samples per second), and fractional second values corresponding to the reporting rate.

where “\*” denotes conformance tests and others are performance tests. Figure 4 shows the voltage magnitude test result of a sample PMU.

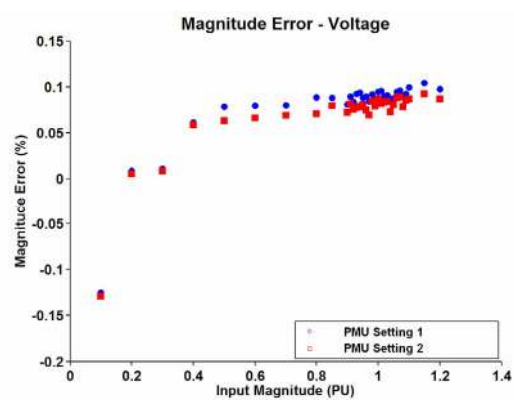

Figure 4 Example of voltage magnitude conformance test

#### B. Dynamic PMU testing

For dynamic tests, the amplitude or frequency of the signals varies during the test. IEEE C37.118 Standard does not establish compliance requirements under dynamic conditions. However, its informative Annex C describes several dynamic tests without conformance specifications. In this context, dynamic tests are performance tests in contrast to conformance tests. In many phasor applications, consistent dynamic performance among all PMUs in an interconnected system is of a great importance in addition to their steady-state performance. For example, a system that measures and records phasors for post-event small signal stability analysis of system dynamics during a large system disturbance, where system frequencies at different locations could change dynamically, would require the PMUs to be able to follow the frequency change quickly and consistently among all PMUs. One of the key aspects of PMU dynamic performance is its filtering characteristic. Figure 5 shows a 4<sup>th</sup>-order Butterworth filter with a 12 Hz bandwidth and the WECC filtering requirements for a PMU output rate of 60 samples per second. Some other related references include WECC practice as addressed in [24][25].

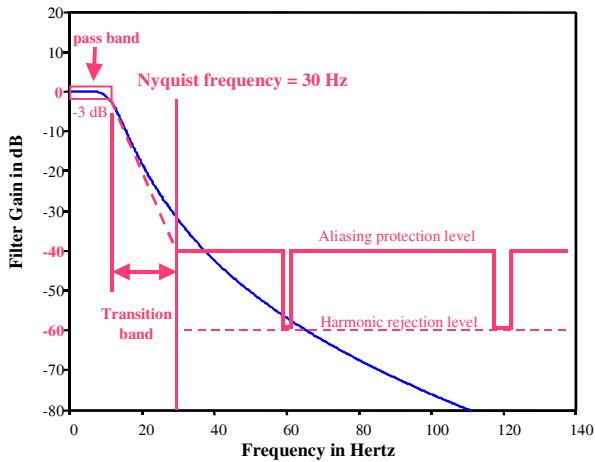

Figure 5 WECC filtering requirements (red) with the characteristics of an example 4<sup>th</sup>-order Butterworth filter (blue) (Note: sample rate = 60 samples per second)

The following types of dynamic tests are proposed:

- Dynamic magnitude response test: To characterize PMU performance in terms of rising time, settling time, and overshoot in response to a step change in the magnitude of an input signal.
- Dynamic phase response test: To characterize PMU performance in terms of rising time, settling time, and overshoot in response to a step change in the phase angle of an input signal.
- Dynamic frequency response test: To characterize PMU performance in terms of rising time, settling time, and overshoot in response to a step change in the frequency of an input signal.
- Voltage amplitude modulation test: To evaluate PMU performance in response to amplitude-modulated sinusoidal signals, mimicking power system oscillations.
- Frequency modulation test: To evaluate PMU performance in response to frequency-modulated sinusoidal signals, mimicking power system oscillations.

Two new models have been developed to analyze dynamic/modulated waveforms for their time-synchronized parameters. The Taylor Expansion model [26] works well for modulation frequencies below a few Hz. The three-waveform model [27] works well for modulation frequencies above one Hz. Together they allow accurate characterization of modulated waveforms from fractions of a Hz to over 130 Hz. The three-waveform model provides both the fundamental phasor – the one used for steady-state calibrations, and the dynamic phasor – the one that varies in magnitude and phase with the modulation frequency. As an example, Figure 6 shows the TVE for a commercial PMU relative to the fundamental and dynamic phasors. The dark blue curve is the TVE between the phasor measured by the PMU and the fundamental phasor estimated by the signal model, and the magenta one is the TVE between the measured phasor and the dynamic phasor estimated by the signal model. The drops are

processing artifacts at the Nyquist frequency (10 Hz) and the sampling frequency (20 Hz). As expected, at low modulation frequencies the PMU agrees well with the dynamic phasor and at high modulation frequencies, above half the PMU reporting rate, the PMU agrees well with the fundamental phasor.

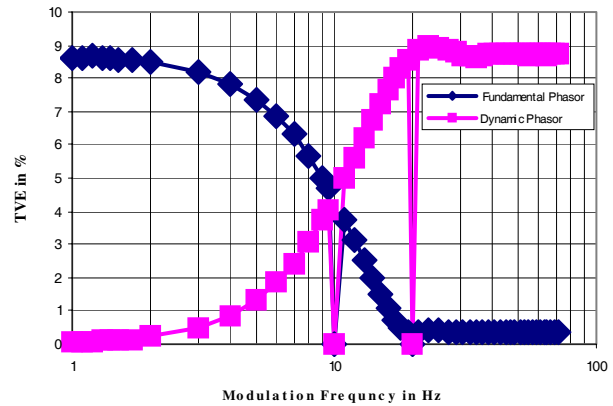

Figure 6 TVEs for a PMU relative to fundamental and dynamic phasors for a voltage signal with both 10% phase modulation and 10% amplitude modulation from 1 Hz to 71 Hz

It is worth pointing out that sometimes the various measurement functions exhibit interference between them. Figure 7 shows an example of voltage amplitude modulation tests. The voltage amplitude measurement captures the modulation reasonably well below the Nyquist frequency (15 Hz for a data rate of 30 samples per second) and suppresses the signal above the Nyquist frequency. However, the frequency measurement, which is supposed to be 60.06 Hz constant, shows modulated signals resembling those in the voltage magnitude measurement and unexpected drop above the Nyquist frequency.

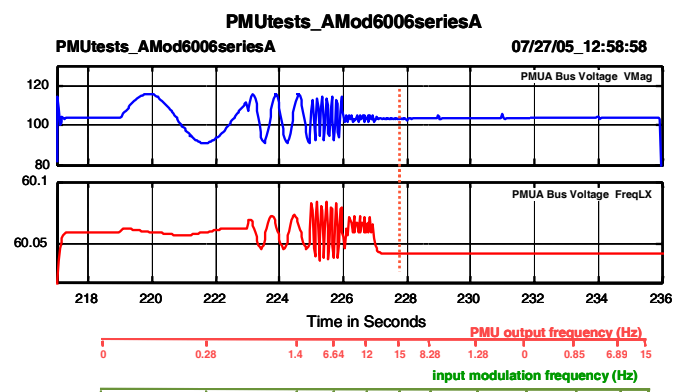

Figure 7 Interference between voltage amplitude and frequency measurement functions

#### IV. EVALUATION OF PHASOR MEASUREMENT CHANNELS

PMU hardware is very accurate as compared to standard power system instrumentation. However, application of this hardware to a practical power system is burdened by the errors introduced by the standard instrumentation channels

utilized in power systems [28]. The NASPI PSTT SynchroPhasor Accuracy Characterization document [19] provides a methodology to assess the level of inaccuracy introduced by the instrumentation channels and provides typical errors for a variety of instrumentation channel technologies.

#### A. Instrument transformers

The first link in the instrumentation channel is the instrument transformer. These devices transform power system voltages and currents to levels appropriate for driving relays, fault recorders and other monitoring equipment including PMUs. Several instrument transformer technologies are presently in use. The most common traditional technology devices are potential and current transformers (PTs and CTs), which are based on magnetic core transformer technology. Another type of commonly used voltage transducers is capacitively coupled voltage transformers (CCVTs), based on a combination of capacitive voltage dividers and magnetic core transformers. CCVTs are commonly used in high voltage applications due to economic factors. Recently, voltage and current instrument transformers have been constructed based on the electro-optical and magneto-optical phenomena. These devices are known as EOVTs (Electro-Optical Voltage Transformers) and MOCTs (Magneto-Optical Current Transformers).

Typically instrumentation channels can be classified into five distinct categories, depending on the instrument transformer used:

- CT-based instrumentation channel
- Wound-type-PT-based instrumentation channel
- CCVT-based instrumentation channel
- EOVT-based instrumentation channel
- MOCT-based instrumentation channel

Extensive testing and accuracy evaluation of instrument transformers has been reported in [29]. The most accurate instrumentation channels are current instrumentation channels that use CTs. The next most accurate instrumentation channels are voltage instrumentation channels that use wound type PTs. CCVT based instrumentation channels are relatively accurate when they are well calibrated. They perform well when the frequency is near nominal. A main drawback is that the parameters of the components shift with time and subsequently introduce large errors. In addition, during transients the error is very large because their characteristics deteriorate at frequencies other than the fundamental. Figure 8 shows the frequency response of a typical CCVT. The optical VTs and CTs are high accuracy devices for magnitude measurement but very poor for phase angle measurement. Specifically, they exhibit a time delay in the order of several tens of microseconds that translates to phase angle error in the degree range. The data directly from optical CTs and VTs are digital and should be used directly. This will eliminate the time latencies but it will require to develop new standards or adapt existing standards for data communications.

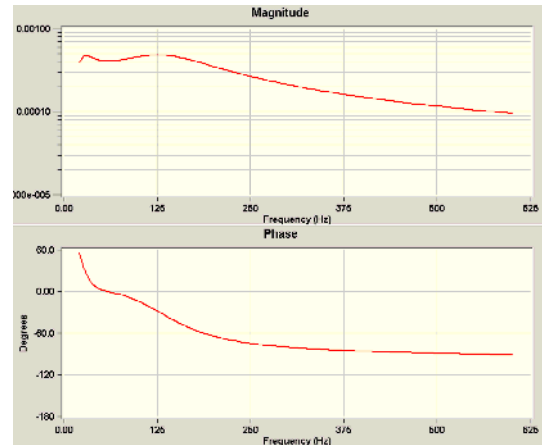

Figure 8 CCVT computed frequency response over 10-600 Hz

In all the cases, the length of the control cable is very important in determining the level of errors.

#### B. Control cables

For most of the CTs, PTs, CCVTs, etc. in substations, the associated secondary circuit wiring (significant component of the instrumentation channel) is not normally “instrumentation class” wiring. In many cases, this wiring is control type cabling (non-twisted pairs) and is often unshielded. Often changes are made to these secondary circuits that affect the overall secondary circuit burden (for example, adding or replacing relays or other devices), without a detailed engineering analysis of the impact on high accuracy applications such as the PMU installation. The use of isolating switches, the application of grounds on these secondary circuits, and the presence of non-linear burdens are a few of the factors that can have a significant impact on the accuracy of the instrumentation channel.

In one example with a CCVT based instrumentation channel, the phase error increases from 0.077 degrees with 10’ cable to 0.365 degrees with 2000’ cable as shown in Table 1.

The impact of errors introduced by instrumentation channels on phasor applications will depend on specific application requirements. Characterizing those errors and addressing their impact on applications should be an integral part of deploying a phasor measurement system.

Table 1 Phase Error (in Degrees) Versus Burden Resistance and Cable Length of a CCVT-based Instrumentation Channel

Burden Resistance	Cable Length (feet)		
	10’	1000’	2000’
50 Ohms	0.077	-0.155	-0.365
100 Ohms	0.026	-0.096	-0.213
200 Ohms	0.028	-0.063	-0.127
400 Ohms	-0.013	-0.047	-0.800
1000 Ohms	-0.022	-0.036	-0.520

## V. DISCUSSIONS

The objective of the phasor performance evaluation is to facilitate phasor deployment and applications as well as to

advance the phasor technology.

For more than a decade, PMU testing has significantly helped PMU manufacturers to identify problems and improve their products, which in turn benefit the phasor user community. This positive dialogue with manufacturers will certainly continue. Recent PMU testing results indicate phasor performance complies very well with IEEE C37.118 Standard in terms of steady state performance. Dynamic performance of phasor measurements is much better understood through PMU testing in addition to field experience over the last 15-20 years [16]. This understanding is leading to appropriate considerations in phasor applications and also leading to improvements of phasor standards.

As indicated above, phasor measurement evaluation goes beyond PMUs. Instrumentation channels are shown to have large impact on phasor quality. Being able to characterize the errors introduced by instrumentation channels enables the development of solutions to compensate the errors. The next step should continue in this direction. In most cases these errors can be accounted for and corrected via software. Two approaches are very promising: (a) model the instrumentation channel and provide model based correction algorithms, and (b) use local state estimation methods to filter out the error. From a user's perspective, instrumentation channel characterization provides guidance on equipment selection (e.g. cables), engineering design, and engineering analysis.

To ensure the good quality performance of a phasor measurement system, routine maintenance, in addition to initial evaluation, is also of significant importance. PMU settings, cable configurations, and instrument transformer characteristics may change over time and should be examined regularly. Impact of the changes should be characterized, and may be minimized or compensated in phasor measurement. Phasor performance evaluation has another layer of complexity due to the redundancy of phasor measurement systems which is needed for providing redundant phasor data for protection applications and where data validation is needed for reliable and secure performance. The PSTT team initiated an effort in developing a PMU maintenance guide based on BPA experience.

Advancement of phasor technology and applications is a collective effort of manufacturers, researchers, and users. NASPI provides an excellent forum to facilitate this ongoing collective effort.

## VI. CONCLUSION

Any given phasor measurement technique/device will meet the needs of certain applications balancing speed, accuracy, noise immunity and reporting rate requirements. But none of the techniques would meet all the requirements of existing and potential applications. Therefore, the performance of phasor measurement systems needs to be evaluated, so their impact on applications can be characterized and understood so as to provide guidelines to users of phasor measurements for specific applications.

The NASPI PSTT team has developed two important documents on this aspect: 1) PMU Testing Guide [18] and 2) SynchroPhasor Accuracy Characterization [19]. These two documents cover the phasor measurement system from instrument transformers at buses or lines to PMU hardware boxes. The first document addresses PMU testing in terms of both steady-state and dynamic performance. A set of conformance and performance test procedures are proposed with a specified set of test equipment. Performing those procedures on PMUs to be deployed will help users to assure consistent PMU system performance and support interoperability of PMUs from various vendors. The second document characterizes the errors introduced by the instrumentation channels. Typical types of instrumentation channels with a variety of instrument transformers and cables are analyzed.

In the phasor evaluation area, the NASPI PSTT also finished an installation guide [30] and are undertaking several other important activities including PMU commissioning tests, PMU maintenance guide, evaluation of multi-function phasor measurement devices, and definition and implication of "dynamic" phasors.

## VII. ACKNOWLEDGMENT

The authors gratefully acknowledge productive discussions and contributions within the NASPI Performance and Standard Task Team that have led to the developments of many user application reference documents and technological developments. Z. Huang would like to extend special thanks to Dr. John Hauer at PNNL for his mentoring and encouragement over the years on the subject of wide-area measurement.

## VIII. REFERENCES

- The NASPI PSTT documents are available at <http://www.naspi.org/resources/pstt/psttresources.stm>.
  - WECC documents cited here are available at <ftp.bpa.gov/pub/WAMS%20Information/>, <http://www.wecc.biz/committees/JGC/DMWG/documents/>, or by special request to the authors.
- [1] G. Missout, P. Girard, "Measurement of Bus Voltage Angle between Montreal and Sept-Iles", IEEE Transactions on Power Apparatus and Systems, pp. 536-539, March/April 1980.
  - [2] P. Bonanomi, "Phase Angle Measurements with Synchronized Clocks", IEEE Transactions on Power Apparatus and Systems, Vol. PAS-100, No. 12, pp 5036-5043, December 1981.
  - [3] Phadke, A.G., J.S. Thorp, and M.G. Adamiak. 1983. "A New Measurement Technique for Tracking Voltage Phasors, Local System Frequency, and Rate of Change of Frequency". IEEE Transactions on Power Apparatus and Systems. PAS-102(5):1025-1038.
  - [4] "Synchronized Phasor measurements for the WSCC", EPRI Report TR-107908-3717-01, Principal Investigators: A.G.Phadke and J.S. Thorp, May 1997.
  - [5] J. F. Hauer, W. A. Mittelstadt, J W. Burns, K. E. Martin, Harry Lee, and D. J. Trudnowski. Use of the WECC WAMS in Staged System Tests for Validation of System Performance and Modeling: Summary Report for

- September 2005–August 2006. Interim report of the WECC Disturbance Monitoring Work Group, April 25, 2007.
- [6] J.F. Hauer, and J.G. DeSteele, “Descriptive Model of a Generic WAMS”, PNNL Report PNNL-17138, Prepared for U.S. Department of Energy Office of Electricity Delivery and Energy Reliability, June 2007.
- [7] J. F. Hauer, W. A. Mittelstadt, W. H. Litzenberger, C. Clemens, D. Hamai, and P. N. Overholt. “Wide Area Measurements for Real-Time Control and Operation of Large Electric Power Systems – Evaluation and Demonstration of Technology for The New Power System”. Prepared for U.S. Department of Energy Under BPA Contracts X5432-1, X9876-2; January 1999.
- [8] J.F. Hauer, F. J. Hughes, D. Trudnowski, G. Rogers, J. Pierre, L. Scharf, and W. Litzenberger. “Dynamic Information Manager for Networked Monitoring of Large Power Systems”. EPRI Report TR-112031, May 1999. Selected portions of this report and associated attachments are available from BPA and PNNL.
- [9] D. N. Kosterev, C. W. Taylor, and W. A. Mittelstadt, “Model Validation for the August 10, 1996 WSCC System Outage,” *IEEE Trans. Power Syst.*, vol. 14, no. 3, pp. 967-979, August 1999.
- [10] B. Fardanesh, S. Zelingher, A. P. Sakis Meliopoulos, G. Cokkinides and Jim Ingleson, “Multifunctional Synchronized Measurement Network”, *IEEE Computer Applications in Power*, Volume 11, Number 1, pp 26-30, January 1998.
- [11] U.S.-Canada Power System Outage Task Force, “Final Report on the August 14, 2003 Blackout in the United State and Canada: Causes and Recommendations”, April 2004. Available at <https://reports.energy.gov/>
- [12] Vahid Madani, Western Interconnection Experience With Phasor Measurements, IEEE Power Engineering Society Power System Conference and Exhibition, 2006.
- [13] D. Novosel, V. Madani, B. Bhargava, K. Vu, and J. Cole, “Dawn of the Grid Synchronization,” *IEEE Power and Energy Magazine*, Vol. 6, pp. 49-60, January/February 2008.
- [14] Liang Zhao; Abur, A., Multi area state estimation using synchronized phasor measurements,” *IEEE Transactions on Power Systems*, Volume 20, Issue 2, May 2005 Page(s):611 – 617.
- [15] Hauer, J.F., Application of Prony analysis to the determination of modal content and equivalent models for measured power system response,” *IEEE Transactions on Power Systems*, Volume 6, Issue 3, Aug. 1991 Page(s):1062 – 1068.
- [16] J. F. Hauer, K. Martin, and H. Lee, “Evaluating the Dynamic Performance of Phasor Measurement Units: Experience in the Western Power System”, Interim Report of the WECC Disturbance Monitoring Work Group, August 2005.
- [17] IEEE Standard for Synchrophasors for Power Systems, IEEE Standard C37.118-2005, March 2006.
- [18] “PMU System Testing and Calibration Guide,” Technical Report for the North American SynchroPhasor Initiative, Performance and Standard Task Team, team leader G. Stenbakken, December 2007.
- [19] “SynchroPhasor Measurement Accuracy Characterization”, Technical Report for the North American SynchroPhasor Initiative, Performance and Standard Task Team, team leader S. Meliopoulos, December 2007.
- [20] Zhenyu Huang, John F. Hauer, and Kenneth E. Martin, “Evaluation of PMU Dynamic Performance in Both Lab Environments and under Field Operating Conditions,” in: Proceedings of the IEEE Power Engineering Society General Meeting 2007, Tampa, FL, USA, June 24–28, 2007.
- [21] G. Stenbakken, and T. Nelson, “Static Calibration and Dynamic Characterization of PMUs at NIST,” *Power Engineering Society General Meeting*, 2007. IEEE, 24-28 June 2007.
- [22] J. Depablos, V. Centeno, A.G. Phadke, and M. Ingram, “Comparative testing of synchronized phasor measurement units,” *Power Engineering Society General Meeting*, 2004. IEEE, 6-10 June 2004.
- [23] A.P.S. Meliopoulos, G.J. Cokkinides, O. Wasynczuk, E. Coyle, M. Bell, C. Hoffmann, C. Nita-Rotaru, T. Downar, L. Tsoukalas, and R. Gao, “PMU data characterization and application to stability monitoring,” *Power Engineering Society General Meeting*, 2006. IEEE. 18-22 June 2006.
- [24] J. F. Hauer, W. A. Mittelstadt, K. E. Martin, J. W. Burns, and Harry Lee in association with the Disturbance Monitoring Work Group of the Western Electricity Coordinating Council. Integrated Dynamic Information for the Western Power System: WAMS Analysis in 2005. Chapter 14 in the Power System Stability and Control volume of *The Electric Power Engineering Handbook*, edition 2, L. L. Grigsby ed., CRC Press, Boca Raton, FL, 2007.
- [25] Zhenyu Huang, Tony Faris, et al. Laboratory Performance Evaluation Report of SEL 421 Phasor Measurement Unit (PMU), PNNL Technical Report PNNL-16852, November 2007.
- [26] G.N. Stenbakken, M. Zhou, “Dynamic Phasor Measurement Unit Test System,” *IEEE Power Engineering Society General Meeting 2007*, 24-28 June 2007.
- [27] G.N. Stenbakken, T.L. Nelson, M. Zhou, and V. Centeno, “Reference Values for Dynamic Calibration of PMUs,” *Proceedings of the 41st Hawaii International Conference on System Sciences (HICSS-41)*, IEEE Computer Society, January 2008.
- [28] A. P. Sakis Meliopoulos and G. J. Cokkinides, “Visualization and Animation of Instrumentation Channel Effects on DFR Data Accuracy”, *Proceedings of the 2002 Georgia Tech Fault and Disturbance Analysis Conference*, Atlanta, Georgia, April 29-30, 2002.
- [29] A. P. Meliopoulos, F. Zhang, S. Zelingher, G. Stillmam, G. J. Cokkinides, L. Coffeen, R. Burnett, J. McBride, “Transmission Level Instrument Transformers and Transient Event Recorders Characterization for Harmonic Measurements,” *IEEE Transactions on Power Delivery*, Vol. 8, No. 3, pp 1507-1517, July 1993.
- [30] A Guide for PMU Installation, Commissioning and Maintenance, Part II: PMU Installation procedures”, Technical Report for the North American SynchroPhasor Initiative, Performance and Standard Task Team, team leader K. Martin,, June 2007.