

# Performance of Turbo-SISO, Turbo-SIMO, Turbo-MISO and Turbo-MIMO system using STBC

M.M.Kamruzzaman and Li Hao

Key Lab of Information Coding & Transmission  
Southwest Jiaotong University  
Chengdu, Sichuan, China  
E-mail: m.m.kamruzzaman@gmail.com

**Abstract**— In this paper, performance of a Turbo coded wireless link is evaluated in the presence of Rayleigh fading for single-input single-output (SISO), single-input multiple-output(SIMO), multiple-input single-output (MISO) and multiple-input multiple-output (MIMO) system. Turbo encoded and 64-ary Quadrature Amplitude Modulation (QAM) modulated data are further encoded using space-time block coding (STBC) and then split into  $n$  streams which are simultaneously transmitted through single transmit antenna for Turbo-SIMO system and  $n$  transmit antennas for Turbo-MISO and Turbo-MIMO system. Simulation results obtained show that the Turbo-SISO system provides 45 dB coding gain, Turbo-SIMO system provides 27,20 and 17 dB coding gain for 2,3 and 4 receive antenna respectively, Turbo-MISO system provides 26, 19 and 15 dB coding gain for 2,3 and 4 transmit antenna respectively, Turbo-MIMO system provides 12 to 17 dB coding gain for different combination of transmit and receive antennas at a BER of  $10^{-6}$  compared to uncoded SISO, SIMO, MISO and MIMO system.

**Index Terms**— diversity, SISO, SIMO, MISO, MIMO, space time block code, turbo code, rayleigh fading, wireless communication.

## I. INTRODUCTION

The increasing demand for high data rates in wireless communications due to emerging new technologies makes wireless communications an exciting and challenging field. Forward error correction (FEC) coding schemes are used in most of the digital communication systems. Turbo codes are a class of high-performance FEC codes which were the first practical codes to closely approach the channel for the single-in, single-out (SISO) system capacity [1-13]. So they are specified as FEC schemes for most of the future wireless systems. An orthogonal space time block coding schemes for two

transmit antennas was first reported by Alamouti with code rate one [14]. Tarokh proposed a space-time block coding (STBC) scheme for more than two transmit antennas with the rate less than one [15]. Space Time Block coding have advantages of both the spatial diversity provided by multiple antennas and the temporal diversity available with time-varying fading. However, only space-time codes can't satisfy the reliability requirement in future mobile systems[14-19], so space-time codes should be concatenated with channel coding to provide more coding gains.

A combination of the space-time coding and the turbo coding referred to as the space-time turbo coding has been widely studied. Much attention has been paid to improve the link performance of multiple-input multiple-output (MIMO) system [20-30]. This paper presents a study on combination of the space-time coding and the turbo coding for SISO, single-input multiple-output(SIMO), multiple-input single-output (MISO) and MIMO system for different number of transmit and receive antennas with the concept of Alamouti's two transmit antennas of code rate one and Tarokh's three and four transmit antennas with code rate  $\frac{3}{4}$ . And our scheme performs better than earlier proposed schemes.

## II. SYSTEM MODEL

Researchers consider a system where transmitter and receiver are equipped with  $n$  and  $m$  antennas respectively (for Turbo-SIMO system  $n=1$ , Turbo-SIMO system  $n=1$  and Turbo-MISO system  $m=1$ ). Data are encoded by a turbo encoder, the encoded bits are modulated by a 64 QAM modulator and the modulated symbols are mapped using STBC. So at each time slot  $t$ , signals  $c_t^i$ ,  $i=1, 2, \dots, n$  are transmitted simultaneously using  $n$  transmit antennas. The channel is assumed to be a flat fading channel and the path gain from transmit antenna  $i$  to receive antenna  $j$  is defined to be  $\alpha_{i,j}$ . The path gains are modeled as samples of independent complex Gaussian random variables with variance 0.5 per real dimension. The wireless channel is assumed to be quasi-static so that

Manuscript received September 19, 2011; accepted September 30, 2011. This work was supported by the Key Project of Chinese Ministry of Education (No.108179).

M.M.Kamruzzaman & Li Hao are with the Key Lab of Information Coding & Transmission, Southwest Jiaotong University, Chengdu, Sichuan, China. E-mail: [m.m.kamruzzaman@gmail.com](mailto:m.m.kamruzzaman@gmail.com) & [lhao@swjtu.home.edu.cn](mailto:lhao@swjtu.home.edu.cn)

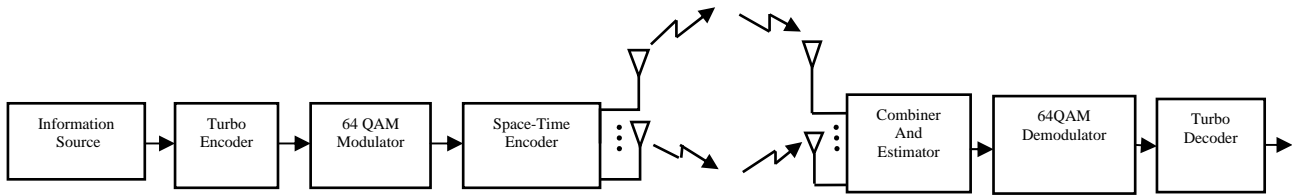

Fig 1. System block diagram

the path gains are constant over a frame of length  $l$  and vary from one frame to another. At time  $t$  the signal  $r_t^j$ , received at antenna  $j$ , is given by

$$r_t^j = \sum_{i=1}^n \alpha_{i,j} c_t^i + \eta_t^j \tag{1}$$

where the noise samples are independent samples of a zero-mean complex Gaussian random variable with variance  $n/(2SNR)$  per complex dimension. The average energy of the symbols transmitted from each antenna is normalized to be one. Assuming perfect channel state information is available; the receiver computes the decision metric

$$\sum_{t=1}^l \sum_{j=1}^m \left| r_t^j - \sum_{i=1}^n \alpha_{i,j} c_t^i \right|^2 \tag{2}$$

over all code words

$$c_1^1 c_1^2 \dots c_1^n c_2^1 c_2^2 \dots c_2^n \dots c_l^1 c_l^2 \dots c_l^n$$

and decides in favor of the code word that minimizes the sum[15].

A. Encoding

The information source is encoded by a binary turbo encoder. The turbo encoder consists of two relatively simple recursive systematic convolutional (RSC) encoders, concatenated in parallel via a pseudorandom (turbo) interleaver [1-3]. The information bits are encoded by both RSC encoders. The first RSC encoder operates on the input bits in their original order, while the second RSC encoder operates on the input bits as permuted by the Turbo interleaver. If the input symbol is of length 1 and output symbol size is R, then the encoder is of code rate  $r_c=1/R$ . The interleaver size and structure of turbo code affect the code error performance considerably; no attempt was made to optimize their design of turbo code. Fig. 2 shows the block diagram of a turbo encoder of rate 1/3. In the diagram  $b_k^s$  is the systematic bits, and  $b_k^{p1}$ , and  $b_k^{p2}$  are the parity check bits. The 64 QAM

number of transmit antennas as shown in Table I, Table II and Table III.

B. Decoding

The combiner combines received signals which are then sent to the maximum likelihood detector. For detecting symbols of two transmit antennas (3) and (4) decision metrics have been used [15]:

To detect symbol  $s_1$ , (3) is used.

$$\left[ \sum_{j=1}^m (r_1^j \alpha_{1,j}^* + (r_2^j)^* \alpha_{2,j}) - s_1 \right]^2 + \left( -1 + \sum_{j=1}^m \sum_{i=1}^2 |\alpha_{i,j}|^2 \right) |s_1|^2 \tag{3}$$

To detect symbol  $s_2$ , (4) is used.

$$\left[ \sum_{j=1}^m (r_1^j \alpha_{2,j}^* - (r_2^j)^* \alpha_{1,j}) - s_2 \right]^2 + \left( -1 + \sum_{j=1}^m \sum_{i=1}^2 |\alpha_{i,j}|^2 \right) |s_1|^2 \tag{4}$$

For detecting symbols of three transmit antennas (5),(6) and (7) decision metrics have been used [15]:

To detect symbol  $s_1$ , (5) is used.

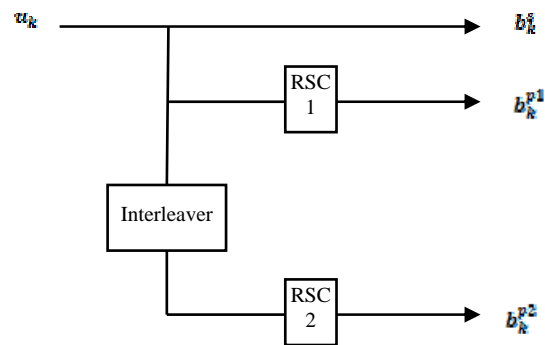

Fig. 2. Structure of Turbo Encoder

TABLE I  
THE ENCODING AND TRANSMISSION SEQUENCE FOR TWO TRANSMIT ANTENNAS OF ALAMOUTI WITH CODE RATE ONE [14].

| Time Slot    | Antenna   |            |
|--------------|-----------|------------|
|              | Antenna-I | Antenna-II |
| Time slot-I  | $x_1$     | $x_2$      |
| Time slot-II | $-x_2^*$  | $x_1^*$    |

modulator modulates the turbo encoded bits. STBC encoder encodes the modulated symbols according to

$$\left[ \sum_{j=1}^m \left( r_1^j \alpha_{1,j}^* + (r_2^j)^* \alpha_{2,j} + \frac{(r_4^j - r_3^j) \alpha_{3,j}^*}{2} - \frac{(r_3^j + r_4^j)^* \alpha_{3,j}}{2} \right) \right] - s_1 \left| + \left( -1 + \sum_{j=1}^m \sum_{i=1}^3 |\alpha_{i,j}|^2 \right) \right| s_1 \right|^2 \tag{5}$$

To detect symbol s2, (6) is used.

$$\left[ \sum_{j=1}^m \left( r_1^j \alpha_{2,j}^* - (r_2^j)^* \alpha_{1,j} + \frac{(r_4^j - r_3^j) \alpha_{3,j}^*}{2} - \frac{(-r_3^j + r_4^j)^* \alpha_{3,j}}{2} \right) \right] - s_2 \left| + \left( -1 + \sum_{j=1}^m \sum_{i=1}^3 |\alpha_{i,j}|^2 \right) \right| s_2 \right|^2 \tag{6}$$

To detect symbol s3, (7) is used.

$$\left[ \sum_{j=1}^m \left( \frac{(r_1^j + r_2^j) \alpha_{3,j}^*}{\sqrt{2}} + \frac{(r_3^j)^* (\alpha_{1,j} + \alpha_{2,j})}{\sqrt{2}} + \frac{(r_4^j)^* (\alpha_{1,j} - \alpha_{2,j})}{\sqrt{2}} \right) \right] - s_3 \left| + \left( -1 + \sum_{j=1}^m \sum_{i=1}^3 |\alpha_{i,j}|^2 \right) \right| s_3 \right|^2$$

For detecting symbols of four transmit antennas (8), (9) and (10) decision metrics have been used [15]:

To detect symbol s1, (8) is used.

$$\left[ \sum_{j=1}^m \left( r_1^j \alpha_{1,j}^* + (r_2^j)^* \alpha_{2,j} + \frac{(r_4^j - r_3^j) (\alpha_{3,j}^* - \alpha_{4,j}^*)}{2} - \frac{(r_3^j + r_4^j)^* (\alpha_{3,j} - \alpha_{4,j})}{2} \right) \right] - s_1 \left| + \left( -1 + \sum_{j=1}^m \sum_{i=1}^4 |\alpha_{i,j}|^2 \right) \right| s_1 \right|^2 \tag{8}$$

To detect symbol s2, (9) is used.

$$\left[ \sum_{j=1}^m \left( r_1^j \alpha_{2,j}^* + (r_2^j)^* \alpha_{1,j} + \frac{(r_4^j + r_3^j) (\alpha_{3,j}^* - \alpha_{4,j}^*)}{2} + \frac{(-r_3^j + r_4^j)^* (\alpha_{3,j} - \alpha_{4,j})}{2} \right) \right] - s_1 \left| + \left( -1 + \sum_{j=1}^m \sum_{i=1}^4 |\alpha_{i,j}|^2 \right) \right| s_1 \right|^2 \tag{9}$$

TABLE II  
THE ENCODING AND TRANSMISSION SEQUENCE FOR THREE TRANSMIT ANTENNAS OF TAROKH WITH CODE RATE 3/4 [15].

| Time slot     | Antenna                  |                           |  |
|---------------|--------------------------|---------------------------|--|
|               | Antenna-I                | Antenna-II                | Antenna-III                            |
| Time slot-I   | $x_1$                    | $x_2$                     | $\frac{x_3}{\sqrt{2}}$                 |
| Time slot-II  | $-x_2^*$                 | $x_1^*$                   | $\frac{x_3}{\sqrt{2}}$                 |
| Time slot-III | $\frac{x_3^*}{\sqrt{2}}$ | $\frac{x_3^*}{\sqrt{2}}$  | $\frac{-x_1 - x_1^* + x_2 - x_2^*}{2}$ |
| Time slot-IV  | $\frac{x_3^*}{\sqrt{2}}$ | $-\frac{x_3^*}{\sqrt{2}}$ | $\frac{x_2 + x_2^* + x_1 - x_1^*}{2}$  |

TABLE III  
THE ENCODING AND TRANSMISSION SEQUENCE FOR FOUR TRANSMIT ANTENNAS OF TAROKH WITH CODE RATE 3/4 [15]

| Time slot     | Antenna                  |                           |  |  |
|---------------|--------------------------|---------------------------|--|--|
|               | Antenna-I                | Antenna-II                | Antenna-III                            | Antenna-IV                             |
| Time slot-I   | $x_1$                    | $x_2$                     | $\frac{x_3}{\sqrt{2}}$                 | $\frac{x_3}{\sqrt{2}}$                 |
| Time slot-II  | $-x_2^*$                 | $x_1^*$                   | $\frac{x_3}{\sqrt{2}}$                 | $-\frac{x_3}{\sqrt{2}}$                |
| Time slot-III | $\frac{x_3^*}{\sqrt{2}}$ | $\frac{x_3^*}{\sqrt{2}}$  | $\frac{-x_1 - x_1^* + x_2 - x_2^*}{2}$ | $\frac{-x_1 - x_2^* + x_1 - x_1^*}{2}$ |
| Time slot-IV  | $\frac{x_3^*}{\sqrt{2}}$ | $-\frac{x_3^*}{\sqrt{2}}$ | $\frac{x_2 + x_2^* + x_1 - x_1^*}{2}$  | $\frac{x_1 + x_1^* + x_2 - x_2^*}{2}$  |

To detect symbol  $s_3$ , (10) is used.

$$\left[ \sum_{j=1}^m \left( \frac{(r_1^j + r_2^j) \alpha_{3,j}^*}{\sqrt{2}} + \frac{(r_1^j - r_2^j) \alpha_{4,j}^*}{\sqrt{2}} + \frac{(r_3^j) (\alpha_{1,j} + \alpha_{2,j})}{\sqrt{2}} + \frac{(r_4^j) (\alpha_{1,j} - \alpha_{2,j})}{\sqrt{2}} \right) \right] - s_3 \left[ -1 + \sum_{j=1}^m \sum_{i=1}^4 |\alpha_{i,j}|^2 \right] |s_3|^2 \quad (10)$$

The detected symbols are demodulated by 64QAM demodulator and send to turbo decoder to get the output. The turbo decoding is performed by a suboptimal iterative algorithm. The decoder consists of two identical concatenated decoders of the component codes separated by the same interleaver as shown in Fig. 3. The component decoders are based on a maximum a posteriori (MAP) algorithm or a soft output Viterbi algorithm (SOVA) generating a weighted soft estimate of the input sequence. However researchers used the MAP decoder to decode the Turbo code [1-3]. If data  $u = i$  is transmitted from a set of  $M$  different signal and turbo decoder receives signal  $M$ , then the a posteriori probability (APP) of a decision on  $u = i$  given by expressed

$$P(u = i | y) = \frac{p(y | u = i)P(u = i)}{p(y)}, i = 1, \dots, M \quad (11)$$

and

$$p(y) = \sum_{i=1}^M p(y | u = i)P(u = i) \quad (12)$$

where

$P(u = i | y)$  is the APP,  $P(y | u = i)$  is the probability density function(pdf) of the received signal  $y$  given that signal set is transmitted (a propri probability), and  $p(y)$  is the pdf of the received signal.  $P(y)$  is a scaling factor for each specific observation. It can be shown using Bayes' decision rule that the optimum decision that minimizes the probability of error in detection of the signal is the decion on maximum a posteriori probability (MAP) which may be expressed as

$$u = i \text{ iff } P(u = i | y) > P(u = k | y), \quad \forall k = 0, \dots, M, k \neq i \quad (13)$$

From (11), the APP's in (13) can be replaced by the following equivalent expressions canceling common term,  $p(y)$  from both sides:

$$u = i \text{ iff } p(y | u = i)P(u = i | y) > p(y | u = k)P(u = k), \quad \forall k = \{0, \dots, M\}, k \neq i \quad (14)$$

Let the binary data, 0 and 1, be represent by -1 and +1 respectively. Then the equation (13) and (14) can be written as:

$$P(u = +1 | y) \underset{H_2}{\overset{H_1}{\gtrless}} P(u = -1 | y) \quad (15)$$

and

$$p(y | u = +1)P(u = +1 | y) \underset{H_2}{\overset{H_1}{\gtrless}} p(y | u = -1)P(u = -1 | y) \quad (16)$$

which means that one should decide in favor of hypothesis  $H_1, u = +1$ , if the left hand side of equation (16) is greater than the right hand side. Otherwise one should choose hypothesis  $H_2, u = -1$ . Equation (15) and (16) can be written in a ratio format to give the likelihood ratio test:

$$\frac{P(u = +1 | y)}{P(u = -1 | y)} \underset{H_2}{\overset{H_1}{\gtrless}} 1 \quad (17)$$

and

$$\frac{p(y | u = +1)P(u = +1)}{p(y | u = -1)P(u = -1)} \underset{H_2}{\overset{H_1}{\gtrless}} 1 \quad (18)$$

By taking the logarithm of the likelihood ratio, the posteriori log likelihood ratio is obtained as

$$L(u | y) = \log \left( \frac{P(u = +1 | y)}{P(u = -1 | y)} \right) \quad (19)$$

The MAP decoding rule can now be translated to

$$\hat{u} = \text{sign}[L(u | y)] \quad (20)$$

where  $\hat{u}$  is the detected signal.

### III. SIMULATION RESULTS

In this section, computer simulation is carried out to show the BER performance of the proposed system. The results are evaluated for several combinations of  $T_x$  and  $R_x$  antennas with and without Turbo coding. For the uncoded system (without turbo code), researchers used only STBC. For two transmit antennas, researchers used Alamouti's code with code rate one. And for three and four transmit antennas, researchers used Tarokh's code

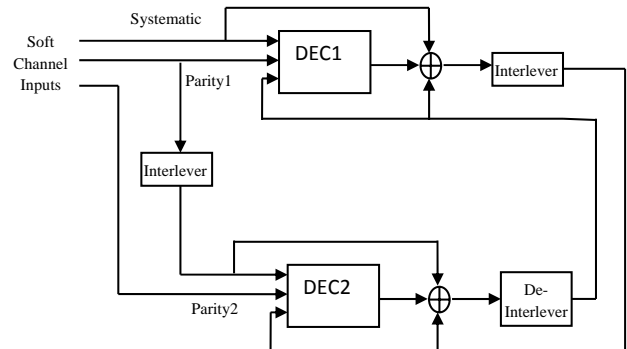

Fig. 3. Block diagram of turbo decoder

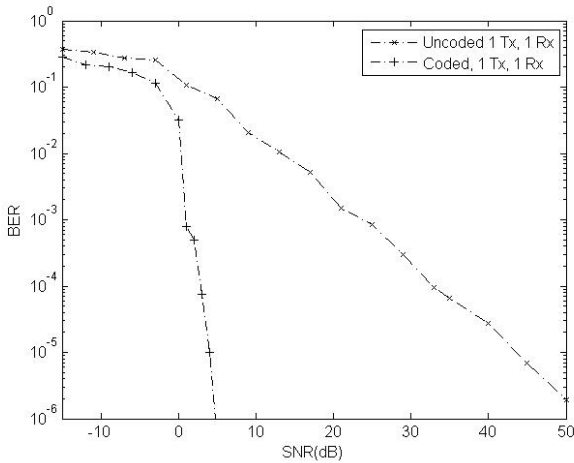

Fig. 4. BER performance comparison of Turbo-SISO system and uncoded SISO system.

with code rate  $\frac{3}{4}$ . Turbo code with frame size= 378, rate=  $\frac{1}{3}$ , encoder generator  $g = [1\ 0\ 1\ 1; 1\ 1\ 0\ 1; 1\ 1\ 1\ 1]$  and number of iterations =2 is considered to perform simulation. Researchers present the BERs to compare the performance of Turbo-SISO system with uncoded SISO in Fig. 4 Researchers observe that the Turbo-SISO system provides 47 dB coding gain compared to uncoded SISO at a BER of  $10^{-6}$ .

Fig. 5 shows the performance of Turbo-SIMO system. Turbo-SIMO system with one  $T_x$  antenna provides 27,20 and 17 dB coding gain for 2, 3 and 4  $R_x$  antenna respectively, at a BER of  $10^{-6}$  compared to uncoded SIMO system. The coding gain is found to be 5 dB, 7dB and 9 dB at BER  $10^{-6}$  of a Turbo-SIMO system with 2,3 and 4  $R_x$  antenna respectively compared to Turbo-SISO system. And there is around 2.5 dB gain for increasing  $R_x$  antenna from 2 to 3 and 3 to 4 of Turbo-SIMO system

Fig. 6 shows the performance of Turbo-MISO system. Turbo-MISO system with one  $R_x$  antenna provides 26, 19 and 15 dB coding gain for 2, 3 and 4 transmit antenna respectively at BER of  $10^{-6}$  compared to uncoded MISO

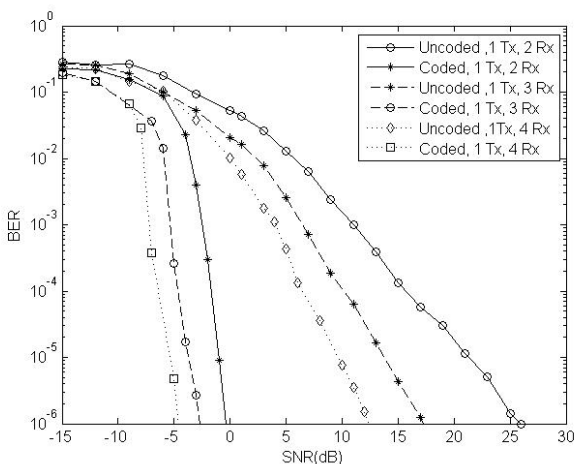

Fig. 5. BER performance comparison of Turbo-SIMO system and uncoded MISO system.

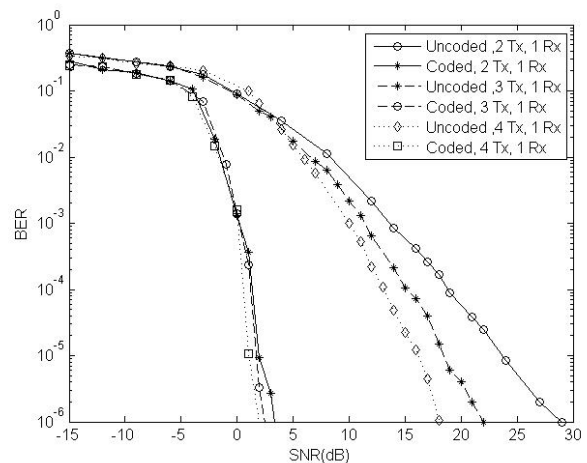

Fig. 6. BER performance comparison of Turbo-MISO system and uncoded MISO system.

system. And there is around 0.5 dB gain for increasing  $T_x$  antenna from 2 to 3 and 3 to 4 of Turbo-SIMO system.

Fig. 7 shows the performance of Turbo-MIMO system with two  $T_x$  antenna. It provides 16.5, 14.5 and 13 dB coding gain for 2,3 and 4  $R_x$  antenna respectively at BER of  $10^{-6}$  compared to uncoded MIMO system with same diversity. And there is around 2-3 dB gain for increasing  $R_x$  antenna from 2 to 3 and 3 to 4 of Turbo-MIMO system with 2  $T_x$ .

Fig. 8 shows the performance of Turbo-MIMO system with three  $T_x$  antennas. It provides 14, 12 and 12 dB coding gain for 2,3 and 4  $R_x$  antenna respectively at a BER of  $10^{-6}$  compared to uncoded MIMO system with same diversity. And there is around 1.5-2 dB gain for increasing  $R_x$  antenna from 2 to 3 and 3 to 4 of Turbo-MIMO system with 3  $T_x$ .

Fig. 9 shows the performance of Turbo-MIMO system with four  $T_x$  antennas. It provides 12, 12 and 11.5 dB coding gain for 2,3 and 4  $R_x$  antenna respectively at a BER of  $10^{-6}$  compared to uncoded MIMO system with same diversity. And there is around 1.5-2 dB gain for increasing  $R_x$  antenna from 2 to 3 and 3 to 4 of Turbo-

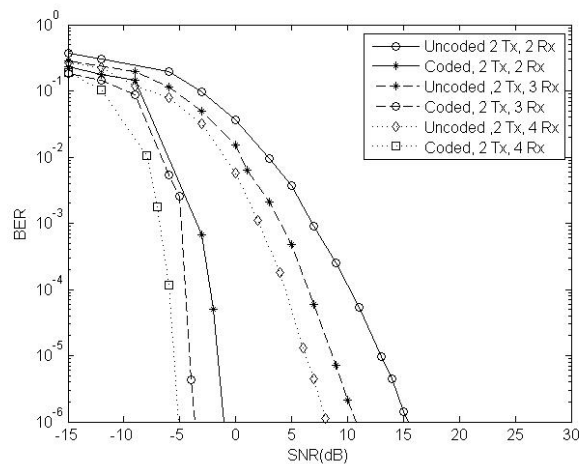

Fig. 7. BER performance comparison of Turbo-MIMO system (2 $T_x$  & 2/3/4  $R_x$ ) and uncoded MIMO system with same diversity.

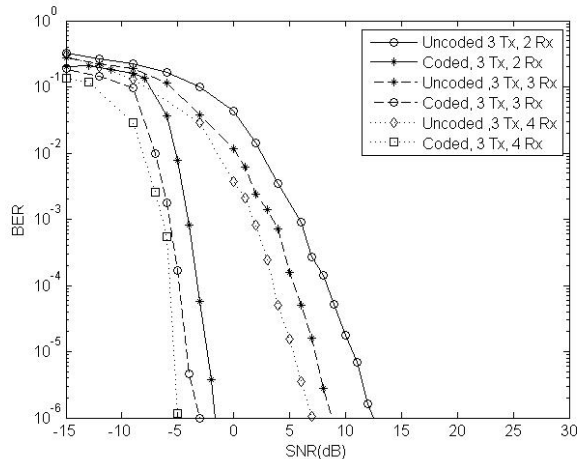

Fig. 8. BER performance comparison of Turbo-MIMO system ( $3T_x$  &  $2/3/4 R_x$ ) and uncoded MIMO system with same diversity

MIMO system with  $4 T_x$

#### IV. CONCLUSION

The simulation results show that our scheme outperforms earlier proposed schemes and Turbo code makes a significant difference for Turbo-SISO, Turbo-SIMO, Turbo-MISO and Turbo-MIMO system.

#### ACKNOWLEDGMENT

This work was supported by the Key Project of Chinese Ministry of Education (No.108179).

#### REFERENCES

- [1] C. Berrou, A. Glavieux and P. Thitimajshima, "Near Shannon limit error-correcting coding and decoding: Turbo-codes (1)," ICC'93. 1993: 1064-1074P
- [2] C. Berrou and A. Glavieux. "Near optimum error correcting coding and decoding: Turbo-codes," IEEE Trans. Commun., vol. 44, no. 10, Oct., 1996: 1261-1271P
- [3] C. Berrou and A. Glavieux. Reflections on the prize paper: "Near optimum error correcting coding and decoding: turbo-codes," IEEE Inform. Theory Society Newsletter, vol. 48, no. 2, June, 1998: 23-31P
- [4] P. Robertson, "Illuminating the structure of code and decoder of parallel concatenated recursive systematic (turbo) codes," In Proc. IEEE Global Communications Conference, pp. 1298-1303, 1994.
- [5] S. Benedetto and G. Montorsi, "Unveiling turbo codes: some results on parallel concatenated schemes," IEEE Trans. Inform. Theory, vol. 42, no. 2, pp. 409-428, Mar. 1996.
- [6] T. M. Duman and M. Salehi, "Performance bounds for turbo coded modulation systems," IEEE Trans. Commun., vol. 47, no. 4, pp. 511-521, Apr. 1999.
- [7] I. Sason and S. Shamai (Shits), "Improved upper bounds on the ml decoding error probability of parallel and serial concatenated turbo codes via their ensemble distance spectrum," IEEE Tran. Inform. Theory, vol. 46, no. 1, pp. 24-47, Jan. 2000.
- [8] S. Benedetto, D. Divsalar, G. Montorsi, and F. Pollara, "Serial concatenation of interleaved codes: performance analysis, design, and iterative decoding," IEEE Tran. Inform. Theory, vol. 44, no. 3, pp. 909-926, May 1998.

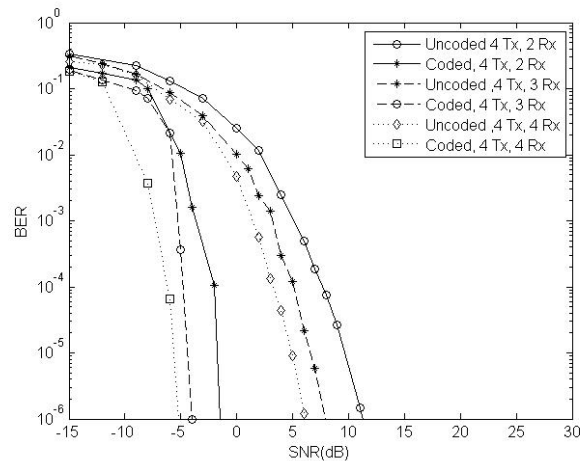

Fig. 9. BER performance comparison of Turbo-MIMO ( $4T_x$  &  $2/3/4 R_x$ ) and uncoded MIMO system with same diversity

- [9] K. Narayanan and G. L. Stuber, "A serial concatenation approach to iterative demodulation and decoding," IEEE Trans. Commun., vol. 47, no. 7, pp. 956-961, Jul. 1999.
- [10] G. Ungerboeck, "channel coding with multilevel/phase signals," IEEE Tran. Inform. Theory, pp. 784{791, Nov. 1984.
- [11] S. Le Goff, A. Glavieux, and C. Berrou, "Turbo codes and high spectral efficiency modulation," In Proc. IEEE International Conference on Communications-Supercomm-ICC'94, pp. 645-649, New Orleans, May 1994.
- [12] P. Robertson and T. Woerz, "Coded modulation scheme employing turbo codes," Electronic letters, vol. 31, no. 18, pp. 1546-1547, Aug. 1995.
- [13] P. Robertson and T. Woerz, "A novel bandwidth efficient coding scheme employing turbo codes," In Proc. ICC'96, pp. 962-967, June 1996.
- [14] S.M. Alamouti, "A simple transmit diversity scheme for wireless communications," IEEE J. Select. Areas Commun., vol. 16, no. 8, pp. 1451-1458, Oct. 1998.
- [15] Vahid Tarokh, Hamid Jafarkhani, and A. Robert Calderbank, "Space-time block coding for wireless communications: performance results," IEEE J. Select. Areas Commun., vol. 17, pp. 451-460, Mar. 1999.
- [16] Vahid Tarokh and Hamid Jafarkhani, "A differential detection scheme for transmit diversity," IEEE journal on selected areas in communications, vol. 18, no. 7, July 2000
- [17] V. Tarokh, H. Jafarkhani, and A. R. Calderbank, "Space-time block codes from orthogonal designs," IEEE Trans. Inform. Theory, vol. 45, pp. 1456-1466, July 1999.
- [18] V. Tarokh, A. Naguib, N. Seshadri, and A. R. Calderbank, "Combined array processing and space-time coding," IEEE Trans. Inform. Theory, vol. 45, pp. 1121-1128, May 1999.
- [19] Vahid Tarokh, Nambi Seshadri and A. R. Calderbank, "Space-time codes for high data rate wireless communication: performance criterion and code construction," IEEE Trans. Inform. Theory, vol. 44, no. 2, March 1998
- [20] A. Stefanov and T. M. Duman, "Turbo-coded modulation for systems with transmit and receive antenna diversity over block fading channels: system model, decoding approaches, and practical considerations," IEEE journal on selected areas in communications, vol. 19, no. 5, May 2001
- [21] Christian Schlegel and Alex Grant, "Differential space-time turbo codes," IEEE Trans. Inform. Theory, vol. 49, no. 9, September 2003
- [22] Ezio Biglieri, Alessandro Nardio, Giorgio Taricco, "Doubly iterative decoding of space-time turbo codes with a large number of antennas," IEEE Trans. on Commun., vol. 53, no. 5, May 2005

- [23] Gerhard Bauch and Naofal Al-Dhahir, "Reduced-complexity space-time turbo-equalization for frequency-selective mimo channels," IEEE Trans. on Commun., vol. 1, no. 4, October 2002
- [24] Hsuan-Jung Su and Evaggelos Geraniotis, "Space-time turbo codes with full antenna diversity," IEEE Trans. on Commun., vol. 49, no. 1, January 2001
- [25] Youjian Liu, Michael P. Fitzand Oscar Y. Takeshita, "Full Rate Space-Time Turbo Codes," IEEE journal on selected areas in communications, vol. 19, no. 5, May 2001.
- [26] Israfil Bahceci and Tolga M. Duman, "Combined turbo coding and unitary space-time modulation," IEEE Trans. on Commun., vol. 50, no. 8, August 2002.
- [27] Yinggang Du Kam Tai Chan "Enhanced space-time block coded systems by concatenating turbo product codes" Communications Letters, IEEE, Volume: 8, Issue: 6 On page(s): 388 – 390 June 2004
- [28] Yi Hong, Jinhong Yuan, Zhuo Chen and Branka Vucetic, "Space-time turbo trellis codes for two, three, and four transmit antennas" IEEE transactions on vehicular technology, vol. 53, no 2, March 2004
- [29] Khoirul Anwar and Tadashi Matsumoto, "MIMO spatial turbo coding with iterative equalization," IEEE Issue Date : 23-24 Feb. 2010 On page(s): 428 - 433 [Smart Antennas (WSA), 2010 International ITG Workshop on ]
- [30] Naveen Mysore and Jan Bajcsy, "BER bounding techniques for selected turbo coded mimo systems in rayleigh fading," IEEE Publication Year: 2010 , Page(s): 1 – 6 [Information Sciences and Systems(CISS), 2010 44th Annual Conference on]



**M. M. Kamruzzaman** was born in Bangladesh in 1978. He received B.E. degree in Computer Science and Engineering from Bangalore University, Bangalore, India in 2001, M.S. degree in Computer Science and Engineering from United International University, Dhaka, Bangladesh in 2009. At present he is studying PhD in the department of Information & Communication Engineering at Southwest Jiaotong University, Chengdu, Sichuan, China.

After completing B.E, he worked several universities as a faculty. He worked in Islamic Institute of Technology, Bangalore, India and Leading University, Dhaka, Bangladesh. And before studying PhD, he was working as a faculty of Presidency University, Dhaka, Bangladesh. He is a member of technical committee of ICCTD.

His areas of interest include wireless communications, modern coding theory, Turbo coding, Space Time Coding, Vblast, MIMO, OFDM, Relay and WCDMA system.