

# Personal Area Networks: Near-field intrabody communication

by T. G. Zimmerman

***As electronic devices become smaller, lower in power requirements, and less expensive, we have begun to adorn our bodies with personal information and communication appliances. Such devices include cellular phones, personal digital assistants (PDAs), pocket video games, and pagers. Currently there is no method for these devices to share data. Networking these devices can reduce functional I/O redundancies and allow new conveniences and services. The concept of Personal Area Networks (PANs) is presented to demonstrate how electronic devices on and near the human body can exchange digital information by capacitively coupling picoamp currents through the body. A low-frequency carrier (less than 1 megahertz) is used so no energy is propagated, minimizing remote eavesdropping and interference by neighboring PANs. A prototype PAN system allows users to exchange electronic business cards by shaking hands.***

**W**e are heading toward an electronic future where information will be accessible at our fingertips, whenever and wherever needed. Some of the computing and communication equipment required to provide this intimate and immediate access to information will be incorporated into our attire. Just as a glance at today's wristwatch saves a trip to the nearest clock, a glance at tomorrow's wristwatch will replace finding a terminal to check e-mail.

A person who carries a watch, pager, cellular phone, personal stereo, personal digital assistant (PDA), and notebook computer is carrying five displays, three keyboards, two speakers, two microphones, and three communication devices.<sup>1</sup> The duplication of I/O components is in part a result of the inability of the

devices to exchange data. With proper networking these devices can share I/O, storage, and computational resources.

The ability to share data increases the usefulness of personal information devices, providing features not possible with independent isolated devices. Imagine the following scenario: I am at home preparing for the day and want to find the time of my first meeting. I call out "When is my first meeting?" The microphone in my watch transmits my voice through a series of transponders distributed throughout my house to a voice recognition computer that searches my calendar and sends back a response to a speaker or visual display in my watch. When I leave my house the door senses my departure and sends a message to my colleagues. When I approach my office building, the door acknowledges me by opening, sends a message of my arrival to my colleagues, and uploads any new messages.

The scenario requires the user to wear a device that periodically transmits a unique user code to allow a nearby stationary transceiver to identify, locate, and exchange messages with the user's device. Clearly, privacy is a big issue in such scenarios. Privacy is both a right and a commodity. To maintain privacy control, a wearer must determine when the identification bea-

©Copyright 1996 by International Business Machines Corporation. Copying in printed form for private use is permitted without payment of royalty provided that (1) each reproduction is done without alteration and (2) the *Journal* reference and IBM copyright notice are included on the first page. The title and abstract, but no other portions, of this paper may be copied or distributed royalty free without further permission by computer-based and other information-service systems. Permission to *republish* any other portion of this paper must be obtained from the Editor.

con is activated and what type of information can be transmitted. Retail stores could encourage shoppers to transmit needed demographic information by providing perhaps a 5-percent discount to shoppers who leave their user profile beacons on.

The capabilities of autonomous yet interconnected devices may transform the notion of ubiquitous computing<sup>2</sup> to the concept of ubiquitous I/O. As wireless network ports become more common, there will be less need to carry around power-hungry processors and bulky mass storage. As the growth of wireless services (e.g., cellular phones, pagers, and radio frequency local area networks [RF LANs]) fills up the limited RF spectrum, near-field communication offers an alternative to congesting the airwaves with data.

### Previous work on electric field sensing

The development of the Personal Area Network (PAN) grew out of a meeting between Professor Mike Hawley's Personal Information Architecture Group and Professor Neil Gershenfeld's Physics and Media Group, both at the MIT Media Laboratory. Professor Hawley's group needed a means to interconnect body-borne information appliances,<sup>1</sup> and Professor Gershenfeld's group had been applying electric field sensing to position measurement.<sup>3</sup> Professor Gershenfeld and I realized that by modulating the electric field we were using for position measurement, we could send data through the body.

### Alternatives to near-field communication

Infrared (IR) communication is used in television remote control units and is becoming a popular means to network portable computers but is not practical for devices located inside wallets, purses, and pockets. Focused IR relies on line-of-sight transmission, which is difficult to maintain with body-based devices that are constantly in motion. Diffused IR relies on a wide-angle beam of high optical power requiring hundreds of milliwatts. Electrostatically coupled PAN devices use the body as a "wet wire" and can operate on several milliwatts of power.

Far-field (radio) communication is more susceptible to eavesdropping and interference than near-field communication due to the former's propagation properties: an isotropic radio transmitter propagates energy with a signal strength that decreases with distance squared, whereas near-field strength decreases with distance cubed. In addition, the earth shunts the

electric field, further attenuating the signal and making near-field communication more difficult to intercept. Some of the data communicated among PAN devices will be of a sensitive nature, for example, credit card and telephone numbers, client notes, diary entries, business communications, and computer passwords. Radio systems can be made secure with cryptographic strategies, requiring additional overhead, but the best security is a message that is never intercepted. Signal attenuation also reduces inter-PAN interference, an important consideration for meeting rooms and auditoriums filled with people wearing PANs. Frequency, time, and code division techniques may also be used to further prevent neighboring PAN systems from interfering with one another.

The fundamental difference between near-field and far-field communication is clearly demonstrated in antenna design. Near-field electrostatic coupling is proportional to electrode surface area. Far-field transmission efficiency is maximized by matching the impedance of the transmitter to free space, typically by using a half-wavelength antenna. PAN devices 25 to 80 millimeters long (e.g., a watch or credit card) would require a carrier of several gigahertz for efficient transmission. Since the energy consumed by electronic components increases with frequency, any increase in the frequency of the carrier beyond that required to contain the information increases energy consumption. Near-field communication can operate at very low frequencies (0.1 to 1 megahertz) that can be generated directly from inexpensive microcontrollers. For example, the prototype PAN transmitter operates at 330 kilohertz (KHz) at 30 volts with a 10-picofarad electrode capacitance, consuming 1.5 milliwatts discharging the electrode capacitance. A majority of this energy is conserved (recycled) by using a resonant inductance-capacitance (LC) tank circuit.

Far-field transmission is also subject to regulations and licensing that vary from country to country. Near-field communication avoids these complications; for example, the PAN prototype (about the size of a thick credit card) has a field strength of 350 picovolts per meter at 300 meters, 86 decibels (dB) below the field strength allowed by the Federal Communications Commission.

The PAN is based on the seven-layer ISO 7498 network standard<sup>4</sup> of the International Organization for Standardization. The work presented here concerns the physical layer, examining the electrical properties of the communication channel, and the second layer,

Figure 1 Block diagram of a PAN system

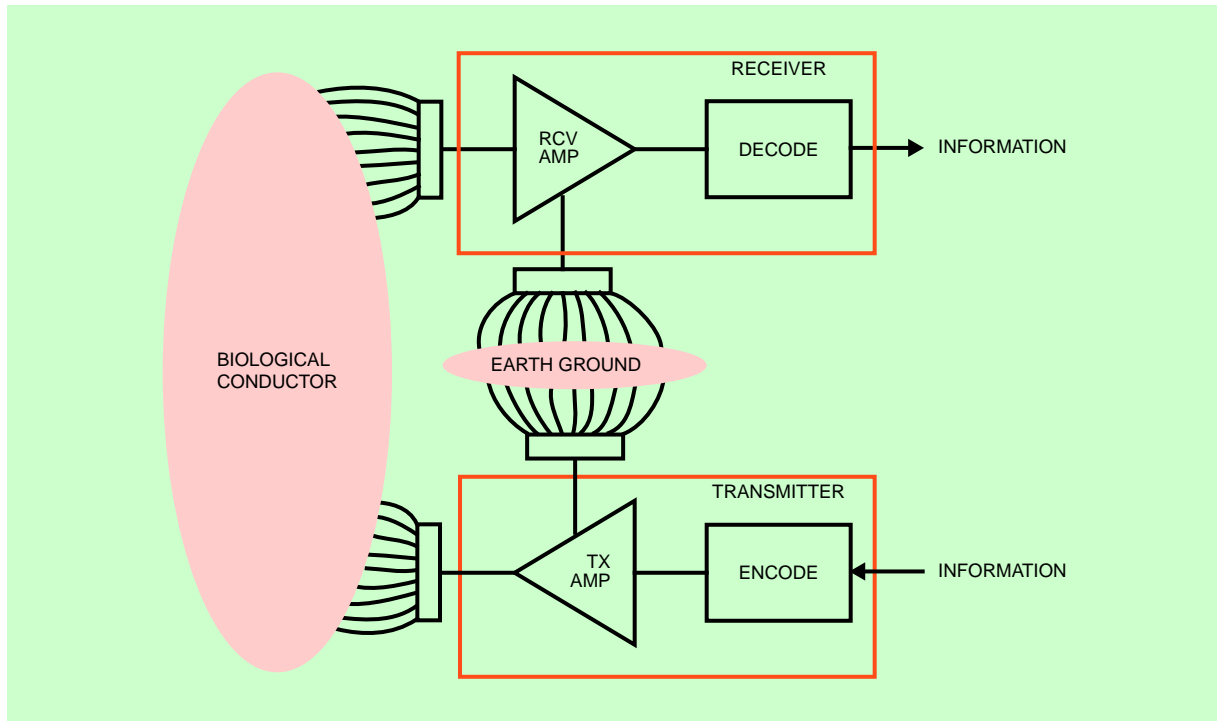

establishing a reliable information link. The third layer would connect PAN devices to specific applications.

### Basic concept of a PAN communication channel

Figure 1 shows a PAN transmitter communicating with a PAN receiver. Both devices are battery powered, electrically isolated, and have a pair of electrodes. The PAN transmitter capacitively couples a modulating picoamp displacement current through the human body to the receiver. The return path is provided by the “earth ground,” which includes all conductors and dielectrics in the environment that are in close proximity to the PAN devices. The earth ground needs to be electrically isolated from the body to prevent shorting of the communication circuit.

### Lumped model of communication channel: Symmetry breaking

In Figure 2 the PAN transmitter is modeled as an oscillator, and the receiver is modeled as a differential

amplifier. The basic principle of a PAN communication channel is to break the impedance symmetry between the transmitter electrodes and receiver electrodes. The transmitter’s and receiver’s inraelectrode impedances are ignored since the former is a load on an ideal voltage source and the latter is modeled as an open circuit. The four remaining impedances are labeled A, B, C, and D.

The circuit is rearranged to show how PAN device communication works by breaking the symmetry between the four electrodes. The circuit is a Wheatstone bridge where any imbalance of the relationship  $A/B = C/D$  will cause a potential across the receiver. Since the ratios must be exactly equal in order to null the circuit, and body-based PAN devices are constantly in motion, there will nearly always be an electrical communication path, as long as the receiver is sensitive enough to detect the imbalance.

### PAN device electric field model

A more detailed electrical model is derived by identifying all the electric field paths in the system. Electric

Figure 2 Electrical lumped model of PAN transmitter (oscillator) and receiver (differential amp)

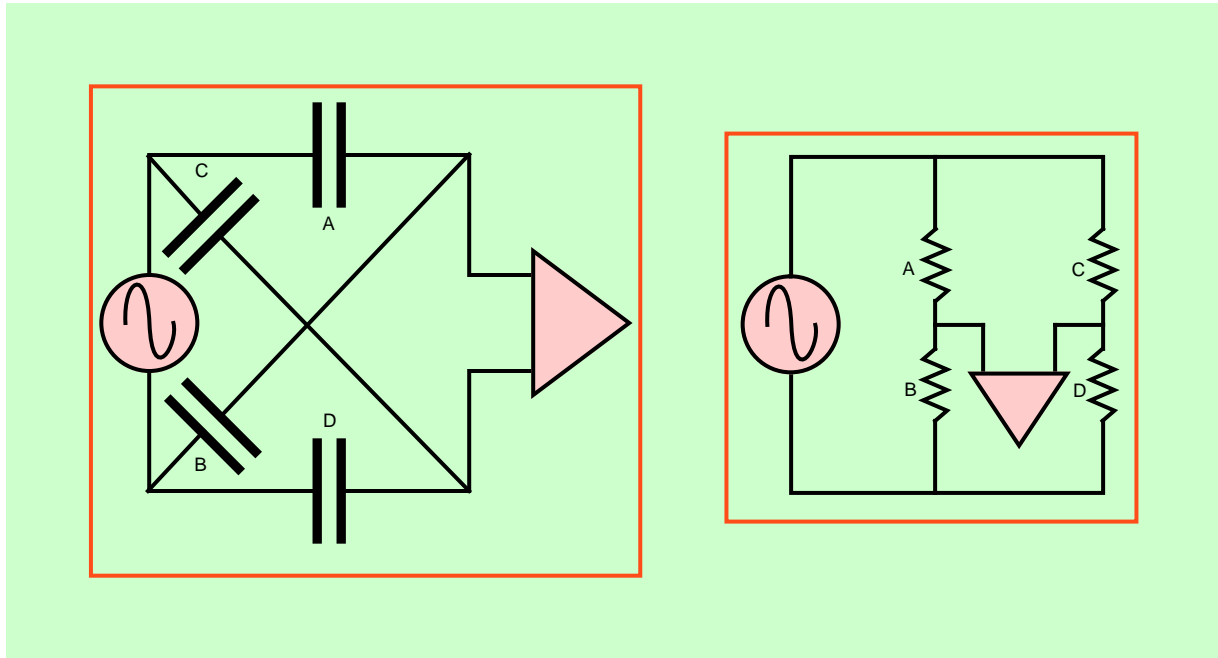

Figure 3 Electric fields produced by PAN transmitter T

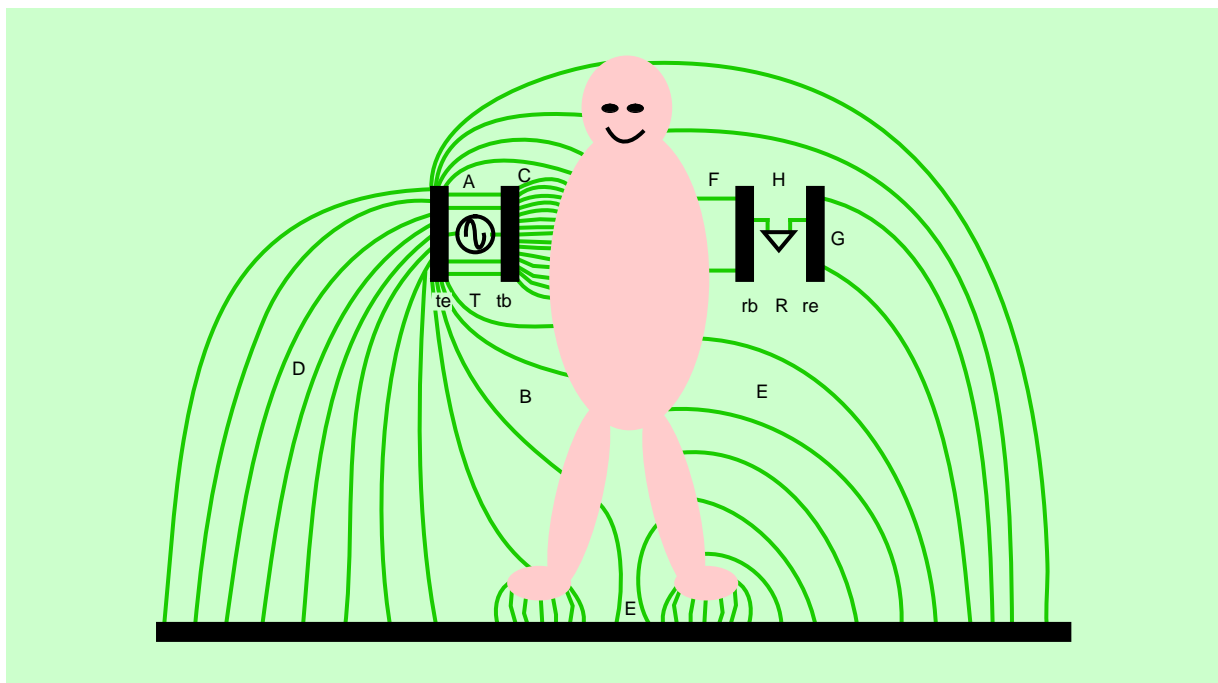
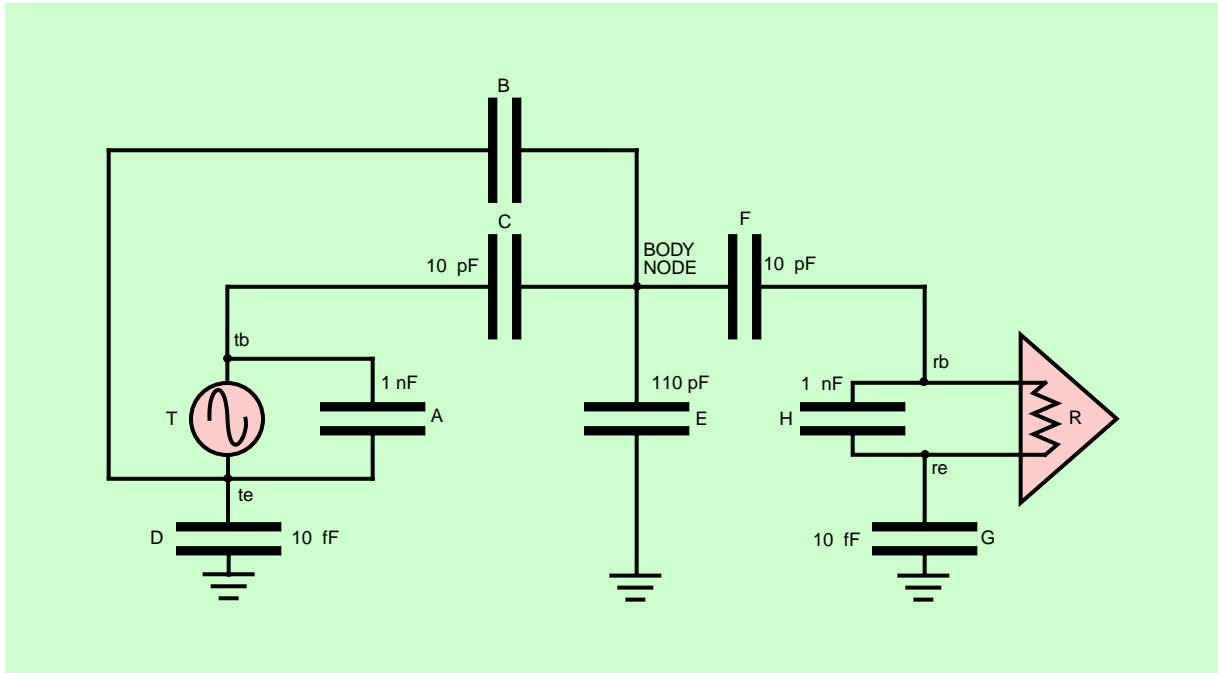

Figure 4 Electrical model of PAN system



fields exist between bodies at different potentials. Figure 3 illustrates an electric field model of a PAN transmitter T communicating with a PAN receiver R. A small portion of the electric field G reaches the receiver R.

The transmitter T electrode closest to the body  $tb$  has a lower impedance to the body than the electrode facing toward the environment  $te$ . This enables the transmitter T to impose an oscillating potential on the body, relative to the earth ground, causing electric fields A, B, C, D, and E.

Similarly the impedance asymmetry of the receiver electrodes ( $rb$  and  $re$ ) to the body and environment allow the displacement current from electric fields F and G to be detected. Since the impedance between the receiver electrodes is nonzero, a small electric field H exists between them.

The electric fields model is used to produce the electric circuit shown in Figure 4. Some typical component values are shown for watch-based PAN devices. The transmitter T capacitively couples to receiver R through the body (modeled as a perfect conductor).

The earth ground provides the return signal. The circuit reveals that body capacitance to the environment E degrades PAN communication by grounding the potential that the transmitter T is trying to impose on the body. For example, in one experiment, standing barefoot reduced communication between wrist-mounted devices by 12 dB.

The circuit model also suggests that feet are the best location for PAN devices, providing large electrodes in close proximity to the body and environment, respectively. This is particularly true for the environment electrode ( $te$  or  $re$ ), which is the weakest link (largest impedance) in the circuit. The location also suggests a novel power source: PAN devices embedded in shoe inserts that extract power from walking. An adult dissipates several hundred milliwatts while walking. A piezoceramic pile charging a capacitor at an efficiency as low as 10 percent can provide enough power for a PAN device.

### PAN locations and applications

PAN devices can take the shape of commonly worn objects: watches, credit cards, eyeglasses, identifica-

**Figure 5** Locations and applications for PAN devices include head-mounted display, headphones, identification badge, cellular phone (in waist pack), credit and phone cards (in wallet), watch with display, microphone and speaker, and “power sneakers” (self-powering computer shoe inserts).

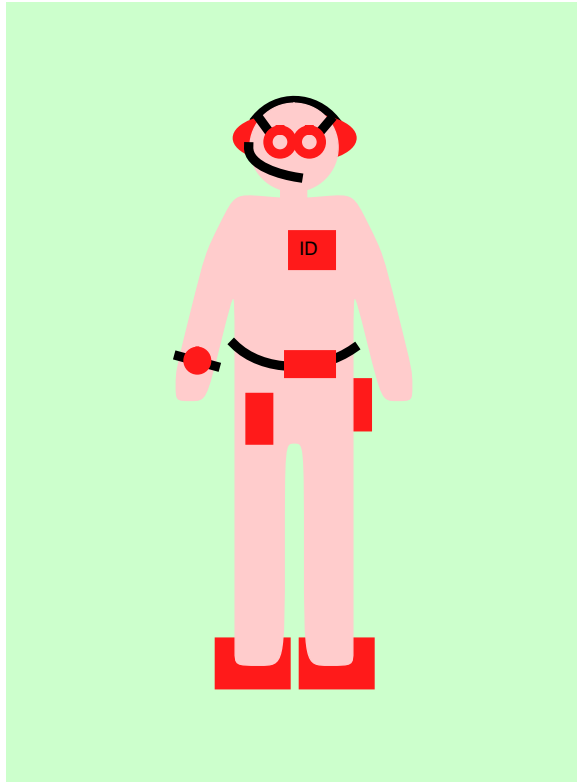

tion badges, belts, waist packs, and shoe inserts, as shown in Figure 5. Head-mounted PAN devices can include headphones, hearing aids, microphones, and head-mounted displays. Shirt pocket PAN devices may serve as identification badges. The wristwatch is a natural location for a display, microphone, camera, and speaker. A waist pouch can carry a PDA, cellular phone, keypad, or other devices that are large and heavy. PAN devices incorporating sensors can provide medical monitoring for such bodily functions as heartbeat, blood pressure, and respiratory rate. Pants pockets are a natural location for wallet-based PAN devices to store information and identify the possessor. Shoe inserts can be self-powered and provide a data link to remote PAN devices located in the environment, such as workstations and floor transponders that detect the location and identity of people.

## Channel capacity

A communication network is judged primarily by channel capacity, with a theoretical limit defined by the Hartley-Shannon law<sup>5</sup>  $C = B \log(1 + S/N)$ , where  $C$  is channel capacity in bits/second,  $B$  is bandwidth,  $S$  is signal, and  $N$  is noise. The  $-3$  dB bandwidth of the prototype PAN receiver is 400 KHz (100 KHz to 500 KHz), resulting in a maximum channel capacity of 417 kilobits (Kbits) per second, assuming a robust signal-to-noise ratio of 10. The PAN transceiver prototype implements a modest 2400 bits-per-second modem.

## Development of a PAN prototype

A PAN prototype has been developed to demonstrate the digital exchange of data through a human body using battery-powered low-cost electronic circuitry. The detector is a current amp (gain = 106) followed by an analog bipolar chopper controlled by a digital microcontroller, as shown in Figure 6. The detector synchronously integrates the tiny received displacement current (e.g., 50 picoamperes, 330 KHz) into a voltage that can be measured by a slow, low-resolution analog-to-digital converter (50 KHz, 8 bits) provided by the microcontroller. The PAN transceiver uses five “off-the-shelf” components costing less than \$10 in large volumes. Ultimately the analog components and microcontroller can be combined into a single CMOS (complementary metal-oxide semiconductor) integrated circuit to produce a low-cost integrated PAN transceiver.

The transmitter is an LC tank ( $Q = 6$ ) made from a surface-mount inductor and the inherent electrode capacitance. The resonant tank circuit produces a clean sine wave output from a square wave input, minimizing RF harmonics, and boosts the output voltage in proportion to the  $Q$  of the tank. The transmit voltage can also be digitally programmed by varying the pulse width of the driving square wave. The integrator is discharged after every message bit (integrate-and-dump filtering) to minimize intersymbol interference.<sup>5</sup>

## Modulation strategies

Two modulation strategies were examined for PAN communication: on-off keying and direct sequence spread spectrum. On-off keying turns the carrier on to represent a message bit one and turns the carrier off for a message bit zero. The signal-to-noise performance is improved by increasing the transmit voltage.

Figure 6 Block diagram of half-duplex PAN transceiver

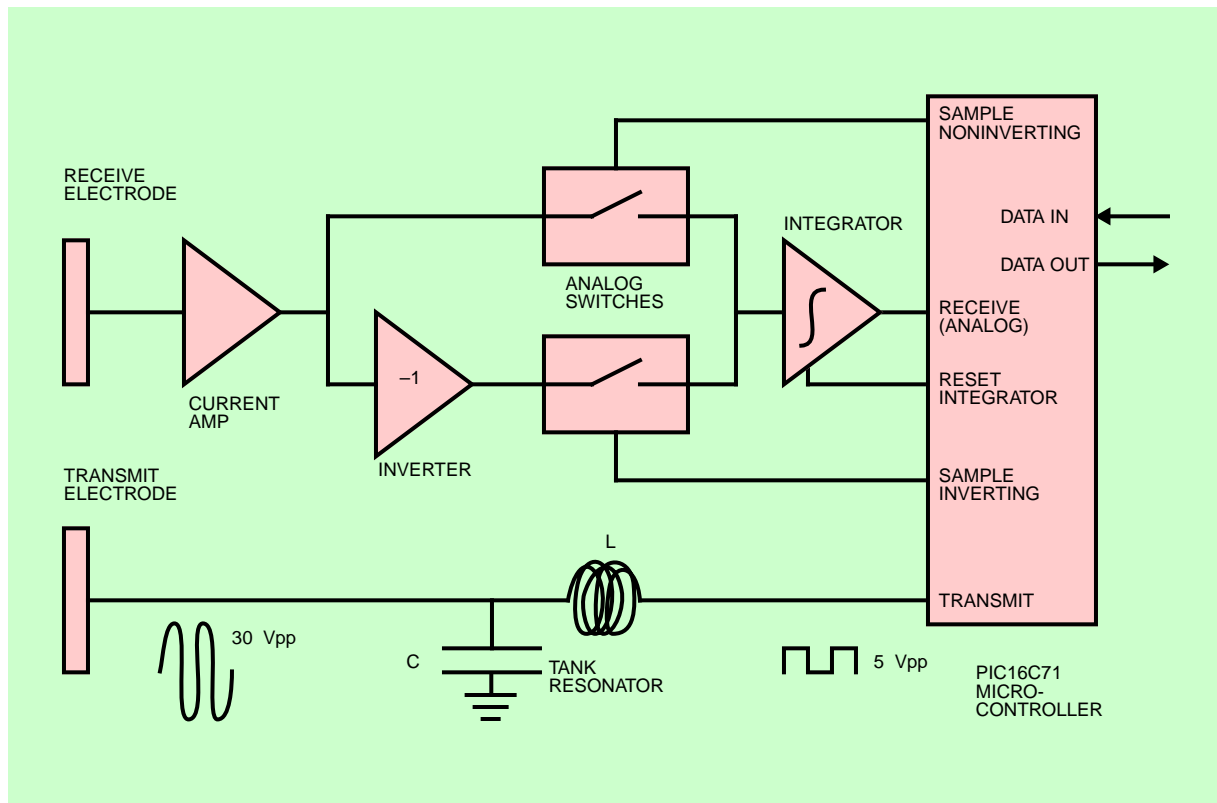

Direct sequence spread spectrum modulates the carrier with a pseudonoise (PN) sequence, producing a broadband transmission much greater than the message bandwidth. Symbol-synchronous PN modulation is used where a message bit one is represented by transmitting the entire PN sequence, and a message bit zero is represented by transmitting the inverted PN sequence. The signal-to-noise performance increases with the length of the PN sequence.

The prototype hardware is capable of detecting either on-off keying or direct sequence spread spectrum, determined by microcontroller coding. For on-off keying the bipolar chopper switches are driven at the carrier frequency, and the integrated result is compared to a fixed threshold to determine the value of the message bit. Quadrature detection is implemented by performing two sequential integrations, at 0 and 90 degrees phase, for each message bit. For spread spectrum the switches are driven by the PN sequence, and the integrated result, which is the correlation, is com-

pared to two thresholds. If the correlation is greater than a positive threshold, the message bit is one. If the correlation is less than a negative threshold, the message bit is zero. If the correlation is between these thresholds (the dead zone), no message bit is received.

Once the message has been successfully received and demodulated, the microcontroller transmits the message to a host computer over an optical link (not shown), which electrically isolates the transceiver allowing evaluation and debugging independent of an electrical ground reference.

### The business card handshake

The demonstration prototype of the PAN system, shown in Figure 7, consists of a battery-powered transmitter and receiver, and a host computer running a terminal program. The PAN prototypes measure  $8 \times 5 \times 1$  centimeters, about the size of a thick credit card. The transmitter contains a microcontroller that contin-

Figure 7 PAN demonstration system



ously transmits stored ASCII characters representing an electronic business card. The devices are located near the feet, simulating PAN shoe inserts.

When the woman and man depicted in the figure are in close proximity, particularly when they shake hands, an electric circuit is completed, allowing pico-amp signals to pass from the transmitter through her body, to his body, to the receiver by his foot, and back through the earth ground. ASCII characters are sent to the receiver, demodulated, and sent via serial link to the host computer where they are displayed. Thus, when they shake hands, the woman downloads her electronic business card to the man.

## Conclusion

This research has uncovered a novel means to perform local communication using electric fields. The trade-offs among cost, speed, size, power, and operating range must be further studied and quantified in order

to engineer practical PAN devices. Many of the design and engineering techniques of radio and digital communication can be applied to PAN devices.

Telephone modems have pushed modulation and digital signal processing techniques to their practical limits. The application of modem telephony techniques to PAN devices may deliver channel capacities of 100 Kbits per second. Data compression will also increase the effective capacity of a PAN communication channel.

The concept of power sneakers is intriguing. Shoes are something that we almost always have with us, are unlikely to lose, and are difficult to steal. Networked shoes could keep track of whom we meet, where we have been, and what we have done. When we walk by a store, advertisements could upload to our shoes, sticking like digital chewing gum. Homework assignments, grades, shopping lists, errands, and reminders could be automatically exchanged among family members at the dinner table.



The research has explored the first two layers of a network. The upper layers must be designed to make a practical PAN. Applications need to be deeply considered. Privacy issues are raised when personal data can effortlessly be exchanged. As with other communication and data systems, there is a trade-off among access, convenience, and security.

The sensitivity and bit rate must be increased in order to realize a watch-sized PAN transceiver. The low-frequency carrier of near-field communication makes direct sequence spread spectrum both practical and desirable. Ultimately PAN devices will be judged a success when they appear as common useful objects that perform magic—from picture telephone “Dick Tracy” watches to self-powered smart sneakers that seamlessly interconnect us to a worldwide information and communication network.

## Acknowledgments

This research was sponsored in part by Hewlett-Packard Corporation and the Festo Didactic Corporation and was conducted at the Physics and Media Group of the MIT Media Laboratory.

## Cited references

1. O. Shivers, *BodyTalk and the BodyNet: A Personal Information Infrastructure*, *Personal Information Architecture Note 1*, MIT Laboratory for Computer Science, Cambridge, MA (December 1, 1993).
2. M. Weiser, “The Computer for the 21st Century,” *Scientific American* **265**, No. 3, 94–104 (September 1991).
3. T. G. Zimmerman, J. R. Smith, J. A. Paradiso, D. Allport, and N. Gershenfeld, “Applying Electric Field Sensing to Human-Computer Interfaces,” *CHI’95 Human Factors in Computing Systems*, Denver, May 9–11, 1995, ACM Press, New York.
4. W. Stalling, *Networking Standards*, Addison-Wesley Publishing Co., Reading, MA (1993), pp. 23–26.
5. A. B. Carlson, *Communication Systems*, Third Edition, McGraw-Hill Book Company, New York (1986), pp. 230, 401, 514–536, 554.

## General references

- B. H. Brown, D. C. Barber, and A. D. Seager, “Applied Potential Tomography, Possible Clinical Applications,” *Clinical Physics and Physiological Measurement* **6**, No. 2, 109–122 (1985).
- T. H. Bullock, “Electroreception,” *Annual Review of Neuroscience* **5**, 121–170 (1982).
- Electrical Impedance Tomography*, J. G. Webster, Editor, Adam Hilger (publisher), New York (1989).
- J. Fraden, *AIP Handbook of Modern Sensors*, American Institute of Physics, New York (1993), p. 421.

N. Gershenfeld, *Method and Apparatus for Electromagnetic Non-Contact Position Measurement with Respect to One or More Axes*, U.S. Patent No. 5,247,261 (September 21, 1993).

N. Gershenfeld, T. G. Zimmerman, and D. Allport, *Non-Contact System for Sensing and Signaling by Externally Induced Intra-Body Currents*, U.S. Patent Application (May 8, 1995).

P. Kealey and M. Brooks, *An Introduction to Geophysical Exploration*, Second Edition, Blackwell Scientific Publications, Oxford, UK (1991), p. 216.

J. P. Mills, *Electromagnetic Interference*, Prentice-Hall, Inc., Englewood Cliffs, NJ (1993), p. 143.

W. I. Orr, *Radio Handbook*, Twenty-Third Edition, Howard W. Sams & Company, Indianapolis, IN (1987), ch. 22, p. 6.

K. Pahlavan, T. H. Probert, and M. E. Chase, “Trends in Local Wireless Networks,” *IEEE Communications Magazine* **33**, No. 3, 88–95 (March 1995).

*Part 15 Radio Frequency Devices*, Federal Communications Commission, Washington, DC (1993).

S. Ramo, J. R. Whinnery, and T. Van Duzer, *Fields and Waves in Communication Electronics*, Third Edition, John Wiley & Sons, Inc., New York (1994), pp. 254–256.

J. R. Smith, *Towards Electric Field Imaging*, M.S. thesis, MIT Media Laboratory, Cambridge, MA (September 1995).

D. A. Weston, *Electromagnetic Compatibility*, Marcel Dekker Publishers, New York (1991), p. 36.

T. G. Zimmerman, *Personal Area Networks (PAN): Near-Field Intra-Body Communication*, M.S. thesis, MIT Media Laboratory, Cambridge, MA (September 1995).

*Accepted for publication April 8, 1996.*

**Thomas G. Zimmerman** *IBM Research Division, Almaden Research Center, 650 Harry Road, San Jose, California 95120-6099 (electronic mail: TZIM@almaden.ibm.com)*. Mr. Zimmerman is a research staff member in the Computer Science Department of the IBM Almaden Research Center, working on new human/machine interface devices and paradigms. He received his B.S. in humanities and engineering and an M.S. in media science from MIT. In collaboration with Neil Gershenfeld, he developed the Personal Area Network at the MIT Media Lab. In the early 1980s he invented the DataGlove and cofounded VPL Research. His interest in music led him to cofound Breakaway Technologies, where he designed a voice-controlled synthesizer, and later he patented several musical devices to help people sing and play music. His interactive exhibits can be seen at the Exploratorium in San Francisco and the National Geographic Society in Washington, DC.

Reprint Order No. G321-5627.