

# PHARMACOLOGICAL STUDIES ON THE HEART OF *TAPES WATLINGI*: A MOLLUSC OF THE FAMILY VENERIDAE

BY

G. C. CHONG AND J. W. PHILLIS

*From the Department of Physiology, Monash University, Clayton, Victoria, Australia*

(Received February 10, 1965)

The extreme sensitivity to acetylcholine of the heart of *Venus mercenaria*, a lamellibranch mollusc, was first reported by Prosser & Prosser (1937). Acetylcholine has since been shown to duplicate the actions of the endogenously released cardioinhibitory transmitter, with which it is considered identical (Prosser, 1940; Welsh & Slocombe, 1952). Since both the sensitivity and specificity of the heart of *Venus mercenaria* towards acetylcholine are of a high order, the preparation has been extensively used as a test object for the bioassay of this substance (Smith & Levin, 1938; Wait, 1943; Tower and McEachern, 1948).

5-Hydroxytryptamine has a powerful excitatory action on the *Venus* heart (Welsh, 1953) and the effects of a range of indole and catechol amines and related compounds on this preparation have been determined (Greenberg, 1960a, b; Wright, Moorhead & Welsh, 1962). 5-Hydroxytryptamine has a similar action to the substance released by stimulation of the cardioacceleratory nerves to the heart and, as it occurs in molluscan nerve tissue and heart in relatively high concentrations (Welsh & Moorhead, 1959), it has been suggested that 5-hydroxytryptamine is the cardioexcitatory transmitter (Welsh, 1953; Loveland, 1963). Concentrations of 5-hydroxytryptamine as low as  $10^{-10}$  M will excite the *Venus* heart, which is therefore suitable for the bioassay of this substance as well as of acetylcholine.

*Venus mercenaria* is not obtainable in Australia and it has therefore been necessary to investigate the suitability of local members of the family Veneridae for the bioassay of acetylcholine and 5-hydroxytryptamine. In an early survey, Ladd & Thorburn (1955) selected the Tapestry cockle, *Tapes watlingi* (previously called *Tapes turgida*, see Iredale, 1958), as a suitable replacement for *Venus mercenaria*, and this species has been investigated in the present survey. The results described below indicate that the *Tapes* heart, which is very similar in its pharmacological responses to the *Venus* preparation, can be satisfactorily used for the bioassay of acetylcholine. It is less adequate as a test object for 5-hydroxytryptamine, being apparently only one-tenth to one-hundredth as sensitive to this compound as the *Venus* heart. Some preliminary observations on the pharmacology of the rectum of *Tapes watlingi* are included in the paper.

## METHODS

The method of preparation of the *Tapes* heart was essentially the same as that described by Ladd & Thorburn (1955). Supplies of the mollusc were obtained in Sydney and air-freighted to Melbourne. Upon arrival they were transferred to a salt-water aquarium in the laboratory. Fresh sea water was obtained at frequent intervals and the water in the aquarium was renewed at least twice weekly. The aquarium was maintained at room temperature and compressed air was bubbled through continuously. Under these conditions the molluscs could be kept for several weeks, and some survived for periods greater than 4 months. It was soon discovered, however, that the death of one specimen usually led to the rapid deterioration of the others in its tank, and for this reason several aquaria, containing a few specimens each, were found to be the most satisfactory method of storing the molluscs.

To expose the heart, the valves of the shell were separated by inserting a scalpel blade between them and cutting the anterior and posterior adductor muscles. After the muscle had been scraped from the uppermost valve, the shell was opened, revealing the heart beating slowly within its pericardial sac. (The position of the heart within the shell and its appearance are clearly demonstrated in Fig. 1 of Ladd & Thorburn's paper.) After the mantle and pericardium overlying the heart had been reflected, threads were attached at each end of the ventricle and the atrioventricular-rectal complex was isolated by cutting the anterior and posterior blood vessels together with the rectum. Atrioventricular ligatures, which are used to suspend the ventricular preparation of the *Venus* heart, were not used in the present investigation as the two fragile atria are located on the lower surface of the ventricle in close apposition. Aortic ties were also used by Ladd & Thorburn (1955).

The responses of preparations which included the rectum were compared with those of the heart alone from which the rectum had been removed before attaching ligatures to the ventricle. Preparations with the rectum still present occasionally exhibited tonic periodic changes in baseline tone (Fig. 1*a,b*). These could be abolished by making a small incision in the ventricular wall and sectioning the rectum. The cardio-rectal complex has been used as the standard preparation for bioassay of acetylcholine, as the less traumatic method yielded a higher proportion of satisfactory preparations.

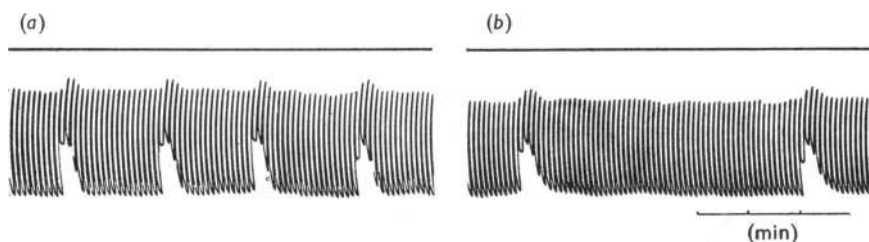

Fig. 1. (*a*) and (*b*): records from two preparations in which the rectum was still present, demonstrating the tonic periodic changes in baseline caused by contraction of the rectum.

The isolated heart was placed in a small (1 ml.) Perspex organ-bath (Fig. 2) supplied with an outlet tube for emptying. This type of bath represents a departure from the conventional 10 ml. temperature-regulated chamber which has hitherto been used for studies on *Venus* and *Tapes* hearts and its limited volume makes it particularly suitable for assaying small samples, such as effluents from the central nervous system. The bath was drained, and the solutions to be assayed were poured into it, allowed to act for the appropriate time and then replaced by the perfusion fluid. This procedure does not appear to be deleterious to the preparation, and the brief periods of distortion of the recording of cardiac contractions does not interfere with estimations of the effects of solutions.

The sensitivity of the *Tapes* heart to acetylcholine is not as dependent on the ambient temperature as is that of the *Venus* heart (Ladd & Thorburn, 1955) and all the experiments in this series were carried out at room temperature (20 to 22° C). Sea water has proved to be a satisfactory perfusion medium for the *Tapes* heart and aeration of the perfusion fluid was found to be unnecessary. Drugs were routinely applied for 1 min periods (apart from the anticholinergic compounds and methysergide).

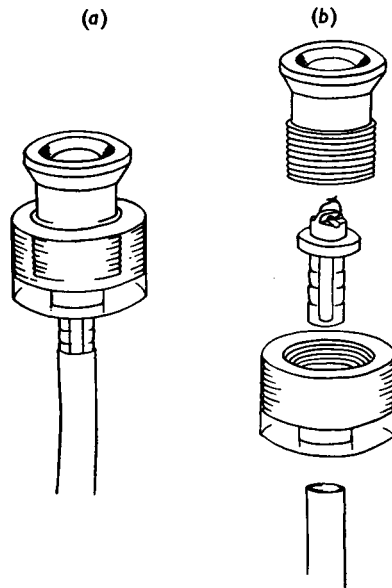

Fig. 2. Views of the assembled (a) and dismantled (b) organ-bath used in these experiments.

Contractions of the heart were measured using a flexible straw lever system coupled to a Grass Model FT. 03 strain gauge. This arrangement permitted the ventricle to contract isotonically and was considerably more successful than an earlier method in which the ventricle was coupled directly to the strain gauge.

An isolated preparation of the rectum of *Tapes watlingi* has been tested in some of the experiments. The rectum was attached to the ventricle only at the points where it enters and leaves the latter. Removal of the myocardium of the ventricle from the intestine was readily achieved by incising the ventricular wall and gently freeing the intestine at its points of attachment. Ligatures were then placed at either end of the rectum and it was suspended in the same bath as the hearts.

## RESULTS

### *Acetylcholine and related compounds*

The inhibitory effects of acetylcholine on the *Tapes* heart have been described by Ladd & Thorburn (1955) and are similar to its effects on the *Venus* heart (Prosser, 1940; Wait, 1943; Tower & McEachern, 1948). The most conspicuous effect of small doses of acetylcholine was a reduction in the amplitude of systolic contractions. The extent of the inhibition depended on the concentration of acetylcholine. Typical responses are illustrated in Fig. 3,*a*. With some preparations a different type of response was evident, namely a reduction in the frequency of contraction, which was not necessarily accompanied by a reduction in the amplitude of the beat (Fig. 3,*b*). Acetylcholine was routinely applied for periods of 1 min at 5 min intervals and the amount of inhibition was estimated by comparing the average height of all the contractions during the period of application with the height of the control responses before and after the period of application. A comparison of the average height of the responses was necessitated by the partial recovery from inhibition which occurs during the period of application of acetylcholine.

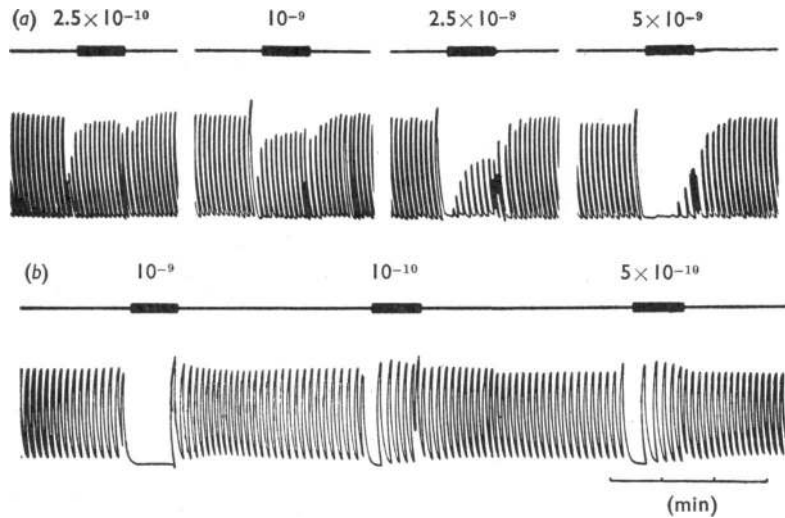

Fig. 3. Typical responses of the heart of *Tapes watlingi* to acetylcholine. (a): the threshold concentration of acetylcholine for this heart was  $2.5 \times 10^{-10}$  M; higher concentrations caused a reduction in the amplitude and frequency of the beat. (b): another form of response to acetylcholine, which caused a reduction in the frequency but not the amplitude of the beat. Concentrations in M above signal marks.

The dose/response curve of a typical preparation is illustrated in Fig. 4. The threshold dose of acetylcholine was usually of the order of  $5 \times 10^{-10}$  M and sensitivity tended to increase slightly during the course of the experiment. Physostigmine and neostigmine ( $10^{-5}$  M) had very little effect on the sensitivity of the ventricles to acetylcholine and, as recovery after an application was prolonged by anticholinesterases, these were not used.

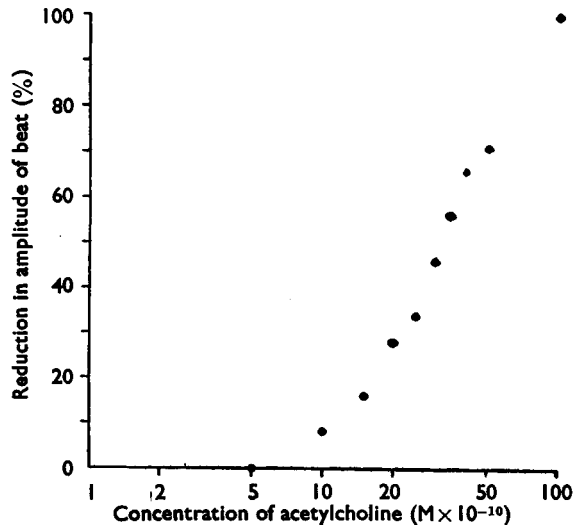

Fig. 4. Concentration/response curve for acetylcholine. Each point is the mean of two determinations.

Concentrations of acetylcholine which were just subthreshold for an inhibitory action frequently slightly augmented the amplitude of contractions, and after benzoquinonium (Mytolon; WIN 2747) higher concentrations of acetylcholine had a strong excitatory action on the heart (Fig. 5).

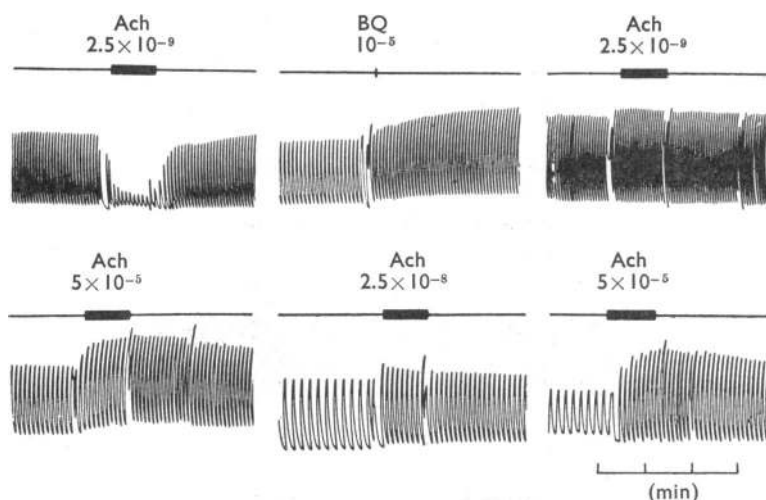

Fig. 5. Excitant action of acetylcholine (Ach) on the *Tapes* heart after treatment with benzoquinonium (BQ). Acetylcholine ( $2.5 \times 10^{-9}$  M) initially inhibited the heart. Benzoquinonium solution ( $10^{-5}$  M) was then perfused through the bath for 25 min revealing an excitant action of subsequent applications of acetylcholine. All concentrations in M.

A summary of the inhibitory potencies of a number of cholinergic compounds is presented in Table 1. The relative potencies were determined by finding the molar concentrations of each compound which produced a similar degree of inhibition to a given molar concentration of acetylcholine. The figures in Table 1 represent the averages of several such determinations and are roughly comparable with those obtained on the *Venus* heart by Welsh & Taub (1948). Arecoline, propionylcholine and butyrylcholine all excited the

TABLE 1

A COMPARISON OF THE RELATIVE INHIBITORY POTENCIES OF A SERIES OF CHOLINERGIC COMPOUNDS ON THE HEARTS OF *TAPES WATLINGI* AND *VENUS MERCENARIA*

Values for *Venus* are from Welsh & Taub (1948). Drugs were used as chloride, except for arecoline (hydrobromide)

Relative concentrations (M) which caused a similar decrease in beat amplitude

Compound	<i>Tapes</i> heart		<i>Venus</i> heart Average
	Individual estimates	Average	
Acetylcholine		1	1
Carbamylcholine	2.5, 10, 20, 30, 50	22.5	80
Arecoline	20, 50, 50, 100	55	
Propionylcholine	30, 100, 100, 100	82.5	105
Butyrylcholine	100, 200, 600, 1,000	475	625
Acetyl- $\beta$ -methylcholine	500, 500, 1,000, 1,000, 1,200	1,050	1,100
Choline	Weak inhibition at $10^{-4}$ M		14,000

heart when applied after benzoquinonium, their potencies for this excitant action being about one-tenth of that of acetylcholine.

Nicotine ( $10^{-7}$  to  $10^{-5}$  M) had an excitant action on the *Tapes* heart, although it causes inhibition at similar concentrations on the *Venus* heart (Welsh & Taub, 1950). The excitant action of nicotine (Fig. 6,*a*) was manifested in an increase in the amplitude of contractions, although this frequently appeared to be both preceded and followed by an inhibitory effect. Tetramethylammonium and tetraethylammonium ions ( $10^{-7}$  to  $10^{-5}$  M) had weakly excitant actions on the *Tapes* heart.

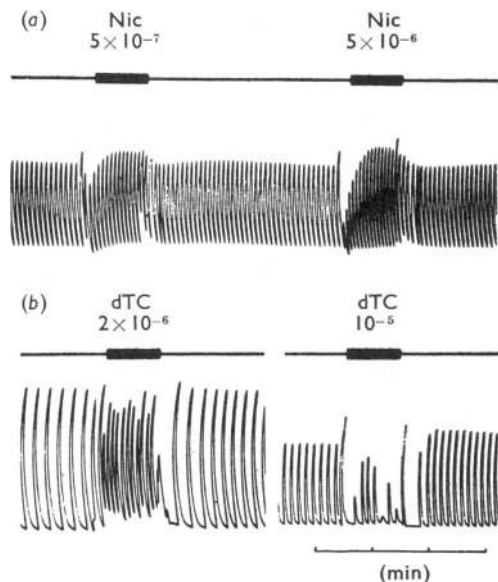

Fig. 6. The effects of nicotine (Nic) and tubocurarine (dTC). (*a*): nicotine ( $10^{-7}$  M) had an excitant action on this heart which was not greatly enhanced by a tenfold increase in concentration. (*b*): responses from two hearts showing variable effects of tubocurarine. All concentrations in M.

#### *The action of acetylcholine antagonists*

In their preliminary report on the pharmacology of the *Tapes* heart, Ladd & Thorburn (1955) discussed the failure of atropine to modify the inhibitory action of acetylcholine, but did not mention further studies with antagonists of acetylcholine. Extensive investigations into the action of acetylcholine antagonists on the *Venus* heart (Ludueña & Brown, 1952; Welsh & Taub, 1953) have revealed that benzoquinonium is the most powerful of those tested. A series of acetylcholine antagonists has been tested in the course of the present investigations in order to ascertain further the degree of similarity between the receptors on *Tapes* and *Venus* hearts (Table 2). Each drug was applied for 15 min before testing with acetylcholine.

In agreement with the findings reported for *Venus* hearts (Ludueña & Brown, 1952; Welsh & Taub, 1953) benzoquinonium proved to be an extremely effective antagonist of acetylcholine on the *Tapes* heart. At concentrations of  $10^{-6}$  to  $10^{-5}$  M benzoquinonium

TABLE 2  
ACETYLCHOLINE ANTAGONISTS TESTED ON THE TAPES HEART

Drugs forming salts were used as chloride or hydrochloride, except for atropine (sulphate) and gallamine (triethiodide)

Compound	Concentration (M)	Antagonism of acetylcholine
Benzoquinonium	$10^{-6}$ – $10^{-5}$	Complete inhibition
Atropine	$10^{-5}$	Usually inactive
Hyoscine	$10^{-5}$	Inactive
Tubocurarine	$10^{-6}$	Inactive
Dihydro- $\beta$ -erythroidine	$10^{-5}$	Inactive
Hexamethonium	$10^{-5}$	Inactive
Decamethonium	$10^{-5}$	Inactive
Gallamine	$10^{-5}$	Inactive
Mecamylamine	$10^{-5}$	Inactive
Benactyzine	$10^{-5}$	Inactive
Procyclidine	$10^{-5}$	Inactive
Trasentin	$10^{-5}$	Inactive
Caramiphen	$10^{-5}$	Inactive

blocked the effects of doses of acetylcholine which were sufficient to inhibit completely cardiac contractions (Fig. 5 and 7). Benzoquinonium frequently had an excitant action on the *Tapes* heart and its ability to reveal an underlying excitatory action of acetylcholine, propionylcholine, butyrylcholine and arecoline has already been mentioned. For routine assaying, benzoquinonium has been used at a concentration of  $10^{-5}$  M to inhibit the action of acetylcholine and related substances.

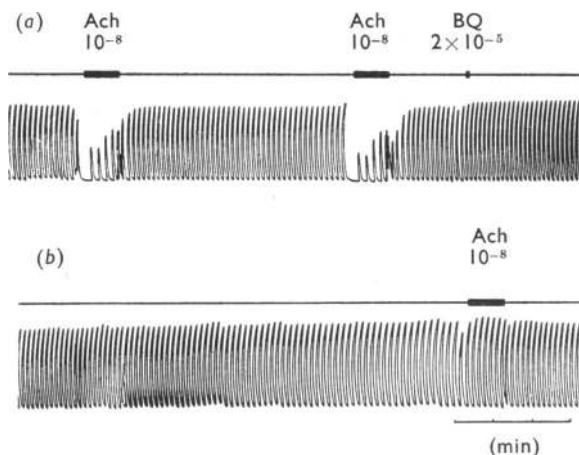

Fig. 7. The effect of benzoquinonium (BQ) on responses to acetylcholine (Ach). The tracings are continuous. Acetylcholine ( $10^{-8}$  M), which consistently inhibited the heart before the application of benzoquinonium, had only a slightly excitant action when applied 15 min after the commencement of perfusion with benzoquinonium ( $2 \times 10^{-5}$  M). All concentrations in M.

Variable results were obtained when atropine was used as an acetylcholine antagonist: on two preparations at a concentration of  $10^{-7}$  M it caused quite a large reduction in the inhibitory action of acetylcholine but on other preparations atropine failed to alter the action of acetylcholine. This result was consistent with those reported for *Venus* heart,

on which atropine lacks an acetylcholine blocking action at all but very high concentrations (Welsh & Taub, 1953).

(+)-Tubocurarine had an interesting effect on the heart when applied at concentrations of  $10^{-6}$  to  $10^{-4}$  M, causing an increased frequency of beat of some preparations and a decreased frequency of others, associated with a decreased amplitude of contraction and frequently a rise in the baseline (Figs. 6, *b* and 8). The beats were often irregular and the effects of consecutive applications of the same dose of tubocurarine frequently differed

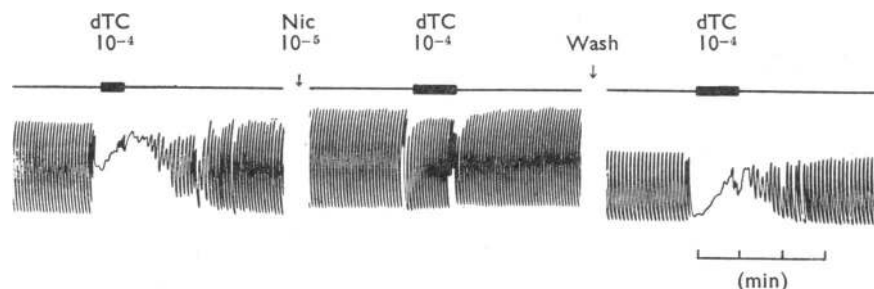

Fig. 8. The effect of tubocurarine (dTC,  $10^{-4}$  M) was greatly reduced after the heart had been perfused for 15 min with  $10^{-5}$  M-nicotine (Nic). Recovery after removal of the nicotine took 2 hr. All concentrations in M.

considerably. The predominantly inhibitory actions of high concentrations of tubocurarine could be blocked by previous treatment of the heart with benzoquinonium, which often revealed an underlying excitation. Treatment of the heart with nicotine ( $10^{-5}$  M) also prevented the inhibitory action of tubocurarine on some preparations (Fig. 8), though the sensitivity to acetylcholine was not appreciably altered. Welsh & Taub (1953) have previously described an acetylcholine-blocking action of high concentrations of nicotine and this would appear to be related to the present findings. When the acetylcholine-blocking action of tubocurarine was studied, the concentration of antagonist had to be such that it had no effect when applied by itself. The concentration of tubocurarine used to antagonize acetylcholine was between  $10^{-7}$  and  $10^{-6}$  M, and failed to prevent the inhibitory action of acetylcholine.

Hexamethonium and decamethonium block cholinergic transmission at vertebrate autonomic ganglia and neuromuscular junctions respectively and might have been expected to provide some information about the nature of the receptor mechanism on the *Tapes* heart. However, neither compound had any antiacetylcholine action at concentrations of  $10^{-5}$  M. A similar lack of effect has been reported for pentamethonium and decamethonium on *Venus* heart (Welsh & Taub, 1953).

Several other substances with antiacetylcholine properties, including a group with atropine-like actions which has been used as antiParkinsonian drugs (caramiphen, benactyzine, procyclidine and trasentin) were tested on the heart at concentrations of  $10^{-5}$  M; none of these possessed any anticholinergic activity.

#### *Responses to catechol amines and histamine*

Diverse effects of adrenaline and noradrenaline on molluscan hearts, including excitation, inhibition or both, have been reported (Prosser, 1940; Welsh, 1953; Gaddum & Paasonen,



1955; Krijgsman & Divaris, 1955; Fänge, 1962; Greenberg, 1960a), and variable effects of these compounds and of dopamine (3,4-dihydroxyphenylethylamine) on the *Tapes* heart were observed during the present experiments. The most usual type of response was an increase in the amplitude and frequency of systolic contractions.

Dopamine was the most potent of the three compounds, having a threshold concentration for excitation of about  $10^{-7}$  M. Higher concentrations had variable effects (Fig. 9)

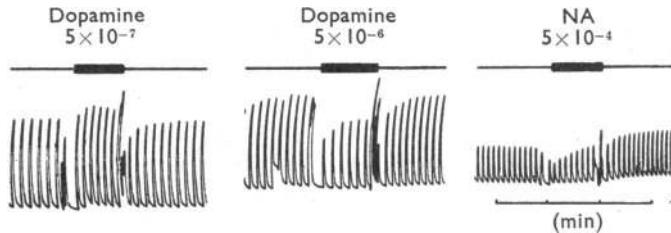

Fig. 9. Effects of dopamine and noradrenaline (NA). Dopamine ( $5 \times 10^{-7}$  M) excited the heart, but at a higher concentration it inhibited. Noradrenaline ( $5 \times 10^{-4}$  M) inhibited during the period of application with an excitation after washing. All concentrations in M.

which ranged from arrest of the heart in diastole to great excitation. Noradrenaline though about one-hundredth as potent as dopamine displayed a similar range of actions, weak excitation being apparent with concentrations of  $10^{-5}$  M and either excitation or inhibition followed by excitation (Fig. 9) with higher concentrations. The excitant potency of adrenaline was intermediate between those of dopamine and noradrenaline and it appeared to be less prone to reduce the amplitude of contraction. These effects of adrenaline on the *Tapes* heart are similar to those described by Ladd & Thorburn (1955), and the excitatory actions of the group are similar to those evinced on *Venus* hearts (Prosser, 1940; Welsh, 1953; Greenberg, 1960a). Greenberg (1960a) has also described an inhibitory action of dopamine on the *Venus* heart.

Repeated application of high concentrations of the catechol amines caused a considerable and often irreversible deterioration in the amplitude of cardiac contractions. This effect made it difficult to compare the actions of a series of concentrations of the three compounds. The excitant action of dopamine on the *Tapes* heart was unaffected by concentrations of methysergide sufficient to prevent the action of comparable concentrations of 5-hydroxytryptamine.

Histamine was without effect on the *Tapes* heart at a concentration of  $10^{-4}$  M, and at  $10^{-3}$  M caused an increase in the amplitude of contraction and a rise in baseline tone. Histamine occasionally acts on other molluscan hearts when applied at high concentrations causing either excitation or inhibition (Pilgrim, 1954; Gaddum & Paasonen, 1955; Greenberg, 1960a).

#### *Tryptamine analogues on the Tapes heart*

5-Hydroxytryptamine has a stimulant action on the isolated hearts of several molluscan species (Erspamer & Ghiretti, 1951; Welsh, 1953; Gaddum & Paasonen, 1955; Greenberg, 1960a, b) and it has been suggested that it is the transmitter released by the cardio-

acceleratory nerves in *Venus mercenaria* (Welsh, 1953; Loveland, 1963). 5-Hydroxytryptamine increased the amplitude and frequency of the systolic contractions of the *Venus* heart, and at high concentrations it may augment the tone (Welsh, 1953; Greenberg, 1960a, b).

5-Hydroxytryptamine had a similar action on the *Tapes* heart (Fig. 10), though the threshold concentration for excitation,  $10^{-8}$  M, compared unfavourably with that of  $10^{-10}$

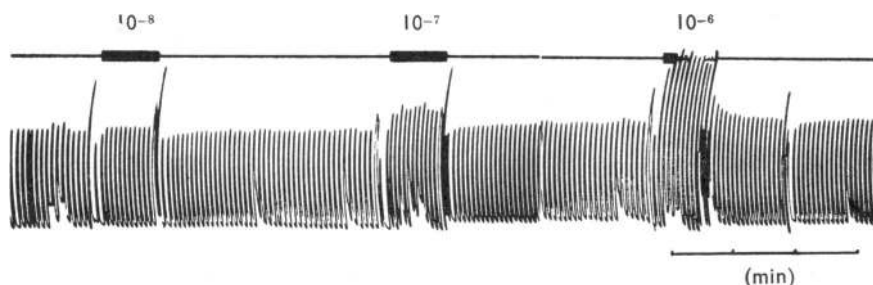

Fig. 10. The action of 5-hydroxytryptamine on the *Tapes* heart. Concentrations in M.

to  $10^{-9}$  M for *Venus* heart. A typical sigmoid dose/response curve for 5-hydroxytryptamine on the *Tapes* heart is illustrated in Fig. 11 and is comparable with the dose/response curves for this substance on the *Venus* heart (Greenberg, 1960b). 5-Hydroxytryptamine has been extremely valuable as an initiator of activity in hearts which failed to beat when first set up, a short application of  $10^{-7}$  to  $10^{-6}$  M-5-hydroxytryptamine being sufficient to induce activity which usually continued after removal of the drug solution.

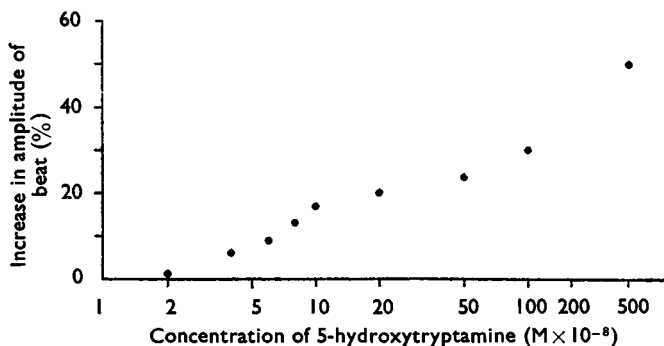

Fig. 11. Concentration/response curve for 5-hydroxytryptamine.

Tryptamine and a number of its analogues have been tested on the *Tapes* heart and their potencies compared with that of 5-hydroxytryptamine (Table 3). Drugs were applied for 1 min periods and the molar concentrations of each substance which caused a similar increase in the amplitude of contractions to that produced by a given concentration of 5-hydroxytryptamine were estimated. With the exception of bufotenine, all the compounds tested had a similar aminoethyl side chain ( $-\text{CH}_2-\text{CH}_2-\text{NH}_2$ ) attached at position 3, but differed in the groups attached at positions 2, 4, 5, 6 and 7 of the tryptamine

TABLE 3  
RELATIVE POTENCIES OF TRYPTAMINE ANALOGUES ON THE TAPES HEART

Compound	Relative concentrations (M) which caused a similar increase in beat amplitude
Tryptamine hydrochloride	13
4-Hydroxytryptamine oxalate	100
5-Hydroxytryptamine creatinine sulphate	1
6-Hydroxytryptamine creatinine sulphate	35
7-Hydroxytryptamine oxalate	150
5-Methoxytryptamine hydrochloride	7
6-Methoxytryptamine hydrochloride	Nil at $10^{-5}$ M
5,6-Methoxytryptamine hydrochloride	350
Bufotenine bioxalate	1
2-Methyl-5-chlor-tryptamine hydrochloride	Weak inhibition
5-Hydroxyindol-3-ylacetic acid	Nil at $10^{-6}$ M

molecule. Bufotenine carries two substituent methyl groups on the amino nitrogen atom of the side-chain  $[-CH_2-CH_2N(CH_3)_2]$ .

The results of the present investigations therefore supplement those that had previously been obtained on the *Venus* heart (Greenberg, 1960b) in which substitutions in the side-chain at position 3 provided most of the structural differences. The importance of the group attached at position 5 can readily be gauged from the high potencies of 5-hydroxytryptamine, bufotenine and 5-methoxytryptamine.

#### Derivatives of lysergic acid

Ergot alkaloids have a remarkable prolonged excitatory action on the heart of *Venus mercenaria* (Welsh & Taub, 1948; Wright *et al.*, 1962) and a similar action on the *Tapes* heart has been recorded by Ladd & Thorburn (1955). Two of the synthetic derivatives of lysergic acid, methysergide and 2-bromolysergic acid diethylamide have been reported as having minimal excitant actions on the *Venus* heart whilst effectively preventing the excitant action of 5-hydroxytryptamine. Methysergide, the more active antagonist, will also block the powerful excitant action of lysergide (lysergic acid diethylamide) on the *Venus* heart (Wright *et al.*, 1962). Lysergide is the most potent excitant agent of the *Venus* heart known. At a concentration of  $10^{-16}$  M it caused a maximal increase in the amplitude of the beat of over half of eighty hearts when allowed to act for 1 to 4 hr (Wright *et al.*, 1962).

Since the effects produced by prolonged exposure to these lysergic acid derivatives are largely irreversible, the contact time was restricted to 1 min. It has, however, been confirmed that lysergide (Fig. 12), ergotamine, ergotoxine and methylergometrine have powerful, prolonged excitant actions on the *Tapes* heart when applied for brief periods at concentrations of  $10^{-8}$  to  $10^{-7}$  M.

Methysergide was the least potent excitant of the group and proved to be an effective antagonist of 5-hydroxytryptamine. At the highest concentrations used ( $10^{-5}$  M) methysergide had little consistent action on the amplitude of the beat. Its effectiveness as an antagonist of 5-hydroxytryptamine and lysergide is illustrated in Fig. 12. The responses to the two drugs were still considerably reduced several hours after removal of methysergide from the perfusing solution.

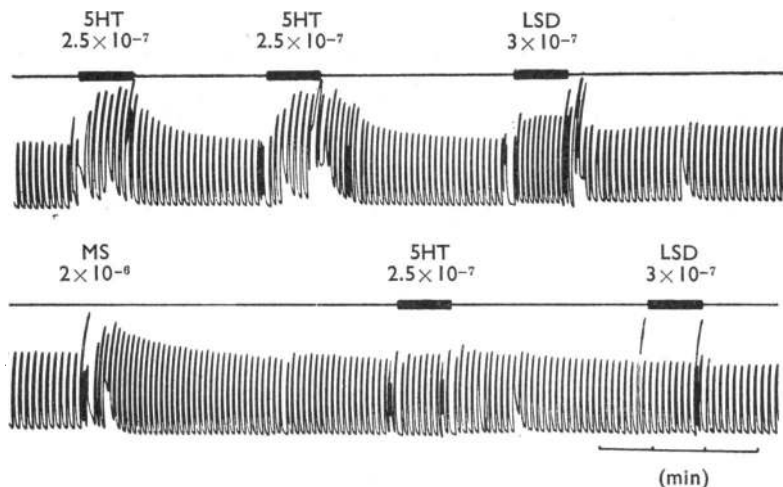

Fig. 12. Antagonism of the excitant actions of 5-hydroxytryptamine (5HT) and lysergide (LSD) by methysergide (MS). All concentrations in M.

#### *Observations on the pharmacology of the Tapes rectum*

During the course of the previous experiments, it became clear from a comparison of the results with preparations in which the rectum was still present with those from which the gut had been removed, that many of the compounds tested had actions on this structure. Experiments on the isolated rectum have confirmed this conclusion and the actions of some of the more important compounds will be described briefly.

Acetylcholine had a dual action on the *Tapes* rectum. At low concentrations ( $10^{-8}$  to  $10^{-7}$  M) it inhibited both the amplitude and frequency of the beat of spontaneously

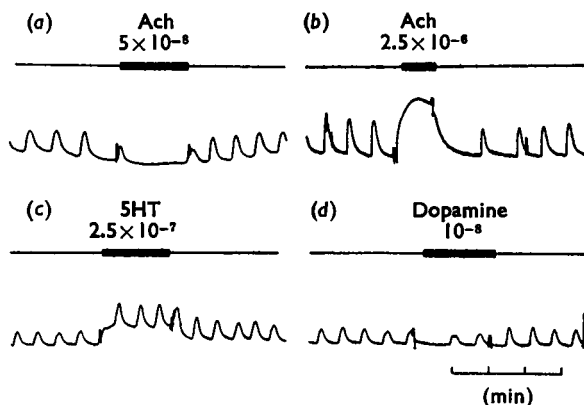

Fig. 13. Recordings from a spontaneously beating *Tapes* rectum. Acetylcholine (Ach,  $5 \times 10^{-8}$  M) inhibited the beat (a) and at higher concentrations it caused a tonic contraction of the rectum (b). 5-Hydroxytryptamine (5HT) augmented (c) the amplitude of the spontaneous contractions and caused a rise in tone, whilst dopamine ( $10^{-8}$  M) inhibited the amplitude and frequency of beats (d). Amplification on the Polygraph was approximately five times greater than when used to record cardiac contractions. All concentrations in M.

active preparations (Fig. 13,a). Higher concentrations ( $10^{-6}$  to  $10^{-5}$  M) caused the level of rectal tone to increase (Fig. 13,b).

5-Hydroxytryptamine excited the rectum. Low doses ( $10^{-8}$  M) often induced a fairly regular beat in quiescent preparations and higher concentrations caused an increase in tone (Fig. 13,c). Adrenaline ( $10^{-5}$  to  $10^{-3}$  M) produced an increase in tension of the preparation, which was often associated with a reduction in the frequency and amplitude of contractions in spontaneously active preparations; lower concentrations sometimes induced rhythmical activity in previously quiescent preparations. Dopamine and noradrenaline each had predominantly inhibitory actions on the *Tapes* rectum, reducing the activity of spontaneously beating recti and decreasing the magnitude of the tension changes induced by 5-hydroxytryptamine. This action of dopamine is illustrated in Fig. 13,d, and on this preparation higher concentrations of dopamine induced a prolonged (30 min) reduction in spontaneous activity. Noradrenaline had a similar inhibitory action, though its potency was 10- to 100-times less than that of dopamine. Both compounds caused small increases in tension when applied at high concentrations.

#### DISCUSSION

Our studies were undertaken to investigate the pharmacological responses of the isolated heart of *Tapes watlingi* and so to define its suitability for the bioassay of acetylcholine and 5-hydroxytryptamine. This mollusc is a member of the same family, Veneridae, as the American clam, *Venus mercenaria*, the heart of which has been extensively investigated pharmacologically since Prosser & Prosser (1937) initially described its extreme sensitivity to inhibition by acetylcholine.

The pharmacological specificity of the receptors on the *Tapes* heart has been shown to resemble closely that of the receptors on the *Venus* heart, and the two preparations are obviously very similar. Acetylcholine inhibits the *Tapes* heart in concentrations which are comparable with those required for inhibition of the *Venus* heart. This action can be prevented by treatment of the heart with benzoquinonium, a curare-like drug (Hoppe, 1950) which is also the most active antagonist of acetylcholine on the *Venus* heart. After antagonism by benzoquinonium, acetylcholine has an excitant action, which occurs at concentrations as low as  $10^{-9}$  M. A weak excitant action of acetylcholine in concentrations which are subthreshold for inhibition has also been observed with both the *Tapes* and *Venus* hearts, and Welsh & Taub (1948) suggested that this compound might have a dual action on the *Venus* heart. However, the powerful excitant action of acetylcholine which occurs after treatment with benzoquinonium does not appear to have been observed on the *Venus* heart. It seems strange that activity can be reinitiated in a benzoquinonium-treated heart which has failed to beat by the application of acetylcholine. An excitant action of propionylcholine, butyrylcholine and arecoline was also observed on the benzoquinonium-treated heart and it is interesting to note that their excitant potencies more closely approached that of acetylcholine than did their inhibitory actions.

Tetramethylammonium ions, which inhibit the *Venus* heart, had an excitant action on the *Tapes* preparation comparable with that due to tetraethylammonium ions. Nicotine had a dual action on the heart with excitation predominating, whereas on the *Venus* heart it has an inhibitory action at similar concentrations (Welsh & Taub, 1953). Tubocurarine also had mixed effects on the *Tapes* heart, those illustrated in Fig. 7 being fairly

typical. The inhibitory action of this substance was reduced both by benzoquinonium and by nicotine.

Atropine had little antiacetylcholine activity on the majority of preparations, a finding which conforms with those from the *Venus* heart. On two preparations, however,  $10^{-7}$  M-atropine abolished the inhibitory action of acetylcholine. Welsh & Taub (1953) have already concluded that the acetylcholine receptor on the *Venus* heart differs from that at the better known sites of action of this substance in vertebrates, for example, synapses in the autonomic nervous system and at the neuromuscular junction, and this conclusion also applies to the receptor on the *Tapes* heart. It remains to be established whether the few differences described between the hearts of the two species are genuine or merely the result of differences in technique. It has generally been assumed that acetylcholine is the likely cardioinhibitory transmitter at the *Venus* heart (Prosser, 1940), though the evidence for this is not conclusive and, since other types of cholinester occur in molluscs (Whittaker, 1960), this issue might well be re-examined.

The exact mechanism of cardiac excitation, inhibition and conduction is not understood, and classically, molluscan hearts, as opposed to those of arthropods, are considered to be largely myogenic. The literature records contradictory findings concerning the question of nervous elements in the heart, and in a recent review (Krijgsman & Divaris, 1955) it was concluded that histological evidence does not support the concept of a neurogenic pacemaker, though in some species neurones were observed. Our results suggest that there may be two types of acetylcholine receptor; one mediating the cardio-inhibitory effects of ganglionic activity, and the other of uncertain function. The considerable excitant action of benzoquinonium on many of the hearts is difficult to explain unless it is assumed that there is a continuous release of acetylcholine or a related compound from nerve endings in the heart. Further histological studies will be required to determine whether these terminals are those of the ganglionic fibres or whether they arise from cells within the heart. Welsh (1953) has reported that the inhibition of cardiac contractions which occurs during stimulation of the visceral ganglion is replaced by excitation when the heart is perfused with solution containing benzoquinonium. It was suggested that this result was due to the continued release of cardioexcitatory transmitter, 5-hydroxytryptamine, now no longer opposed by inhibition. In the light of our results, it is also possible that the excitation was due to an unmasked excitant action of acetylcholine.

Evidence for the role of 5-hydroxytryptamine as the cardioexcitatory transmitter on *Venus mercenaria* has recently been discussed (Loveland, 1963) and in view of the similarity of the responses of the *Tapes* heart to tryptaminergic compounds it appears likely that 5-hydroxytryptamine may have a similar role in this species. The *Tapes* heart appears to be 10- to 100-times less sensitive to 5-hydroxytryptamine than is the *Venus* preparation on the basis of our results. It must, however, be emphasized that Greenberg (1960b) allowed the drug to act until no further change occurred in the magnitude of cardiac contractions and that this technical difference could be the reason for the lower activity observed in our experiments. In biological tests for the release of acetylcholine from the central nervous system (Phillis & Chong, 1965) we have found that the presence of small amounts of blood or of tissue damage is associated with the release of sufficient 5-hydroxytryptamine (presumably from platelets) to mask any inhibitory action. It was therefore essential first to treat the heart with methysergide.

The presence of the intestine in preparations used for bioassay does not appear significantly to distort the results. High concentrations of acetylcholine, 5-hydroxytryptamine, adrenaline, noradrenaline and dopamine all cause an increase in rectal tone which is evident on the records from the cardio-rectal preparation. The concentrations required to produce these effects are, however, much higher than those which have actions on the ventricular muscle. Perhaps the most irritating feature of the rectum is its predisposition to periodic contractures, an occurrence which is more frequent in molluscs that have been maintained in the laboratory for some weeks. This type of distortion of the recording can readily be eliminated by incising the ventricular wall and cutting the rectum.

## SUMMARY

1. The effects of various drugs on the isolated heart of the marine mollusc, *Tapes watlingi*, are described.
2. Acetylcholine inhibits the heart; the threshold concentration being about  $5 \times 10^{-10}$  M. This effect can be abolished by prior perfusion of the heart with benzoquinonium, after which drug acetylcholine has an excitant action on the heart.
3. A comparison of the estimates of relative inhibitory potency of a series of compounds which act on acetylcholine receptors reveals that the heart is specifically sensitive to acetylcholine.
4. Dopamine and noradrenaline have both excitant and inhibitory effects on the heart. Adrenaline has a predominantly excitant action.
5. A number of tryptamine analogues have been tested on the heart. Most of these have an excitant action, 5-hydroxytryptamine and bufotenine being the most potent with a threshold concentration about  $10^{-8}$  M.
6. Lysergic acid derivatives had an excitant action on the heart. This was least pronounced with methysergide which was the most potent antagonist of excitation due to 5-hydroxytryptamine and lysergide.
7. In its responses to the compounds tested the *Tapes* heart has displayed a marked similarity to the *Venus mercenaria* heart preparation.
8. Some preliminary observations on the pharmacological responses of the rectum of *Tapes watlingi* are reported.

The following drugs were donated by the individuals or firms quoted and for these we are very grateful. Dr A. Cerletti and Dr G. Etter (Sandoz): 4-, 6- and 7-hydroxytryptamine, bufotenine, (+)-lysergic acid diethylamide, methysergide and 1-methylergometrine; Dr G. Deffenu (Farmitalia, Milan): 5-, 6- and 5,6-methoxytryptamine and 5-chlor-2-methyltryptamine; Sterling-Winthrop Research Institute: benzoquinonium (Mytolon); Merck Sharp & Dohme: dihydro- $\beta$ -erythroidine and mecamlamine hydrochloride; Geigy Pharmaceutical Co.: caramiphen hydrochloride (Parpanit); May & Baker: gallamine triethiodide (Flaxedil); Burroughs Wellcome: procyclidine hydrochloride (Kemadrin); Ciba Laboratories: trasentin hydrochloride; Glaxo-Allenburys: benactyzine hydrochloride.

It is a pleasure to acknowledge the technical assistance of Miss G. Thornell. G.C.C. was a National Heart Foundation of Australia Medical Research Scholar.

## REFERENCES

- ERSPAMER, V. & GHIRETTI, F. (1951). The action of enteramine on the heart of molluscs. *J. Physiol. (Lond.)*, **115**, 470-481.
- FÄNGE, R. (1962). Pharmacology of poikilothermic vertebrates and invertebrates. *Pharmacol. Rev.*, **14**, 281-316.

- GADDUM, J. H. & PAASONEN, M. K. (1955). The use of some molluscan hearts for the estimation of 5-hydroxytryptamine. *Brit. J. Pharmacol.*, **10**, 474-483.
- GREENBERG, M. J. (1960a). The responses of the *Venus* heart to catechol amines and high concentrations of 5-hydroxytryptamine. *Brit. J. Pharmacol.*, **15**, 365-374.
- GREENBERG, M. J. (1960b). Structure-activity relationship of tryptamine analogues on the heart of *Venus mercenaria*. *Brit. J. Pharmacol.*, **15**, 375-388.
- HOPPE, J. O. (1950). Pharmacological investigation of 2,5-bis-(3-diethylaminopropylamino)benzoquinone-bis-benzyl chloride (Win 2747): a new curarimetic drug. *J. Pharmacol. exp. Ther.*, **100**, 333-345.
- IREDALE, T. (1958). Some molluscan name changes. *Proc. roy. Zool. Soc. (N.S.W.)*, 1956-1957, 103-104.
- KRIGSMAN, B. J. & DIVARIS, G. A. (1955). Contractile and pacemaker mechanisms of the heart of molluscs. *Biol. Rev.*, **30**, 1-39.
- LADD, R. J. & THORBURN, G. D. (1955). New test animal for acetylcholine assay. *Aust. J. exp. Biol. med. Sci.*, **33**, 207-214.
- LOVELAND, R. E. (1963). 5-Hydroxytryptamine, the probable mediator of excitation in the heart of *Mercenaria (Venus) mercenaria*. *Comp. Biochem. Physiol.*, **9**, 95-104.
- LUDUEÑA, F. P. & BROWN, T. G. (1952). Mytolon and related compounds as antagonists of acetylcholine on the heart of *Venus mercenaria*. *J. Pharmacol. exp. Ther.*, **105**, 232-239.
- PHILLIS, J. W. & CHONG, G. C. (1965). Acetylcholine release from the cerebral and cerebellar cortices: its role in cortical arousal. *Nature (Lond.)*, in the press.
- PILGRIM, R. L. C. (1954). The action of histamine on the hearts of two lamellibranch molluscs. *J. Physiol. (Lond.)*, **126**, 619-622.
- PROSSER, C. L. (1940). Acetylcholine and nervous inhibition in the heart of *Venus mercenaria*. *Biol. Bull.*, **78**, 92-102.
- PROSSER, C. L. & PROSSER, H. B. (1937). The action of acetylcholine and of inhibitory nerves upon the heart of *Venus*. *Anat. Rec.*, **70**, suppl. 1, 112.
- SMITH, C. C. & LEVIN, L. (1938). The use of the clam heart as a test object for acetylcholine. *Biol. Bull.*, **75**, 365.
- TOWER, D. B. & MCEACHERN, D. (1948). Experiences with the 'Venus' heart method for determining acetylcholine. *Canad. J. Res.*, **E**, **26**, 183-187.
- WAIT, R. B. (1943). The action of acetylcholine on the isolated heart of *Venus mercenaria*. *Biol. Bull.*, **84**, 79-85.
- WELSH, J. H. (1953). Excitation of the heart of *Venus mercenaria*. *Naunyn-Schmidzberg's Arch. exp. Path. Pharmacol.*, **219**, 23-29.
- WELSH, J. H. & MOORHEAD, M. (1959). Identification and assay of 5-hydroxytryptamine in molluscan tissues by fluorescence method. *Science*, **129**, 1491-1492.
- WELSH, J. H. & SLOCOMBE, A. G. (1952). The mechanisms of action of acetylcholine on the *Venus* heart. *Biol. Bull.*, **102**, 48-57.
- WELSH, J. H. & TAUB, R. (1948). The action of choline and related compounds on the heart of *Venus mercenaria*. *Biol. Bull.*, **95**, 346-353.
- WELSH, J. H. & TAUB, R. (1950). Structure-activity relationships of acetylcholine and quaternary ammonium ions. *J. Pharmacol. exp. Ther.*, **99**, 334-342.
- WELSH, J. H. & TAUB, R. (1953). The action of acetylcholine antagonists on the heart of *Venus mercenaria*. *Brit. J. Pharmacol.*, **8**, 327-333.
- WHITTAKER, V. P. (1960). Pharmacologically active choline esters in marine gastropods. *Ann. N.Y. Acad. Sci.*, **90**, 695-705.
- WRIGHT, A. M., MOORHEAD, M. & WELSH, J. H. (1962). Actions of derivatives of lysergic acid on the heart of *Venus mercenaria*. *Brit. J. Pharmacol.*, **18**, 440-450.