

Phase and Antigenic Variation in Bacteria

Marjan W. van der Woude^{1*} and Andreas J. Bäuml²

*Department of Microbiology, School of Medicine, University of Pennsylvania, Philadelphia, Pennsylvania 19104-6076¹ and
Department of Medical Microbiology and Immunology, College of Medicine, Texas A & M University
System Health Science Center, College Station, Texas 77843-1114²*

INTRODUCTION	581
PHASE-VARIABLE PHENOTYPES AND MOIETIES	582
Colony Morphology and Opacity	582
Capsule	583
Fimbriae and Pili	584
Flagella	584
Other Surface-Exposed Proteins	584
LPS and LOS Modification: Variation in Expression of Surface Epitopes	585
DNA Restriction-Modification Systems	586
Regulatory Proteins	586
Metabolism-Associated Genes	586
Phage Genes	587
Concluding Remarks	587
MOLECULAR MECHANISMS OF PHASE VARIATION	587
Genetic Regulation	587
Short sequence repeats and slipped-strand mispairing	587
Homologous (general) recombination	589
Site-specific recombination	591
(i) Inversion of a DNA element by CSSR	591
(ii) Insertion and excision of genetic elements from the chromosome	593
Epigenetic Regulation	594
PAP phase variation	594
Ag43 phase variation	595
Phase Variation as Part of the Cell's Regulatory Network	596
Cross regulation	596
Environmental regulation	596
Concluding Remarks	597
GENOMICS AND PHASE VARIATION	597
BIOLOGICAL SIGNIFICANCE OF PHASE VARIATION	598
Persistence through Surface Variation	598
Evasion of Cross-Immunity	600
DNA Restriction-Modification Systems	601
DIAGNOSTIC AND EXPERIMENTAL SIGNIFICANCE OF PHASE VARIATION	601
ACKNOWLEDGMENTS	602
REFERENCES	602

INTRODUCTION

Phenotypic variation in bacteria has long been recognized and has been a focus of study mainly in bacterial pathogens. This interest has been fueled by the observation that phenotypic variation in pathogens, most readily visible as colony variation, is often associated with the virulence of the strain. Alternating between two phenotypes in a heritable and reversible manner can be classified as phase variation or antigenic variation. These terms, phase variation and antigenic variation, however, have been used in various ways. Phase variation in general refers to a reversible switch between an “all-or-none”

(on/off) expressing phase, resulting in variation in the level of expression of one or more proteins between individual cells of a clonal population. What distinguishes this variation from genetic noise and classical gene regulation is that there is a genetic or epigenetic mechanism that allows the variability to be heritable. This means that a daughter cell will inherit the expression phase of the parent. However, the phase of expression must also be reversible between generations, and the frequency of this reversion should exceed that of a random mutation. Thus, in a clonal population after cell division, the majority of daughter cells will retain the expression phase of the parent but a minority will have switched expression phase. The switch is a stochastic event, even though the chance that it occurs in some cases can be influenced by external factors; in other words, the switching frequency can be modulated. The frequency with which this occurs is characteristic for the gene, the bacterial species, and the regulatory mechanism. This can

* Corresponding author. Mailing address: Department of Microbiology, University of Pennsylvania, 202A Johnson Pavilion, 3610 Hamilton Walk, Philadelphia, PA 19104-6076. Phone: (215) 573-4104. Fax: (215) 573-4184. E-mail mvdwoude@mail.med.upenn.edu.

be as high as a change in 1 cell per 10 per generation but more often is on the order of 1 change per 10^3 cells per generation. The term "phase variation" is used in other contexts as well, describing phenotypic "phase variants" of a species in which the change is irreversible or variants that are a result of environmental regulation, selection, or unidirectional mutation. In this review, however, we adhere to the definition in the sense that the expression phase must be inherited by a genetic or epigenetic mechanism and that this change must be reversible. The actual switching frequencies are not reported here, because the methods that are used to determine them vary significantly and because they can be modulated by growth conditions. Differences are therefore difficult to interpret.

Antigenic variation refers to the expression of functionally conserved moieties within a clonal population that are antigenically distinct. The genetic information for producing a family of antigenic variants is available in the cell, but only one variant is expressed at a given time. In an excellent chapter on antigenic variation in bacteria, Barbour listed three criteria that must be fulfilled for variation to be considered as antigenic variation (12). These are (i) that the antigenic change must be involved in avoidance of immune or niche selection, (ii) that it is a multiphasic change, and (iii) that the mechanism is consistent with gene conversion. In this review, the term is used in a broader sense, including biphasic variation, antigenic variation for which the biological significance is not clear, and modification of the antigenic identity of a cell surface structure as a result of a phase-varying enzyme. Antigenic variation in eukaryotic pathogens, including *Plasmodium falciparum* and African trypanosomes, is not addressed here but is discussed in recent reviews (15, 37, 70, 77, 217, 358).

We will refer the reader to reviews that present in-depth discussions on specific topics relating to phase and antigenic variation, where relevant. These focus, for example, on a single bacterial species, regulatory mechanism, or biological role (29–31, 68, 85, 119, 127, 140, 160, 177, 364, 368, 410). In this review, we hope to provide the reader with awareness and basic understanding of the prevalence, mechanisms, and significance of phase variation in bacteria, with an emphasis on recent developments and insights.

PHASE-VARIABLE PHENOTYPES AND MOIETIES

The classical view of phase variation and antigenic variation is that its role is to help the bacterium evade the host immune system. This seemed to be supported by the fact that the structures that were found to phase vary were on the cell surface, where they would be exposed to the immune system. From the examples discussed below and those presented in Table 1, it is evident that the majority of identified phase-variable moieties are indeed on the surface and exposed to the environment. However, some variation occurs for which there is no evidence of association with changes in the cell surface, such as phase variation of DNA modification. Furthermore, from Table 1, it is clear that in some bacterial species many more loci have been identified that are under the control of phase or antigenic variation than in other species. Below, both well-studied and less well-studied examples are described that illustrate the diversity in moieties affected and species in which phase and antigenic variation have been identified. References

are provided for systems that are not described in detail but may be of interest to the reader, and, where relevant, we refer the reader to Table 1 or other sections of this review where additional aspects of the system are discussed.

Colony Morphology and Opacity

Historically, phase-variable structures have been recognized by their effect on colony morphology that led to descriptions like dry versus moist, ruffled versus smooth, and opaque versus translucent. These changes in colony morphology can be attributed to phase variation of a variety of surface-exposed proteins, of the capsule, and of cell wall composition. These changes most probably lead to altered packing of cells in the colony, which determines the colony morphology. This relationship was directly shown for *Vibrio parahaemolyticus* with variable levels of capsule production (92).

In *Haemophilus influenzae* type b strains, three colony variants, opaque, intermediate, and translucent, have been found. These vary in important virulence properties like colonization in the nasopharynx and serum resistance. The colony phenotype appears to be a result of specific combinations of expression of multiple phase-variable proteins, which include variation in the level of capsule production and in the level of a cell envelope protein encoded by *oapA* (244, 281, 296, 388) (Table 1). A clear relation between colony phenotype and colonization or virulence also exists in *Streptococcus pneumoniae* (172, 387). In an animal model, opaque variants were more virulent on systemic infection whereas the translucent variants were more successful colonizers of the nasopharynx. The two variants also differed in an in vitro assay of invasion and transcytosis of endothelial cells. Opaque variants produced up to sixfold more capsule and twofold less teichoic acid compared to the transparent form (292). Similarly, *Streptococcus gordonii* colony morphology and virulence-associated properties, including hemolysin production, phase vary (163, 374). In contrast, in *Helicobacter pylori*, a variable-colony phenotype is a result of phase variation of expression of phospholipase A, which indirectly affects virulence by release of urease and VacA (347, 348) (Table 1). In the pathogen *Salmonella enterica* serotype Typhimurium, variable colony morphology is correlated with the coordinated control of phase variation of at least four proteins (153). However, the soil isolate *Pseudomonas aeruginosa* also showed variable colony morphology, which was correlated with phase variation of multiple traits including aggregation and motility (71).

Color variation in colonies grown on specific media can be caused by phase variation of proteins that interact with a dye. For example, in certain strains of *Staphylococcus epidermidis*, phase variation of a polysaccharide adhesin leads to variable colony color when grown on Congo red agar (419, 420) (Table 1; also see "Molecular mechanisms of phase variation" below). In summary, any reversible change in colony morphology, opacity, or color indicates that the expression of one or more proteins phase varies. Further analysis of these and related phenotypic variations may provide us with new insights into bacterial survival strategies, and the strong correlation between virulence and colony morphology in pathogens suggests that characterizing the underlying molecular basis may also provide valuable insights into bacterial pathogenesis.

TABLE 1. Representative selection of bacterial species in which phase and/or antigenic variation occurs^a

Bacterial species	Affected moiety or phenotype ^b	Gene(s) or operon regulated	Variation of regulated gene(s) ^c	Class(es) of regulated gene or operon	Molecular mechanism	Reference(s) ^d
<i>Bordetella pertussis</i>	Fimbriae	<i>fim3, fim3</i>	Phase	Structural	SSM ^e	400
	Multiple virulence factors	<i>bvgS</i>	Phase	Regulatory	SSM	340
<i>Borrelia burgdorferi</i>	Lipoprotein	<i>vlsE</i>	Antigenic	Structural	Recombination ^f	181, 232, 411
<i>Campylobacter coli</i> ^g	Flagella	<i>flhA</i>	Phase	Regulatory	SSM	272
<i>Campylobacter fetus</i> ^g	SLP	<i>sapA</i>	Antigenic	Structural	Recombination ^f	81, 82, 286
<i>Campylobacter jejuni</i> ^g	LOS modification ^h	<i>wlaN, cgtA</i>	Phase	Enzyme	SSM	105, 111, 206
	Flagella	<i>maf1</i>	Phase	Unknown function	SSM	41, 169
<i>Escherichia coli</i>	Fimbriae (type 1, CS18)	<i>fim, fot</i> operons	Phase ^e	Structural, regulatory ⁱ	CSSR ^j	1, 29, 31, 135
	Fimbriae (Pap, S, F1845, Clp)	<i>pap</i> and family of <i>pap</i> -like operons (<i>sfa, daa, clp</i>)	Phase ^e	Structural, regulatory ⁱ	DNA methylation ^k	40, 128, 129, 224, 371
<i>Haemophilus influenzae</i> ^g	Outer membrane protein	<i>agn43 (flu)</i>	Phase	Structural	DNA methylation ^k	116, 126
	LOS modification ^h		Phase	Enzyme	SSM	
	ChoP	<i>lic1A</i>				390
	Neu5Ac	<i>lic3A</i>				137, 141
	Other	<i>lic2A, lgtC</i>				131, 132, 137
<i>Helicobacter pylori</i> ^g	DNA modification	<i>mod</i>	Phase	Enzyme	SSM	66
	Fimbriae LKP	<i>hifA, hifB</i>	Phase	Structural	SSM	372
	DNA R/M	<i>mod</i>	Phase	enzyme	SSM	70
	LPS modification (Lewis antigen) ^h	<i>futA, futB, futC</i>	Phase	Enzymes	SSM	241, 384, 385
	Flagella	<i>fliP</i>	Phase	Structural	SSM	165
<i>Moraxella catarrhalis</i>	Membrane lipid composition ^h	<i>pldA</i>	Phase	Enzyme	SSM	347
	Adhesin	<i>uspA1</i>	Phase	Structural	SSM	191
<i>N. gonorrhoeae</i> ^g	Type IV pilin modification ^h	<i>pgtA</i>	Phase	Enzyme	SSM	10
	Siderophore receptor	<i>fetA</i>	Phase	Structural	SSM	42
<i>N. meningitidis</i> ^g	Outer membrane protein	<i>porA</i>	Phase	Structural	SSM	365, 366
	Outer membrane protein	<i>opc</i>	Phase	Structural	SSM	305
	Hemoglobin receptors	<i>hpuAB, hmbR</i>	Phase	Structural	SSM	201
	Capsule	<i>siaD</i>	Phase	Enzyme	SSM	122
	Capsule	<i>siaA</i>	Phase	Enzyme	Transposition ^l	121
<i>N. gonorrhoeae</i> and <i>N. meningitidis</i>	Opacity proteins	<i>opa</i>	Phase	Structural	SSM	339
	Type IV pilin	<i>pilE, pilS</i>	Phase and antigenic	Structural	Recombination	118, 142, 247, 278, 317
	Adhesin, type IV pilus associated	<i>pilC</i>	Phase	Structural	SSM	164, 312
Commensal <i>Neisseria</i> spp.	LOS modification	<i>lgtA, C, lgtD</i>	Phase	Enzyme	SSM	157, 324, 404
	LPS modification ^h (ChoP)	<i>licA</i>	Phase	Enzyme	SSM	321, 322
<i>Proteus mirabilis</i>	Fimbriae (MR/P)	<i>mvp</i> operon	Phase ^e	Structural, regulatory ⁱ	CSSR	202, 416
<i>Salmonella enterica</i> serotype Typhimurium	Fimbriae (Pef)	<i>pef</i> operon	Phase ^e	Structural, regulatory ⁱ	DNA methylation	251
<i>Staphylococcus epidermidis</i>	Flagella	<i>fljBA, fljC</i>	Antigenic	Structural regulatory	CSSR	328
	Adhesin (polysaccharide)	<i>ica</i>	Phase	Structural	Transposition	419, 420
<i>Streptococcus pneumoniae</i>	Capsule	<i>cap3A</i>	Structural	Recombination	379	
	Metabolism	<i>spxB</i>	Phase	Enzyme	SSM	268, 275
	DNA R/M	DNA methylase	Phase	Enzyme	SSM	268, 275
<i>Streptococcus pyogenes</i>	Surface protein	<i>sclB</i>	Phase	Structural	SSM	285

^a Examples were chosen from well-studied systems that together illustrate the diversity of occurrence in species, the affected moiety or phenotype, the classes of proteins that the phase-varying genes encode, and the molecular mechanism involved. The table is not meant to be comprehensive. The text discusses additional examples not listed in the table.

^b Phase-variable expression, modification, or antigenic variation of the moiety is usually a direct effect of phase-variable expression of the associated gene. Indirect effects occur mostly when modification is at issue (see footnote *h*).

^c Classified as an on/off phase variation or altered antigenic properties of a constantly expressed moiety.

^d References are for key papers and reviews.

^e SSM results in variable numbers of DNA sequence repeat units that can affect transcription or translation (see the text and Fig. 1).

^f General recombination.

^g In this species, expression of additional proteins not listed here is predicted to phase vary by SSM based on genome sequence analysis (see "Genomics and phase variation").

^h Modification of the moiety that results in antigenic variation is caused by phase-variable expression of the gene, which affects (one of) the enzymatic steps leading to the modification.

ⁱ Expression of the entire operon, which consists of genes encoding proteins of multiple classes, phase varies.

^j CSSR causes inversion of a DNA element that contains the main promoter for the corresponding operon.

^k DNA methylation by the DNA maintenance methylase Dam.

^l Reversible insertion-excision of IS (like) element.

Capsule

The capsule can influence interactions with the host cells and host environment, including invasion, adhesion, and serum sensitivity, and is a well-recognized virulence factor. Phase variation of capsule synthesis can involve a classic on/off switch but also has been used to describe modulations in the level of

production; as mentioned above, this can change colony morphology. Capsule variation has been found to occur in both gram-positive and gram-negative bacterial species, including *Campylobacter jejuni* (9), *Citrobacter freundii* (267), *S. pneumoniae* (379), and specific serogroups of *Neisseria meningitidis* (121, 122) (Table 1). In *Bacteroides fragilis*, eight different cap-

sule polysaccharides can be produced per cell. The expression of each is under the control of on/off phase variation, resulting in a very diverse clonal population (183a). In *H. influenzae* type b cells, the level of expression of the capsule can be modulated, and an irreversible switch to a nonexpressing phenotype can occur (see the sections on recombination [below]) (reviewed in reference 297).

Fimbriae and Pili

Fimbriae, also referred to as pili, are proteinaceous structures that extend from the cell surface. Fimbriae assembled by the chaperone/usher-dependent and the nucleator/precipitation pathways are distinct in both structure and function from type IV pili (reviewed in references 96, 227, 306, and 381). Fimbriae mediate adhesion of the bacterial cell to host tissue through interaction with receptors located on the host cell (reviewed for *Escherichia coli* in reference 209). These interactions, which occur either with the main structural subunit or with a fimbrial adhesin, are often specific, so that certain chemical groups of the host proteins or lipids are recognized by the fimbrial adhesin. Fimbria-mediated attachment to inorganic, solid surfaces most probably occurs by nonspecific interactions, an important feature in biofilm formation (263, 282). Phase variation of fimbriae is regulated mostly by mechanisms that affect transcription originating at the major promoter of the operon, resulting in variable (on/off) expression of most or all genes in the fimbrial operon (209).

A single species, or even a single isolate, can express multiple fimbriae that each can phase vary. The genomes of different pathogenic *E. coli* isolates encode different fimbriae, some of which phase vary, as well as type 1 fimbriae, which is common to all isolates and which phase varies (Table 1). The *S. enterica* serotype Typhimurium genome encodes at least 11 fimbrial operons, among which phase-variable expression has been identified for *pef*, *lpf*, and *fim* (53, 146, 251, 256) (Table 1). The biological role of phase variation of fimbriae is discussed in "Biological significance of phase variation" (below).

Fimbrial phase variation control mechanisms and the fimbrial structural genes may have evolved as separate modules. For example, the common feature of the *pap*-like family of fimbrial operons is the regulatory mechanism of phase variation, but the fimbrial structural genes within this family are not all related. Conversely, the subunit of the MR/P fimbriae in *Proteus mirabilis* resembles that of Pap fimbriae in *E. coli*, but the two phase variation control mechanisms are different (128, 202) (see "Molecular mechanisms of phase variation" below) (Table 1).

Type IV pili function as adhesins and include conjugative pili. Phase variation, antigenic variation of the structural subunits, and phase-variable modification have been described. Sequence variation in the type IV conjugative pili encoded by plasmids R64, R721, and ColI-P9 occurs as a result of incorporation of only one of a set of distinct C termini in the PilV tip proteins of the pilus in an individual cell. This sequence variation is associated with different receptor specificity, thereby dictating the species that will be preferred as a DNA recipient in a conjugation reaction (154, 177, 178). *N. gonorrhoeae* can theoretically produce over a million different, antigenically distinct pilin subunits for its type IV pili (99, 180, 240, 319, 346;

reviewed in reference 12) (see "Molecular mechanisms of phase variation" below) (Table 1). In addition, the pilus-associated protein PilC phase varies (164) (Table 1). These pili are involved in interaction with eukaryotic cells, and thus these variations are probably important for pathogenesis (28, 312). In *S. enterica* serotype Typhi, phase-variable expression of the PilV subunit of the type IVB pili affects the pilus-associated property of cellular autoaggregation (243) (see "Molecular mechanisms of phase variation" below). Pili can also be modified, but whether modification occurs can vary within a clone, due to phase variation in the expression of one of the enzymes involved. This is the case for glycosylation by PgtA in *N. gonorrhoeae* (10) (Table 1).

Flagella

Flagella mediate bacterial motility; adhesion and virulence are sometimes enhanced by flagellar expression and motility (265). Flagellin is also a pathogen-associated molecular pattern recognized by the innate immune system through Toll-like receptor 5 (204). The antigenic property of the flagellin of a bacterial isolate forms a significant part of the serological classification scheme, indicating that this is, in general, an invariant property. However, phase and antigenic variation of flagella in a clonal population does occur. As early as 1922, variation of the flagellar antigens in *S. enterica* serotype Typhimurium was described by Andrewes (6). This consists of variation between two forms (biphasic antigenic variation), H1 and H2, in which the flagellar subunit consists of the FliC or FljB protein, respectively (35, 326) (see "Molecular mechanisms of phase variation" below). Mutants that no longer can switch between flagellar types were altered in virulence compared to the wild-type isolate (150), and the two flagellar subunits appear to elicit different responses from eukaryotic cells (46).

In *Campylobacter coli* (272), *Campylobacter jejuni* (106, 169), and *Helicobacter pylori* (264), flagellar expression and motility phase vary (41, 73, 165) (Table 1). The underlying reason for this can differ. For example, *C. coli* expression of FlhA, which is required for the expression of flagellin, phase varies (272), whereas in *H. pylori*, expression of the *fljP* gene, encoding the flagellar basal body, phase varies (165) (Table 1). In *Bordetella pertussis*, phase-variable expression of the regulatory system BvgAS results in flagellar phase variation (340) (Table 1) (see "Regulatory proteins" below). In this species, flagellar synthesis is not required for virulence and may even be detrimental (2).

Other Surface-Exposed Proteins

Proteins that are integrated in the cell wall in gram-positive organisms or in the outer membrane in gram-negative organisms can have a variety of functions; these proteins include transporters, porins, receptors, colonizing factors, and enzymes. Antigenic or phase variation has been found for at least one member of each of these functional groups (Table 1).

In the M1inv⁺ clone of the gram-positive group A *Streptococcus* (*S. pyogenes*), expression of the cell wall-associated surface proteins C5a peptidase, M protein, and type IIa IgG Fc receptor phase vary, as well as expression of the capsule and pyrogenic exotoxin (52, 195). This is in part due to phase-

variable expression of the DNA binding, regulatory protein Mga (see “Regulatory proteins” below) (36, 233–235, 329). Expression of the collagen-like surface protein SclB is under the control of a separate phase variation control mechanism (285) (see “Molecular mechanisms of phase variation” below) (Table 1).

In gram-negative *N. gonorrhoeae* and *N. meningitidis* strains, expression of various outer membrane proteins phase varies, including that of members of the family of outer membrane opacity proteins (*opa*) that facilitate adhesion (339) (see “Biological significance of phase variation” below) (Table 1) and the porin PorA (class I outer membrane protein) in serogroup B *N. meningitidis* (Table 1). PorA is one of the candidates for a protein-based vaccine, and phase variation, as well as the naturally occurring antigenic variation of this protein, may affect efficacy (16, 51, 355, 365). In addition, in *Neisseria* spp., the expression of outer membrane proteins that are involved in iron acquisition phase varies, including the siderophore receptor FetA in *N. gonorrhoeae* (42) and two hemoglobin receptors in *N. meningitidis* DNM2 (201) (Table 1). This may reflect a need to balance iron acquisition during growth in the host and to evade the immune system. Phase-varying colonizing factors include Ag43 in *E. coli* (64, 270) (Table 1) and Oap *H. influenzae* (281, 388).

In *Campylobacter fetus*, which is a pathogen of domestic and wild animals, a class of proteins known as surface layer proteins (SLPs) are exported to the cell surface and are noncovalently attached to the lipopolysaccharide (LPS) (80). SLPs are important virulence factors, and the absence of SLP leads to increased sensitivity to complement activity and decreased infectivity (27). These SLPs undergo extensive antigenic variation, which is achieved by so called “nested DNA inversion” (81, 83, 84, 286; reviewed in reference 82) (see “Molecular mechanisms of phase variation” below) (Table 1). Other examples of phase variation of surface proteins in gram-negative bacteria are included in Table 1.

Mycoplasma species do not have a cell wall, and lipoproteins constitute part of the surface proteins. Many of these are under the control of phase and antigenic variation (19, 20, 26, 325, 407). This includes a substrate binding component of an ABC transporter in *Mycoplasma fermentans* (351). Interestingly, the pMGA family of hemagglutinins phase varies in *Mycoplasma gallisepticum* (207, 253, 401), whereas the homologous proteins in *Mycoplasma synoviae* undergo antigenic variation (254). Expression of the Vlp family of lipoproteins in *Mycoplasma hyorhini* undergoes both phase variation and antigenic variation (47–50, 299, 300, 408). The combination of these two regulatory systems and the fact that there is a family of six related Vlp proteins that each are subject to these controls lead to a large repertoire of Vlp proteins that can be expressed (409). In *Mycoplasma* species that are human commensals and pathogens, phase or antigenic variation is indicated for *M. hominis* (190) and *M. penetrans* (250, 301).

Perhaps the best-studied example of multiphasic antigenic variation is that of lipoproteins in *Borrelia* spirochetes that are the causative agents of relapsing fever (reviewed in references 12 and 13). These lipoproteins are divided in two groups, Vlp and Vsp for large and small proteins, respectively, and can be further divided into different families, each with about 70% sequence identity (see “Biological significance of phase varia-

tion” below). One of the mechanisms involves recombination between an extensive repertoire of silent, variable *vlp* and *vsp* loci (“archival loci”) and an expression site (reviewed in reference 12). The closely related protein VlsE in *B. burgdorferi*, the causative agent of Lyme disease, is also under the control of antigenic variation through a similar combinatorial variation (181, 232, 411) (Table 1).

LPS and LOS Modification: Variation in Expression of Surface Epitopes

In gram-negative bacteria, LPS is the main constituent of the outer leaflet of the outer membrane. LPS consists of a lipid A moiety, a core of polysaccharide, and an O antigen. LPS variability among species and serotypes occurs mainly in the O antigen, specifically in the identity and number of sugars in the polysaccharide chain. In some species, the core lacks the multiple O-linked saccharide units and is often therefore referred to as lipooligosaccharide (LOS) (283). LPS, also referred to as endotoxin, is a powerful stimulant of the immune system due to the lipid A moiety, which is a pathogen-associated molecular pattern recognized specifically by toll-like receptor 4 (25).

The chemical identity of LPS or LOS is defined by the addition of side groups, for example as a result of the activity of glycosyltransferases or sialyltransferases, or by the addition of phosphorylcholine (ChoP). These traits can vary within a clonal population as a result of phase variation of one or more enzymes involved in the modification. An in-depth review of the chemical nature of modification of the O antigen of LPS is presented in reference 199. LPS modifications can impact antigenicity but can also affect serum sensitivity and adhesion. This is discussed in more detail below for the LOS of *N. meningitidis* (see “Biological significance of phase variation”). Below, additional examples are given relating to several important pathogens. Since variable LPS modification is not easily identified, it is quite possible that it occurs in other species as well.

Ganglioside mimicry of the LOS by *Campylobacter jejuni* is thought to be an important factor in the development of Guillain-Barré and Miller-Fisher syndromes after infection and is associated with specific modification of the LOS. Expression of the enzymes involved in the modification can phase vary. Alternate synthesis of gangliosides GM-2 and GM-1, like LOS in *C. jejuni* NCTC 11168, is a result of phase variation of expression of β -1,3-galactosyltransferase encoded by *wlaN* (206); in *C. jejuni* strain 81–176, reversible conversion between the GM-2 and GM-3 LOS correlates with phase-variable expression of the *cgtA* gene (111) (Table 1). Based on our understanding of these phase variation mechanisms, Linton et al. were able to show that a different *C. jejuni* strain, which had been characterized as producing only GM-2 like LOS, was able to convert to producing GM-1 like LOS (206). This illustrates how an understanding of phase variation at the molecular level may have a significant impact on the understanding of the pathogenicity and epidemiology of a pathogen.

Another well-studied example of apparent host mimicry occurs in the human gastric pathogen *Helicobacter pylori*, which can incorporate into its LPS variable carbohydrate modifications that resemble structures of the Lewis group of antigens of human blood groups. This variation occurs distinct from, and

in addition to, LPS microheterogeneity (reviewed in reference 8, 384). Three fucosyl transferase genes (*futA*, *futB*, and *futC*, also referred to as the *fucT* genes), which are each under the control of a phase variation mechanism, we involved in the LPS modification (7, 385) (Table 1). Other genes involved in LPS modification may phase vary as well (309).

In both encapsulated and nonencapsulated *H. influenzae*, modification can occur by phase-variable Lic3A or LgtC, a sialyltransferase and a glycosyltransferase, respectively (136, 137, 226, 391) (Table 1). Interestingly, these enzymes compete for the same lactose disaccharide moiety on LOS. Thus, the activity of one enzyme affects the substrate availability for the other. Phase variation of *lgt*-mediated glycosyl modification in *N. meningitidis* and *N. gonorrhoeae* is discussed in more detail below (see "Biological significance of phase variation") (Table 1).

The LOS of *H. influenzae* can also be decorated with ChoP. Phase-variable expression of the kinase encoded by *licA* results in phase-variable ChoP decoration, even though other genes may also contribute (315, 394) (Table 1). The presence of ChoP appears to confer sensitivity to serum-mediated killing caused by C-reactive protein, whereas in an animal model of the nasopharynx, this may confer a competitive advantage (214, 392, 395). Genetic analysis of three genes of the *lic* locus was performed to determine the on or off state of genes involved in LOS modification in bacteria isolated from the nasopharynx, blood, and cerebrospinal fluid in an animal model. Tissue-specific combinations were prevalent, supporting the idea that certain combinations of LOS modification may facilitate colonization or survival in different host environments (141).

Among *Neisseria* species, phase-variable ChoP modification of the LPS can occur, but type IV pili also contain ChoP (389, 394). Analysis of ChoP expression in a large group of isolates suggests that the commensal isolates decorate the LPS whereas pathogenic isolates decorate the pili (321, 322, 389) (Table 1).

Other phase-variable LOS modifications in *H. influenzae*, as well as in the related bovine pathogen *H. somnus*, exist but have not been characterized further (151, 152, 155, 402). Antigenic or phase variation of LPS also occurs in certain *Legionella pneumophila* isolates (see "Molecular mechanism of phase variation" below) (212, 213) and in *S. enterica* serotype Typhimurium (188). Modification of LOS or LPS in *Francisella tularensis* (61), *Coxiella burnetii* (98, 117), and *Chlamydia* spp. (211) varies, but the contribution of a phase variation control mechanism versus environmental regulation or mutation has not been determined.

DNA Restriction-Modification Systems

DNA restriction-modification (R/M) systems allow a bacterium to recognize and restrict foreign DNA that is not appropriately modified. Expression of some of these systems phase varies, but protein sequence variation analogous to antigenic variation also occurs (also see "Biological significance of phase variation") This was first identified in *Mycoplasma pulmonis*, a rodent pathogen. Recombination-dependent rearrangement occurs within the *hsdS* genes at two loci, each containing two copies of *hsdS* (85). The variable HsdS proteins that are synthesized from these recombinant genes each determine a different DNA sequence specificity for the DNA R/M system

(84). In addition, inversion can result in incorrect orientation of the *hsdMR* genes relative to the promoter, and therefore on/off phase variation also occurs (86, 87, 331).

Sequence analysis of other bacterial genomes suggests that phase variation of (putative) DNA R/M systems occurs in a variety of species (66, 68, 307, 309, 354) (see "Genomics and phase variation" below). Confirmation of phase variation has been obtained for expression of the *mod* gene in *H. influenzae* (66), for a type III modification system in *Pasteurella haemolytica* (304), for both the modification and restriction enzymes of a type III R/M system in *H. pylori* (70), and for a modification system in *S. pneumoniae* (275, 349) (Table 1).

In the gram-positive soil bacterium *Streptomyces coelicolor* A3(2), the phage growth limitation system determines reversible sensitivity and resistance to ϕ C31 phage. The complete molecular basis is not clear, but it is associated with phase variation of a DNA methyltransferase, PglX (192, 344). Thus, some phase-variable DNA modification systems may have evolved as a protection mechanism against phage infection.

Regulatory Proteins

DNA binding proteins that function as activators or repressors can be categorized as "global" regulators with genome-wide target sequences or as "operon-specific" or "local" regulators. The expression of multiple regulatory proteins is now known to phase vary and includes representatives of both groups. The expression state of all genes that dependent on the regulator, under both positive or negative control, will depend on the expression state of the phase-varying regulator itself. Examples are the global, virulence-associated regulatory protein in *S. pyogenes*, Mga (formerly Mry or VirR) (36, 329), and the BvgS protein of the global, two-component BvgAS regulatory system in *Bordetella pertussis* (340; reviewed in reference 228) (Table 1). The Bvg⁺, Bvg⁻, or Bvgⁱ phase variants of *B. pertussis* of later studies are not related to this phase variation mechanism. Rather, these phase variants result from the environmental modulation of BvgAS-dependent regulation (60). Expression of conjugation-related genes phase varies in *Enterococcus faecalis*, also as a result of phase-variable expression of a regulator, TraE (124, 280).

Phase-variable expression of operons is often the result of a mechanism that regulates the initiation of transcription at the main promoter of the operon (see "Molecular mechanism of phase variation" below). As a result, expression of local regulators encoded by genes in the operon also phase varies. For example, in *E. coli*, expression of the local regulator PapB, encoded by the *pap* operon, phase varies (Table 1) (33). This not only affects *pap* expression through an autoregulatory loop, but also affects type 1 fimbrial expression (97, 403) (see "Cross regulation" below) (Table 1). Together, these examples demonstrate that phase variation of a single regulatory protein can lead to coordinated, phase-variable expression of multiple cellular proteins and can establish an interdependent network of phase-variable gene expression.

Metabolism-Associated Genes

Recently, phase variation of metabolism-associated proteins was identified in the human pathogen *Streptococcus pneu-*

moniae. A comparison of protein expression patterns between two colony variants showed that at least three proteins were differentially expressed, including pyruvate oxidase (SpxB), a putative elongation factor, and a proteinase maturation protein (268). The significance of SpxB phase variation appears to be related to the hydrogen peroxide that is produced in the pyruvate oxidase-mediated conversion of pyruvate to acetyl-phosphate. The level is sufficiently high to be lethal to other species and may provide a SpxB⁺ isolate with a competitive advantage in a mixed-species environment (275, 276). This example shows that identification of differentially expressed proteins between colony phase variants can also yield insight into bacterial virulence strategies.

Phage Genes

The composition of the tail fiber of *E. coli* phage Mu determines the bacterial host range of the phage, presumably in conjunction with strain- or species-specific bacterial LPS. The composition alternates between two forms as a result of a DNA inversion event mediated by the site-specific recombinase Gin (110, 279, 363). Phage Mu is not associated with virulence of *E. coli*, but some virulence factors are phage encoded, for example cholera toxin (reviewed in reference 39). It is therefore conceivable that phase variation will be identified in phage proteins that (indirectly) affect the spread of virulence traits among natural bacterial populations and therefore will be an important feature from an epidemiological standpoint.

Concluding Remarks

Most of the genes that are known to undergo phase-variable expression encode surface-exposed proteins or proteins that modify or regulate surface proteins, and most of the putative phase-varying genes identified in genome-wide screens also belong to these classes (Table 1). However, in this section we have presented numerous examples showing that phase variation is not limited to proteins with a specific function or specific cellular location. Most phase-varying proteins were identified in bacterial pathogens of mammalian hosts, and many are proteins that affect virulence. This bias may reflect the significant focus of the research community on these organisms and does not rule out the occurrence of phase variation in commensal species or species that do not reside in or on a host. It is thus tempting to speculate that the occurrence of phase variation is more prevalent. Novel phase-varying proteins may be identified as a result of our increasing understanding of the role(s) of phase variation and through the facilitated identification of some of the underlying mechanisms using genomics. Conversely, as more phase-varying genes are identified, we will be challenged to determine their biological significance.

MOLECULAR MECHANISMS OF PHASE VARIATION

As is evident from Table 1, there is no correlation between the phase-varying phenotype and the regulatory mechanism. Specific mechanisms, however, appear to be more prevalent in certain species than others, and some, like epigenetic regulation, have been identified in only a few species. Understanding the molecular mechanisms that lead to phase and antigenic

control is a significant part of understanding how these systems contribute to the overall success of the bacterium. For example, it can help determine whether signals can be incorporated into the system that can modulate the switch frequency. This, in turn, ultimately determines the composition of the population, which impacts the evolution and dynamics of the population, the ability to adapt to new environments, and host-bacterium interactions. This section provides an overview of essential features. Recent developments in particular are highlighted. The reader is referred to other reviews that may include different examples (30, 119, 127, 140, 160, 177) and to specialized reviews when available.

Genetic Regulation

In this section the mechanisms are discussed in which the change in expression phase in an "on" cell and an "off" cell can be attributed to a DNA sequence change at a specific locus. All antigenic variation is a result of DNA sequence change and is due to one of several genetic mechanisms; this is also briefly discussed in this section. The change can be minor, with a single nucleotide change in the case of slipped-strand mispairing (SSM), or extensive, involving DNA rearrangements of fragments up to several kilobases. Phenotypic variation as a result of DNA rearrangement, irrespective of molecular mechanism involved, has been referred to as a shufflon (177).

Short sequence repeats and slipped-strand mispairing. Multiple contiguous repeats of units of DNA sequence can be subject to expansion or contraction of the number of repeats. A universal SSM mechanism is invoked in which misalignment of the repeat sequences occurs between the mother and daughter strands during DNA synthesis that occurs in either DNA replication or DNA repair. Misalignment between the daughter and parent DNA strands can occur on the leading or lagging strand at the repeat region, which results in an increase or decrease in the number of repetitive units in the newly synthesized DNA (200, 360, 362). These changes in the number of unit repeats can lead to phase-variable expression of a protein, if the location of these repeats is such that either transcription or translation of a gene is affected. Phase variation has been associated with repeat units that consist of 1 to as many as 7 nucleotides (nt). Repetitive sequence units are also referred to as short sequence repeats, microsatellites or variable number of tandem repeats (360).

Regulation at the level of transcription occurs when the repeats are located in the promoter region between the -10 and -35 sites for RNA polymerase binding (Fig. 1A, region 2). The spacing of these sites is critical for the level of transcription, and even a single-nucleotide deviation from the optimal 17-nucleotide (nt) spacing has an effect. Phase variation of the fimbriae encoded by *hif* in *H. influenzae* occurs as a result of variation between 9, 10, or 11 repeats of the dinucleotide TA located between the -10 and -35 sequences for the overlapping, divergent promoters for the *hifA* and *hifB* genes. These encode the major fimbrial subunit and chaperone, respectively. Not only does the change in strength of the promoter result in an "off" phase and an "on" phase, but also the "on" phase is represented by clones that have either a low or a high level of expression (372). A variation of this principle results in a variable level of production of the high-molecular-weight adhesins



FIG. 1. Phase variation as a result of SSM at short sequence repeats. (A) Schematic of the four positions, relative to a gene, at which short sequence repeats can cause phase variation. Indicated are a coding sequence (open rectangle), promoter (-10 , -35) with RNA polymerase (RNA pol), the $+1$ transcription start site, the Shine-Dalgarno sequence for ribosome binding (SD), and the ATG translation start codon. Repeat sequences at regions 1 through 4 can lead to phase variation by affecting transcription initiation (regions 1 and 2), translation (region 4), and as yet unidentified means (region 3) (see the text). (B) Effect on the translation product of a one-unit insertion due to SSM at the tetranucleotide repeat sequence (AGTC) in the coding sequence of *mod* of *H. influenzae* (HI056). Partial nucleotide and amino acid sequences and numbering are indicated for 31 (on) and 32 (off) tetranucleotide repeats. Note that as a result of the insertion, the reading frame changes at amino acid 177, which leads to the formation of a premature stop codon (*) following amino acid 194.

in *H. influenzae*, due to altered spacing between two promoters by SSM at 16 to 28 repeats of a 7-nt unit (65).

Transcription can also be affected by changes in repeat sequences located outside of the promoter. The change in nucleotide number can potentially affect the binding of a regulatory protein or can lead to a difference in a posttranscriptional initiation event such as mRNA stability (Fig. 1A, regions 1 and 3). Phase variation of individual fimbrial genes in *B. pertussis* is proposed to occur as a result of a change in a poly(C) tract that alters the distance between the binding sites of an activator and RNA polymerase (400). Similarly, in *N. meningitidis* strain MC58, a change in the unit repeat number in the sequence upstream of the -35 sequence of the promoter of the adhesin encoding *nadA* gene affects its promoter strength (225). Furthermore, in certain isolates of *Moraxella catarrhalis*, the length of a poly(G) tract that is located downstream of the promoter for the adhesin gene *uspA* but upstream of the translation initiation site also correlates with the level of gene expression (192).

Translation of a protein can be affected by SSM if the unit repeats are located within its coding sequence (Fig. 1A, region 4). The open reading frame is disrupted if SSM results in a change in nucleotide number that is not a multiple of three. In this case, a nonfunctional, usually truncated protein is synthesized. This is, for example, the basis of phase variation of the expression of the *mod* gene of *H. influenzae*, which contains over 30 repeats of the tetranucleotide (5'-AGTC) in its coding sequence (Fig. 1B) (66). The reading frame is altered, and, in

addition, a premature stop codon is formed as a result of one tetranucleotide addition within the coding sequence. To summarize, SSM can cause a change in the number of unit repeats consisting of 1 to 7 nt and can affect transcription initiation, a posttranscriptional initiation event, or translation.

Bayliss et al. have addressed the molecular mechanisms underlying phase variation-associated SSM. The effect of specific mutations on the switching frequency was determined for the fimbrial genes *hifAB* and *mod*, encoding a DNA modification enzyme in *H. influenzae* (18). Mutations in either of two genes that affect mismatch repair, *dam* and *mutH*, increased the frequency of change at the dinucleotide repeat tract of *hifAB* but not at the tetranucleotide repeat region of *mod* (18). A role for the mismatch repair system is also implicated in phase variation by SSM at single-nucleotide repeats in *N. meningitidis*, since increased switching rates were observed in both *mutS* and *mutL* backgrounds (291). These data indicate that a functional mismatch repair system can contribute to minimizing the occurrence of SSM at mono- and dinucleotide repeats but not at tetranucleotide repeats. In contrast, a mutation in *polI* increased the switching frequency only at the *mod* tetranucleotide repeat sequence. This suggests that incorrect processing of the Okazaki fragments results in increased instability of the region, but further details are not yet known (18). During misalignment of the strands, small loops of DNA are formed that may be stabilized by the formation of H-DNA, which was shown to form at a 5-nt repeat sequence (21). These studies show that different molecular mechanisms may be involved in

stabilizing repeat regions of different unit lengths in *H. influenzae* and, furthermore, suggest that factors or conditions that affect mismatch repair or DNA replication may also affect SSM-dependent phase variation. How much of this can be extrapolated to other species remains to be determined. Thus, the (in)stability of a given repeat sequence in a specific bacterial species cannot yet be predicted.

Even in the absence of mutations like those described above, SSM-dependent switching frequencies can vary within an isolate. The frequency of variation at *mod* in *H. influenzae*, for example, increases with increasing numbers of unit repeats at *mod* (66, 291), which is probably a general correlation. The switching frequency can also be modulated by active transcription, as was shown for SSM at a poly(dC) tract in the *siaD* gene of *N. meningitidis*. The formation of a premature stop codon in *siaD* as a result of SSM results in disruption of the coupling of transcription and translation, and this in turn facilitates Rho-dependent termination of transcription. This transcriptional termination correlated with an increase in the frequency of change in the length of the poly(dC) tract (196). It will be a challenging but important issue to determine whether regulation of the frequency of the occurrence of SSM is a common occurrence and if this is biologically significant.

Expansion or contraction of the number of nucleotides in multiples of three can cause a size polymorphism of a protein if this is located within a coding sequence. An intriguing example was described for the AhpC protein in *E. coli*. After a single triplet expansion in its coding sequence, the enzymatic function changed from a peroxiredoxin to a disulfide reductase. This change was observed under stress conditions that give a growth advantage to cells that had acquired this change but was nevertheless a reversible event (294). Whether phase variation by SSM at the level of translation significantly affects the biological function or antigenicity of other proteins is not known.

Additional examples of SSM-dependent phase variation are listed in Table 1. It is interesting that SSM-dependent phase variation of virulence factors has not been identified in *E. coli* and *Salmonella* sp., even though there does not appear to be a mechanistic constraint (294, 356). In these species, the potential to establish complex regulatory systems, which is facilitated by the large genome size, and a preference for stringent (environmental) regulation associated with their diverse natural habitats, may have influenced the acquisition or evolution of the more complex, phase variation mechanisms.

Short-sequence repeats that are not associated with phase variation, but may cause antigenic variation or other phenotypes, are discussed in an excellent review by van Belkum et al. (360). Two related topics, the identification of SSM-dependent phase-varying genes from genome sequence analyses, and the use of sequence repeats in strain identification, are discussed below in "Genomics and phase variation," and "Diagnostic and experimental significance of phase variation" respectively.

Homologous (general) recombination. Homologous or general recombination in general occurs at long (>50-bp) regions of homology and is dependent on numerous proteins that constitute part of the general DNA repair and maintenance machinery of the cell. Recombination between two alleles of a gene can lead to a gene conversion when this results in a unidirectional exchange of DNA. Gene conversion that is as-

sociated with antigenic variation in bacteria involves recombination between one of a repertoire of silent alleles of the gene and the gene located at the expression site. When alleles undergo constant changes as a result of recombination, this can be referred to as combinatorial variation. The mechanism(s) leading to gene conversion in bacteria may vary between species, but in general it requires the machinery of homologous recombination. However, several features distinguish it from most other RecA-dependent homologous recombination events. The frequency of this recombination is much higher, it occurs between regions of much lower homology than is usually considered necessary for RecA mediated recombination, and additional special *cis*-acting factors or unidentified processes appear to be involved.

Most of our understanding of the mechanism underlying gene conversion leading to antigenic variation is a result of studies of type IV pilin antigenic variation in *N. gonorrhoeae* (reviewed in reference 319). The pilin proteins that form antigenic variants of the pili are conserved for two-thirds of the N terminus but vary at the remaining C terminus. This variation is a result of unidirectional transfer to the expression locus *pilE* of a sequence from one of the silent *pilS* loci. There can be one to six copies of the silent loci on the genome, and these *pilS* loci can be separated from *pilE* by as much as 900 kb. The copies at the silent *pilS* loci consist mainly of variable regions of the gene, whereas the gene in the expressed *pilE* locus contains both conserved and variable regions. Recombination appears to require only 2 bp of conserved sequence and occurs at a high frequency ($>10^{-3}$), which are both unusual traits for RecA-dependent recombination. However, RecA is required for antigenic variation, and the RecF-like recombination pathway, in which RecA plays a role, appears to play an essential role in this unidirectional exchange (142, 182, 237, 319, 332, 413). The frequency decreases in a *recX* mutant (342). This is discussed in more detail, in the context of general recombination, repair, and replication pathways, in an excellent recent review (176). Efficient pilin gene conversion furthermore requires a conserved sequence located at the 3' end of all *pil* loci (Sma/Cla repeat) that may be a site for recombination but also appears to be a recognition sequence for an as yet unidentified DNA binding protein. Interestingly, these proteins may be present only in pathogenic *Neisseria* (376, 377).

An intriguing aspect of this recombination is that despite the unidirectional exchange of DNA, chromosomal fidelity is maintained and the sequence at the *pilS* loci is unaltered. Gene conversion can occur if the donor sequence for recombination is obtained by DNA transformation, in which case both aspects are readily resolved. However, this is not the case for the second mechanism, which appears to be predominant. In this case, DNA exchange occurs between the two copies of the genome formed by DNA replication (143, 319). The recently proposed "hybrid intermediate" model addresses how this genetic exchange occurs, and critical aspects of this model have been verified experimentally (142; reviewed in reference 176). The first step involves a RecA-independent recombination event in the donor chromosome between very short sequences of homology of a *pilS* locus and *pilE* sequence, forming an extrachromosomal circular hybrid *pilE-pilS* molecule but presumably also an additional, undefined intermediate molecule that is critical for the next step (Fig. 2A). This hybrid molecule

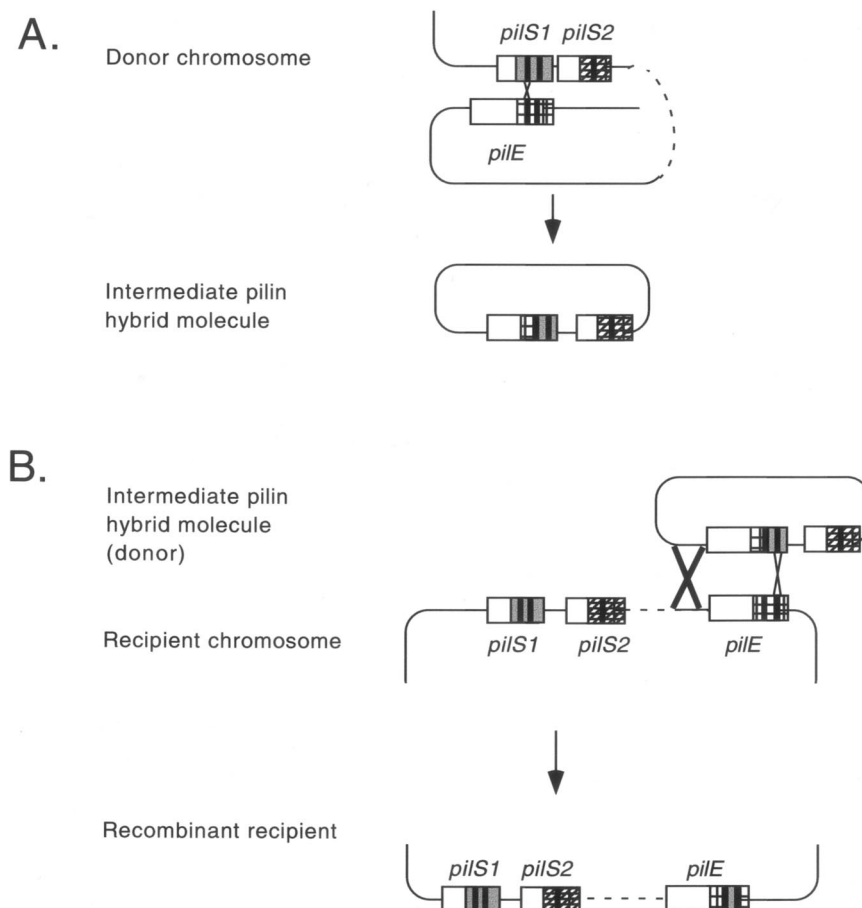

FIG. 2. Intermediate hybrid model for gene conversion at *pilE* in *N. gonorrhoeae* as a result of homologous recombination (142). Open rectangles designate the conserved region of the *pil* gene, patterns designate the different variable sequences, and the thick bar indicates some of the very short conserved sequences. (A) DNA exchange occurs between a silent *pilS* locus and the *pilE* locus of the donor chromosome at a short region of homology. This RecA-independent recombination is indicated by the light cross and results in the formation of an intermediate *pilE-pilS* hybrid molecule, depicted here as a circular extrachromosomal molecule. The predominant intermediate hybrid molecule may have a different structure (176). (B) The intermediate hybrid structure donates sequence to the *pilE* locus of the recipient chromosome, involving two crossover events, a RecA-dependent one at a larger region of homology (heavy cross) flanking the *pil* sequence and one at a short region of homology, depicted here within the *pil* sequence.

donates *pilS* sequence to the *pilE* locus in the recipient chromosome in a second recombination event. This step requires RecA and involves recombination at a larger region of homology flanking the *pil* sequences, as well as recombination at a short region of homology within the gene (Fig. 2B) (142). The recombination events result in a unidirectional exchange of variable *pilS* sequence to the *pilE* locus without altering the donor *pilS* sequence. The available experimental data do not rule out other models for gene conversion in *Neisseria*, and identifying the predominant intermediate molecular structure in the recombination step will be critical in resolving this important recombination mechanism (176).

The same mechanism that leads to antigenic variation can also cause on/off phase variation of expression of type IV pili. This occurs when a nonfunctional gene is created by the recombination reaction or if, for example, a *pilS* sequence that contains a premature stop codon is transferred to the *pilE* locus. An irreversible switch to a nonexpressing phenotype can also occur as a result of recombination-dependent deletion of complete regions of *pil* containing DNA (221, 317).

Concerning the biological role, antigenic variation of the variable major lipoprotein (Vmp) in *Borrelia hermsii* (238, 288, 289) and of the VlsE surface proteins in *B. burgdorferi* (411, 412) is well understood (reviewed in reference 12) (see "Biological significance of phase variation" below). Less is known about the mechanisms and molecular pathways underlying this antigenic variation. Detailed analysis of the genetic exchanges underlying specific seroconversion events in *B. hermsii* has, however, led to the identification of four mechanisms. The first mechanism is consistent with gene conversion and involves a nonreciprocal recombination event of genes from silent (archival) loci from a linear plasmid to an expressed locus, *vlp7*, near the telomere on plasmid lp28-1. A second mechanism involves a less frequent occurrence of intraplasmidic recombination at a region containing duplicated sequence. This results in loss of a fragment of DNA but occurs only at the expression site. A third mechanism results in introduction of point mutations at the expressed locus, but these may also originate from archival loci. Finally, by mechanisms that are not clear, transcription of the gene at the expression site on lp28-1 can be silenced in

conjunction with expression specifically of *vsp33* from a site internally located on a 53-kb plasmid. More details can be found in the excellent recent review by Barbour and in the references therein (12).

Antigenic variation is also extensive in *Mycoplasma* species (reviewed in reference 48). This includes antigenic variation of the Vsa and Vsp lipoprotein family in *M. pulmonis* (26, 325) and *M. bovis* (216) and of the VIhA hemagglutinin in *M. synoviae* (254). This antigenic variation results from genomic rearrangements and is commonly associated with DNA inversion events, which may be the result of either homologous recombination or site-specific recombination (see below). Molecular details for most molecular mechanisms remain to be elucidated for these important pathogens (138, 171, 215, 254, 325, 330). DNA inversion as a result of homologous recombination leads to antigenic variation of the SLPs in *Campylobacter fetus*. Antigenic variation of SLPs involves reassortment of eight *sap* genes, each encoding an antigenically distinct SLP, and a single *sap* promoter. The DNA inversion involves a fragment of 6.2 kb with the single promoter or, in addition, a flanking region with one or more of the variable *sap* cassettes. The DNA rearrangement positions the one *sap* promoter to transcribe one of the eight *sap* genes. These inversion events, also referred to as nested DNA rearrangements, decreased in a *recA* mutant, suggesting partial dependence on RecA (81, 84, 286).

Gene duplication by recombination is invoked in modulating the level of expression of a gene. In *H. influenzae* type b, a heritable variation in the level of capsule production occurs as a result of gene duplication of the *cap* genes, which may be enhanced by the flanking IS-like sequence. In addition, in type 1 *H. influenzae* type b, an irreversible switch to the nonexpressing type can occur when the *bexA* gene, which is essential for capsular synthesis, is lost as a result of recombination between duplicated *cap* sequences flanking *bexA* (184–186, 296; reviewed in reference 297). The latter event can be reversed only by transformation with DNA from a *bex*⁺ isolate (184, 185). Phase variation of capsule production in several *Streptococcus pneumoniae* serotypes is also associated with DNA duplication and excision. In this case, tandem duplication and precise excision of random fragments of 11 to 239 bp occur in genes essential for capsule production. Duplication of the sequence leads to disruption of the open reading frame and thus to a switch to a nonexpressing phenotype. The recombination mechanism has not been characterized but is likely to be RecA dependent since the repeat region is long (378, 379). This is reminiscent of RecA-dependent variation in the number of long repeat units (over 200 nt) in the coding sequence of the alpha C surface proteins in group B *S. pneumoniae*, the M proteins in group A *Streptococcus*, and the Esp protein in *Enterococcus faecalis*. However, in these genes the coding sequence remains in frame and the change in the number of unit repeats affects the antigenicity of the protein (107, 284).

Site-specific recombination. Nonhomologous, site-specific recombination requires specific enzymes that act at cognate DNA sequences that may have sequence identity, but often in a region of no more than 30 bp. Here the distinction is made between conservative site-specific recombination (CSSR) that can lead to inversion, insertion or excision of a DNA region, and transposition. These recombination events can lead to a variety of genetic rearrangements, some of which will lead to

phase or antigenic variation (also reviewed in references 120, 160, and 177).

Based on biochemical properties like sequence, structure, and mechanism of recombination, the CSSR recombinase enzymes associated can be divided into two major families, which are the serine and tyrosine families of recombinases, formerly designated the resolvase-invertase and λ integrase families, respectively. There is a significant amount of functional overlap among these enzymes, and enzymes of either group can mediate phase and antigenic variation. A third family consisting of two enzymes has recently also been identified, but little is known about the molecular mechanism of recombination (353). For additional details about the biochemical properties of these recombinases and the molecular mechanisms of transposition and site-specific recombination, see two recent reviews (120, 160).

(i) Inversion of a DNA element by CSSR. Recombination mediated by members of the serine and tyrosine families of recombinases occurs at short regions of DNA that contain some sequence similarity or identity required for enzyme recognition and result in reciprocal DNA strand exchange. This recombination is the molecular basis of many DNA inversion events that are involved in creating clonal antigenic diversity in bacteria and phages. Depending on whether the genetic information of this inverted element contains regulatory sequence or coding sequence, inversion can lead to on/off phase variation, biphasic antigenic variation, or even multiphasic antigenic variation.

The well-studied Cre recombinase can mediate recombination between two *lox* sequences in the absence of other factors. In contrast, in most cases where site-specific recombination leads to phenotypic variation, there is a requirement for cellular proteins in addition to the recombinase, presumably to form a recombination-proficient protein nucleocomplex. Through these factors, control of the recombination event can be exerted.

Inversion of a DNA element causes phase variation of expression of the *fim* and *fot* operons in *E. coli* and *mfp* in *P. mirabilis*, encoding type 1, CS18, and MR/P fimbriae, respectively (1, 135, 202, 416). In each case, the invertible element contains a promoter that is essential to transcribe the structural operon. This promoter is correctly positioned for this transcription in only one of the two orientations of the invertible element. The recombinase enzymes mediating the inversion, two for *fim* and one each for *fot* and *mfp*, have homology to each other and are members of the tyrosine recombinase family (135, 160). The most extensively studied system is that of *fim*, encoding type 1 fimbriae. Essential features of the *fim* system are outlined below. For a more detailed discussion, the reader is referred to an excellent review and the references therein (31).

(a) Type 1 fimbrial phase variation. Type 1 fimbriae, encoded by the *fim* operon, are the most common fimbrial adhesins in *E. coli* isolates. These fimbriae are thought to be of particular importance in mediating attachment to host tissue during bacterial colonization of the bladder, which can lead to cystitis, and can also mediate bacterial invasion into bladder epithelial cells (89, 194, 313). Expression of type 1 fimbriae phase varies as a result of the inversion of a regulatory element that contains the essential promoter for transcription of the fimbrial struc-

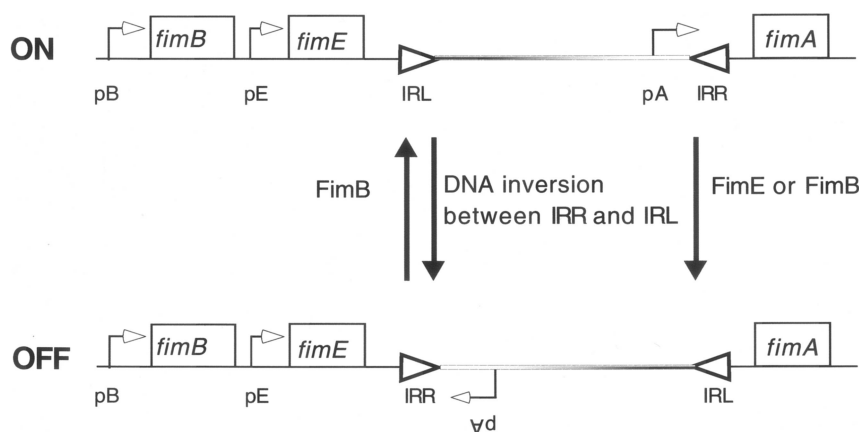

FIG. 3. Phase variation of type 1 fimbrial expression, encoded by the *fim* operon, in *E. coli* as a result of DNA inversion mediated by SSM. The relative positions of the promoters (open arrows), genes (open rectangles), and inverted repeats IRR and IRL (triangles) at *fim* are shown. The invertible DNA sequence and its orientation are depicted by a shaded bar. IRR and IRL are within the binding sites for the recombinases FimB and FimE. Binding sites for other regulatory proteins (Lrp and integration host factor) are not shown (see the text). The drawing is not to scale and is not meant to convey protein size or other biochemical properties.

tural genes, the *fimA* promoter (Fig. 3). The invertible element consists of 296 bp flanked by two 9-bp inverted repeats (IRR and IRL). The main subunit of the fimbriae is FimA, and the *fimA* promoter is properly orientated for transcription of *fimA* when the inverted element is in the “on” orientation. In the “off” orientation, the promoter is incorrectly oriented for transcribing *fimA* and fimbriae are not synthesized. Thus, the inversion event is the main feature of this phase variation system. This DNA inversion is mediated by the two site-specific recombinases, FimB and FimE. These have 48% amino acid identity, but their DNA specificity and activity differ. FimB mediates inversion in both directions, whereas FimE mediates the inversion predominantly in the “on” to the “off” direction (174, 230). The FimE bias is due in part to its substrate preference for DNA in the “on” orientation (102, 187). The frequency of inversion mediated by FimB is on the order of 10^{-3} to 10^{-4} , whereas the FimE-mediated inversion frequency is as high as 10^{-1} .

The relative amount of the two recombinases affects the net phase variation rate of type 1 fimbriae. The *fimB* and *fimE* genes are each transcribed from their own promoters (Fig. 3), and several factors have been identified that regulate the transcription of these genes. For example, H-NS affects both *fimB* and *fimE* transcription (260, 261) whereas DNA supercoiling affects *fimB* transcription (79, 130). Recently, it was determined that *N*-acetylneuraminic acid suppresses FimB expression as well as recombination. This regulation requires the presence of a newly identified, *cis*-acting regulatory element that is located over 600 bp upstream from the *fimB* promoter. This element contains regions that function as a silencer and regions involved in antirepression (91). Thus, by regulating the transcription of the recombinase genes, phase variation rates are affected. The significance of incorporating regulatory signals may be, in part, to signal the presence in the intestine of the host.

The level of FimE expression also is affected by posttranscriptional regulation. Specifically, the level of expression is higher when the orientation of the downstream invertible element is in the “on” orientation than when it is inverted. This

“orientation control” is a result of differential stability of the *fimE* transcript. The transcript is quite stable when the invertible element is in the “on” orientation, and the transcript extends into the switch region. The *fimE* transcript is less stable when the element is in the “off” orientation. Differential stability may be the result of the formation of a Rho-dependent terminator in the “off” orientation or that of a secondary structure that stabilizes the transcript in the “on” orientation (166, 335). Thus, the invertible element exerts its control at two levels, first by affecting the orientation of the main *fimA* promoter and second by affecting the level of FimE production.

The relative amounts of FimB and FimE are important in current models of regulation, but a much more complex picture of *fim* regulation has emerged. For example, a bias to the “off” phase occurs as a direct result of transcription originating at the *fimE* promoter, even in the absence of functional FimE (260). Several lines of evidence also suggest that transcription from the *fimA* promoter and the DNA inversion event are mutually exclusive (260). In addition, an “off” phenotype in which fimbriae are not produced can be obtained even with the DNA in the “on” orientation, as a result of posttranscriptional regulation (229). Furthermore, various cellular factors influence the recombination reaction, including the host factors Lrp, integration host factor, and H-NS, presumably by assisting in the formation and stabilization of the recombination-proficient protein nucleocomplex (32, 78, 90, 101, 103, 260, 262). The interaction of these regulators with the *fim* DNA can be modulated, as illustrated by the effect of the branched-chain amino acids and alanine on the Lrp binding affinity (298). Thus, environmental factors can affect *fim* phase variation, not only by affecting the level of recombinase(s) but also by directly influencing the inversion reaction.

Differences in *fim* phase variation rates have been found among clinical isolates. One of the identified differences may lie in variable FimB expression due to its dependence on the availability of the minor tRNA LeuX (293). The *leuX* locus is often linked to pathogenicity islands, and its expression may vary in concert with that of virulence factors (74, 75). In addition, sequence variation of the invertible element and the pu-

tative presence of an additional, strain-specific transcriptional activator have been implicated in strain-dependent variation. These differences in *fim* regulation may influence the relative success of a strain in different environments.

Our understanding of the molecular mechanism underlying the *fim* expression system has made it possible to address the occurrence and role of *fim* phase variation in vivo. The percentage of bacteria that contained the element in the "on" position was determined in animal models of urinary tract infection (114, 145, 343) and in bacteria isolated from women with urinary tract infections (205). In addition, using the mouse model, the effect on bacterial colonization of preventing inversion of the *fim* invertible DNA element was examined (113). Both lines of research suggest that phase variation itself is an important feature during different stages of infection. With a phase-varying isolate, a bias to the "on" state was observed in bacteria in the bladder at specific times of infection, but the relative contributions of regulation of phase variation and of host-driven selection against a specific expression phase are not yet clear. Applying this general approach to other infection models should yield valuable insights into bacterium-host interactions and the role of phase variation in this interaction.

(b) *Other CSSR-dependent types of phase variation.* DNA inversion-mediated site-specific recombination causes an interesting combination of antigenic and phase variation of the PilV protein of the type IVB pilus in *S. enterica* serotype Typhi (415). Inversion is mediated by the Rci recombinase, which is a member of the tyrosine recombinase family. Rci was first determined to be involved in inversion associated with a shufflon located on plasmids pR64 and pR721. This shufflon determines which of seven C-terminal ends is incorporated into the PilV subunit of the pilus, and this determines the host range for plasmid transfer. The Rci-mediated inversion at the *pilV* gene of *S. enterica* serotype Typhi, however, results in biphasic antigenic variation of the type IVB pilus. Inversion of a 490-bp fragment causes one of two variable C termini to be fused to a constant N terminus of PilV, which is a minor component of the pilus. However, under conditions favoring very rapid inversion, specifically when DNA is highly supercoiled, neither PilV protein is expressed. It is thought that RNA polymerase becomes detached during the inversion process and that therefore during very rapid inversion there is insufficient time for RNA polymerase to synthesize a full-length transcript (243, 414). The antigenic variation affects receptor recognition of the pilus, whereas pilus-mediated autoaggregation occurs in the absence of PilV expression.

DNA inversion is also mediated by members of the serine recombinase family (also called the DNA invertase family), for example, Hin-mediated recombination leading to flagellar H1/H2 antigenic variation in *S. enterica* serotype Typhimurium. The main difference with tyrosine recombinase-mediated DNA inversion lies in the details of the biochemistry and mechanism of recombination (reviewed in references 120 and 160). H1-H2 antigenic variation is a result of expression of either FliC or FljB, respectively, and is a result of Hin-mediated site-specific recombination at two 26-bp inverted repeats. This causes inversion of a 995-bp region that contains the promoter for *fliB* and *fljA* (formerly designated rH1) (316, 327, 328). Thus, when the promoter is oriented toward transcription of the *fljBA* operon, FljB (H2) flagella are expressed concom-

itant with the repressor *fljA*. FljA represses *fliC* expression by affecting both transcription and translation and may interact with the 5' untranslated region of *fliC* (35). On Hin-mediated inversion, *fliB* and *fljA* are not transcribed, *fliC* repression is abrogated, and H1 flagella are expressed. Similar to Fim-mediated inversion, cellular factors facilitate the formation of the protein nucleocomplex that must be formed to allow the recombination to occur and is required to activate the recombinase (125). These factors will influence the rate of inversion, as illustrated by a 150-fold increase in the rate of Hin-mediated inversion by Fis binding to the recombination enhancer element and Fis-Hin interactions (161, 239, 364). Other recombinases in this family include the phage-encoded Gin and Cin of *E. coli* Mu and P1, respectively. These enzymes cause a DNA inversion event that determines the composition of the phage tail fiber and thus the host range of the bacteriophage (110, 149, 363).

The recombinase Piv in *Moraxella bovis* and *M. lancunata* also mediates a DNA inversion event, which causes antigenic and phase variation of type IV pili (197, 222, 223). Piv is not a member of the tyrosine or serine recombinase family but has sequence similarity to MooV transposase, which is involved in phase variation in *Pseudoalteromonas atlantica* (see below) (353). Piv causes DNA inversion between the coding region of *tfpQ* and *tfpI*, which determines which of these pilins are expressed and incorporated in type IV pili. In *M. lancunata*, TfpI contains a mutation that inactivates the gene product, and therefore inversion in this species leads to on/off phase variation of TfpQ (302).

Eight loci have been identified in *B. fragilis* that encode eight different capsular polysaccharides. Expression of each is under the control of on/off phase variation. At seven loci, the expression phase correlates to the orientation of an invertible DNA element in the locus. This element contains the promoter of a regulatory gene for the corresponding locus. One specific invertible element consists of 193 bp that is flanked on each side by a 19-bp inverted repeat sequence. The other invertible elements are of similar size and are flanked by similar inverted repeats. The corresponding recombinase(s) has, however, not been identified yet (183a).

(ii) **Insertion and excision of genetic elements from the chromosome.** Transposition can mediate reversible phase variation only if excision is precise, with restoration of the original sequence of the recipient DNA; in most transposition events, the original sequence of the recipient DNA is not restored after excision of the transposing element. Furthermore, classic transposition in general does not target a specific DNA sequence. In contrast, transposition mediated by the putative transposase MooV does lead to phase variation; indeed, this transposition requires short sequence identity between the insertion element and the target sequence (277). Therefore, transposition-mediated phase variation can occur but may be limited to a specific group of transposable elements and recombinases.

MooV appears to mediate phase variation of the extracellular polysaccharide encoded by the *eps* locus in certain isolates of the marine bacterium *P. atlantica*. Phase variation of *eps* expression affects biofilm formation, which is thought to be an essential part of its alternating life-style of growth on solid surfaces and in the open ocean. This reversible switch from an

“on” to an “off” expression phase occurs by precise excision of an IS492 element from the *eps* locus, which appears to be mediated by MooV. A specific 5-bp sequence that is essential for insertion and excision is found at the target sequence for insertion and at the junction of the ends of the IS492 element in circular form. On excision, the element is found as a circular, extrachromosomal element. Whether this is an intermediate or end product of the recombination event is not clear. The formation of this circular DNA may play a regulatory role, since it results in the formation of a strong promoter for MooV (17, 277).

Phase variation of *ica* expression in *Staphylococcus epidermidis* correlates with the insertion and precise excision of an IS256I element in the *icaA* or *icaC* gene (419, 420). Expression of the *ica* operon results in formation of a polysaccharide adhesin that facilitates cell-cell interactions and biofilm formation. Excision of the IS256I element results in the formation of an extrachromosomal circular element, as described for IS492-mediated phase variation of expression of *eps* (208, 420). Phase variation of capsule production in *Citrobacter freundii* and in *Neisseria meningitidis* is also regulated by insertion and excision of IS-like elements (121, 267). Many other species contain abundant IS elements that sometimes vary in number and position among isolates, and it will be of interest to determine if this sometimes also functions as a phase variation mechanism.

In the examples above, phase variation is a result of insertion and excision of DNA elements that are readily recognizable as insertion sequence elements. In contrast, in some isolates of *Legionella pneumophila*, phase variation is associated with reversible excision and insertion of a 30-kb plasmid into the chromosome. The molecular mechanism is not clear, but it appears to be a RecA-independent event (212). Variable expression of the LPS occurs, including a modification by N methylation of legionaminic acid and various cell surface structures (179, 213). The site of insertion of the plasmid in the chromosome appears to be irrelevant for the phase variation phenotype. Instead, the change in copy number of the plasmid associated with the chromosomal or episomal presence is thought to affect the level of expression of a plasmid-located gene that may be involved in the regulation of phase-variable genes (212, 213).

Epigenetic Regulation

In contrast to the mechanisms described above, epigenetic regulation of phase variation occurs in the absence of a change in DNA sequence. Instead, it involves differentially methylated sequences in the regulatory regions of the phase-varying gene or operon. Since the expressed state is heritable but reversible and since regulation is not caused by a DNA sequence change, it is by definition epigenetic. The essential feature of the DNA methylation-dependent phase variation systems is that the methylation state of a target sequence at a specific site in the chromosome affects the DNA binding of a regulatory protein that directly regulates transcription. Expression of the DNA methylase itself does not undergo phase variation. Methylation-dependent phase variation has been identified in *E. coli* and *S. enterica* serotype Typhimurium. An epigenetic mechanism was first elucidated for phase variation of expression of

the *pap* operon encoding pyelonephritis-associated pili in *E. coli* and is now known to regulate phase variation of a family of *pap*-like fimbrial operons in these species and of the outer membrane protein Ag43. The essential features of these two epigenetic phase variation systems are outlined below.

Pap phase variation. Most uropathogenic *E. coli* isolates can express pyelonephritis-associated pili (Pap or P pili) (144). Expression of the *pap* operon phase varies, and this is dependent on deoxyadenosine methyltransferase (Dam), the two Dam target sequences (GATC) in its regulatory region, and the global regulator leucine-responsive regulatory protein (Lrp) (Fig. 4) (40). Phase variation further requires the *pap*-specific regulatory proteins PapI and PapB and the global regulator catabolite activator protein (CAP). The *pap* regulatory region consists of 416 bp containing binding sites for these regulatory proteins and two divergent promoters. The pI promoter is for transcription of the gene encoding the PapI regulatory protein, and pBA is the main promoter for the *pap* operon. The GATC site distal to the main pB promoter is designated GATC^{dist} (also referred to as GATC¹⁰²⁸ or GATC-I), and the one proximal to the pBA promoter is designated GATC^{prox} (GATC¹¹³⁰ or GATC-II), respectively. The two GATC target sequences are 102 bp apart, and each is within a distinct Lrp binding region (Fig. 4).

Phase-variable expression of *pap* is a result of the dual action of Lrp at the *pap* pB promoter, as both a repressor and an activator. Which of these roles it fulfills depends on which of the two binding regions in the *pap* operon it is occupying (128, 370). If Lrp is bound at the GATC^{dist}-containing region, it acts as an activator and the cell is in the “on” phase for expression of *pap*. If Lrp is bound at the GATC^{prox}-containing region, it is a repressor of pB transcription, and the cell is in the “off” phase (Fig. 4) (397). Thus, the key to understanding this switch is to determine how Lrp binding alternates between these two sites.

Differential binding of Lrp is facilitated by DNA methylation and by the PapI protein. PapI is a small (8-kDa) protein that was shown to be in direct contact with Lrp but also appears to bind at the *pap* GATC^{dist} region with a very low affinity (128, 168). However, a high-affinity interaction occurs between DNA, PapI, and Lrp that requires a specific DNA sequence (ACGATC) found at the *pap* GATC sequences (128, 129). It was initially determined that the affinity of Lrp for GATC^{dist} increased in the presence of PapI, which facilitates a switch to the “on” phase. Conversely, methylation at GATC^{dist} decreased the Lrp binding affinity, which is an essential feature for maintaining the “off” phase (257, 258). More detailed in vitro analyses of protein-DNA interactions have shown that PapI also enhances the binding of Lrp at the GATC^{prox}-containing Lrp binding region. The degree to which Lrp affinity is affected by PapI varies between the proximal and distal binding sites and depends on the methylation state of the GATC sites. Recent work indicates that methylation of GATC^{prox} prevents PapI-dependent Lrp binding at the pBA-proximal region but does not prevent Lrp-dependent binding. This appears to be a key feature for maintaining the “on” phase (128, 129). Thus, the methylation state of the GATC sequences in conjunction with PapI determine the Lrp binding site and thereby control the *pap* expression state.

The *pap* expression phase is heritable as a result of the

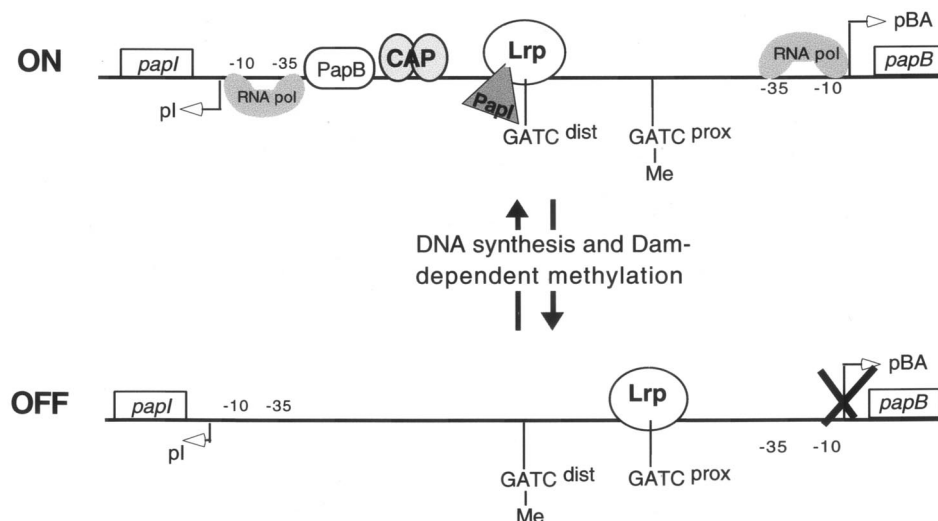

FIG. 4. DNA methylation-dependent phase variation of the *pap* operon in *E. coli*. Proteins that are essential for the “on” and “off” phases, and the relative positions of their binding sites, are depicted. Note that the methylation state of the two GATC DNA sequences, depicted by Me, also differ in the two phases as a result of the accessibility of Dam. The drawing is not to scale and is not meant to convey protein size or biochemical properties. See the text for additional information.

inheritance of the DNA methylation state of the two GATC sequences. A nonmethylated state will be maintained and inherited as long as Lrp remains bound, because Lrp blocks the ability of Dam to access the GATC sequence contained within the occupied Lrp binding site. This occurs at both GATC-containing regions. The site that is methylated will continue to be so since it is accessible to Dam (128, 397). This raises the question of how a switch in expression phase can occur. Even though it has not yet been directly proven, it is thought that the switch in the occupied Lrp binding site can take place, when the DNA is transiently hemimethylated following DNA replication. Consistent with this, the affinity of Lrp-PapI for hemimethylated *pap* DNA was found to be higher than for the same DNA when methylated on both strands. This links a change in *pap* expression phase to cell division.

The level of expression of the regulatory proteins PapI and PapB depends on the level of transcription originating at the pI and pB promoters. PapI is necessary for phase variation, as described above. PapB activates pI, whereas at higher concentrations it represses its own promoter, pB, resulting in auto-regulation (97). Other factors that modulate the activity of these promoters also affect phase variation. For example, cyclic AMP (cAMP)-CAP directly activates transcription at pB and probably also at pI (128, 396). Some of the DNA binding proteins may play a second role by facilitating the formation of a stable DNA-protein complex at *pap*.

This description of the essential features of the *pap* phase variation mechanism is, however, a simplification of the system, and various aspects still remain to be elucidated. For example, one novel and potentially critical feature identified from recent work is the principle of “mutual exclusion,” in which the binding of Lrp at one region in *pap* decreases its affinity for the second in *cis* site, even though the binding sites do not overlap. How this occurs at the molecular level is as yet unknown. A more in-depth discussion of this and other fea-

tures of the *pap* regulatory system can be found in reference 128.

Based on the presence of homologous regulatory proteins and conserved regulatory sequences, a family of fimbrial operons has been identified in *E. coli* and *S. enterica* serotypes. These are regulated according to the same Dam- and Lrp-dependent principle, even though variations do exist (251, 369, 371). For example, leucine does not affect the binding of Lrp at *pap* but does affect it at the *clp* fimbrial operon affecting the phase variation of CS31A fimbriae (62). Furthermore, the PapI homolog of the fimbrial operon *pef* in *S. enterica* serotype Typhimurium stimulates transcriptional repression and not activation of *pef*, presumably due to a different organization of Dam target sequences and protein binding sites (251). Several other *trans*-acting factors, including cAMP-CAP, temperature, and pH, also differentially affect the regulation of the various members of the *pap* family (31, 183, 251, 399).

Ag43 phase variation. Dam is also required for phase variation of expression of the *agn43* gene (also designated *flu*) in *E. coli* (72, 116, 126). This gene encodes the outer membrane protein Ag43, which causes autoaggregation, enhances biofilm formation, and may affect phage adsorption (64, 100, 269). The regulation of phase variation of Ag43 is quite different from that of *pap* and requires only the oxidative stress response protein OxyR in addition to Dam. The *agn* regulatory region contains three GATC sequences that are located within a binding site for OxyR. OxyR is a repressor of *agn43* but binds this region only when the GATC sites are nonmethylated. Methylation of the GATC sequences is required to abrogate the binding of OxyR and results in the “on” phase. Once OxyR is bound, access of Dam is blocked, which allows the “off” state to be maintained (116, 126, 380, 383). Thus, phase variation is a direct result of competition between OxyR and Dam for the *agn43* region and is therefore sensitive to intercellular concentrations of OxyR and the Dam/DNA ratio, which determines

the level of DNA methylation (59). The oxidation state of OxyR does not affect its role as a repressor for *agn43*, which is unusual for a member of the OxyR regulon (382). Despite sequence divergence in the coding and regulatory regions, the nucleotides that are essential for Dam- and OxyR-dependent phase variation are conserved among the sequenced *agn43*-like genes (3, 295, 383). Thus, it is predicted that these *agn43* genes also undergo Dam- and OxyR-dependent phase variation; indeed, the expression of the *agn43*-like gene of the neonatal meningitis isolate K1 phase varies (383).

No other Dam-dependent phase-varying systems have been identified. However, Dam is a conserved protein in various species, including pathogenic *Yersinia pestis*, *Y. pseudotuberculosis*, and *Vibrio cholerae* (210), and therefore phase variation according to the same principle of methylation-dependent binding of a regulatory protein seems possible. Methylation-dependent phase variation could potentially also be mediated by DNA methylases that are part of R/M systems.

Phase Variation as Part of the Cell's Regulatory Network

Cross regulation. In early studies of fimbrial gene expression in *E. coli*, it was noted that, in general, a strain would express only one fimbrial type at a time. For example, *E. coli* strain KS71 has the potential to express P, type 1C, or type 1 fimbriae, but in general it expresses only one of these on an individual cell. In this strain, fewer than 10% of the individual cells express two types of fimbriae simultaneously (259). Recently, the molecular basis for coordination between phase variation of expression of type 1 and Pap fimbriae was elucidated. The PapB regulatory protein is transcribed from the phase-variable *pap* promoter pB (see above). Xia et al. showed that PapB expression results in a decrease in the percentage of type 1-expressing cells. PapB binding at *fim* directly inhibits the FimB-mediated DNA inversion at the *fim* operon encoding type 1 fimbriae. In addition, PapB caused an increase in expression of the second recombinase, FimE, which results in an increase in the switching frequency of type 1 from "on" to "off" (403). The PapB homolog of the *sfa* operon, SfaB, also represses type 1 expression, but the homologs of other *pap*-like fimbrial operons, including DaaA, FaeB, FanA, FanB, and ClpB, do not (134). Furthermore, PapB, PapI, and their homologs can influence phase variation of expression of the other *pap*-like operons, even though this cross regulation may also be limited to a subset of operons in this family (371). Thus, phase-variable expression of one operon can directly influence the switching frequency of a different phase-varying operon.

Coordination of expression has also been identified between fimbrial operons that phase vary and flagellar operons that do not phase vary. In *P. mirabilis*, coordinated expression occurs between phase-varying MR/P fimbriae and non-phase-varying flagella. When the *mrp* operon is in the "on" phase and expressed, transcription of the flagellar operon is repressed. This is mediated by the *mrpJ* gene in the *mrp* operon, which encodes a regulatory protein that indirectly exerts a negative control over transcription of the flagellar operon (203). In *E. coli*, the MrpJ homolog, PapX, of the phase-varying fimbrial *pap* operon appears to play a similar role (202, 416), and in *S. enterica* serotype Typhimurium, the FimZ protein of the phase-varying fimbrial *fim* operon affects flagellar expression (54, 405). Ex-

pression of these regulatory proteins can be under the phase variation control mechanism of the main promoter of the operon. Thus, as a result of phase-variable expression of the fimbrial operon, flagellar expression also appears to phase vary. This coordinated expression could have evolved to facilitate fimbria-mediated bacterial adhesion by decreasing motility.

In *E. coli*, expression of the phase-varying outer membrane protein Ag43 and that of several phase-varying fimbriae also appears to be coordinated. Fimbrial expression results in a decreased presence of Ag43 on the cell surface. The underlying regulatory mechanism is not clear, since not all experimental data are consistent with a proposed model of coordinated transcriptional regulation in which the oxidation state of OxyR mediates the coordinated expression (310, 311, 382). An intriguing alternative is the global regulatory two-component CpxAR system, which senses misfolded proteins in the periplasm and can be activated by bacterial surface attachment (266). CpxAR activation modulates the level of expression of Pap fimbriae in a culture, apparently by increasing the switch frequency from off to on (128, 148). It seems likely that cross regulation by this or other mechanisms that result in coordinated expression of cell surface structures, including those that phase vary, is a more common occurrence than is currently recognized.

Environmental regulation. Environmental regulation of gene expression allows the bacterium to be optimally suited to its growth environment. Thus, one may expect that the expression of phase-variable genes would also be under environmental control, and this does indeed occur. Iron starvation, for example, increases the frequency of antigenic and phase variation of *N. gonorrhoeae* pili and may be correlated with a general change in the DNA recombination rate and the DNA repair rate. Low iron concentrations are often encountered by this obligate human pathogen during infection and thus are likely to be an important signal for the success of this bacterium in the host (323). Stimuli that affect the expression of phase-variable fimbriae in *E. coli* and *S. enterica* serotype Typhimurium include temperature, pH, carbon source, and amino acid concentration; they may serve to signal whether the bacterium is in a host and, if so, in which organ or tissue (reviewed in references 29, 31, and 183). The signals may result in regulation that is epistatic to the phase variation control mechanism, as is the case for cAMP-CAP-mediated activation of the *pap* operon (396). A comprehensive review of the environmental conditions that affect individual phase variation mechanisms is beyond the scope of this article.

The way in which environmental stimuli are incorporated into the regulatory system will depend in part on the phase variation mechanism involved. Environmental signals may affect the switch frequency of phase variation or may be epistatic to the phase variation mechanism. This distinction can be important, since the latter may allow a rapid adaptive response in cells in the population. For example, if cells are in a genetic or epigenetic "on" state, promoter activity can be rapidly repressed by regulatory proteins acting in *trans*. In contrast, a change in the switch frequency will affect the composition of the bacterial population as a whole and in most cases will require DNA synthesis, resulting in a slower response. The effects may not always be independent, as appears to be the case for temperature-dependent repression of *pap* mediated by

H-NS. A rapid repression of promoter activity occurs at a temperature downshift from 37 to 23°C, but over several generations the DNA methylation state that determines the expression phase is affected as well (398). The switching frequency mediated by SSM can also be affected by the activity of the promoter (22, 196). SSM-dependent phase variation of SclB in *Streptococcus pyogenes* was monitored by analysis of the variable number of repeats after growth in fresh human blood and in medium. Only in the former were variations found, which also indicates that environmental conditions or selection pressures can affect SSM-dependent phase-variable expression of this protein (285).

Concluding Remarks

Regardless of the mechanism, per cell the switching event of phase variation is a stochastic event and thus is random. However, our increased understanding of the molecular mechanisms underlying phase variation is emphasizing that phase variation and the regulatory systems that determine the general physiological state of the bacterium are not separate processes and that the switch frequency can be modified by specific growth conditions or physiological states. Furthermore, most systems appear to require DNA synthesis, either for DNA repair or for DNA replication, and this also establishes a link between a change in expression phase and the physiological state of the bacterium. Thus, perceiving phase variation as a random, nonregulated process may lead to incorrect conclusions when addressing the significance of phase variation. Furthermore, some phase variation systems can affect the expression of other, unrelated cellular proteins. Finally, it is clear that the expression of certain genes that undergo phase variation can enhance survival. How the different mechanisms, environmental regulation, and the gene products each contribute to the success of the bacterial population largely remains to be determined. However, this, together with ongoing efforts to identify environmental signals and regulatory networks that influence phase variation, will probably contribute to our understanding of the global changes that allow bacteria to adapt and survive in a changing environment.

GENOMICS AND PHASE VARIATION

In April 2003, 91 complete and annotated bacterial genomic sequences were available to the public through the Comprehensive Microbial Resource database at The Institute for Genomic Research (<http://www.tigr.org/tigr-scripts/CMR2/CMRHomePage.spl>), and the number is rapidly increasing. The extent to which analysis of these genomes can yield novel information about phase variation depends in part on how much is known about the mechanism of regulation. The presence of homologs of PapI and PapB and of a conserved region surrounding the Dam target sequences of *pap* (GATC boxes) facilitated the identification of the *pap*-like family of phase-varying fimbrial operons (128, 251, 369, 371). This approach succeeded since multiple characteristics could be probed and the proteins have a high degree of homology. Phase variation that is mediated by DNA inversion may be identified by the presence of a gene encoding for a site specific recombinase

(see "Molecular mechanisms of phase variation" above). However, since site-specific recombinases are also involved in non-phase variation processes, the proximity to a putative virulence gene may be required to stimulate interest. Indeed, identification of recombination-dependent antigenic variation of PilV was facilitated by the presence of the recombinase gene *rci* adjacent to *pilV* in the *S. enterica* serotype Typhi chromosome (243, 414). Thus, genome analysis can identify novel phase or antigenically varying systems and assist in the identification of the regulatory mechanism as well.

The greatest success in identifying novel phase-varying systems from genome sequences has been for putative SSM-dependent systems. Genomes were analyzed for the presence of short sequence repeats, and, when possible, comparison of multiple related genome sequences was used to identify repeat tracts that are susceptible to variation between strains. Using this general approach, putative phase-varying genes have been identified by different groups in *H. influenzae* (95, 137, 361), *H. pylori* (4, 34, 104, 309, 354) *C. jejuni* (274, 386), *S. pneumoniae* (349), and *Neisseria* spp. (273, 307, 334, 350). For example, 19 putative SSM-dependent genes were identified in *H. influenzae* (95, 137, 361) and 82 were identified in *N. meningitidis* strain MC58 (273, 307). Of the latter 82, the identification of 19 was facilitated by comparative analyses of three neisserial genomes (334). The computer-based approach has the advantage that it is rapid and that phase variation is identified without a bias to a certain functional class of proteins, allowing phase variation to be discovered for novel classes. For example, phase variation of DNA restriction modification systems in *Haemophilus influenzae* and *Helicobacter pylori* was postulated based on genome analysis, and experimental analysis showed that this indeed occurs (66, 70).

Despite the successes of this genome-based approach, the presence of a short sequence repeat is not sufficient to conclude that phase variation of expression of the gene occurs. For example, a short poly(dA) tract in the *futC* gene in *H. pylori* facilitates ribosomal frameshifting during translation and not SSM (385). Recently, variation in the length of repeat sequence in numerous *Neisseria* strains and isolates was analyzed for 20 repeat sequences found in *N. meningitidis* strain MC58. This analysis led to the prediction that the expression of 18 of these genes with repeat sequences is unlikely to phase vary (225). A correlation was found between the characteristics of the repeat unit and the interspecies variation in the number of repeat units. For example, four repeats of a dinucleotide unit appeared to be stable. Similarly, it is likely that the 397 SSRs of 1 to 3 nt identified in *S. pneumoniae* TIGR4 is larger than the number of phase-variable genes (349). First, various repeats were located in important central metabolism genes and therefore are less likely to be phase variable. In addition, the rate at which slippage occurs depends on the DNA sequence and the number of repeats, and the stability of a given sequence is likely to be species dependent (66, 340) (see "Diagnostic and experimental significance of phase variation" below). However, our ability to accurately predict the genes whose expression phase varies based on genome sequence analysis should increase as more phase variation systems and the underlying processes are characterized in different species.

BIOLOGICAL SIGNIFICANCE OF PHASE VARIATION

Borrelia species are thought to evade adaptive immune responses encountered in blood or the lymphatics by a combination of a “stealth design” (i.e., a periplasmic location of flagella and the absence of LPS) and antigenic variation of surface structures (i.e., outer membrane lipoproteins). Convincing support for this view comes from animal experiments. In relapsing fever (caused by *B. hermsii*), each relapse is caused by an antigenic variant expressing a new variant of its variable major lipoprotein (Vmp), as indicated by the isolation of a new serotype. Peak antibody titers against Vmp variants appear subsequently in the order in which variants are isolated, thereby suggesting that new serotypes arise from Vmp variants that escape a specific antibody response (55, 56, 238, 341). In *B. burgdorferi*, the etiologic agent of Lyme disease, surface variation involves antigenic variation of VlsE, a surface-exposed lipoprotein encoded by linear plasmid lp28-1 (411). While the *B. burgdorferi* wild type causes a chronic infection in mice, a mutant lacking linear plasmid lp28-1 begins to be cleared by day 8 after infection when adaptive immunity develops (189). The mutant lacking linear plasmid lp28-1, however, does persist in mice unable to mount an adaptive response (C3H-*scid* mice), thereby supporting the view that antigenic variation of VlsE allows *B. burgdorferi* to evade adaptive immunity (189). The above correlation between the onset of an adaptive immune response and the *in vivo* selection for *Borrelia* variants has given rise to the concept that antigenic variation of surface structures is a powerful mechanism for evasion of adaptive immune responses by bacteria, thereby allowing them to cause chronic or recurrent infections. However, a correlation does not imply causality, illustrating that some aspects of this hypothesis remain to be tested. Furthermore, while studies of *Borrelia* pathogenesis are limited to the role of antigenic variation in immune evasion, a common extrapolation is the assumption that other mechanisms involved in surface variation, such as phase variation, may also be involved in immune evasion. A review of the literature indicates that this assumption has rarely been tested experimentally.

Persistence through Surface Variation

Variation of all major surface antigens is a hallmark of pathogens persistently colonizing mucosal surfaces, such as *N. gonorrhoeae* (gonococcus), *N. meningitidis* (meningococcus), and *H. influenzae*. Here, expression of surface structures is altered by a combination of antigenic variation and phase variation mechanisms. The resulting surface variation has been proposed to allow immune evasion during chronic or recurrent infection and/or the generation of variants with altered ability to colonize niches in the host (67, 245, 346). As discussed below, these conclusions are based mainly on *in vitro* models while studies using the natural host provide little support for preferential colonization of niches by antigenic variants and are often not designed to monitor the evasion of adaptive immune responses over time.

One prototypical example of an organism persistently colonizing mucosal surfaces is the gonococcus, a strictly human-adapted pathogen. Gonococci can persist in the human population because they are able to cause chronic infections of the

mucosa in the genitourinary tract, thereby ensuring continued transmission within the population even if the opportunity to encounter a new susceptible host may be relatively rare (as is the case for sexual transmission). Since gonococci do not survive in the environment, a large part of their genome is devoted to encoding factors necessary for survival in their niche, the genitourinary tract (249). Colonization of the mucosa of the genitourinary tract leads to a local inflammatory response that is rarely followed by bacteremia. One mechanism used by gonococci to persist in the genitourinary tract is thought to be the evasion of adaptive immune responses directed against antigens displayed on their surface. The variation of surface structures is mediated by a combination of antigenic variation and phase variation mechanisms to alter the composition or expression of prominent surface antigens, including type IV fimbriae (10, 118, 318), LOS (11, 63), colony opacity proteins (Opa) (23, 246) and other outer membrane proteins (42, 43, 58).

One challenge of constantly altering the antigenicity of the bacterial surface for the purpose of immune evasion is to maintain functionality of surface structures required for the host-pathogen interaction. It is easy to envision how this problem can be solved through antigenic variation because this mechanism can generate variants with altered immunodominant epitopes while conserving functionally important parts of the structure. Antigenic variation of the major subunit of gonococcus type IV pili is thought to be a good example of this strategy. Type IV pili are expressed during infection, and antigenic variation is observed in volunteers, although this experimental model is not well suited to studying the contribution of an adaptive immune response because antibiotic treatment is initiated within 4 days of infection (320). Antigenic variation of the major fimbrial subunit generates variation of epitopes exposed at the filament surface while leaving sequences required for its assembly unaltered (96, 271). This mechanism has little effect on the biological function of pili because adherence is mediated by a minor pilus subunit encoded by the *pilC* gene (303). Antigenic variation is thus expected to enable gonococci to evade an immune response directed against the major pilus subunit while maintaining its ability to interact with host cells through type IV pili.

It is less obvious how functionality can be conserved when a phase-variable on/off switch is used to alter the expression of surface antigens. Phase-variable expression of a surface structure that is important for host-pathogen interactions, such as an adhesin, presents the pathogen with a problem. That is, once the host has mounted a specific adaptive response to the adhesin, those cells expressing it (i.e., phase “on” variants) will be cleared by immune mechanisms. Those cells not expressing the adhesin (phase “off” variants) will also be cleared because the adhesin is required for colonization. At a first glance, phase-variable expression of surface structures essential for the host-pathogen interaction therefore appears not to be suited for immune evasion during chronic infection. One possible solution of the problem of using phase variation for immune evasion without losing the ability to adhere to or invade tissue is revealed by the analysis of Opa expression in gonococci. Here, phase variation appears to be paired with functional redundancy of a family of outer membrane proteins to allow the organism to persist in the mucosa of the genitourinary

tract. Gonococci can express up to 12 different Opa proteins, each encoded by a gene whose expression shows phase variation as a result of an SSM mechanism (67). Opa phase variation results in a heterogeneous bacterial population containing cells expressing no, one, or multiple Opa proteins. Most Opa proteins bind to host cell receptors of the CD66 family (CD66a, CD66c, CD66d, and/or CD66e) (38, 44, 45, 108, 109, 375), while one variant binds heparan sulfate (373). Although the receptor specificities of most Opa proteins are similar, phenotypic differences resulting from Opa phase variation can be detected *in vitro* during the interaction of gonococci with epithelial cell lines or with professional phagocytes (67). It has therefore been speculated that the role of Opa phase variation may be the generation of variants that differ in their ability to colonize a particular niche *in vivo*. A correlate of the postulate that a particular combination of Opa proteins may be required for colonization of a particular niche in the host is that this Opa combination would be selected for and would be isolated preferentially from this niche during infection. Volunteer studies show that while the majority of isolates from infected subjects express one or more Opa proteins, no Opa protein is preferentially expressed during early infection in the male urethra (159, 345). These *in vivo* results do not support the view that Opa phase variation functions in the generation of variants with different fitness for colonizing a niche. Instead, these studies support the view that Opa proteins mediate overlapping or redundant functions *in vivo* and that these functions are required during initial colonization of the urethra (159, 345). The overlapping or redundant function mediated by different Opa proteins is likely to be a tight adherence to epithelial cells via CD66 followed by transcytosis of gonococci into the lamina propria (249). The available evidence does not exclude the possibility that the principal role of Opa phase variation is the generation of a repertoire of strains, each expressing different combinations of surface antigens with similar function, thereby allowing newly arising phase variants to evade adaptive immunity while maintaining their ability to colonize the urethra. However, this hypothesis has not yet been tested experimentally in the natural host, because treatment of volunteers needs to be initiated before adaptive immunity fully develops. Thus, it remains to be seen whether the finite combination of gonococcal Opa proteins generated by phase variation is sufficient for immune evasion during chronic infection of mucosal surfaces.

Several other human-adapted pathogens appear to use strategies for persistent colonization of mucosal surfaces that are similar to those employed by the gonococcus. For example, *N. meningitidis* (meningococcus) and *H. influenzae* infect only humans and do not survive in the environment. The vast majority of individuals infected with these organisms are carriers in whom the nasopharynx is colonized asymptotically. Similar to the gonococcus, the meningococcus and *H. influenzae* are both capable of altering all major surface antigens by phase or antigenic variation. These variable antigens include the capsule (122), LOS (167), type IV pili (158, 248, 352), opacity proteins (Opa and Opc) (170, 305, 339), and other outer membrane proteins (201, 290, 366) of meningococcus as well as LOS (296, 391, 392), fimbriae (372), opacity proteins (Oap) (388), and outer membrane proteins involved in iron acquisition (57) of *H. influenzae*. A well-studied example is the me-

ningococcus LOS, which is required for colonization of the nasopharynx, as suggested by animal experiments (406). Analysis of meningococcal LOS biosynthesis provides an intriguing example of how phase variation (i.e., a heritable on/off switch of gene expression) can be used to generate antigenic variation (i.e., changes in the chemical composition) of a surface structure. In this case, expression of several genes (*lgt* genes) encoding glycosyltransferases shows phase variation (11, 156, 157). These glycosyltransferases are required for the expression of terminal LOS structures known as α -chain and β -chain extensions. Variation of α -chain and β -chain extensions dramatically changes the antigenic properties of LOS, thereby forming the basis for its classification into 14 immunotypes, L1 to L14 (167, 220, 314, 421). In many meningococcal isolates, individual genes are missing from the *lgt-1* locus (*lgtABCDE*) and/or the *lgt-3* locus (*lgtG*), thus representing meningococci capable of expressing only a small subset (often 2 or 3) of the 14 known LOS immunotypes (157, 417, 418). It is difficult to envision how switching between a limited repertoire of LOS structures can be sufficient to allow continued immune evasion during chronic infection of the nasopharynx. A mechanism that may contribute to immune evasion is the concealment of antigens by LOS sialylation. The sialylation of α -chain extensions carrying terminal galactose residues (present in the LOS of immunotypes L2, L3, L4, L7, and L9) gives rise to LOS carbohydrate moieties mimicking carbohydrates present in glycosphingolipids of human cells (218, 219). The LOS sialylation is also thought to result in a general down-regulation of antibody and complement binding to the bacterial surface (287). In addition to a possible role in immune evasion, LOS variation has been postulated to be a mechanism that facilitates the adaptation of the meningococcus to environmental changes during its transition from the mucosa of the nasopharynx into the blood. This view is supported by *in vitro* studies showing that the sialylated LOS of immunotypes L3, L7, and L9 confers increased serum resistance but impairs invasion of nasopharyngeal epithelial cells compared to LOS of immunotype L8 (69, 242). Furthermore, an investigation of an outbreak caused by a meningococcus clone (ET-5 complex) capable of expressing six immunotypes (L1, L3, L7, L8, L9, and L10) showed that 97% isolates from patients but only 43% of isolates from healthy carriers expressed immunotypes L3, L7, and L9 (162). It has thus been postulated that colonization of the nasopharyngeal mucosa would select for meningococcus variants expressing a nonsialylated LOS (e.g., immunotype L8) while introduction into the bloodstream would result in selection for sialylated LOS phase variants (e.g., immunotype L3) (167, 236). This hypothesis would predict that isolates from multiple sites within an individual patient (i.e., from the blood and throat) are likely to differ in their immunotype if the strain possesses a repertoire of *lgt* genes that enables it to potentially express immunotype L8 (preferentially isolated from the throat) as well as immunotype L3 (preferentially isolated from the blood). However, a recent analysis of paired isolates (all capable of expressing L3 and L8) from the blood and the throat of individual patients showed no evidence of phase variation within individual pairs, thereby apparently refuting this hypothesis (24). In summary, compelling experimental evidence for any of the proposed *in vivo* roles of LOS phase variation in meningococci is still missing.

Evasion of Cross-Immunity

There are also several well-studied examples of phase-variable surface antigens in members of the family *Enterobacteriaceae*. In these organisms, the potential of phase-variable expression of surface appendages (flagella and fimbriae) for immune evasion is offset by the constitutive expression of LPS, a major surface antigen eliciting protective immune responses. Unlike the LOS of gonococci, meningococci, or *H. influenzae*, the LPS of the members of the *Enterobacteriaceae* carries terminal structures formed by repeating oligosaccharide units (O antigen) that are highly immunogenic. Constitutive expression of these invariant antigens on their surface illustrates that members of the *Enterobacteriaceae* show little potential for evasion of adaptive immune responses during an infection. As a result, these organisms are eventually cleared from host tissues by adaptive immune responses directed against invariant surface antigens and therefore generally cause self-limited infections that leave the host immune to reinfection. The strategies underlying host-pathogen interactions for the *Enterobacteriaceae* are thus fundamentally different from those employed by pathogens causing chronic or recurrent infections by evading adaptive immune responses through variation and concealment of all major surface antigens.

A prototypical example of a pathogen belonging to the family *Enterobacteriaceae* is *Salmonella enterica*, the organism in which the phenomenon of phase variation was first described (6). Based on polymorphisms in their O antigens and their flagellin proteins, *S. enterica* is subdivided into more than 2,000 serotypes. However, unlike meningococcal strains, which are capable of switching between different LOS immunotypes at high frequency, each *S. enterica* serotype expresses an invariant O-antigen type. As a result, after infection with a particular *S. enterica* serotype, a mammalian host acquires immunity against infection with *S. enterica* serotypes expressing the same or similar O antigens. This immunity is based largely on a response to immunodominant O-antigen epitopes that are traditionally used to classify *S. enterica* serotypes into serogroups. For example, the O-antigen repeat units of members of serogroups B and D1 possess an identical trisaccharide backbone (the O12 antigen) but have abequose (the O4 antigen) and tyvelose (the O9 antigen), respectively, as the immunodominant sugar branch (173). The immunodominance of the O4 and O9 antigens in LPS of serogroups B and D1, respectively, is illustrated by analyzing the serological response generated during infection with *S. enterica* serotypes Typhimurium (serogroup B) and Enteritidis (serogroup D1). Exposure of animals to *S. enterica* serotype Enteritidis elicits higher antibody titers against the O9 antigen than against the O12 antigen (14). Similarly, immunization with *S. enterica* serotype Typhimurium results in higher titers against the O4 antigen than against the O12 antigen (333). The importance of immunodominant O-antigen epitopes in eliciting immunity is convincingly demonstrated by challenge experiments performed with mice. Immunization of mice with a *S. enterica* serotype Enteritidis *aroA* mutant (expressing the O9 antigen) elicits protection against challenge with a virulent *S. enterica* serotype Enteritidis strain (expressing the O9 antigen) but not against a virulent strain of *S. enterica* serotype Typhimurium (expressing the O4 antigen). However, cross-protection between the two serotypes is ob-

served when mice immunized with the *S. enterica* serotype Enteritidis *aroA* mutant are challenged with a virulent *S. enterica* serotype Typhimurium mutant that is genetically engineered to express the O9 antigen instead of the O4 antigen (139). O-antigen polymorphism is thus a mechanism that allows *S. enterica* serotypes to evade cross-immunity between members of different serogroups (i.e., between *S. enterica* serotypes expressing different immunodominant O-antigen epitopes) (173).

While *S. enterica* serotype Enteritidis and *S. enterica* serotype Typhimurium evade cross-immunity against LPS by O-antigen polymorphism, other surface structures are well conserved between the two organisms. For instance, fimbriae encoded by the *lpf* operon are composed of a major fimbrial subunit, LpfA, whose primary sequence differs by only one amino acid between the two serotypes (255). Recent evidence suggests that phase-variable expression of the *lpf* operon is required for evasion of cross-immunity between *S. enterica* serotypes expressing different immunodominant O-antigen epitopes. As outlined above, mice immunized with *S. enterica* serotype Typhimurium (serogroup B) do not possess cross-immunity against challenge with *S. enterica* serotype Enteritidis (serogroup D1) (139, 255). However, cross-immunity between *S. enterica* serotype Typhimurium and *S. enterica* serotype Enteritidis is observed if the challenge strain expresses the *lpf* operon constitutively (i.e., once *lpf* fimbrial phase variation has been eliminated by replacing the *lpf* promoter region with the *lac* promoter) (252). The finding that *lpf* phase "off" variants of *S. enterica* serotype Enteritidis can evade cross-immunity against *S. enterica* serotype Typhimurium suggests that they retain considerable virulence because they express alternate attachment factors (255). The genome of *S. enterica* serotype Typhimurium contains 13 fimbrial operons (231), and the synergistic effect of inactivating a subset of these operons provides evidence for redundant functions of the encoded adhesins during infection of mice (367). These data suggest that partial functional redundancy of the 13 fimbrial operons present in *S. enterica* serotype Typhimurium is a prerequisite for effectively using phase variation as a mechanism for immune evasion. The genetic makeup of fimbrial gene sequences in *S. enterica* serotypes is thus reminiscent of the phase-variable expression of functionally related Opa proteins in the gonococcus. However, while it is difficult to envision how the finite combination of Opa proteins generated by phase variation can enable the gonococcus to continuously stay ahead of an adaptive immune response during a chronic infection, evasion of cross-immunity poses a less complicated problem. For example, *S. enterica* serotype Enteritidis (expressing the O9 antigen) has to overcome cross-immunity against fimbrial proteins of *S. enterica* serotype Typhimurium (expressing the O4 antigen) only once (because the host subsequently mounts an adaptive response to its O9 antigen), a task that appears manageable by a phase-variable on/off switch for the individual fimbrial operons. In this context, the recent finding that each *S. enterica* serotype possesses a distinct repertoire of fimbrial operons appears relevant, because this genetic design probably facilitates evasion of cross-immunity against fimbrial proteins between different serotypes (357). Their role in evasion of cross-immunity provides an attractive explanation of why genomes of *S. enterica* serotypes contain large but distinct repertoires of fimbrial op-

erons that are regulated by phase variation and exhibit partial functional redundancy. To understand the importance of fimbrial phase variation, it is thus necessary to review the biological significance of evading cross-immunity.

Evasion of cross-immunity appears to provide a significant selective advantage for *S. enterica* serotypes during coexistence in their animal reservoirs. A major source of direct competition between *S. enterica* serotypes occupying the same ecological niche (i.e., the intestine of a mammalian host species) is the host immune response, which may effectively limit the available resources (i.e., susceptible individuals suitable for transmission) (115). Mathematical models predict that cross-immunity between *S. enterica* serotypes which share immunodominant O antigen epitopes will result in competition, with the likely outcome being that the most successful (in terms of transmission success) serotype will outcompete the others in a particular host population (5, 173). However, *S. enterica* serotypes can coexist within a host population by evading cross-immunity through O-antigen polymorphism. Thus, the host immune response is predicted to reduce populations of different *S. enterica* serotypes sharing an immunodominant O antigen to a single strain, while coexistence of two or more serotypes in a host population is possible, if they evade cross-immunity by O-antigen polymorphism (i.e., by expressing different immunodominant O-antigen epitopes) (173). These theoretical predictions are in good agreement with the results of epidemiological studies showing that *S. enterica* serotypes causing the majority of cases of disease in a mammalian reservoir possess different immunodominant O-antigen epitopes (i.e., belong to different serogroups). For example, *S. enterica* serotype Dublin (serogroup D1) and *S. enterica* serotype Typhimurium (serogroup B) are associated with the majority of reported disease incidents in cattle (198, 336–338). *S. enterica* serotype Choleraesuis (serogroup C1), *S. enterica* serotype Typhimurium (serogroup B), and *S. enterica* serotype Dublin (serogroup D1) cause the majority of illnesses in pigs (88, 198, 336, 337). Furthermore, strictly host-adapted *S. enterica* serotypes causing typhoid fever coexist in the human population, and each expresses a different immunodominant O-antigen epitope. These include *S. enterica* serotype Typhi (serogroup D1), *S. enterica* serotype Paratyphi A (serogroup A), *S. enterica* serotype Paratyphi B (serogroup B), and *S. enterica* serotype Paratyphi C (serogroup C1) (173). These epidemiological data thus support the view that the host immune response to immunodominant O-antigen epitopes has shaped the population structure of *S. enterica* serotypes. The value of evading cross-immunity with a well-adapted competitor becomes clear when considering the alternative outcome. For example, *S. enterica* serotype Paratyphi A is human adapted and does not have an animal reservoir. If *S. enterica* serotype Paratyphi A expressed the same immunodominant O antigen as *S. enterica* serotype Typhi, the serotype with the greater transmission success (probably *S. enterica* serotype Typhi) would over time outcompete the other serotype in the human population. This would result in the elimination of *S. enterica* serotype Paratyphi A from its only reservoir and therefore would lead to its eradication. By expressing a different immunodominant O antigen (that of serogroup A), *S. enterica* serotype Paratyphi A is able to evade competition with the highly specialized *S. enterica* serotype Typhi (serogroup D1) and avoid eradication. The

evolutionary cost of this strategy is that *S. enterica* serotype Paratyphi A has to compete with other *S. enterica* serotypes of serogroup A that circulate in the human population. The evolutionary gain (avoiding eradication) clearly outweighs the costs, since there is no other human-adapted *Salmonella* serotype of serogroup A that could provide stiff competition with *S. enterica* serotype Paratyphi A. In conclusion, evasion of cross-immunity may represent one of the driving forces for the regulation of fimbrial expression by phase variation and for the maintenance of O-antigen polymorphism among *S. enterica* serotypes (147, 173).

DNA Restriction-Modification Systems

Consistent with a role of phase variation in host-pathogen interactions, most phase-variable genes are predicted to be involved in the biosynthesis of surface structures. Notable exceptions are genes encoding R/M enzymes. Phase-variable expression of R/M enzymes has been found in a variety of bacterial pathogens, including *S. pneumoniae* (349), *M. pulmonis* (86), *H. pylori* (309), *P. haemolytica* (304), and *H. influenzae* (66). However, the significance of R/M enzyme phase variation is currently unclear. Phenotypic switching of putative R/M enzymes in *H. pylori* is induced on contact with human gastric cells (76). In *M. pulmonis* a high level of R/M enzyme (HsdS) variation is induced in vivo during infection of the rat trachea (112). These observations appear to support a role for R/M enzyme variation during host pathogen interaction. This interpretation appears less convincing in light of recent data demonstrating that HsdS variation and phase variation of the *M. pulmonis* variable surface protein (VsaA) are mediated by the same recombinase (HvsR) (330). The link between HsdS and VsaA phase variation in *M. pulmonis* suggests that isolation of variants in vivo may result from selection for surface antigen variants, not R/M enzyme variants. Thus, the significance of R/M enzyme variation for host-pathogen interactions, if any, remains to be determined.

DIAGNOSTIC AND EXPERIMENTAL SIGNIFICANCE OF PHASE VARIATION

Ideally, a diagnostic test will identify a particular species, strain, or isolate, independent of growth conditions, number of generations grown, individual colony examined, or source of the sample. Similarly, for vaccine design, proteins or processes should be preferentially targeted that are expressed in all isolates and in each individual cell and that show no antigenic variation. Laboratory experiments in general also depend on homogenous cultures for reproducible results. The impact of phase variation for diagnostics tests and vaccine design, as well as for experimental design and interpretation, therefore lies in its potential to generate a rapid phenotypic variability in a clonal population. Some examples are discussed below to illustrate these concerns.

For a time, a lack of reproducibility occurred in laboratory tests for toxin production by *S. pyogenes* and in the results of cellular invasion tests, but could not be clarified. This issue was resolved when it became apparent that toxin production and invasive phenotype in this species is under the control of phase variation. This variable toxin production must also be taken

into account in studies that aim to associate toxin production with toxic shock (52). A second example concerns serosubtyping in *N. meningitidis*, which is based on the P1 protein. This protein can be expressed at different levels as a result of SSM-mediated phase variation. Bart and others showed that among *N. meningitidis* strains, phase variation of the *porA* gene, encoding P1, accounted for most of the nonreacting strains (16, 365, 366). Thus, serosubtyping based on expression of a phase-variable protein can result in an underestimate of the rise of a hyperendemic clone. These examples illustrate that the interpretation of experimental results, establishing correlations between laboratory results and clinical symptoms, and epidemiological studies can all be complicated by phase-variable gene expression in the bacterium.

Phase variation may also be subject to regulation, and the environment may drive selection against a particular expression state, which is particularly evident in an animal host. This can result in a different phenotype for cells cultured in the laboratory and those in the host. For example, expression of MR/P fimbriae in *Proteus mirabilis* is strongly favored during infection whereas phase variation is readily apparent in vitro (416). Differences may also arise due to the choice of sampling site or tissue in the host. These concerns have been specifically mentioned in the analysis of the role of the Lewis antigen in *H. pylori* infections (384). *H. influenzae* isolates with ChoP-decorated LOS are successful colonizers in the nasopharynx, whereas the "off" phase is more successful in serum (393), and phase variation even occurs at the microcolony level in *N. meningitidis* in skin lesions (123). Thus, the phenotype and genotype of single colonies of laboratory-passaged clinical isolates should be extrapolated with care as representing the bacterial population of the same isolate in a patient.

As discussed in "Biological significance of phase variation" (above), antigenic variation and phase variation facilitate both persistence of single isolates and coexistence of serotypes in a host. Therefore, challenges may be encountered when vaccines are developed that target proteins or moieties that undergo antigenic or phase variation, but phase-variable expression of a target protein does not necessarily preclude its use as a vaccine target. Expression of type 1 fimbriae in *E. coli* is under the control of phase variation. Nevertheless, an experimental vaccine based on the FimH adhesin of these fimbriae is effective in preventing *E. coli* urinary tract infections in animal models, specifically bladder colonization and cystitis (reviewed reference 193). In this animal model, a bias to the "on" phase exists in the urinary tract and a decreased efficiency in colonization exists in cells in the "off" phase (113, 114, 205). Thus, the loss of expression of the vaccine target (phase "off") in this case may have coincided with a decreased ability to establish an infection, contributing to the efficacy of this vaccine.

In this review, rapid variation in the length of short DNA sequence repeats has been emphasized as a mechanism to create genotypic and phenotypic variation among a clonal population. Changes in repetitive sequences, however, are increasingly used as genetic markers for strain identification and phylogenetic analysis using multiple-locus variable-number tandem repeat analysis (MLVA) (359). MLVA has been developed for various pathogens, including *Y. pestis*, *Francisella tularensis*, and *Borrelia* spp., and also was one of the approaches used by the Center for Disease Control and Preven-

tion for determining the presence of *Bacillus anthracis* in a large volume of environmental samples in 2001 (93, 94, 133, 175). SSM-dependent phase variation has not been identified in these particular species.

Very high or very low variation rates will complicate the use of repeat sequences for MLVA. Factors that influence the stability of repeat sequences are slowly being identified. These include the length of the repeat unit and the number of repeats, the sequence itself, and the sequence context (66, 291, 360, 361). The genetic background also influences stability (275). Keim and colleagues have analyzed the stability of many repetitive sequences in *E. coli*, *Y. pestis*, and *B. anthracis* and have determined that the stability is dramatically different between loci. This emphasizes the importance of using multiple loci in MLVA. Rapid variations, as high as 6×10^{-4} , are considered useful in distinguishing between closely related samples, whereas variations that occur at $<10^{-5}$ are more useful for less closely related samples (P. Keim, personal communication). Switching frequencies of phase-variable genes frequently occur at rates of 10^{-4} or higher (18, 40). However, at 10^{-4} a fairly stable clonal population is still obtained in the absence of selective pressure (308). Thus, some repeat sequences that allow MLVA-based analysis may also facilitate phase variation, and in the presence of selective pressures they facilitate an adaptive change in the composition of the clonal population. Continued efforts to define the stability of repeat sequences and the mechanisms involved will prove valuable in predicting phase-variable genes as well as enhancing the development of diagnostic tools.

ACKNOWLEDGMENTS

Work in M.V.D.W.'s laboratory is supported by National Science Foundation grant MCB00751, and work in A.B.'s laboratory is supported by USDA/NRICGP grant 2002-35204-12247 and Public Health Service grants AI40124 and AI44170.

We thank I. Blomfield, P. Keim, D. Low, and A. Hernday for helpful discussions and E. Binet and A. Wallecha for critical reading of the manuscript.

REFERENCES

1. Abraham, J. M., C. S. Freitag, J. R. Clements, and B. I. Eisenstein. 1985. An invertible element of DNA controls phase variation of type 1 fimbriae of *Escherichia coli*. Proc. Natl. Acad. Sci. USA **82**:5724-5727.
2. Akerley, B. J., P. A. Cotter, and J. F. Miller. 1995. Ectopic expression of the flagellar regulon alters development of the *Bordetella*-host interaction. Cell **80**:611-620.
3. Al-Hasani, K., K. Rajakumar, D. Bulach, R. Robins-Browne, B. Adler, and H. Sakellaris. 2001. Genetic organization of the she pathogenicity island in *Shigella flexneri* 2a. Microb. Pathog. **30**:1-8.
4. Alm, R. A., L. S. Ling, D. T. Moir, B. L. King, E. D. Brown, P. C. Doig, D. R. Smith, B. Noonan, B. C. Guild, B. L. deJonge, G. Carmel, P. J. Tummino, A. Caruso, M. Uria-Nickelsen, D. M. Mills, C. Ives, R. Gibson, D. Merberg, S. D. Mills, Q. Jiang, D. E. Taylor, G. F. Vovis, and T. J. Trust. 1999. Genomic-sequence comparison of two unrelated isolates of the human gastric pathogen *Helicobacter pylori*. Nature **397**:176-180.
5. Anderson, R. M. 1995. Evolutionary pressures in the spread and persistence of infectious agents in vertebrate populations. Parasitology **111**:S15-S31.
6. Andrewes, F. W. 1922. Studies in group-agglutination. I. The *Salmonella* group and its antigenic structure. J. Pathol. Bacteriol. **25**:505-521.
7. Appelmelk, B. J., S. L. Martin, M. A. Monteiro, C. A. Clayton, A. A. McCollm, P. Zheng, T. Verboom, J. J. Maaskant, D. H. van den Eijnden, C. H. Hokke, M. B. Perry, C. M. Vandenbroucke-Grauls, and J. G. Kusters. 1999. Phase variation in *Helicobacter pylori* lipopolysaccharide due to changes in the lengths of poly(C) tracts in α_3 -fucosyltransferase genes. Infect. Immun. **67**:5361-5366.
8. Appelmelk, B. J., M. A. Monteiro, S. L. Martin, A. P. Moran, and C. M. Vandenbroucke-Grauls. 2000. Why *Helicobacter pylori* has Lewis antigens. Trends Microbiol. **8**:565-570.
9. Bacon, D. J., C. M. Szymanski, D. H. Burr, R. P. Silver, R. A. Alm, and P.

- Guerry. 2001. A phase-variable capsule is involved in virulence of *Campylobacter jejuni* 81–176. *Mol. Microbiol.* **40**:769–777.
10. Banerjee, A., R. Wang, S. L. Supernavage, S. K. Ghosh, J. Parker, N. F. Ganesh, P. G. Wang, S. Gulati, and P. A. Rice. 2002. Implications of phase variation of a gene (*pgtA*) encoding a pilin galactosyl transferase in gonococcal pathogenesis. *J. Exp. Med.* **196**:147–162.
 11. Banerjee, A., R. Wang, S. N. Uljon, P. A. Rice, E. C. Gotschlich, and D. C. Stein. 1998. Identification of the gene (*lgtG*) encoding the lipooligosaccharide beta chain synthesizing glucosyl transferase from *Neisseria gonorrhoeae*. *Proc. Natl. Acad. Sci. USA* **95**:10872–10877.
 12. Barbour, A. 2002. Antigenic variation by relapsing fever *Borrelia* species and other bacterial pathogens, p. 972–994. In N. L. Craig, R. Craigie, M. Gellert, and A. M. Lambowitz (ed.), *Mobile DNA II*. ASM Press, Washington, D.C.
 13. Barbour, A. G., and S. F. Hayes. 1986. Biology of *Borrelia* species. *Microbiol. Rev.* **50**:381–400.
 14. Barrow, P. A., A. Berchieri, Jr., and O. al-Haddad. 1992. Serological response of chickens to infection with *Salmonella gallinarum*-*S. pullorum* detected by enzyme-linked immunosorbent assay. *Avian Dis.* **36**:227–236.
 15. Barry, J. D., and R. McCulloch. 2001. Antigenic variation in trypanosomes: enhanced phenotypic variation in a eukaryotic parasite. *Adv Parasitol.* **49**:1–70.
 16. Bart, A., J. Dankert, and A. van der Ende. 1999. Antigenic variation of the class I outer membrane protein in hyperendemic *Neisseria meningitidis* strains in the Netherlands. *Infect. Immun.* **67**:3842–3846.
 17. Bartlett, D. H., and M. Silverman. 1989. Nucleotide sequence of IS492, a novel insertion sequence causing variation in extracellular polysaccharide production in the marine bacterium *Pseudomonas atlantica*. *J. Bacteriol.* **171**:1763–1766.
 18. Bayliss, C. D., T. van de Ven, and E. R. Moxon. 2002. Mutations in *poll* but not *mutSLH* destabilize *Haemophilus influenzae* tetranucleotide repeats. *EMBO J.* **21**:1465–1476.
 19. Behrens, A., M. Heller, H. Kirchhoff, D. Yogeve, and R. Rosengarten. 1994. A family of phase- and size-variant membrane surface lipoprotein antigens (Vsp)s of *Mycoplasma bovis*. *Infect. Immun.* **62**:5075–5084.
 20. Behrens, A., F. Poumarat, D. Le Grand, M. Heller, and R. Rosengarten. 1996. A newly identified immunodominant membrane protein (pMB67) involved in *Mycoplasma bovis* surface antigenic variation. *Microbiology* **142**:2463–2470.
 21. Belland, R. J. 1991. H-DNA formation by the coding repeat elements of neisserial *opa* genes. *Mol. Microbiol.* **5**:2351–2360.
 22. Belland, R. J., S. G. Morrison, J. H. Carlson, and D. M. Hogan. 1997. Promoter strength influences phase variation of neisserial *opa* genes. *Mol. Microbiol.* **23**:123–135.
 23. Belland, R. J., S. G. Morrison, P. van der Ley, and J. Swanson. 1989. Expression and phase variation of gonococcal PII genes in *Escherichia coli* involves ribosomal frameshifting and slipped-strand mispairing. *Mol. Microbiol.* **3**:777–786.
 24. Berrington, A. W., Y. C. Tan, Y. Srihanta, B. Kuipers, P. van der Ley, I. R. Peak, and M. P. Jennings. 2002. Phase variation in meningococcal lipooligosaccharide biosynthesis genes. *FEMS Immunol. Med. Microbiol.* **34**:267–275.
 25. Beutler, B. 2002. TLR4 as the mammalian endotoxin sensor. *Curr. Top. Microbiol. Immunol.* **270**:109–120.
 26. Bhugra, B., L. L. Voelker, N. Zou, H. Yu, and K. Dybvig. 1995. Mechanism of antigenic variation in *Mycoplasma pulmonis*: interwoven, site-specific DNA inversions. *Mol. Microbiol.* **18**:703–714.
 27. Blaser, M. J., and Z. Pei. 1993. Pathogenesis of *Campylobacter fetus* infections: critical role of high-molecular-weight S-layer proteins in virulence. *J. Infect. Dis.* **167**:372–377.
 28. Blom, A. M., A. Rytkonen, P. Vasquez, G. Lindahl, B. Dahlback, and A. B. Jonsson. 2001. A novel interaction between type IV pili of *Neisseria gonorrhoeae* and the human complement regulator C4B-binding protein. *J. Immunol.* **166**:6764–6770.
 29. Blomfield, I., and M. Van der Woude. 2002. Regulation and function of phase variation in *Escherichia coli*, p. 89–114. In M. Wilson (ed.), *Bacterial adhesion to host tissues: mechanisms and consequences*. Cambridge University Press, Cambridge, United Kingdom.
 30. Blomfield, I. C. 2002. DNA rearrangements and gene expression. *Soc. Gen. Microbiol. Symp.* **61**:57–72.
 31. Blomfield, I. C. 2001. The regulation of pap and type 1 fimbriation in *Escherichia coli*. *Adv. Microb. Physiol.* **45**:1–49.
 32. Blomfield, I. C., P. J. Calie, K. J. Eberhardt, M. S. McClain, and B. I. Eisenstein. 1993. Lrp stimulates phase variation of type 1 fimbriation in *Escherichia coli* K-12. *J. Bacteriol.* **175**:27–36.
 33. Blyn, L. B., B. A. Braaten, and D. A. Low. 1990. Regulation of *pap* pilin phase variation by a mechanism involving differential *dam* methylation states. *EMBO J.* **9**:4045–4054.
 34. Boneca, I. G., H. de Reuse, J. C. Epinat, M. Pupin, A. Labigne, and I. Moszer. 2003. A revised annotation and comparative analysis of *Helicobacter pylori* genomes. *Nucleic Acids Res.* **31**:1704–1714.
 35. Bonifield, H. R., and K. T. Hughes. 2003. Flagellar phase variation in *Salmonella enterica* is mediated by a posttranscriptional control mechanism. *J. Bacteriol.* **185**:3567–3574.
 36. Bormann, N. E., and P. P. Cleary. 1997. Transcriptional analysis of *mga*, a regulatory gene in *Streptococcus pyogenes*: identification of monocistronic and bicistronic transcripts that phase vary. *Gene* **200**:125–134.
 37. Borst, P., and S. Ulbert. 2001. Control of VSG gene expression sites. *Mol. Biochem. Parasitol.* **114**:17–27.
 38. Bos, M. P., F. Grunert, and R. J. Belland. 1997. Differential recognition of members of the carcinoembryonic antigen family by Opa variants of *Neisseria gonorrhoeae*. *Infect. Immun.* **65**:2353–2361.
 39. Boyd, E. F., and H. Brussow. 2002. Common themes among bacteriophage-encoded virulence factors and diversity among the bacteriophages involved. *Trends Microbiol.* **10**:521–529.
 40. Braaten, B. A., X. Nou, L. S. Kaltenbach, and D. A. Low. 1994. Methylation patterns in pap regulatory DNA control pyelonephritis-associated pili phase variation in *E. coli*. *Cell* **76**:577–588.
 41. Caldwell, M. B., P. Guerry, E. C. Lee, J. P. Burans, and R. I. Walker. 1985. Reversible expression of flagella in *Campylobacter jejuni*. *Infect. Immun.* **50**:941–943.
 42. Carson, S. D., B. Stone, M. Beucher, J. Fu, and P. F. Sparling. 2000. Phase variation of the gonococcal siderophore receptor FetA. *Mol. Microbiol.* **36**:585–593.
 43. Chen, C. J., C. Elkins, and P. F. Sparling. 1998. Phase variation of hemoglobin utilization in *Neisseria gonorrhoeae*. *Infect. Immun.* **66**:987–993.
 44. Chen, T., and E. C. Gotschlich. 1996. CGM1a antigen of neutrophils, a receptor of gonococcal opacity proteins. *Proc. Natl. Acad. Sci. USA* **93**:14851–14856.
 45. Chen, T., F. Grunert, A. Medina-Marino, and E. C. Gotschlich. 1997. Several carcinoembryonic antigens (CD66) serve as receptors for gonococcal opacity proteins. *J. Exp. Med.* **185**:1557–1564.
 46. Ciacci-Woolwine, F., I. C. Blomfield, S. H. Richardson, and S. B. Mizel. 1998. *Salmonella* flagellin induces tumor necrosis factor alpha in a human promonocytic cell line. *Infect. Immun.* **66**:1127–1134.
 47. Citti, C., M. F. Kim, and K. S. Wise. 1997. Elongated versions of Vlp surface lipoproteins protect *Mycoplasma hyorhinis* escape variants from growth-inhibiting host antibodies. *Infect. Immun.* **65**:1773–1785.
 48. Citti, C., and R. Rosengarten. 1997. *Mycoplasma* genetic variation and its implication for pathogenesis. *Wien. Klin. Wochenschr.* **109**:562–568.
 49. Citti, C., R. Watson-McKown, M. Drosses, and K. S. Wise. 2000. Gene families encoding phase- and size-variable surface lipoproteins of *Mycoplasma hyorhinis*. *J. Bacteriol.* **182**:1356–1363.
 50. Citti, C., and K. S. Wise. 1995. *Mycoplasma hyorhinis* vlp gene transcription: critical role in phase variation and expression of surface lipoproteins. *Mol. Microbiol.* **18**:649–660.
 51. Clarke, S. C., M. A. Diggle, P. Molling, M. Unemo, and P. Olcen. 2003. Analysis of PorA variable region 3 in meningococci: implications for vaccine policy? *Vaccine* **21**:2468–2473.
 52. Cleary, P. P., L. McLandsborough, L. Ikeda, D. Cue, J. Krawczak, and H. Lam. 1998. High-frequency intracellular infection and erythrogenic toxin A expression undergo phase variation in M1 group A streptococci. *Mol. Microbiol.* **28**:157–167.
 53. Clegg, S., L. S. Hancox, and K. S. Yeh. 1996. *Salmonella typhimurium* fimbrial phase variation and FimA expression. *J. Bacteriol.* **178**:542–545.
 54. Clegg, S., and K. T. Hughes. 2002. FimZ is a molecular link between sticking and swimming in *Salmonella enterica* serovar Typhimurium. *J. Bacteriol.* **184**:1209–1213.
 55. Coffey, E. M., and W. C. Eveland. 1967. Experimental relapsing fever initiated by *Borrelia hermsii*. I. Identification of major serotypes by immunofluorescence. *J. Infect. Dis.* **117**:23–28.
 56. Coffey, E. M., and W. C. Eveland. 1967. Experimental relapsing fever initiated by *Borrelia hermsii*. II. Sequential appearance of major serotypes in the rat. *J. Infect. Dis.* **117**:29–34.
 57. Cope, L. D., Z. Hrkal, and E. J. Hansen. 2000. Detection of phase variation in expression of proteins involved in hemoglobin and hemoglobin-haptoglobin binding by nontypeable *Haemophilus influenzae*. *Infect. Immun.* **68**:4092–4101.
 58. Cornelissen, C. N., J. E. Anderson, I. C. Boulton, and P. F. Sparling. 2000. Antigenic and sequence diversity in gonococcal transferrin-binding protein A. *Infect. Immun.* **68**:4725–4735.
 59. Correnti, J., V. Munster, T. Chan, and M. Woude Mv. 2002. Dam-dependent phase variation of Ag43 in *Escherichia coli* is altered in a *seqA* mutant. *Mol. Microbiol.* **44**:521–532.
 60. Cotter, P. A., and J. F. Miller. 1997. A mutation in the *Bordetella bronchiseptica* *bvgS* gene results in reduced virulence and increased resistance to starvation, and identifies a new class of Bvg-regulated antigens. *Mol. Microbiol.* **24**:671–685.
 61. Cowley, S. C., S. V. Myltseva, and F. E. Nano. 1996. Phase variation in *Francisella tularensis* affecting intracellular growth, lipopolysaccharide antigenicity and nitric oxide production. *Mol. Microbiol.* **20**:867–874.
 62. Crost, C., A. Garrivier, J. Harel, and C. Martin. 2003. Leucine-responsive regulatory protein-mediated repression of *clp* (encoding CS31A) expression by L-leucine and L-alanine in *Escherichia coli*. *J. Bacteriol.* **185**:1886–1894.

63. Danaher, R. J., J. C. Levin, D. Arking, C. L. Burch, R. Sandlin, and D. C. Stein. 1995. Genetic basis of *Neisseria gonorrhoeae* lipooligosaccharide antigenic variation. *J. Bacteriol.* **177**:7275–7279.
64. Danese, P. N., L. A. Pratt, S. Dove, and R. Kolter. 2000. The outer-membrane protein, Ag43, mediates cell-to-cell interactions within *E. coli* biofilms. *Mol. Microbiol.* **37**:424–432.
65. Dawid, S., S. J. Barenkamp, and J. W. St Geme, 3rd. 1999. Variation in expression of the *Haemophilus influenzae* HMW adhesins: a prokaryotic system reminiscent of eukaryotes. *Proc. Natl. Acad. Sci. USA* **96**:1077–1082.
66. De Bolle, X., C. D. Bayliss, D. Field, T. van de Ven, N. J. Saunders, D. W. Hood, and E. R. Moxon. 2000. The length of a tetranucleotide repeat tract in *Haemophilus influenzae* determines the phase variation rate of a gene with homology to type III DNA methyltransferases. *Mol. Microbiol.* **35**:211–222.
67. Dehio, C., S. D. Gray-Owen, and T. F. Meyer. 1998. The role of neisserial Opa proteins in interactions with host cells. *Trends Microbiol.* **6**:489–495.
68. Deitsch, K. W., E. R. Moxon, and T. E. Welles. 1997. Shared themes of antigenic variation and virulence in bacterial, protozoal, and fungal infections. *Microbiol. Mol. Biol. Rev.* **61**:281–293.
69. de Vries, F. P., A. van der Ende, J. P. van Putten, and J. Dankert. 1996. Invasion of primary nasopharyngeal epithelial cells by *Neisseria meningitidis* is controlled by phase variation of multiple surface antigens. *Infect. Immun.* **64**:2998–3006.
70. De Vries, N., D. Duinsbergen, E. J. Kuipers, R. G. Pot, P. Wiesenecker, C. W. Penn, A. H. Van Vliet, C. M. Vandembroucke-Grauls, and J. G. Kusters. 2002. Transcriptional phase variation of a type III restriction-modification system in *Helicobacter pylori*. *J. Bacteriol.* **184**:6615–6623.
71. Deziel, E., Y. Comeau, and R. Villemur. 2001. Initiation of biofilm formation by *Pseudomonas aeruginosa* 57RP correlates with emergence of hyperpiliated and highly adherent phenotypic variants deficient in swimming, swarming, and twitching motilities. *J. Bacteriol.* **183**:1195–1204.
72. Diderichsen, B. 1980. *flu*, a metastable gene controlling surface properties of *Escherichia coli*. *J. Bacteriol.* **141**:858–867.
73. Diker, K. S., G. Hascelik, and M. Akan. 1992. Reversible expression of flagella in *Campylobacter* spp. *FEMS Microbiol. Lett.* **78**:261–264.
74. Dobrindt, U., and J. Hacker. 2001. Regulation of tRNA^{Leu}-encoding gene *leuX* that is associated with a pathogenicity island in the uropathogenic *Escherichia coli* strain 536. *Mol. Genet. Genomics* **265**:895–904.
75. Dobrindt, U., K. Piechaczek, A. Schierhorn, G. Fischer, M. Hecker, and J. Hacker. 2002. Influence of the *leuX*-encoded tRNA^{Leu} on the regulation of gene expression in pathogenic *Escherichia coli*. *J. Mol. Microbiol. Biotechnol.* **4**:205–209.
76. Donahue, J. P., R. M. Peek, L. J. Van Doorn, S. A. Thompson, Q. Xu, M. J. Blaser, and G. G. Miller. 2000. Analysis of *iceA1* transcription in *Helicobacter pylori*. *Helicobacter* **5**:1–12.
77. Donelson, J. E. 2003. Antigenic variation and the African trypanosome genome. *Acta Trop.* **85**:391–404.
78. Dorman, C. J., and C. F. Higgins. 1987. Fimbrial phase variation in *Escherichia coli*: dependence on integration host factor and homologies with other site-specific recombinases. *J. Bacteriol.* **169**:3840–3843.
79. Dove, S. L., and C. J. Dorman. 1994. The site-specific recombination system regulating expression of the type 1 fimbrial subunit gene of *Escherichia coli* is sensitive to changes in DNA supercoiling. *Mol. Microbiol.* **14**:975–988.
80. Dubreuil, J. D., S. M. Logan, S. Cabbage, D. N. Eidhin, W. D. McCubbin, C. M. Kay, T. J. Beveridge, F. G. Ferris, and T. J. Trust. 1988. Structural and biochemical analyses of a surface array protein of *Campylobacter fetus*. *J. Bacteriol.* **170**:4165–4173.
81. Dworkin, J., and M. J. Blaser. 1996. Generation of *Campylobacter fetus* S-layer protein diversity utilizes a single promoter on an invertible DNA segment. *Mol. Microbiol.* **19**:1241–1253.
82. Dworkin, J., and M. J. Blaser. 1997. Molecular mechanisms of *Campylobacter fetus* surface layer protein expression. *Mol. Microbiol.* **26**:433–440.
83. Dworkin, J., and M. J. Blaser. 1997. Nested DNA inversion as a paradigm of programmed gene rearrangement. *Proc. Natl. Acad. Sci. USA* **94**:985–990.
84. Dworkin, J., O. L. Shedd, and M. J. Blaser. 1997. Nested DNA inversion of *Campylobacter fetus* S-layer genes is *recA* dependent. *J. Bacteriol.* **179**:7523–7529.
85. Dybvig, K. 1993. DNA rearrangements and phenotypic switching in prokaryotes. *Mol. Microbiol.* **10**:465–471.
86. Dybvig, K., R. Sitaraman, and C. T. French. 1998. A family of phase-variable restriction enzymes with differing specificities generated by high-frequency gene rearrangements. *Proc. Natl. Acad. Sci. USA* **95**:13923–13928.
87. Dybvig, K., and H. Yu. 1994. Regulation of a restriction and modification system via DNA inversion in *Mycoplasma pulmonis*. *Mol. Microbiol.* **12**:547–560.
88. Edwards, P. R., and D. W. Bruner. 1943. The occurrence and distribution of *Salmonella* types in the United States. *J. Infect. Dis.* **72**:58–67.
89. Eisenstein, B. I. 1988. Type 1 fimbriae of *Escherichia coli*: genetic regulation, morphogenesis, and role in pathogenesis. *Rev. Infect. Dis.* **10**(Suppl. 2):S341–S344.
90. Eisenstein, B. I., D. S. Sweet, V. Vaughn, and D. I. Friedman. 1987. Integration host factor is required for the DNA inversion that controls phase variation in *Escherichia coli*. *Proc. Natl. Acad. Sci. USA* **84**:6506–6510.
91. El-Labany, S., B. K. Sohanpal, M. Lahooti, R. Akerman, and I. C. Blomfield. 2003. Distant *cis*-active sequences and sialic acid control the expression of *fimB* in *Escherichia coli* K-12. *Mol. Microbiol.* **49**:1109–1118.
92. Enos-Berlage, J. L., and L. L. McCarter. 2000. Relation of capsular polysaccharide production and colonial cell organization to colony morphology in *Vibrio parahaemolyticus*. *J. Bacteriol.* **182**:5513–5520.
93. Farlow, J., D. Postic, K. L. Smith, Z. Jay, G. Baranton, and P. Keim. 2002. Strain typing of *Borrelia burgdorferi*, *Borrelia afzelii*, and *Borrelia garinii* by using multiple-locus variable-number tandem repeat analysis. *J. Clin. Microbiol.* **40**:4612–4618.
94. Farlow, J., K. L. Smith, J. Wong, M. Abrams, M. Lytle, and P. Keim. 2001. *Francisella tularensis* strain typing using multiple-locus, variable-number tandem repeat analysis. *J. Clin. Microbiol.* **39**:3186–3192.
95. Fleischmann, R. D., M. D. Adams, O. White, R. A. Clayton, E. F. Kirkness, A. R. Kerlavage, C. J. Bult, J. F. Tomb, B. A. Dougherty, J. M. Merrick, et al. 1995. Whole-genome random sequencing and assembly of *Haemophilus influenzae* Rd. *Science* **269**:496–512.
96. Forest, K. T., and J. A. Tainer. 1997. Type-4 pilus-structure: outside to inside and top to bottom—a minireview. *Gene* **192**:165–169.
97. Forsman, K., M. Goransson, and B. E. Uhlin. 1989. Autoregulation and multiple DNA interactions by a transcriptional regulatory protein in *E. coli* pili biogenesis. *EMBO J.* **8**:1271–1277.
98. Ftacek, P., L. Skultety, and R. Toman. 2000. Phase variation of *Coxiella burnetii* strain Priscilla: influence of this phenomenon on biochemical features of its lipopolysaccharide. *J. Endotoxin Res.* **6**:369–376.
99. Fussenegger, M., T. Rudel, R. Barten, R. Ryll, and T. F. Meyer. 1997. Transformation competence and type-4 pilus biogenesis in *Neisseria gonorrhoeae*—a review. *Gene* **192**:125–134.
100. Gabig, M., A. Herman-Antosiewicz, M. Kwiatkowska, M. Los, M. S. Thomas, and G. Wegrzyn. 2002. The cell surface protein Ag43 facilitates phage infection of *Escherichia coli* in the presence of bile salts and carbohydrates. *Microbiology* **148**:1533–1542.
101. Gally, D. L., J. A. Bogan, B. I. Eisenstein, and I. C. Blomfield. 1993. Environmental regulation of the *fim* switch controlling type 1 fimbrial phase variation in *Escherichia coli* K-12: effects of temperature and media. *J. Bacteriol.* **175**:6186–6193.
102. Gally, D. L., J. Leathart, and I. C. Blomfield. 1996. Interaction of FimB and FimE with the *fim* switch that controls the phase variation of type 1 fimbriae in *Escherichia coli* K-12. *Mol. Microbiol.* **21**:725–738.
103. Gally, D. L., T. J. Rucker, and I. C. Blomfield. 1994. The leucine-responsive regulatory protein binds to the *fim* switch to control phase variation of type 1 fimbrial expression in *Escherichia coli* K-12. *J. Bacteriol.* **176**:5665–5672.
104. Ge, Z., and D. E. Taylor. 1999. Contributions of genome sequencing to understanding the biology of *Helicobacter pylori*. *Annu. Rev. Microbiol.* **53**:353–387.
105. Gilbert, M., M. F. Karwaski, S. Bernatchez, N. M. Young, E. Taboada, J. Michniewicz, A. M. Cunningham, and W. W. Wakarchuk. 2002. The genetic bases for the variation in the lipo-oligosaccharide of the mucosal pathogen, *Campylobacter jejuni*. Biosynthesis of sialylated ganglioside mimics in the core oligosaccharide. *J. Biol. Chem.* **277**:327–337.
106. Grant, C. C., M. E. Konkel, W. Cieplak, Jr., and L. S. Tompkins. 1993. Role of flagella in adherence, internalization, and translocation of *Campylobacter jejuni* in nonpolarized and polarized epithelial cell cultures. *Infect. Immun.* **61**:1764–1771.
107. Gravekamp, C., B. Rosner, and L. C. Madoff. 1998. Deletion of repeats in the alpha C protein enhances the pathogenicity of group B streptococci in immune mice. *Infect. Immun.* **66**:4347–4354.
108. Gray-Owen, S. D., C. Dehio, A. Haude, F. Grunert, and T. F. Meyer. 1997. CD66 carcinoembryonic antigens mediate interactions between Opa-expressing *Neisseria gonorrhoeae* and human polymorphonuclear phagocytes. *EMBO J.* **16**:3435–3445.
109. Gray-Owen, S. D., D. R. Lorenzen, A. Haude, T. F. Meyer, and C. Dehio. 1997. Differential Opa specificities for CD66 receptors influence tissue interactions and cellular response to *Neisseria gonorrhoeae*. *Mol. Microbiol.* **26**:971–980.
110. Grundy, F. J., and M. M. Howe. 1984. Involvement of the invertible G segment in bacteriophage mu tail fiber biosynthesis. *Virology* **134**:296–317.
111. Guerry, P., C. M. Szymanski, M. M. Prendergast, T. E. Hickey, C. P. Ewing, D. L. Pattarini, and A. P. Moran. 2002. Phase variation of *Campylobacter jejuni* 81–176 lipooligosaccharide affects ganglioside mimicry and invasiveness in vitro. *Infect. Immun.* **70**:787–793.
112. Gumulak-Smith, J., A. Teachman, A. H. Tu, J. W. Simecka, J. R. Lindsey, and K. Dybvig. 2001. Variations in the surface proteins and restriction enzyme systems of *Mycoplasma pulmonis* in the respiratory tract of infected rats. *Mol. Microbiol.* **40**:1037–1044.
113. Gunther, N. W., IV, J. A. Snyder, V. Lockett, I. Blomfield, D. E. Johnson, and H. L. Mobley. 2002. Assessment of virulence of uropathogenic *Esche-*

- richia coli* type 1 fimbrial mutants in which the invertible element is phase-locked on or off. *Infect. Immun.* **70**:3344–3354.
114. Gunther, N. W., IV, V. Lockett, D. E. Johnson, and H. L. Mobley. 2001. In vivo dynamics of type 1 fimbria regulation in uropathogenic *Escherichia coli* during experimental urinary tract infection. *Infect. Immun.* **69**:2838–2846.
 115. Gupta, S., and R. M. Anderson. 1999. Population structure of pathogens: the role of immune selection. *Parasitol. Today* **15**:497–501.
 116. Haagmans, W., and M. van der Woude. 2000. Phase variation of Ag43 in *Escherichia coli*: Dam-dependent methylation abrogates OxyR binding and OxyR-mediated repression of transcription. *Mol. Microbiol.* **35**:877–887.
 117. Hackstadt, T., M. G. Peacock, P. J. Hitchcock, and R. L. Cole. 1985. Lipopolysaccharide variation in *Coxiella burnetii*: intrastain heterogeneity in structure and antigenicity. *Infect. Immun.* **48**:359–365.
 118. Hagblom, P., E. Segal, E. Billyard, and M. So. 1985. Intragenic recombination leads to pilus antigenic variation in *Neisseria gonorrhoeae*. *Nature* **315**:156–158.
 119. Hallet, B. 2001. Playing Dr Jekyll and Mr Hyde: combined mechanisms of phase variation in bacteria. *Curr. Opin. Microbiol.* **4**:570–581.
 120. Hallet, B., and D. J. Sherratt. 1997. Transposition and site-specific recombination: adapting DNA cut-and-paste mechanisms to a variety of genetic rearrangements. *FEMS Microbiol. Rev.* **21**:157–178.
 121. Hammerschmidt, S., R. Hilde, J. P. van Putten, R. Gerardy-Schahn, A. Unkmeier, and M. Frosch. 1996. Modulation of cell surface sialic acid expression in *Neisseria meningitidis* via a transposable genetic element. *EMBO J.* **15**:192–198.
 122. Hammerschmidt, S., A. Muller, H. Sillmann, M. Muhlenhoff, R. Borrow, A. Fox, J. van Putten, W. D. Zollinger, R. Gerardy-Schahn, and M. Frosch. 1996. Capsule phase variation in *Neisseria meningitidis* serogroup B by slipped-strand mispairing in the polysialyltransferase gene (*siaD*): correlation with bacterial invasion and the outbreak of meningococcal disease. *Mol. Microbiol.* **20**:1211–1220.
 123. Harrison, O. B., B. D. Robertson, S. N. Faust, M. A. Jepson, R. D. Goldin, M. Levin, and R. S. Heyderman. 2002. Analysis of pathogen-host cell interactions in purpura fulminans: expression of capsule, type IV pili, and PorA by *Neisseria meningitidis* in vivo. *Infect. Immun.* **70**:5193–5201.
 124. Heath, D. G., F. Y. An, K. E. Weaver, and D. B. Clewell. 1995. Phase variation of *Enterococcus faecalis* pAD1 conjugation functions relates to changes in iteron sequence region. *J. Bacteriol.* **177**:5453–5459.
 125. Heichman, K. A., and R. C. Johnson. 1990. The Hin invertasome: protein-mediated joining of distant recombination sites at the enhancer. *Science* **249**:511–517.
 126. Henderson, I. R., M. Meehan, and P. Owen. 1997. A novel regulatory mechanism for a novel phase-variable outer membrane protein of *Escherichia coli*. *Adv. Exp. Med. Biol.* **412**:349–355.
 127. Henderson, I. R., P. Owen, and J. P. Nataro. 1999. Molecular switches—the ON and OFF of bacterial phase variation. *Mol. Microbiol.* **33**:919–932.
 128. Hernday, A., M. Krabbe, B. Braaten, and D. Low. 2002. Self-perpetuating epigenetic pili switches in bacteria. *Proc. Natl. Acad. Sci. USA* **99**(Suppl. 4): 16470–16476.
 129. Hernday, A. D., B. A. Braaten, and D. A. Low. 2003. The mechanism by which DNA adenine methylase and PapI activate the *pap* epigenetic switch. *Mol. Cell.* **12**:947–957.
 130. Higgins, C. F., C. J. Dorman, D. A. Stirling, L. Waddell, I. R. Booth, G. May, and E. Bremer. 1988. A physiological role for DNA supercoiling in the osmotic regulation of gene expression in *S. typhimurium* and *E. coli*. *Cell* **52**: 569–584.
 131. High, N. J., M. E. Deadman, and E. R. Moxon. 1993. The role of a repetitive DNA motif (5'-CAAT-3') in the variable expression of the *Haemophilus influenzae* lipopolysaccharide epitope alpha Gal(1-4)beta Gal. *Mol. Microbiol.* **9**:1275–1282.
 132. High, N. J., M. P. Jennings, and E. R. Moxon. 1996. Tandem repeats of the tetramer 5'-CAAT-3' present in *lic2A* are required for phase variation but not lipopolysaccharide biosynthesis in *Haemophilus influenzae*. *Mol. Microbiol.* **20**:165–174.
 133. Hoffmaster, A. R., C. C. Fitzgerald, E. Ribot, L. W. Mayer, and T. Popovic. 2002. Molecular subtyping of *Bacillus anthracis* and the 2001 bioterrorism-associated anthrax outbreak, United States. *Emerg. Infect. Dis.* **8**:1111–1116.
 134. Holden, N. J., B. E. Uhlin, and D. L. Gally. 2001. PapB paralogues and their effect on the phase variation of type 1 fimbriae in *Escherichia coli*. *Mol. Microbiol.* **42**:319–330.
 135. Honarvar, S., B. K. Choi, and D. M. Schifferli. 2003. Phase variation of the 987P-like CS18 fimbriae of human enterotoxigenic *Escherichia coli* is regulated by site-specific recombinases. *Mol. Microbiol.* **48**:157–171.
 136. Hood, D. W., A. D. Cox, M. Gilbert, K. Makepeace, S. Walsh, M. E. Deadman, A. Cody, A. Martin, M. Mansson, E. K. Schweda, J. R. Brisson, J. C. Richards, E. R. Moxon, and W. W. Wakarchuk. 2001. Identification of a lipopolysaccharide alpha-2,3-sialyltransferase from *Haemophilus influenzae*. *Mol. Microbiol.* **39**:341–350.
 137. Hood, D. W., M. E. Deadman, M. P. Jennings, M. Bisercic, R. D. Fleischmann, J. C. Venter, and E. R. Moxon. 1996. DNA repeats identify novel virulence genes in *Haemophilus influenzae*. *Proc. Natl. Acad. Sci. USA* **93**: 11121–11125.
 138. Horino, A., Y. Sasaki, T. Sasaki, and T. Kenri. 2003. Multiple promoter inversions generate surface antigenic variation in *Mycoplasma penetrans*. *J. Bacteriol.* **185**:231–242.
 139. Hormaeche, C. E., P. Mastroeni, J. A. Harrison, R. Demarco de Hormaeche, S. Svenson, and B. A. Stocker. 1996. Protection against oral challenge three months after i.v. immunization of BALB/c mice with live Aro *Salmonella typhimurium* and *Salmonella enteritidis* vaccines is serotype (species)-dependent and only partially determined by the main LPS O antigen. *Vaccine* **14**:251–259.
 140. Hornef, M. W., M. J. Wick, M. Rhen, and S. Normark. 2002. Bacterial strategies for overcoming host innate and adaptive immune responses. *Nat. Immunol.* **3**:1033–1040.
 141. Hosking, S. L., J. E. Craig, and N. J. High. 1999. Phase variation of *lic1A*, *lic2A* and *lic3A* in colonization of the nasopharynx, bloodstream and cerebrospinal fluid by *Haemophilus influenzae* type b. *Microbiology* **145**:3005–3011.
 142. Howell-Adams, B., and H. S. Seifert. 2000. Molecular models accounting for the gene conversion reactions mediating gonococcal pilin antigenic variation. *Mol. Microbiol.* **37**:1146–1158.
 143. Howell-Adams, B., L. A. Wainwright, and H. S. Seifert. 1996. The size and position of heterologous insertions in a silent locus differentially affect pilin recombination in *Neisseria gonorrhoeae*. *Mol. Microbiol.* **22**:509–522.
 144. Hull, R. A., R. E. Gill, P. Hsu, B. H. Minschew, and S. Falkow. 1981. Construction and expression of recombinant plasmids encoding type 1 or D-mannose-resistant pili from a urinary tract infection *Escherichia coli* isolate. *Infect. Immun.* **33**:933–938.
 145. Hultgren, S. J., T. N. Porter, A. J. Schaeffer, and J. L. Duncan. 1985. Role of type 1 pili and effects of phase variation on lower urinary tract infections produced by *Escherichia coli*. *Infect. Immun.* **50**:370–377.
 146. Humphries, A. D., M. Raffatelli, S. Winter, E. H. Weening, R. A. Kingsley, R. Droleskey, S. Zhang, J. Figueiredo, S. Khare, J. Nunes, L. G. Adams, R. M. Tsois, and A. J. Baumler. 2003. The use of flow cytometry to detect expression of subunits encoded by 11 *Salmonella enterica* serotype Typhimurium fimbrial operons. *Mol. Microbiol.* **48**:1357–1376.
 147. Humphries, A. D., S. M. Townsend, R. A. Kingsley, T. L. Nicholson, R. M. Tsois, and A. J. Baumler. 2001. Role of fimbriae as antigens and intestinal colonization factors of *Salmonella* serovars. *FEMS Microbiol. Lett.* **201**: 121–125.
 148. Hung, D. L., T. L. Raivio, C. H. Jones, T. J. Silhavy, and S. J. Hultgren. 2001. Cpx signaling pathway monitors biogenesis and affects assembly and expression of P pili. *EMBO J.* **20**:1508–1518.
 149. Iino, T., and K. Kutsukake. 1981. Trans-acting genes of bacteriophages P1 and Mu mediate inversion of a specific DNA segment involved in flagellar phase variation of *Salmonella*. *Cold Spring Harbor Symp. Quant. Biol.* **45**: 11–16.
 150. Ikeda, J. S., C. K. Schmitt, S. C. Darnell, P. R. Watson, J. Bispham, T. S. Wallis, D. L. Weinstein, E. S. Metcalf, P. Adams, C. D. O'Connor, and A. D. O'Brien. 2001. Flagellar phase variation of *Salmonella enterica* serovar Typhimurium contributes to virulence in the murine typhoid infection model but does not influence *Salmonella*-induced enteropathogenesis. *Infect. Immun.* **69**:3021–3030.
 151. Inzana, T. J., R. P. Gogolewski, and L. B. Corbeil. 1992. Phenotypic phase variation in *Haemophilus somnus* lipooligosaccharide during bovine pneumonia and after in vitro passage. *Infect. Immun.* **60**:2943–2951.
 152. Inzana, T. J., J. Hensley, J. McQuiston, A. J. Lesse, A. A. Campagnari, S. M. Boyle, and M. A. Apicella. 1997. Phase variation and conservation of lipooligosaccharide epitopes in *Haemophilus somnus*. *Infect. Immun.* **65**: 4675–4681.
 153. Isaacson, R. E., C. Argyilan, L. Kwan, S. Patterson, and K. Yoshinaga. 1999. Phase variable switching of in vivo and environmental phenotypes of *Salmonella typhimurium*. *Adv. Exp. Med. Biol.* **473**:281–289.
 154. Ishiwa, A., and T. Komano. 2000. The lipopolysaccharide of recipient cells is a specific receptor for PilV proteins, selected by shufflon DNA rearrangement, in liquid matings with donors bearing the R64 plasmid. *Mol. Gen. Genet.* **263**:159–164.
 155. Jarosik, G. P., and E. J. Hansen. 1994. Identification of a new locus involved in expression of *Haemophilus influenzae* type b lipooligosaccharide. *Infect. Immun.* **62**:4861–4867.
 156. Jennings, M. P., D. W. Hood, I. R. Peak, M. Virji, and E. R. Moxon. 1995. Molecular analysis of a locus for the biosynthesis and phase-variable expression of the lacto-N-neotetraose terminal lipopolysaccharide structure in *Neisseria meningitidis*. *Mol. Microbiol.* **18**:729–740.
 157. Jennings, M. P., Y. N. Srihanta, E. R. Moxon, M. Kramer, J. T. Poolman, B. Kuipers, and P. van der Ley. 1999. The genetic basis of the phase variation repertoire of lipopolysaccharide immunotypes in *Neisseria meningitidis*. *Microbiology* **145**:3013–3021.
 158. Jennings, M. P., M. Virji, D. Evans, V. Foster, Y. N. Srihanta, L. Steeghs, P. van der Ley, and E. R. Moxon. 1998. Identification of a novel gene involved in pilin glycosylation in *Neisseria meningitidis*. *Mol. Microbiol.* **29**: 975–984.

159. Jerse, A. E., M. S. Cohen, P. M. Drown, L. G. Whicker, S. F. Isbey, H. S. Seifert, and J. G. Cannon. 1994. Multiple gonococcal opacity proteins are expressed during experimental urethral infection in the male. *J. Exp. Med.* **179**:911–920.
160. Johnson, R. C. 2002. Bacterial site-specific DNA inversion systems, p. 230–271. In N. L. Craig, R. Craigie, M. Gellert, and A. M. Lambowitz (ed.), *Mobile DNA II*. ASM Press, Washington, D.C.
161. Johnson, R. C., M. F. Bruist, and M. I. Simon. 1986. Host protein requirements for in vitro site-specific DNA inversion. *Cell* **46**:531–539.
162. Jones, D. M., R. Borrow, A. J. Fox, S. Gray, K. A. Cartwright, and J. T. Poolman. 1992. The lipooligosaccharide immunotype as a virulence determinant in *Neisseria meningitidis*. *Microb. Pathog.* **13**:219–224.
163. Jones, G. W., D. B. Clewell, L. G. Charles, and M. M. Vickerman. 1996. Multiple phase variation in haemolytic, adhesive and antigenic properties of *Streptococcus gordonii*. *Microbiology* **142**:181–189.
164. Jonsson, A. B., G. Nyberg, and S. Normark. 1991. Phase variation of gonococcal pili by frameshift mutation in *pilC*, a novel gene for pilus assembly. *EMBO J.* **10**:477–488.
165. Josenhans, C., K. A. Eaton, T. Thevenot, and S. Suerbaum. 2000. Switching of flagellar motility in *Helicobacter pylori* by reversible length variation of a short homopolymeric sequence repeat in *flpP*, a gene encoding a basal body protein. *Infect. Immun.* **68**:4598–4603.
166. Joyce, S. A., and C. J. Dorman. 2002. A Rho-dependent phase-variable transcription terminator controls expression of the FimE recombinase in *Escherichia coli*. *Mol. Microbiol.* **45**:1107–1117.
167. Kahler, C. M., and D. S. Stephens. 1998. Genetic basis for biosynthesis, structure, and function of meningococcal lipooligosaccharide (endotoxin). *Crit. Rev. Microbiol.* **24**:281–334.
168. Kaltenbach, L. S., B. A. Braaten, and D. A. Low. 1995. Specific binding of PapI to Lrp-Pap DNA complexes. *J. Bacteriol.* **177**:6449–6455.
169. Karlyshev, A. V., D. Linton, N. A. Gregson, and B. W. Wren. 2002. A novel paralogous gene family involved in phase-variable flagella-mediated motility in *Campylobacter jejuni*. *Microbiology* **148**:473–480.
170. Kawula, T. H., E. L. Aho, D. S. Barritt, D. G. Klapper, and J. G. Cannon. 1988. Reversible phase variation of expression of *Neisseria meningitidis* class 5 outer membrane proteins and their relationship to gonococcal proteins II. *Infect. Immun.* **56**:380–386.
171. Kenri, T., R. Taniguchi, Y. Sasaki, N. Okazaki, M. Narita, K. Izumikawa, M. Umetsu, and T. Sasaki. 1999. Identification of a new variable sequence in the P1 cytoadhesin gene of *Mycoplasma pneumoniae*: evidence for the generation of antigenic variation by DNA recombination between repetitive sequences. *Infect. Immun.* **67**:4557–4562.
172. Kim, J. O., and J. N. Weiser. 1998. Association of intrastrain phase variation in quantity of capsular polysaccharide and teichoic acid with the virulence of *Streptococcus pneumoniae*. *J. Infect. Dis.* **177**:368–377.
173. Kingsley, R. A., and A. J. Bäumlér. 2000. Host adaptation and the emergence of infectious disease: the salmonella paradigm. *Mol. Microbiol.* **36**:1006–1014.
174. Klemm, P. 1986. Two regulatory *fim* genes, *fimB* and *fimE*, control the phase variation of type 1 fimbriae in *Escherichia coli*. *EMBO J.* **5**:1389–1393.
175. Klevytska, A. M., L. B. Price, J. M. Schupp, P. L. Worsham, J. Wong, and P. Keim. 2001. Identification and characterization of variable-number tandem repeats in the *Yersinia pestis* genome. *J. Clin. Microbiol.* **39**:3179–3185.
176. Kline, K. A., E. V. Sechman, E. P. Skaar, and H. S. Seifert. 2003. Recombination, repair and replication in the pathogenic neisseriae: the 3 R's of molecular genetics of two human-specific bacterial pathogens. *Mol. Microbiol.* **50**:3–13.
177. Komano, T. 1999. Shufflons: multiple inversion systems and integrons. *Annu. Rev. Genet.* **33**:171–191.
178. Komano, T., S. R. Kim, T. Yoshida, and T. Nisioka. 1994. DNA rearrangement of the shufflon determines recipient specificity in liquid mating of IncII plasmid R64. *J. Mol. Biol.* **243**:6–9.
179. Kooistra, O., E. Luneberg, Y. A. Knirel, M. Frosch, and U. Zahringer. 2002. N-Methylation in poly(γ-glutamic acid) is associated with the phase-variable epitope of *Legionella pneumophila* serogroup 1 lipopolysaccharide. Identification of 5-(N,N-dimethylacetimidoyl)amino and 5-acetimidoyl(N-methyl)amino-7-acetamido-3,5,7,9-tetraoxynon-2-ulonic acid in the O-chain polysaccharide. *Eur. J. Biochem.* **269**:560–572.
180. Koomey, J. M. 1994. Mechanisms of pilus antigenic variation in *Neisseria gonorrhoeae*, p. 113–126. In V. I. Miller, J. B. Kaper, D. A. Portnoy, and R. R. Isberg (ed.), *Molecular genetics of bacterial pathogenesis*. ASM Press, Washington, D.C.
181. Koomey, M. 1997. Bacterial pathogenesis: a variation on variation in Lyme disease. *Curr. Biol.* **7**:R538–R540.
182. Koomey, M., E. C. Gotschlich, K. Robbins, S. Bergstrom, and J. Swanson. 1987. Effects of *recA* mutations on pilus antigenic variation and phase transitions in *Neisseria gonorrhoeae*. *Genetics* **117**:391–398.
183. Krabbe, M., N. Weyand, and D. Low. 2000. Environmental control of pilus gene expression, p. 305–321. In G. Storz and R. Hengge-Aronis (ed.), *Bacterial stress responses*. ASM Press, Washington, D.C.
- 183a. Krinos, C. M., M. J. Coyne, K. G. Weinacht, A. O. Tzianabos, D. L. Kasper, and L. E. Comstock. 2001. Extensive surface diversity of a commensal microorganism by multiple DNA inversions. *Nature* **414**:555–558.
184. Kroll, J. S., I. Hopkins, and E. R. Moxon. 1988. Capsule loss in *H. influenzae* type b occurs by recombination-mediated disruption of a gene essential for polysaccharide export. *Cell* **53**:347–356.
185. Kroll, J. S., B. Loynds, L. N. Brophy, and E. R. Moxon. 1990. The *bex* locus in encapsulated *Haemophilus influenzae*: a chromosomal region involved in capsule polysaccharide export. *Mol. Microbiol.* **4**:1853–1862.
186. Kroll, J. S., B. M. Loynds, and E. R. Moxon. 1991. The *Haemophilus influenzae* capsulation gene cluster: a compound transposon. *Mol. Microbiol.* **5**:1549–1560.
187. Kulasekara, H. D., and I. C. Blomfield. 1999. The molecular basis for the specificity of *fimE* in the phase variation of type 1 fimbriae of *Escherichia coli* K-12. *Mol. Microbiol.* **31**:1171–1181.
188. Kwan, L. Y., and R. E. Isaacson. 1998. Identification and characterization of a phase-variable nonfimbrial *Salmonella typhimurium* gene that alters O-antigen production. *Infect. Immun.* **66**:5725–5730.
189. Labandeira-Rey, M., J. Seshu, and J. T. Skare. 2003. The absence of linear plasmid 25 or 28–1 of *Borrelia burgdorferi* dramatically alters the kinetics of experimental infection via distinct mechanisms. *Infect. Immun.* **71**:4608–4613.
190. Ladefoged, S. A. 2000. Molecular dissection of *Mycoplasma hominis*. *APMIS Suppl.* **97**:1–45.
191. Lafontaine, E. R., N. J. Wagner, and E. J. Hansen. 2001. Expression of the *Moraxella catarrhalis* UspA1 protein undergoes phase variation and is regulated at the transcriptional level. *J. Bacteriol.* **183**:1540–1551.
192. Laity, C., K. F. Chater, C. G. Lewis, and M. J. Buttner. 1993. Genetic analysis of the phi C31-specific phage growth limitation (Pgl) system of *Streptomyces coelicolor* A3(2). *Mol. Microbiol.* **7**:329–336.
193. Langermann, S., and W. R. Ballou, Jr. 2001. Vaccination utilizing the FimCH complex as a strategy to prevent *Escherichia coli* urinary tract infections. *J. Infect. Dis.* **183**(Suppl. 1):S84–S86.
194. Langermann, S., R. Mollby, J. E. Burlein, S. R. Palaszynski, C. G. Auguste, A. DeFusco, R. Strouse, M. A. Schenerman, S. J. Hultgren, J. S. Pinkner, J. Winberg, L. Guldevall, M. Soderhall, K. Ishikawa, S. Normark, and S. Koenig. 2000. Vaccination with FimH adhesin protects cynomolgus monkeys from colonization and infection by uropathogenic *Escherichia coli*. *J. Infect. Dis.* **181**:774–778.
195. La Penta, D., X. P. Zhang, and P. P. Cleary. 1994. *Streptococcus pyogenes* type IIa IgG Fc receptor expression is co-ordinately regulated with M protein and streptococcal C5a peptidase. *Mol. Microbiol.* **12**:873–879.
196. Lavitola, A., C. Bucci, P. Salvatore, G. Maresca, C. B. Bruni, and P. Alifano. 1999. Intracistronic transcription termination in polysialyltransferase gene (*siaD*) affects phase variation in *Neisseria meningitidis*. *Mol. Microbiol.* **33**:119–127.
197. Lenich, A. G., and A. C. Glasgow. 1994. Amino acid sequence homology between Piv, an essential protein in site-specific DNA inversion in *Moraxella lacunata*, and transposases of an unusual family of insertion elements. *J. Bacteriol.* **176**:4160–4164.
198. Lerche, M. 1937. Die beim Tier vorkommenden Erkrankungen der Bakterien der Paratyphus-Enteritidis-Gruppe und ihre Epidemiologie. Sammelbericht III. Bericht über die 17. Tagung der Deutschen Vereinigung für Mikrobiologie vom 20. bis 22. September 1937 in Berlin. Zentbl. Bakteriologie. Parasitenkd. Infektionskr. Hyg. Abt. I Orig. **140**:39–52.
199. Lerouge, I., and J. Vanderleyden. 2002. O-antigen structural variation: mechanisms and possible roles in animal/plant-microbe interactions. *FEMS Microbiol. Rev.* **26**:17–47.
200. Levinson, G., and G. A. Gutman. 1987. Slipped-strand mispairing: a major mechanism for DNA sequence evolution. *Mol. Biol. Evol.* **4**:203–221.
201. Lewis, L. A., M. Gipson, K. Hartman, T. Ownbey, J. Vaughn, and D. W. Dyer. 1999. Phase variation of HpuAB and HmbR, two distinct haemoglobin receptors of *Neisseria meningitidis* DNM2. *Mol. Microbiol.* **32**:977–989.
202. Li, X., C. V. Lockatell, D. E. Johnson, and H. L. Mobley. 2002. Identification of MrpI as the sole recombinase that regulates the phase variation of MR/P fimbria, a bladder colonization factor of uropathogenic *Proteus mirabilis*. *Mol. Microbiol.* **45**:865–874.
203. Li, X., D. A. Rasko, C. V. Lockatell, D. E. Johnson, and H. L. Mobley. 2001. Repression of bacterial motility by a novel fimbrial gene product. *EMBO J.* **20**:4854–4862.
204. Liaudet, L., A. Deb, P. Pacher, J. G. Mabley, K. G. Murthy, A. L. Salzman, and C. Szabo. 2002. The flagellin-TLR5 axis: therapeutic opportunities. *Drug News Perspect.* **15**:397–409.
205. Lim, J. K., N. W. t. Gunther, H. Zhao, D. E. Johnson, S. K. Keay, and H. L. Mobley. 1998. In vivo phase variation of *Escherichia coli* type 1 fimbrial genes in women with urinary tract infection. *Infect. Immun.* **66**:3303–3310.
206. Linton, D., M. Gilbert, P. G. Hitchen, A. Dell, H. R. Morris, W. W. Wakarchuk, N. A. Gregson, and B. W. Wren. 2000. Phase variation of a beta-1,3-galactosyltransferase involved in generation of the ganglioside GM1-like lipo-oligosaccharide of *Campylobacter jejuni*. *Mol. Microbiol.* **37**:501–514.
207. Liu, L., K. Dybvig, V. S. Panangala, V. L. van Santen, and C. T. French. 2000. GAA trinucleotide repeat region regulates M9/pMGA gene expression in *Mycoplasma gallisepticum*. *Infect. Immun.* **68**:871–876.

208. Loessner, I., K. Dietrich, D. Dittrich, J. Hacker, and W. Ziebuhr. 2002. Transposase-dependent formation of circular IS256 derivatives in *Staphylococcus epidermidis* and *Staphylococcus aureus*. *J. Bacteriol.* **184**:4709–4714.
209. Low, D., B. A. Braaten, and M. van der Woude. 1996. Fimbriae, p. 146–157. In F. C. Neidhardt, R. Curtiss III, J. L. Ingraham, E. C. C. Lin, K. B. Low, B. Magasanik, W. S. Reznikoff, M. Riley, M. Schaechter, and H. E. Umbarger (ed.), *Escherichia coli* and *Salmonella*: cellular and molecular biology, 2nd ed. ASM Press, Washington, D.C.
210. Low, D. A., N. J. Weyand, and M. J. Mahan. 2001. Roles of DNA adenine methylation in regulating bacterial gene expression and virulence. *Infect. Immun.* **69**:7197–7204.
211. Lukacova, M., M. Baumann, L. Brade, U. Mamat, and H. Brade. 1994. Lipopolysaccharide smooth-rough phase variation in bacteria of the genus *Chlamydia*. *Infect. Immun.* **62**:2270–2276.
212. Luneberg, E., B. Mayer, N. Daryab, O. Kooistra, U. Zahringer, M. Rohde, J. Swanson, and M. Frosch. 2001. Chromosomal insertion and excision of a 30 kb unstable genetic element is responsible for phase variation of lipopolysaccharide and other virulence determinants in *Legionella pneumophila*. *Mol. Microbiol.* **39**:1259–1271.
213. Luneberg, E., U. Zahringer, Y. A. Knirel, D. Steinmann, M. Hartmann, I. Steinmetz, M. Rohde, J. Kohl, and M. Frosch. 1998. Phase-variable expression of lipopolysaccharide contributes to the virulence of *Legionella pneumophila*. *J. Exp. Med.* **188**:49–60.
214. Lysenko, E., J. C. Richards, A. D. Cox, A. Stewart, A. Martin, M. Kapoor, and J. N. Weiser. 2000. The position of phosphorylcholine on the lipopolysaccharide of *Haemophilus influenzae* affects binding and sensitivity to C-reactive protein-mediated killing. *Mol. Microbiol.* **35**:234–245.
215. Lysnyansky, I., Y. Ron, and D. Yogeve. 2001. Juxtaposition of an active promoter to vsp genes via site-specific DNA inversions generates antigenic variation in *Mycoplasma bovis*. *J. Bacteriol.* **183**:5698–5708.
216. Lysnyansky, I., R. Rosengarten, and D. Yogeve. 1996. Phenotypic switching of variable surface lipoproteins in *Mycoplasma bovis* involves high-frequency chromosomal rearrangements. *J. Bacteriol.* **178**:5395–5401.
217. Maizels, R. M., and A. Kurniawan-Atmadja. 2002. Variation and polymorphism in helminth parasites. *Parasitology* **125**(Suppl):S25–S37.
218. Mandrell, R. E., and M. A. Apicella. 1993. Lipo-oligosaccharides (LOS) of mucosal pathogens: molecular mimicry and host-modification of LOS. *Immunobiology* **187**:382–402.
219. Mandrell, R. E., J. M. Griffiss, and B. A. Macher. 1988. Lipooligosaccharides (LOS) of *Neisseria gonorrhoeae* and *Neisseria meningitidis* have components that are immunohemically similar to precursors of human blood group antigens. Carbohydrate sequence specificity of the mouse monoclonal antibodies that recognize crossreacting antigens on LOS and human erythrocytes. *J. Exp. Med.* **168**:107–126.
220. Mandrell, R. E., and W. D. Zollinger. 1977. Lipopolysaccharide serotyping of *Neisseria meningitidis* by hemagglutination inhibition. *Infect. Immun.* **16**:471–475.
221. Manning, P. A., A. Kaufmann, U. Roll, J. Pohlner, T. F. Meyer, and R. Haas. 1991. L-pilin variants of *Neisseria gonorrhoeae* MS11. *Mol. Microbiol.* **5**:917–926.
222. Marrs, C. F., F. W. Rozsa, M. Hackel, S. P. Stevens, and A. C. Glasgow. 1990. Identification, cloning, and sequencing of *piv*, a new gene involved in inverting the pilin genes of *Moraxella lacunata*. *J. Bacteriol.* **172**:4370–4377.
223. Marrs, C. F., W. W. Ruehl, G. K. Schoolnik, and S. Falkow. 1988. Pilin-gene phase variation of *Moraxella bovis* is caused by an inversion of the pilin genes. *J. Bacteriol.* **170**:3032–3039.
224. Martin, C. 1996. The *clp* (CS31A) operon is negatively controlled by Lrp, ClpB, and L-alanine at the transcriptional level. *Mol. Microbiol.* **21**:281–292.
225. Martin, P., T. van de Ven, N. Mouchel, A. C. Jeffries, D. W. Hood, and E. R. Moxon. 2003. Experimentally revised repertoire of putative contingency loci in *Neisseria meningitidis* strain MC58: evidence for a novel mechanism of phase variation. *Mol. Microbiol.* **50**:245–257.
226. Maskell, D. J., M. J. Szabo, P. D. Butler, A. E. Williams, and E. R. Moxon. 1991. Phase variation of lipopolysaccharide in *Haemophilus influenzae*. *Res. Microbiol.* **142**:719–724.
227. Mattick, J. S. 2002. Type IV pili and twitching motility. *Annu. Rev. Microbiol.* **56**:289–314.
228. Mattoo, S., A. K. Foreman-Wykert, P. A. Cotter, and J. F. Miller. 2001. Mechanisms of *Bordetella* pathogenesis. *Front. Biosci.* **6**:E168–E186.
229. McClain, M. S., I. C. Blomfield, K. J. Eberhardt, and B. I. Eisenstein. 1993. Inversion-independent phase variation of type 1 fimbriae in *Escherichia coli*. *J. Bacteriol.* **175**:4335–4344.
230. McClain, M. S., I. C. Blomfield, and B. I. Eisenstein. 1991. Roles of *fimB* and *fimE* in site-specific DNA inversion associated with phase variation of type 1 fimbriae in *Escherichia coli*. *J. Bacteriol.* **173**:5308–5314.
231. McClelland, M., K. E. Sanderson, J. Spieth, S. W. Clifton, P. Latreille, L. Courtney, S. Porwollik, J. Ali, M. Dante, F. Du, S. Hou, D. Layman, S. Leonard, C. Nguyen, K. Scott, A. Holmes, N. Grewal, E. Mulvaney, E. Ryan, H. Sun, L. Florea, W. Miller, T. Stoneking, M. Nhan, R. Waterston, and R. K. Wilson. 2001. Complete genome sequence of *Salmonella enterica* serovar Typhimurium LT2. *Nature* **413**:852–856.
232. McDowell, J. V., S. Y. Sung, L. T. Hu, and R. T. Marconi. 2002. Evidence that the variable regions of the central domain of VlsE are antigenic during infection with Lyme disease spirochetes. *Infect. Immun.* **70**:4196–4203.
233. McIver, K. S., A. S. Heath, B. D. Green, and J. R. Scott. 1995. Specific binding of the activator Mga to promoter sequences of the *emm* and *scpA* genes in the group A *Streptococcus*. *J. Bacteriol.* **177**:6619–6624.
234. McLandsborough, L. A., and P. P. Cleary. 1995. Insertional inactivation of *virR* in *Streptococcus pyogenes* M49 demonstrates that VirR functions as a positive regulator of ScpA, FcRA, OF, and M protein. *FEMS Microbiol. Lett.* **128**:45–51.
235. McLandsborough, L. A., and P. P. Cleary. 1995. Insertional inactivation of *virR* in *Streptococcus pyogenes* M49 demonstrates that VirR functions as a positive regulator of streptococcal C5a peptidase and M protein in OF⁺ strains. *Dev. Biol. Stand.* **85**:149–152.
236. McNeil, G., and M. Virji. 1997. Phenotypic variants of meningococci and their potential in phagocytic interactions: the influence of opacity proteins, pili, PilC and surface sialic acids. *Microb. Pathog.* **22**:295–304.
237. Mehr, I. J., and H. S. Seifert. 1998. Differential roles of homologous recombination pathways in *Neisseria gonorrhoeae* pilin antigenic variation, DNA transformation and DNA repair. *Mol. Microbiol.* **30**:697–710.
238. Meier, J. T., M. I. Simon, and A. G. Barbour. 1985. Antigenic variation is associated with DNA rearrangements in a relapsing fever *Borrelia*. *Cell* **41**:403–409.
239. Merickek, S. K., M. J. Haykinson, and R. C. Johnson. 1998. Communication between Hin recombinase and Fis regulatory subunits during coordinate activation of Hin-catalyzed site-specific DNA inversion. *Genes Dev.* **12**:2803–2816.
240. Meyer, T. F., and J. P. van Putten. 1989. Genetic mechanisms and biological implications of phase variation in pathogenic neisseriae. *Clin. Microbiol. Rev.* **2**(Suppl):S139–S145.
241. Moran, A. P., Y. A. Knirel, S. N. Senchenkova, G. Widmalm, S. O. Hynes, and P. E. Jansson. 2002. Phenotypic variation in molecular mimicry between *Helicobacter pylori* lipopolysaccharides and human gastric epithelial cell surface glycoforms. Acid induced phase variation in Lewis(x) and Lewis(y) expression by *H. pylori* lipopolysaccharides. *J. Biol. Chem.* **277**:5785–5795.
242. Moran, E. E., B. L. Brandt, and W. D. Zollinger. 1994. Expression of the L8 lipopolysaccharide determinant increases the sensitivity of *Neisseria meningitidis* to serum bactericidal activity. *Infect. Immun.* **62**:5290–5295.
243. Morris, C., C. M. Yip, I. S. Tsui, D. K. Wong, and J. Hackett. 2003. The shufflon of *Salmonella enterica* serovar Typhi regulates type IVB pilus-mediated bacterial self-association. *Infect. Immun.* **71**:1141–1146.
244. Moxon, E. R., B. E. Gewurz, J. C. Richards, T. Inzana, M. P. Jennings, and D. W. Hood. 1996. Phenotypic switching of *Haemophilus influenzae*. *Mol. Microbiol.* **19**:1149–1150.
245. Moxon, E. R., P. B. Rainey, M. A. Nowak, and R. E. Lenski. 1994. Adaptive evolution of highly mutable loci in pathogenic bacteria. *Curr. Biol.* **4**:24–33.
246. Murphy, G. L., T. D. Connell, D. S. Barritt, M. Koomey, and J. G. Cannon. 1989. Phase variation of gonococcal protein II: regulation of gene expression by slipped-strand mispairing of a repetitive DNA sequence. *Cell* **56**:539–547.
247. Nassif, X., J. Lowy, P. Stenberg, P. O'Gaora, A. Ganji, and M. So. 1993. Antigenic variation of pilin regulates adhesion of *Neisseria meningitidis* to human epithelial cells. *Mol. Microbiol.* **8**:719–725.
248. Nassif, X., M. Marceau, C. Pujol, B. Pron, J. L. Beretti, and M. K. Taha. 1997. Type 4 pili and meningococcal adhesiveness. *Gene* **192**:149–153.
249. Nassif, X., C. Pujol, P. Morand, and E. Eugene. 1999. Interactions of pathogenic *Neisseria* with host cells. Is it possible to assemble the puzzle? *Mol. Microbiol.* **32**:1124–1132.
250. Neyrolles, O., I. Chambaud, S. Ferris, M. C. Prevost, T. Sasaki, L. Montagnier, and A. Blanchard. 1999. Phase variations of the *Mycoplasma penetrans* main surface lipoprotein increase antigenic diversity. *Infect. Immun.* **67**:1569–1578.
251. Nicholson, B., and D. Low. 2000. DNA methylation-dependent regulation of *pef* expression in *Salmonella typhimurium*. *Mol. Microbiol.* **35**:728–742.
252. Nicholson, T. L., and A. J. Baumber. 2001. *Salmonella enterica* serotype Typhimurium elicits cross-immunity against a *Salmonella enterica* serotype Enteritidis strain expressing LP fimbriae from the *lac* promoter. *Infect. Immun.* **69**:204–212.
253. Noormohammadi, A. H., P. F. Markham, M. F. Duffy, K. G. Whithear, and G. F. Browning. 1998. Multigene families encoding the major hemagglutinins in phylogenetically distinct mycoplasmas. *Infect. Immun.* **66**:3470–3475.
254. Noormohammadi, A. H., P. F. Markham, A. Kanci, K. G. Whithear, and G. F. Browning. 2000. A novel mechanism for control of antigenic variation in the haemagglutinin gene family of *Mycoplasma synoviae*. *Mol. Microbiol.* **35**:911–923.
255. Norris, T. L., and A. J. Baumber. 1999. Phase variation of the *lpf* operon is a mechanism to evade cross-immunity between *Salmonella* serotypes. *Proc. Natl. Acad. Sci. USA* **96**:13393–13398.
256. Norris, T. L., R. A. Kingsley, and A. J. Bumler. 1998. Expression and

- transcriptional control of the *Salmonella typhimurium* lpf fimbrial operon by phase variation. *Mol. Microbiol.* **29**:311–320.
257. **Nou, X., B. Braaten, L. Kaltenbach, and D. A. Low.** 1995. Differential binding of Lrp to two sets of *pap* DNA binding sites mediated by Pap I regulates Pap phase variation in *Escherichia coli*. *EMBO J.* **14**:5785–5797.
258. **Nou, X., B. Skinner, B. Braaten, L. Blyn, D. Hirsch, and D. Low.** 1993. Regulation of pyelonephritis-associated pili phase-variation in *Escherichia coli*: binding of the PapI and the Lrp regulatory proteins is controlled by DNA methylation. *Mol. Microbiol.* **7**:545–553.
259. **Nowicki, B., M. Rhen, V. Vaisanen-Rhen, A. Pere, and T. K. Korhonen.** 1984. Immunofluorescence study of fimbrial phase variation in *Escherichia coli* KS71. *J. Bacteriol.* **160**:691–695.
260. **O'Gara J. P., and C. J. Dorman.** 2000. Effects of local transcription and H-NS on inversion of the *fim* switch of *Escherichia coli*. *Mol. Microbiol.* **36**:457–466.
261. **Olsen, P. B., and P. Klemm.** 1994. Localization of promoters in the *fim* gene cluster and the effect of H-NS on the transcription of *fimB* and *fimE*. *FEMS Microbiol. Lett.* **116**:95–100.
262. **Olsen, P. B., M. A. Schembri, D. L. Gally, and P. Klemm.** 1998. Differential temperature modulation by H-NS of the *fimB* and *fimE* recombinase genes which control the orientation of the type 1 fimbrial phase switch. *FEMS Microbiol. Lett.* **162**:17–23.
263. **O'Toole, G., H. B. Kaplan, and R. Kolter.** 2000. Biofilm formation as microbial development. *Annu. Rev. Microbiol.* **54**:49–79.
264. **Ottemann, K. M., and A. C. Lowenthal.** 2002. *Helicobacter pylori* uses motility for initial colonization and to attain robust infection. *Infect. Immun.* **70**:1984–1990.
265. **Ottemann, K. M., and J. F. Miller.** 1997. Roles for motility in bacterial-host interactions. *Mol. Microbiol.* **24**:1109–1117.
266. **Otto, K., and T. J. Silhavy.** 2002. Surface sensing and adhesion of *Escherichia coli* controlled by the Cpx-signaling pathway. *Proc. Natl. Acad. Sci. USA* **99**:2287–2292.
267. **Ou, J. T., L. S. Baron, F. A. Rubin, and D. J. Kopecko.** 1988. Specific insertion and deletion of insertion sequence 1-like DNA element causes the reversible expression of the virulence capsular antigen Vi of *Citrobacter freundii* in *Escherichia coli*. *Proc. Natl. Acad. Sci. USA* **85**:4402–4405.
268. **Overweg, K., C. D. Pericone, G. G. Verhoef, J. N. Weiser, H. D. Meiring, A. P. De Jong, R. De Groot, and P. W. Hermans.** 2000. Differential protein expression in phenotypic variants of *Streptococcus pneumoniae*. *Infect. Immun.* **68**:4604–4610.
269. **Owen, P., P. Caffrey, and L.-G. Josefsson.** 1987. Identification and partial characterization of a novel bipartite protein antigen associated with the outer membrane of *Escherichia coli*. *J. Bacteriol.* **169**:3770–3777.
270. **Owen, P., M. Meehan, H. de Loughry-Doherty, and I. Henderson.** 1996. Phase-variable outer membrane proteins in *Escherichia coli*. *FEMS Immunol. Med. Microbiol.* **16**:63–76.
271. **Parge, H. E., K. T. Forest, M. J. Hickey, D. A. Christensen, E. D. Getzoff, and J. A. Tainer.** 1995. Structure of the fibre-forming protein pili at 2.6 Å resolution. *Nature* **378**:32–38.
272. **Park, S. F., D. Purdy, and S. Leach.** 2000. Localized reversible frameshift mutation in the *flhA* gene confers phase variability to flagellin gene expression in *Campylobacter coli*. *J. Bacteriol.* **182**:207–210.
273. **Parkhill, J., M. Achtman, K. D. James, S. D. Bentley, C. Churcher, S. R. Klee, G. Morelli, D. Basham, D. Brown, T. Chillingworth, R. M. Davies, P. Davis, K. Devlin, T. Feltham, N. Hamlin, S. Holroyd, K. Jagels, S. Leather, S. Moule, K. Mungall, M. A. Quail, M. A. Rajandream, K. M. Rutherford, M. Simmonds, J. Skelton, S. Whitehead, B. G. Spratt, and B. G. Barrell.** 2000. Complete DNA sequence of a serogroup A strain of *Neisseria meningitidis* Z2491. *Nature* **404**:502–506.
274. **Parkhill, J., B. W. Wren, K. Mungall, J. M. Ketley, C. Churcher, D. Basham, T. Chillingworth, R. M. Davies, T. Feltham, S. Holroyd, K. Jagels, A. V. Karlyshev, S. Moule, M. J. Pallen, C. W. Penn, M. A. Quail, M. A. Rajandream, K. M. Rutherford, A. H. van Vliet, S. Whitehead, and B. G. Barrell.** 2000. The genome sequence of the food-borne pathogen *Campylobacter jejuni* reveals hypervariable sequences. *Nature* **403**:665–668.
275. **Pericone, C. D., D. Bae, M. Shchepetov, T. McCool, and J. N. Weiser.** 2002. Short-sequence tandem and nontandem DNA repeats and endogenous hydrogen peroxide production contribute to genetic instability of *Streptococcus pneumoniae*. *J. Bacteriol.* **184**:4392–4399.
276. **Pericone, C. D., K. Overweg, P. W. Hermans, and J. N. Weiser.** 2000. Inhibitory and bactericidal effects of hydrogen peroxide production by *Streptococcus pneumoniae* on other inhabitants of the upper respiratory tract. *Infect. Immun.* **68**:3990–3997.
277. **Perkins-Balding, D., G. Duval-Valentin, and A. C. Glasgow.** 1999. Excision of IS492 requires flanking target sequences and results in circle formation in *Pseudoalteromonas atlantica*. *J. Bacteriol.* **181**:4937–4948.
278. **Perry, A. C., I. J. Nicolson, and J. R. Saunders.** 1988. *Neisseria meningitidis* C114 contains silent, truncated pilin genes that are homologous to *Neisseria gonorrhoeae pil* sequences. *J. Bacteriol.* **170**:1691–1697.
279. **Plasterk, R. H., R. Kanaar, and P. van de Putte.** 1984. A genetic switch in vitro: DNA inversion by Gin protein of phage Mu. *Proc. Natl. Acad. Sci. USA* **81**:2689–2692.
280. **Pontius, L. T., and D. B. Clewell.** 1991. A phase variation event that activates conjugation functions encoded by the *Enterococcus faecalis* plasmid pAD1. *Plasmid* **26**:172–185.
281. **Prasadarao, N. V., E. Lysenko, C. A. Wass, K. S. Kim, and J. N. Weiser.** 1999. Opacity-associated protein A contributes to the binding of *Haemophilus influenzae* to chondroepithelial cells. *Infect. Immun.* **67**:4153–4160.
282. **Pratt, L. A., and R. Kolter.** 1998. Genetic analysis of *Escherichia coli* biofilm formation: roles of flagella, motility, chemotaxis and type I pili. *Mol. Microbiol.* **30**:285–293.
283. **Preston, A., R. E. Mandrell, B. W. Gibson, and M. A. Apicella.** 1996. The lipooligosaccharides of pathogenic gram-negative bacteria. *Crit. Rev. Microbiol.* **22**:139–180.
284. **Puopolo, K. M., S. K. Hollingshead, V. J. Carey, and L. C. Madoff.** 2001. Tandem repeat deletion in the alpha C protein of group B Streptococcus is *recA* independent. *Infect. Immun.* **69**:5037–5045.
285. **Rasmussen, M., and L. Björck.** 2001. Unique regulation of SclB—a novel collagen-like surface protein of *Streptococcus pyogenes*. *Mol. Microbiol.* **40**:1427–1438.
286. **Ray, K. C., Z. C. Tu, R. Grogono-Thomas, D. G. Newell, S. A. Thompson, and M. J. Blaser.** 2000. *Campylobacter fetus* *sap* inversion occurs in the absence of RecA function. *Infect. Immun.* **68**:5663–5667.
287. **Rest, R. F., and R. E. Mandrell.** 1995. *Neisseria* sialyltransferases and their role in pathogenesis. *Microb. Pathog.* **19**:379–390.
288. **Restrepo, B. I., and A. G. Barbour.** 1994. Antigen diversity in the bacterium *B. hermsii* through “somatic” mutations in rearranged *vmp* genes. *Cell* **78**:867–876.
289. **Restrepo, B. I., C. J. Carter, and A. G. Barbour.** 1994. Activation of a *vmp* pseudogene in *Borrelia hermsii*: an alternate mechanism of antigenic variation during relapsing fever. *Mol. Microbiol.* **13**:287–299.
290. **Richardson, A. R., and I. Stojiljkovic.** 1999. HmbR, a hemoglobin-binding outer membrane protein of *Neisseria meningitidis*, undergoes phase variation. *J. Bacteriol.* **181**:2067–2074.
291. **Richardson, A. R., and I. Stojiljkovic.** 2001. Mismatch repair and the regulation of phase variation in *Neisseria meningitidis*. *Mol. Microbiol.* **40**:645–655.
292. **Ring, A., J. N. Weiser, and E. I. Tuomanen.** 1998. Pneumococcal trafficking across the blood-brain barrier. Molecular analysis of a novel bidirectional pathway. *J. Clin. Investig.* **102**:347–360.
293. **Ritter, A., D. L. Gally, P. B. Olsen, U. Dobrindt, A. Friedrich, P. Klemm, and J. Hacker.** 1997. The *Pai*-associated *leuX* specific tRNAs(Leu) affects type 1 fimbriation in pathogenic *Escherichia coli* by control of FimB recombinase expression. *Mol. Microbiol.* **25**:871–882.
294. **Ritz, D., J. Lim, C. M. Reynolds, L. B. Poole, and J. Beckwith.** 2001. Conversion of a peroxiredoxin into a disulfide reductase by a triplet repeat expansion. *Science* **294**:158–160.
295. **Roche, A., J. McFadden, and P. Owen.** 2001. Antigen 43, the major phase-variable protein of the *Escherichia coli* outer membrane, can exist as a family of proteins encoded by multiple alleles. *Microbiology* **147**:161–169.
296. **Roche, R. J., and E. R. Moxon.** 1995. Phenotypic variation in *Haemophilus influenzae*: the interrelationship of colony opacity, capsule and lipopolysaccharide. *Microb. Pathog.* **18**:129–140.
297. **Roche, R. J., and E. R. Moxon.** 1995. Phenotypic variation of carbohydrate surface antigens and the pathogenesis of *Haemophilus influenzae* infections. *Trends Microbiol.* **3**:304–309.
298. **Roesch, P. L., and I. C. Blomfield.** 1998. Leucine alters the interaction of the leucine-responsive regulatory protein (Lrp) with the *fim* switch to stimulate site-specific recombination in *Escherichia coli*. *Mol. Microbiol.* **27**:751–761.
299. **Rosengarten, R., and K. S. Wise.** 1990. Phenotypic switching in mycoplasmas: phase variation of diverse surface lipoproteins. *Science* **247**:315–318.
300. **Rosengarten, R., and K. S. Wise.** 1991. The Vlp system of *Mycoplasma hyorhinis*: combinatorial expression of distinct size variant lipoproteins generating high-frequency surface antigenic variation. *J. Bacteriol.* **173**:4782–4793.
301. **Roske, K., A. Blanchard, I. Chambaud, C. Citti, J. H. Helbig, M. C. Prevost, R. Rosengarten, and E. Jacobs.** 2001. Phase variation among major surface antigens of *Mycoplasma penetrans*. *Infect. Immun.* **69**:7642–7651.
302. **Rozsa, F. W., and C. F. Marrs.** 1991. Interesting sequence differences between the pilin gene inversion regions of *Moraxella lacunata* ATCC 17956 and *Moraxella bovis* Epp63. *J. Bacteriol.* **173**:4000–4006.
303. **Rudel, T., I. Scheurerpflug, and T. F. Meyer.** 1995. *Neisseria* PilC protein identified as type-4 pilus tip-located adhesin. *Nature* **373**:357–359.
304. **Ryan, K. A., and R. Y. Lo.** 1999. Characterization of a CACAG pentanucleotide repeat in *Pasteurella haemolytica* and its possible role in modulation of a novel type III restriction-modification system. *Nucleic Acids Res.* **27**:1505–1511.
305. **Sarkari, J., N. Pandit, E. R. Moxon, and M. Achtman.** 1994. Variable expression of the Opc outer membrane protein in *Neisseria meningitidis* is caused by size variation of a promoter containing poly-cytidine. *Mol. Microbiol.* **13**:207–217.
306. **Sauer, F. G., M. A. Mulvey, J. D. Schilling, J. J. Martinez, and S. J.**

- Hultgren. 2000. Bacterial pili: molecular mechanisms of pathogenesis. *Curr. Opin. Microbiol.* **3**:65–72.
307. Saunders, N. J., A. C. Jeffries, J. F. Peden, D. W. Hood, H. Tettelin, R. Rappuoli, and E. R. Moxon. 2000. Repeat-associated phase variable genes in the complete genome sequence of *Neisseria meningitidis* strain MC58. *Mol. Microbiol.* **37**:207–215.
308. Saunders, N. J., E. R. Moxon, and M. B. Gravenor. 2003. Mutation rates: estimating phase variation rates when fitness differences are present and their impact on population structure. *Microbiology* **149**:485–495.
309. Saunders, N. J., J. F. Peden, D. W. Hood, and E. R. Moxon. 1998. Simple sequence repeats in the *Helicobacter pylori* genome. *Mol. Microbiol.* **27**:1091–1098.
310. Schembri, M. A., L. Hjerrild, M. Gjermansen, and P. Klemm. 2003. Differential expression of the *Escherichia coli* autoaggregation factor antigen 43. *J. Bacteriol.* **185**:2236–2242.
311. Schembri, M. A., and P. Klemm. 2001. Coordinate gene regulation by fimbriae-induced signal transduction. *EMBO J.* **20**:3074–3081.
312. Scheuerpflug, I., T. Rudel, R. Ryll, J. Pandit, and T. F. Meyer. 1999. Roles of PilC and PilE proteins in pilus-mediated adherence of *Neisseria gonorrhoeae* and *Neisseria meningitidis* to human erythrocytes and endothelial and epithelial cells. *Infect. Immun.* **67**:834–843.
313. Schilling, J. D., M. A. Mulvey, and S. J. Hultgren. 2001. Structure and function of *Escherichia coli* type 1 pili: new insight into the pathogenesis of urinary tract infections. *J. Infect. Dis.* **183**(Suppl. 1):S36–S40.
314. Scholten, R. J., B. Kuipers, H. A. Valkenburg, J. Dankert, W. D. Zollinger, and J. T. Poolman. 1994. Lipid-oligosaccharide immunotyping of *Neisseria meningitidis* by a whole-cell ELISA with monoclonal antibodies. *J. Med. Microbiol.* **41**:236–243.
315. Schweda, E. K., J. R. Brisson, G. Alvelius, A. Martin, J. N. Weiser, D. W. Hood, E. R. Moxon, and J. C. Richards. 2000. Characterization of the phosphocholine-substituted oligosaccharide in lipopolysaccharides of type b *Haemophilus influenzae*. *Eur. J. Biochem.* **267**:3902–3913.
316. Scott, T. N., and M. I. Simon. 1982. Genetic analysis of the mechanism of the *Salmonella* phase variation site specific recombination system. *Mol. Gen. Genet.* **188**:313–321.
317. Segal, E., E. Billyard, M. So, S. Storzbach, and T. F. Meyer. 1985. Role of chromosomal rearrangement in *N. gonorrhoeae* pilus phase variation. *Cell* **40**:293–300.
318. Segal, E., P. Hagblom, H. S. Seifert, and M. So. 1986. Antigenic variation of gonococcal pilus involves assembly of separated silent gene segments. *Proc. Natl. Acad. Sci. USA* **83**:2177–2181.
319. Seifert, H. S. 1996. Questions about gonococcal pilus phase- and antigenic variation. *Mol. Microbiol.* **21**:433–440.
320. Seifert, H. S., C. J. Wright, A. E. Jerse, M. S. Cohen, and J. G. Cannon. 1994. Multiple gonococcal pilin antigenic variants are produced during experimental human infections. *J. Clin. Invest.* **93**:2744–2749.
321. Serino, L., and M. Virji. 2002. Genetic and functional analysis of the phosphorylcholine moiety of commensal *Neisseria* lipopolysaccharide. *Mol. Microbiol.* **43**:437–448.
322. Serino, L., and M. Virji. 2000. Phosphorylcholine decoration of lipopolysaccharide differentiates commensal neisseriae from pathogenic strains: identification of *licA*-type genes in commensal neisseriae. *Mol. Microbiol.* **35**:1550–1559.
323. Serkin, C. D., and H. S. Seifert. 2000. Iron availability regulates DNA recombination in *Neisseria gonorrhoeae*. *Mol. Microbiol.* **37**:1075–1086.
324. Shafer, W. M., A. Datta, V. S. Kolli, M. M. Rahman, J. T. Balthazar, L. E. Martin, W. L. Veal, D. S. Stephens, and R. Carlson. 2002. Phase variable changes in genes *lgtA* and *lgtC* within the *lgtABCDE* operon of *Neisseria gonorrhoeae* can modulate gonococcal susceptibility to normal human serum. *J. Endotoxin Res.* **8**:47–58.
325. Shen, X., J. Gumulak, H. Yu, C. T. French, N. Zou, and K. Dybvig. 2000. Gene rearrangements in the *vsa* locus of *Mycoplasma pulmonis*. *J. Bacteriol.* **182**:2900–2908.
326. Silverman, M., J. Zieg, M. Hilmen, and M. Simon. 1979. Phase variation in *Salmonella*: genetic analysis of a recombinational switch. *Proc. Natl. Acad. Sci. USA* **76**:391–395.
327. Silverman, M., J. Zieg, and M. Simon. 1979. Flagellar-phase variation: isolation of the *rhI* gene. *J. Bacteriol.* **137**:517–523.
328. Simon, M., J. Zieg, M. Silverman, G. Mandel, and R. Doolittle. 1980. Phase variation: evolution of a controlling element. *Science* **209**:1370–1374.
329. Simpson, W. J., D. LaPenta, C. Chen, and P. P. Cleary. 1990. Coregulation of type 12 M protein and streptococcal C5a peptidase genes in group A streptococci: evidence for a virulence regulon controlled by the *virR* locus. *J. Bacteriol.* **172**:696–700.
330. Sitaraman, R., A. M. Denison, and K. Dybvig. 2002. A unique, bifunctional site-specific DNA recombinase from *Mycoplasma pulmonis*. *Mol. Microbiol.* **46**:1033–1040.
331. Sitaraman, R., and K. Dybvig. 1997. The *hsd* loci of *Mycoplasma pulmonis*: organization, rearrangements and expression of genes. *Mol. Microbiol.* **26**:109–120.
332. Skaar, E. P., M. P. Lazio, and H. S. Seifert. 2002. Roles of the *recJ* and *recN* genes in homologous recombination and DNA repair pathways of *Neisseria gonorrhoeae*. *J. Bacteriol.* **184**:919–927.
333. Smith, B. P., G. W. Dilling, J. K. House, H. Konrad, and N. Moore. 1995. Enzyme-linked immunosorbent assay for *Salmonella* serology using lipopolysaccharide antigen. *J. Vet. Diagn. Investig.* **7**:481–487.
334. Snyder, L. A., S. A. Butcher, and N. J. Saunders. 2001. Comparative whole-genome analyses reveal over 100 putative phase-variable genes in the pathogenic *Neisseria* spp. *Microbiology* **147**:2321–2332.
335. Sohampal, B. K., H. D. Kulasekara, A. Bonnen, and I. C. Blomfield. 2001. Orientational control of *fimE* expression in *Escherichia coli*. *Mol. Microbiol.* **42**:483–494.
336. Sojka, W. J., and H. I. Field. 1970. Salmonellosis in England and Wales 1958–1967. *Vet. Bull.* **40**:515–531.
337. Sojka, W. J., and C. Wray. 1975. Incidence of *Salmonella* infection in animals in England and Wales, 1968–73. *Vet. Rec.* **96**:280–284.
338. Sojka, W. J., C. Wray, and I. McLaren. 1986. A survey of drug resistance in salmonellae isolated from animals in England and Wales in 1982 and 1983. *Br. Vet. J.* **142**:371–380.
339. Stern, A., and T. F. Meyer. 1987. Common mechanism controlling phase and antigenic variation in pathogenic neisseriae. *Mol. Microbiol.* **1**:5–12.
340. Stibitz, S., W. Aaronson, D. Monack, and S. Falkow. 1989. Phase variation in *Bordetella pertussis* by frameshift mutation in a gene for a novel two-component system. *Nature* **338**:266–269.
341. Stoenner, H. G., T. Dodd, and C. Larsen. 1982. Antigenic variation of *Borrelia hermsii*. *J. Exp. Med.* **156**:1297–1311.
342. Stohl, E. A., and H. S. Seifert. 2001. The *recX* gene potentiates homologous recombination in *Neisseria gonorrhoeae*. *Mol. Microbiol.* **40**:1301–1310.
343. Struve, C., and K. A. Krogfelt. 1999. In vivo detection of *Escherichia coli* type 1 fimbrial expression and phase variation during experimental urinary tract infection. *Microbiology* **145**:2683–2690.
344. Sumbly, P., and M. C. Smith. 2003. Phase variation in the phage growth limitation system of *Streptomyces coelicolor* A3(2). *J. Bacteriol.* **185**:4558–4563.
345. Swanson, J., O. Barrera, J. Sola, and J. Boslego. 1988. Expression of outer membrane protein II by gonococci in experimental gonorrhoea. *J. Exp. Med.* **168**:2121–2129.
346. Swanson, J., R. J. Belland, and S. A. Hill. 1992. Neisserial surface variation: how and why? *Curr. Opin. Genet. Dev.* **2**:805–811.
347. Tannaes, T., N. Dekker, G. Bukholm, J. J. Bijlsma, and B. J. Appelmek. 2001. Phase variation in the *Helicobacter pylori* phospholipase A gene and its role in acid adaptation. *Infect. Immun.* **69**:7334–7340.
348. Tannaes, T., H. J. Grav, and G. Bukholm. 2000. Lipid profiles of *Helicobacter pylori* colony variants. *APMIS* **108**:349–356.
349. Tettelin, H., K. E. Nelson, I. T. Paulsen, J. A. Eisen, T. D. Read, S. Peterson, J. Heidelberg, R. T. DeBoy, D. H. Haft, R. J. Dodson, A. S. Durkin, M. Gwinn, J. F. Kolonay, W. C. Nelson, J. D. Peterson, L. A. Umayam, O. White, S. L. Salzberg, M. R. Lewis, D. Radune, E. Holtzapple, H. Khouri, A. M. Wolf, T. R. Utterback, C. L. Hansen, L. A. McDonald, T. V. Feldblyum, S. Angiuoli, T. Dickinson, E. K. Hickey, I. E. Holt, B. J. Loftus, F. Yang, H. O. Smith, J. C. Venter, B. A. Dougherty, D. A. Morrison, S. K. Hollingshead, and C. M. Fraser. 2001. Complete genome sequence of a virulent isolate of *Streptococcus pneumoniae*. *Science* **293**:498–506.
350. Tettelin, H., N. J. Saunders, J. Heidelberg, A. C. Jeffries, K. E. Nelson, J. A. Eisen, K. A. Ketchum, D. W. Hood, J. F. Peden, R. J. Dodson, W. C. Nelson, M. L. Gwinn, R. DeBoy, J. D. Peterson, E. K. Hickey, D. H. Haft, S. L. Salzberg, O. White, R. D. Fleischmann, B. A. Dougherty, T. Mason, A. Ciekco, D. S. Parksey, E. Blair, H. Cittyne, E. B. Clark, M. D. Cotton, T. R. Utterback, H. Khouri, H. Qin, J. Vamathevan, J. Gill, V. Scarlato, V. Masignani, M. Pizza, G. Grandi, L. Sun, H. O. Smith, C. M. Fraser, E. R. Moxon, R. Rappuoli, and J. C. Venter. 2000. Complete genome sequence of *Neisseria meningitidis* serogroup B strain MC58. *Science* **287**:1809–1815.
351. Theiss, P., and K. S. Wise. 1997. Localized frameshift mutation generates selective, high-frequency phase variation of a surface lipoprotein encoded by a *Mycoplasma* ABC transporter operon. *J. Bacteriol.* **179**:4013–4022.
352. Tinsley, C. R., and J. E. Heckels. 1986. Variation in the expression of pili and outer membrane protein by *Neisseria meningitidis* during the course of meningococcal infection. *J. Gen. Microbiol.* **132**:2483–2490.
353. Tobiasson, D. M., J. M. Buchner, W. H. Thiel, K. M. Gernert, and A. C. Karls. 2001. Conserved amino acid motifs from the novel Piv/MooV family of transposases and site-specific recombinases are required for catalysis of DNA inversion by Piv. *Mol. Microbiol.* **39**:641–651.
354. Tomb, J. F., O. White, A. R. Kerlavage, R. A. Clayton, G. G. Sutton, R. D. Fleischmann, K. A. Ketchum, H. P. Klenk, S. Gill, B. A. Dougherty, K. Nelson, J. Quackenbush, L. Zhou, E. F. Kirkness, S. Peterson, B. Loftus, D. Richardson, R. Dodson, H. G. Khalak, A. Glodek, K. McKenney, L. M. Fitzgerald, N. Lee, M. D. Adams, J. C. Venter, et al. 1997. The complete genome sequence of the gastric pathogen *Helicobacter pylori*. *Nature* **388**:539–547.
355. Tommassen, J., P. Vermeij, M. Struyve, R. Benz, and J. T. Poolman. 1990. Isolation of *Neisseria meningitidis* mutants deficient in class 1 (*porA*) and class 3 (*porB*) outer membrane proteins. *Infect. Immun.* **58**:1355–1359.
356. Torres-Cruz, J., and M. W. Van der Woude. 2003. Slipped-strand mispair-

- ing can function as a phase variation mechanism in *Escherichia coli*. J. Bacteriol. **185**:6990–6994.
357. Townsend, S. M., N. E. Kramer, R. Edwards, S. Baker, N. Hamlin, M. Simmonds, K. Stevens, S. Maloy, J. Parkhill, G. Dougan, and A. J. Baumber. 2001. *Salmonella enterica* serovar Typhi possesses a unique repertoire of fimbrial gene sequences. Infect. Immun. **69**:2894–2901.
358. Turner, C. M. 2002. A perspective on clonal phenotypic (antigenic) variation in protozoan parasites. Parasitology **125**(Suppl):S17–S23.
359. van Belkum, A. 1999. The role of short sequence repeats in epidemiologic typing. Curr. Opin. Microbiol. **2**:306–311.
360. van Belkum, A., S. Scherer, L. van Alphen, and H. Verbrugh. 1998. Short-sequence DNA repeats in prokaryotic genomes. Microbiol. Mol. Biol. Rev. **62**:275–293.
361. van Belkum, A., S. Scherer, W. van Leeuwen, D. Willemse, L. van Alphen, and H. Verbrugh. 1997. Variable number of tandem repeats in clinical strains of *Haemophilus influenzae*. Infect. Immun. **65**:5017–5027.
362. van Belkum, A., W. van Leeuwen, S. Scherer, and H. Verbrugh. 1999. Occurrence and structure-function relationship of pentameric short sequence repeats in microbial genomes. Res. Microbiol. **150**:617–626.
363. van de Putte, P., S. Cramer, and M. Giphart-Gasser. 1980. Invertible DNA determines host specificity of bacteriophage mu. Nature **286**:218–222.
364. van de Putte, P., and N. Goosen. 1992. DNA inversions in phages and bacteria. Trends Genet. **8**:457–462.
365. van der Ende, A., C. T. Hopman, and J. Dankert. 2000. Multiple mechanisms of phase variation of PorA in *Neisseria meningitidis*. Infect. Immun. **68**:6685–6690.
366. van der Ende, A., C. T. Hopman, S. Zaat, B. B. Essink, B. Berkhout, and J. Dankert. 1995. Variable expression of class 1 outer membrane protein in *Neisseria meningitidis* is caused by variation in the spacing between the –10 and –35 regions of the promoter. J. Bacteriol. **177**:2475–2480.
367. van der Velden, A. W., A. J. Baumber, R. M. Tsolis, and F. Heffron. 1998. Multiple fimbrial adhesins are required for full virulence of *Salmonella typhimurium* in mice. Infect. Immun. **66**:2803–2808.
368. van der Woude, M., B. Braaten, and D. A. Low. 1996. Epigenetic phase variation of the *pap* operon in *Escherichia coli*. Trends Microbiol. **4**:5–9.
369. van der Woude, M. W., B. A. Braaten, and D. A. Low. 1992. Evidence for global regulatory control of pilus expression in *Escherichia coli* by Lrp and DNA methylation: model building based on analysis of *pap*. Mol. Microbiol. **6**:2429–2435.
370. van der Woude, M. W., L. S. Kaltenbach, and D. A. Low. 1995. Leucine-responsive regulatory protein plays dual roles as both an activator and a repressor of the *Escherichia coli pap* fimbrial operon. Mol. Microbiol. **17**:303–312.
371. van der Woude, M. W., and D. A. Low. 1994. Leucine-responsive regulatory protein and deoxyadenosine methylase control the phase variation and expression of the *sfa* and *daa* pili operons in *Escherichia coli*. Mol. Microbiol. **11**:605–618.
372. van Ham, S. M., L. van Alphen, F. R. Mooi, and J. P. van Putten. 1993. Phase variation of *H. influenzae* fimbriae: transcriptional control of two divergent genes through a variable combined promoter region. Cell **73**:1187–1196.
373. van Putten, J. P., and S. M. Paul. 1995. Binding of syndecan-like cell surface proteoglycan receptors is required for *Neisseria gonorrhoeae* entry into human mucosal cells. EMBO J. **14**:2144–2154.
374. Vickerman, M. M., G. W. Jones, and D. B. Clewell. 1997. Molecular analysis of representative *Streptococcus gordonii* spp. phase variants reveals no differences in the glycosyltransferase structural gene, *gtfG*. Oral Microbiol. Immunol. **12**:82–90.
375. Virji, M., S. M. Watt, S. Barker, K. Makepeace, and R. Doyonnas. 1996. The N-domain of the human CD66a adhesion molecule is a target for Opa proteins of *Neisseria meningitidis* and *Neisseria gonorrhoeae*. Mol. Microbiol. **22**:929–939.
376. Wainwright, L. A., J. V. Frangipane, and H. S. Seifert. 1997. Analysis of protein binding to the Sma/Cla DNA repeat in pathogenic neisseriae. Nucleic Acids Res. **25**:1362–1368.
377. Wainwright, L. A., K. H. Pritchard, and H. S. Seifert. 1994. A conserved DNA sequence is required for efficient gonococcal pilin antigenic variation. Mol. Microbiol. **13**:75–87.
378. Waite, R. D., D. W. Penfold, J. K. Struthers, and C. G. Dowson. 2003. Spontaneous sequence duplications within capsule genes *cap8E* and *ts* control phase variation in *Streptococcus pneumoniae* serotypes 8 and 37. Microbiology **149**:497–504.
379. Waite, R. D., J. K. Struthers, and C. G. Dowson. 2001. Spontaneous sequence duplication within an open reading frame of the pneumococcal type 3 capsule locus causes high-frequency phase variation. Mol. Microbiol. **42**:1223–1232.
380. Waldron, D. E., P. Owen, and C. J. Dorman. 2002. Competitive interaction of the OxyR DNA-binding protein and the Dam methylase at the antigen 43 gene regulatory region in *Escherichia coli*. Mol. Microbiol. **44**:509–520.
381. Wall, D., and D. Kaiser. 1999. Type IV pili and cell motility. Mol. Microbiol. **32**:1–10.
382. Wallecha, A., J. Correnti, V. Munster, and M. Van Der Woude. 2003. Phase variation of Ag43 is independent of the oxidation state of OxyR. J. Bacteriol. **185**:2203–2209.
383. Wallecha, A., V. Munster, J. Correnti, T. Chan, and M. W. van der Woude. 2002. Dam- and OxyR dependent phase variation of *agn43*: essential elements and evidence for a new role of DNA methylation. J. Bacteriol. **184**:3338–3347.
384. Wang, G., Z. Ge, D. A. Rasko, and D. E. Taylor. 2000. Lewis antigens in *Helicobacter pylori*: biosynthesis and phase variation. Mol. Microbiol. **36**:1187–1196.
385. Wang, G., D. A. Rasko, R. Sherburne, and D. E. Taylor. 1999. Molecular genetic basis for the variable expression of Lewis Y antigen in *Helicobacter pylori*: analysis of the alpha-(1,2)-fucosyltransferase gene. Mol. Microbiol. **31**:1265–1274.
386. Wassenaar, T. M., J. A. Wagenaar, A. Rigter, C. Fearnley, D. G. Newell, and B. Duim. 2002. Homonucleotide stretches in chromosomal DNA of *Campylobacter jejuni* display high frequency polymorphism as detected by direct PCR analysis. FEMS Microbiol. Lett. **212**:77–85.
387. Weiser, J. N., R. Austrian, P. K. Sreenivasan, and H. R. Masure. 1994. Phase variation in pneumococcal opacity: relationship between colonial morphology and nasopharyngeal colonization. Infect. Immun. **62**:2582–2589.
388. Weiser, J. N., S. T. Chong, D. Greenberg, and W. Fong. 1995. Identification and characterization of a cell envelope protein of *Haemophilus influenzae* contributing to phase variation in colony opacity and nasopharyngeal colonization. Mol. Microbiol. **17**:555–564.
389. Weiser, J. N., J. B. Goldberg, N. Pan, L. Wilson, and M. Virji. 1998. The phosphorylcholine epitope undergoes phase variation on a 43-kilodalton protein in *Pseudomonas aeruginosa* and on pili of *Neisseria meningitidis* and *Neisseria gonorrhoeae*. Infect. Immun. **66**:4263–4267.
390. Weiser, J. N., J. M. Love, and E. R. Moxon. 1989. The molecular mechanism of phase variation of *H. influenzae* lipopolysaccharide. Cell **59**:657–665.
391. Weiser, J. N., D. J. Maskell, P. D. Butler, A. A. Lindberg, and E. R. Moxon. 1990. Characterization of repetitive sequences controlling phase variation of *Haemophilus influenzae* lipopolysaccharide. J. Bacteriol. **172**:3304–3309.
392. Weiser, J. N., and N. Pan. 1998. Adaptation of *Haemophilus influenzae* to acquired and innate humoral immunity based on phase variation of lipopolysaccharide. Mol. Microbiol. **30**:767–775.
393. Weiser, J. N., N. Pan, K. L. McGowan, D. Musher, A. Martin, and J. Richards. 1998. Phosphorylcholine on the lipopolysaccharide of *Haemophilus influenzae* contributes to persistence in the respiratory tract and sensitivity to serum killing mediated by C-reactive protein. J. Exp. Med. **187**:631–640.
394. Weiser, J. N., M. Shchepetov, and S. T. Chong. 1997. Decoration of lipopolysaccharide with phosphorylcholine: a phase-variable characteristic of *Haemophilus influenzae*. Infect. Immun. **65**:943–950.
395. Weiser, J. N., A. Williams, and E. R. Moxon. 1990. Phase-variable lipopolysaccharide structures enhance the invasive capacity of *Haemophilus influenzae*. Infect. Immun. **58**:3455–3457.
396. Weyand, N. J., B. A. Braaten, M. van der Woude, J. Tucker, and D. A. Low. 2001. The essential role of the promoter-proximal subunit of CAP in *pap* phase variation: Lrp- and helical phase-dependent activation of *papBA* transcription by CAP from –215. Mol. Microbiol. **39**:1504–1522.
397. Weyand, N. J., and D. A. Low. 2000. Regulation of *Pap* phase variation. Lrp is sufficient for the establishment of the phase off *pap* DNA methylation pattern and repression of *pap* transcription in vitro. J. Biol. Chem. **275**:3192–3200.
398. White-Ziegler, C. A., M. L. Angus Hill, B. A. Braaten, M. W. van der Woude, and D. A. Low. 1998. Thermoregulation of *E. coli pap* transcription: H-NS is a temperature-dependent DNA methylation blocking factor. Mol. Microbiol. **28**:1121–1138.
399. White-Ziegler, C. A., A. Villapakkam, K. Ronaszeki, and S. Young. 2000. H-NS controls *pap* and *daa* fimbrial transcription in *Escherichia coli* in response to multiple environmental cues. J. Bacteriol. **182**:6391–6400.
400. Willems, R., A. Paul, H. G. van der Heide, A. R. ter Avest, and F. R. Mooi. 1990. Fimbrial phase variation in *Bordetella pertussis*: a novel mechanism for transcriptional regulation. EMBO J. **9**:2803–2809.
401. Winner, F., I. Markova, P. Much, A. Lugmair, K. Siebert-Gulle, G. Vogl, R. Rosengarten, and C. Citti. 2003. Phenotypic switching in *Mycoplasma gallisepticum* hemadsorption is governed by a high-frequency, reversible point mutation. Infect. Immun. **71**:1265–1273.
402. Wu, Y., J. H. McQuiston, A. Cox, T. D. Pack, and T. J. Inzana. 2000. Molecular cloning and mutagenesis of a DNA locus involved in lipooligosaccharide biosynthesis in *Haemophilus somnus*. Infect. Immun. **68**:310–319.
403. Xia, Y., D. Gally, K. Forsman-Semb, and B. E. Uhlin. 2000. Regulatory cross-talk between adhesion operons in *Escherichia coli*: inhibition of type 1 fimbriae expression by the PapB protein. EMBO J. **19**:1450–1457.
404. Yang, Q. L., and E. C. Gotschlich. 1996. Variation of gonococcal lipooligosaccharide structure is due to alterations in poly-G tracts in *lgt* genes encoding glycosyl transferases. J. Exp. Med. **183**:323–327.
405. Yeh, K. S., J. K. Tinker, and S. Clegg. 2002. FimZ binds the *Salmonella typhimurium fimA* promoter region and may regulate its own expression with FimY. Microbiol. Immunol. **46**:1–10.

406. **Yi, K., D. S. Stephens, and I. Stojiljkovic.** 2003. Development and evaluation of an improved mouse model of meningococcal colonization. *Infect. Immun.* **71**:1849–1855.
407. **Yogev, D., D. Menaker, K. Strutzberg, S. Levisohn, H. Kirchhoff, K. H. Hinz, and R. Rosengarten.** 1994. A surface epitope undergoing high-frequency phase variation is shared by *Mycoplasma gallisepticum* and *Mycoplasma bovis*. *Infect. Immun.* **62**:4962–4968.
408. **Yogev, D., R. Rosengarten, R. Watson-McKown, and K. S. Wise.** 1991. Molecular basis of *Mycoplasma* surface antigenic variation: a novel set of divergent genes undergo spontaneous mutation of periodic coding regions and 5' regulatory sequences. *EMBO J.* **10**:4069–4079.
409. **Yogev, D., R. Watson-McKown, R. Rosengarten, J. Im, and K. S. Wise.** 1995. Increased structural and combinatorial diversity in an extended family of genes encoding Vlp surface proteins of *Mycoplasma hyorhinis*. *J. Bacteriol.* **177**:5636–5643.
410. **Young, D., T. Hussell, and G. Dougan.** 2002. Chronic bacterial infections: living with unwanted guests. *Nat. Immunol.* **3**:1026–1032.
411. **Zhang, J. R., J. M. Hardham, A. G. Barbour, and S. J. Norris.** 1997. Antigenic variation in Lyme disease borreliae by promiscuous recombination of VMP-like sequence cassettes. *Cell* **89**:275–285.
412. **Zhang, J. R., and S. J. Norris.** 1998. Genetic variation of the *Borrelia burgdorferi* gene *vlsE* involves cassette-specific, segmental gene conversion. *Infect. Immun.* **66**:3698–3704.
413. **Zhang, Q. Y., D. DeRyckere, P. Lauer, and M. Koomey.** 1992. Gene conversion in *Neisseria gonorrhoeae*: evidence for its role in pilus antigenic variation. *Proc. Natl. Acad. Sci. USA* **89**:5366–5370.
414. **Zhang, X. L., C. Morris, and J. Hackett.** 1997. Molecular cloning, nucleotide sequence, and function of a site-specific recombinase encoded in the major 'pathogenicity island' of *Salmonella typhi*. *Gene* **202**:139–146.
415. **Zhang, X. L., I. S. Tsui, C. M. Yip, A. W. Fung, D. K. Wong, X. Dai, Y. Yang, J. Hackett, and C. Morris.** 2000. *Salmonella enterica* serovar: Typhi uses type IVB pili to enter human intestinal epithelial cells. *Infect. Immun.* **68**:3067–3073.
416. **Zhao, H., X. Li, D. E. Johnson, I. Blomfield, and H. L. Mobley.** 1997. In vivo phase variation of MR/P fimbrial gene expression in *Proteus mirabilis* infecting the urinary tract. *Mol. Microbiol.* **23**:1009–1019.
417. **Zhu, P., M. J. Klutch, M. C. Bash, R. S. Tsang, L. K. Ng, and C. M. Tsai.** 2002. Genetic diversity of three *lgt* loci for biosynthesis of lipooligosaccharide (LOS) in *Neisseria* species. *Microbiology* **148**:1833–1844.
418. **Zhu, P., C. M. Tsai, and C. E. Frasch.** 2002. Immunologic and genetic characterization of lipooligosaccharide variants in a *Neisseria meningitidis* serogroup C strain. *FEMS Immunol. Med. Microbiol.* **34**:193–200.
419. **Ziebuhr, W., C. Heilmann, F. Gotz, P. Meyer, K. Wilms, E. Straube, and J. Hacker.** 1997. Detection of the intercellular adhesion gene cluster (*ica*) and phase variation in *Staphylococcus epidermidis* blood culture strains and mucosal isolates. *Infect. Immun.* **65**:890–896.
420. **Ziebuhr, W., V. Krimmer, S. Rachid, I. Lossner, F. Gotz, and J. Hacker.** 1999. A novel mechanism of phase variation of virulence in *Staphylococcus epidermidis*: evidence for control of the polysaccharide intercellular adhesin synthesis by alternating insertion and excision of the insertion sequence element IS256. *Mol. Microbiol.* **32**:345–356.
421. **Zollinger, W. D., and R. E. Mandrell.** 1977. Outer-membrane protein and lipopolysaccharide serotyping of *Neisseria meningitidis* by inhibition of a solid-phase radioimmunoassay. *Infect. Immun.* **18**:424–433.