

Phase Transfer Catalysis: Chemistry and Engineering

Sanjeev D. Naik and L. K. Doraiswamy

Dept. of Chemical Engineering, Iowa State University, Ames, IA 50011

Phase transfer catalysis (PTC) uses catalytic amounts of phase transfer agents which facilitate interphase transfer of species, making reactions between reagents in two immiscible phases possible. PTC is used widely in the synthesis of various organic chemicals in both liquid-liquid and solid-liquid systems. Existing literature on PTC is chemistry-intensive and a mere handful of recent articles constitute the entire information on engineering analysis. This article reviews the field comprehensively by combining the existing knowledge from chemistry with insights into mechanistic and kinetic analysis and mathematical modeling of soluble and insoluble PTC. By its very nature, PTC involves a series of equilibrium and mass-transfer steps, beside the two main reactions. Neglect of mass-transfer effects can grossly over-predict the conversion of a PTC mediated reaction. A practical way of using PTC, which enables easy separation, is to immobilize the catalyst on a solid support. Mass-transfer limitations and higher costs, however, have precluded its commercial use so far, requiring further analysis of mass-transfer limitations in these complex three-phase systems. The use of PTC, combined with other rate enhancement techniques like sonochemistry, microwaves, electroorganic synthesis, and photochemistry, is being increasingly explored. Applications in this area in the manufacture of organic intermediates and fine chemicals seem almost unlimited.

Introduction

The principle of phase transfer catalysis (PTC) is brought forth well by Reuben and Sjoberg (1981) who write that all boundaries are difficult to cross: political, legal and geographic boundaries, and also phase boundaries in chemical systems. Many desirable reactions cannot be brought about because the reactants are inaccessible to each other. The crucial difficulty of bringing together a water soluble nucleophilic reagent and an organic water insoluble electrophilic reagent has been traditionally solved by the addition of a solvent that is both water-like and organic-like (such as ethanol, which derives its hydrophilic nature from its hydroxyl group and its lipophilicity from the ethyl group). However, rate acceleration is minimal due to excessive solvation of the nucleophile. Alternatively, expensive dipolar aprotic solvents like dimethyl formamide (DMF) or dimethyl sulfoxide (DMSO) can be used, but they suffer from the disadvantages of being difficult and expensive to separate from the reaction mixture

during post-reaction recovery. A feasible and industrially successful method developed over the last quarter century is the use of phase-transfer agents, employed in catalytic amounts, which transfer reactive anions from the aqueous or solid phase into the organic phase, where reaction occurs. PTC has proved to be a very important means of transcending phase barriers in heterogeneous systems. It is an environmentally friendly and economically profitable method of synthesizing a wide variety of organic chemicals, and is extensively used in the fine chemicals industry.

Although the use of agents for anion transfer has been mentioned in some early publications and patents (Jarrouse, 1951), the foundations of PTC were laid in the late 1960s and early 1970s by the studies of Makosza (1975), Starks (1971), and Brandstrom (1977). Starks is believed to have coined the phrase *phase transfer catalysis*, and although some would tend to disagree with calling the PT cycle a catalytic process in the true sense of the word *catalysis*, the terminology has been well established and stays, especially since only catalytic amounts of the phase-transfer agent are required for effective phase-transfer action. In view of the changing active PT

Correspondence concerning this article should be addressed to L. K. Doraiswamy. Current address of S. D. Naik: Chemical Engineering Dept., University of Wisconsin, Madison, WI 53706.

catalyst concentration during the cycle (see modeling studies later), one can perhaps consider it as a catalytic process with changing catalytic activity.

The principle of PTC is based on the ability of certain "phase-transfer agents" (the PT catalysts) to facilitate the transport of one reagent from one phase into another (immiscible) phase wherein the other reagent exists. Thus, reaction is made possible by bringing together the reagents which are originally in different phases. However, it is also necessary that the transferred species is in an active state for effective PT catalytic action, and that it is regenerated during the organic reaction.

Applications of PTC

PTC finds applications in a variety of reactions. Primary applications are in nucleophilic substitution reactions and in reactions in the presence of bases involving the deprotonation of moderately and weakly acidic organic compounds. Reactions carried out using PTC include oxidations, reductions, polymerizations, transition metal co-catalyzed reactions, synthesis of carbenes and further reactions of carbenes, addition reactions, condensations, and so on, which are often part of a multistep synthesis process for fine chemicals manufacture. In the base, mediated alkylation of weakly acidic organic compounds ($pK_a \sim 15-24$) PTC has made possible the use of cheaper and easily available alternative raw materials like potassium carbonate and aqueous NaOH solution, thereby obviating the need of severe anhydrous conditions, expensive solvents, and dangerous bases such as metal hydrides and organometallic reagents. When these reactions are carried out in the presence of a PT catalyst in biphasic systems, simple, cheap and mild bases like NaOH and K_2CO_3 can be used instead of toxic alkali metal alkoxides, amides, and hydrides. For example, C-alkylation of active methylene compounds like activated benzylic nitriles, activated hydrocarbons, and activated ketones under PTC/ OH^- conditions has been pioneered by Makosza (1975,1977), and is widely used in a large number of useful organic reactions. Other advantages of these reactions is an increased selectivity in some cases (Dehmlow, 1995). For example, in carbene reactions in the presence of 50% NaOH, hydrolysis of the organic substrate is prevented due to phase separation.

However, the main disadvantages of PTC, especially in commercial applications, is the need to separate the catalyst from the product organic phase. Some general separation techniques are discussed in the Conclusion Section. Another method to overcome the problems associated with catalyst recovery is to immobilize the PTC on a solid support. This is discussed in the subsection on ultrasound in PTC systems.

Objective of review

It is estimated (Starks et al., 1994) that PTC is used in as many as 500 commercial processes, with sales of products manufactured by processes consisting of at least one major PTC step being at least \$10 billion a year, with wide ranging applications in the pharmaceuticals, agro-based chemicals, and polymer industries.

Despite thousands of publications on the chemistry and applications of PTC, an important yet surprisingly lacking link is a comprehensive kinetic study and mathematical modeling

of PTC reactions. Engineering analysis is limited to a handful of articles on kinetics and modeling of these reactions. Industrial applications of PTC are widespread but remain patented or well guarded secrets. Mere empirical knowledge that has guided much of industrial PTC process development is obviously not adequate for efficient and optimum development of PTC technology.

This article attempts to unify the vast literature on PTC chemistry with a comprehensive review of kinetic studies and mathematical modeling of PTC systems, which necessarily involve the role of intraphase and interphase mass transport. This coupling of knowledge from chemistry with engineering should prove useful in developing rational methods of reactor design and scale-up for commercial PTC applications.

Fundamentals of Phase-Transfer Catalysis

Classification of PTC systems

PTC reactions can be broadly classified into two main classes: soluble PTC and insoluble PTC (Figure 1). Within each class, depending on the actual phases involved, reactions are further classified as liquid-liquid PTC (LLPTC), gas-liquid PTC (GLPTC), and solid-liquid PTC (SLPTC). In some cases, the PT catalyst forms a separate liquid phase, and this variant of PTC can be grouped along with traditional insoluble PTC, where the PT catalyst is immobilized on a solid support. Other nontypical variants of PTC include inverse PTC (IPTC) and reverse PTC via a reverse transfer mechanism (Halpern et al., 1985).

In LLPTC, the nucleophile ($M^+ Y^-$) is dissolved in an aqueous phase, whereas in SLPTC it is a solid suspended in the organic phase. Traditionally, more applications of PTC have been reported in liquid-liquid systems, although there is a distinct advantage in operating in the solid-liquid mode in some reactions since the elimination of the aqueous phase lowers the degree of hydration of the ion pair, leading to an increase in its reactivity. Thus, higher selectivities and yields are sometimes obtained by operating in the solid-liquid mode as compared to operation in the liquid-liquid (aqueous-organic) mode. For example, reaction of phenylacetylene with benzyl bromide in the presence of CO and NaOH with TDA-1 as PT catalyst and a cobalt carbonyl complex as cocatalyst gives phenylacetic acid when operated as a liquid-liquid system due to rapid hydrolysis of the acylcobaltcarbonyl intermediate, whereas using solid NaOH gives the corresponding lactone (Arzoumanian and Petrigiani, 1986). GLPTC involves the use of PTC in gas-liquid-solid systems, where the organic substrate is in a gaseous form and is passed over a bed consisting of the inorganic reagent or some other solid reagent/cocatalyst (commonly, solid K_2CO_3) in solid form (Tundo and Ventureho, 1979), or an inert inorganic support (Tundo et al., 1989; Tundo and Selva, 1995, and references therein), both of which are coated with a PT catalyst in its molten state. Although, strictly, this is a gas-liquid-solid triphase system, it has traditionally been referred to as GLPTC. Advantages of GLPTC include ease of adaptation to continuous flow operation (with the gaseous reagents flowing continuously over the solid bed), absence of organic solvent since the organic substrate is present in gaseous form, ease of recovery of the PT catalyst as it is directly loaded

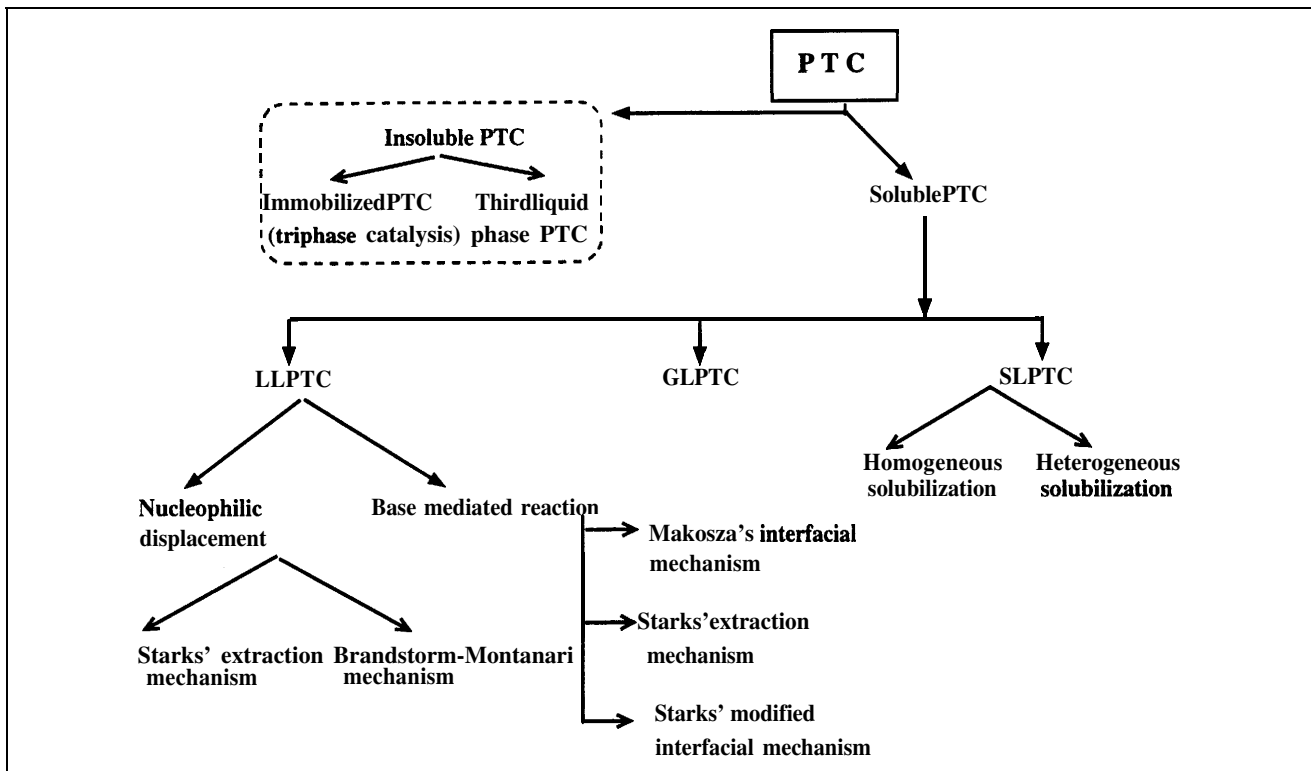

Figure 1. Classification of PTC reactions.

onto the solid bed, and better selectivity than LLPTC in some cases. A wide variety of reactions can be carried out under GLPTC conditions including a special class of reactions using dialkyl carbonates (Trotta et al., 1987; Tundo et al., 1988), typically dimethyl carbonate (DMC). In methylene activated compounds, DMC acts first as a carboxymethyl agent that allows protection of methylene active derivatives and permits nucleophilic displacement to occur with another molecule of DMC. This method of synthesis has been piloted for the synthesis of antiinflammatory drugs like ketoprofen in Belgium. Similarly, methylation of aroxylacetoneitriles and methyl-2-aroxyacetates using DMC gives up to 99% of the monomethylated derivatives, which are widely used in the synthesis of biologically active compounds and plant growth regulators (Tundo and Selva, 1995). Other reactions carried out using GLPTC include halogen exchange, esterifications, etherifications, isomerizations, alkylations, transhalogenations, Wittig and Horner reactions, and the synthesis of primary alkyl halides from primary alcohols.

However, liquid-liquid and solid-liquid systems are the main classes of reactions where PTC finds its most applications, and future discussion and analysis of PTC systems concentrates on LLPTC and SLPTC reactions.

PT catalyst

Agents used as PT catalysts are onium salts (ammonium and phosphonium salts), macrocyclic polyethers (crown ethers), aza-macrobicyclic ethers (cryptands), open chain polyethers (polyethylene glycols, PEGs, and their dimethyl ethers, glymes). Table 1 summarizes some of the properties of commonly used PT catalysts.

Quaternary onium salts (commonly called as quats) are the most widely used PT catalysts, with ammonium and phosphonium salts being industrially most feasible. A quaternary ammonium salt can also be generated *in situ* in cases where tertiary amines are used as PT agents (Hwu et al., 1992). Macrocyclic and macrobicyclic polydentate ligands like crown ethers and cryptands are widely used as PT catalysts, especially in solid-liquid systems, due to their ability to complex and solubilize metal cations, along with the corresponding anion to maintain charge balance. However, despite their high activity as effective PT catalysts, crown ethers and cryptands are not feasible for most industrial applications due to their high costs and toxicity. Open chain polyethers like polyethylene glycols (PEGs) and their many derivatives are also widely used as PT catalysts (Totten and Clinton, 1988). Although less active than quaternary ammonium salts and crown ethers, they are relatively less costly and environmentally safe. PEGs are stable, easy to recover, nontoxic and easily biodegradable, and are easily available. For reactions involving hydroxide transfer in solid-liquid systems in moderately polar organic solvents, PEGs are very good PT catalysts with activities sometimes better than those of crown ethers. Solubility in water makes them poor catalysts for liquid-liquid systems, although in some cases the PEG may form a third catalyst-rich phase and function as an active PT catalyst.

Various other novel PT catalysts have been developed which find specific applications in certain types of reactions. For example, Kondo et al. (1988, 1989, 1994, and references therein) have been developed polymeric analogs of dipolar aprotic solvents like dimethyl sulfoxide, *N,N*-dimethylformamide, *N*-methyl-2-pyrrolidone, tetramethylurea, and so on in both soluble and immobilized forms. Similarly, chiral PT

Table 1. Commonly Used PT Catalysts

Catalyst	cost	Stability and Activity	Use and Recovery of Catalyst
Ammonium salts	Cheap	Moderately stable under basic conditions and up to 100°C. Decomposition by Hofmann elimination under basic conditions. Moderately active.	Widely used. Recovery is relatively difficult.
Phosphonium salts	Costlier than ammonium salts	More stable thermally than ammonium salts, although less stable under basic conditions.	Widely used. Recovery is relatively difficult.
Crown ethers	Expensive	Stable and highly active catalysts both under basic conditions and at higher temperatures up to even 150–200°C.	Often used. Recovery is difficult and poses environmental issues due to their toxicity.
Cryptands	Expensive	Stable and highly reactive, except in the presence of strong acids.	Used sometimes despite high costs and toxicity, due to higher reactivity.
PEG	Very cheap	More stable than quaternary ammonium salts, but lower activity.	Often used. Can be used when larger quantities of catalyst cause no problems. Relatively easy to recover.

catalysts based on optically active amines like ephedrine, cinchonine, or other cinchona alkaloids are widely used (Bhattacharya et al., 1986). TDA-1 (tris(3,6-dioxahelptyl) amine), synthesized by Rhone-Poulenc, is a stable and effective PT catalyst for solid-liquid reactions, stable both under strongly basic conditions, and at high temperatures (Lavelle, 1986). Brunelle (1987) reported the use of a novel high-temperature PT catalyst, EtHexDMAP (*N*-alkyl salt of 4-dialkylamino-pyridine) for polymers and monomer synthesis. Idoux and Gupton (1987) report the use of polymer bound PT catalysts with more than one PTC site on the polymer. Similar multi-site PT catalysts can also be synthesized in their soluble non-polymeric forms from simple polyhalo substrates. Balakrishnan and Jayachandran (1995) recently reported the use of a new multisite diammonium dichloride as a PT catalyst in the addition of dichloro-carbene to styrene. Advantages of a multisite catalyst include higher catalytic activity per gram of catalyst used, milder conditions, and less contamination of product. Shaffer and Kramer (1990) report a special combination of PTC with inverse PTC (Section on PTC in the Industry) for polymerization reactions called bimolecular PTC where an ammonium salt was used to mediate transfer from the aqueous phase to the organic phase while a cyclic or an acyclic sulfide like tetrahydrothiophene served as an independent catalysts for the organic to aqueous phase transfer.

Choice of PT catalyst

Two basic requirements of a PT catalyst (Starks and Liotta, 1978) are:

1. The PT agent must be cationic and must have enough organic structure to be able to partition the nucleophilic anion into the organic phase.

2. The cation-anion bonding should be loose enough to ensure high anionic reactivity.

Factors relevant in choosing a PT catalyst are stability under reaction conditions, ease of preparation or availability of catalyst, ease of separation or recovery, activity and toxicity. Although no definite guidelines can be given to select the best catalyst for a given reaction system, analysis based on some of these factors can provide a suitable methodology to

screen different PT catalysts for a given system. We compare here crown ethers and cryptands, quaternary onium salts, and PEGs in terms of costs, toxicity, and stability with respect to temperature and basic conditions.

PEGs are the cheapest while crown ethers and cryptands are the most expensive of the commonly used PT catalysts. Crown ethers and cryptands, besides their high costs, are also toxic, and are to be avoided whenever possible (if sufficient reactivity is possible using a quat or PEG). Quaternary ammonium salts are usually useful in neutral or acidic media up to 100–150°C. Dequaternization of the quaternary onium salt by the reverse Menshutkin reaction occurs at elevated temperatures in nonbasic media. PEGs, crown ethers, and cryptands are more stable at higher temperatures and can be used up to temperatures of 150–200°C. However, it should be noted that many applications of PTC require temperatures of 50–120°C and quaternary onium salts are highly active, stable, and widely applicable under these conditions. Crown ether, cryptands, and PEGs also show higher stability to basic conditions than quaternary onium salts. In the presence of bases like 50% NaOH, quaternary ammonium salts decompose by Hofmann elimination, yielding the corresponding trialkyl amine and an alkene (Zerda et al., 1986). Also, in the presence of soft nucleophiles like RS^- , R_3C^- , R_2N^- , RO^- , nucleophilic SN_2 displacement on the quat cation is possible, liberating trialkyl amine as the leaving group and alkylating the nucleophile (Dou et al., 1977). PEGs are good alternatives to onium salts as cheap and stable PT catalysts in reactions in basic media and at elevated temperatures. However, in comparison to crown ethers, cryptands, and onium salts, larger quantities of PEG are required due to their lower activity, though recovery via distillation is easily accomplished (Totten and Clinton, 1988).

In summary, in terms of activity, stability, widespread availability and applicability, and costs, quaternary onium salts, (generally represented as Q^+X^-), are the most cost-effective and feasible PT catalysts and are often the catalysts of choice in industrial applications. PEGs have great potential but suffer from lower applicability due to their lower activity. Crown ethers and cryptands can be used when both onium salts and PEGs are not useful, but their toxicity and higher costs are usually a deterrent to industrial applications.

Within the context of quaternary onium salts, which are the catalysts of choice in many reaction systems, the exact choice of the catalyst depends on the system under consideration. In general, it is usually recommended that a variety of both ammonium and phosphonium salts be screened for a given reaction system. However, some generalized observations can be made from various studies. Usually, a highly lipophilic cation (Q^+) is used to ensure high compatibility with the organic phase and efficient anion transfer. In general, asymmetric quats like cetyltrimethylammonium halide are found to be more active than symmetric quats like tetraalkylammonium salts due to the lipophilicity imparted by the long chain alkyl (cetyl) group. However, in the case of solid-liquid systems, where the quat has to approach the solid surface to pick up the reactive anion, symmetric quats perform better than asymmetric ones. In either case, the catalyst must be cationic with sufficient organic structure (large alkyl groups) so that the cation-anion pair is substantially partitioned into the organic phase. Thus, tetramethyl ammonium chloride which is soluble more in water than in the organic phase is not a good PT agent, whereas tetrabutyl ammonium bromide has a high partition coefficient in the organic phase due to its higher lipophilic nature and is an effective and widely used PT catalyst. Besides the structure of the quat cation, the choice of the anion X^- associated with the quaternary cation is also crucial since decreasing catalyst activity is observed with increasing tendency of X^- to associate with the quaternary cation. Phosphonium salts, which are slightly more expensive than their ammonium analogs, are stable only under very mild conditions ($\leq 25^\circ\text{C}$, $\leq 15\%$ NaOH, and high concentrations of NaY) (Landini et al., 1986). Some other aspects like the choice of anion, cation structure, solvent, and so on which influence the choice of the catalyst are discussed in the Section on Mechanisms of PTC.

It should be noted that, since quaternary onium salts are the most widely used PT catalysts, we use terminology specific to the use of quats as PT catalyst, like the use of Q^+X^- to represent the PT catalyst and Q^+Y^- to represent the active form of the catalyst in all our analysis of the mechanism and modeling of PTC. However, the mechanisms discussed and modeling equations developed are applicable to crown ethers, cryptands, and PEGs also, with Q^+ representing the cationic complex formed between the crownether/cryptand/PEG and the metal cation (M^+).

Factors Affecting the PTC Cycle

Besides the factors governing the choice of the catalyst that were discussed earlier, various other factors affect the reactivity of a PT catalyzed reaction. These include choice of organic solvent and anion, catalyst structural factors that determine the distribution of anion between the organic and aqueous phases, degree of hydration of anions, and so on (Landini et al., 1978; Herriot and Picker, 1975). These are reviewed in detail by Starks et al. (1994) and Dehmlow and Dehmlow (1993), and are only briefly discussed here. Since the PTC cycle is a multistep process, factors affecting each step and inter-relationships between steps are important. It is necessary to understand the factors that cause one anion to be taken into the organic phase by Q^+ more or less readily than a second anion. Also, once transferred, the anion should

be in an active form in the organic phase. It has been suggested that the quat cation Q^+ serves to activate the anions, that is, the PT catalyst serves not only to transfer but also to activate the transferred anion Y^- by anion activation. Anion activation is related to the observed decrease of cation-anion interaction energy in going from M^+Y^- to Q^+Y^- , thereby lowering the free energy of activation for the displacement reaction. Thus, electrostatic interactions and mass transport govern most of the thermodynamics and kinetics of the PTC cycle.

Thus, anion transfer and anion activation are the important steps involved in transferring anions from the aqueous or solid phase to the organic phase in a reactive form. The anion transfer step includes a number of equilibrium steps, and the main reaction of the transferred reagent with the organic substrate takes place in the organic phase. In principle, diffusional resistance (during transfer of reactant and catalyst from one phase to the other) may be involved. Initial reports suggested that the reaction mixture requires efficient stirring for efficient mass transfer but beyond a minimum stirring rate ($\approx 200 - 300$ rpm) required for good phase contact; the rate of reaction is independent of agitation and the surface area of the interface (Starks and Owens, 1973; Herriot and Picker, 1975). However, it has been shown since that reaction rates can increase with increased agitation in cases where the rate of interphase anion transfer is slower than the organic reaction, as is often the case in solid-liquid systems and in reactions occurring in the presence of a base like NaOH or K_2CO_3 .

Factors affecting the Y^- extraction into the organic phase include cation-anion interaction energies (and hence choice of both quat cation and anion), the concentration cX^- (added salt) in the aqueous phase, ion-pair hydration, the organic structure of the PT catalyst cation, the anion associated with the catalyst cation, and the polarity of the organic phase. Solvation of the anions increases the size of the ions, decreases their mobility and diffusion coefficient, and reduces the reactivity of the ion as the reagent and solvent molecules compete for the vacant site on the ion. In polar solvents hydrogen bonds play an important role in anion solvation. In general, weakly hydrated (large ionic radius) anions and anions with sufficient organic structure are partitioned into the organic phase readily. Hard ions (those with charge density) are usually difficult to transfer, but may react rapidly once transferred. Such reactions are limited by the rate of anion transfer. A soft anion (low charge density) is easily transferred into the organic phase but needs significant energy of activation to react with the organic substrate, thereby bestowing the controlling role on the organic reaction. Hydration levels of ions decrease with increased inorganic salt and base concentrations in the aqueous phase. Aqueous salt and/or aqueous base concentrations affect not only the selectivities of the anions but also the reactivity of the transferred anion (Landini et al., 1985). Usually, best PTC conditions are obtained when the aqueous phase is saturated with the inorganic salt. The polarity of the organic solvent affects not only the solubility, anion solvation, aggregation state, and hence, the partition coefficient of the quat, but also the inherent reactivity for the organic reaction. Stabilization and solvation of the anion in the organic phase are governed by the polarity of the solvent. However, it can be assumed that for all

practical purposes the quat exists as an ion-pair and not as free ions in the organic phase. In solid-liquid systems, where the restriction of immiscibility with water is relaxed, polar solvents like acetonitrile can be used to give high reaction rates. Another attractive option is to use the organic substrate as the organic phase. Besides giving higher conversions due to higher concentrations of the reactant (pure), solvent recovery steps are eliminated leading to huge reductions in process costs (Bram and Sansoulet, 1985, and references therein).

For a quat to be an efficient PT catalyst, it is necessary that the extraction coefficient of Y^- be higher than that of X^- (Gordon and Kutina, 1977). Bar et al. (1984) have theoretically derived conditions for which a foreign counterion Z^- associated with the phase-transfer catalyst can poison the reaction between RX and MY . Similarly, experimental results have shown that catalysts in the iodide form are poor PT catalysts, since they lead to catalyst poisoning due to the tendency of the quaternary salt to associate strongly with iodide ion, whereby transfer of the nucleophilic anion is not initiated (Gordon and Kutina, 1977). Similarly, Sasson and Zahalka (1983) reported catalyst poisoning effects in the PT catalyzed esterification of alkyl chlorides by hydrophiliformate ion, with the poisoning effect reduced by the use of highly concentrated formate solutions. This phenomenon (catalyst poisoning) can only be solved by using large excesses of Y^- (Landini et al., 1974), or by replacing the aqueous phase with fresh Y^- batches several times. The use of a saturated aqueous phase of the attacking hydrophilic nucleophile, which precipitates the salt of the leaving group, also provides a simple solution to catalyst poisoning (Sasson and Zahalka, 1983).

Mechanisms of PTC

PTC under neutral conditions

A large number of PT catalyzed reactions involving simple displacement reactions are carried out under neutral conditions, although some variants of the typical PTC mechanism are possible. In the general case, the role of the PT catalyst (Q^+X^-) is to function as a vehicle to transfer the anion (Y^-) of the metal salt (M^+Y^-) from the aqueous or solid phase into the organic phase where it reacts with the organic substrate RX , giving the desired product RY and regenerating Q^+X^- , which can continue the PTC cycle.

Liquid-Liquid PTC. For a typical LLPTC cycle involving a nucleophilic substitution reaction under neutral conditions, Figure 2a shows the PTC cycle for cases where the PTC is partitioned between the organic and aqueous phases. Starks' extraction mechanism for a nucleophilic substitution reaction suggests that the quaternary salt must dissolve in the aqueous phase in order to pick up the nucleophile from the aqueous phase and then ferry the Q^+Y^- into the organic phase where reaction occurs. Here, the ion-exchange step between the PTC and the nucleophile occurs in the aqueous phase bulk, followed by transfer of the PTC-reactive anion pair into the organic phase, where reaction ensues. However, according to another parallel mechanism, the Brandstorm-Montanari mechanism (Figure 2b), dissolution of the quat in the aqueous phase is not necessary. The quaternary salt could be too lipophilic to dissolve in the aqueous phase and yet function as a good PT catalyst. In this case, the PT catalyst resides

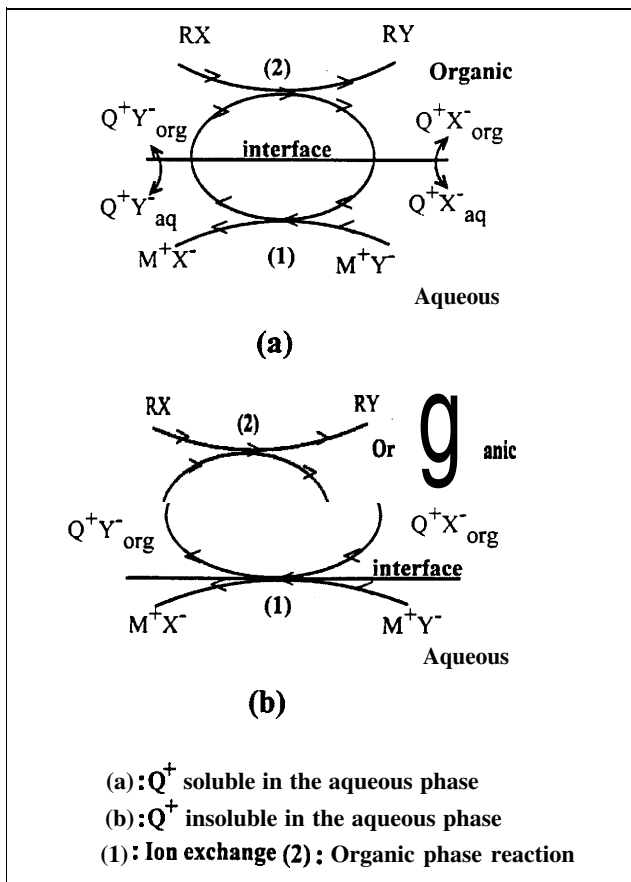

Figure 2. Mechanism of LLPTC.

exclusively in the organic phase and anion exchange occurs at or near the interface. It is not possible to distinguish between the two mechanisms by kinetic determinations alone, but the use of liquid membranes (Landini et al., 1977) or indicators (Brandstorm, 1977) shows that ion exchange at the interface for Q^+ insoluble in the aqueous phase is possible.

Solid-Liquid PTC. Despite the many applications in organic synthesis of SLPTC, only a few studies have reported the mechanism and kinetics of the SLPTC cycle. In carrying out a substitution reaction in a solid-liquid system, the quat (Q^+X^-) approaches the solid surface and undergoes ion exchange with the solid nucleophilic salt at or near the solid interface (or in some cases within the solid) to form Q^+Y^- , followed by reaction of Q^+Y^- with the organic substrate RX . The organic reaction takes place in the liquid (organic) phase only. Depending on the location and mechanism of the ion-exchange reaction and on the solubility of the solid in the organic phase, two general mechanisms for SLPTC have been proposed, namely the homogeneous and heterogeneous solubilization mechanisms (Melville and Goddard, 1988; Naik and Doraiswamy, 1997), shown in Figure 3. A more complicated ternary complex adsorption mechanism proposed recently (Yufit, 1995) needs to be further investigated.

Homogeneous solubilization requires that the nucleophilic solid have some finite solubility (though low) in the organic phase and involves the dissolution of the inorganic salt in the organic phase, followed by ion exchange of the quat in the liquid phase with dissolved MY . The PT catalyst does not

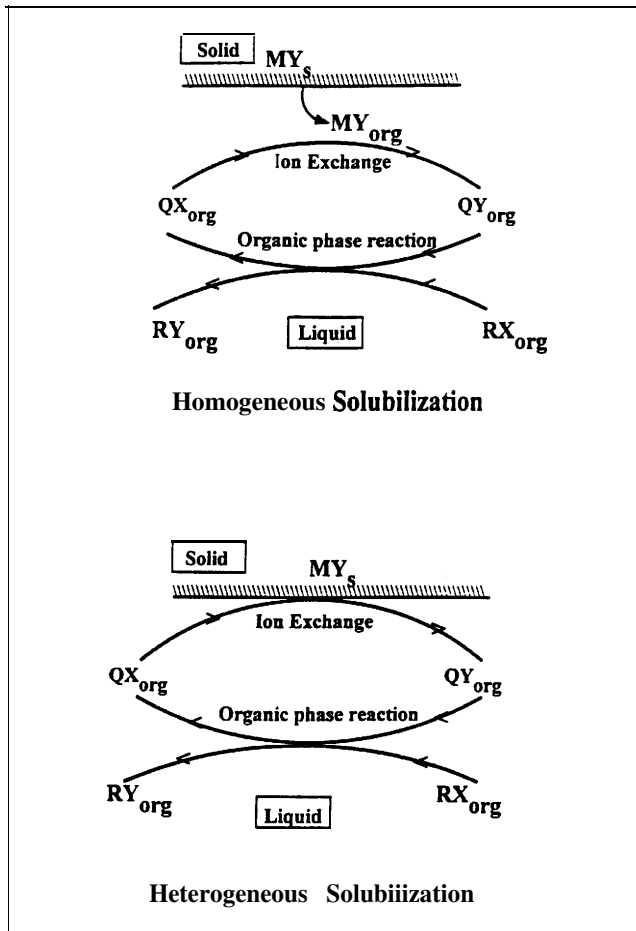

Figure 3. Mechanism of SLPTC.

interact with the solid surface directly but exchanges the anion with M^+Y^- dissolved in the organic phase, and then ferries the Y^- into the organic bulk in the form of Q^+Y^- . Although this mechanism alone cannot account for the large enhancements observed in the presence of catalytic amounts of PT agents, it cannot be ruled out completely, especially in cases where the nucleophilic salt has a finite solubility in the organic phase and in cases where the PT catalyst cannot approach the solid surface easily and instead combines with dissolved MY to form Q^+Y^- . Heterogeneous solubilization occurs by the transfer of the nucleophilic anion by a PT catalyst from the surface of the solid crystalline lattice to the organic phase. The quat reacts with the solid at its surface (or, in some cases, within the solid), pairs with the nucleophilic anion Y^- , and ferries it into the organic bulk in the form of Q^+Y^- . This is followed by the organic reaction between Q^+Y^- and RX in the liquid phase.

Esikova and Yufit (1991a,b) report a new mechanism for SLPTC, via the formation of adsorption complexes. This involves a series of adsorption steps at the solid reagent (KCl in their case) surface, giving intermediate adsorption complexes like $MY \cdot RX_{ads}$, $MY \cdot QX_{ads}$, $RX \cdot QX$, $MY \cdot QX \cdot RX_{ads}$, with possible intermediate rearrangement through six-center cyclic transition states. A number of complex kinetic equations are obtained based on different schemes for varying sequences of reagent adsorption, intermediate lifetimes, and

adsorption constant values. Thus, according to this theory, intermediate adsorption complexes are crucial to the SLPTC cycle. Ion exchange is not considered to be one of the steps preceding the organic-phase reaction, since in their reaction system analysis showed that solid KCl cannot ion exchange with QBr . They report a correlation between free substitution energy and energy of the crystalline lattice. The cation in M^+Y^- also affects the reaction rate, indicating that the solid salt participates directly in the rate determining step. The article raises some crucial issues in SLPTC which have been ignored before, such as the importance of the solid during reaction, influence of the salt product on solid-phase properties significance of crystalline lattice energy, and so on. With a high solid reagent/organic substrate ratio (as is common), the influence of the product would be minimal as the solid-phase composition does not change much. However, in some cases, it might be important to consider the change in the solid-phase composition with reaction. Esikova and Yufit (1991a) explain the product hindrance as being due to the binding of the quat species Q^+X^- with the product M^+X^- leading to *unproductive binding*. On the other hand, adsorption complexes of Q^+X^- with M^+X^- lead to active catalysis or *productive binding*.

Another important aspect in solid-liquid systems is the role of water and its effect on the mechanism and kinetics of the SLPTC cycle. Different theories have been proposed to explain the role of water in SLPTC systems. Liotta et al. (1987) and Zahalka and Sasson (1989) reported a maximum in reaction rate for SLPTC systems with increasing amounts of water in the system. On the other hand, Zubrick et al. (1975) reported no effect of water, while Yadav and Sharma (1981) observed a decrease in conversion in the presence of traces of water. The omega-phase theory (Liotta et al., 1987) proposes that traces of water enhance the rate of the PTC cycle due to solid dissolution in a thin aqueous film (called the omega phase) formed around the solid surface. Only minute quantities of the PT catalyst are present in the organic phase ($< 3\%$) with most of the crown ether translocated onto the surface of the inorganic nucleophilic salt. Trace quantities of water facilitate the interaction between the crown and the salt by breaking down the crystal lattice structure, and enhance the ion-exchange reaction. The complexation of the crown in the organic phase with the solid nucleophilic salt was postulated to be the rate controlling step in the absence of water, whereas the organic reaction with pseudo-first-order kinetics becomes the controlling step in the presence of water. Thus, pseudo-zero-order reaction rate profiles were obtained in the absence of water, while a pseudo-first-order reaction rate profile was obtained in the presence of water traces. A similar thin aqueous boundary layer theory has been proposed by Arrad and Sasson (1988) to explain the role of water traces in SLPTC. However, it should be noted that addition of excess water leads to lower reactivity due to increased hydration of anions.

PTC in the presence of bases

A large number of industrially important reactions involve the use of PTC in the presence of a base, usually aqueous $NaOH$ or solid K_2CO_3 . These include C-, N-, O- and S-alkylations, isomerizations, *H/D* exchanges, additions, β - and

a-eliminations, hydrolysis reactions, and so on. C-, O-, and N-alkylations find wide applications in a variety of reactions useful in the pharmaceutical and agro-chemical industries. PT catalyzed alkylations of weak acids like aliphatic alcohols ($pK_a \sim 18$) and very weak CH- and NH-acids ($pK_a \sim 22-25$) are possible in the presence of concentrated (50%) aqueous NaOH or solid K_2CO_3 . An advantage of carrying out reactions in the presence of a base in biphasic systems is that it prevents hydrolysis of the organic reactant, since OH^- has limited solubility in the organic phase, whereby the organic substrate is not subject to the alkaline conditions present in the aqueous phase. The use of a PT catalyst also obviates the need for expensive and corrosive reducing agents like sodium azide and sodium hydride.

Despite wide-scale applications of PTC reactions in the presence of a base, the mechanism of these reactions is not clear. PTC systems operate via different mechanisms in the presence of bases (Makosza, 1977). However, it is an established fact that in most cases it does not involve the transfer of OH^- by the quat as a Q^+OH^- complex, since Q^+OH^- is highly hydrophilic and has very limited solubility in the organic phase. Alkylation reactions that have been proposed to be mediated through a Q^+OH^- intermediate probably involve reaction between Q^+OH^- and the organic substrate at the liquid-liquid interface. Rabinovitz et al. (1986) review the effect of anions, base concentration, and water in PTC/ OH^- systems.

Makosza's interfacial mechanism (Makosza, 1975), based on substrate deprotonation by the base, is the most widely accepted mechanism. It has been experimentally validated for alkylation reactions using PTC/ OH^- (Solaro et al., 1980; Balakrishnan et al., 1993). Also, carbene reactions follow a different mechanism. The interfacial mechanism involves deprotonation of the organic substrate (ROH) at the interface by the hydroxide ion (present in the aqueous phase), forming Na^+OR^- at the interface. Na^+OR^- is essentially insoluble in either phase (Makosza and Bialecka, 1977) and is immobilized at the interface. The PT catalyst functions to draw the organic anion into the bulk organic phase as a Q^+OR^- ion pair, liberating Na^+X^- into the aqueous phase. Q^+OR^- then reacts with the organic substrate $R'Y$ to form $R'-OR$.

Gas-liquid PTC

The mechanism of GLPTC differs from traditional PTC mechanisms in liquid-liquid and solid-liquid systems. No one mechanism has been proposed for GLPTC because of the different types of reaction involved. However, it is clear that the gaseous reactant has to diffuse through the molten liquid film of the PT catalyst, with reaction occurring simultaneously between the diffusing species and the catalyst. The exact mechanism of transfer of the solid reagent into the catalyst phase and reaction with the gaseous reagent is not understood well, especially when the solid reagent is a base like K_2CO_3 , with the organic and nucleophilic reagents present in the gaseous phase. For example, in the PEG catalyzed isomerization of allylbenzene, Neumann and Sasson (1985a) suggest the formation of a PEG- K_2CO_3 complex that adsorbs the organic substrate, followed by reaction at the catalyst interface.

When the molten thermally stable PT catalyst is supported on an inert matrix, the solid phase functions strictly as a sup-

port for the catalyst. Separation of the catalyst from the reaction mixture is easier in this case. Reaction is diffusion controlled and excess catalyst does not affect the conversion above a certain value due to congestion of pores and reduction of surface area. Diffusional limitations prevent the reagents from reaching the catalyst bound deep within the zeolite pores in the limited contact time between the solid phase and the gaseous reactants (Angeletti et al., 1984).

Modeling of PTC Reactions

General considerations in PTC modeling

In modeling heterogeneous reactions, the interactions of diffusion with chemical reaction become important when the relative rates of reaction and diffusion are of the same order of magnitude. For example, PTC has been found to enhance not only slow reactions (kinetic regime) but also fast reactions, where reaction occurs partially or entirely in the diffusion film. In fast reactions, diffusion and chemical reaction occur simultaneously and reaction may occur partly or completely in the organic film. Thus, in general, in modeling PTC systems, it is necessary to consider the individual steps that comprise the PTC cycle, namely interphase mass transfer, ion exchange, and the main organic phase reaction. The rate of the overall process depends on the relative rates of the individual steps. Although a large number of articles have been published on the synthetic applications of PTC in the last three decades, only a handful of these report any engineering analysis of the complex PTC cycle. Melville and Goddard (1990) stress the importance of convection, diffusion, and reaction in a PTC system by defining important dimensionless parameters like the Damköhler number (Da) and the Peclet number (Pe) that characterize the relative importance of diffusion vs. reaction and convection vs. diffusion, respectively, in a PTC system. Interphase transport of species across the interface from one well-mixed bulk phase to another is conveniently quantified by defining an overall mass-transfer coefficient, which is a combination of the individual local mass-transfer coefficients defined for each phase, with no mass-transfer resistance assumed at the interface itself. The compositions on either side of the interface can be related by equilibrium constants or partition coefficients, which are often assumed to be independent of phase composition in most modeling studies. However, in most kinetic and modeling studies, the kinetics of ion exchange, quat partitioning equilibria, and interphase mass-transfer steps are ignored and the organic reaction is assumed to be the rate controlling step, giving

$$-r_{RX} = k_{obs} C_{RX_{org}} = k_2 C_{QY_{org}} C_{RX_{org}} \quad (1)$$

where the pseudo-first-order constant k_{obs} (1/s) is a linear function of the active catalyst concentration $C_{QY_{org}}$. We should point out at this stage that in most of the modeling in this article, rates have been written in terms of the rate of change of concentration of species with time, which is strictly valid only for batch systems. Since most PTC systems are traditionally run in batch systems, such an analysis is most helpful. However, in case these models are to be adapted to continuous systems, the design equations for a continuous reactor would use a similar analysis with $-r_A$ representing the rate of disappearance of reagent A.

The active catalyst concentration $C_{QY_{org}}$ is important in determining the rate of the PTC cycle, since it governs the rate of the organic reaction. Under the assumptions of large excess of nucleophilic reagent and rapid ion exchange, it has been proved that the concentration of QY in the organic phase is constant during reaction. While it is true in many liquid-liquid systems that ion exchange is much faster (8-12 times, Wang and Yang, 1990) than the organic reaction, it is not true that ion exchange is always in equilibrium. In addition, $C_{QY_{org}}$ depends not only on the kinetics of the ion-exchange reaction but also on the rates of interphase mass transfer and the equilibria governing the partitioning of quat species between phases. Thus, in the general case, the concentration of QY can vary with time. For example, for LLPTC, Wu (1993) showed that the assumption of constant QY is not valid even for slow reactions, even when a pseudo-first-order fit was possible to the experimental data. For mass-transfer controlled reactions, the concentration of QY fluctuates to a greater extent during reaction and a pseudo-first-order hypothesis is not valid in this case. Experimental data on QY concentration profiles with time (Wang and Yang, 1990, 1991a) validate these model predictions. Bhattacharya (1996) has proposed that a quasi-stationary concentration of quat species in the organic phase arises only when the rate of delivery of the nucleophile to the organic phase is almost exactly balanced by its consumption in the organic reaction. When the rate of consumption is faster than the rate of quat transport, the concentration in the organic phase falls. It is also possible that QY accumulates in the organic phase, depending on the relative rates of interphase mass transfer, reaction, and partition coefficient of quat species. Wang and Wu (1991) developed a comprehensive model for LLPTC in a sequential reaction. Although their experimental data were consistent with a first-order reaction rate, they found that the pseudo-first-order reaction rate constant was not linearly related to the concentration of the PT catalyst. They then went on to develop a complicated mathematical expression for the apparent first-order rate constant in terms of the rate constants for the ion-exchange and organic reactions, the distribution coefficients for QY and QX, the Thiele modulus for QY, the dissociation constant of QY in the aqueous phase, the volume of the aqueous and organic phases, and the amount of quat added. Similarly, Wang and Yang (1990) obtained experimental data for the concentration of QY over time for the synthesis of 2,4,6-tribromophenol allyl ether. Their results show that the QY concentration is constant over time only for particular values of the nucleophile-to-organic substrate and nucleophile-to-added quat mole ratios. Thus, in the general case, the concentration of QY slowly builds up over time and then can vary (decrease or increase) or remain constant, depending on the particular system parameters and species concentrations. Similarly, for solid-liquid systems, Naik and Doraiswamy (1997) have shown that the concentration of QY varies with time if steps other than the organic reaction, like ion exchange, solid dissolution, or quat transport, contribute to the overall reaction rate (see Figure 10b).

Regimes of reaction

Thus, in modeling PTC systems, it is important to consider the important role of interphase mass transfer and its effect

on the kinetics of the overall cycle. Before considering the detailed modeling of PTC reactions, we adapt the theory of mass transfer with chemical reaction (Doraiswamy and Sharma, 1984) to PTC systems to analyze the effects of mass transfer on the organic reaction. We assume here that the aqueous side resistance is negligible and ion-exchange reaction is fast (valid assumptions in many liquid-liquid systems), and classify the reactions into four main reaction regimes based on the relative rates of organic reaction and mass transfer. As presented here, the analysis is restricted to transport of QY from the interface into the organic liquid and reaction of QY with the organic substrate RX. Further adaptation to include the ion-exchange kinetics and the effects of aqueous/solid phase mass-transfer limitations (that is, to account for the resistance to transport of QY from the aqueous/solid phase, where it is formed, to the interface) can be made. However, the purpose here is to merely illustrate the classification of reaction regimes and stress the importance of mass transfer in PTC systems.

The four main regimes of reaction are summarized in Table 2 and shown in Figure 4. Regime 1 corresponds to pure kinetic control, where mass-transfer steps are very fast and the rate of reaction is dictated by the kinetics of the organic reaction. Since mass-transfer steps are fast, there is no gradient of QY across the film and all reaction takes place in the organic bulk. Regime 2 (slow reaction) involves the instant consumption of all the Q^+Y^- as soon as it reaches the bulk, since mass transfer is relatively slow as compared to the reaction in the bulk. However, the reaction is still not fast enough to cause the reaction within the organic liquid film at the interface, as is the case in regimes between 2 and 3, and 3 and 4. In regime 3, reaction is so fast that all the reaction takes place in the film, while between regimes 2 and 3 some reaction occurs within the film and the rest in the bulk organic phase. In regime 4 the reaction occurs so fast that QY and RX cannot coexist locally but meet at a reaction plane within the boundary layer, where they react instantaneously. The rate of reaction depends on the rate at which Q^+Y^- is transported from the interface to the reaction plane and the rate at which RX is transported from the organic bulk to the reaction plane. Relative magnitudes of molecular diffusivities of the reacting species decide the location of this reaction plane at $z = \xi$

$$\xi = \delta \left[1 + \frac{D_{RX}C_{RX_{org}}}{D_{QY}C_{QY_{org}}} \right]_{z=0}^{-1} \quad (2)$$

For typical PTC applications, since the concentration of RX is higher than the quat concentrations, the reaction plane is very near the interface ($z = 0$) (Evans and Palmer, 1981). It should also be noted that the concentrations at the boundaries ($z = 0$ and $z = \delta$) are time-dependent because of accumulation and depletion of species in the bulk phases.

In general, the organic reaction can take place within the organic film at the interface or in the organic bulk. In most cases, reaction takes place entirely in the organic bulk, since the rate of reaction is slow (regimes 1 and 2), and hence the need for a PT catalyst. However, a PT catalyst can be effective even for relatively fast reactions (Melville and Yortos, 1986; Lele et al., 1983). In such cases, the rate of reaction is

Table 2. Regimes of PT Catalyzed Reaction

Regime	Conditions Satisfied	Rate of Reaction
Very slow reaction (R1)	Organic reaction controlling $* \gg, ** \sqrt{M} \ll 1$ $C_{QY_{org}} = C_{QY_{int}}$	$k_{mn} C_{QY_{org}}^m C_{RX_{org}}^n$
Slow reaction (R2)	Mass transport of QY controlling $* \ll, ** \sqrt{M} \ll 1$ $C_{QY_{org}} = 0$	$k_{lQY} a C_{QY_{int}}$
Between regimes 1 and 2 (R1-2)	Neither controlling $* \approx, ** \sqrt{M} \ll 1$ $C_{QY_{org}} \neq C_{QY_{int}}$	$k_{lQY} a [C_{QY_{int}} - C_{QY_{org}}]$
Fast reaction (R3)	$* \ll **$ $\sqrt{M} \gg 1$	$k_{lQY} \sqrt{M} C_{QY_{int}}$
Instantaneous reaction (R4)	$\sqrt{M} \gg 1$ $\sqrt{M} \gg C_{RX} / C_{QY_{int}} \sqrt{D_{RX} / D_{QY}}$	$k_{lQY} C_{QY_{int}} [1 + (C_{RX} / C_{QY_{int}}) (D_{RX} / D_{QY})]$

* = Rate of mass transport of QY from interface to the organic bulk = $k_{lQY} a C_{QY_{org}}$

** = Rate of organic reaction = $k_{mn} C_{QY_{org}}^m C_{RX_{org}}^n$

\sqrt{M} = Ratio of reaction in the film to that in the bulk = $\sqrt{[(2/m + 1) D_{QY} k_{mn} C_{QY_{int}}^{m-1} C_{RX}^n] / k_{lQY}}$

much greater than the mass transport rate of $Q^+ Y^-$, and reaction starts within the diffusion film adjacent to the interface. Simultaneous diffusion and reaction occur within the

film in these reactions (regimes 3 and 4). For example, the alkaline hydrolysis of formate esters under PTC conditions is a diffusion limited fast reaction (regime 3) with reaction complete within the diffusion film even in the absence of a PT catalyst. Addition of a PT catalyst was found to shift the locale of the reaction from the aqueous phase to the organic phase and the reaction rate constant in the presence of the PT catalyst was found to be 70-140 times higher than those obtained without the PT catalyst (Asai et al., 1992).

Modeling of LLPTC Systems

Important factors in LLPTC modeling

Recently, some authors have developed mathematical mass-transfer-cum-reaction models for LLPTC (Evans and Palmer, 1981; Wang and Yang, 1991a; Chen et al., 1991; Wu, 1993). Some important features of these models are summarized in the next section. However, it should be noted that a comprehensive quantitative mathematical model for PTC, accounting for the intrinsic kinetics of ion-exchange and main organic reaction, mass conservation of species, overall mass conservation, interphase and intraphase mass transfer, catalyst loading and activity, equilibrium partitioning of catalyst, location of reaction (organic phase, aqueous or solid phase, or interface), and flow patterns for each phase, are yet to be developed.

Some of the important factors to be considered in modeling LLPTC are:

(1) *Distribution Coefficient of Quat between the Organic and Aqueous Phases.* The distribution coefficient of the quat is crucial as the concentration of the reactive anion Y^- in the organic phase depends on the partition coefficients of $Q^+ X^-$ and $Q^+ Y^-$ between the two phases. It is defined as

$$m_{QX} = \frac{C_{QX_{org}}}{C_{QX_{aq}}}, \quad m_{QY} = \frac{C_{QY_{org}}}{C_{QY_{aq}}} \quad (3)$$

The distribution coefficient is often assumed to be constant during reaction, although it has been expressed as a function

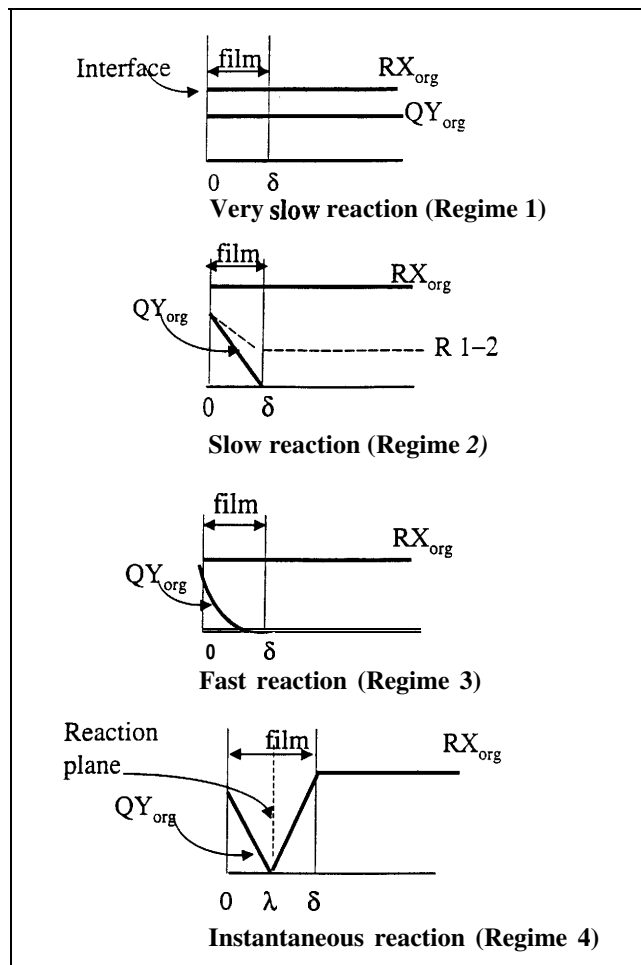

Figure 4. Regimes of reaction.

of the aqueous phase ionic strength (Asai et al., 1991, 1992) or correlated to the aqueous phase concentration of the quat species and temperature (Wang and Yang 1991a).

(2) *Dissociation Constant in Aqueous Phase.* In general, in any solvent, there can be free ions (thermodynamically distinct entities) coexisting in equilibrium with ion pairs. Often, it is assumed that the quat is completely ionized in the aqueous phase to form free ions. However, this assumption may not be valid in all cases and, in general, a dissociation constant can be defined as

$$K_{QX} = \frac{C_{QX_{aq}}}{C_{Q+aq} C_{X^{-}aq}} \quad (4)$$

The dissociation constant in aprotic organic solvents can be derived from fundamental principles (Brandstorm, 1977), based on Bjerrum's theory for ion pairs, as a function of the dielectric constant of the solvent, temperature, and the distance between the ions in the ion pair. However, in most organic media, the dissociation constant of ion pairs is very small (on the order of 10^{-4} – 10^{-5}), and hence, the free ion concentration is negligibly low.

(3) *Mass-Transfer Coefficients for QY and QX.* The PTC cycle includes intraphase and interphase mass transport steps along with reactions. Wang and Yang (1991a) measured the interphase mass-transfer coefficients of QX (or QY) by collecting concentration-time data for the species from an agitated mixture of QX (or QY) in known quantities of water and the organic solvent. The transfer of QX from the aqueous phase to the organic phase (or QY from the organic phase to the aqueous phase) can then be quantified by a differential equation, which when solved gives a simple correlation to calculate the overall mass-transfer coefficient. For example, for QY we can derive

$$\ln \left[\frac{C_{QY_{org}}}{C_{QY_{org}^0}} + m_{QY} \frac{V_o}{V_a} \left(\frac{C_{QY_{org}}}{C_{QY_{org}^0}} - 1 \right) \right] \left[\frac{1}{m_{QY}} + \frac{V_o}{V_a} \right]^{-1} = -k_{1QY} t \quad (5)$$

(4) *Intrinsic Kinetics of the Ion-Exchange Reaction.* In the general case, the intrinsic kinetics of the ion-exchange reaction can be found by carrying out the PTC reaction in the absence of the organic substrate. Having independently calculated the mass-transfer coefficient, we can calculate the intrinsic kinetics of QY generation via ion exchange by tracking the concentration of QY in the organic phase. Wang and Yang (1991a) report differential equations for the dynamics of QY in both the aqueous and organic phases in two-phase reactions with no organic substrate added. The ion-exchange reaction rate constants can then be calculated by correlating the equations with the experimental data.

(5) *Intrinsic Kinetics of the Organic Reaction.* By carrying out a homogeneous reaction in the organic phase with the organic substrate and a known quantity of QY (instead of using MY), the intrinsic rate constant of the organic reaction can be found.

Using information from items 1-5 above, the overall kinetics of the PTC cycle in a liquid-liquid system can be characterized. However, due to the complex multistep mechanism of PTC, various approaches to LLPTC modeling have been taken (Bhattacharya, 1996; Chen et al., 1991; Wu, 1993; Melville and Goddard, 1988; Evans and Palmer, 1981). However, though each of these models has its own merits, we believe that a comprehensive general model for all LLPTC reactions is yet to be developed.

LLPTC modeling: reactions under neutral conditions

We now discuss some of the main features of LLPTC models developed for reaction under neutral conditions. Evans and Palmer (1981) were among the first to consider the effect of diffusion and mass transfer in PTC. They considered PTC in liquid-liquid systems by considering two well-mixed bulk phases of uniform composition separated by a uniform stagnant mass-transfer layer at the interface, and set up equations for bulk phase species balance and mass conservation equations for simultaneous diffusion and reaction in the film. Dynamics of the interaction between reaction and diffusion were studied under these assumptions for two special cases: (a) reaction which is pseudo-first-order in the quaternary ion-pair; (b) mass-transfer controlled instantaneous reaction. It should be noted that (a) represents a variation from the normal pseudo-first-order reaction rate derived for most PTC reactions, as it assumes first-order dependence on quat concentration and not the organic substrate concentration. This is valid at short reaction times for cases with large excess of RX with the pseudo-first-order reaction rate constant depending on the RX concentration. Solution for instantaneous reaction gave the upper limit on the rate of the PTC reaction. Their analysis showed that catalyst poisoning due to low anion selectivity ratios leads to low conversions and slow rates (Figure 5), and so that an increase in film thickness can actually increase the conversion at high reaction rates ($Da = [(k_2 C_{RX_{org}} \delta^2) / D_{RY}] > 1$).

However, in a similar analysis based on the classical stagnant film model for a steady-state continuous flow membrane

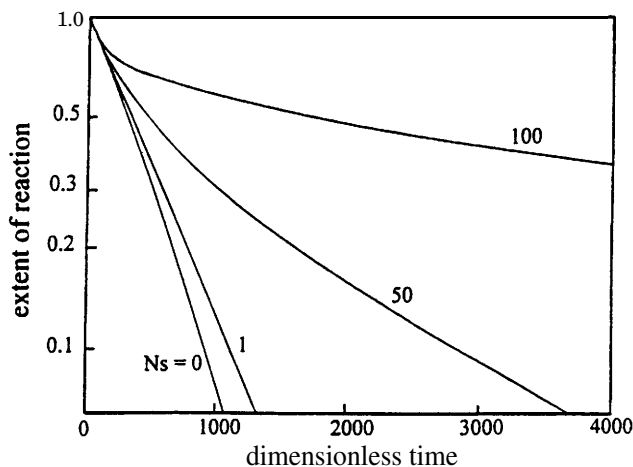

Figure 5. Effect of anion selectivity ratio on RX conversion.

Adapted from Evans and Palmer (1981).

reactor system, Stanley and Quinn (1987) reported that this intriguing benefit of the organic phase mass-transfer resistance does not really materialize and that catalytic effectiveness decreases when the film thickness increases. Thus, though conversion in the membrane reactor increased with membrane thickness because a thicker membrane gave higher active reactor volume, the effectiveness factor decreased with increasing mass-transfer resistance due to the thicker membranes (Figure 6). It should be noted that in this case the hydrophobic membrane used was assumed to be free of any diffusional limitations (large pores compared to dimensions of diffusing reactants) with no selectivity toward any of the species. Thus, under these conditions, the membrane merely stabilizes the interface and is effectively a stagnant region of organic liquid. The authors developed an exact analysis of intramembrane diffusion and reaction similar to Evans and Palmer's (1981), and studied the effect of Damkohler number, organic reaction equilibrium rate constant, reactant feed-rate ratio, flow rate of the organic phase, and the organic reaction reactivity on conversion. Assuming cocurrent plug flow in the channels, simple one-dimensional convection/reaction flow channel mass balances and membrane mass balances were set up. Ion-exchange equilibrium was assumed at the organic/aqueous interface (on the aqueous side of the membrane). The reader is referred to the original article for details of the complicated set of equations and a discussion of the solutions.

Various other ways of characterizing the role of mass transfer in PTC systems have been reported. For example, based on the two-film theory, Chen et al. (1991) derived algebraic expressions for the interphase flux of QY and QX. Nonlinear differential equations described the slow reaction in the organic phase, and coupled algebraic equations described the dissociation equilibria in the aqueous phase and the species mass balance. Model parameters were estimated

from experimental data using a two-stage optimal parameter estimation scheme. Wu (1993) used a two film theory to consider mass transfer of catalyst between two liquid phases and characterized the transfer of Q^+X^- from the organic phase to the aqueous phase and of Q^+Y^- from the aqueous to the organic phase by defining

$$\psi_{QY} = \frac{C_{QY_a}V_a}{C_{QY_o}V_o}m_{QY}, \quad \psi_{QX} = \frac{C_{QY_o}V_o}{C_{QY_a}V_a}m_{QX} \quad (6)$$

If PTC in both phases is in extractive equilibrium and mass-transfer resistances are neglected completely, then ψ_{QY} and ψ_{QX} are each equal to 1. Assuming extractive equilibrium and complete dissociation of MY and MX in the aqueous phase, Wu (1993) derived a set of balance equations that were solved by eliminating the time variable (phase plane modeling). The relevant rate equations are

$$-\frac{dC_{RX_o}}{dt} = k_2C_{RX_o}C_{QY_o} \quad (7)$$

$$-\frac{dC_{QX_o}}{dt} = -k_2C_{RX_o}C_{QY_o} + k_{1QX}a(C_{QX_o} - m_{QX}C_{QX_a}) \quad (8)$$

$$-\frac{dC_{QY_o}}{dt} = k_2C_{RX_o}C_{QY_o} - k_{1QY}a(m_{QY}C_{QY_a} - C_{QY_o}) \quad (9)$$

$$\begin{aligned} -\frac{dC_{QX_a}}{dt} &= k_1C_{MY_a}C_{QX_a} - k_{-1}C_{MX_a}C_{QY_a} \\ &\quad - k_{1QX}a(C_{QX_o} - m_{QX}C_{QX_a}) \end{aligned} \quad (10)$$

$$\begin{aligned} -\frac{dC_{QY_a}}{dt} &= k_{1QY}a(m_{QY}C_{QY_a} - C_{QY_o}) \\ &\quad - k_1C_{MY_a}C_{QX_a} + k_{-1}C_{MX_a}C_{QY_a} \end{aligned} \quad (11)$$

Overall mass balance equations can be written for the quaternary cation, and Y^- and X^- anions.

$$q_o = V_o(C_{QY_o} + C_{QX_o}) + V_a(C_{QX_a} + C_{QY_a}) \quad (12)$$

$$N_{MY}^0 = V_o(C_{QY_o} + C_{RX_o}^0 - C_{RX_o}) + V_a(C_{Y_a} + C_{QY_a}) \quad (13)$$

$$N_{MX}^0 + V_oC_{RX_o} + q_o = V_o(C_{QX_o} + C_{RX_o}) + V_a(C_{X_a} + C_{QX_a}) \quad (14)$$

Dynamics for a slow phase-transfer reaction (pseudo-first-order kinetics) and a mass-transfer controlled instantaneous reaction were studied. Wu (1996) modified the solution for a slow reaction by not assuming pseudo-first-order kinetics but making the pseudo-steady-state assumption for catalyst species (QY and QX) in both the aqueous and the organic phases. A complicated equation was derived for the concentration of RX, assuming the concentration of the PT catalyst to be much smaller than that of the reactant Wu (1996) also derived an expression for the catalyst effectiveness, which is defined as the ratio of the actual reaction rate to that with all the catalyst present as QY, in terms of seven physically meaningful dimensionless parameters, including the Damkohler numbers that give the relative rates of the organic reaction

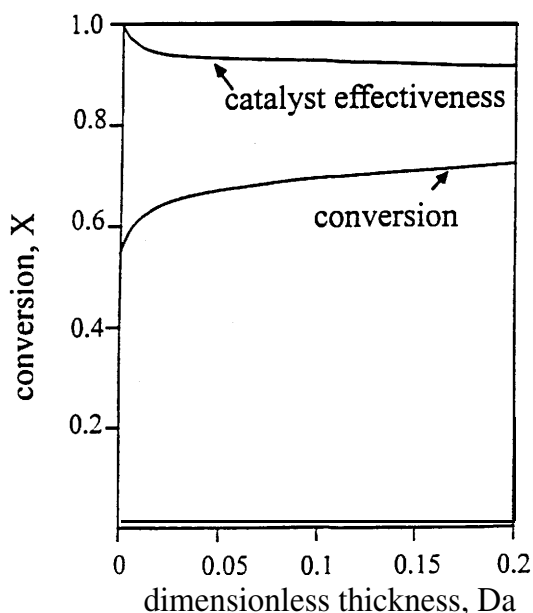

Figure 6. Effect of membrane thickness on RX conversion and catalyst effectiveness.

Adapted from Stanley and Quinn (1987).

and the mass transfer of the quat species, distribution coefficients for QY and QX, ratio of reaction rate constants for forward and backward reactions for ion exchange, and the ratio of rate constant of organic reaction to that of the forward ion-exchange reaction.

$$\eta_c = \left[\frac{V_o/V_a m_{QY} + 1}{V_o/V_a m_{QY}} + \left(\frac{Da_{QY}}{V_o/V_a m_{QY}} + Da_{QX} \right) + (1 + V_o/V_a m_{QY}) \left(\frac{Da_{QY} + 1}{V_o/V_a m_{QY}} \frac{1}{K} + \frac{k_2}{k_1} V_o/V_a \right) \right] \quad (15)$$

Asai et al. (1994) have developed a reaction model for the oxidation of benzyl alcohol using hypochlorite ion in the presence of a PT catalyst. Based on the film theory, they develop analytic expressions for the mass-transfer rate of QY across the interface and for the inter-facial concentration of QY. Recently, Bhattacharya (1996) has developed a simple and general framework for modeling PTC reactions in liquid-liquid systems. The uniqueness of this approach stems from the fact that it can model complex multistep reactions in both aqueous and organic phases, and thus could model both normal and inverse PTC reactions. The model does not resort to the commonly made pseudo-steady-state assumption, nor does it assume extractive equilibrium. This unified framework was validated with experimental data from a number of previous articles for both PTC and IPTC systems.

Models for LLPTC get even more complicated for special cases like PTC systems involving reactions in both aqueous and organic phases, or systems involving a base reaction even in the absence of PT catalyst, or other complex series-parallel multiple reaction schemes. For example, Wang and Wu (1991) studied the kinetics and mass-transfer implications for a sequential reaction using PTC that involved a complex reaction scheme with six sequential SN_2 reactions in the organic phase, along with interphase mass transfer and ion exchange in the aqueous phase. Wang and Chang (1991a,b) studied the kinetics of the allylation of phenoxide with allyl chloride in the presence of PEG as PT catalyst. In this reaction system, reaction was possible in both the aqueous and organic phases, and even in the absence of PEG. In addition, PEG catalyzed both the aqueous- and organic-phase reactions. Similarly, in the alkaline hydrolysis of *n*-butyl acetate, hydrolysis occurs in both the aqueous and organic phases simultaneously (Asai et al., 1992a).

LLPTC modeling: reactions in the presence of bases

As discussed before, the interfacial mechanism is the most widely accepted mechanism for PTC reactions in the presence of a base. However, despite numerous industrially important applications, especially in alkylation reactions, only a few articles pertaining to analysis and modeling of this class of reactions are available. Besides some papers which validate the complex mechanism and chemistry involved in these reactions, very few kinetic studies or mathematical models are reported. A detailed model incorporating the various steps involved in the PTC/OH^- reaction cycle is yet to be developed. We summarize here the results of some of the kinetic and modeling studies in PTC/OH^- systems.

Wang and Wu (1990) analyzed the effects of catalyst, solvent, $NaOH$ /organic substrate ratio, and temperature on the consecutive reaction between 2,2,2-trifluoroethanol with hexachlorocyclotriphosphazene in the presence of aqueous $NaOH$. The reaction rates were controlled by both intrinsic reaction kinetics and mass-transfer effects. Wang and Chang (1994, 1995) synthesized a mixture of two symmetric acetals and one unsymmetric acetal by reacting dibromomethane with two mixed alcohols in the presence of KOH and a PT catalyst. Based on an equilibrium model, they derived the following expression to predict the concentration of the active catalyst QOR in terms of the concentration of the various species involved in the reaction and the equilibrium parameters. Their model equations show that even without considering the effect of mass transfer, a simple equilibrium model can get very complicated due to the complex sequence of reactions, involved in the presence of a base. For example, a complex reaction-diffusion model for the aqueous and organic phase hydrolysis of *n*-butyl acetate has been developed by Asai et al. (1992). This model not only accounts for the reaction (uncatalyzed and catalyzed by a PT catalyst) in both aqueous and organic phases, but also includes the effect of interphase mass transfer of the quat species. The complex dissociation equilibria of the quat species, phase partitioning of butyl acetate and various quat species, and the dependence of solubilities, dissociation constants, and hence reaction rates on ionic strengths are all included in this complex model. Mass transfer of Q^+OH^- was found to be an important step in the overall cycle, with the observed overall rate proportional to the inter-facial Q^+OH^- concentration, which could be expressed in terms of the Q^+Cl^- concentration in the organic phase, the aqueous phase $NaOH$ concentration, and the ionic strength in the aqueous phase.

Modeling of SLPTC Systems

Despite the numerous reports on the synthesis of various important fine chemicals using SLPTC, only a few kinetic studies and fewer modeling and mathematical analyses of SLPTC have been reported. Most kinetic studies so far have assumed that the organic-phase reaction is the controlling step (Yadav and Sharma, 1981; Wong and Wai, 1983; Zahalka and Sasson, 1989), and simple pseudo-first-order reaction rates have been fit to the observed data. However, like LLPTC systems, the SLPTC cycle can be broken down into a number of steps, one or more of which might contribute to the overall rate of the cycle. For example, in the synthesis of monoglycerides of fatty acids by the reaction of epichlorohydrin and solid sodium stearate using SLPTC, kinetic analysis showed that a pseudo-first-order reaction rate did not fit the experimental data (Aserin et al., 1984). A value of activation energy of less than 10 kcal/mol indicated that solid-liquid mass transfer was important and the transfer of the stearate anion to the organic phase could be the rate controlling step. Similarly, Liotta et al. (1987) observed zero-order reaction rates in the absence of water, indicating that mass transfer could be the controlling rate, whereas in the presence of trace amounts of water, a pseudo-first-order reaction rate was observed.

Melville and Goddard (1985) were among the first to recognize that SLPTC involves a combination of effects of reac-

tion enhanced transport and mass-transfer limited reaction. They developed a model for SLPTC based on the film theory and also a relatively exact model based on laminar forced convection in the von Karman flow field around a rotating disk of the solid reagent. Using a pseudo-steady-state assumption, and after suitable manipulations of the mass balance equations for different species and the boundary conditions, Melville and Goddard (1985) obtained an equation for the concentration of QY, with RX concentration related to it linearly, via constants A_1 and A_2 which are determined from the boundary conditions

$$\frac{\partial^2 C_{QY_0}}{\partial x^2} = Da \left[C_{QY_0} (C_{RY_0}^0 - C_{RY_0}) - \frac{1}{K} (q_0 - C_{QY_0}) C_{RY_0} \right] \quad (16)$$

$$C_{RY_0} = A_1 z + A_2 - \frac{D_q}{D_{RY}} C_{QY_0} \quad (17)$$

The above equation was solved for different limiting cases and the reader is referred to the original articles for more details. Mass-transfer steps in the PTC cycle were characterized by surface and bulk Damkohler numbers and the film-model effectiveness factor. The surface Damkohler number Da_s is defined to characterize the rate of surface reaction in relation to the rate of diffusion, while the effectiveness factor η gives the ratio of reaction rate on the solid surface in the presence of mass-transfer limitations to that without these limitations. Both analytical and numerical solutions showed that the effectiveness factor decreases with increasing surface (ion-exchange) reaction, but increases with increasing bulk (organic) reaction rate. No substantial practical errors were anticipated in the film model, which gave results almost identical to the more rigorous rotating disk (Levich) model (Figure 7).

Melville and Yortos (1986) consider the case of SLPTC with rapid homogeneous reaction based on the stagnant film model. Concentration profiles for quat species within the boundary layer at the surface of the solid reactant were plotted for various equilibrium constant values for high and low values of surface Damkohler numbers (Figure 8). Maximum catalyst efficiency is obtained at large surface Damkohler numbers and with irreversible reactions. A thin reaction zone may develop depending on the values of surface Damkohler number with the thickness of the reaction zone dependent on both bulk and surface Damkohler numbers. It was also suggested that solubilization of the solid reagent can be an important rate-determining step in homogeneous solubilization.

Naik and Doraiswamy (1997) developed a modeling strategy for SLPTC based on the homogeneous and heterogeneous mechanisms for SLPTC. Modifications of these models have to be considered while modeling SLPTC systems with reaction in the organic bulk in the absence of PTC. The models also need to be suitably modified for reactions taking place in the presence of traces of water. A series of models were developed for homogeneous solubilization, where the different controlling steps are progressively accounted for, until finally a model (Model D) that incorporates all possible sources of resistance is obtained: solid dissolution, ion exchange, and mass transfer of quat and the organic reaction. The different

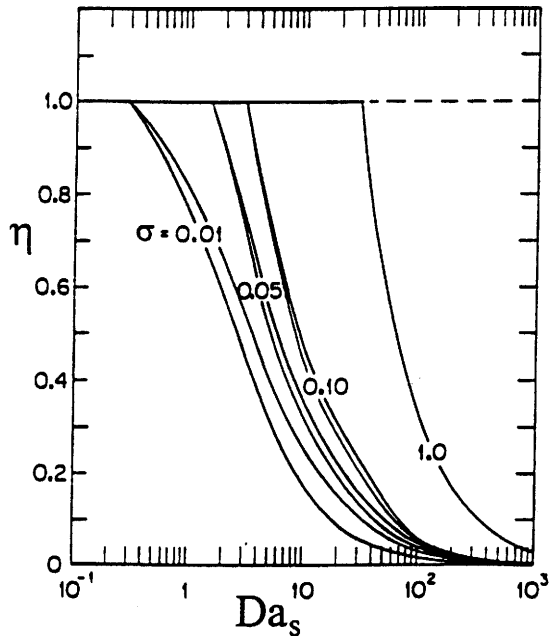

Figure 7. Rotating disk effectiveness for rapid irreversible reaction.

Upper and lower curves are for film and Levich models, respectively. In this figure $\sigma = D_{RX}/D_{QY}$ (adapted from Melville and Goddard, 1985).

possible models are shown in Figure 9 and their features are summarized in Table 3. The model equations are nondimensionalized in terms of the usual Thiele parameter, Biot number for mass transfer, and nondimensional time and distance. A comparison of the conversion X and the quat concentration C_{QY} for the different models is shown in Figure 10. Due to the additional rate limiting steps incorporated into the analysis in going from Model to A to D, we see a progressive

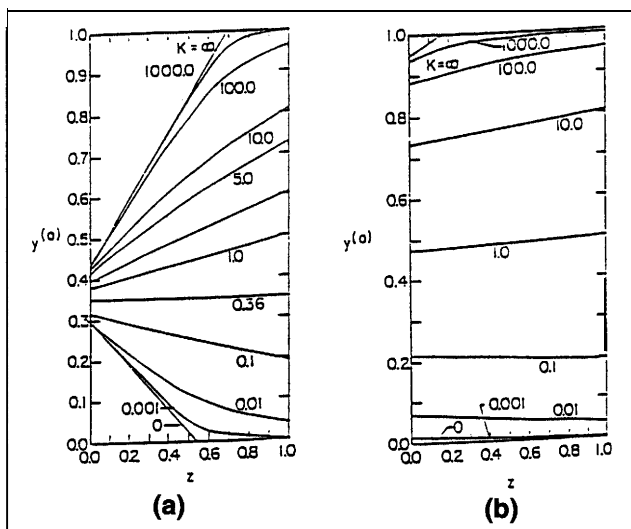
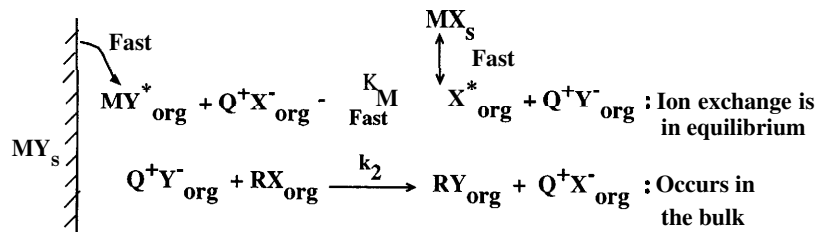

Figure 8. QX concentration profile within the film for various K values.

(a) $Da_s = 10$; (b) $Da_s = 0.5$ (adapted from Melville and Yortos, 1986).

Model A



Model B

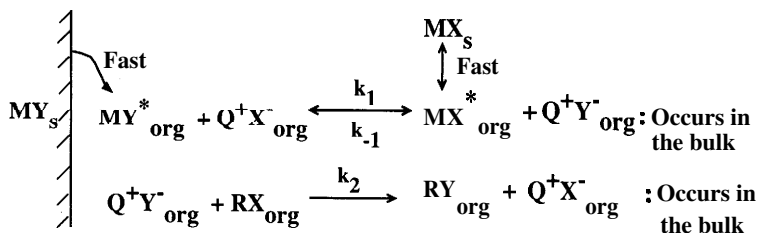

Model C

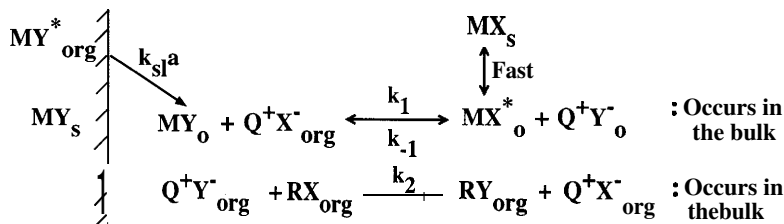

Model D

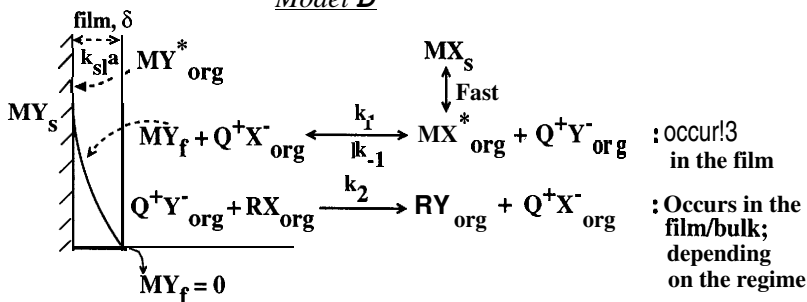

Figure 9. Models for homogeneous solubilization.

Adapted from Naik and Doraiswamy (1997).

decrease in the reaction rate, and hence in the conversion. Thus, an assumption of constant QY and pseudo-first-order reaction rate can lead to a gross overestimate of the expected conversion. Figure 10b shows that the quat concentration is not constant (as in usually assumed), but gradually builds up from zero to unity as time increases.

A comprehensive model for heterogeneous solubilization was also developed by Naik and Doraiswamy (1997), which accounts for ion exchange in the solid phase, interphase transport of the quat species, and the organic reaction. In this case, ion exchange taking place in the solid phase can be one of the rate controlling steps, since access to the anions in

the solid can be restricted by mechanical hindrances due to the lattice structure and the deposition of the product MX . For a reactive solid, transient conditions prevail within the solid and the controlling regime can continually shift with time. Structural changes within the solid with reaction can also affect the rates of the individual steps. In the general case, the controlling steps can either be the liquid-phase transfer steps (external mass transfer), the diffusion steps with the reactive solid, the adsorption-desorption steps (if any), the surface (ion-exchange) reaction, or the liquid-phase organic reaction. Depending on the porosity of the solid and other factors, different models can be chosen for the ion-ex-

Table 3. Summary of Models for Homogeneous Solubilization*

Model	Step(s) Contributing to Overall Rate	Characteristic Features of the Model	Regime of Ion Exchange	Regime of Organic Reaction
Model A	Organic phase reaction	Constant Q^+Y^- concentration Pseudo-first-order rate	(4, at equilibrium)	1
Model B	Organic phase reaction and ion exchange	Changing Q^+Y^- concentration	1	1
Model C	Organic phase reaction, ion exchange, and solid dissolution	Rate of solid dissolution important at low values of $k_{s1}a$	Between 1 and 2	1
Model D	Organic phase reaction, ion exchange, solid dissolution, and mass-transfer steps	Mass-transfer limitations slow down reaction	3	1, 2, or 3

*Adapted from Naik and Doraiswamy (1997).

change step. Considering a volume reaction model, similar to those developed for gas-solid reactions, they developed the following equations for the PTC cycle

$$\frac{\partial C_{QX}^s}{\partial t} = \frac{D_e}{r^2} \frac{\partial \left[r^2 \frac{\partial C_{QX}^s}{\partial r} \right]}{\partial r} - k_s \left(C_{QX}^s - \frac{C_{QY}^s}{K} \right) \quad (18)$$

$$\frac{\partial C_{QY}^s}{\partial t} = \frac{D_e}{r^2} \frac{\partial \left[r^2 \frac{\partial C_{QY}^s}{\partial r} \right]}{\partial r} + k_s \left(C_{QX}^s - \frac{C_{QY}^s}{K} \right) \quad (19)$$

$$\frac{dC_{RX_s}}{dt} = k_2 C_{RX_b} C_{QY_b} - k_q a [C_{QX_b} - C_{QX_s}] \quad (20)$$

$$\frac{dC_{RX_b}}{dt} = -k_2 C_{RX_b} C_{QY_b} \quad (21)$$

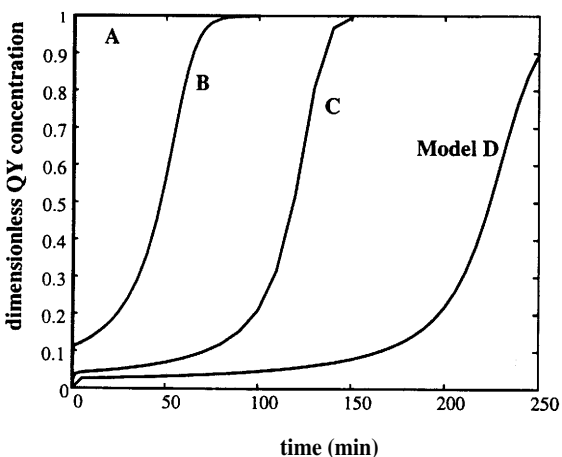
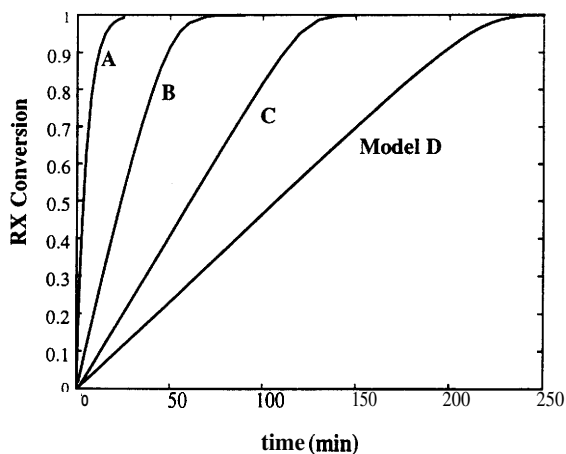

Figure 10. Comparison of models for homogeneous solubilization.

Adapted from Naik and Doraiswamy (1997).

with C_{QY_b} calculated from a quat species balance as

$$c_{QY_b} = q_o - C_{QX_b} - C_{QX_a}^s - C_{QY_a}^s \quad (22)$$

where $C_{QX_a}^s$ and $C_{QY_a}^s$ are the volume average concentrations of QX and QY in the solid. Initial condition(IC)

$$t = 0, C_{RX_b} = C_{RX}^0, C_{QX}^s = 0, C_{QY}^s = 0, C_{QX_b} = q_o, C_{QY_b} = 0 \quad (23)$$

Boundary conditions (BC)

$$r = 0, \frac{dC_{QX}^s}{dr} = \frac{dC_{QY}^s}{dr} = 0 \quad (24)$$

$$r = R, D_q \frac{dC_{QX}^s}{dr} = k_q [C_{QX_b} - C_{QX_s}^s] \quad (25)$$

$$r = R, D_q \frac{dC_{QY}^s}{dr} = k_q [C_{QY_b} - C_{QY_s}^s] \quad (26)$$

Constant diffusivity (D_q) and the solid-liquid mass-transfer coefficient (k_q) are assumed for QX and QY. The model equations are nondimensionalized in terms of the Thiele parameter ϕ^2 , Biot number for mass transfer Bi_m , and nondimensional time and distance. An important conclusion from the subsequent analysis of the model simulations is the importance of the solid phase on the conversion of the organic substrate in the organic phase. Results of their simulation are shown in Figure 11. It can be noticed that at low ϕ^2 , corresponding to low diffusional limitations, the overall organic reagent conversion is lower than at higher values of ϕ^2 . This result is the exact opposite of what is observed in analysis of

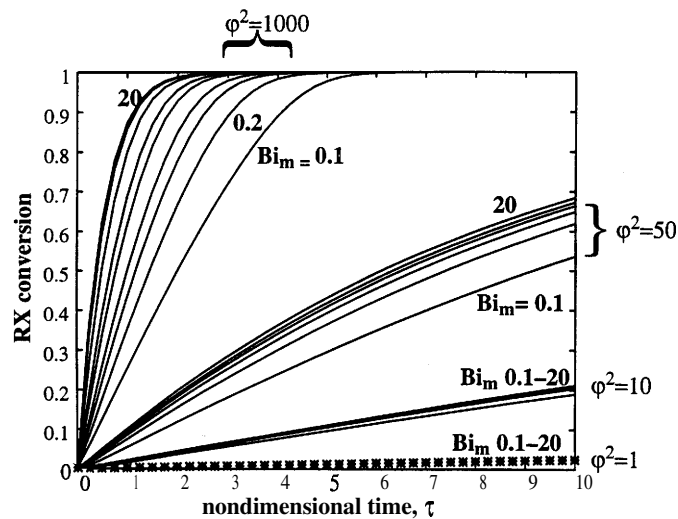

Figure 11. Effect of solid phase mass-transfer limitations in heterogeneous solubilization.

Adapted from Naik and Doraiswamy (1997).

diffusion effects in traditional heterogeneous catalysis. This is because, while traditional fluid-solid reactions involve a consideration of the effect of solid phase diffusion on the reaction occurring within the solid phase, the analysis for heterogeneous solubilization involves a study of the effect of solid-phase diffusion and reaction on the reaction taking place in the surrounding liquid phase. Thus, higher values of ϕ^2 , indicative of higher diffusional limitations, give higher overall RX conversions, as in this case ion exchange is much faster than the diffusional effects and significant amounts of QY are generated at the solid interface for consumption in the organic liquid-phase reaction. On the other hand, with low values of ϕ^2 , ion-exchange reaction within the solid is too slow to deliver sufficient quantities of the quat species QY into the liquid phase. Also, film transfer limitations can become important at higher values of ϕ^2 , where the rate of the ion-exchange reaction is fast compared to diffusional effects within the solid and its neighborhood (that is, the liquid film at the solid-liquid interface).

It should be noted that in the general case both homogeneous and heterogeneous solubilization could be occurring in an SLPTC system. Since the analysis for each of the individual models is so complicated, developing a general overall model is very difficult. Instead, the overall rate can perhaps be obtained by merely adding the rates of reaction predicted by the individual models. It is anticipated that the heterogeneous solubilization model will contribute largely to the overall reaction rate in most cases, although the contribution of homogeneous solubilization cannot be discounted in the case of reactions where the solid phase has a finite solubility in the organic solvent.

Insoluble PTC

Removal and recovery of the PT catalyst from the organic phase, in which it is predominantly soluble, can be a very expensive and difficult process, especially since the product which is also in the organic phase is desired in very high pu-

rity for most specialty chemical applications. If one can restrict the PT catalyst to a third insoluble phase (liquid or solid), then the separation step can be carried out more easily. However, introduction of a third catalyst phase introduces new diffusion and interphase transfer limitations. For example, a large number of studies have reported the immobilization of the PT catalyst on a solid support (triphase catalysis). However, higher costs, lower stability, and lower reactivity (than the soluble analogs) due to diffusional limitations have not made it feasible to use triphase catalysis on an industrial scale so far. Recently, the use of a third catalyst-rich liquid phase has been reported, and this is discussed below.

Third liquid phase

Recently, a large number of studies on the use of a catalyst-rich third liquid phase in PTC systems have been reported. For example, Wang and Weng (1988,1995), Ido et al. (1995a,b) and Mason et al. (1991) report detailed studies on the use of a third catalyst-rich phase formed under suitable conditions in liquid-liquid systems. In some cases reaction rates higher than that possible with insoluble solid catalysts and even soluble catalysts are possible using a third liquid phase.

Often, reaction is very slow even in the presence of a PT catalyst due to limited solubility of the quat in the organic solvent (such as TBAB in toluene). However, if the quat concentration is increased, at a certain critical concentration, a sudden jump in reaction rate is observed. This corresponds to the critical point where a third phase is formed, identifiable by the formation of droplets at the interface. At still higher concentrations, a distinct continuous third liquid phase is noticeable. Analysis of this third phase shows that it is rich in the PT catalyst, contains little organic solvent or the aqueous nucleophile, and only small quantities of water. Thus, the PT catalyst is concentrated in a third liquid phase, distinct from the aqueous or the organic phase, which makes recovery and recycle of the catalyst easy. Ideally, it is possible to have a rapid rate of reaction, followed by easy separation of organic and aqueous phases with the third catalyst-rich phase being easily recycled. Reuse of the catalyst-rich phase is possible as the catalyst does not degrade or lose its activity during reaction (Wang and Weng, 1988; Ido et al., 1995a,b).

Wang and Weng (1988) suggested that both organic and inorganic reagents are transferred to the catalyst-rich third phase where both ion exchange and the organic reaction occurs, Wang and Weng (1995) have developed a more detailed mechanism where three different reaction scenarios are possible involving reaction in the organic phase, reaction at the interface of the organic and aqueous phases, and reaction in the catalyst-rich third phase. Neumann and Sasson (1984) studied the isomerization of allylanisole to anethole in a reaction mixture comprising an organic solvent phase, a basic aqueous phase, and a third PEG-rich PEG-KOH complex phase. Important steps in the catalytic cycle included diffusion of the substrate from the solvent to the complex phase, where isomerization occurs, followed by back-diffusion of the product. Hydroxide ion transfer from the aqueous phase to the catalyst complex phase is necessary and a saturation or super saturation level of KOH in the aqueous phase is required for reaction. Thus, the mechanism of reaction is

slightly different here from the typical PTC cycle, which involves ion exchange at the interface or in the aqueous phase and the main reaction in the organic phase. A physical model developed by Mason et al. (1991) for the third liquid-phase PTC system considers a concentric arrangement of dispersed droplets of one phase (aqueous NaOH) coated by a thick layer of the catalyst-rich liquid suspended in the continuous liquid phase (toluene).

Further studies on the use of a third liquid-phase PT catalyst are required to completely understand its mechanism and kinetics, and tap any possible benefits. Note that it is not always possible to have a third liquid phase and, hence, this method has limited applicability in PTC technology.

Immobilized phase-transfer catalysts

Significant process simplifications are possible if the quat can be immobilized on a solid support, whereby separation and recycle of the catalyst are easily carried out by merely filtering it out. Indeed, since as early as 1975 (Reger 1975), various attempts have been made to use PT catalysts immobilized on solid supports (for reviews, see Ford and Tomoi, 1984; Desikan and Doraiswamy, 1995). Quats, crown ethers, cryptands, and PEGs have all been immobilized on various kinds of supports ranging from polymers (most commonly, polystyrene cross-linked with divinylbenzene), alumina, silica gel, clays, and even zeolites. However, immobilized catalysts suffer from the disadvantages of low activity, mostly due to diffusional limitations, and higher costs. Thus, industrial applications of immobilized PT catalysts (or triphase catalysts (TPC), as they are commonly called) are almost nonexistent. This unfortunate lack of technology for industrial scale-up of triphase catalysis is mainly because of a lack of understanding of the complex interactions between the three phases involved in such a system. Besides the support macrostructure, the support microenvironment is crucial in triphase catalysis, since it decides the interactions of the aqueous and the organic phases with the PT catalyst immobilized on the support surface. In fact, besides serving as macroscopic handles that facilitate recovery of catalyst, the support can lead to some interesting selectivity features (some illustrative examples are discussed later) due to the specific interactions of the support with the two phases that contain the reagents. Another advantage of triphase catalysis is that it can be easily adapted to continuous processes (Ragaini, 1986, 1988, 1990).

Choice of Support. The most commonly used organic support is polystyrene (cross-linked with DVB) in its microporous (1-2% cross-linking) form, although it has also been used in its macroporous and popcorn form (Ford et al., 1982; Shan et al., 1989). Various other polymeric catalysts have been used like polyvinylpyridine resins, commercial ion-exchange resins (Arrad and Sasson, 1989), modified dextran anion exchangers (Kise et al., 1981), and macroporous glycidyl methacrylate-ethylene dimethacrylate resins (Hradil and Svec, 1984). Inorganic solids like alumina, silica gel, silica, and clays have also been used to support quaternary ammonium salts. Inorganic supports like silica (Arrad and Sasson, 1990), silica gel (Tundo and Venturello, 1981), alumina (Tundo et al., 1982), zeolites (Tundo et al., 1985) have been impregnated with quaternary salts and used in gas-phase halogen exchange reactions. PEGs have also been immobilized on metal

oxide surfaces (Sawicki, 1982) and used effectively in displacement and oxidation reactions.

Refer to comprehensive reviews on polymer supported PTC (see Ford and Tomoi, 1984) for a detailed analysis of the various important factors in polymer supported PTC. However, since inorganic supports also have great potential as supports in PTC reactions, they are discussed here in some detail to bring out some of their advantages over traditional polymer supports. The use of inorganic solids as supports for PT catalysts leads to some interesting interactions between the catalyst, support, and the reagents, which might be responsible for the alteration in reaction course and selectivity. For example, silica gel supported phosphonium salts are more active than the analogous soluble catalyst in the reduction of ketones with sodium borohydride and in the synthesis of primary alkyl chlorides from primary alcohols (Tundo and Venturello, 1979). Its higher reactivity is perhaps explained by the adsorption of the organic substrate on silica gel which increases its concentration on the support.

In general, the PT catalyst is either physically adsorbed on an inorganic support matrix (Tundo et al., 1982), or is chemically bonded to long spacer groups to create an organophilic environment for reaction (Tundo and Venturello, 1979). The chemisorbed catalysts are found to be more robust and consistent in their performance with higher activity. Unlike in polymer supported catalysts, using silica gel as the support, Tundo (1977) found short spacer chains to give higher activity than long spacer chains in two different substitution reactions and a borohydride reduction. This is explained by the fact that catalysts with short spacer chains do not affect the polarity of the support or its availability for substrate adsorption. The presence of a hydrophobic spacer chain decreases the polarity of the support surface, and, hence, its adsorption capacity. Alumina is found to be more stable in alkali than silica gel and also shows higher activity and selectivity in some reactions. This is probably because alumina, by itself, can catalyze various heterogeneous reactions (Ando et al., 1984; Quici and Regen, 1979; Pradhan and Sharma, 1992). Alumina offers a highly polar environment that alters the microenvironment of the reaction site and provides a highly favorable situation for substitution reactions (Tundo and Badiali, 1989).

Clays and zeolites can also act as efficient, inexpensive, stable, and recyclable catalyst supports. Clays (Cornelius and Laszlo, 1982; Sarkar et al., 1989; Choudhary et al., 1991; Lin and Pinnavaia, 1991) especially seem to be feasible for commercial exploitation due to their low costs. The negatively charged sheets in clays like montmorillonite can act as effective counterions for the quaternary salt cations. Clays, and, more so, zeolites, with their well defined chemical and morphological characteristics can be used in the synthesis of highly stereoselective and chiral products. Their negatively charged aluminum silicate structure with strong electrostatic interactions governing adsorption can be used to physically or chemically adsorb quaternary onium salts. Lin and Pinnavaia (1991) reported that when quaternary onium salts are adsorbed on clay (hectorite), a thin membrane-like assembly of platelets forms at the liquid-liquid interface of an oil-in-water system. The clay surface is covered with quat salts with long alkyl chains that extend outwards and are permeable to both aqueous and organic phase reactants. However, surface

modification methods to graft reactive molecules to the available hydroxyl groups on the clay surface through coupling agents lead to low loading capabilities. To have higher loading possible and still retain the advantages of using clay as a support, Akelah et al. (1994) supported phosphonium moieties on a polymer-clay composite, which was synthesized by grafting copolymers of styrene and chloromethylstyrene with 2% ammonium salts onto montmorillonite interlayers by a cation exchange process.

Mechanism of Triphase Catalysis. Although the activity of a supported PT catalyst is usually less than that of the corresponding soluble catalyst, it is believed (Molinari et al., 1979; Montanari et al., 1983, Anelli et al., 1984) that the mechanism of the phase-transfer cycle remains the same. However, there are certain characteristics typical of heterogeneous catalysts that make supported PTC different from soluble PTC. For example, in a triphase catalytic system, one does not consider the planar phase boundary as in a classical two-phase system. Instead, a volume element which incorporates the catalytic active sites as well as the two liquid phases has to be considered. Diffusion of both the aqueous and organic phases within the solid support is important. Various mechanisms have been proposed for triphase catalysis, some of which are touched upon here. However, it should be noted that no single mechanism has been verified completely, and it is quite possible that the true mechanism involves a combination of the various mechanisms proposed so far.

Like in traditional heterogeneous catalysis, the kinetics of supported PTC is influenced by three fundamental processes:

- (1) Mass transfer of reactants from bulk liquid phase to the surface of the catalyst particle.
 - (2) Diffusion of the reactant molecules from the catalyst particle surface to the active sites within the porous particle.
 - (3) Intrinsic reactivity of reaction at the active sites.
- Triphase catalysis is more complicated than traditional heterogeneous supported catalysis, because it involves not merely diffusion of a single gaseous or liquid phase into the solid support but requires the diffusion of both the aqueous phase (for ion exchange to take place) and the organic phase (for the organic reaction to take place) to the solid surface and within the solid (Figure 12). The fact that the aqueous phase and the organic phase interact differently with different solid supports further complicates the issue. In a typical triphase system, since the catalyst support is usually lipophilic, the organic phase fills the catalyst pores and forms the continuous phase with the dispersed aqueous phase droplets diffusing through it to reach the quat species immobilized at the solid surface. Also, the choice of support can sometimes alter the reaction mechanism. For example, Tundo and Venturello (1981) reported a mechanism for PTC reactions using silica gel as support, which accounted for the active participation of the gel by adsorption of reagents,

In general, any mechanism for triphase catalysis has to account for the interaction of two immiscible phases with a solid bound catalyst. Telford et al. (1986) suggested an alternating shell model that requires periodical changes in the liquid phase filling the pores of the catalyst pores. Schlunt and Chau (1986) from the same research group tried to validate this model using a novel cyclic slurry reactor that allowed the organic and aqueous phases to contact the catalyst sites icon-

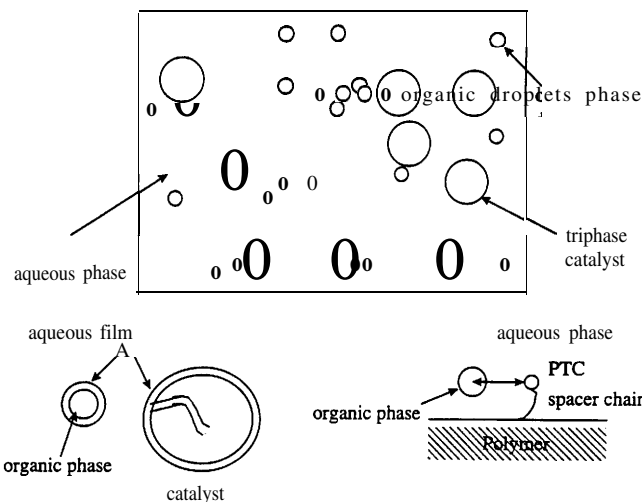

Figure 12. Plausible mechanism for liquid-liquid-solid triphase catalysis.

Adapted from Desikan and Doraiswamy (1995).

trolled sequential steps. Their results indicated that only the catalyst in a thin shell near the particle surface was utilized. We do not fully comprehend the driving force for the alternative exchange of liquids within a solid support, since a solid support particle is either hydrophilic or lipophilic, and cannot alternate between the two. A more realistic mechanism (Tomoi and Ford, 1981; Hradil et al., 1988) involves the collision of droplets of the organic (or aqueous) phase with solid catalyst particles dispersed in a continuous aqueous (or organic) phase. The hydrophilic (or lipophilic) nature of the support determines which phase fills the pores of the catalyst and acts as the continuous phase. Svec's model (Svec, 1988) for transport of the organic reagent from the bulk phase through water to the catalyst particle has been developed in terms of emulsion polymerization (Figure 13). Since free migration of the ion pairs between phases is not possible because the cation is part of the solid support, it is necessary for the immobilized PT catalyst to be just at the boundary of the two phases or to fluctuate between the two. The presence of spacer chains is believed to help such an oscillation of the

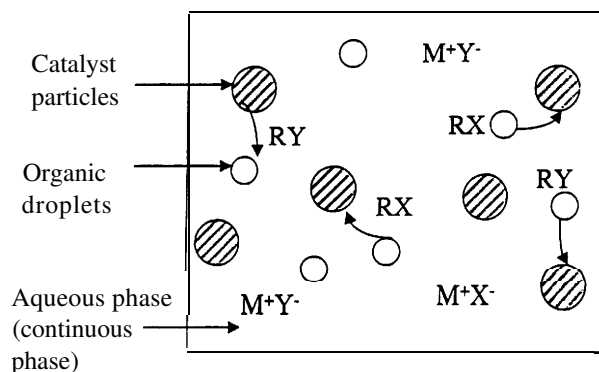

Figure 13. Mechanism of triphase catalysis based on emulsion polymerization.

Adapted from Svec (1988).

catalyst between the aqueous and organic phases, assuming both these phases are present within the pores of the solid support.

Various other mechanisms have also been proposed to explain the complex interaction between the catalyst and the two liquid phases, and the transport of compounds within the solid support. Hradil et al. (1987) demonstrated that the transfer of reactive species between phases inside the catalyst particle is guided by conformational changes in the polymer chain which cause oscillations of the immobilized cation between the two phases, both of which are present within the polymer matrix. Rate limiting steps in a triphase catalytic system are believed to be related to the frequency of oscillation of reactive sites within the solid support. Thus, PT catalysts supported on macroporous polymers or highly cross-linked beads, which do not swell in solution, are found to be ineffective catalysts due to the severe restrictions within the support not only to diffusion of species within the pores of the solid but also to the oscillation of the reactive groups between the phases. The mobility of the cation-bearing chain thus determines the effectiveness of the immobilized PT catalyst, whereas the hydrophilic-lipophilic balance of the support structure determines the distribution of the two phases within the solid support pores (Ruckenstein and Park, 1988, Ruckenstein and Hong, 1992). The catalytic functional groups within the polymer matrix determine the microenvironment of the support structure, which in turn affects the overall reactivity.

The case of liquid-solid-solid systems is even more complicated since the solid nucleophilic reagent has to come in contact with the solid catalyst particles for ion exchange to occur (plausibly involving a solid-solid reaction), followed by contact of the solid catalyst particles with the liquid for the main organic reaction (Figure 14). MacKenzie and Sherrington (1981) conducted a detailed mechanistic study of a liquid-solid-solid reaction and concluded for the system studied that transfer of the nucleophilic reagent to the catalyst surface occurred by direct contact between the two insoluble solids. Addition of traces of water increased the rate of reaction, as in SLPTC systems, possibly by increasing the rate of transfer of the inorganic reagent to the catalyst. It has also been hy-

pothesized (Yanagida et al., 1979) that reaction in a liquid-solid-solid system is possible due to dissolution of the solid nucleophile in the organic reagent (analogous to homogeneous solubilization in SLPTC), followed by transport of the dissolved species in the organic liquid into the solid, Kondo et al. (1994) also suggest direct solid-solid interaction leading to the formation of a complex between the solid nucleophilic reagent and the solid polymeric support by the cooperative coordination of active sites in the polymer and the alkali metal ion of the reagent. On the other hand, a simple extraction mechanism similar to classical PTC has been suggested by Arrad and Sasson (1991) with reaction rates being controlled by either mass transfer of the inorganic reagent by small amounts of water or the organic phase chemical reaction. Ion exchange is believed to proceed by transportation of nucleophile into the solid catalyst pores via dissolution in the traces of water which are always present and form a fourth saturated phase in the system. In the absence of water, direct interaction of the nucleophile with the surface of catalyst can lead to small amounts of reaction, although traces of water help increase the mass transfer of the nucleophile. Similarly, Arrad and Sasson (1990) also reported that the ion-exchange reaction takes place on the surface of the silica support which was impregnated with onium salts. Thus, the mechanism of reaction in liquid-solid-solid systems is far from clear and needs considerable further investigation. An interesting version of liquid-solid-solid PTC is reported by Nishikubo et al. (1983) and Iizawa et al. (1987) who conducted the reaction of insoluble polystyrene with a solid nucleophilic reagent mediated through an organic solvent which contained a PT catalyst. This is an example of a solid-solid reaction that is made possible by adding a third liquid phase, whereby finite amounts of the nucleophilic reagent dissolving in the organic phase are picked up by the quaternary ammonium salt (PT catalyst) present in the organic phase and transported to the relatively polar solid polymer phase, where it undergoes the substitution reaction.

Kinetics and Modeling of Triphase Catalysis. So far only the qualitative features of the factors affecting triphase catalysis were discussed. Modeling the complex dynamics of diffusion and reaction in a triphase system is difficult without a better understanding of the mechanism involved. Besides, the effects of a number of variables that influence the performance of a triphase catalyst have not been quantitatively understood. Thus, it is not surprising that only a few articles have reported detailed kinetic and modeling studies on TPC. These articles all deal with liquid-liquid-solid systems and to the best of our knowledge, no studies dealing with the modeling of liquid-solid-solid systems have been reported so far.

Marconi and Ford (1983) were among the first to model triphase catalysis based on standard equations developed for porous catalysts in heterogeneous catalysis. They derived an expression for the effectiveness factor to describe the effects of mass-transfer resistances outside and within the supported catalyst particles. The model considers the mass transfer of the organic substrate from the organic bulk to the surface of the catalyst and subsequent diffusion of the organic substrate into the pores of the catalyst, followed by the main organic reaction inside the catalyst. With these assumptions, equations from traditional heterogeneous catalysis can be adapted to TPC, to give at steady state

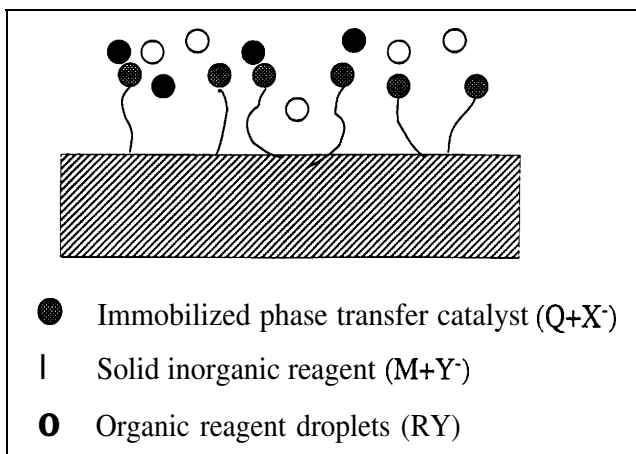

Figure 14. Plausible mechanism for liquid-solid-solid triphase catalysis.

Adapted from Desikan and Doraiswamy (1995).

$$-r_{RX_0} = \left[\frac{R_c V_o}{3V_{cat} k_{lRX}} + \frac{V_o}{k\lambda M_c \eta_c} \right] = {}^{-1}C_{RX_0} = k_{obs} C_{RX_0} \quad (27)$$

where the catalytic effectiveness η_c for spherical pellets is given as a function of the Thiele Modulus ϕ as

$$\eta_c = \frac{3\phi \coth(3\phi) - 1}{3\phi^2} \quad (28)$$

$$\phi = \frac{R_c}{3} \sqrt{\frac{k_2 M_c \lambda_c}{V_{cat} D_e}} \quad (29)$$

Thus, the reciprocal observed rate constant k_{obs} is the sum of two resistances in series, the former due to film diffusion and the latter due to both intrinsic reactivity and particle diffusion. An overall effectiveness factor can be defined to incorporate the film diffusion resistance in addition to the interparticle diffusional resistance as

$$\eta_o = \frac{\eta_c}{1 + \phi^2/Bi_m} \quad (30)$$

However, this model makes many simplifying assumptions that do not apply to the typical triphase catalysis problem. Only the organic phase has been considered explicitly and the kinetics of the ion-exchange reaction and any resistance to the transport of aqueous phase reagents from the aqueous bulk to the surface of the solid catalyst and within the solid catalyst is ignored. As discussed in the previous section, triphase catalysis involves the diffusion and reaction of two immiscible liquid phases within the solid phase, and any model for triphase catalysis has to consider the mass transfer of both organic and aqueous phases from their respective bulk phases to the surface of the catalyst, diffusion of the aqueous and the organic phase through the pores of the solid catalyst, the intrinsic kinetics of reactions at the immobilized catalyst sites, and the diffusion of products back to the catalyst surface and into the bulk solutions. Assuming the organic phase to be the continuous phase with dispersed aqueous-phase droplets, mass-transfer resistances for the aqueous-phase reactant include the aqueous film resistance at the aqueous-organic interface and the organic film resistance at the organic liquid-solid particle interface. For the organic-phase reactant film, diffusional limitations are restricted to that at the organic liquid-solid particle interface. In addition to the film resistances, internal diffusional limitations within the pores of the solid catalyst are also to be considered. Thus, simple extension of traditional heterogeneous immobilized catalyst systems to triphase catalysis cannot be made.

Wang and Yang (1991b) have proposed a more realistic model for triphase catalysis in a batch reactor, where they consider mass transfer of reactants in the bulk aqueous and organic phases, diffusion of reactants within the pores of the solid catalyst particle, and intrinsic reactivities of the ion-exchange and organic reactions at the active sites within the solid catalyst. An apparent overall effectiveness factor of the catalyst is obtained in this case by applying the pseudo-

steady-state assumption to the mass balance equations within the catalyst, as

$$\eta_o = \frac{3}{\phi_{app}^2} \left[\frac{\phi_{app} (\coth \phi_{app}) - 1}{1 + (\phi_{app} (\coth \phi_{app}) - 1)/Bi_m} \right] \quad (31)$$

where ϕ_{app} is the apparent Thiele modulus, and Bi_m is the Biot number that characterizes the external mass-transfer resistance.

$$\phi_{app} = \left[\frac{R_c (k_2 \rho_c q_o / D_{RX})^{0.5}}{\left(1 + \left(\frac{D_{QY} k_2}{D_{RX} k_1} \right) \right)} \right]^{1/2} \quad (32)$$

A more general dynamic model was developed by Wang and Yang (1992), and further modified by Desikan and Doraiswamy (1995) to account for the effect of the reversibility of the ion-exchange reaction. Relevant equations are:

Mass Balance of Quat within Catalyst

$$\frac{\partial C_{OX}}{\partial t} = k_1 C_Y C_{QX} + k_{-1} C_X C_{QY} + k_2 C_{RX} C_{QY} \quad (33)$$

Mass Balance of Organic Substrate within Catalyst

$$\epsilon_{org} \frac{\partial C_{RX}}{\partial t} = \frac{D_{Ye}}{r^2} \frac{\partial}{\partial r} \left[r^2 \frac{\partial C_{RX}}{\partial r} \right] - \rho_c k_2 C_{RX} C_{QY} \quad (34)$$

Mass Balance of Inorganic Species within Catalyst

$$\epsilon_{aq} \frac{\partial C_Y}{\partial t} = \frac{D_{Ye}}{r^2} \frac{\partial}{\partial r} \left[r^2 \frac{\partial C_Y}{\partial r} \right] - \rho_c k \left(C_Y C_{QX} - \frac{1}{K_{eq}} C_{QY} C_X \right) \quad (35)$$

with ionic species balance in the aqueous phase giving $C_X = C_Y^0 - C_Y$, and a quat balance giving, $C_{QY} = q_o - C_{QX}$. Bulk-phase concentrations are coupled to the conditions within the catalyst through the boundary conditions. Bulk-phase mass balances are required to keep track of changes in the bulk-phase organic and aqueous reagent concentrations

$$-\frac{dC_{RX_b}}{dt} = k_{RX} a(V_{cat}/V_o)(C_{RX_b} - C_{RX_s}) \quad (36)$$

$$-\frac{dC_{Y_b}}{dt} = k_Y a(V_{cat}/V_o)(C_{Y_b} - C_{Y_s}) \quad (37)$$

These equations were nondimensionalized in terms of physically relevant parameters like the Thiele modulus and the Biot number for mass transfer, and an expression for overall effectiveness factor derived. An apparent rate constant for the organic reaction was derived as a function of both internal and external mass-transfer resistances

$$k_{app} = \frac{V_{cat}}{V_o} \left[\frac{1}{k_{RX}a} + \frac{1}{\eta_c \rho_c k_2 (q_o - C_{QX_s})} \right] \quad (38)$$

Figure 15 shows a typical plot of intraparticle effectiveness factor vs. nondimensional time for different values of the Thiele modulus. It should be noted that the reversibility of the aqueous phase ion-exchange reaction led to lower effectiveness factors than the simulations by Wang and Yang (1991b) for irreversible reactions.

Activity and Selectivity of Supported PT Catalysts. In general, supported catalysts are known to be less active than their soluble analogs due to diffusional limitations. However, in the case of triphase catalysis, due to the complex interactions between the solid phase and the two liquid phases, it is sometimes possible that the supported catalyst shows higher reactivity than its soluble counterpart. For example, immobilized PEG showed lower activity than the soluble analogs at equivalent concentrations, except for mono- and diethylene glycol derivatives which showed greater activity in their immobilized form (Kimura and Regen, 1983a). Similarly, McKenzie and Sherrington (1981) found that supported PEG catalysts gave equal or nearly equal activity as their soluble analogs in the reaction of alkyl bromides with potassium phenoxide. Hradil and Svec (1984) observed that PEG immobilized on amacroporous glycidyl methacrylate was more active than its soluble analogs in the reaction of *n*-butyl bromide with sodium phenoxide. Similarly, higher reactivity and selectivity are sometimes obtained due to interactions of the support with the reagents in the case of inorganic reagents like alumina or silica gel.

However, it should be noted that it is often possible that a hydrophilic catalyst like tetramethyl ammonium chloride or a quat like TBAB that partitions into the aqueous phase to a significant extent performs better in the lipophilic microenvironment of a polymer support. The lipophilicity of the polymeric support overcomes the hydrophilic nature of the onium

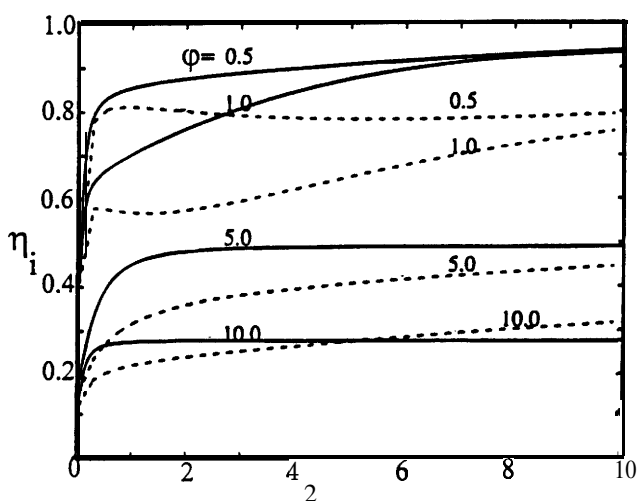

Figure 15. Intraparticle effectiveness factor vs. dimensionless time for different Thiele modulus values.

Solid lines represent irreversible reaction ($K \rightarrow \infty$) while dotted lines represent $K = 0.1$ (adapted from Desikan and Doraiswamy, 1995).

salt and increases the reaction rate. The higher reactivity observed with supported catalysts is thus explained by the fact that the localized catalyst concentration available for reaction in a triphase system can be higher than the quat concentration available for reaction in the organic phase with soluble PTC. Hence, this uncommon result of *higher* reactivity using triphase catalysis as compared to soluble PTC must be viewed in the right perspective, since triphase catalysis is still **plagued** by the usual diffusional limitations, and the rates observed are high only in relation to those obtained with a soluble PT catalyst that has partitioned more into the aqueous phase. The absolute values of local catalyst concentrations in the organic phases are different in the two cases and such a comparison is misleading, if not wrong. It is interesting to note from such examples that the best catalyst chosen for soluble PTC might not necessarily be a good catalyst for TPC, and vice-versa, since the polymer microenvironment can change the reactivities of the PTC catalyst. Further studies on these aspects of TPC are in progress in the senior author's (LKD's) laboratory, and some interesting results are expected to be published soon.

An interesting effect of the support **microenvironment** on the selectivity of reaction has been reported in the alkylation of β -naphthoxide with benzyl bromide (Ohtani et al., 1981). Selectivity could be manipulated merely by changing the degree of ring substitution (% RS) of the 1% DVB cross-linked polystyrene support. With a catalyst with 17% RS, O-alkylation was predominant (94%) while a catalyst with 52% RS gave 81% of the C-alkylation product. Differences in the microenvironment of the catalyst support were suggested as a possible explanation for this interesting observation. It is known that the dipolar aprotic environment favors O-alkylation in this reaction, while water favors C-alkylation. The latter catalyst was highly solvated by water and little by the organic solvent (toluene) used, while the former catalyst was moderately swollen by toluene and poorly by water. The authors postulate a mechanism similar to that of inverted micellar action for the reaction.

Capsule Membrane PTC. In a modification of triphase catalysis, hydrophobic onium salts or poly(ethylene oxide) were grafted onto the surface of a porous ultrathin nylon capsule membrane (Okahata and Ariga, 1986). Typical dimensions of the capsule membrane were 25 mm diameter and a thickness of 5 microns. The organic solvent with the organic substrate was trapped within this capsule with the nucleophilic reagent present in the outer aqueous phase. After reaction, the capsule was broken and the product recovered easily. The catalyst remained on the surface of the polymeric membrane. No induction time was required, as is needed while using polymer supports. Comparison of reactivities of the capsule membrane system to that observed by using soluble PTC in a stirred reactor showed that the capsule membrane showed the higher reactivity (Okahata and Ariga, 1986), possibly due to free movement of the onium salts attached to long graft polymer chains at the interface of the ultrathin (low diffusional limitations) membrane capsule. It is speculated that these spacer chains can even **form** a micellar like structure at the organic/water interface. However, kinetic analysis and experimental results were consistent with a PTC mechanism which apparently ruled out the possibility of a micellar or emulsion-like environment at the interface.

Capsule membrane PTC systems are more amenable to a mechanistic analysis than typical triphase systems where the mechanism of interaction between the aqueous and organic phases with the catalytic sites is complex and not understood. A mechanism for capsule membrane PTC involving mass transfer and surface reaction for both PTC and IPTC reactions has been developed by Yadav and Meht(1993), Yadav and Mistry (1995). A Langmuir-Hinshelwood type model with the anchored quaternary-nucleophile complex as the active site was assumed to govern the overall rate of reaction

$$-\frac{dC_{RX_{si}}}{dt} = Sk_2 \frac{K_{eq} C_{RX_{si}} \frac{V_a}{V_o} K_{qo} C_{MY_{so}}}{1 + K_{eq} C_{RX_{si}} + \frac{V_a}{V_o} K C_{MY_{so}}} \quad (39)$$

where C_{RX} and C_{MY_o} are the concentrations of RX and MY, respectively, at the surface of the membrane on the inner and outer sides, respectively.

Although capsule membrane PTC is not suitable for direct scale-up to industrial level due to the inconveniences of working with capsules, the principles can be exploited in membrane reactors, with the PT catalyst immobilized on the membrane surface. This would not only enable easy recovery of both aqueous and organic phases after reaction without any problems of emulsification, but also ensure that the PT catalyst does not contaminate the product in the organic phase. Using a membrane reactor will also ensure high mass-transfer rates due to high interfacial areas per unit volume of reactor. More importantly, it will open up possibilities for continuous operation.

Combinations of PTC with Other Rate Enhancement Techniques

With the growth of PTC, various new technologies have been developed where PTC has been combined with other methods of rate enhancement. In some cases, rate enhancements much greater than the sum of the individual effects are observed. Primary systems studied involving the use of PTC with other rate enhancement techniques include the use of metal co-catalysts, sonochemistry, microwaves, electrochemistry, microphases, photochemistry, PTC in single electron transfer (SET) reactions and free radical reactions, and PTC reactions carried out in a supercritical fluid. Applications involving the use of a co-catalyst include co-catalysis by surfactants (Dolling, 1986), alcohols and other weak acids in hydroxide transfer reactions (Dehmlow et al., 1985, 1988), use of iodide (traditionally considered a catalyst poison, Hwu et al., 1992; Yeh et al., 1988), or reactions carried out with dual PT catalysts (Szabo et al., 1987; Tsanov et al., 1995; Savelova and Vakhitova, 1995; Jagdale et al., 1996) have been also reported.

Since the various combinations of PTC with different rate enhancement techniques each form a field of their own, we only briefly consider the general principles involved in each case here. The various combinations studied along with typical examples of each are summarized in Table 4.

Reactions with PTC and a metal co-catalyst

A large number of reactions using metal complexes and PT catalysts together have been reported in organometallic chemistry. The role of the PT catalyst in these reactions is to transport the reagent anion or the anionic metal complex from the aqueous phase to the organic phase, where reaction occurs. Alper (1981, 1988) and Goldberg (1992) give comprehensive reviews of a number of metal complex catalyzed reactions under PTC conditions. A related field is the PT catalyzed transformations of organometallic complexes and is comprehensively reviewed by Goldberg (1992, Chapter 3). One of the most important applications of metal complex co-catalysis is in the carbonylation of alkyl and acyl halides, olefins, acetylenes, aziridines, azobenzenes, thiranes, and phenols. Transition metal co-catalyzed PTC systems are also useful in reactions that require inorganic species like hydroxide anion to complete the reaction sequence. Thus, metal carbonyls are converted to the corresponding anions by hydroxide ion in the aqueous phase (or on the surface of solid KOH or NaOH), followed by transfer of the anion to the organic phase by the PT catalyst. The bulk quat salts not only facilitate transfer of the anionic species into the organic phase but also activate the carbonyl anion and enhance the displacement of the carbonyl on the alkyl halide. This biphasic operation also limits or avoids side reactions of the organic halide with the hydroxide.

Ultrasound in PTC systems

Ultrasound (in the 20-100 kHz range) has been found to enhance reactions in both liquid-liquid and solid-liquid heterogeneous systems (Lindley and Mason, 1987; Einhorn et al., 1989). The chemical effects of ultrasound, attributed to intense local conditions generated due to cavitation, are usually seen in single electron transfer (SET) reactions involving the formation of free radicals. However, in PTC reactions following the ionic mechanism, rate enhancements are typically due to mechanical effects, mainly through an enhancement in mass transfer. In LLPTC systems, cavitation collapse near the liquid-liquid interface disrupts the interface and impels jets of one liquid into the other, forming fine emulsions, and leading to a dramatic increase in interfacial contact area across which transfer of species can take place. On the other hand, in SLPTC systems the implosion of the cavitation bubbles and the concurrent phenomenon of microstreaming of solvent jets onto the solid surface can also lead to fragmentation of the solid particles, increasing the area available for mass transfer. Sonication also sweeps away reactive intermediates and products from the solid surface, renewing the surface for reaction. Ultrasound also creates a turbulent boundary layer near the solid surface, thereby reducing the film thickness and enhancing mass transport across the solid-liquid interface. We believe that ultrasound can also perform a function similar to that of traces of water in an SLPTC system by weakening the crystal lattice structure of the solid reagent, and, thereby enabling the PT catalyst to easily ion exchange at the solid surface.

It has been reported that a combination of PTC and ultrasound is often better than either of the two techniques alone (Davidson et al., 1983; Jouglet et al., 1991). In such cases, the PT catalyst initiates the reaction by the transfer of species

Table 4. Combinations of PTC with Other Rate Enhancement Techniques

Combination of PTC with	Illustrative Example	Reference
Ultrasound	Michael addition involving the addition of chalcone to diethyl malonate in SLPTC mode.	Ratoarinoro et al. (1992) Contamine et al. (1994) Hagenson et al. (1994)
	Synthesis of benzyl sulfide by reaction of solid sodium sulfide with benzyl chloride.	Davidson et al. (1987)
	Esterifications, etherification and hydrolysis of esters.	Jougllet et al. (1991)
	Michael reaction involving nitroalkanes with monosubstituted <i>a, p</i> -unsaturated esters.	Galín et al. (1987)
	<i>N</i> -alkylation of indene, <i>N</i> - <i>N</i> -diazocoronands, and amines. Synthesis of fulvenene from phenylacetylene.	Wang and Zhao (1996)
Microwaves	Alkylation of ethylphenyl sulfonyl acetate, diethyl malonate, anions derived from active methylene.	Wang and Jiang (1992), Wang et al. (1995)
	Dihalocyclopropanation of substituted olefins under LLPTC and SLPTC conditions.	Villemin and Labiad (1992)
	Ethoxylation of <i>o,p</i> -nitrochlorobenzene. Base catalyzed (soluble base, solid K_2CO_3 or bases impregnated on alumina) synthesis of esters.	Yuan et al. (1992a) Loupy et al. (1993)
	Reaction of carboxylic acids with halides.	Yuan et al. (1992b)
Microphases	Synthesis of benzyl sulfide by reaction of solid sodium sulfide with benzyl chloride.	Hagenson et al. (1994)
Electra-organic synthesis	Chlorination of substituted naphthalenes.	Forsyth et al. (1987)
	Toluene and aromatic hydrocarbon oxidation using Ce^{4+}/Ce^{3+} as a redox mediator.	Pletcher & Valdez (1988a,b)
	Anthracene oxidation to anthraquinone using Mn^{3+}/Mn^{2+} as the redox mediator.	Chou et al. (1992)
Photochemistry	Photocyanation of aromatic hydrocarbons.	Beugelmans et al. (1978)
	Photochemically induced polymerization of methyl methacrylate.	Shimada et al. (1989, 1990)
	Reduction of nitrobenzenes to the corresponding oximes or quinones using viologens.	Tomioka et al. (1986)
	PTC carbonylation of aryl and vinyl halides under UV irradiation.	Brunet et al. (1983)
Metal co-catalyst	Photohydrogenation of acetylenic groups with viologen, Pt or Pd, and a photosensitizer.	Maidan and Willner (1986)
	Cyclooligomerization of alkynes with $RhCl_3$ as cocatalyst.	Amer et al. (1990)
	Carbonylation reactions with Pd based complexes or cobalt carbonyl as cocatalyst.	Alper (1988)
	Hydrogenolysis of aryl bromides by aqueous sodium formate with Pd complex as cocatalyst.	Bar et al. (1982)
	Selective hydrogenation of α, β -unsaturated carbonyl compounds using rhodium trichloride and Aliquat 336.	Azran et al. (1986)
	Hydrogenolysis of bromoanisoles with sodium formate, Pd/C, and cyclodextrins as inverse Pt catalysts.	Shimuzu et al. (1990)
	Carbonylation of α -hydroxyalkynes catalyzed by NiCN and a PT catalyst.	Arzoumanian et al. (1992)

across the interface and ultrasound merely facilitates this transfer, possibly by increasing the interfacial area across which this transfer occurs. On the other hand, ultrasound by itself has been suggested as an alternative to PTC in a number of reactions (Regen and Singh, 1982; Mason et al., 1990). Ultrasound with basic alumina as a catalyst has been found to be a good substitute for PTC also (Ando et al., 1984; Hanasufa et al., 1987; Pradhan and Sharma, 1992).

The use of ultrasound is found to alter the reaction pathway and selectivity ratio in some cases. For reactions where reagents may react either by an ionic or a free radical pathway, ultrasound prefers the latter at the expense of the ionic pathway (Einhorn et al., 1990; Ando and Kimura, 1990; Luche et al., 1990). Neumann and Sasson (1985b) reported the use

of ultrasound with PEG400 as the PT catalyst for the autooxidation of 4-nitrotoluene in the presence of oxygen and KOH. While mechanical agitation gave only the dimeric product, *p*-nitrobenzoic acid was obtained in the presence of ultrasound irradiation. Contamine et al. (1994) found that in the PT catalyzed Michael addition of chalcone on diethyl malonate in a solid-liquid system the reaction was activated not only through an increase in interfacial area, but also through the acceleration of a radical step. Thus, both mechanical and chemical effects can be seen in some PT catalyzed reactions.

However, commercial feasibility of ultrasound depends on the development of novel reactors that can tap its great potential. Mason (1992) and Berlan and Mason (1992) describe several types of large-scale sonochemical reactors and ad-

dress key issues in the scale-up for successful sonochemical reactions. These general principles might need further analysis and modifications in the case of heterogeneous PT catalytic systems.

Use of microphase in PTC systems

Microphases have been found to enhance the rate of reactions in heterogeneous systems due to their ability to facilitate the transport of reagents across interfacial boundaries. Microphases are usually particles, bubbles, or droplets that are smaller than the diffusion length of the solute. The microphase physically lifts the reactive anion, or in some cases adsorbs it from the diffusion film, and transports it into the organic bulk where reaction ensues (Mehra, 1990). In the only article of its kind, Hagenson et al. (1994) reported a combination of PTC, microphase, and ultrasound in the synthesis of benzyl sulfide in a solid-liquid system. Their results (Figure 16) showed that for the given system, while PTC has the dominant effect, both microphase (fumed silica) and ultrasound lead to an additional enhancement when used with PTC (although their individual effects are minimal). Also, it was shown that a wrong choice of microphase (silica gel in this case) could lead to a suppression of the PT catalytic effect. Thus, addition of a microphase is not necessarily beneficial in PTC systems and a proper choice of microphase is crucial.

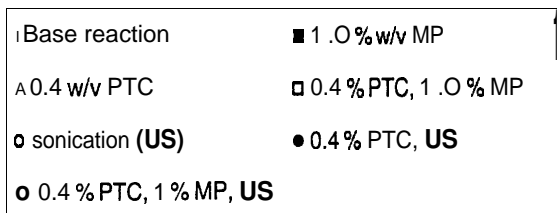
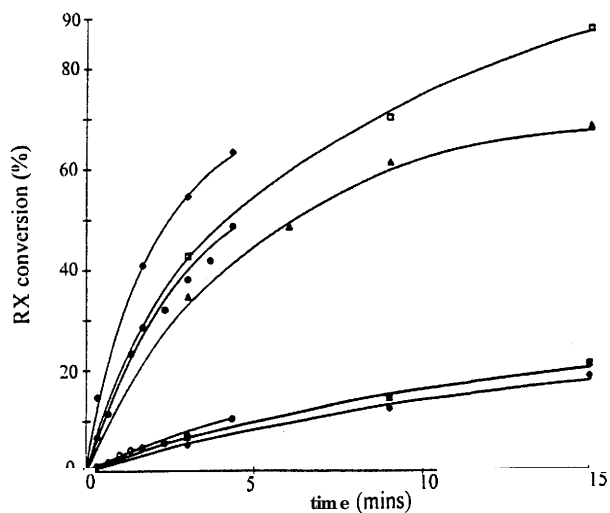

Figure 16. Effect of ultrasound and microphases in a solid-liquid PTC system.

Adapted from Hagenson et al. (1994).

Microwave enhancement in PTC systems

The use of microwaves in organic synthesis is more recent as compared to that of ultrasound. However, a number of studies have recently been reported involving the use of microwave irradiation in PTC systems (see Table 4). Reaction in the presence of microwave irradiation is observed to be extremely fast (usually completed under ten minutes) and requires only a simple standard nonmodified microwave oven (for laboratory-scale applications). Due to the fast and easy reaction involved, a large number of attempts to try microwave irradiation in PTC systems is expected. For example, in the synthesis of esters in dry media (no organic solvent), the use of microwave irradiation obviated the use of high pressures and the use of an organic solvent (Loupy et al., 1993). Also, the yields were further improved due to the displacement of equilibria by removal of volatile polar molecules like water or light alcohols due to microwave absorption. Under microwave conditions, the most volatile component, methyl alcohol was easily removed by microwave evaporation. Thus, complex methods, like azeotropic distillation, addition of molecular sieves or the use of partial vacuum under dry conditions, to shift the equilibrium are not needed. However, in carrying out reactions under microwave irradiation one cause for concern is the possibility of a reaction runaway due to high final temperatures and pressures reached within the reactor. The commercial feasibility of microwaves depends on factors such as the decomposition of the PT catalyst under the high temperatures and pressures reached with microwave heating, kinetic and mechanistic aspects of the reactions, and the development of novel reactors to enable scale-up to industrial level operation (Raner et al., 1995; Cablewski et al., 1994; Constable et al., 1992; Chemat et al., 1996).

Photoexcitation in PTC systems

Some recent articles have reported the use of PTC in photochemically excited reaction systems. For example, Guarini and Tundo (1987) reported the use of silica bound phosphonium salts and pyridinium salts in the photooxidation of organic substrates with singlet oxygen in the presence of Rose Bengal. Since the sensitizer is present in the aqueous phase, no reaction is observed in the absence of the PT catalyst, whereas in the presence of the PT catalyst the Rose Bengal anion is transferred to the organic phase. Some other typical reactions involving photoexcitation in PTC systems are given in Table 4.

PTC in electroorganic synthesis

The use of PT catalysts in electroorganic oxidation and reduction reactions in two-phase systems is widespread, since it involves *in-situ* generation and regeneration of oxidizing and reducing agents. Some applications in two-phase chlorinations, cyanations, and acetoxylation are also reported. Most applications of PTC in electroorganic synthesis are reported for liquid-liquid systems. In a rare instance of a solid-liquid PTC reaction in electroorganic synthesis, Chou et al. (1992) reported the indirect oxidation of solid anthracene in aqueous solution, using Mn^{2+}/Mn^{3+} redox mediators and a PT catalyst.

Oxidations are usually carried out using ionic couples, like Ce^{3+}/Ce^{4+} , Mn^{2+}/Mn^{3+} , Co^{2+}/Co^{3+} and Cl^-/ClO^- , as redox mediators or oxygen carriers. The ions are oxidized anodically and then used as oxidants in converting the organic substrate to the desired product. The anodic regeneration of the ions to the higher oxidation state takes place in the aqueous phase, and thus the oxidant ions have to be transported to the organic phase for the desired oxidation reaction to take place. In the absence of a PT catalyst, the reaction is slow and low selectivity is obtained since the organic substrate has to dissolve in the electrolyte or reaction has to occur at the boundary between the two phases. The interphase shuttling of the redox mediators plays a very important role in the oxidation of the organic substrate. The addition of a PT catalyst significantly increases the mass transfer of the redox mediator between the aqueous and organic phases.

Recently, Do and coworkers have extensively studied the electrochemical oxidation of benzyl alcohol in an aqueous-organic emulsion phase in the presence of a PT catalyst (soluble and immobilized) and Cl^-/ClO^- in batch (Do and Chou, 1989, 1990, 1992) and continuous (Do and Do, 1994a-c) electrochemical reactors. Besides studying the various factors affecting the current efficiency, a detailed mathematical model has been developed for this system in these articles, accounting for the kinetics and mechanism of the reaction.

Nontypical Applications of PTC

Inverse PTC

Mathias and Vaidya (1986) reported a class of heterogeneous reactions similar to PTC systems, which they called **inverse phase transfer catalysis** (IPTC), where the phase-transfer agent transfer species from the organic phase to the aqueous phase, and the main reaction occurs in the aqueous phase. Since then, a large number of reaction systems involving IPTC have been reported. Commonly used inverse PT catalysts include 4-diaminopyridine based compounds, pyridine, and pyridine-N-oxides, and different cyclodextrin derivatives. The pyridine based compounds function essentially through a reaction intermediate (Wamser and Yates, 1989; Wang et al., 1994; Fife and Xin, 1987). On the other hand, cyclodextrins, which are cyclic oligomers of glucose with a lipophilic interior and a hydrophilic exterior, solubilize organic substances by forming host-guest complexes within the interior of the cyclodextrin structure (Trifonov and Nikiforov, 1984; Trotta, 1993). Thus, while pyridinium based compounds function like quats do in normal PTC, cyclodextrin compounds behave like host molecules (such as crown ethers and cryptands) and transport the entire molecule into the other phase.

In addition to pyridinium based catalysts and cyclodextrin derivatives, some special compounds have also been reported to be useful inverse PT catalysts for specific reactions. Tetramethyl ammonium salts that are ineffective as PT catalysts due to their high solubility in the aqueous phase have been found to be effective inverse PT catalysts in some systems. Some metal compounds like platinum, palladium, and rhodium can strongly complex with water-soluble ligands such as the trisodium salt of triphenylphosphine trisulfonic acid, and act as effective inverse PT catalysts. These complexes are soluble in the aqueous phase only and, thus are easily recov-

ered and recycled, with the organic product extracted back into the organic phase after reaction.

Electron transfer and free radical processes

Most PTC reactions follow an ionic mechanism. However, Goldberg (1992) has reviewed a large number of applications of PTC involving electron transfer across the interface for organic synthesis. For example, radical intermediates are possible in some transition metal complex catalyzed PTC reactions, PTC reactions involving diazonium salts, oxidations by potassium superoxide, epoxidations and chlorinations of hydrocarbons, free-radical polymerizations, and the oxidative coupling of phenols. An important class of reactions involves the use of viologens (oil-soluble pyridinium based salts), which are effective electron acceptors and carriers, useful in assisting the interphase transport of electrons. For best results, a combination of PTC and ultrasound can possibly be tried in many of these reactions, since they involve single electron transfer or free radical intermediates.

PTC in electrophilic substitution reactions

The vast literature on applications of PTC in substitution reactions is mainly restricted to nucleophilic substitution reactions with an anionic reagent. However, recently the use of PTC in electrophilic reactions, like diazotization and azo coupling *in-situ*, C- and N-nitrosation, C-alkylation, acid hydrolysis of esters, chloromethylation, nitrite-initiated nitrations, and so on have been reported (Velichko et al., 1992; Kachurin et al., 1995). Alkylbenzene sulfonates and lipophilic sodium tetrakis[3,5-bis(trifluoromethyl)phenyl]boronate are typical electrophilic PT catalysts. Lipophilic dipolar molecules of the betaine type and zwitterionic compounds also function well as PT agents for both nucleophilic as well as electrophilic reactions.

PTC in a supercritical fluid (SCF-PTC)

In a recent article, the first of its kind, Dillow et al. (1996) reported a PT catalytic reaction carried out in a supercritical fluid (SCF). In this study, the two phases involved in the reaction were supercritical carbon dioxide and a solid phase. The use of environmentally benign supercritical carbon dioxide facilitates solvent removal as it is easily separated from reaction products by depressurization. Also, liquid-like densities with gas-like diffusivities and viscosities ensure high rates of mass transfer, making SCF-PTC very attractive for mass-transfer controlled reactions. The mechanism of the PTC cycle is similar to the traditional PTC mechanism and involves transfer of the reactant anion from the solid phase to the supercritical fluid by a quaternary onium salt or a macrocyclic multidentate ligand such as a crown ether. The choice of catalyst is, however, restricted in this case by its solubility in the SCF phase. A polar or protic cosolvent like acetone is necessary to enhance the solubility of the catalyst in the SCF phase. Even small amounts of acetone greatly increase the solubility of the catalyst with solute solubility decreasing with an isobaric increase in temperature due to the dominating effect of solvent density on solubility. Thus, compared to traditional PTC, which usually requires large amounts of organic solvents, SCF-PTC requires relatively much lower

amounts of solvent. Further studies are necessary to completely understand the various controlling factors in a SCF-PTC system, so as to be able to tap the full potential of this important advance in PTC technology.

PTC in the industry

PTC finds its widest applications in the synthesis of intermediates in the fine chemicals (agro-chemicals, pharmaceutical, dyes, paper, and so on) industries (Lindbloom and Elander, 1980; Reuben and Sjoberg, 1981; Freedman, 1986; Starks, 1990; Sharma, 1997). We summarize some typical representative industrially important reactions in Table 5. It should be noted that it is not our intention to review the hundreds of articles that report the use of PTC in industrially important reactions, and these are only illustrative examples.

Process Development for PTC Reactions

Considerations in process design and scale-up

Effective utilization of raw materials (high yields), increased selectivities (in some cases), mild and clean conditions of reaction, and high reaction rates are some of the features that make PTC very feasible for industrial adaptation. However, despite a vast amount of literature on organic syntheses using PTC, little information is available on the commercialization and scale-up for these reactions. The applications of PTC in industrial processes have not been described in the open literature. Most scale-up and process development schemes remain patented or hidden secrets. Specific process steps and technology for these reactions, as part of an overall manufacturing process in fine chemical synthesis, need to be analyzed. It should be noted that specific

Table 5. Selected Examples of Some Industrially Important Reactions

Application	Reaction	Reference
<i>Chiral synthesis using cinchidinium derived optically active PT catalyst</i>		
• Synthesis of indacrinone, a diuretic drug candidate	C-alkylation of indanone derivatives and oxindoles using cinchoma alkaloids.	Dolling et al. (1987) Bhattacharya et al. (1986)
* Synthesis of chiral α -amino acids	Alkylation of imines , glycine derivatives, and Schiff base derivatives.	O'Donnell (1993) O'Donnell et al. (1989)
<i>Polymerization reactions</i>		
* Condensation reactions	Synthesis of polycarbonates, polyester, polysulfonates, and polyethers.	Tagle et al. (1994) Leung et al. (1994)
† Free radical polymerizations	Polymerization of acrylonitrile using potassium peroxomonosulfate as initiator.	Balakrisnan and Arivalagan (1994)
* Anionic polymerizations	Diene polymerization in the presence of crown ethers.	Reetz and Ostarek (1988) Cheng (1984)
* Chemical modification of polymers	Modifications of chloromethyl substituted polystyrene and poly(vinyl halides) .	Frechet (1984)
<i>Agrochemicals</i>		
• Synthesis of an antidote for herbicides	N-alkylation of hexamethylenetetraamine with chloromethyl ketones.	Smith (1990)
* Synthesis of herbicides and insecticides	Selective O-alkylation and O-phosphorylation of ambient pyridinates.	Cutie and Halpern (1992)
* Synthesis of insecticidal pyrethroid and insect pheromones	Wittig reaction of aliphatic aldehydes and alkenyl alcohols with 50% NaOH or solid K_2CO_3 .	Deng et al. (1989)
* Synthesis of naturally occurring pellitorine, possessing insecticidal activity	PTC vinylation of (E)-1-iodo-1-heptene with vinyl acetate.	Jeffrey (1988)
† Synthesis of a herbicide	N-alkylation of substituted phenyl N-hydroxyurea with dimethylsulfate.	Fujita et al. (1982)
* Synthesis of an intermediate for the preparation of insecticidal pyrethroids	PTC Wittig reaction of trans-caronaldehyde ethyl ester with 50% NaOH and an in-situ-generated PT catalyst.	Galli et al. (1984)
<i>Perfumery and Fragrance Industry</i>		
* Enhancement and augmentation of aroma of perfumes	Alkylation of acetophenone moiety with allyl chloride.	Sprecker and Hanna (1982)
* Intermediate step in the synthesis of a fragrance from furfural	C-alkylation of propanal and butanal by 2-chloromethylfuran.	Norwicki and Gora (1991)
@ Synthesis of phenylacetic acid, an intermediate in the perfumery industry	Carbonylation of benzyl chloride in the presence of a palladium based catalyst.	Cassar et al. (1976)
<i>Compounds with Biological Activity</i>		
* One-pot synthesis of carboxamides and peptides	Reaction of a free acid or a carboxylic ester with an amine with KOH/ K_2CO_3 and a phenylphosphonate coupling agent.	Watanabe and Mukiyama (1981a)
* Synthesis of intermediates in nucleic acid chemistry	Regioselective synthesis of p-toluenesulfonyl derivatives of carbohydrates and nucleosides.	Grouiller et al. (1987)
• One-pot synthesis of benzofuran derivatives, with wide ranging biological activities	Reaction of <i>o</i> -chloronitrobenzenes with sodium azide.	Ayyangar et al. (1987)
* Synthesis of aminopyrroles, intermediates in synthesis of biologically active compounds like pyrrolyhriazenes	N-alkylation of N-unsubstituted 3-aminopyrrole with TDA-1 as PT catalyst.	Almerico et al. (1989)

Table 5. Selected Examples of Some Industrially Important Reactions(Continued)

Application	Reaction	Reference
Pharmaceuticals		
<ul style="list-style-type: none"> †Synthesis of various drugs like dicyclonine, phenoperidine, oxaladine, ritaline, etc. •Synthesis of (R)-fluorenyloxyacetic acid, useful in the treatment of brain edema 	<ul style="list-style-type: none"> Alkylation of phenylacetonitrile using NaOH, instead of expensive sodium ethoxide. Use of a nonionic surfactant, Triton X, with a cinchonidinium based PT catalyst to accelerate the alkylation step. 	<ul style="list-style-type: none"> Lindbloom and Elander (1980) Dolling (1986)
*Synthesis of commercial antibiotic, chloramphenicol	Aldol condensation in the presence of NaOH and a PT catalyst.	Koch and Magni (1985)
*Synthesis of penicillin based compounds (Astra AB, Sweden)	Selective esterification of benzylpenicillin using α -chloroethylcarbonate.	Lindblom and Elander (1980)
•Synthesis of chlorpromaine and imipramine, an antidepressant	N-alkylation of carbazones, phenothiazines, acridanone, and indoles using alkyl halides and aqueous NaOH/solid K_2CO_3 .	Schmolka and Zimmer (1984)
•Synthesis of lysergic acid based pharmaceuticals* and other molecules with the indole skeleton	Facile and selective monoalkylation of the indole nitrogen using PTC, instead of using K-azide in liquid ammonia at $-40^\circ C$.	Lindblom and Elander (1980)
†Synthesis of calcitriol derivatives	O-alkylation using ter-butylbromoacetate.	Neef and Steinmeyer (1991)
*Synthesis of drugs and pharmacologically active agents	N-alkylation of phenothiazines, carboamides, and β -lactams.	Masse (1977)
Other Specialty Chemicals		
@Synthesis of chlorprene	Dehydrohalogenation of 3,4-dichlorbut-1-ene.	Maurin (1983)
•Synthesis of allyltribromophenol, a flame retardant polymer	Etherification of hindered tribromophenol with allyl bromide	Wang and Yang (1990)
•Synthesis of prepolymers based on natural resources like lignin	Reaction of hydroxylalkyl modified lignin with epichlorohydrin and solid KOH.	Glasser et al. (1990)
•Synthesis of dialkyl sulfides (additives for lubricants, stabilizers for photographic emulsions)	Reaction of sodium sulfide with benzyl chloride.	Pradhan and Sharma (1992) Hagenson et al. (1994)
•Synthesis of spiro derivatives of tetrahydrothipene, a characteristic fragment of many alkaloids	Spiro-linking of tetrahydrothipene ring to a substituted quinolizidine skeleton.	Wrobel and Hejchman (1987)
†Synthesis of β -lactams	Reaction of amino acids and methanesulfonyl chloride.	Watanabe and Mukiyama (1981b)
*Synthesis of dichlorovinyl carbazole, used in preparation of photoconductive polymers	Dichlorovinylatation of carbazole in solid-liquid system.	Pielichowski and Czub (1995)
†Synthesis of macrolides like lactones	Synthesis of lactones from the conjugate base of ω -bromo carboxylic acids.	Kimura and Regen (1983b)
*Synthesis of dyes derived from desyl esters	Reaction of desyl alcohol with NaOH, chloroform and a PT catalyst, followed by a PEG catalyzed chloride displacement.	Shenoy and Rangnekar (1989)

guidelines about choice of catalyst, mode of operation, use of co-catalyst or other enhancement techniques with the PT catalyst, and so on cannot be set up due to the wide variety of reaction types possible in PTC systems. Some general empirical guidelines for the choice of catalyst, reaction conditions, choice of reagent (anion), and so on have been discussed in the existing literature.

So far, much research has gone into finding new synthetic routes, new products and novel selective syntheses, and in the analysis of important factors affecting yield and in some cases selectivity. However, other practical constraints relevant to process development for industrial-scale synthesis have to be tackled. For example, new insights are needed to develop cost-effective, stable, and selective PT catalysts (especially effective immobilized triphase catalysts). Other relevant factors include the recovery and recycle of the PT catalyst, catalyst decomposition, environmental issues such as catalyst toxicity, and ease of product recovery. Catalyst costs are not very high when quats are used, as against the more expensive crown ethers or cryptands. In most cases, the overall process is more than cost-effective since PTC allows the use of cheap alternative raw materials, prevents the use of costly dipolar solvents, is less energy intensive (due to lower temperatures) than alternative methods, alleviates the need

for special conditions, is safe and environmentally clean, and also gives much higher yields and sometimes higher selectivities than otherwise possible. The byproduct output of a PTC process is usually low, since the desired reaction is phase transfer catalyzed and other side reactions, if any, are non-catalyzed. High product purity (which is crucial in the pharmaceutical and specialty chemicals industries) is, thus an added bonus in PTC systems. The flexibility in choice of organic solvent is a key advantage in PT catalyzed reactions, since it eliminates the requirement for costly, toxic, and difficult to recover dipolar aprotic solvents like DMF or DMSO. In some cases (Bram and Sansoulet, 1985), the total elimination of the organic solvent is also proposed, eliminating the solvent handling, recovery, and related environmental problems, and leads to larger batch size for a given reactor size, reduced energy consumptions (no solvent recovery and purification steps), and faster reactions with the neat organic substrates. This alternative should always be considered as an option, especially in solid-liquid systems.

Separation of the soluble PT catalyst from the reaction mixture is usually a detailed process. However, it is becoming more and more crucial to develop technology to recover and reuse the PT catalysts due to increasing costs of the catalysts, as well as environmental concerns regarding the toxicity

of quats and crown ethers in effluent streams from these processes. Since the use of triphase catalysts (which would ensure ease of separation and recycle of the supported PT catalysts) is minimal in the industry, methods of recovery of soluble PT catalysts from the reaction mixture have to be sought (Zaidman et al., 1985). Although none of these are widely discussed in the open literature, Starks et al. (1994) summarize three main techniques of PT catalyst separation.

Extraction of the PT catalyst into water is the commonly used technique for PT catalysts that are soluble in water. Incineration of the extracted PT catalysts is the preferred method of disposal, though oxidation in biooxidation ponds dedicated to PTC processes is justified in some cases. Water effluent treatment is important as quats and crown ethers are toxic for marine life.

Distillation of product overhead, with the PT catalyst remaining in the residue, is a feasible technique for catalyst separation for water insoluble PT catalysts with distillable products. Here, decomposition of volatile quats to the corresponding amines or alkenes is possible, although capped PEGs are easily separated by distillation.

For products that are not distillable and PT catalysts that are not water insoluble, adsorption of the quats on silica or ion exchange resins can be tried with the catalyst recoverable by elution with a well chosen polar solvent.

Reactor choice

Process development for a PT catalyzed system involves not only a consideration of the guidelines for appropriate choice of reagents, reaction conditions, and post-reaction recovery stages but also the incorporation and optimization of reaction kinetics for good reactor design. Most PTC reactions are carried out on an industrial scale in the batch mode in mixer-settler arrangements. However, operation in the continuous mode is also possible in some cases. For example, Ragaini et al. (1986, 1988, 1990) reported the use of fixed-bed reactor with a bed of triphase catalyst with mixing by ultrasonic mixers as well as turbine stirrers. Similarly, Tundo et al. (1988, 1989) used a fixed-bed reactor with a reactive solid bed for gas-solid PTC, whereas Stanley and Quinn (1987) reported, perhaps the only study in which a membrane reactor (operated in the continuous mode) was used. Recently, Do and Do (1994a-c) have reported a detailed modeling and kinetic study of the electrochemical oxidation of benzyl alcohol to benzaldehyde in a continuous-stirred tank electrochemical reactor.

Possible reactor choices and qualitative descriptions of how to choose the right reactor for fine chemicals synthesis are discussed in an extensive review (Mills et al., 1992). These guidelines can be adapted, with minor modifications, to process design and development for PTC reactions. A proper understanding of the mechanism and kinetics of the reaction involved is useful in reanalyzing and modifying these guidelines to suit particular characteristics of PTC reactions. For example, high inter-facial area with little emulsification of phases and ease of phase separation are necessary requisites for a liquid-liquid contactor for PTC reactions. Traditionally, LLPTC reactions are carried out in simple mixer-settler arrangements. For triphase reactions in liquid-liquid systems, where the catalyst is a solid phase, either a packed bed or a

slurry reactor can be used. For fine chemical synthesis where reactor yield per unit volume of reactor is not a very crucial factor and total tonnage of synthesis is also often low, a slurry reactor can function very well for both liquid-liquid-solid and gas-liquid-solid (GLPTC) systems.

The membrane reactor has a number of advantages over traditional mixer-settlers like ease of phase separation without emulsification, high surface area per unit volume of reactor, and so on. However, Stanley and Quinn (1987) remains the only article to date that reports the use of a membrane reactor for a PTC reaction. It should be noted that even this article did not tap the ability of the membrane to serve as a selective separation medium. The membrane merely served to localize the aqueous/organic interface and to avoid problems like emulsification of the phases during separation. We believe that future research should be directed towards the use of a membrane module as a combination reactor and separator unit with the membrane serving not merely to carry out the PTC reaction, but also to simultaneously and selectively recover the organic product. Recently, various reports on the use of hollow fiber membrane contactors for the extraction of heavy metal ions and organic solutes like phenols from aqueous wastewater streams using quaternary ammonium salts have been published (Alonso et al., 1994; Daiminger et al., 1996). Although these do not classify explicitly as PTC reactions, the process involves carrier-mediated transport of the solute through the membrane into the organic solution on the other side of the membrane wall. A novel extension of these principles would be to use a hydrophobic membrane with the quaternary ammonium salt immobilized on the membrane, thereby tapping the advantages of a membrane reactor while ensuring few or no catalyst recovery, separation, and product contamination problems. Since high interfacial areas per unit volume of the reactor are possible in the membrane reactor, thus ensuring rapid mass transfer, the membrane module can serve as an effective reactor for synthesis of high value, medium to low volume specialty chemicals. However, considerably more work is required to study the feasibility of membrane reactors for PTC systems.

Conclusions

In recent years, a lot of research has gone into developing new techniques for reaction rate enhancement. Usually, these techniques are more chemistry-intensive than what traditionally chemical engineers have been used to. A part of the future of chemical engineering lies in our ability to keep pace with these developments and bring to bear on them the impact of an engineering science approach. One of the authors (Doraiswamy, 1987) has held the view that there should be a better balance between chemistry and chemical engineering science in order to be able to better exploit any process, and also exploit processes that might have been shelved "unexploitable." The present review provides a practical example of the potential of such an approach in industrial organic synthesis.

In the review presented above, we have highlighted the various aspects of PTC. Clearly, over 95% of the publications are chemistry-based and it is only in the last few years that chemical engineers have begun to make inroads into thie-

citing field. The present review has thus concentrated on the methods of modeling PTC reactions, using both soluble and immobilized forms of the catalyst. By its very nature, PTC involves interphase transport of species, neglecting which can grossly overpredict the conversion of a PTC mediated reaction. An outline of the various combinations of PTC with other rate enhancing techniques clearly highlights the need for an engineering analysis for these combinations also.

The separation of soluble PTC is a matter of concern in the industry not only due to environmental considerations, but also due to contamination of the product with the catalyst. Further research should be oriented towards development of novel catalyst separation techniques and of novel reactor-separator "combo" units. As outlined before, the development of a membrane reactor with PTC catalyst immobilized on the membrane surface seems to be a novel and viable candidate for accomplishing PTC reactions on an industrial scale. Another aspect of PTC which needs urgent consideration is the development of engineering technology for immobilized PTC. This would require the development of supports with low diffusional limitations and with the right hydrophilic-lipophilic balance to ensure adequate contact of the aqueous and organic phases with the supported catalyst.

It is hoped that this review will spur engineering based research in this area, whose applications in the manufacture of organic intermediates and fine chemicals seem almost unlimited.

Notation

- a = interfacial area, m^2/m^2
 Bi_m = Biot number for mass transfer
 C_i = concentration of species i , $kmol/m^3$
 D_i = liquid-phase diffusivity, m^2/s
 D_e = effective diffusivity within solid or catalyst phase, m^2/s
 Da = Damköhler number
 k_1 = forward rate constant for ion exchange, $m^3/kmol/s$
 k_{-1} = reverse rate constant for ion exchange, $m^3/kmol/s$
 k_2 = organic reaction rate constant, $m^3/kmol/s$
 k_{ti} = mass-transfer coefficient for species i , m/s
 k_{mn} = organic reaction n th order rate constant
 k_{si} = solid dissolution mass-transfer coefficient, m/s
 K = equilibrium constant for ion exchange
 K_i = dissociation constant for species i
 K_{QX} = interphase mass-transfer coefficient for species i , m/s
 m_i = distribution coefficient for quat between organic and aqueous phases
 \sqrt{M} = ratio of reaction in film to bulk, Table 2
 N_i = number of moles of species i , $kmol$
 q_0 = initial added quat, $kmol/m^3$
 R = radius of solid phase, m
 S = membrane surface area, m^2
 t = time, s
 V_a = volume of aqueous phase, m^3
 V_{cat} = volume of catalyst phase, m^3
 V_o = volume of organic phase, m^3
 $\alpha = Y_{aq}^-/X_{aq}^-$
 δ = film thickness
 ϵ_i = volume fraction of i phase in support pores
 ξ = location of reaction plane in regime 4
 ρ_c = density of solid support, kg/m^3
 ψ = parameter defined in Eqs. 20 and 21

Subscripts

- a, aq = aqueous
 b = bulk
 c = catalyst phase
 f = film

- int = interface
 o, org = organic
 s = solid
 si, so = inner and outer surface of membrane

Superscripts

- s = surface
 $*$ = saturation
 0 = initial time

Literature Cited

- AKelah, A., A. Rehab, A. Selim, and T. Agag, "Synthesis and Application of Organophilic Polystyrene-Montmorillonite Supported Onium Salts in Organic Reactions," *J. Mol. Catal.*, **94**, 311 (1994).
 Almerico, A. M., G. Cirrincione, E. Aiellio, and G. Daltolo, "About the Synthesis of N-1 Substituted 3-Aminopyrroles: A Comparison," *J. Heter. Chem.*, **26**, 1631 (1989).
 Alonso, A. I., A. M. Urriaga, A. Arabien, and M. I. Ortiz, "Extraction of Cr(VI) with Aliquat 336 in Hollow Fiber Contactors: Mass Transfer Analysis and Modeling," *Chem. Eng. Sci.*, **49**, 901 (1994).
 Alper, H., "Phase Transfer Catalysis in Organometallic Chemistry," *Adv. Organomet. Chem.*, **19**, 183 (1981).
 Alper, H., "Metal Catalyzed Carbonylation and Oxidation-Reduction Reactions," *Pure Appl. Chem.*, **60**, 35 (1988).
 Amer, I., T. Bernstein, M. Eisen, and J. Blum, "Oligomerization of Alkynes by the RhCl₃-Aliquat 336 Catalyst System: 1. Formation of Benzene Derivatives," *J. Mol. Catal.*, **60**, 313 (1990).
 Ando, T., T. Kawate, J. Yamakawi, and T. Hanafusa, "Acceleration of Solid-Liquid Two-Phase Reaction by Means of Alumina-Water-Ultrasound: A Substitute for a Phase Transfer Catalyst," *Chem. Lett.*, **725** (1984).
 Ando, T., and T. Kimura, "Reactivity and Selectivity in Organic Sonochemical Reactions Involving Inorganic Solids," *Ultrasonics*, **28**, 327 (1990).
 Angeletti, E., P. Tundo, P. Venturello, and F. Trotta, "Synthetic Opportunities of Gas-Liquid Phase-Transfer Catalysis," *British Polym. J.*, **16**, 219 (1984).
 Anelli, P. L., B. Czech, F. Montanari, and S. Quici, "Reaction Mechanism and Factors Influencing Phase-Transfer Catalytic Activity of Crown Ethers Bonded to a Polystyrene Matrix," *J. Amer. Chem. Soc.*, **100**, 881 (1984).
 Arrad, O., and Y. Sasson, "Thin Layer Phase Transfer Catalysis in the Reaction of Alkyl Chlorides and Solid Formate Salt," *J. Amer. Chem. Soc.*, **110**, 185 (1988).
 Arrad, O., and Y. Sasson, "Commercial Ion Exchange Resins as Catalysts in Solid-Solid-Liquid Reactions," *J. Org. Chem.*, **54**, 4493 (1989).
 Arrad, O., and Y. Sasson, "Silica Impregnated with Tetramethylammonium Salts as Solid-Solid-Liquid Triphase Catalysts," *J. Org. Chem.*, **55**, 2952 (1990).
 Arrad, O., and Y. Sasson, "Solid-Solid-Liquid Reaction Systems: A Mechanistic Study," *J. Chem. Soc., Perkin Trans.*, **2**, 457 (1991).
 Arzoumanian, H., and J. F. Petrigani, "Solid-Liquid Phase Transfer and Cobalt Catalyzed Synthesis of But-2-enolide," *Tetr. Lett.*, **27**, 5979 (1986).
 Arzoumanian, H., F. Cochini, D. Nuel, J. F. Petrigani, and N. Rogag, "Mono- and Dicarboxylation of α -Haloalkynes Catalyzed by Nickel Cyanide under Phase-Transfer Conditions," *Organomet.*, **11**, 493 (1992).
 Asai, S., H. Nakamura, and Y. Furuichi, "Distribution and Dissociation Equilibria of Phase Transfer Catalysts, Tricaprylmethyl Ammonium Chloride and Its Aqueous Phase Mass Transfer," *J. Chem. Eng. Jpn.*, **24**, 653 (1991).
 Asai, S., H. Nakamura, and Y. Furuichi, "Alkaline Hydrolysis of n-Butyl Acetate with Phase Transfer Catalyst Aliquat 336," *AIChE J.*, **38**, 397 (1992).
 Asai, S., H. Nakamura, M. Tanabe, and K. Sakamoto, "Distribution and Dissociation Equilibria of Phase Transfer Catalysts, Tetra-butyl Ammonium Salts," *Ind. Eng. Chem. Res.*, **32**, 1438 (1993).
 Asai, S., H. Nakamura, and T. Sumita, "Oxidation of Benzyl Alcohol Using Hypochlorite Ion via Phase-Transfer Catalysis," *AIChE J.*, **40**, 2028 (1994).

- Aserin, A., N. Garti, and Y. Sasson, "Preparation of Monoglycerides of Fatty Acids from Epichlorohydrin by Phase Transfer Catalysis. Glycidyl Esters," *Ind. Eng. Chem. Prod. Res. Dev.*, **23**, 452 (1984).
- Ayyanger, N. R., S. Madan Kumar, and K. V. Srinivasan, "Facile One-Pot Synthesis of 2,1,3-Benzoxadiazole *N*-Oxide (Benzofuroxan) Derivatives under Phase-Transfer Catalysis," *Synthesis*, **616** (1987).
- Azran, J., O. Buchman, I. Amer, and J. Blum, "Selective Hydrogenation of α,β -Unsaturated Carbonyl Compounds by Rhodium Trichloride and Aliquat 336 in a Two-Phase Liquid System," *J. Mol. Catal.*, **34**, 229 (1986).
- Balakrishnan, T., and K. Arivalagan, "Phase Transfer Catalyzed Free-Radical Polymerization of Acrylonitrile," *J. Poly. Sci., Part A: Poly. Chem.*, **32**, 1909 (1994).
- Balakrishnan, T., S. Hari Babu, and T. K. Shabeer, "Triphase Catalysis: II. Alkylation of Phenylacetone with 1-Bromobutane Catalyzed by Aqueous NaOH and Polystyrene-Supported Benzyltriethyl Ammonium Chloride," *J. Poly. Sci., Part A: Poly. Chem.*, **31**, 317 (1993).
- Balakrishnan, T., and J. P. Jayachandran, "New Multi-Site Phase Transfer Catalyst for the Addition of Dichlorocarbene to Styrene," *J. Chem. Soc. Perkin Trans.*, **2**, 2081 (1995b).
- Bar, R., Y. Sasson, and Y. Blum, "Hydrogenolysis of Aryl Bromides by Sodium Formate and Palladium-Phosphone Catalyst Under Phase Transfer Conditions," *J. Mol. Catal.*, **16**, 175 (1982).
- Bar, R., J. Zerda, and Y. Sasson, "Kinetics in Phase Transfer Catalysis: A Theoretical Study: 1. Poisoning Effect by Catalyst Foreign Ion," *J. Chem. Soc. Perkin Trans.*, **2**, 1875 (1984).
- Beugelmans, R., A. Ginsburg, A. Lecas, M. T. LeGoff, and G. Roussi, "Use of Phase Transfer Agents for Photocyanation of Aromatic Hydrocarbons," *Tetr. Lett.*, **3271** (1978).
- Berlan, J., and T. J. Mason, "Sonochemistry: From Research Laboratories to Industrial Plants," *Ultrasonics*, **30**, 203 (1992).
- Bhattacharya, V. A., U. Dolling, E. J. Grabowski, S. Krady, K. M. Ryan, and L. M. Weinstock, "Enantioselective Robinson Annulations via Phase Transfer Catalysis," *Angew. Chem., Int. Ed. Engl.*, **25**, 476 (1986).
- Bhattacharya, A., "General Kinetic Model for Liquid-Liquid Phase Transfer Catalyzed Reactions," *Ind. Eng. Chem. Res.*, **35**, 645 (1996).
- Bram, G. A., and J. Sansoulet, "Anionic Activation by Solid-Liquid PTC Without Solvents: Improvements in Organic Synthesis," *Israel J. Chem.*, **26**, 291 (1985).
- Brandstorm, A., "Principles of Phase Transfer Catalysis by Quaternary Ammonium Salts," *Adv. Phys. Org. Chem.*, **15**, 267 (1977).
- Brunelle, D. J., "Stable Catalysts for Phase Transfer at Elevated Temperatures," in *Phase-Transfer Catalysis: New Chemistry, Catalysts, and Applications*, C. M. Starks, ed., Amer. Chem. Soc. Symp. Ser. No. 326, p. 38 (1987).
- Brunet, J. J., C. Sidot, and P. Caubere, "Sun-Lamp Irradiated Phase-Transfer Catalysis: 1. Cobalt Carbonyl Catalyzed $S_{RN}1$ Carbonylation of Aryl and Vinyl Halides," *J. Org. Chem.*, **48**, 1166 (1983).
- Cablewski, T., A. F. Faux, and C. R. Strauss, "Development and Application of a Continuous Microwave Reactor for Organic Synthesis," *J. Org. Chem.*, **59**, 3408 (1994).
- Cassar, L., M. Foa, and A. Gardano, "The Use of Phase Transfer Catalysis in Palladium-Catalyzed Carbonylation of Organic Halides," *J. Organomet. Chem.*, **121**, C55 (1976).
- Chemat, F., M. Poux, J. L. Martino, and J. Berlan, "An Original Microwave-Ultrasound Combined Reactor Suitable for Organic Synthesis: Application to Pyrolysis and Esterification," *J. Microwave Power and Electromag. Energy*, **31**, 19 (1996).
- Chen, C. T., C. Hwang, and M. Y. Yeh, "Mathematical Modeling of a Liquid-Liquid Phase-Transfer Catalyzed Reaction System," *J. Chem. Eng. Jpn.*, **24**, 284 (1991).
- Cheng, T. C., "Anionic Polymerization: IX. A Review of the Use of Crown Ether as a Modifier in the Anionic Polymerization and Copolymerization of Diene," *Crown Ethers and Phase Transfer Catalysis in Polymer Science*, L. J. Mathias and C. E. Carraher, Jr., eds., Plenum Press, New York, p. 155 (1984).
- Chou, T. C., J. S. Do, and C. H. Cheng, "Using the Mediators/Phase Transfer Catalyst on the Anionic Oxidation of Organic Compounds," *Modern Methodology in Organic Synthesis*, T. Shono, ed., VCH, New York, p. 283 (1992).
- Choudhary, B. M., Y. V. S. Rao, and B. P. Prasad, "New Triphase Catalysts from Montmorillonite," *Clay and Clay Miner.*, **39**, 329 (1991).
- Constable, D., K. Raner, P. Somlo, and C. Strauss, "A New Microwave Reactor Suitable for Organic Synthesis and Kinetic Studies," *J. Microwave Power and Electromag. Energy*, **27**, 195 (1992).
- Contamine, F., F. Faid, A. M. Wilhelm, J. Berlan, and H. Delmas, "Chemical Reactions Under Ultrasound: Discrimination of Chemical and Physical Effects," *Chem. Eng. Sci.*, **49**, 5865 (1994).
- Cornelius, A., and P. Laszlo, "Clay Supported Reagents: II. Quaternary Ammonium Exchanged Montmorillonite as Catalyst in the Phase Transfer Preparation of Symmetric Formaldehyde Acetals," *Synthesis*, **162** (1982).
- Cutie, Z. G., and M. Halpern, "Process for Preparing Phosphothionates and Phosphonates in a Three-Phase System," DowElanco, U.S. Patent 5,120,846, Chem. Abstr. 117:90510c (1992).
- Daiminger, U. A., A. G. Geist, W. Nitsch, and P. K. Plucinski, "Efficiency of Hollow Fiber Modules for Nondispersive Chemical Extraction," *Ind. Eng. Chem. Res.*, **35**, 184 (1996).
- Davidson, R. S., A. Safdar, J. D. Spencer, and B. Robinson, "Applications of Ultrasound to Organic Chemistry," *Ultrasonics*, **25**, 35 (1987).
- Dehmlow, E. V., and S. S. Dehmlow, *Phase Transfer Catalysis*, 3rd ed., Verlag Chemie, Weinheim (1993).
- Dehmlow, E. V., R. Thieser, Y. Sasson, and Z. Pross, "The Extraction of Alkoxide Anions by Quaternary Ammonium PT Catalysis," *Tetr.*, **41**, 2927 (1985).
- Dehmlow, E. V., H. K. Raths, and H. Soufi, "Application of PTC Part 41: Cocatalytic Effects of Pinacol in Phase Transfer Catalysis," *J. Chem. Res. Synop.*, **334** (1988).
- Dehmlow, E. V., "Influence of Phase Transfer Catalyst Structure on Selectivity," *Russ. Chem. Bull.*, **44**, 1998 (1995).
- Deng, Y. N., H. D. Li, and H. S. Xu, "Synthesis of Insect Pheromones by Phase Transfer Catalytic Wittig Reaction," *Chin. Sci. Bull.* (CA 114: 23571y), **34**, 203 (1989).
- Desikan, S., and L. K. Doraiswamy, "The Diffusion-Reaction Problem in Triphase Catalysis," *Ind. Eng. Chem. Res.*, **34**, 3524 (1995).
- Dillow, A., S. L. Yun, D. Suleiman, D. L. Boatright, C. L. Liotta, and C. A. Eckert, "Kinetics of a Phase Transfer Catalysis Reaction in Supercritical Fluid Carbon Dioxide," *Ind. Eng. Chem. Res.*, **35**, 1801 (1996).
- Do, J. S., and T. C. Chou, "Anodic Oxidation of Benzyl Alcohol to Benzaldehyde in the Presence of Both Redox Mediator and Phase Transfer Catalyst," *J. Appl. Electrochem.*, **19**, 922 (1989).
- Do, J. S., and T. C. Chou, "Kinetics of the Anodic Oxidation of Benzyl Alcohol in Dichloromethane in the Presence of Both Redox Mediator and Phase Transfer Catalyst," *J. Appl. Electrochem.*, **20**, 978 (1990).
- Do, J. S., and T. C. Chou, "Anodic Oxidation of Benzyl Alcohol to Benzaldehyde in the Presence of Both Redox Mediator and Polymer-supported Phase Transfer Catalyst," *J. Appl. Electrochem.*, **22**, 966 (1992).
- Do, J. S., and Y. L. Do, "Indirect Anodic Oxidation of Benzyl Alcohol in the Presence of Phase-Transfer Catalyst in a CSTER: Effect of Flow Rate and Temperature," *Electrochimica Acta*, **39**, 2037 (1994).
- Do, J. S., and Y. L. Do, "Indirect Anodic Oxidation of Benzyl Alcohol in the Presence of Phase-Transfer Catalyst in a CSTER: Kinetics of Oxidation of Benzaldehyde and Effect of Concentration of Benzyl Alcohol," *Electrochimica Acta*, **39**, 2299 (1994).
- Do, J. S., and Y. L. Do, "Indirect Anodic Oxidation of Benzyl Alcohol in the Presence of Phase-Transfer Catalyst in a CSTER: Effect of Current Density, Organic-to-Aqueous Volume Ratio and Concentration of Phase-Transfer Catalyst," *Electrochimica Acta*, **39**, 2311 (1994).
- Dolling, U. H., "Use of an Achiral Co-Catalyst Promoter in a Chiral Phase Transfer Alkylation Process for Preparation of a Substituted Flurenlyoxyacetic Acid," U.S. Patent 4,605,761 (Chem. Abstr. 106:4697n) (1986).
- Dolling, U. H., D. L. Hughes, A. Bhattacharya, K. M. Ryan, S. Karady, L. M. Weinstock, V. J. Grenda, and E. J. Grabowski, "Efficient Asymmetric Alkylations via Chiral Phase-Transfer Catalysis: Applications and Mechanism," *Phase-Transfer Catalysis: New Chemistry, Catalysts, and Applications*, C. M. Starks, ed., ACS

- Symposium Series (326), American Chemical Society, Washington, DC, p. 67 (1987).
- Doraiswamy, L. K., and M. M. Sharma, *Heterogeneous Reactions, Analysis, Examples and Reactor Design*, Vol. II, Wiley, New York (1984).
- Doraiswamy, L. K., Olaf A. Hougen Lecture, University of Wisconsin, Madison, WI (1987).
- Dou, H. J. M., R. Gallo, P. Hassanaly, and J. Metzger, "Behavior and Stability of Catalysts in Bi- and Triphase Transfer Catalysis," *J. Org. Chem.*, **42**, 4275 (1977).
- Einhom, C., J. Einhom, and J. L. Luche, "Sonochemistry-The Use of Ultrasonic Waves in Synthetic Organic Chemistry," *Synthesis*, **11**, 787 (1989).
- Einhom, C., J. Einhom, M. J. Dickens, and J. L. Luche, "Organic Sonochemistry-Some Illustrative Examples of a New Fundamental Approach," *Tetr. Lett.*, **31**, 4129 (1990).
- Esikova, I. A., and S. S. Yufit, "Formation of Adsorption Complexes in Phase-Transfer Nucleophilic Substitution. Kinetic Analysis of Solid-Phase System," *J. Phys. Org. Chem.*, **4**, 149 (1991a).
- Esikova, I. A., and S. S. Yufit, "New Ideas on Phase Transfer Catalysts: SN₂ Reaction with a Solid Ionophoric Salt," *J. Phys. Org. Chem.*, **4**, 336 (1991b).
- Evans, K. J., and H. J. Palmer, "The Importance of Interphase Transport Resistances on Phase Transfer Catalyzed Reaction," *AIChE Symp. Ser.*, **77**(202), 104 (1981).
- Fife, W. C., and Y. Xin, "Inverse Phase Transfer Catalysis: Probing the Mechanism with Competitive Transacylation," *J. Amer. Chem. Soc.*, **109**, 1278 (1987).
- Ford, W. T., J. Lee, and M. Tomoi, "Mechanisms of Polymer-Supported Catalysis: 3. Ion Exchange Limitations and Macroporous Polystyrene Supports," *Macromolecules*, **15**, 1246 (1982).
- Ford, W. T., and M. Tomoi, "Polymer-Supported Phase Transfer Catalysts: Reaction Mechanisms," *Adv. Polym. Sci.*, **55**, 49 (1984).
- Forsyth, S. R., D. Pletcher, and K. P. Healy, "Electrosynthesis in Systems of Two Immiscible Liquids and a Phase Transfer Catalyst. VII: The Chlorination of Substituted Naphthalenes," *J. Appl. Electrochem.*, **17**, 905 (1987).
- Frechet, J. M. J., "Chemical Modification of Polymers via Phase Transfer Catalysis," in *Crown Ethers and Phase Transfer Catalysis in Polymer Science*, L. J. Mathias and C. E. Carraher, Jr., eds., Plenum Press, New York (1984).
- Freedman, H. H., "Industrial Applications of Phase Transfer Catalysis (PTC): Past, Present and Future," *Pure Appl. Chem.*, **58**, 857 (1986).
- Fujita, F., N. Itaya, H. Kishida, and I. Takemoto (Sumitomo Chemical Co. Ltd.), "Substituted Pheylurea," *Eur. Pat. Appl.* 3835 (Chem. Abstr. 92:110707t), U.S. Patent 4,328,166 (1982).
- Galin, F. Z., U. K. Ignatyuk, S. N. Lareev, and G. A. Tostikov, "Ultrasonic Excitation in the Alkylation of Indene," *J. Org. Chem. USSR*, **23**, 1214 (1987).
- Galli, R., L. Scaglioni, O. Palla, and F. Gozzo, "Synthesis of 2-Halogeno-Ethenyl Derivatives by Means of Wittig (Under Phase Transfer Conditions) or Wittig-Homer Reactions: Application in the Field of Pyrethroids," *Tetr.*, **40**, 1523 (1984).
- Glasser, W. G., W. DeOliveira, S. S. Kelly, and L. S. Nieh, "Preparation of Prepolymers from Hydroxyalkyl Lignin Derivatives," Center for Innovative Technology, U.S. Patent 4,918,167 (Chem. Abstr. 113:99698) (1990).
- Goldberg, Y., *Phase Transfer Catalysis, Selected Problems and Applications*, Gordon and Breach Science Publishers, Philadelphia (1992).
- Gordon, J. E., and R. E. Kutina, "On the Theory of Phase Transfer Catalysis," *J. Amer. Chem. Soc.*, **99**, 3903 (1977).
- Grouiller, A., H. Essadiq, B. Najib, and P. Moliere, "Regioselective o-p-Toluenesulfonylation of Nucleosides under Solid/Liquid Phase-Transfer Conditions," *Synthesis*, 1121 (1987).
- Guarini, A., and P. Tundo, "Rose Bengal Functionalized Phase-Transfer Catalysts Promoting Photooxidations with Singlet Oxygen. Nucleophilic Displacements on Dioxetanic and Endoperoxidic Intermediates," *J. Org. Chem.*, **52**, 3501 (1987).
- Hagenson, L. C., S. D. Naik, and L. K. Doraiswamy, "Rate Enhancements in a Solid-Liquid Reaction Using PTC, Microphase, Ultrasound and Combinations Thereof," *Chem. Eng. Sci.*, **49**, 4787 (1994).
- Halpem, M., Y. Zahalka, Y. Sasson, and M. Rabinovitz, "Hydroxide Ion Initiated Reactions Under Phase Transfer Catalysis Conditions: 9. Dehydrohalogenation of (haloethyl)benzenes by Quaternary Ammonium Salts," *J. Org. Chem.*, **50**, 5088 (1985).
- Hanasufa, T., J. Ichihara, and T. Ashida, "Useful Synthesis of α -Aminonitriles by Means of Alumina and Ultrasound," *Chem. Lett.*, 687 (1987).
- Herriot, A. W., and D. Picker, "Phase Transfer Catalysis: An Evaluation of Catalysts," *J. Amer. Chem. Soc.*, **97**, 2345 (1975).
- Hradil, J., and F. Svec, "Phase Transfer Catalysis: 2. The Reaction between Phenol and n-Butyl Bromide Catalyzed with Polyethyleneglycols Fixed on Macroporous Glycidylmethacrylate Copolymers," *Poly. Bull.*, **11**, 159 (1984).
- Hradil, J., F. Svec, and J. M. J. Frechet, "Mechanism of Phase-Transfer Catalysis Using Glycidyl Methacrylate-Ethylene Dimethacrylate Copolymers Modified with Tributylammonium Groups in Nucleophilic Displacement Reactions," *Polymer*, **28**, 1593 (1987).
- Hradil, J., F. Svec, C. Konak, and K. Jurek, "Localization of Reaction Sites in Supported Catalysts," *Reactive Polym.*, **9**, 81 (1988).
- Hwu, D. H., C. Hwang, Y. P. Shih, M. Y. Yeh, and C. L. Chao, "Kinetics of the Synthesis of Benzyl Ethers Using Tertiary Amines as Catalysts," *Ind. Eng. Chem. Res.*, **31**, 177 (1992).
- Ido, T., K. Yamaguchi, H. Itoh, and S. Goto, "Catalytic Activity of Phase Transfer Catalyst in a Third Phase," *Kagaku Kogaku Ronbunshu*, **21**, 715 (1995a).
- Ido, T., K. Yamaguchi, T. Yamamoto, and S. Goto, "Effective Use of Phase Transfer Catalyst in a Third Phase," *Kagaku Kogaku Ronbunshu*, **21**, 804 (1995b).
- Idoux, J. P., and J. T. Gupton, "Multisite Phase Transfer Catalysts," *Phase-Transfer Catalysis: New Chemistry, Catalysts, and Applications*, C. M. Starks, ed., Amer. Chem. Soc. Symp. Ser. No. 326, p. 38 (1987).
- Iizawa, T., S. Akatsuka, and T. Nishikubo, "Solid-Liquid-Solid Triphase Transfer Reaction of Poly(chloromethylstyrene)," *Poly. J.*, **19**, 1413 (1987).
- Jagdale, S. J., S. V. Patil, and M. M. Salunke, "Synthesis of Phenacyl Esters by Using PTC and Dibenzo-18-Crown-6," *Synth. Commun.*, **26**, 1747 (1996).
- Jarrouse, M. J., "The Influence of Quaternary Ammonium Chloride on the Reaction of Labile Hydrogen Compounds and Chlorine-Substituted Chlorine Derivatives," *C. R. Acad. Sci. Ser.*, **232**, 1424 (1951).
- Jeffrey, T., "A Short, Highly Stereoselective Palladium and Phase Transfer Catalyzed Synthesis of Pellitorine," *Synth. Commun.*, **18**, 77 (1988).
- Joulet, B., L. Blanco, and G. Rousseau, "New Method for the Reaction of Nitroalkanes with Unsaturated Esters," *Synlett.*, 907 (1991).
- Kachurin, O. I., A. P. Zarakii, L. I. Velichko, N. A. Zarakskaya, N. M. Matvienko, and Z. A. Okhrimenko, "Phase Transfer Catalysis in Reactions of Electrophilic Aromatic Substitution," *Russ. Chem. Bull.*, **44**, 1815 (1995).
- Kelly, J., and D. C. Sherrington, "Some Novel Polymer-Supported Optically Active Phase Transfer Catalysts: 2. Use in Displacement, Reduction, Epoxidation and Addition Reactions," *Polymer*, **25**, 1499 (1984).
- Kimura, Y., and S. L. Regen, "Poly(Ethylene Glycols) and Poly(Ethylene Glycol)-Grafted Copolymers are Extraordinary Catalysts for Dehydrohalogenation Under Two-Phase and Three-Phase Conditions," *J. Org. Chem.*, **48**, 195 (1983a).
- Kimura, Y., and S. L. Regen, "High Dilution via Solid-Liquid Phase Transfer Catalysis: A Practical Approach to the Synthesis of Macrolides," *J. Org. Chem.*, **48**, 1533 (1983b).
- Kise, H., K. Araki, and M. Seno, "Phase Transfer Catalysis of Modified Dextran Anion Exchangers," *Tetr. Lett.*, **22**, 1017 (1981).
- Koch, M., and A. Magni (Gruppo Lepetit), "Serene Derivatives," U.S. Patent 4,501,919 (Chem. Abstr. 102:204296k) (1985).
- Kondo, S., K. Ohta, Y. Inagaki, M. Minafuji, H. Yasui, V. Nakashima, M. Iwasaki, K. Furukawa, and K. Tsuda, "Polymeric Analogs of Dipolar Aprotic Solvents as Phase Transfer Catalysts," *Pure Appl. Chem.*, **60**, 387 (1988).
- Kondo, S., H. Yasui, and K. Tsuda, "Insoluble Polymeric Sulfoxides as Liquid-Solid-Liquid and Solid-Solid-Liquid Triphase Catalysts," *Makromol. Chem.*, **190**, 2079 (1989).
- Kondo, S., M. Takesue, M. Suzuki, H. Kunisada, and Y. Yuki, "Polystyrene-supported Dimethylformamides as Phase Transfer Cata-

- lysts in Solid-Solid-Liquid System," *J. M. S.-fire Appl. Chem.*, **A31**, 2033 (1994).
- Landini, D., F. Montanari, and F. Rolla, "Reaction of Alkyl Halides and Methanesulfonates with Aqueous Potassium Fluoride in the Presence of Phase Transfer Catalysts: A Facile Synthesis of Primary and Secondary Alkyl Fluorides," *Synthesis*, **428** (1974).
- Landini, D., A. Maia, and F. Montanari, "Mechanism of Phase Transfer Catalysis," *J. Chem. Soc., Chem. Comm.*, **112** (1977).
- Landini, D., A. Maia, and F. Montanari, "Study of Reactivity of Anions as a Function of Structure of Catalyst, Solvent, and Hydration Shell," *J. Amer. Chem. Soc.*, **100**, 2796 (1978).
- Landini, D., A. Maia, and F. Montanari, "Dehydrating Effect of Concentrated Aqueous Alkaline Solutions in Aliphatic Nucleophilic Substitutions Carried Out in Aqueous-Organic Two-Phase Systems: The Different Behavior of Various Phase Transfer Catalysts: Quaternary Salts, Crown Ethers and Cryptands," *Isr. J. Chem.*, **26**, 263 (1985).
- Landini, D., A. Maia, and A. Rampoldi, "Stability of Quaternary Onium Salts Under Phase-Transfer Conditions in the Presence of Aqueous Alkaline Solutions," *J. Org. Chem.*, **51**, 3187 (1986).
- Lavelle, P., "Phase Transfer Catalysts," *Spec. Chem.*, **6**, 16, 18, 20 (C.A. 105:208179) (1986).
- Lele, S. S., R. R. Bhawe, and M. M. Sharma, "Fast and Very Slow Reactions: Phase Transfer Catalysis," *Chem. Eng. Sci.*, **38**, 765 (1983).
- Leung, L. M. W. H. Chan, S. K. Leung, and S. M. Fung, "Synthesis of Aliphatic and Aromatic Poly(s-dithiocarbonates) Using a Phase Transfer Catalyst," *J. M. S.-Pure Appl. Chem.*, **A31**, 495 (1994).
- Lin, C. L., and T. J. Pinnavaia, "Organo-Clay Assemblies for Triphase Catalysis," *Chem. Mater.*, **3**, 213 (1991).
- Lindblom, L., and M. Elander, "Phase Transfer Catalysis in the Production of Pharmaceuticals," *Pharmaceutical Tech.*, **4**, 59 (1980).
- Lindley, J., and T. J. Mason, "Sonochemistry: 2. Synthetic Applications," *Chem. Soc. Rev.*, **16**, 275 (1987).
- Liotta, C. L., E. M. Burgess, C. C. Ray, E. D. Black, and B. E. Fair, "Mechanism of Phase Transfer Catalysis: The Omega Phase," *Amer. Chem. Soc. Symp. Ser. No. 326*, 15 (1987).
- Loupy, A., A. Petit, M. Ramdani, C. Yvanaeff, M. Majdoub, B. Labiad, and D. Villemin, "The Synthesis of Esters under Microwave Irradiation Using Dry-Media Conditions," *Can. J. Chem.*, **71**, 90 (1993).
- Luche, J. L., C. Einhorn, J. Einhorn, J. C. De Souza Barboza, C. Petrier, C. Depuy, P. Delair, C. Allavena, and T. Tuschl, "Ultrasonic Waves as Promoters of Radical Processes in Chemistry: The Case of Organometallic Reactions," *Ultrasonics*, **28**, 316 (1990).
- MacKenzie, W. M., and D. C. Sherrington, "Mechanism of Solid-Liquid Phase Transfer Catalysis," *Polymer*, **21**, 792 (1980).
- MacKenzie, W. M., and D. C. Sherrington, "Substrate Selectivity Effects Involving Polymer-Supported Phase Transfer Catalysts," *Polymer*, **22**, 431 (1981).
- Maidan, R., and I. Willner, "Photochemical and Chemical Enzyme Catalyzed Debromination of mes-1,2-dibromostilbene in Multiphase Systems," *J. Amer. Chem. Soc.*, **108**, 1080 (1986).
- Makosza, M., "Two-Phase Reactions in the Chemistry of Carbanions and Halocarbenes: A Useful Tool in Organic Synthesis," *Pure Appl. Chem.*, **43**, 439 (1975).
- Makosza, M., "Reactions of Carbanions and Halogenocarbenes in Two-Phase Systems," *Russ. Chem. Rev.*, **46**, 1151 (1977).
- Makosza, M., and E. Bialecka, "Reactions of Organic Ions: LXXIII. Alkylation of Phenylacetonitrile at the Interface with Aqueous Sodium Hydroxide," *Tetr. Lett.*, **2**, 983 (1977).
- Marconi, P. F., and W. T. Ford, "Catalytic Effectiveness Due to Mass Transfer Limitations in Triphase Catalysis by Polymer-Supported Quaternary Onium Salts," *J. Catal.*, **83**, 160 (1983).
- Mason, D., S. Magdassi, and Y. Sasson, "Role of a Third Liquid Phase-Transfer Catalysis," *J. Org. Chem.*, **56**, 7229 (1991).
- Mason, T. J., J. P. Lorimer, L. Paniwynk, A. R. Harris, P. W. Wright, G. Bram, A. Loupy, G. Ferradou, and J. Sansoulet, "The O-Alkylation of 5-Hydroxy Chromones: A Comparison of Two Nonclassical Techniques, PTC in the Absence of Solvent and Sonochemical Activation in Polar Aprotic Solvents," *Synth. Commun.*, **20**, 3411 (1990).
- Mason, T. J., "Industrial Sonochemistry: Potential and Practicality," *Ultrasonics*, **30**, 192 (1992).
- Masse, J., "Phase-Transfer Catalysis in the N-Alkylation of 2-Chlorophenothiazine," *Synthesis*, **341** (1977).
- Mathias, L. J., and R. A. Vaidya, "Inverse Phase Transfer Catalysis. First Report of a New Class of Interfacial Reactions," *J. Amer. Chem. Soc.*, **108**, 1093 (1986).
- Maurin, L., "Dehydrohalogenation," (DuPont de Nemours) U.S. Patent 4,418,232 (C.A. 100:52179t) (1983).
- McKenzie, W. M., and D. C. Sherrington, "Substrate Selectivity Effects Involving Polymer-Supported Phase Transfer Catalysts," *Polymer*, **22**, 431 (1981).
- Mehra, A., *Handbook of Heat and Mass Transfer*, Vol. 4, N. Chermisnoff, ed., Gulf Publishing, Houston, p. 735 (1990).
- Melville, J. B., and J. D. Goddard, "Mass-Transfer Enhancement and Reaction-Rate Limitations in Solid-Liquid Phase-Transfer Catalysis," *Chem. Eng. Sci.*, **40**, 2207 (1985).
- Melville, J. B., and J. D. Goddard, "A Solid-Liquid Phase Transfer Catalysis in Rotating-Disk Flow," *Ind. Engng. Chem. Res.*, **27**, 551 (1988).
- Melville, J. B., and J. D. Goddard, *Handbook of Heat and Mass Transfer: 4. Advances in Reactor Design and Combustion Science*, N. Chermisnoff, ed., Gulf Publishing, Houston, p. 345 (1990).
- Melville, J. B., and Y. C. Yortos, "Phase Transfer Catalysis with Rapid Reaction," *Chem. Eng. Sci.*, **41**, 2873 (1986).
- Mills, P. L., P. A. Ramachandran, and R. V. Chaudhari, "Multiphase Reaction Engineering for Fine Chemicals and Pharmaceuticals," *Revs. Chem. Eng.*, **8**, 1 (1992).
- Molinari, H., F. Montanari, S. Quici, and P. Tundo, "Polymer-Supported Phase-Transfer Catalysis. High Catalytic Activity of Ammonium and Phosphonium Salts Bonded to a Polystyrene Matrix," *J. Amer. Chem. Soc.*, **101**, 3920 (1979).
- Montanari, F., S. Quici, and P. Tundo, "Mechanism of Reactions Promoted by Polymer-Supported Phase-Transfer Catalysts," *J. Org. Chem.*, **48**, 199 (1983).
- Naik, S. D., and L. K. Doraiswamy, "Mathematical Modeling of Solid-Liquid Phase Transfer Catalysis," *Chem. Eng. Sci.*, **52**, 4533 (1997).
- Neef, G., and A. Steinmeyer, "Synthesis of 2,3-oxa-Calcitriol Derivatives," *Tetr. Lett.*, 5073 (1991).
- Neumann, R., and Y. Sasson, "Mechanism of Base-Catalyzed Reactions in Phase-Transfer Systems with Poly(ethylene glycol) as Catalysts: The Isomerization of Allylanisole," *J. Org. Chem.*, **49**, 3448 (1984).
- Neumann, R., and Y. Sasson, "An Evaluation of Polyethylene Glycol as a Catalyst in Liquid-Gas Phase Transfer Catalysis: The Base Catalyzed Isomerization of Allylbenzene," *J. Mol. Catal.*, **33**, 201 (1985a).
- Neumann, R., and Y. Sasson, "The Autooxidation of Alkyl Nitroaromatic Compounds in Base-Catalyzed Phase Transfer Catalysis by Polyethylene Glycol under Ultrasonic Condition," *J. Chem. Soc., Chem. Commun.*, 616 (1985b).
- Nishikubo, T., T. Iizawa, S. Akatsuka, and M. Okawara, "Substitution Reaction of Poly(chloromethylstyrene) with Some Nucleophilic Reagents Using Triphase Transfer Catalysis," *Poly. J.*, **15**, 911 (1983).
- Norwicki, J., and J. Gora, "Synthesis of New Fragrances from Furfural: II. Synthesis of New 2-alkyl-2-alkenyl-3-(2-furyl)propanol Derivatives," *Pol. J. Chem.*, **65**, 2267 (1991).
- O'Donnell, M. J., "Asymmetric Phase Transfer Reactions," *Catalytic Asymmetric Synthesis*, I. Ojima, ed., VCH Publishers, New York, p. 389 (1993).
- O'Donnell, M. J., W. D. Bennett, and S. Wu, "The Stereoselective Synthesis of α -Amino Acids by Phase-Transfer Catalysis," *J. Amer. Chem. Soc.*, **111**, 2353 (1989).
- Ohtani, N., C. A. Wilkie, A. Nigam, and S. L. Regen, "Triphase Catalysis: Influence of Percent Ring Substitution on Active-Site Mobility, Macroenvironment, Microenvironment, and Efficiency," *Macromolecules*, **14**, 516 (1981).
- Okahata, Y., and K. Ariga, "A New Type of Phase-Transfer Catalysts (PTC): Reaction of Substrates in the Inner Organic Phase with the Outer Aqueous Anions Catalyzed by PTC Grafted on the Capsule Membrane," *J. Org. Chem.*, **51**, 5064 (1986).
- Pielichowski, J., and P. Czub, "A Modified Synthesis of 9-(1,2-Dichlorovinyl)Carbazole by Using Crown Ethers and Cryptands in a Non-Aqueous System," *Synth. Commun.*, **25**, 3647 (1995).
- Pletcher, D., and E. M. Valdes, "Studies of the Ce(III)/Ce(IV) Cou-

- ple in Multiphase Systems Containing a Phase Transfer Reagent: I. Conditions for the Extraction of Ce(IV) and Electrode Kinetics," *Electrochimica Acta*, **33**, 499 (1988a).
- Pletcher, D., and E. M. Valdes, "Studies of the Ce(III)/Ce(IV) Couple in Multiphase Systems Containing a Phase Transfer Reagent: II. Indirect Oxidations and the Electrolytic Preparation of Ceric Nitrate," *Electrochimica Acta*, **33**, 509 (1988b).
- Pradhan, N. C., and M. M. Sharma, "Kinetics of Reactions of Benzyl Chloride/-Chlorobenzyl Chloride with Sodium Sulfide: Phase-Transfer Catalysis and the Role of the Omega Phase," *Ind. Eng. Chem. Res.*, **29**, 1103 (1990).
- Pradham, N. C., and M. M. Sharma, "Solid-Liquid Reactions Catalyzed by Alumina and Ion Exchange Resin: Reactions of Benzyl Chloride/p-Chlorobenzyl Chloride with Solid Sodium Sulfide," *Ind. Eng. Chem. Res.*, **31**, 1610 (1992).
- Quici, S., and S. L. Regen, "Alumina as a Triphase Catalyst," *J. Org. Chem.*, **44**, 3436 (1979).
- Rabinovitz, M., Y. Cohen, and M. Halpern, "Hydroxide Ion Initiated Reactions Under Phase Transfer Catalysis Conditions: Mechanism and Implications," *Angew. Chem., Int. Ed. Engl.*, **25**, 960 (1986).
- Ragaini, V., G. Verzella, A. Ghigone, and G. Colombo, "Fixed-Bed Reactors for Phase-Transfer Catalysis: A Study of a Liquid-Liquid-Solid Reaction," *Ind. Eng. Chem. Process Des.Dev.*, **25**, 878 (1986).
- Ragaini, V., G. Colombo, and P. Barzhagi, "Phenylacetonitrile Alkylation with Different Phase-Transfer Catalysts in Continuous Flow and Batch Reactors," *Ind. Eng. Chem. Res.*, **27**, 1382 (1988).
- Ragaini, V., G. Colombo, P. Barzhagi, E. Chiellini, and S. D'Antone, "Phase Transfer Alkylation of Phenylacetonitrile in Prototype Reactors Under Magnetic or Ultrasound Mixing Conditions: 2. Kinetic Modeling," *Ind. Eng. Chem. Res.*, **29**, 924 (1990).
- Raner, K. D., C. R. Strauss, and R. W. Trainor, "A New Microwave Reactor for Batchwise Organic Synthesis," *J. Org. Chem.*, **60**, 2456 (1995).
- Ratoarinoro, N., A. M. Wilhelm, J. Berlan, and H. Delmas, "Effects of Ultrasound Emitter Type and Power on a Heterogeneous Reaction," *Chem. Eng. J.*, **50**, 27 (1992).
- Reetz, M. T., and R. Ostarek, "Polymerization of Acrylic Acid Esters Initiated by Tetrabutylammonium Alkyl and Aryl Thiolates," *J. Chem. Soc., Chem. Comm.*, 213 (1988).
- Regen, S., "Triphase Catalysis," *J. Am. Chem. Soc.*, **97**, 5956 (1975).
- Regen, S., and A. Singh, "Biphasic Sonochemistry: Convenient Generation of Dichlorocarbene," *J. Org. Chem.*, **47**, 1587 (1982).
- Reuben, B., and K. Sjöberg, "Phase Transfer Catalysis in Industry," *Chemtech*, 315 (1981).
- Ruckenstein, E., and L. Hong, "Hydrophilic Recognition by Polymer-supported Phase Transfer Catalysts and Its Effect on Reaction Activity and Selectivity," *J. Catal.*, **136**, 378 (1992).
- Ruckenstein, E., and J. S. Park, "Hydrophilic-Hydrophobic Polymer Composites," *J. Poly. Sci., Part C: Polym. Lett.*, **26**, 529 (1988).
- Sarkar, A., B. R. Rao, and M. M. Konar, "Montmorillonite Supported Borohydride: A New Reducing Agent for Reductions Under Phase Transfer Conditions," *Synth. Comm.*, **19**, 2313 (1989).
- Sasson, Y., and H. A. Zahalka, "Catalyst Poisoning Phenomenon in Phase Transfer Catalysis Effect of Aqueous Phase Concentration," *J. Chem. Soc., Chem. Commun.*, 1347 (1983).
- Savelova, V. A., and L. N. Vakhiova, "Synergism and Antagonism in Phase Transfer Catalysis," *Russ. Chem. Bull.*, **44**, 2012 (1995).
- Sawicki, R. A., "Phase Transfer Catalysts Polyethylene Glycols Immobilized Onto Metal Oxide Surfaces," *Tetr. Lett.*, **23**, 2249 (1982).
- Schlunt, P., and P. C. Chau, "The Reaction of a Polymer-Bound Phase Transfer Catalyst in a Novel Cyclic Slurry Reactor," *J. Catal.*, **102**, 348 (1986).
- Schmolka, S. J., and H. Zimmer, "N-dimethylaminopropylation in a Solid-Liquid Two Phase System: Synthesis of Chlorpromazine, Its Analogs, and Related Compounds," *Synthesis*, 29 (1984).
- Shaffer, T. D., and M. C. Kramer, "Bimechanistic Phase Transfer Catalyzed Polythioetherification," *Makromol. Chem.*, **191**, 3157 (1990).
- Shan, Y., R. H. Kang, and W. Li, "Investigation of Phase-Transfer Reactions Catalyzed by Poly(ethylene glycol) Bound to Macroporous Polystyrene Supports," *Ind. Eng. Chem. Res.*, **28**, 1289 (1989).
- Sharma, M. M., Personal Communication (1997).
- Shenoy, G., and D. Rangnekar, "Synthesis of Desylesters by the Application of Phase Transfer Catalysis and a Study of the Fluorescent Properties of 2-Substituted 4,5-Diphenyloxazoles Derived from Desyl Esters," *Dyes and Pigments*, **10**, 165 (1989).
- Shimada, S., K. Nakagawa, and K. Tabuchi, "Photopolymerization of Methyl Methacrylate with 1-benzyl-1,4-Dihydropyridinamide in the Presence of Carbon Tetrachloride," *Poly. J.*, **21**, 275 (1989).
- Shimada, S., Y. Obata, K. Nakagawa, and K. Tabuchi, "Photopolymerization of Methyl Methacrylate with Methyl-Viologen-Sodium Dithionite-Carbon Tetrachloride in Aqueous-Organic Two Phase System," *Poly. J.*, **22**, 777 (1990).
- Shimizu, S., Y. Sasaki, and C. Hirai, "Inverse Phase Transfer Catalysis. Palladium-Catalyzed Reduction of Bromoanisoles with Sodium Formate," *Bull. Chem. Soc. Jpn.*, **63**, 176 (1990).
- Smith, L. R., "Preparation of Furfylethanalamines as Intermediates for Herbicide Antidotes," Monsanto Co., U.S. Patent 4,962,212 (Chem. Abstr. 114:143116a) (1990).
- Solaro, R., S. D'Antone, and E. Chiellini, "Heterogeneous Ethylation of Phenylacetonitrile," *J. Org. Chem.*, **45**, 4179 (1980).
- Sprecker, M. A., and M. R. Hanna, "1-Phenyl-4-penten-1-one and Methyl Homologs Thereof and Their Use in Perfume Composition," International Flavors and Fragrances Inc., Brit. U.K. Pat. Appl. GBB2139222, U.S. Appl. 487045 (Chem. Abstr. 102:P220567e) (1982).
- Stanley, T. J., and J. A. Quinn, "Phase Transfer Catalysis in a Membrane Reactor," *Chem. Eng. Sci.*, **42**, 2313 (1987).
- Starks, C. M., "Phase-Transfer Catalysis: I. Heterogeneous Reactions Involving Anion Transfer by Quaternary Ammonium and Phosphonium Salts," *J. Amer. Chem. Soc.*, **93**, 195 (1971).
- Starks, C. M., "Quaternary Ammonium Salts as Phase Transfer Catalysts," in *Industrial Applications of Surfactants II*, Karsa, ed., Roy. Soc. of Chemistry, Cambridge, p. 165 (1990).
- Starks, C. M., and C. Liotta, *Phase Transfer Catalysis: Principles and Techniques*, Academic Press, New York (1978).
- Starks, C. M., and R. M. Owens, "Phase Transfer Catalysis: II. Kinetic Details of Cyanide Displacement on 1-Haloocanes," *J. Amer. Chem. Soc.*, **95**, 3613 (1973).
- Starks, C. M., C. L. Liotta, and M. Halpem, *Phase-Transfer Catalysis: Fundamentals, Applications, and Industrial Perspectives*, Chapman and Hall, New York (1994).
- Svec, F., "What is the Real Mechanism of Polymer-Supported Phase-Transfer Catalysis?," *Pure Appl. Chem.*, **60**, 377 (1988).
- Szabo, T., K. Aranyosi, M. Csiba, and L. Toke, "Co-Catalytic Effects in Phase-Transfer Catalyzed Reactions," *Synthesis*, 565 (1987).
- Tagle, L. H., F. R. Diaz, and R. Fuenzalida, "Polymerization by Phase Transfer Catalysis. 18. Polycarbonates and Polythiocarbonates from Chlorinated Diphenols," *J. M. S.-Pure Appl. Chem.*, **A31**, 283 (1994).
- Telford, S., P. Schlunt, and P. C. Chau, "Mechanisms of Polymer-Supported Phase Transfer Catalysis. Effect of Phase Ratios on Low Percent Ring Substitution Microporous Polystyrene Resin," *Macromol.*, **19**, 2435 (1986).
- Tomioka, H., K. Ueda, H. Ohi, and Y. Izawa, "Photochemical and Chemical Reduction of Nitroalkenes Using Viologens as an Electron Phase Transfer Catalyst," *Chem. Lett.*, 1359 (1986).
- Tomoi, M., and W. T. Ford, "Mechanisms of Polymer-Supported Catalysis: I. Reaction of 1-Bromooctane with Aqueous Sodium Cyanide Catalyzed by Polystyrene-Bound Benzyltri-n-butylphosphonium Ion," *J. Amer. Chem. Soc.*, **103**, 3821 (1981).
- Totten, G. E., and N. A. Clinton, "Poly(ethylene glycol) Derivatives as Phase Transfer Catalysts and Solvents for Organic Reactions," *J. Macromol. Sci. Rev., Makromol. Chem.*, **C28**, 293 (1988).
- Trotta, F., "Phthalic Acid Esters Hydrolysis Under Inverse Phase-Transfer Catalysis Conditions," *J. Mol. Cat.*, **85**, L265 (1993).
- Trotta, F., P. Tundo, and G. Moraglio, "Selective Mono-N-Alkylation of Aromatic Amines by Dialkyl Carbonate Under Gas-Liquid Phase-Transfer Catalysis (GL-PTC) Conditions," *J. Org. Chem.*, **52**, 1300 (1987).
- Trifonov, A. Z., and T. T. Nikiforov, "Cyclodextrins as Phase Transfer Catalysts in a Nucleophilic Displacement Reaction," *J. Mol. Catal.*, **24**, 15 (1984).
- Tsanov, T., K. Vassiler, R. Stamenova, and C. Tsvetov, "Cross-linked Poly(ethylene oxide) Modified with Tetraalkyl Ammonium Salts as Phase Transfer Catalyst," *J. Poly. Sci., Part A: Poly. Chem.*, **33**, 2623 (1995).
- Tundo, P., "Silica Gel as Polymeric Support for Phase-Transfer Catalysts," *J. Chem. Soc., Chem. Commun.*, 644 (1977).

- Tundo, P., and M. Badiali, "High Activity in Displacement Reactions Catalyzed by Quaternary Onium Salts Immobilized on Inorganic Matrices," *Reactive Poly.*, **10**, 55 (1989).
- Tundo, P., and M. Selva, "Simplify Gas-Liquid Phase Transfer Catalysis," *Chemtech*, **25**(5), 31 (1995).
- Tundo, P., and P. Venturello, "Synthesis, Catalytic Activity and Behaviour of Phase-Transfer Catalysts Supported on Silica Gel. Strong Influence of Substrate Adsorption on the Polar Polymeric Matrix on the Efficiency of the Immobilized Phosphonium Salts," *J. Amer. Chem. Soc.*, **101**, 6606 (1979).
- Tundo, P., and P. Venturello, "Catalysis Mechanism of Phosphonium Salts Supported on Silica Gel in Organic-Aqueous Two-Phase Systems," *J. Amer. Chem. Soc.*, **103**, 856 (1981).
- Tundo, P., G. Moraglio, and F. Trotta, "Gas-Liquid Phase Transfer Catalysis: A New Continuous Flow Method in Organic Synthesis," *Ind. Eng. Chem. Res.*, **28**, 881 (1989).
- Tundo, P., F. Trotta, and G. Moraglio, "Continuous-Flow Processes Under Gas-Liquid Phase-Transfer Catalysis (GL-PTC) Conditions: The Reaction of Dialkyl Carbonates with Phenols, Alcohols, and Mercaptans," *Ind. Eng. Chem. Res.*, **27**, 1565 (1988).
- Tundo, P., P. Venturello, and E. Angeletti, "Phase Transfer Catalysts Immobilized and Adsorbed on Alumina and Silica Gel," *J. Amer. Chem. Soc.*, **104**, 6551 (1982).
- Tundo, P., P. Venturello, and E. Angeletti, "Quaternary Onium Salts Immobilized on Inorganic Matrices," **26**, 283 (1985).
- Velichko, L. I., A. P. Zaraiski, O. I. Kachurin, N. M. Matienko, Z. A. Okhrimenko, and N. A. Zaraiskaya, "Phase Transfer Catalysis in Electrophilic Substitution Reactions: 1. Synthesis and Physico-Chemical Properties of Potential Catalysts of the Electrophile Interphase Transfer," *Ukrainian Chem. J.*, **94** (1992).
- Villemin, D., and B. Labadi, "Dihalocyclopropanation of Phenylthio of Butylthio Cycloalkenes under Phase Transfer Conditions: Opening of Cyclopropanes Under Microwave Irradiation," *Synth. Commun.*, **22**, 2043 (1992).
- Wamser, C. C., and J. A. Yates, "Kinetics and Mechanisms for the Two-Phase Reaction Between Aqueous Aniline and Benzoyl Chloride in Chloroform, with and without Pyridine Catalysis," *J. Org. Chem.*, **54**, 150 (1989).
- Wang, D. H., and H. S. Weng, "Preliminary Study on the Role Played by the Third Liquid Phase in Phase Transfer Catalysis," *Chem. Eng. Sci.*, **43**, 209 (1988).
- Wang, D. H., and H. S. Weng, "Solvent and Salt Effects on the Formation of the Third Liquid Phase and the Reaction Mechanisms in the Phase Transfer Catalysis System-Reaction Between n-butyl Bromide and Sodium Phenolate," *Chem. Eng. Sci.*, **50**, 3477 (1995).
- Wang, J. X., and K. Zhao, "Synthesis of Cis and Trans-2,6-Diphenyl-1,4-Dielselanium Fulvenes from Phenylacetylene with Selenium and Base under PTC-Ultrasound Conditions," *Synth. Commun.*, **26**, 1617 (1996).
- Wang, M. L., and S. W. Chang, "Kinetics of the Allylation of Phenoxide by Polyethylene Glycol in a Two Phase Reaction," *Can. J. Chem. Eng.*, **69**, 340 (1991a).
- Wang, M. L., and S. W. Chang, "Reaction Mechanism and Kinetics of the Allylation of Phenoxide in the n-Decane/H₂O-PEG-400 System," *Ind. Eng. Chem. Res.*, **30**, 2378 (1991b).
- Wang, M. L., and S. W. Chang, "Model of the Kinetics of Synthesizing Formaldehyde Acetals by Phase Transfer Catalysis," *Ind. Eng. Chem. Res.*, **33**, 1606 (1994).
- Wang, M. L., and S. W. Chang, "Synthesis of Unsymmetric Acetal Compounds Under Phase Transfer Catalysis and Separation of the Products," *Ind. Eng. Chem. Res.*, **34**, 3696 (1995).
- Wang, M. L., and H. S. Wu, "Effects of Mass Transfer and Extraction of Quaternary Salts on a Substitution Reaction by Phase Transfer Catalysis," *J. Org. Chem.*, **55**, 2344 (1990).
- Wang, M. L., and H. S. Wu, "Kinetic and Mass Transfer Studies of a Sequential Reaction by Phase Transfer Catalysis," *Chem. Eng. Sci.*, **46**, 509 (1991).
- Wang, M. L., and H. M. Yang, "Kinetic Study of Synthesizing 2,4,6-Tribromophenol Allyl Ether by Phase Transfer Catalytic Reaction," *Ind. Eng. Chem. Res.*, **29**, 522 (1990).
- Wang, M. L., and H. M. Yang, "Dynamics of Phase Transfer Catalyzed Reaction for the Allylation of 2,4,6-Tribromophenol," *Chem. Eng. Sci.*, **46**, 619 (1991a).
- Wang, M. L., and H. M. Yang, "A Pseudo-Steady-State Approach for Triphase Catalysis in a Batch Reactor," *Ind. Eng. Chem. Res.*, **30**, 2384 (1991b).
- Wang, M. L., and H. M. Yang, "Dynamic Model of the Triphase Catalytic Reaction," *Ind. Eng. Chem. Res.*, **31**, 1868 (1992).
- Wang, M. L., C. C. Ou, and J. J. Jwo, "Effect of Organic Solvents on the Pyridine-l-Oxide Catalyzed Reaction of Benzoyl Chloride with Acetate Ion in a Two Phase Medium," *Ind. Eng. Chem. Res.*, **33**, 2034 (1994).
- Wang, Y., and Y. Jiang, "Rapid Alkylation of Ethylphenylsulfonyle Acetate Under Microwave Irradiation," *Synth. Commun.*, **22**, 2287 (1992).
- Wang, Y., R. Deng, M. Aiqiao, and Y. Jiang, "Solid-Liquid Phase Transfer Catalytic Synthesis: XII: Microwave Irradiated Alkylation of Diethyl Malonate," *Synth. Commun.*, **25**, 1761 (1995).
- Watanabe, Y., and T. Mukiyama, "A Convenient Method for the Synthesis of Carboxamides and Peptides by the Use of Tetrabutyl Ammonium Salts," *Chem. Lett.*, **285** (1981a).
- Watanabe, Y., and T. Mukiyama, "A Novel Method for the Synthesis of β -Lactams by Means of Phase Transfer System," *Chem. Lett.*, **443** (1981b).
- Wong, K. H., and A. P. W. Wai, "Solid-Liquid Phase Transfer Kinetics of p-Nitrobenzoate Esterification Catalyzed by Crown Ethers: A Comparison of the Catalytic Efficiency of Various Crown Ethers," *J. Chem. Soc. Perkin Trans.*, **2**, 317 (1983).
- Wrobel, J. T., and E. Hejchman, "Spiro Derivatives of Tetrahydrothiophene. Synthesis of the Quinolizidine (3-Spiro-2') Tetrahydrothiophene System Using Solid/Liquid or Liquid/Liquid Phase-Transfer Catalysis," *Synthesis*, **452** (1987).
- Wu, H. S., "Phase Plane Modeling of a Liquid-Liquid Phase-Transfer-catalyzed Reaction," *Ind. Eng. Chem. Res.*, **32**, 1323 (1993).
- Wu, H. S., "Mathematical Modeling of Liquid-Liquid Phase Transfer Catalysis," *Chem. Eng. Sci.*, **51**, 827 (1996).
- Yadav, G. D., and M. M. Sharma, "Kinetics of Reaction of Benzyl Chloride with Sodium Acetate/Benzoate: Phase Transfer Catalysis in Solid-Liquid System," *Ind. Eng. Chem. Proc. Des. Dev.*, **20**, 385 (1981).
- Yadav, G. D., and C. K. Mistry, "A New Model of Capsule Membrane Phase Transfer Catalysis for Oxidation of Benzyl Chloride to Benzaldehyde with Hydrogen Peroxide," *J. Mol. Catal.*, **102**, 67 (1995).
- Yadav, G. D., and P. H. Mehta, "Theoretical and Experimental Analysis of Capsule Membrane Phase Transfer Catalysis: Selective Alkaline Hydrolysis of Benzyl Chloride to Benzyl Alcohol," *Catal. Lett.*, **21**, 391 (1993).
- Yanagida, S., K. Takahashi, and M. Okahara, "Solid-Solid-Liquid Three Phase Transfer Catalysis of Polymer Bound Acyclic Poly(oxyethylene) Derivatives: Applications to Organic Synthesis," *J. Org. Chem.*, **44**, 1099 (1979).
- Yeh, M. Y., H. H. Guo, L. C. Chen, and Y. P. Shin, "Kinetics of Phase-Transfer Catalytic Esterification of Phthalic Acid Monobutyl Ester," *Ind. Eng. Chem. Res.*, **27**, 1582 (1988).
- Yufit, S. S., "Some Problems in PTC Theory: Solvation, Crystalline Lattice Strength, and Topology," *Russ. Chem. Bull.*, **44**, 1989 (1995).
- Yuan, Y., D. Gao, and Y. Jiang, "Ethoxylation of o,p-Nitrochlorobenzene Using Phase Transfer Catalysts by Microwave Irradiation," *Synth. Commun.*, **22**, 2117 (1992a).
- Yuan, Y., Y. Jiang, and D. Gao, "Microwave Irradiation Promoted Reactions of Carboxylic Acids with Halides in the Presence of Quaternary Ammonium Salt," *Synth. Commun.*, **22**, 3109 (1992b).
- Zahalka, H. A., and Y. Sasson, "Esterification of 1,4-Dichlorobutane with Sodium Formate Under Solid-Liquid Phase Transfer Catalysis. A Kinetic Study," *Can. J. Chem.*, **67**, 245 (1989).
- Zaidman, B., Y. Sasson, and R. Neumann, "General Economic Evaluation of the Use of Quaternary Ammonium Salts as Catalysts in Industrial Applications," *Ind. Eng. Chem. Prod. Des. Dev.*, **24**, 390 (1985).
- Zerda, J., R. Neumann, and Y. Sasson, "Hofmann Decomposition of Quaternary Ammonium Salts Under Phase-Transfer Catalytic Conditions," *J. Chem. Soc. Perkin Trans.*, **2**, 823 (1986).
- Zubrick, S. W., B. I. Dunbar, and H. D. Durst, "Crown Ether Catalysis: II. Cyanide and Nitrite as "Naked" Anions," *Tetr. Lett.*, **71** (1975).

Manuscript received June 30, 1997, and revision received Dec. 8, 1997.