

the present equivalence can be intended as a way to reduce AI into a line integration.

Finally, we recall that PO is a constitutive part of incremental theories such as the physical theory of diffraction (PTD) [4] and the incremental theory of diffraction [5]. Therefore, the above equivalence allows to complement either AI or PO by the same fringe contributions [6], [7].

REFERENCES

- [1] P. Ya. Ufimtsev, "Elementary edge waves and waveguides," Moscow, 1986, unpublished paper, Notebook 212, Sec. 2, 3, 15, pp. 25, 34, 167–173.
- [2] M. Oodo and M. Ando, "Equivalence of physical optics and the aperture field integration method in the full pattern analysis: Effects of integration surface," in *IEEE AP-S, Int. Symp.*, Newport Beach, CA, June 18–23, 1995, vol. 2, pp. 889–892.
- [3] R. F. Harrington, *Time-Harmonic Electromagnetic Fields*. New York: McGraw-Hill, 1961, ch. 3.
- [4] P. Ya. Ufimtsev, "Elementary edge waves and the physical theory of diffraction," *Electromagn.*, vol. 11, no. 2, pp. 125–159, Apr./June 1991.
- [5] R. Tiberio and S. Maci, "An incremental theory of diffraction: Scalar formulation," *IEEE Trans. Antennas Propagat.*, vol. 42, pp. 600–612, May 1994.
- [6] A. Michaeli, "Incremental diffraction coefficients for the extended physical theory of diffraction," *IEEE Trans. Antennas Propagat.*, vol. 43, no. 7, pp. 732–734, July 1995.
- [7] A. Altintas, O. M. Buyukdura, and P. H. Pathak, "An extension of the PTD concept for aperture radiation problems," *Radio Sci.*, vol. 29, no. 6, pp. 1403–1407, Nov./Dec. 1994.

Photonic Band-Gap Materials for High-Gain Printed Circuit Antennas

Hung-Yu David Yang, Nicolaos G. Alexopoulos,
and Eli Yablonovitch

Abstract—It is found through a vector integral-equation analysis and the reciprocity theorem that the gain of a microstrip antenna can be greatly enhanced with a photonic band-gap (PBG) material layer either as the substrate or the superstrate. The beam angle is found to coincide with that of a leaky-wave mode of a planar-grating structure. This observation suggests that high gain is due to the excitation of strong leaky-wave fields.

Index Terms—Photonic band-gap, printed antennas.

I. INTRODUCTION

In recent years, photonic band-gap (PBG) materials [1] have drawn significant attention in physics and engineering for their analogy to a semiconductor crystal where there exist electron band gaps. A PBG material or photonic crystal is an artificial material made of periodic implants within a surrounding medium. Electromagnetic wave propagation through such a medium is affected by the scattering and diffraction properties of the periodic elements. Planar periodic

Manuscript received August 5, 1996; revised August 20, 1996. This work was supported in part by an NST SBIR subcontract.

H.-Y. D. Yang is with the Department of Electrical Engineering and Computer Science, University of Illinois, Chicago, IL 60607 USA.

N. G. Alexopoulos and E. Yablonovitch are with the Department of Electrical Engineering, University of California, Los Angeles, CA 90032 USA. Publisher Item Identifier S 0018-926X(97)00458-4.

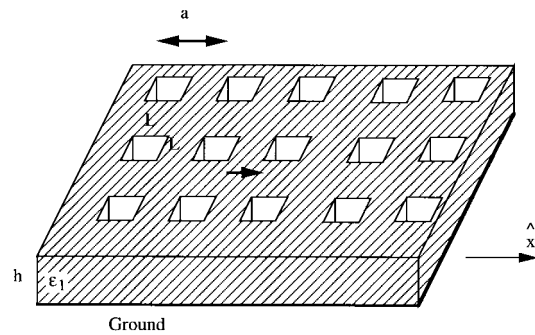

Fig. 1. An elementary printed antenna on a PBG substrate.

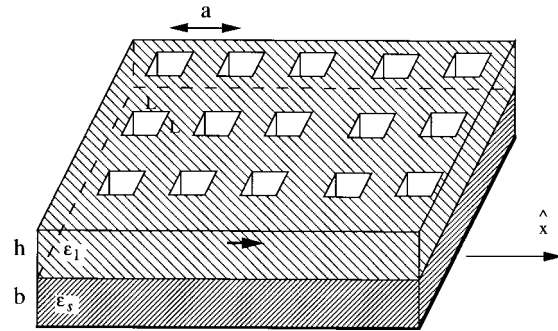

Fig. 2. An elementary printed antenna with a PBG overlay.

printed conducting strips or patches on materials have already had important applications in frequency selective surfaces. Since electromagnetic waves can be highly directional with the PBG materials, it is conceivable that antennas with PBG materials will have many unique characteristics [2], [3]. One of the disadvantages of printed circuit antennas is low gain—typically about 6 dB. It had been demonstrated that the use of multiple periodic layers on top of a microstrip antenna results in significant gain enhancement [4], [5]. This phenomenon was later explained with a leaky-wave theory [6]. The geometry can be treated as a printed antenna structure with a one-dimensional PBG material overlay. This observation leads us to believe that the use of planar PBG materials may enhance printed-antenna gain. Periodic implants placed along the vertical direction of a microstrip structure may result in a device too thick for practical microstrip applications. Planar periodic implants on layered structures are preferred.

The aim of this letter is to demonstrate a gain enhancement method for printed antennas through the use of a PBG material made of planar arrays of rectangular blocks within dielectric layers. A three-dimensional full-wave integral-equation method [7]–[9] in conjunction with a reciprocity theorem is used to determine the far-zone fields due to an elementary current source (a Hertzian dipole) within such structures. Although we consider only the radiation due to an infinitesimal current source, the resulting radiation patterns describe the general features of radiation from printed antennas.

II. ANALYSIS AND RESULTS

General radiation characteristics of printed antennas can be obtained by investigating the far-zone fields from an elementary current source. In this letter, we consider two microstrip structures: a Hertzian dipole on a PBG substrate as in Fig. 1, or on a dielectric substrate with a PBG overlay, as shown in Fig. 2. The PBG material layer

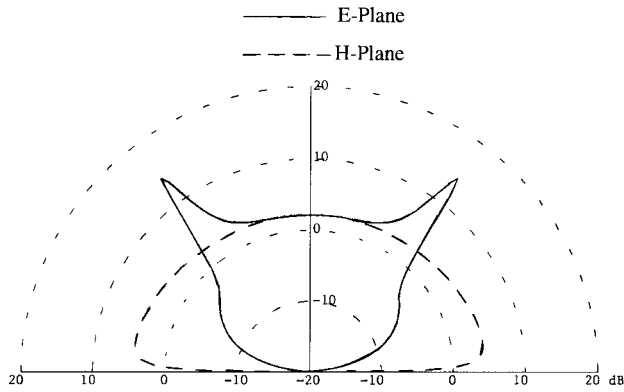

Fig. 3. Directivity pattern of an elementary dipole on a square-lattice PBG substrate. $F = 28$ GHz, $h = 1$ mm, $a = 5$ mm, $L = 3$ mm, $\epsilon_1 = 10$, and the block depth is 1 mm.

considered is made of a dielectric slab with planar square gratings (square air implants). A complete photonic band gap exists when both sides of the layer are coated with conductors, and only a partial band gap exists when conductor is on only one side of the layer. To obtain the far-zone fields for the structures in either Fig. 1 or 2, we may use reciprocity to avoid obtaining the complete field solutions. According to the reciprocity theorem, the far-zone fields of the structures in Fig. 1 or 2 are the same as the fields at the dipole location due to a plane wave incidence. If the dipole is in the \hat{x} direction, then E_θ at the far zone is the same as the E_x at the dipole location due to a $\hat{\theta}$ polarized (TM) incident plane wave. Also, E_ϕ field at the far zone is the same as the E_x field at the dipole location due to a $\hat{\phi}$ polarized (TE) incident plane wave. The analysis of a plane-wave incident on a layered structure with planar material gratings was developed recently with a three-dimensional integral-equation and moment-method approach [7]–[9]. In the analysis, the displacement currents within the material blocks are discretized into sets of pulse functions and are treated as secondary sources for the scattered fields. This analysis is readily applied to find the far-zone fields due to an Hertzian dipole.

The complete field expression for the microstrip structure is in terms of a continuous plane-wave spectrum. With planar material gratings, there may exist three different propagating waves. Space waves and surface waves are similar to those in conventional microstrip structures and can be found from the method of steepest-descent and a pole-extraction method, respectively. Leaky waves are due to the periodic nature of the planar grating structure. The surface wave (bound wave) is a slow wave with normalized phase constant β/k_0 (k_0 —the free-space wave number) that increases with frequency. When frequency increases (wave length λ decreases) to a point that the condition $\beta/k_0 \geq \lambda/a - 1$ holds, this bound wave becomes a leaky wave which is a fast wave for -1 space harmonic with a complex propagation constant. The far-zone radiated fields are due to the combination of space wave and leaky waves. The energy carried by bounded surface waves that propagate laterally is considered a loss. Antenna directivity, gain, and efficiency are determined by the energy distribution among these three propagating waves. Antenna efficiency can be maximized by partial elimination of the bound surface wave within certain directions (partial band-gap). For high-efficiency antennas, directivity and gain are about the same and are determined by the energy distribution between the space and leaky waves. Leaky-wave radiation pattern is highly directive in contrast to the low directivity of the space wave. To achieve high-antenna gain, it is necessary to excite a strong leaky wave.

An example of the results for radiation from the PBG substrate (Fig. 1) is shown in Fig. 3. Significant gain enhancement is found

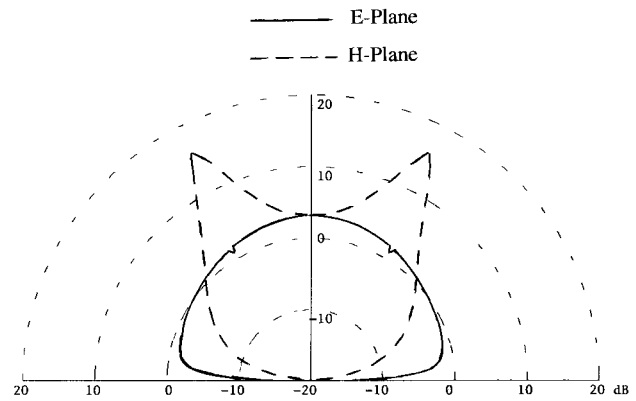

Fig. 4. Directivity pattern of an elementary dipole on a square-lattice PBG overlay. $F = 28$ GHz, $h = 1$ mm, $a = 5$ mm, $L = 3$ mm, $\epsilon_1 = 10$, $b = 1.5$ mm, $\epsilon_s = 2.2$, and the block depth is 1 mm.

(14.5 dB at 37°) in the E plane. The beam angle coincides with that of a leaky-wave mode [7], [8]. It is observed that the gain decreases and the beam angle increases with increasing ϕ angle (up to 90° , from E to H plane). As the ϕ angle approaches 90° , the leaky-wave field is much weaker than the space-wave field and no gain improvement is observed (the H-plane pattern is shown in Fig. 3). This observation is generally true for antennas on a thin PBG substrate. In contrast, for a microstrip antenna with a PBG overlay it is possible to have significant gain enhancement in the H plane (15-dB gain at a 27° beam angle), but not the E plane. The results of the directivity patterns are shown in Fig. 4. A particular plane (ϕ cut) with the strongest leaky-wave fields is determined by the arrangement of substrate and superstrate configuration. The antenna location relative to the air blocks has a significant effect on the antenna gain. Fig. 3 shows the radiation patterns for the dipole at the center of the dielectric veins and Fig. 4 for the dipole at the center of an air block. Several design guidelines can be drawn from the analysis. The thicker the air blocks are, the stronger the leaky wave and the higher the gain is. For a given frequency and material with a fixed-unit cell, larger air blocks correspond to a larger beam angle (measured from the broadside). It was observed in [8] that there may exist partial band-gaps for leaky waves. In other words, there may exist a range of directions where a leaky-wave is prohibited. This implies that the gain enhancement can be designed for a particular range of ϕ angle.

III. CONCLUSION

In this letter, we demonstrated that the gain of a printed circuit antenna can be greatly enhanced with a PBG materials either as a substrate or superstrate. Three-dimensional integral-equation solutions for a scattering problem in conjunction with the reciprocity theorem were used to determine the antenna directivity patterns. It was found that significant gain enhancement is achieved by exciting strong leaky waves through proper designs of the planar periodic material structure. It was also found that the high-gain patterns (or strong leaky waves) occur only at certain ϕ angles.

REFERENCES

- [1] E. Yablonovitch, "Photonic band-gap structures," *J. Opt. Soc. Amer. B*, vol. 10, no. 2, pp. 283–294, Feb. 1993.
- [2] E. R. Brown, C. D. Parker, and E. Yablonovitch, "Radiation properties of a planar antenna on a photonic-crystal substrate," *J. Opt. Soc. Amer. B*, vol. 10, no. 2, pp. 404–407, Feb. 1993.
- [3] T. Suzuki and P. L. Yu, "Experimental and theoretical study of dipole emission in the two-dimensional photonic band structures of the square lattice with dielectric cylinders," *J. Appl. Phys.*, vol. 79, no. 2, pp. 582–594, Jan. 1996.

- [4] N. G. Alexopoulos and D. R. Jackson, "Gain enhancement methods for printed circuit antennas," *IEEE Trans. Antennas Propagat.*, vol. AP-33, pp. 976–987, Sept. 1985.
- [5] H. Y. Yang and N. G. Alexopoulos, "Gain enhancement methods for printed circuit antennas through multiple superstrates," *IEEE Trans. Antennas Propagat.*, vol. AP-35, pp. 860–863, July 1987.
- [6] D. R. Jackson, A. A. Oliner, and A. Ip "Leaky-wave propagation and radiation for a narrow-beam multilayer dielectric structure," *IEEE Trans. Antennas Propagat.*, vol. 41, pp. 344–348, Mar. 1993.
- [7] H. Y. D. Yang, "Three-dimensional integral equation analysis of guided and leaky waves on a thin-film structure with two-dimensional material gratings," presented at *IEEE Int. Microwave Symp. Dig.*, San Francisco, CA, June 1996, pp. 723–726.
- [8] —, "Characteristics of guided and leaky waves on a thin-film structure with planar material gratings," *IEEE Trans. Microwave Theory Tech.*, to be published.
- [9] H. Y. D. Yang, N. G. Alexopoulos, and R. Diaz, "Reflection and transmission of waves from artificial-material layers made of periodic material blocks," presented at *IEEE Int. Symp. Antennas Propagat. Dig.*, Baltimore, MD, July 1996.

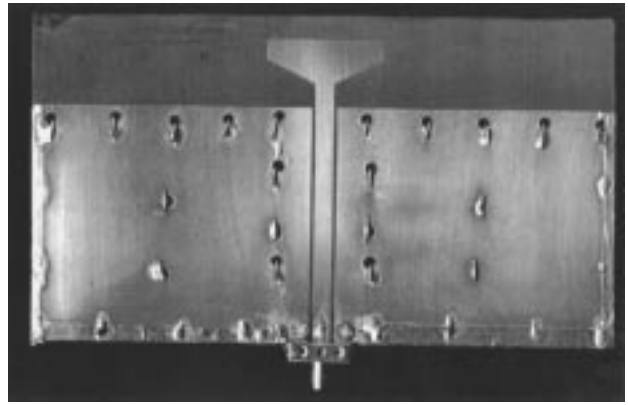

Fig. 1. Photograph of a printed tab monopole with a grounded coplanar waveguide line feed.

The Tab Monopole

J. Michael Johnson and Yahya Rahmat-Samii

Abstract—A new, compact, broadband printed antenna called the tab monopole is described. The tab monopole is a small antenna designed primarily for applications requiring antennas that can be readily integrated with printed circuit boards. The tab monopole is smaller than a quarter wavelength in size but provides a 2:1 VSWR bandwidth of greater than 50%. Measured S_{11} and gain patterns are provided.

Index Terms—Printed antennas.

I. INTRODUCTION

The recent, unprecedented increase in wireless mobile telephone usage and the subsequent explosive proliferation of related wireless mobile telecommunication systems has necessarily created a strong interest in compact, easily manufactured antennas to support these systems. The standard monopole is probably the most widely used antenna on existing mobile telecommunication applications, with the axial-mode helix coming in a close second. These two antenna types are simple to manufacture but they are not particularly easy to integrate into handset or mobile terminal cases, and they have relatively narrow operational bandwidths. Therefore, planar antennas, particularly printed circuit antennas, are of considerable interest for modern applications. While $1/4\lambda$ and $1/2\lambda$ patch antennas [1] have been used in a wide variety of systems, their size relative to the mobile terminal and handsets often makes these antennas undesirable for modern mobile applications. Attempts to produce antennas that are more compact than these standard patch designs have produced antennas such as the planar inverted F antenna (PIFA) [2], [3] and patch designs utilizing high-dielectric constant substrates. While smaller than the traditional patch antennas, these antennas generally offer no more bandwidth and can be difficult to manufacture in

Manuscript received August 7, 1996; revised September 19, 1996. This work was supported in part by ARPA Contract JFBI94-222/J4C942220.

The authors are with the Department of Electrical Engineering, University of California, Los Angeles, CA 90095 USA.

Publisher Item Identifier S 0018-926X(97)00459-6.

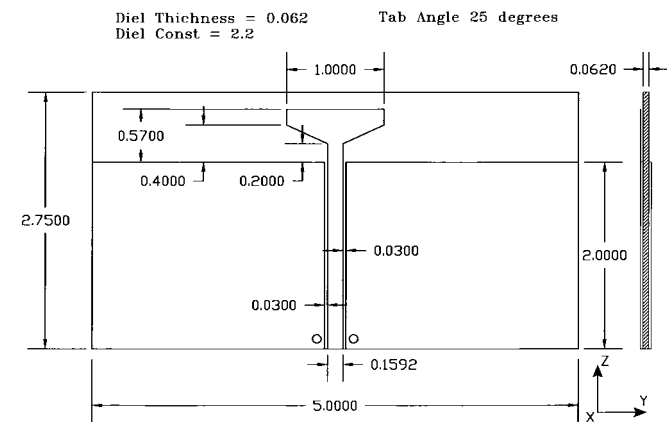

Fig. 2. Dimensions of the prototype tab monopole with dimension given in inches.

production. This paper reports on a newly developed planar antenna called the *tab monopole* featuring broadband operation that can be readily manufactured in a printed-circuit configuration.

II. TAB MONOPOLE DESIGN

The tab monopole consists of a subwavelength tapered radiating element fed by a suitable transmission line feeding structure and situated above a planar ground plane. A photograph of a printed-circuit version of a prototype tab monopole is provided in Fig. 1. The name *tab monopole* was chosen to distinguish this new antenna from existing printed-monopole designs.

The tab monopole evolved from attempts to reduce the size and increase the bandwidth provided by existing printed monopole designs. The size of the tab monopole element is approximately 0.12λ high and 0.22λ wide, with a $20\text{--}40^\circ$ taper where λ is the free-space wavelength at the design-center frequency of 2.6 GHz. Exact dimensions of a prototype 2.6-GHz tab monopole are given in inches in Fig. 2. The prototype element is fed by a grounded coplanar waveguide line. A variety of other feeding configurations are possible including microstrip, stripline, and coax. Numerous metalized vias connecting the front and back ground planes are used in the prototype tab monopole (shown in Fig. 1) to suppress spurious parallel plate modes that are known to occur in the grounded coplanar waveguide.