



## Phylogenies without Synapomorphies—A Crisis in Fish Systematics: Time to Show Some Character

RANDALL D. MOOI<sup>1</sup> & ANTHONY C. GILL<sup>2</sup>

<sup>1</sup>The Manitoba Museum, 190 Rupert Ave., Winnipeg, Manitoba R3B 0N2, Canada E-mail: rmooi@manitobamuseum.ca

<sup>2</sup>International Institute for Species Exploration and School of Life Sciences, PO Box 874501, Arizona State University, Tempe, Arizona 85287-4501, U.S.A. E-mail: gill.anthony@gmail.com

### Abstract

We contend that the move away from providing character evidence with phylogenies has diminished fish systematics and systematics in general, and amounts to a crisis. Present practices focus on solutions to matrices rather than on character homology, and rely on algorithms and statistics rather than biology to determine relationships. Optimization procedures in tree-building programs are phenetic and no longer employ homology, the original foundation of cladistics. Evidence for phylogenies is presented in a manner that obscures character conflict and makes meaningful debate difficult. The role of morphological characters has largely been reduced to their optimization and reinterpretation on the revealed “truth” of molecule-based topologies. All of this has resulted in a schism between molecular and morphological phylogeneticists. We examine several examples, focusing on Percomorpha and Gobioidae, to illustrate the shortcomings of recent approaches. We feel that phylogenetics can only move forward by recognizing that molecules are small-scale morphology; molecular data are not substantively different from larger-scale morphological data and should be treated in much the same manner. Careful investigation of homology and transparent presentation of evidence will keep our work and our science relevant. We suggest four measures that need reintroduction to phylogenetic practice in order to bring systematics back to its fundamental principles: (1) examine data quality, character distribution, and evidence; plot characters to identify and examine character conflict, and weigh evidence for homology, (2) explore the nature of character information—data become characters only after they are understood, (3) question assumptions of methods, common practice is not necessarily indicative of the ideal analysis, (4) in particular, question and investigate optimization as a method and what its impact is on character homology and the meaning of synapomorphies; use biology, not algorithms to make homology decisions.

**Key words:** molecular systematics; morphology; character conflict; optimization; Gobiiformes; Percomorpha

*Since, in principle, a data matrix containing characters for different minerals can be analyzed with PAUP to obtain a dendrogram, the application of cladistic techniques alone does not make an analysis phylogenetic.*

—Wägele, 2004

### Introduction

Over the last decade, there have probably been more fish phylogenies published than in any previous decade in the history of systematics. Worldwide projects tackling the relationships of enormous taxonomic groups such as the siluriforms and cypriniforms, along with more general surveys employing DNA barcoding, have directed substantial resources into data collection and phylogeny reconstruction. Fish systematics appears to be healthy and vibrant. So how can we suggest it is in crisis? Over the last decade or two, molecular approaches have come to dominate phylogenetics. This, of course, is not bad in and of itself—the more data, the better. But processing this volume of data has moved workers away from an intimate understanding of character distribution, homology, and the meaning of evidence. de Carvalho and Ebach (2009) similarly lamented the emphasis on quantitative analyses and the abstraction of characters and organisms alike as statistical values and models.

Solving character conflict is at the crux of systematics. Conflicting hypotheses of relationship can be addressed through: (1) a declaration of one to be true based on our own authority, (2) a re-examination of characters supporting each to discover, understand and potentially resolve conflicts, (3) the introduction of an additional source of data (either from other character complexes or with different or additional taxa) to produce yet another tree, (4) the presentation of the data in a manner where conflict is obscured and avoids scrutiny. In the pre-cladistic era, method (1) was employed. Cladistics, in its classic sense, uses method (2). Molecular systematics has generally approached conflict through methods (3) and (4). We are particularly concerned by method (4) because it hides homology assignments and their conflicts as statistical measures. This gives a false sense of confidence in a result by avoiding a careful accounting of incongruence as well as discouraging meaningful re-examination of conflict. In essence, this has led to employment of method (1) in molecular systematics in two ways: statistical programs and optimization have become the new authority figures, and when presented with two conflicting phylogenies the one including more ‘data’ (either by inclusion of more nucleotides or more taxa)—almost always the most recent—becomes the preferred topology regardless of previous evidence. This has led to an approach where phylogenies of yesterday are left with nothing to contribute to the phylogenies of today—the focus is almost solely on the final destination (the tree) rather than the journey (understanding character homology). Systematics is on a dangerous path towards irrelevancy to the remainder of biology because meaningful dialogue or assessment is no longer attempted, and is essentially impossible. Without an explicitly synapomorphy- or evidence-based approach, the vast majority of recent phylogenies will have no long-term impact.

We contend that this crisis has been precipitated by: (1) the clear trend in systematics towards a completely statistical and tree-based cladistics away from an evidence and character-based approach, (2) the apparent confusion between homology, homoplasy and the meaning of evidence, and (3) the impact of methods of analysis that are, for all intents and purposes, phenetic. We briefly examine how fish systematics has reached this point and explore the consequences of recent practices by presenting examples from work on percomorphs and gobioids, groups with which we are most familiar. This might give the appearance that we are aiming our comments at only a few practitioners when they are, in fact, only illustrative of systematics approaches that are widespread and of general concern. We end by suggesting some ways that systematics can get back on track and can continue to contribute meaningfully to phylogeny and broad evolutionary questions.

### Why we like cladistics

Nelson (2004: 128) succinctly outlined the basis of cladistics in the form of two general questions: (1) Among three taxa, what is the evidence that two are more closely related to each other than the third? and (2) if two are more closely related, what does this mean about their evolution and classification? Cladistic methods initially became generally accepted because they are logical, making use solely of apomorphies as evidence, and because they freed phylogeneticists from relying on senior authorities to determine how study organisms were related. Cladistics could do this because it demanded that evidence, homologies, be presented in an open and transparent fashion so that all interested parties could pass judgment on the results.

In recent times, the definition of the term cladistics has gradually altered to refer to any analysis that uses a “cladistic” algorithm. In response to this and his observation as quoted at the beginning of this essay, Wägele (2004) introduced the terms *phylogenetic cladistics* and *phenetic cladistics* to differentiate between studies that perform character analysis (provide explicit arguments to identify apomorphies used to construct trees, and re-examine contradictions) from those that do not. We prefer Murphy and Doyle’s (1998) introduction of the term *phylophenetics* for the latter (as antonym to *phylogenetics*), which preserves the original use of cladistics.

Hence, cladistic phylogenies are constructed based on character homology and tests of the congruence of characters. One proposed phylogeny does not test another phylogeny, it tests the hypotheses of homology of the characters upon which it is based (Nelson 1994; Williams 2004). Characters that can be hypothesized to be homologous provide the evidence for phylogenies that we recognize as synapomorphies. If the homology of characters is identified correctly, the insertion of a fourth taxon into Nelson’s (2004) set of three, above, should not alter the relative positions of the initial taxa—elegant, logical in an evolutionary sense, and stable.

If such an insertion does alter relative relationships, then a re-evaluation of the character homology should take place and be defensible.

If phylogenies are based on the discovery of character homology, or synapomorphy, this evidence must be provided in support of the tree. It was once common practice that proposed synapomorphies were provided for each node so that others could then evaluate the evidence and determine if the homologies/synapomorphies/evidence would hold up, or they could present contrasting evidence. Characters were evaluated for homology before and after analysis, although the “before” is perhaps controversial and beyond the scope of the present discussion, but regardless, these sorts of evaluations were the norm.

### **The disappearance of synapomorphies**

Given that homologies or synapomorphies are (or were) the cornerstone of cladistics, it is also interesting to note the disappearance of the term from modern phylogenetic papers. A survey of 20 papers on major groups of fishes that claimed to be cladistic published through 2007-08 revealed that half never mentioned the term synapomorphy. Only a single paper mentioned synapomorphy in the context of a character actually used by the authors, and the remainder referenced synapomorphy only in the context of citing older, morphological works. So synapomorphy seems to be disappearing as part of the lexicon of systematics, despite the universal use of so-called cladistic methods. In contrast, in the Percomorph Phylogeny symposium volume (Johnson & Anderson 1993), every paper but one (a survey of otolith morphology) discussed synapomorphies in detail, often using the term in subtitles for portions of the text. Even the lone DNA analysis discussed sequence differences in terms of synapomorphy.

Recent phylogenies, whether molecular or morphological, refer not to synapomorphies, but to % jackknife resampling, bootstrap, posterior probabilities, or other statistical measures at each node. The characters are not discussed in any detail, and no distributions are provided. Indeed, today’s emphasis on statistics as opposed to synapomorphies is perhaps best exemplified by the following: “Sixty percent jackknife support corresponds to the expected jackknife frequency for a clade supported by a single uncontradicted synapomorphy” (Simmons & Miya, 2004: 352). Rather than analyze the data directly and identify the synapomorphies, their occurrence is estimated statistically.

### **How did we get here?**

Most of what we find wrong with prevailing molecular approaches to systematics was unknowingly summarized by Šlechtová *et al.* (2007) who, without providing character evidence, presented a topology of cobitoids based on a single nuclear gene and stated (p. 1364): “Molecular genetic data can be of help for taxonomists as they show the phylogenetic lineages and their relations and thus outline the groups for which diagnostic characters have to be found.” We offer no further comment, except to suggest that such a remark illustrates the worth in considering a few aspects of the history of phylogenetic practice to explore how the different approaches and attitudes of morphologists and molecular workers have come about.

Morphologists entered the cladistic era with a basic understanding of characters, their distribution, and quality and were looking for a way to explore them more fully. The emphasis was on character homology and how phylogenies would help solve homology questions. The methods permitted the rejection of authority figures as the only source of classification, and the general spirit was one of constant enquiry into character homology and challenge of evidence.

Molecular biologists came into the cladistic era as computer algorithms were hungry for the copious data they could provide. The ever-more statistical approach and development of computationally efficient likelihood and parsimony algorithms made the mathematical search for the “best” phylogeny irresistible, despite the lack of a developed understanding of molecular characters, their quality, and distribution that would make such a phylogeny valuable. It was (is) believed that sheer numbers of characters will lead to correct results—the solution—with a gradual approach to an asymptote of stability/“truth”, following the argumentation of Sokal and Sneath (1963) for phenetic approaches. In addition, there is the perceived authority of DNA itself, and although this view is gradually being abandoned, it persists among some fish

systematists. Thacker (2009), for example, implied that molecules are not subject to the same problems of homoplasy and missing data as morphology: “morphological evidence is scantier and frequently contradictory” (p. 93) and “...relationships based on morphological data have been difficult to assemble due to the diversity of the group, the paucity of informative character data, and the homoplasy present in many morphological characters...” (p. 94). Molecules will certainly appear to be exempt from these challenges when no character analysis is presented and no real evaluation of data from one hypothesis/topology to the next is undertaken.

Initially, cladistics overthrew “the solutions” of the authority figures of Simpson, Romer, and Mayr. However, the re-focus on solutions, the computationally “best” result, through a reliance on computer algorithms has, perhaps, created a new set of authority figures: MrBayes and PAUP, along with MrModeltest, posterior probabilities, and bootstrap. Without clearly defined synapomorphies, results of these programs and supporting statistics are authoritative in the sense that no analysis is provided around which to frame a discussion—publications consist of “these were the molecules surveyed, standard procedures were followed, this is the solution.” And there is little or no challenge to the assumptions inherent in the methods themselves (e.g. models of molecular evolution, total evidence versus partitioning, molecular clock, etc).

Although we will leave rigorous interpretation of why this is the case to science historians, there are undoubtedly social pressures that have contributed. Bowler (2003) noted that professional constraints influence the directions and decisions scientists take as they begin their research programs. In today’s molecular paradigm, morphology loses out despite being no less scientific or informative (and we would argue more). Quick results with less effort (“look Mom, no monographs!”), transferable techniques from bacteria to whales, standard computerized analyses, and support from the business sector has resulted in molecular approaches pushing morphology and taxonomy out of the university milieu. We are not suggesting this is a conspiracy, but rather a consequence of group-think, where “the material of inheritance” is sold as making phylogenetic truth attainable, fancy lab machinery providing reams of data analyzed by statistical models appears more scientific, better funding and higher overhead raises institutional interest, more hires are made on that basis, eventually influencing subsequent hiring decisions. This lack of diversity creates a culture with little challenge to its direction or methods. “As a member of a research program, I will not question its core, because if I do so, I have to bear the social consequences” (Rieppel 2004: 87). And in the current atmosphere of pressure for jobs and funding, not following the “rules” can have rather severe social consequences. Apparently, editorial pressure has even contributed to the lack of focus on character evidence, as journal space is denied for such discussion along with a reluctance to include figures, with at best a relegation of character descriptions to appendices.

Regardless of whether or not you accept our interpretation of how the divergence has occurred, the result of the different tacks of morphologists (to focus on homology and characters) and of molecular workers (to focus on statistics and solutions) is that “phylogeneticists” no longer appear to share the same goals or have the same understanding of evidence.

### **Optimization is not optimal**

*For sound phylogenetic inference, the quality of the data is far more important than the quantity.*  
—Murphy and Doyle, 1998

Phylogenetics (cladistics) works on the principle of identifying synapomorphies and this involves identifying homologous features; for some, these are one and the same (Patterson 1982), for others, not (Wägele 2004). The concept of homology is complex and there are still major debates concerning its nature (Hall 1994; Williams 2004). However, hypothesized homologues are identified operationally as synapomorphies in the context of outgroup comparison and background knowledge of character distribution. Trees are constructed and, if characters have been interpreted correctly, the basic topology should remain stable regardless of the addition of characters or the addition of taxa. Optimization was used in its early applications to explore how characters might fit on a tree and how that might change our interpretation of homology. It permitted exploration of alternative character distribution and highlighted characters that might need further examination or reinterpretation.

In most molecular presentations, optimization is used to build trees. Outgroup comparison no longer plays a critical role in determining which character states support a topology. This gradual erosion of the role of outgroup comparison has come about as we have moved further from an understanding of characters themselves and as shared character states, regardless of outgroup state, are seen as evidence. Conversion of characters to matrices of 0s and 1s has changed how we think about character states. In such a matrix, if 1s are considered apomorphic, all taxa with 0s are often considered to “share” a state, when in fact they do not. 0s among taxa are not equivalent—having a 0 only means “not having 1”—which means: we have no further information. Yet, the concept of “reversals” and optimizing non-homologous states onto trees has colored our thinking that these character states provide information despite our demonstrated ignorance regarding homology. In a way, molecular data exacerbates this problem by dividing the non-homologous condition, state 0, into a series of identifiable conditions (the remaining 3 nucleotides). This makes the assumption of homology of shared non-informative states among taxa even more appealing, as the non-homologous states look more like real information than even a “0” in a binary matrix.

With the optimization approach, topologies will change with the addition of taxa as the combination of character states changes and new optimal arrangements result—what were once homologies become homoplasies and vice versa. If we understand character homology, inserting a new taxon should generally not influence the relative relationships of the original taxa. When topologies change with the addition of taxa, this is an indication that there is a misunderstanding of character homology. In effect, optimization procedures are being relied upon to “solve” issues of homology rather than relying on biology. Outgroup conditions no longer have any influence on the understanding of these flip-flopping character interpretations. Without this influence, the concept of apomorphy disappears; homology and homoplasy are one and the same. As a result, there is no difference between optimization and phenetic methods. Because every character state change is interpreted as informative, it is essentially argued that molecules do not evolve—or at least not in a way that could result in parallelism or convergence. Optimization methods deny incongruence or make it unrecognizable, and the difference between homology and homoplasy vanishes so there can be no explicit discussion or presentation of evidence regarding homology. This has led to claims that even homoplasy can contribute to phylogenetic structure (e.g., Källersjö *et al.* 1999), an idea antithetical to phylogenetic methods based on synapomorphies.

As data or taxa are added to the matrices, optimization methods necessarily shift and “reinterpret” homology and homoplasy among the states of each low CI character; the “evidence” for the topology becomes a series of *ad hoc* arguments. Nelson (2004), in a useful review of the problems inherent in optimization procedures, referred to this shifting as distortion (see also Williams & Ebach 2005). Should phylogenetic reconstruction rely on data distortion?

### **A solution is not the answer**

*When questions are given up in favor of particular answers to them, however tentatively or forcefully embraced the answers might be, so given up to that extent, too, is the spirit of enquiry.*—G. Nelson, 2004

We must get back to the enquiry and not focus so heavily on the solution. Philosophers of science have shown that “the true tree cannot be had as a result of empirical research” (Rieppel 2004: 100). The continual plea for more characters and more taxa to reach the elusive asymptote of “enough data” is telling. This suggests that we need to get more from our phylogenetic work than a solution, and that “more” is the understanding of character homology. We have become very good at creating matrices of characters and designing algorithms to produce a single branching solution from these matrices. But this infatuation with matrices and a unique solution has led us astray from character discussion, and led us to falsely assume that any data we collect yield characters useful for phylogenetic reconstruction, even homoplastic ones (Källersjö *et al.* 1999). As Rieppel (2004: 90) pointed out: “Ever more and faster algorithms can be devised to generate hypotheses of relationship and ever more statistical measures can be used to place confidence limits on those hypotheses. These do not, however, solve the basic problem of systematics, which is the nature of character hypotheses, and the problem of their critical discussion.”

Wägele (2004: 108) argued cogently that merely creating a data matrix and using existing cladistic software to produce a tree is phenetic, whereas phylogenetics requires an explicit argumentation regarding identification of apomorphies and an explanation of contradictions and re-examination of characters to discover possible sources of error. Such discussions are lacking in the large majority of molecular treatments, admitted by some molecular workers themselves: "...the issue comes down to homology which traditionally is assumed and then tested in morphological studies, but assumed and then ignored in molecular" (Buhay 2009: 101). The discussion should also involve the quality of characters based on homology assessment and distribution (Murphy & Doyle 1998; Wägele 2004). This might seem to smack of subjectivity, but removing morphological characters for which homology is not understood (e.g., numbers of scales or fin spines) is, and should be, common practice. Even in molecular circles this argumentation is used to exclude 3<sup>rd</sup> positions in codons from analysis. We suggest that all characters should be put through this argumentation, although on a character-by-character basis (some 3<sup>rd</sup> positions in codons might be informative). Internal tests of robustness (e.g., bootstrap) cannot uncover the possible errors within a data set: "Contrary evidence is to be derived from a critical discussion of character hypotheses in themselves, not merely from the reciprocal relationships among all characters" (Rieppel 2004: 89).

One should not ignore problems within a data set because an optimized mountain of data provides a solution. Although bivalent logic is not directly applicable to empirical science generally, it might be applicable to homologies and homoplasies. To paraphrase Rieppel (2004: 99): what is true today cannot be false tomorrow, hence if a statement (of homology) believed to be true yesterday (that a character was an apomorphy) is actually false (the character is a homoplasy), then an erroneous statement was made yesterday. We believe that the reason it was erroneous needs to be investigated, not merely "reinterpreted" by the blender of optimization.

Hence, the claims of Källersjö *et al.* (1999) can themselves be reinterpreted; homoplasy does not increase *phylogenetic* structure, it merely increases structure. It comes as no real surprise that adding even misunderstood data will provide a more resolved topology under optimization procedures—these procedures are phenetic and will group those taxa that are most similar, regardless of homology considerations. The unavoidable conclusion is that optimization does not produce trees based on identified homology, so is not a phylogenetic method.

### **How do we choose—is more better and newest best?**

Cladistic methods do not test phylogenies, they test homology of characters. Without characters, our phylogenies are nothing. How do we decide what phylogeny is "better" without full disclosure and analysis of evidence? Are we to just assume that the most recent is the best? We take a closer look at some examples of the problem of choice, below. Again, we note that these are weighted to fish groups that are most familiar to us and that these are illustrative and not targeted.

**Problems with percomorphs.** Smith and Wheeler (2004) and Smith and Craig (2007) examined overlapping, though not identical, sets of acanthomorph taxa that have posed substantial difficulties for phylogenetic ichthyologists. The studies used the same molecules or portions of them (12S, tRNA-Val, two fragments of 16S, H3 and 28S—the 2004 paper also looked at TMO-4c4) and the same methods and statistical measures (jackknife resampling). However, the resulting topologies, though sharing some groupings, were not the same. We are not disputing the results of these papers. But the abandonment of character-based, or evidence-based, cladistics for statistically-based trees means there is little to dispute because no evidence is provided on which to base an argument. Any conflict between the character interpretations have been obscured by the statistical presentation of putative support.

Let us assume that both papers provided equally justifiable results. To simplify comparison, we reduced the trees to include only the taxa that are shared between them. In addition, we collapsed all branches with less than 95% jackknife resampling values, resulting in remaining nodes at or very near 100% for both topologies (Fig. 1). Relative relationships among these taxa should be expected to be similar on a theoretical basis, as trees built with carefully identified homologies should result in congruent topologies.

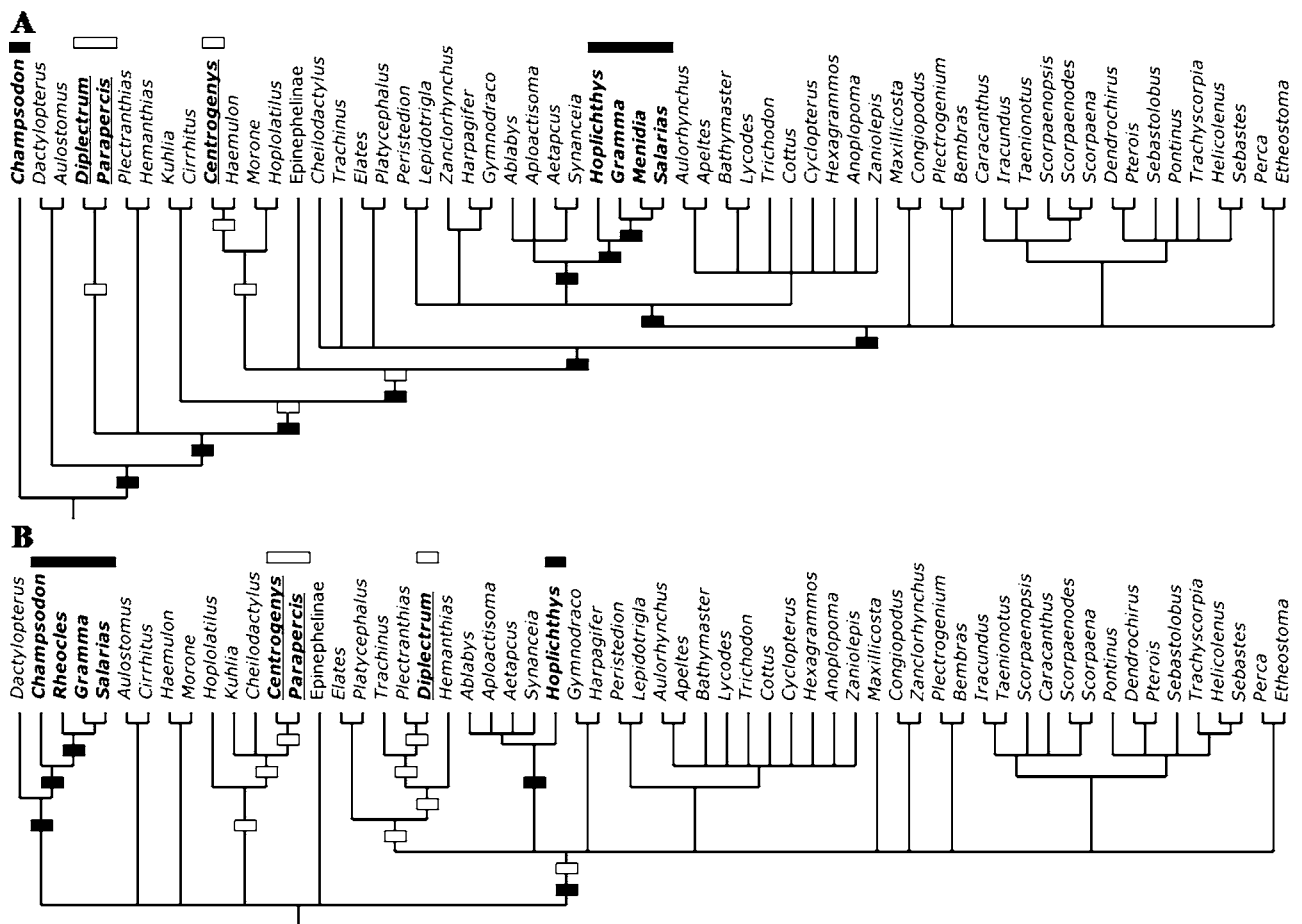
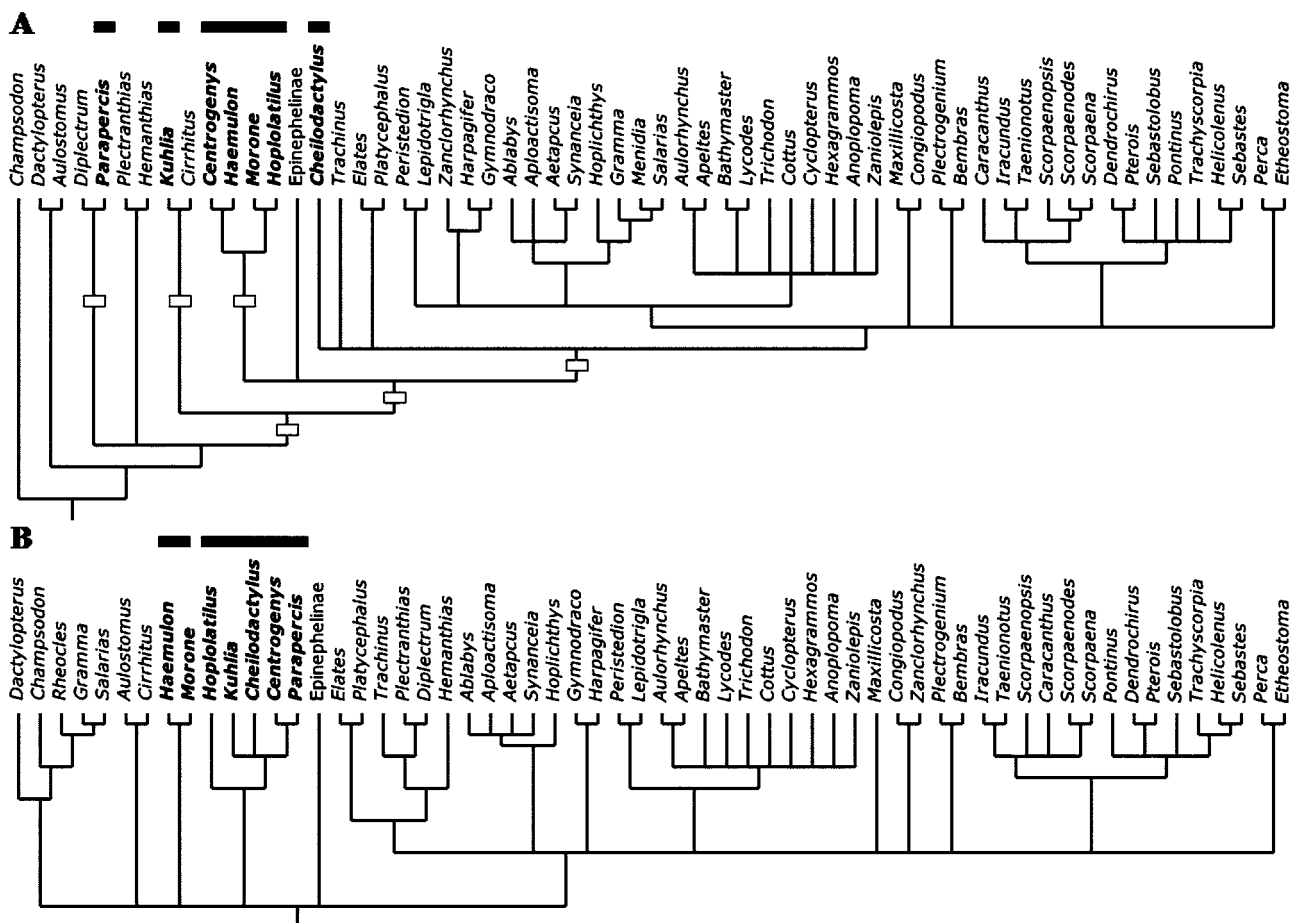

**FIGURE 1.** Simplified topologies of Smith and Wheeler (2004) (A) and Smith and Craig (2007) (B) to show differences in sister taxon assignment from one study to the other. Topologies have been pruned to include only the taxa shared by both studies and collapsed to show only nodes with jackknife resampling values of 95% or higher to facilitate comparison. Bolded taxa associated with black bars show the differences in sister taxon for the atheriniform/*Gramma*/*Salarias* clade, with *Hoplichthys* in (A) and *Champsodon* in (B). Black bars on the trees show the number of nodes between the alternate sister taxon and the clade (10 nodes away in A, 5 nodes away in B). Underlined and bolded taxa associated with open bars show the differences in sister taxon for *Parapercis*, with *Diplectrum* in (A) and *Centrogenys* in (B). Open bars on the trees show the number of nodes between the alternate sister taxon and *Parapercis* (5 nodes in A, 8 nodes in B).

There is no doubt that several intriguing groups are presented and there is some concordance between the trees, the latter to be expected given the almost identical datasets and methodologies. But there are some rather striking differences. For example, a clade common to both included a basal atheriniform (*Menidia* in one, *Rheocles* in the other), *Gramma* (basslets, a disjunct lateral-lined “serranoid” traditionally), and the blennioid *Salarias*. But where this clade fits among other taxa is perplexing. In 2004, the most closely related taxon common to both studies was *Hoplichthys*, whereas in the 2007 topology it was *Champsodon*. The 2007 choice is 10 nodes away on the 2004 tree (Fig. 1A, closed boxes), and the 2004 choice is 5 nodes away on the 2007 topology among their shared taxa (Fig. 1B, closed boxes). Similarly, *Parapercis* is paired with *Diplectrum* in 2004 and with *Centrogenys* in 2007, with the 2007 choice 5 nodes away on the 2004 topology (Fig. 1A, open boxes) and the 2004 choice 8 nodes away on the 2007 topology (Fig. 1B, open boxes). Why? What are the character distributions that have changed to make the closest included relatives so different from one analysis to the other? These questions cannot be answered from the publications, and, perhaps more surprising, were not considered worthy of investigation by the original authors.

Also troubling is the difference in the topologies regarding the taxa identified as members of the Moronoidei by Smith and Craig (2007). The “moronoid” taxa included in Smith and Wheeler (2004) were not recovered as monophyletic and are scattered over six nodes (Fig. 2). The Moronoidei was defined by Smith

and Craig (2007) as “the clade stemming from the MRCA [most recent common ancestor] of *Morone* and *Polyprion*,” a definition somewhat problematic here as Smith and Wheeler (2004) did not include the latter genus, so any change in membership is difficult to ascertain. Regardless, should there not be a careful analysis of the data to determine why these studies of similar taxa with essentially the same molecules are congruent in some areas but grossly incongruent in others?



**FIGURE 2.** Simplified topologies presented by Smith and Wheeler (2004) (A) and Smith and Craig (2007) (B) to show differences in relationship of the taxa included in the Moronoidei (bolded with black bars) in Smith and Craig. Topologies have been pruned to include only the taxa shared by both studies and collapsed to show only nodes with jackknife resampling values of 95% or higher to facilitate comparison. Open bars on the tree in (A) indicate the 6 nodes over which the moronoid taxa are distributed on this topology.

That two studies provide inconsistent results despite using similar molecules is a conundrum not unique among published molecular phylogenies. On what basis is one topology to be preferred over the other? We suggest that only by examining the synapomorphies and the distribution of characters can we assess these differences—conflicts might not be resolved, but we will gain a more thorough understanding of the characters and homology, and we will learn more about the fishes. How would molecular phylogeneticists resolve the issue of choice? Would it be through the litany of more data, more taxa, and a more recent topology? Even if we accept that the newest topology is best, how do we define the taxa when there are no characters?

**Flip-flopping *Philypnodon*.** Thacker (2009) is an excellent example of the newest-is-best approach. This molecular study combined data from ND1, ND2, COI and *cytb* sequences of gobioids and putative relatives from two older versions (Thacker 2003; Thacker & Hardman 2005) and posited a third. No critical evaluation was provided to explain some trenchant differences among the topologies presented in these publications. What characters changed polarity? What are the implications for homology? Are repeated clades among these trees even supported by the same evidence from one study to the next?



Take the case of *Philypnodon*, a genus endemic to Australia usually thrown in with the gobioid “eleotrids.” In 2005, Thacker and Hardman presented a result where this genus was sister to *Microphilypnus* with a secondary outgroup of *Leptophilypnus*, both miniature New World genera. To them, this was “consistent with two invasions of dwarf neotropical eleotrids” (p. 10). Thacker (2009) radically altered this arrangement to place *Philypnodon* among other Australian and New Zealand taxa and embedded *Leptophilypnus* and *Microphilypnus* as sister taxa among other neotropical taxa. The change was described, but not explored. Given that the same data were used in each study, what changed the topology and why? Thacker (2009) cavalierly jettisoned recent phylogenies of her own making along with the complex biogeographies they implied. Is there reason to pay any attention to this latest version? Is it likely to be replaced by yet a fourth iteration in the months to come with yet another interpretation mapped onto the new topology?

As a postscript, Thacker and Roje (2009) did indeed provide that fourth iteration of gobioid phylogeny, although it did not include *Philypnodon*. Using a subset of the larger database (including ND1, ND2, and COI, but excluding *cytb*), they explored apogonid phylogeny along with several putative relatives including eight gobioids. Given that similar data and similar outgroups are used, one might expect similar results. Gobioids are recovered as monophyletic, but gobiids were found to be sister to all other gobioids, quite different from Thacker (2009) and contradicting all morphological studies where gobiids are a higher taxon and *Rhyacichthys* is sister to all other gobioids. Should not such a result be investigated? Might *cytb* in gobioids be a case as illustrated by Chen *et al.* (2003: 279) where “the shape of a tree based on the whole set of genes can be determined by a single gene”?

In this series of papers, the claim of repeatability in molecular analyses seems not to hold up. Claims of “conformance with previous studies” supporting taxa such as the Gobiiformes (see Thacker & Roje 2009, abstract) are misleading. The conformance results from using the same molecules with the same taxa (except one with more gobioids and fewer apogonids, the other with more apogonids and fewer gobioids) and the same methods in different publications—there has been no independent testing.

### **Molecules versus morphology or with morphology?**

A worrisome and baseless movement in molecular work is to either dismiss incongruent morphology as convergence *ad hoc*, or, more recently, to employ what we call *pseudomorphology* through provision of sketchy, misinterpreted or even manufactured morphological “evidence” in support of a proposed molecular relationship. This trend might stem, in part, from editorial review procedures where molecular papers that include morphology are reviewed only for their molecular content. Here we provide some examples of the unsupported dismissal of morphological evidence and the use of pseudomorphology.

**Using molecular solutions to dismiss morphological evidence.**(1) Watch your mouth: *Stylephorus chordatus* is an odd deep-sea fish assigned to its own family. It was placed within the Lampridiformes as a derived taxon using 18 morphological characters by Olney *et al.* (1993). A molecular study by Miya *et al.* (2007) hypothesized that *Stylephorus* is closely related to the Gadiformes. Miya *et al.* (2007) proceeded to criticize and reject the morphological characters claiming that only one of four lampridiform synapomorphies involving a unique mouth protrusion mechanism was unambiguously present in *Stylephorus*, and argued that the remaining 14 characters have not been broadly surveyed or are known to vary. But Miya *et al.* (2007) offered no specific unambiguous molecular characters in support of their own hypothesis. What is the variation and distribution in their molecular data? The morphological hypothesis remains supported by what Miya *et al.* (2007) agreed is an unambiguous synapomorphy (mesethmoid posterior to the lateral ethmoids); one such synapomorphy is sufficient to support a relationship if the homology is well understood (think “hair” for mammals). Why is their molecular hypothesis exempt from a requirement of synapomorphies? Olney *et al.* (1993) provided explicit evidence that Miya *et al.* (2007) could (rightly) question. Where is the evidence in Miya *et al.* (2007)? Does this exhibit the transparency that cladistics should offer? Or does it exhibit a reliance on the authority of data-type, matrix size, and method?

As an aside, Thacker (2009: 101) suggested that “molecular data are not subject to the common morphological bias of perceived distinctiveness,” implying superiority and objectivity. Interestingly, in this

example, Olney *et al.* (1993) overlooked the morphological autapomorphies of *Stylephorus* in favor of synapomorphies that nested them within the Lampridiformes. In contrast, Miya *et al.* (2007) reinterpreted the morphology using *ad hoc* arguments to emphasize differences in order to remove *Stylephorus* from the Lampridiformes. They simultaneously ignored their own molecular results (presumably based on synapomorphies, but this cannot be substantiated) that placed the taxon with the Gadiformes and opted to erect a new order, the Stylephoriformes, emphasizing its distinctiveness. This seems a step backwards for taxonomy where autapomorphy trumps synapomorphy (phenetics).

(2) Third time is a charm: Thacker (2000) presented a morphological study of the Microdesmidae (worm gobies). Despite some possible character misinterpretation (Gill & Mooi in press), it showed quite convincingly that *Microdesmus*, *Cerdale* and *Gunnellichthys* were part of a monophyletic group based on six synapomorphies. In 2003, Thacker presented a molecular phylogeny of a subset of the gobioids where the Microdesmidae were split, with *Microdesmus* and *Cerdale* remaining sister taxa, but now considered more closely related to *Coryphopterus* and other New World gobies, whereas *Gunnellichthys* was deeply imbedded in a separate clade of Old World gobies. Despite not providing a single demonstrated synapomorphy for the molecular tree, Thacker (2003) applied *ad hoc* explanations of convergence regarding the morphological characters that had previously suggested monophyly of the Microdesmidae; in other words, why her previous statements of homology were wrong. Why would a tree with no presented evidence or character analysis be considered superior to one that provided half a dozen putative synapomorphies?

Recently, a third iteration of goby phylogeny (Thacker 2009) reunited the microdesmids as monophyletic. Despite the claim that “it is now possible to *evaluate* how well the molecular hypotheses agree with one another” (Thacker 2009: 93, our emphasis), no evaluation of the discrepancy between molecular results was provided, only the subjective assurance that the newer study was “comprehensive” (p. 97). A careful examination of character evidence would have been enlightening. In addition, Thacker (2009) used the morphology of Thacker (2000) as support for the newest molecular version because they are congruent, but did not address why the previous dismissal of the morphology by Thacker (2003) (as convergence via functional association through behavior) was no longer tenable. Will we see this explanation again if the next molecular results deny microdesmid monophyly for a second time?

(3) The eyes have it: The Pleuronectiformes have long been recognized as a cohesive unit mostly due to the unique feature of having both eyes on one side of the head (Chapleau 1993; Friedman 2008)—their monophyly has never been seriously questioned. Tetraodontiformes is another long-standing group that is consistently supported as monophyletic (Winterbottom 1974; Leis 1984). Chen *et al.* (2003) used three molecular data sets separately and in combination for a broad range of acanthomorphs challenging several morphological hypotheses, using repeatability of clades as a measure of reliability. They were unable to recover either pleuronectiforms or tetraodontiforms as monophyletic. Chen *et al.* (2003: 283) recognized this as a problem, and cited “lack of phylogenetic signal,” but without presenting character evidence, if they cannot recover these taxa as monophyletic, how do we know which of the remaining clades might be reasonable constructs? Incidentally, Smith and Wheeler (2006: fig. 2) were also unable to recover pleuronectiforms as monophyletic. These apomorphy-free trees that contradict strong morphological evidence are cases where we actually know less about the included taxa than we did before the study commenced.

We would like to point out that Chen *et al.* (2003) approached some of their proposed relationships from a character perspective. For example, a gadid/zeioid clade was supported by “a unique pattern of sequence variation” that “is not likely the result of convergence” (p. 280), a refreshing degree of character analysis unusual in molecular studies. They also began to investigate some of the assumptions regarding base compositional bias and impacts on total evidence approaches. We encourage more of these kinds of investigations into the influences of character distribution and evolutionary models. Unfortunately, the majority of their discussion involved taxon repeatability as a proxy for character support.

**Using pseudomorphology to legitimize molecular trees.** There has been a disappointing tendency in combined molecular/morphology studies towards treating morphology as a poor second cousin. Superficial, questionable, and manufactured morphological interpretations appear to be added to provide some sense of legitimacy to a molecular tree in lieu of a thorough (and perhaps difficult) evaluation of homology and a

serious attempt at increasing our understanding of the organisms. This approach is usually in the form of mapping (optimizing) morphological features on a molecule-based tree assumed to be the “solution.”

Thacker (2009) provided an example of this approach in erecting a Gobiiformes consisting of Kurtidae((Apogonidae+Pempheridae)+Gobioidei) based on molecules, but justifying the result with pseudomorphology. Morphological characters exhibiting inconsistent distribution or unlikely homology among the hypothesized relatives were suggested to provide additional evidence, while occurrence of these same features among non-included taxa was ignored. For example, kurtids and *Kurtamia* (a derived apogonid according to Prokofiev 2006) are described as sharing a condition where ribs bear expansions that form a bony sheath around the swimbladder. It is implied that this supports the gobiiform clade despite the fact that kurtids and apogonids are in separate (nonsister) suborders in the topology—the condition would necessarily be nonhomologous. Furthermore, it is noted that pempherids “also have bony sheaths on the swimbladder” (p. 99) again implying that this has some bearing on relationships when, in fact, these bony sheaths are of a completely different (nonhomologous) origin.

Thacker (2009: 99) claimed that kurtids, apogonids, gobioids, and pempherids share a dorsal gill arch feature where the 2<sup>nd</sup> epibranchial does not articulate with the 2<sup>nd</sup> pharyngobranchial, citing Johnson (1993). Johnson (1993: 18) made clear that he felt that the condition among kurtids and apogonids was not homologous with that in pempherids, and also noted that it is variably present among pempherids; he made no mention of gobioids. We have surveyed well over 100 gobioid genera, including all “basal” taxa (e.g. *Rhyacichthys*, *Protogobius*, *Terateleotris*, odontobutids), and in all cases, the 2<sup>nd</sup> epibranchial and 2<sup>nd</sup> pharyngobranchial articulate.

Male brooding and egg adhesion via micropylar filaments is cited as an additional line of evidence for common ancestry of gobioids, apogonids and kurtids (Thacker, 2009). The occurrence of this behavior and egg morphology in other groups (e.g. opisthognathids, grammatids, gobiesocids, blennioids) is overlooked. Both genera of pempherids have pelagic eggs that do not bear filaments (Connell 2007)—a “gobiiform” taxon that does not exhibit a putative gobiiform character. Similarly, sensory papillae (superficial neuromasts) on the head and body are indeed found on apogonids, gobioids and kurtids, but not on pempherids and are also found in champsodontids. Mapping morphologies on molecular topologies is far from sufficient to interpret them as homologous.

Finally, bioluminescence is suggested to link “gobiiforms” with leiognathids. Among the over 2000 species of gobioids, none is known to be bioluminescent, and light organs come and go among pempherids and apogonids. To most, this would suggest that the light organs even among apogonid taxa are nonhomologous, making them of little use as phylogenetic evidence at higher taxonomic levels. But for Thacker and Roje (2009: 744) these luminescent systems “notable for their variety” and “not present in all members of each clade” are not only homologous, but are consistent with an “underlying genetic architecture...that is differentially expressed,” an *ad hoc* tour de force. The remaining proposed “gobiiform” taxon, the kurtids, also lacks light organs, but in a remarkable non sequitur it is noted that they possess “transparent bones and musculature of the flanks, such that light may be transmitted completely through the fish” (Thacker 2009: 100); how this is related to bioluminescence and would support a leiognathid/“gobiiform” relationship remains unexplained. In addition, it is wrong (p. 94) that there is a “consensus” regarding an apogonid/gobioid relationship with Miller (1973) and Winterbottom (1993) implicated as providing morphological support; Miller (1973) mentioned apogonids only in passing and Winterbottom (1993: 409) concluded that “three taxa emerge as potentially viable candidates” as a gobioid sister group, the gobiesocids, the trachinoids, or a subset of the scorpaeniforms (particularly hoplichthyids).

Thacker (2009: fig. 2) “optimizes” three morphological characters on a molecular topology of gobioids and makes the claim that “with a comprehensive molecular phylogeny for Gobioidei, it is possible to reexamine morphological characters that have been used to diagnose families and larger gobioid groups.” But to what purpose? She found that among gobiids (her gobiids+gobionellids), number of branchiostegal rays was consistently five, that epural number varied, and that fused pelvic fins are secondarily lost in some groups. None of these conclusions is new. How has this advanced our understanding of gobioid phylogeny or character homology? These superficial approaches will not move systematics forward. Morphology needs to

be recognized as an equal partner with molecules in phylogenetic reconstruction, not merely optimized on molecule-based topologies. Methods need to be explored that can mitigate the numerical dominance of molecules in combined analyses.

### **Naming clades without synapomorphies**

There has been a recent push to provide names for the groups proposed in molecular topologies (Smith & Craig 2007). As we have demonstrated, choosing a topology upon which to hang names is problematic. We will not argue the merits or lack thereof regarding the PhyloCode here, but point out that the trees of molecular phylogeneticists necessarily produce node-based taxa because no character evidence (no apomorphies) are provided. Node-based taxa leave nothing to discuss because their membership is fluid and not based on explicit synapomorphies, and we think are not what Rosen had in mind for his “uncompromisingly cladistic approach” as cited by Smith and Craig (2007). What are Smith and Craig’s (2007) Moronoidei? How do we identify a moronoid? What are Thacker’s (2009) Gobiiformes? What excludes leiognathids from this group or includes kurtids? What makes a fish a goby versus a gobiionelly? The names themselves do not really matter, and neither does it really matter whether taxa are node-based or apomorphy-based if the phylogenies from which they are derived are defensible. But we do wish to state our opposition to any named taxon based on phylogenies that do not explicitly provide evidence. Classifications based on phylogenies without explicit evidence will be no improvement on the authoritarian classifications that cladistics has (or had) been so successful in overturning.

### **Arguments against providing evidence**

We are aware that molecular workers feel that their work provides far too many synapomorphies to show node by node. In a summary of some of the views outlined here (Mooi & Gill 2008, in press), it was this aspect that elicited the greatest response. It seemed odd that a request of scientists to show evidence in support of their hypotheses was seen as unreasonable. Is it not generally common practice in science to provide evidence that permits peer evaluation? Perhaps a molecular phylogeny provides hundreds of characters, but not until we can see how the data are distributed can it be determined which are synapomorphies. Cladistics requires an examination of character conflict and its resolution through justified reinterpretation. If molecular systematists wish to have their work considered phylogenetics and not phylophenetics, it does not seem unreasonable to request that, at the very least, the putative synapomorphies for nodes of major focus in a molecular study be analyzed (e.g. Moronoidei, Percoidei, and Scorpaenoidei in Smith & Craig 2007; Gobiiformes, Gobiidae and Gobionellidae in Thacker, 2009). We concur with Patterson that it is not the phylogenies that are important, but the evidence: “But what matters, or matters most, in systematics is looking at specimens [or sequences], as carefully and in as much detail as you can, searching for synapomorphies” (Patterson, quoted in Johnson 2000: 51).

That molecular data are made available on-line does not preclude the requirement of evidence to appear with published phylogenies. One immediate reason is the possibility of errors in on-line sources introduced through clerical, identification, or sequencing mishaps. Some molecular workers consider that “data errors are not just negligible issues anymore—they are cause for serious concern” and that “it may be necessary to issue errata or retractions for published studies that are based largely on erroneous data” (Buhay 2009: 108). If evidence is provided in the papers themselves, reviewers and readers can discover these errors. Like morphological museum specimens, on-line sequence data are a wonderful resource. And like museum specimens, sequence data contain characters but do not reveal them without effort. Sequences do not account for the alignment differences among studies, nor do they account for differences in analyses. Different molecular workers can have the same sequences but arrive at different conclusions. This demands that character evidence be presented transparently along with a hypothesized phylogeny. Morphologists would not be permitted to present a phylogeny accompanied by only a list of specimens and a methodology. Molecular and morphological hypotheses should be held to the same standard of evidence and justification of character homology. Systematics is more than its data and a topology; to be of lasting value it includes a thorough

analysis where the homology of characters is examined and tested, and where character conflict can be discovered, understood, and resolved.

## Conclusion

It should come as no surprise that we urge a careful review of methods in modern molecular systematics when pumpkin pie can be shown to be the sister taxon to a crayfish with 100% bootstrap support (Buhay 2009: 106, fig. 7). For phylogenetics to remain relevant, its practitioners need to get back to understanding the basics of cladistics: that we do not “test” phylogenies—we test assumptions of homology. The only evidence for phylogenetic relationship is homology represented as synapomorphy—presenting phylogenies without synapomorphies is not cladistics. The addition of taxa to a study should not generally alter the relative topology of the original taxa if homologies are understood; if topologies do change, characters need re-examination and not mere optimization on the new topology. Optimizations are not so much phylogenies as they are odes to algorithms, ways to explore statistics rather than ways to explore biology. Optimization does not differentiate between homology and nonhomology; resulting topologies are “solutions” to datasets that have not taken the foundations of phylogenetics into account. In our view, all of this amounts to a crisis in phylogenetic systematics.

Statistics such as jackknife resampling percentages, bootstrap values, and posterior probabilities do not allow fruitful comparison among competing hypotheses, only homologies do. It might be argued that the statistics are shorthand for the characters that support the tree. Unfortunately, no one can read the shorthand. If we want our phylogenies to be meaningful to future workers, we must present evidence clearly and transparently. Based on statistics alone, we cannot choose between the tree produced last week and the one produced this week. Put the work in an historical context—if results from last year can be ignored, it is more than likely that results from this year can safely be ignored, too. Similarly, if parts of a topology can be ignored (e.g., nonmonophyletic pleuronectiforms), then other parts of a topology can be ignored as well. Because topologies continually change with the addition of taxa and with the combination of data, there is no shelf life for molecular phylogenies or their character interpretations, such as they are.

Are molecular biologists not interested in character homology, the most important element of any phylogenetic investigation? Has the drive for a solution meant a loss of the spirit of enquiry, as Nelson (2004: 128) professed to be the case? Is character homology in molecules inherently uninteresting? Without a commitment to homology, the contribution of molecular systematists will be minimal over the long term—phylogenies depend on understanding character homology.

Cladistics in its original sense requires that choices be based on the best evidence presented as putative synapomorphies. Hence, evidence needs to be presented for evaluation and differences in homology interpretations need to be analyzed. If molecular systematists (or any systematists) are not willing to provide demonstrable evidence (synapomorphies) for their hypothesized phylogenies, then the schism between (most) morphologists and molecular systematists will persist and Murphy and Doyle’s (1998) distinction between phylogenetics and phylophenetics will deserve broader acceptance. The two approaches can then be recognized as separate and having different philosophies and goals. Those who practice phylophenetics can get on with pursuing always evasive “solutions” that obscure and ignore character conflict, while those practicing phylogenetics can continue in the spirit of enquiry and add to our understanding of homology, relationships and biology.

If morphologists and molecular systematists can find some common ground, it is through recognizing that sequences of DNA and RNA are simply morphology writ small. Ebach and Williams (2005) provided an elegant discussion where, if it is accepted that molecules are small-scale morphology, there are some basic questions to be answered: does homology exist within molecular data and, if so, should it be interpreted in the same way as homology in non-molecular studies? Are there specific molecular systematic methods that differ in their interpretation of relationship and, if not, do we require separate molecular methods? In our view, molecular and morphological data are essentially the same and should be treated in similar ways. Phylogenetics will remain coherent, relevant, and of lasting value through the universal application of detailed

examination of character conflict discovered through transparent presentation of evidence as homology (synapomorphy). This can be achieved by:

- 1) examining data quality and character distribution; plotting characters (at the very least for critical nodes) and weighing evidence for homology
- 2) exploring the nature of character information (e.g. for molecular data, is it always expressed as separate nucleotides?)
- 3) exploring assumptions of methods, do not rely on common practice as providing the ideal analysis
- 4) considering and investigating optimization as a method and what its impact is on character homology/polarization and the meaning of synapomorphies; use biology, not algorithms to make homology decisions.

## Acknowledgements

D. Buth, C. Johnston, J. Leis, Q. Wheeler and D. Williams read earlier versions of this manuscript and offered excellent advice and encouragement. Detailed discussions with M. Ebach and D. Williams helped to clarify our views on several points. Of course, we retain full responsibility for the opinions presented in this paper and do not imply their agreement. This work is based on research supported by a Natural Sciences and Engineering Research Council of Canada Discovery Grant 327844-06 (RDM) and a National Science Foundation award (U.S.A.) DEB-0541914 (ACG).

## References

- Bowler, P.J. (2003) *Evolution, the History of an Idea*. University of California Press, Berkeley, 464 pp.
- Buhay, J.E. (2009) "COI-like" sequences are becoming problematic in molecular systematic and DNA barcoding studies. *Journal of Crustacean Biology*, 29, 96–110.
- de Carvalho, M.R. & Ebach, M.C. (2009) Death of the specialist, rise of the machinist. *History and Philosophy of the Life Sciences*, 31, 467–470.
- Chapleau, F. (1993) Pleuronectiform relationships: a cladistic reassessment. *Bulletin of Marine Science*, 52, 516–540.
- Chen, W.-J., Bonillo, C. & Lecointre, G. (2003) Repeatability of clades as a criterion of reliability: a case study for molecular phylogeny of Acanthomorpha (Teleostei) with larger number of taxa. *Molecular Phylogenetics and Evolution*, 26, 262–288.
- Connell, A. (2007) Marine fish eggs and larvae from the east coast of South Africa. Available from <http://www.fisheggsandlarvae.com/> (accessed 17 March 2010).
- Ebach, M.C. & Williams, D.M. (2005) Molecular systematics is not genetics. *Rivista di biologia*, 98, 373–376.
- Friedman, M. (2008) The evolutionary origin of flatfish asymmetry. *Nature*, 454, 209–212.
- Gill, A.C. & Mooi, R.D. (In press) Character evidence for monophyly of the Microdesminae, with comments on relationships to *Schindleria* (Teleostei: Gobioidei: Gobiidae). *Zootaxa*.
- Hall, B.K. (1994) *Homology: the Hierarchical Basis of Comparative Biology*. Academic Press, New York, 483 pp.
- Källersjö, M., Albert, V.A. & Farris, J.S. (1999) Homoplasy increases phylogenetic structure. *Cladistics*, 15, 91–93.
- Johnson, G.D. (1993) Percomorph phylogeny: progress and problems. *Bulletin of Marine Science*, 52, 3–28.
- Johnson, G.D. (2000) Higher teleosts and adventures in the fish trade. In: Forey, P.L., Gardiner, B.G. & Humphries, C.J. (Eds.). Colin Patterson (1933–1998) A celebration of his life. *The Linnean*, Special Issue, 2, 39–53.
- Johnson, G.D. & Anderson, W.D. Jr. (Eds.) (1993) Proceedings of the symposium on phylogeny of Percomorpha, June 15–17, 1990, held in Charleston, South Carolina at the 70<sup>th</sup> Annual Meetings of the American Society of Ichthyologists and Herpetologists. *Bulletin of Marine Science*, 52, 1–626.
- Leis, J.M. (1984) Tetraodontiformes: relationships. In: Moser, H.G., Richards, W.J., Cohen, D.M., Fahay, M.P., Kendall, A.W. Jr. & Richardson, S.L. (Eds.). Ontogeny and systematics of fishes. *American Society of Ichthyologists and Herpetologists, Special Publication*, 1, 459–463.
- Miller, P. (1973) The osteology and adaptive features of *Rhyacichthys aspro* (Teleostei: Gobioidei) and the classification of gobioid fishes. *Journal of Zoology, London*, 171, 397–434.
- Miya, M., Holcroft, N.I., Satoh, T.P., Yamaguchi, M., Nishida, M. & Wiley, E.O. (2007) Mitochondrial genome and a nuclear gene indicate a novel phylogenetic position of deep-sea tube-eye fish (Stylephoridae). *Ichthyological Research*, 54, 323–332.

- Mooi, R.D. & Gill, A.C. (2008) Phylogenies without synapomorphies—a crisis in systematics or what we don't node—the imperative of character evidence for phylogeny reconstruction. *In: Abstracts of the 88<sup>th</sup> Meeting of the American Society of Ichthyologists and Herpetologists.*
- Mooi, R.D. & Gill, A.C. (In press) A transitional state or harmful mutation of systematic ichthyology? A reply to Chakrabarty. *Copeia*.
- Murphy, R.W. & Doyle, K.D. (1998) Phylophenetics: frequencies and polymorphic characters in genealogical estimation. *Systematic Biology*, 47, 737–761.
- Nelson, G. (1994) Homology and systematics. *In: Hall, B.K. (Ed.). Homology: The Hierarchical Basis of Comparative Biology.* Academic Press, San Diego, pp. 101–149.
- Nelson, G. (2004) Cladistics: Its arrested development. *In: Williams, D.M. & Forey, P.L. (Eds.). Milestones in Systematics.* The Systematics Association Special Volume Series 67. CRC Press, London, pp. 127–147.
- Olney, J.E., Johnson, G.D. & Baldwin, C.E. (1993) Phylogeny of lampridiform fishes. *Bulletin of Marine Science*, 52, 137–169.
- Patterson, C. (1982) Morphological characters and homology. *In: Joysey, K.A. & Friday, A.E. (Eds.). Problems of Phylogenetic Reconstruction.* Systematic Association Special Volume Number 25. Academic Press, London, pp. 21–74.
- Prokofiev, A.M. (2006) A new genus of cardinalfishes (Perciformes: Apogonidae) from the South China Sea, with a discussion of the relationships between the families Apogonidae and Kurtidae. *Journal of Ichthyology*, 46, 279–291.
- Rieppel, O. (2004) What happens when the language of science threatens to break down in systematics: a Popperian perspective. *In: Williams, D.M. & Forey, P.L. (Eds.). Milestones in Systematics.* The Systematics Association Special Volume Series 67. CRC Press, London, pp. 57–100.
- Simmons, M.P. & Miya, M. (2004) Efficiently resolving the basal clades of a phylogenetic tree using Bayesian and parsimony approaches. *Molecular Phylogenetics and Evolution*, 31, 351–362.
- Šlechtová, V., Bohlen, J. & Tan, H.H. (2007) Families of Cobitoidea (Teleostei: Cypriniformes) as revealed from nuclear genetic data and the position of the mysterious genera *Barbucca*, *Psylorhynchus*, *Serpenticobitis* and *Vaillantella*. *Molecular Phylogenetics and Evolution*, 44, 1358–1365.
- Smith, W.L. & Craig, M.T. (2007) Casting the percomorph net widely: the importance of broad taxonomic sampling in the search for the placement of serranid and percoid fishes. *Copeia*, 2007, 35–55.
- Smith, W.L. & Wheeler, W.C. (2004) Polyphyly of the mail-cheeked fishes (Teleostei: Scorpaeniformes): evidence from mitochondrial and nuclear sequence data. *Molecular Phylogenetics and Evolution*, 32, 627–646.
- Smith, W.L. & Wheeler, W.C. (2006) Venom evolution widespread in fishes: a phylogenetic road map for the bioprospecting of piscine venoms. *Journal of Heredity*, 97, 206–217.
- Sokal, R.R. & Sneath, P.H.A. (1963) *Principles of Numerical Taxonomy.* W. H. Freeman, San Francisco, 359 pp.
- Thacker, C. (2000) Phylogeny of the wormfishes (Teleostei: Gobioidei: Microdesmidae). *Copeia*, 2000, 940–957.
- Thacker, C.E. (2003) Molecular phylogeny of the gobioid fishes (Teleostei: Perciformes: Gobioidei). *Molecular Phylogenetics and Evolution*, 26, 354–368.
- Thacker, C.E. (2009) Phylogeny of Gobioidei and placement within Acanthomorpha with a new classification and investigation of diversification and character evolution. *Copeia*, 2009, 93–104.
- Thacker, C.E. & Hardman, M.A. (2005) Molecular phylogeny of basal gobioid fishes: Rhyacichthyidae, Odontobutidae, Xenisthmidae, Eleotridae (Teleostei: Perciformes: Gobioidei). *Molecular Phylogenetics and Evolution*, 37, 858–871.
- Thacker, C.E. & Roje, D.M. (2009) Phylogeny of cardinalfishes (Teleostei: Gobiiformes: Apogonidae) and the evolution of visceral bioluminescence. *Molecular Phylogenetics and Evolution*, 52, 735–745.
- Wägele, J.-W. (2004) Hennig's phylogenetic systematics brought up to date. *In: Williams, D.M. & Forey, P.L. (Eds.). Milestones in Systematics.* The Systematics Association Special Volume Series 67. CRC Press, London, pp. 101–125.
- Williams, D.M. (2004) Homologues and homology, phenetics and cladistics: 150 years of progress. *In: Williams, D.M. & Forey, P.L. (Eds.). Milestones in Systematics.* The Systematics Association Special Volume Series 67. CRC Press, London, pp. 191–124.
- Williams, D.M. & Ebach, M.C. (2005) Drowning by numbers: rereading Nelson's "Nullius in Verba". *The Botanical Review*, 71, 415–447.
- Winterbottom, R. (1974) The familial phylogeny of the Tetraodontiformes (Acanthopterygii: Pisces) as evidenced by their comparative myology. *Smithsonian Contributions to Zoology*, 155, 1–201.
- Winterbottom, R. (1993) Search for the gobioid sister group (Actinopterygii: Percomorpha). *Bulletin of Marine Science*, 52, 395–414.