

PLANNING CONSIDERATIONS FOR A ROVING ROBOT WITH ARM\*

Richard A. Lewis and Antat K. Bejczy

Guidance and Control Division  
 Jet Propulsion Laboratory  
 California Institute of Technology  
 Pasadena, California 91103

Abstract

The Jet Propulsion Laboratory is engaged in a robot research program. The program is aimed at the development and demonstration of technology required to integrate a variety of robotic functions {locomotion, manipulation, sensing and perception, decision making, and man-robot interaction) into a working robot unit operating in a real world environment and dealing with both man-made and natural objects. This paper briefly describes the hardware and software system architecture of the robot breadboard and summarizes the developments to date. The content of the paper is focused on the unique planning considerations involved in incorporating a manipulator as part of an autonomous robot system. In particular, the effects of system architecture, arm trajectory calculations, and arm dynamics and control are discussed in the context of planning arm motion in complex and changing sensory and workspace environments.

KEY TERMS: Robot system; Robot system planning; Robot breadboard architecture; Arm motion planning; Arm control; Arm dynamics; Sensors for manipulation; Manipulating in natural and constrained environment.

1.0 introduction

Autonomous goal-directed coordination of locomotion, manipulation, and sensation and perception in a semi-natural environment is the capability being sought by the JPL Robot Research Program. The initial goal of the program is to demonstrate the integration of sensory and motor functions in the autonomous performance of manipulation and locomotion tasks in response to global commands issued by an operator. The long-range goal is to develop, test, and display concepts of robot structure, system integration and operation, and machine intelligence for the design and use of adaptive autonomous machines for advanced space and planetary exploration. The JPL program utilizes results of progress obtained at other institutions engaged in robotics and artificial intelligence work reviewed in Ref. 1. (Ref. 1 contains an extensive list of related literature.) The robot breadboard itself is a mobile vehicle (similar to that used by the astronauts on the moon) equipped with a six degree-of-freedom manipulator (a modified version of the Stanford Electric Arm, see Ref. 2), a complement of sensors (TV, laser range finder, navigation and guidance sensors, tactile sensors, and, eventually, proximity sensors), and a local mini-computer in communication with remote computers, graphic displays, and operator consoles.

\*This paper presents the results of one phase of research carried out at the Jet Propulsion Laboratory, California Institute of Technology, under Contract No. NAS7-100, sponsored by the National Aeronautics and Space Administration.

In this paper, we focus on the particular planning considerations involved in incorporating a manipulator as part of a total robot system operating in a complex sensory environment and dealing with both man-made and natural objects. First the architecture of the JPL robot breadboard and then the different aspects of planning manipulator motion are discussed.

2.0 Breadboard System Architecture

The breadboard is divided into six functional subsystems: locomotion, manipulation, environment sensing and perception, computing and data handling facilities, robot executive (REX), and operator-robot interface. Each subsystem contains both hardware and software. Subsystem design is based solely on criteria of functional compatibility, performance, growth capability, and convenient interfacing. Total robot system integration will be studied experimentally and different concepts will be demonstrated in successive stages.

2.1 Breadboard Hardware

The major subsystem hardware elements are shown in Fig. 1, indicating also the physical size of the moving part of the breadboard.

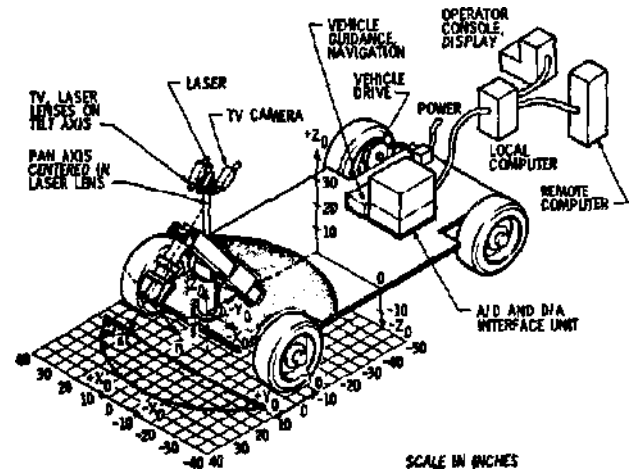

Fig. 1. Breadboard Hardware Configuration

The vehicle, on loan from Marshall Space Flight Center, provides a flat and relatively stable platform for mounting breadboard elements to be moved around in the environment. Total effective load capacity of the vehicle is about 500 pounds. Travel speed will be limited to 1 mile/hour. The vehicle has Ackerman-type double steering; the two ends can be steered in the same or opposite directions. Alternatively, one or the other end only can be steered. Each wheel is independently driven by a DC torque motor. Currently, the vehicle has only dynamic braking. The suspension has a modified

independent spring action at each wheel. Inputs to the vehicle navigation, guidance, and control system are furnished by odometers mounted on the front wheels (providing vehicle center line distance travel information), a "ruggedized" directional gyro compass (providing directional reference), and wheel drive motor tachometers (providing information on vehicle velocity).

The manipulator is a modified version of the Stanford Electric Arm described in detail in Ref. 2. It has six degrees of freedom, allowing any desired hand position and orientation in an open or slightly obscured workspace. The reachable set of points (the workspace) is within a radius of 52 inches measured from the origin of the manipulator base reference frame. (See Fig. 2.) The six joints connecting

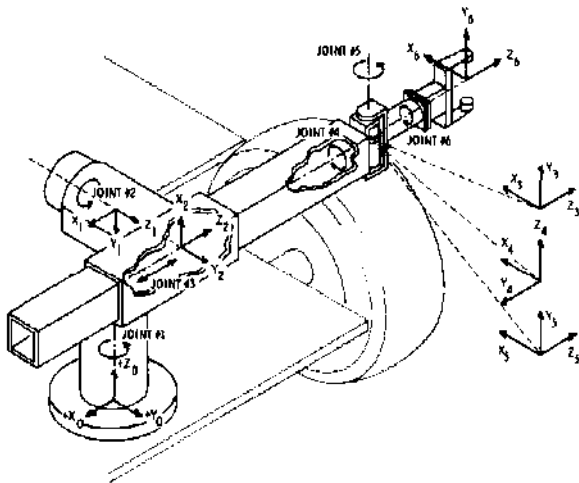

Fig. 2. Reference Frames For Link-Joint Pairs of Arm

the links from the base to the hand are in the following sequence: two rotary joints (providing shoulder azimuth and elevation action), a linear joint (providing in and out reach action), and three rotary joints (providing the wrist action). The hand is presently a simple parallel jaw mechanism. The joints are driven by permanent magnet DC torque motors geared directly to the corresponding links. Depending on the relative position of the links, the arm can handle loads of up to 5-8 pounds Earth weight. The arm servo control utilizes analog position measurements from the joint outputs and analog velocity measurements from the motor shafts. Holding torque at each joint is provided by electromagnetic brakes. The arm's structural stiffness and tight servo control can provide hand positioning accuracy within a few tenths of an inch. A suitable articulated and adaptively controlled hand will be added at a later date.

Environment sensing and perception is mainly obtained from two sources: TV cameras and laser ranging. The laser ranging device is a GaAs pulsed mode laser with fast pulse (~10 ns). The beam is pointed by a gimballed mirror and detected by a photomultiplier. Provisions are made for multipulse averaging using analog integration and variable averaging time. The sensing range is tentatively up to 150 feet. The design is based on previous JPL experiments (Ref. 3). Related data handling problems are treated in Ref. 4. The vision system consists of two identical and optically parallel vidicon

TV cameras which will provide digitized stereoscopic input to both scene analysis and operator display (Ref. 5). A 729 by 729 resolution sequential column digitizer furnishes video data for computer-rate digital picture processing and operator display. The TV cameras and laser are mounted on a pan and tilt mechanisms referenced to a common coordinate system and will be used as an integrated scene analysis subsystem. Arm-mounted proximity sensors (described in Ref. 6) and tactile sensors will at a later date augment the environment sensing and perception subsystem.

The proximity sensor is a small (about 0.3 cubic inch) electro-optical device with a small ellipsoid-shaped sensitive volume permanently focused at a distance of a few inches in front of the sensor. If this proximity sensor is mounted to an appropriate place on the hand, the sensitive volume will move with and ahead of the hand at a known distance relative to a reference point on the hand. A voltage signal will appear when the sensitive volume "touches" a solid surface as the hand approaches the surface. This voltage signal can be used to guide and control the terminal motion of the hand in direct response to sensed relative hand-object position and orientation. Of course, several proximity sensors can be mounted on the hand, providing several sensitive volumes in a known pattern around the hand and facilitating the design of a versatile conditional terminal guidance and control logic for hand motion.

The computing and data handling subsystem architecture is currently based on a remote PDP-10 in the ARPA net as an off-line computer. This will be connected to a local real time computer performing realtime robot control and I/O functions. (See Fig. 3.) The remote computer system will be used

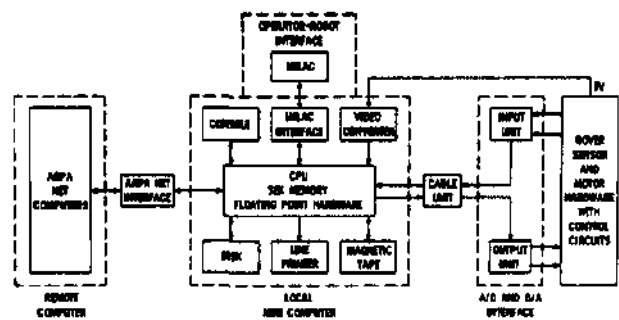

Fig. 3. Computing and Data Handling Subsystem Architecture

to process TV and laser pictures, to construct the "world model," to operate the different subsystem planning programs, and to execute top-level decision-making programs of the robot executive (REX). REX is described in detail below.

The realtime computer will interface with the robot through input and output units which contain A/D and D/A converters. A Cable Unit will contain the necessary logic devices allowing the robot to be tethered to the CPU via a 50-100 foot cable. TV data from the robot will interface directly (via the Video Converter) to the CPU through a separate cable. A disk storage unit will be used for fast, random access mass storage and will serve to store the operating

system routines, robot support programs, TV and laser pictures, and status files for the operator terminal. A magnetic tape unit will be used for performing system diagnostics and for entering operating system programs and any robot subsystem programs developed in the off-line computer. The operator console will allow operator interaction with the system and development of subsystem support programs.

The operator-robot interface functions will be performed through an IMLAC terminal connected to the realtime computer. (See Fig. 3.) During program development, the IMLAC will also be used for simulation studies. The IMLAC terminal includes a CRT display, a teletype, and a read/write cassette recorder.

## 2. Z Breadboard Software

The software system architecture is essentially hierarchical with the robot executive (REX) controlling and monitoring the various software subsystems. REX performs problem solving, interacts with the human input command structure, manages the "world model," and calls the major subsystem software modules (vehicle, arm, etc.). The major subsystems are designed to be largely independent of each other. Necessary data concerning the state of the robot and environment used by the various subsystems are furnished through the "world model,"

A Master Control Program (MCP) ties the various subsystem programs together and acts as an operating system for them. Present plans are to design the MCP in the remote computer using the mechanisms in SAIL (Stanford Artificial Intelligence Language, Refs. 7 and 8) for the creation and control of concurrent processes. Operating system modifications are also planned based on the use of the TENEX paging system (Ref. 9) which makes available interrupts of various types not incorporated into SAIL. Subsystem programs can be written in SAIL or possibly in other languages. SAIL provides easy linkages to FORTRAN and assembly languages.

The total breadboard system is of experimental nature. Thus, the software system is intended to be expandable and evolutionary.

## 3. 0 Planning Manipulator Motion

This task involves three separate efforts: system architecture effects, trajectory planning, and manipulator dynamics and control. These are, respectively, planning for manipulator motion, planning of motion, and execution of planning. Planning for manipulator motion occurs at the system level in the selection, design, and placement of robot hardware. Planning of motion involves the selection and implementation of methods of specifying particular motions and motion constraints. Execution planning deals with motion control implementation schemes. We now consider each of these three separately.

### 3. 1 System Architecture Effects

Placement of the manipulator along the center line of the vehicle about 8 inches from the front edge of the vehicle platform allows a reasonable workspace for the manipulator on the ground (which is 18 inches below the platform) while still permitting access to tools and sample storage bins near the center of the platform. This placement does, however, give rise to several motion constraints; the manipulator can

easily collide with the platform, the front edge of the platform, the wheels, and the wheel drive motors, even though the basic vehicle was modified extensively to minimize this problem.

The selection and placement of sensors give rise to additional motion constraints for the manipulator as well as allowing the manipulator to know its world. The manipulator makes use of both external and internal sensors. In the initial configuration of the robot, the primary external sensors to be used by the manipulator are the dual TV and laser range finder. These are used to determine a priori manipulator targets and are assumed to have sufficient resolution in the initial simplified robot environment for effective target specification. Later operation of the robot in richer and more perceptually complex environments rendering the sole use of these sensors open to question will be accompanied by the use of conditional arm control loops regulated by direct inputs from tactile and proximity sensors. Use of these latter devices in conjunction with an adaptive, articulated terminal effector will permit the arm to respond directly to relevant aspects of the environment.

Fig. 4a shows a proximity sensor mounted on the hand, while Fig. 4b shows the concept of proximity sensor application for terminal guidance and control of hand motion in "distance seeking" and "distance keeping" modes of operation. A more detailed treatment of proximity sensor application to manipulator control can be found in Ref. 10.

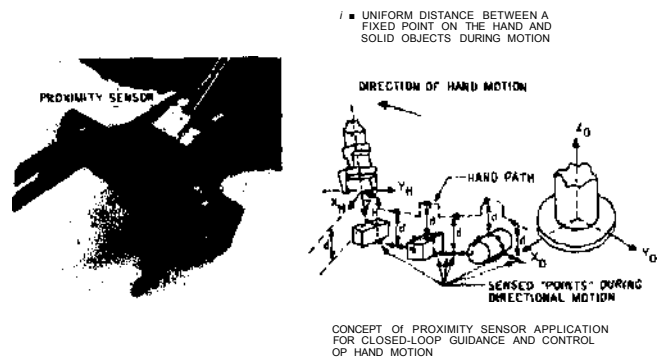

Fig- 4. Terminal Guidance and Control Of Hand Motion Using Proximity Sensing

Our robot-hand application calls for handling a variety of both regular (man-made) and irregular (natural) objects of different size and weight in various manipulative tasks. Therefore, a versatile hand-finger mechanism will ultimately be required. An articulated and adaptively controlled hand (using design and control principles similar to those applied in prosthetic hand research; see Refs. 11 and 12) will not require detailed a priori information on objects to be handled and will ease the control of many details of a grasping motion since the hand, while gripping an object and monitoring only one actuator, adapts itself "reflexively" to the shape, size, orientation, and weight of the object.

Placement of tactile and proximity sensors on the manipulator itself creates no new obstacles or additional constraints, but placement of the TV/laser head is a serious problem. The present configuration places these sensors on a mast above the arm support

post and represents a tradeoff between good viewing angle and keeping out of the way of the manipulator. Even so, it is possible for the manipulator to collide with the TV/laser head, either in normal motion or in switching from a right arm to left arm configuration. However, since the manipulator and TV/laser systems are not run simultaneously in this bread-board and the TV/laser head is mounted on a pan/tilt mechanism, these sensors can be moved out of the way.

The physical dimensions of the manipulator have been modified from the original Stanford design to permit a greater workspace on the ground. Specifically, the arm support post has been reduced by two inches and the extendable boom lengthened considerably.

The initial configuration of the robot thus provides the tools for deterministic planning of arm motion based on a priori TV/laser data with motion implementation based on feedback from internal position (pot) and rate (tach) sensors. Only primitive tactile feedback in the initial configuration allows for some conditional modification of plan. In subsequent configurations, proximity sensing and an adaptive terminal effector will permit more flexible and environment-responsive manipulator motion planning. In all cases, rover hardware design constrains manipulator motion by presenting a series of permanent obstacles to the arm.

### 3.2 Trajectory Planning

The term "trajectory" is here meant to refer to some description, partial or complete, of the path that the arm follows.

Trajectory "planning" is the activity preceding arm motion (that is, trajectory execution), the purpose of which is to constrain or otherwise define that motion. Target and environmental obstacle information are here assumed to be provided by REX and the "world model."

The degree to which the trajectory is to respond to external sensing during trajectory execution defines a continuum of trajectory planning. At one extreme is purely deterministic trajectory planning. Any external sensing to be done is performed during the planning stage; only a catastrophe halts execution of the planned path. Internal sensing is used throughout execution to maintain the adherence of actual motion to plan. Deterministic planning assumes a static world during arm motion as well as sufficient a priori knowledge and execution accuracy capabilities, and limits adaptive control. Towards the other extreme is conditional planning, the nature of which is highly dependent on the specific external sensors used. The benefits of conditional planning are flexibility of response and possible reduction of planning time at the possible cost of increased real-time computation requirements.

In the initial configuration, deterministic planning similar to that used in the Stanford hand-eye project (Refs. 13 and 14) is to be employed. Reasons include the initial lack of proximity sensing, the adequacy of TV/laser a priori information in the initial simplified environment, and the fact that most of the obstacles to arm motion are (in the initial configuration) permanent obstacles known a priori and resulting from the placement of vehicle hardware. Conditional planning is to be implemented and interfaced with existing deterministic planning at a later time.

A related distinction concerns the manner in which the trajectory plan is specified. Either a sequence of a few points or the complete time history of the arm (that is, the path) can be planned. Arm motion in a constrained workspace involves path planning.

Deterministic path planning can be performed in joint-variable space or in 3-space. In the former case, the time history of each joint is planned; it is the combination of the time histories of the joint variables that describes the motion of the arm. In the latter case, it is the motion of a particular point on the manipulator (commonly, a point on the hand) that is planned; the required joint variable time histories are derived from the plan. The advantage of planning in joint-variable space is that the plan is formulated more directly in terms of the variables to be controlled during motion. The associated disadvantage is the difficulty in determining where the various links will be during motion, a task required to guarantee avoidance of collisions with the other parts of the robot, the natural environment, or even with the arm itself.

Constraining the fingertips to describe an elliptical arc is an example of planning in 3-space. In addition to the difficulties in finding the path described by other points on other links of the arm, there is also the problem of determining the kinematic sequence of joint variable values required to implement the plan.

In the Stanford Hand-Eye Project (Refs. 13 and 14), the focus to date has been on deterministic path planning in joint-variable space, with some conditional planning. Specifically, the time histories of the joint variables have been specified in terms of sequences of polynomials with continuity of joint variable value and its first two derivatives guaranteed at the boundary points of polynomials in the polynomial sequence. The number of polynomial segments and specified motion constraints determine the total number of coefficients required for a complete quantitative specification of joint trajectory. The JPL robot research program uses a modified version of the Stanford planning algorithm.

Fig. 5a shows the time history of a joint variable described by a cubic, a quintic, and another cubic. It has been found that trajectories using polynomials of degree five or higher typically wander, as shown. This behavior appears in observation as gross extraneous motion of the arm.

Use of a quartic-cubic-quartic trajectory reveals a somewhat different problem. As shown in Fig. 5b, the desire to assure an appropriate direction of departure and approach of the terminal effector can be thwarted by the tendency of the quartic-cubic-quartic trajectory to overshoot or undershoot its endpoint values. The Stanford Hand-Eye project used both of these polynomial sequences, eliminating overshoot by special code.

A third polynomial sequence, five cubics, is being implemented for the JPL arm. This trajectory appears to minimize the "wander" and "overshoot" problems. Typically, as in Fig. 5c, there is no overshoot; wander, when it occurs, is small.

Obstacle avoidance has been implemented for the JPL arm in two ways. The first method consists of the specification of an additional safe intermediate position for the joint(s) most critically affecting arm motion in the sensitive direction. An additional

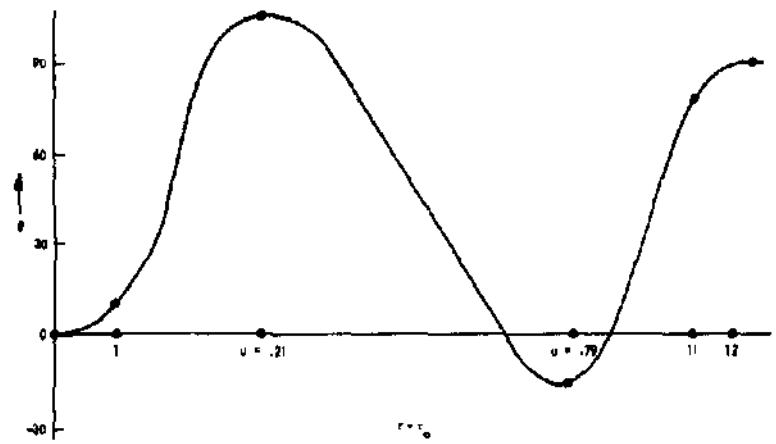

a) SEQUENCE OF CUBIC-QUINTIC-CUBIC POLYNOMIAL SEGMENTS (showing "wandering")

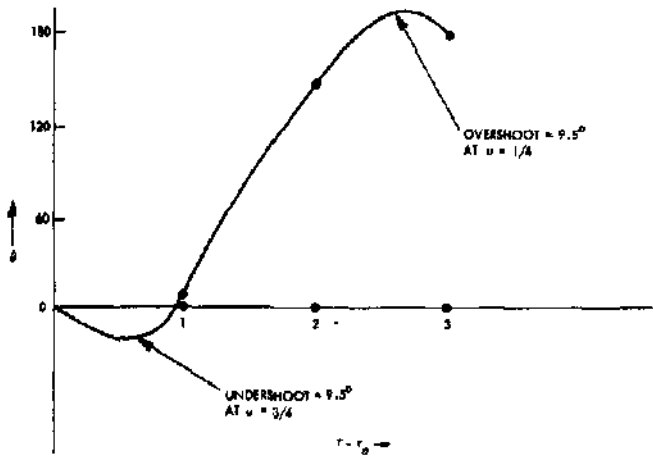

b) SEQUENCE OF QUARTIC-CUBIC-QUARTIC POLYNOMIAL SEGMENTS (showing "overshoot")

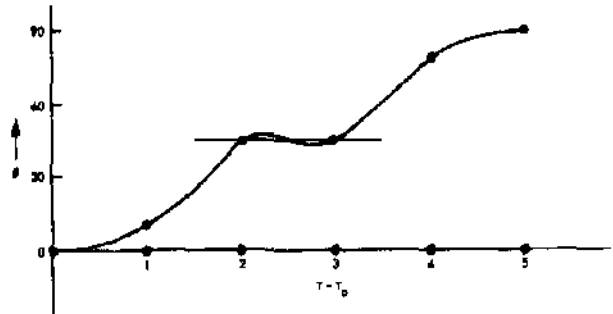

c) SEQUENCE OF FIVE CUBIC POLYNOMIAL SEGMENTS

Fig. 5. Various Polynomial Joint Trajectories

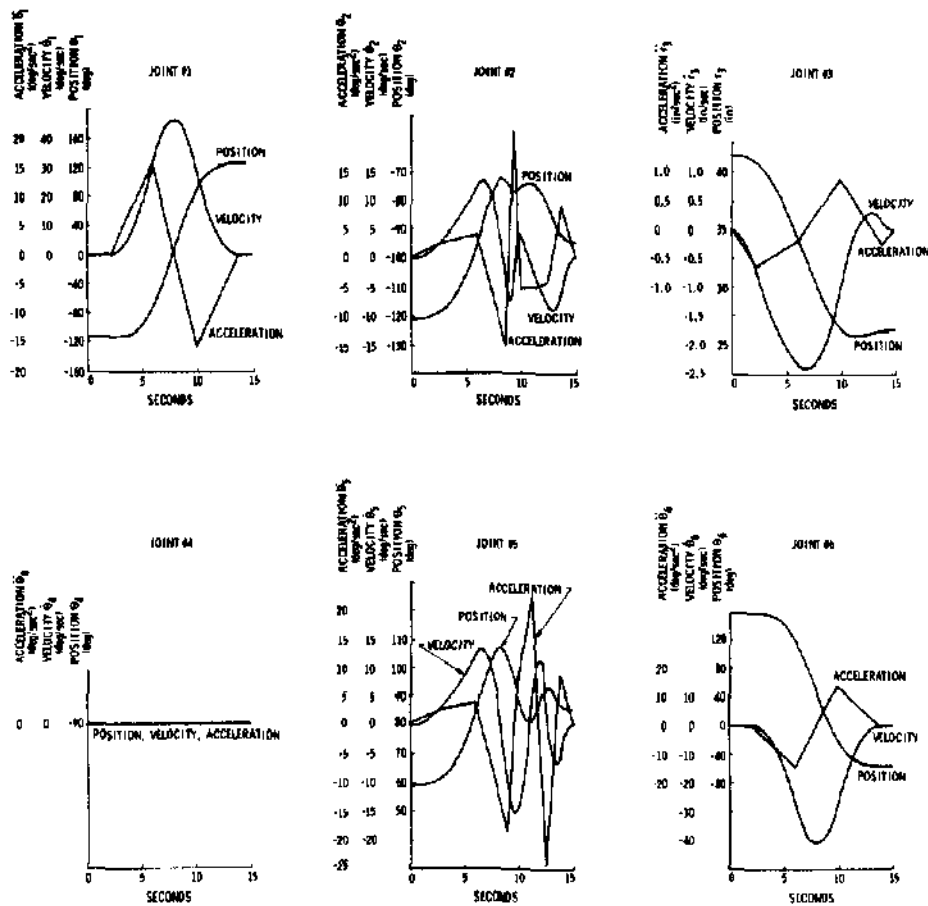

Fig. 6. Joint Variable Time Histories For a Given Task With Obstacle Avoidance

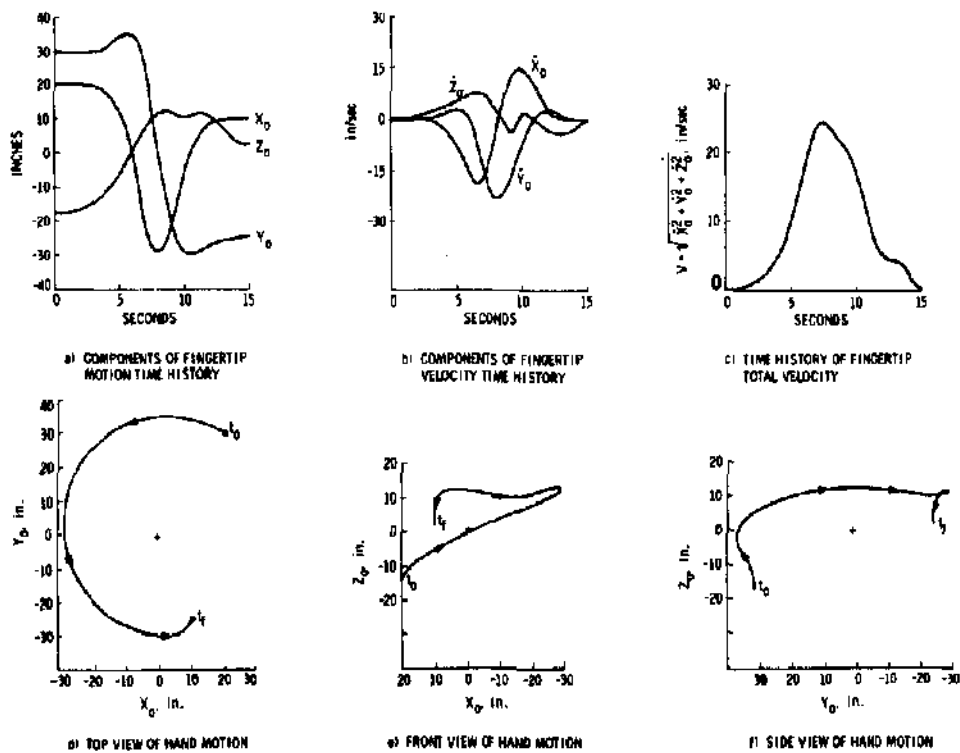

Fig. 7. Components and Projections Of Hand Motion in the Base Reference Frame (For the Same Task Shown in Fig. 6.)

cubic is required for each additional intermediate position specified. The effect of implementing this type of obstacle avoidance is shown in the trajectory illustrated in Figs. 6 and 7. Fig. 6 describes joint variable motion and Fig. 7 illustrates the projection of the same planned trajectories in the base coordinate system, as well as the associated total velocities.

As seen in Fig. 7a, the task is to lift an object from the ground (from  $x_0 = 20"$ ,  $y_0 = 30"$ ,  $z_0 = -17"$  in the base reference frame) and deposit it on the vehicle platform at  $x_0 = 10"$ ,  $y_0 = -25"$ ,  $z_0 = 2"$ . The hand orientation is also specified at both end points of the trajectory. Further, to aid the determination of the lift-off and terminal approach phases of the joint trajectories, two intermittent hand positions are also specified. As seen in Fig. 6, joint trajectories #2 and #5 contain, respectively, 9 and 8 segments due to obstacle avoidance.

A second method of obstacle avoidance is called the "freeway method." Precomputed safe trajectories (called "freeways") relating commonly accessed points are utilized in conjunction with entrance and exit "ramps" relating planned arm configurations to existing freeways. This freeway method is potentially useful in avoiding obstacles permanently affixed to the vehicle, such as the TV/laser head and support, the wheels and wheel motors, and the vehicle platform. Presently, there are 14 such permanent obstacles on the JPL robot. The freeway method can be used more frequently if the vehicle is positioned in a predetermined standard manner with respect to objects of intended manipulation.

Obstacle detection is performed by the relatively cumbersome method of checking for collision with all possible objects at various points along the trajectory. Of course, for many obstacles, the safety of several links must be examined. In the case of permanent obstacles, however, the invariant property of the relationship has been exploited to produce a series of increasingly complex tests. Thus, in many cases, simple checks of joint variable values can assure safe motion,

### 3.3 Manipulator Dynamics and Control

Execution planning deals with the specification of control laws and the design of control schemes whose implementation will assure that the physical motion of the arm will follow the desired motion.

Arm motion between distant points without prescribed continuous trajectories between the points can simply be controlled by driving each motor at some preset rate and terminating the motor drive at each joint when an appropriate signal (potentiometer or some external sensor) indicated that the joint position had reached the preset or desired terminal value. Arm trajectories planned in terms of continuous space-time coordination of joint motions, however, require that the joints be driven to comply strictly with the planned time histories of joint positions.

Several techniques are available to build a suitable position servo for each joint drive. (See Ref. 15.) An appealing computer-oriented servo technique (used in the Stanford Hand-Eye project) is to compute the required torque or force as a function of time for each joint drive, accounting also for gear ratio, efficiency, and possible nonlinearities, and construct the joint position servo loops around

the computed nominal torque or force inputs. (See Fig. 8.)

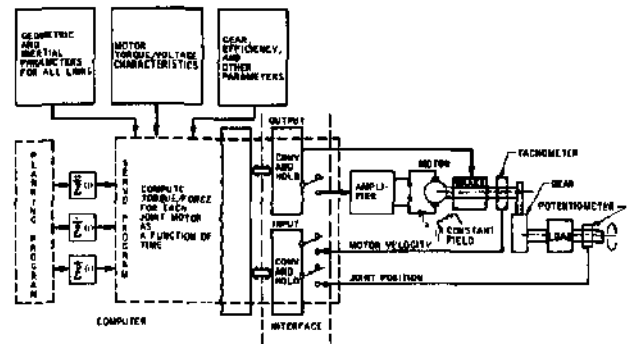

Fig. 8. Manipulator Servo Scheme

The dynamics of motion at the six joints of the arm is described by a coupled set of six second order nonlinear differential equations with time-varying (in fact, with state-varying) coefficients. There is no simple proportionality between torque (or force) acting at one joint and the acceleration of the same joint when several joints are in motion simultaneously. Even if only one joint moves at a given time, the proportionality between torque and acceleration is a complex function of the actual configuration of all links ahead of the moving joint and any load in the hand. The total variations in link inertias as seen at the joint drives due to changes in arm link configuration or load in the hand have been calculated for the JPL arm (Ref. 16) and are shown in Fig. 9.

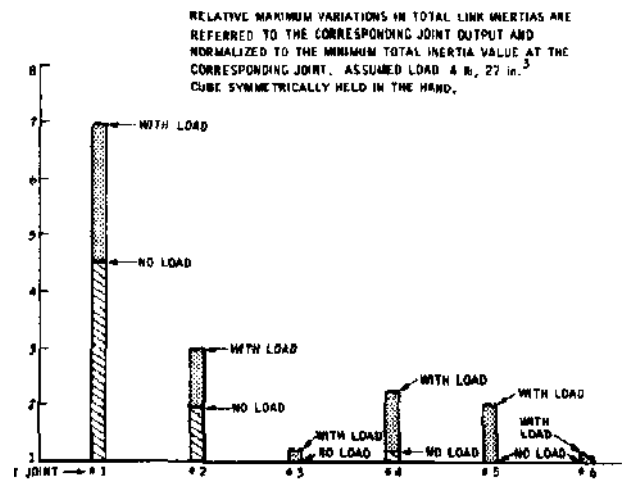

Fig. 9. Relative Maximum Variations In Total Link Inertias

In the case of simultaneous motion of several arm joints, the effective torque (or force) acting at each joint is the sum of a number of dynamic components: inertial acceleration of the joint; reaction torques or forces due to acceleration and velocity at other joints; gravity terms. The relative importance of the various dynamic components related to the planned motion displayed in Figs. 6 and 7 and computed for the actual kinematic and inertial parameters of the JPL robot research arm is illustrated

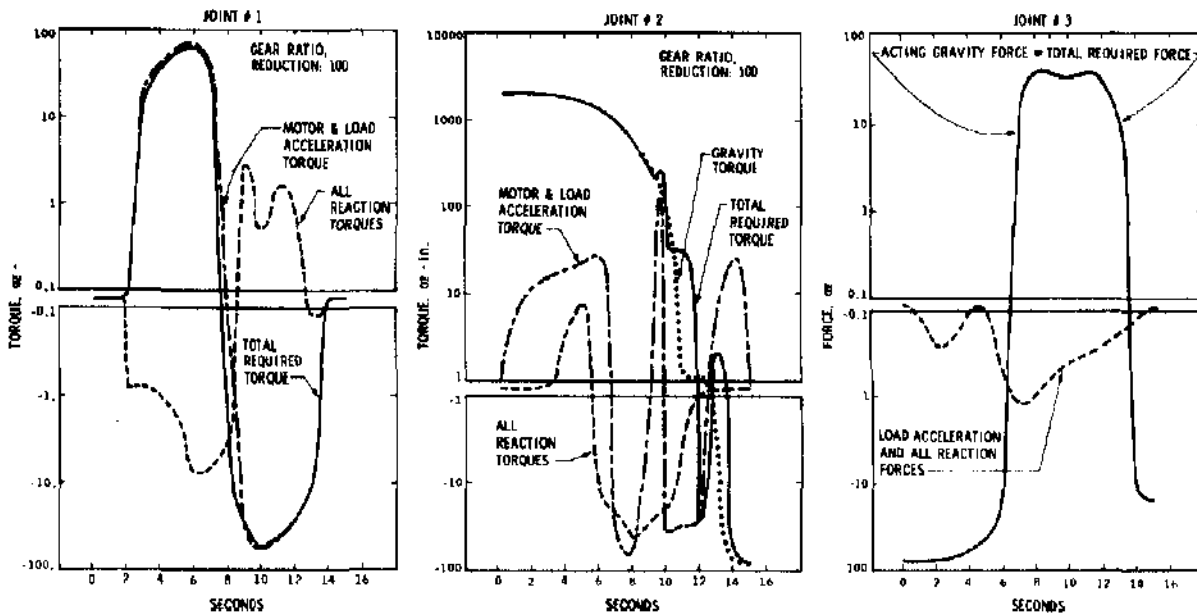

Fig. 10. Torque and Force Variations Referred to the Output (First Three Joints and for the Same Task Shown in Fig. 6)

in Fig- 10. To simplify the displayed variations, only motions and inertias of the first three joints are accounted for in the diagrams of Fig. 10. If the speed of motion (or rather, the total time of motion) is changed by a factor  $n$ , then the acceleration and velocity dependent torque and force-components of Fig. 10 can simply be scaled by a factor  $n^2$ .

Two questions are currently investigated (Ref. 16): to what extent should the reaction components be accounted for, and in what form should the state-varying dynamic coefficients be specified to ease control scheme implementation.

#### 4.0 Summary

The integration of several robot subsystems into a functioning autonomous adaptive machine requires significant planning considerations on all system levels. The JPL robot research program is currently focused on subsystem planning and design and is in the process of implementing results in hardware and software. The manipulator itself has been manufactured and is undergoing final testing. Vehicle modifications are partly completed. Construction of the TV and laser systems are in progress. Selection of complementary sensors and other hardware and acquisition of a realtime controller (the local computer) are underway. The design and building of the A/D and D/A interface units are also underway. Development of the executive and subsystem software and the master control program have begun. The future concerns are mainly related to the implementation of subsystem execution programs, planning for subsystem interaction, and the integration of subsystems into a unified robot breadboard.

The outlined considerations and results related to the design of a self-contained planning algorithm for manipulator control, when the manipulator is part of a total robot system, suggest conducting further work in two directions: direct path planning in the object space; and truly adaptive manipulator control through unification of deterministic and conditional elements in the planning algorithm.

#### Acknowledgment

The preparation of the first part of the paper benefited from discussions with several members of the JPL AI working group.

#### References

1. Bejczy, A. K. , "Machine Intelligence for Autonomous Manipulation," Proceedings of the First National Conference on Remotely Manned Systems, California Institute of Technology, Pasadena, California, September 13-15, 1972.
2. Scheinman, V. D. . "Design of a Computer Controlled Manipulator," Computer Science Department, Stanford University, Artificial Intelligence Project, Memo No. 92, June 1969, and Dobrotin, B. M. , Scheinman, V. D. , "Design of a Computer Controlled Manipulator for Robot Research," see in this Proceedings, Third International Joint Conference on Artificial Intelligence.
3. Escobal, P. R. , et al., "3D Multilateration Cone, A Precision Geodetic Measurement System," TM 33-605, Jet Propulsion Laboratory, California Institute of Technology, March 15, 1973.
4. Hong, J. P. , "Registration of Points," submitted to the IEEE Transactions on Computers.
5. Levine, M. D. , O'Handley, D. A. , Yagi, G. M. , "Computer Determination of Depth Maps," to appear in Computer Graphics and Digital Display.
6. Johnston, A. R. , "Optical Proximity Sensors for Manipulators," TM 33-612, Jet Propulsion Laboratory, California Institute of Technology, May 1, 1973.
7. Feldman, J. A. , Sproull, R. F. , "System Support for the Stanford Hand-Eye System," Proceedings of the Second International Joint Conference on Artificial Intelligence, September 1-3, 1971, London, England.



8. Feldman, J. A. , et al. , "Recent Developments in SAIL - An ALGOL-Based Language for Artificial Intelligence," 1972 FJCC Proceedings, December 5-7, 1972, Anaheim, California.
9. Bobrow, D. G. , et al. , "TENEX, A Paged Time Sharing System for the PDP-10," Proceedings, ACM Third Symposium on Operating Systems Principles, Stanford University, October 18-20, 1971.
10. Bejczy, A. K. , Johnston, A. R. , "New Techniques for Terminal Phase Control of Manipulators," TM 33- (to be published), Jet Propulsion Laboratory, California Institute of Technology.
11. Tomovic, R. , Boni, G. , "An Adaptive Artificial Hand," IRE Transactions on Automatic Control, April 1962.
12. Nightingale, J. M. , Todd, R. W. , "An Adaptively Controlled Prosthetic Hand," Engineering in Medicine, Vol. J, No. ], October 1971.
13. Paul, R. C. , "Trajectory Control of a Computer Arm," Proceedings of Second International Joint Conference on Artificial Intelligence, London, England, September 1971.
14. Paul, R. C. , "Modelling, Trajectory Calculation and Servoing of a Computer Controlled Arm," Ph.D. Thesis, Computer Science Department, Stanford University, August 1972.
15. Markiewicz, B. R. , "Analysis of the Computed Torque Drive Method and Comparison with Conventional Position Servo for a Computer-Controlled Manipulator," TM 33-601, Jet Propulsion Laboratory, California Institute of Technology, March 15, 1973.
16. Bejczy, A. K. , "Robot Arm Dynamics and Control," TM 33- (to be published), Jet Propulsion Laboratory, California Institute of Technology.