

**PÓLYA TYPE INTEGRAL INEQUALITIES: ORIGIN, VARIANTS,
PROOFS, REFINEMENTS, GENERALIZATIONS,
EQUIVALENCES, AND APPLICATIONS**

FENG QI

ABSTRACT. In the article, the author gets to the bottom of the origin of Pólya's integral inequality, plots out the development of the theory of inequalities, collects variants and proofs of Pólya's integral inequality, surveys Iyengar-Mahajani's, Agarwal-Dragomir's, Cerone-Dragomir's, and Qi's refinements, generalizations, and applications of Pólya's integral inequality, and find equivalences between these integral inequalities.

CONTENTS

1. Prologue	2
2. Preliminaries	4
2.1. The mean value theorems	4
2.2. Steffensen's and Hayashi's integral inequalities	4
3. Pólya's integral inequality: Origin, proofs, and refinement	5
3.1. The origin of Pólya's integral inequality	5
3.2. Pólya's integral inequality and its variants	9
3.3. Proofs of Pólya's integral inequality and its variants	10
3.4. Qi's refinement of Pólya type integral inequalities	15
3.5. Two equivalences	16
3.6. Remarks	17
4. Iyengar-Mahajani's integral inequality and its proofs	18
4.1. Iyengar-Mahajani's integral inequality	18
4.2. Geometric proofs of Iyengar-Mahajani's integral inequality	18
4.3. Analytic proofs of Iyengar-Mahajani's integral inequality	20
5. Refinements of Iyengar-Mahajani's integral inequality	22
5.1. Agarwal-Cerone-Dragomir's integral inequality	22
5.2. Qi's integral inequality	24
5.3. An equivalent relation	25
5.4. Remarks	26
6. Applications of Qi-Agarwal-Cerone-Dragomir's inequality	27
6.1. An applications to convex functions	27
6.2. Applications to special means	27
6.3. An application to elliptic integrals	29
7. Acknowledgements	30
References	31

2010 *Mathematics Subject Classification.* Primary 26D15; Secondary 33C75, 33E05, 41A55.

Key words and phrases. Pólya's integral inequality, Iyengar-Mahajani's integral inequality, Agarwal-Cerone-Dragomir's integral inequality, Qi's integral inequality, equivalent relation, Steffensen's inequality, Hayashi's integral inequality, Rolle's mean value theorem, Lagrange's mean value theorem, Taylor's mean value theorem with Lagrange's remainder, convex function, mean, complete elliptic integral, geometric proof, analytic proof, history, journal.

This paper was typeset using $\mathcal{A}\mathcal{M}\mathcal{S}\text{-}\mathcal{L}\mathcal{A}\mathcal{T}\mathcal{E}\mathcal{X}$.

1. PROLOGUE

In 1921, the famous mathematician Georg Pólya in [35] proved an integral inequality. This inequality may be used to estimate an integral by bounds of the first order derivative of its integrand. In 1925, G. Pólya and G. Szegő listed this integral inequality as a problem in their book [36]. See also [37, 38].

Seventeen years later, in 1938, two Indian mathematicians K. S. K. Iyengar and G. S. Mahajani respectively in [19, 28] generalized Pólya's integral inequality by geometric method.

Pólya's integral inequality, Iyengar-Mahajani's integral inequality, and their variants or simplifications often appear in textbooks of mathematical analysis, mathematical competitions or contests, graduate admission examination of mathematics in the world, and the like. See [7, 21, 22, 45], for example.

However, it is wondered that, between 1939 and 1975, there is no any new results about generalizations, extensions, refinements, and applications of Pólya's and Iyengar-Mahajani's integral inequalities to be found.

Till 1976, three Yugoslavian mathematicians, G. V. Milovanović, J. E. Pečarić, and P. M. Vasić, published respectively two joint papers [30, 43] on generalizations of Iyengar-Mahajani's integral inequality.

Twenty years passed again. In 1996, while the author in [39] refined and generalized Pólya's and Iyengar-Mahajani's integral inequalities simply and elegantly by Rolle's mean value theorem, R. P. Agarwal and S. S. Dragomir in [1] also refined and generalized Iyengar-Mahajani's integral inequality by Hayashi's integral inequality and gave some applications to special means. The results in [39] were seemingly obtained between 1993 and 1994 at the latest, since this happened after the author bought the book [23] at Beijing City in the summer holiday in 1993.

From 1997 on, there are many mathematicians, such as V. Čuljak, P. Cerone, X.-L. Cheng, Y. J. Cho, L.-H. Cui, Lj. Dedić, S. S. Dragomir, N. Elezović, I. Franjić, B.-N. Guo, Q.-D. Hao, V. N. Huy, B.-Y. Jiang, W.-M. Jin, S. S. Kim, W.-J. Liu, Z. Liu, Q.-M. Luo, Q.-A. Ngô, C. E. M. Pearce, J. Pečarić, I. Perić, J. Sándor, M. Z. Sarikaya, Y.-X. Shi, Y. Sun, N. Ujević, S. Wang, X. H. Wang, C. C. Xie, H.-T. Yang, S. J. Yang, and Y.-J. Zhang, to study Pólya-Iyengar-Mahajani type integral inequalities and their applications by utilizing various techniques, approaches and methods.

Because the World War II ruined Japan by two nuclear bombs or other reasons, the original version of [35] was difficult to be found. So almost all mathematicians did not mention G. Pólya and his paper [35] and unknowingly attributed this kind of inequalities to K. S. K. Iyengar [19].

Inequality is one of the most basic concepts in mathematics and mathematical sciences. The famous mathematician H. Bohr said: "All analysts spend half their time hunting through the literature for inequalities which they want to use and cannot prove". See [12] and [31, VII]. The Mathematical Reviews pointed out that it is not egregious no matter how to emphasize the importance of inequalities. It is impossible to image what the actuality of contemporary mathematics is if there were no inequalities such as the arithmetic-geometric-harmonic mean inequalities, Cauchy inequality, Gram inequality, Hermite-Hadamard inequality, Hölder inequality, Minkowski inequality, Steffensen's inequality, Soblev inequality, Techebycheff inequality, and Young inequality.

The development of mathematical inequality theory and applications experiences three stages, in the author's own opinion.

- (1) The first stage is before 1933. In this stage, inequalities are scattered, dispersive, and unsystematic.

- (2) The second stage began with the book [17]. Herefrom, the theory of mathematical inequalities was created formally. In this stage, a lot of books for collecting and systemizing inequalities were published on the globe, the word “inequality” was first gathered in the 1982 Mathematics Subject Classification of the American Mathematical Society, many conferences on inequalities held termly all over the world, and so on.
- (3) The third stage started from 1997. In this stage, except that publishing books and holding conferences on inequalities still keep on, the following international journals on inequalities were founded successively.
- (a) *Journal of Inequalities and Applications*, started from 1997, founded by R. P. Agarwal, and published in sequence by Gordon and Breach Science Publishers (1997–2001), Taylor & Francis (2002), Hindawi Publishing Corporation (2005–2011), and Springer Verlag (2012–now). It was ever renamed as “Archives of Inequalities and Applications” and published by the Dynamic Publishers (2003–2004);
 - (b) *Advances in Nonlinear Variational Inequalities*, started from 1998, founded by R. U. Verma, and published by the International Publications in USA;
 - (c) *Mathematical Inequalities and Applications*, started from 1998, founded by J. Pečarić, and published by the Publishing House ELEMENT in Croatia;
 - (d) *RGMA Research Report Collection*, started from 1998, founded by S. S. Dragomir, and published by Victoria University in Australia (1998–2010) and by the Austral Internet Publishing (2010–now);
 - (e) *Journal of Inequalities in Pure and Applied Mathematics*, started from 2000, founded by S. S. Dragomir, and published by Victoria University in Australia (2000–2009);
 - (f) *Journal of Mathematical Inequalities*, started from 2007, founded by A. Kufner and J. Pečarić, and published by the Publishing House ELEMENT in Croatia;
 - (g) *Advances in Inequalities and Applications*, started from 2012, founded by S. S. Dragomir, and published by the Science & Knowledge Publishing Corporation Limited.

The monographic series “Advances in Mathematical Inequalities Series” has been publishing by the Nova Science Publishers in USA.

Perhaps the following three journals are being run:

- (a) *Journal of Inequalities and Approximation Theory*, started from 2007, founded by N. Deo, and published in India;
- (b) *International Journal of Mathematical Inequalities and Applications*, started from 2007, founded by Bi-Cheng Yang, and published in India;
- (c) *International Journal of Inequalities and Applications*, started from 2007, founded by N. Seenivasagan, and published by Journals Publishing House in India.

But these three journals do not appear in the Abbreviations of Names of Serials updated in October 2010 and can not be found on the internet by Google search engine, to the best of the author’s ability.

As a companion of the above mentioned RGMA Research Report Collection, an internationally academic organization, Research Group in Mathematical Inequalities and Applications (RGMA), was founded in September 1998 at the Victoria

University, Melbourne, Australia. The logo of the RGMIA is

$$\text{RGMIA}$$

$$v(G) > \sum_{m \in G} v(m)$$

The motto of the RGMIA is “The value of the group is greater than the sum of its members”. Its current website is at <http://rgmia.org> run by the Austral Internet Publishing.

The idea of writing this work initiated on 10 November 2001 when the author was visiting the RGMIA as a Visiting Professor.

2. PRELIMINARIES

The following theorems and inequalities are well-known and famous. They are key tools of this paper.

2.1. The mean value theorems. The mean value theorems for derivative or definite integral are bridges between the local and global properties of functions and they play fundamental roles in mathematics.

Since the mean value theorems can be looked up in standard textbooks of mathematical analysis and calculus, so we recite them without proofs.

Lemma 2.1 (Rolle’s mean value theorem). *Let $f(x)$ be a function satisfying the following conditions:*

- (1) $f(x)$ is continuous on the closed interval $[a, b]$;
- (2) $f(x)$ has derivative of the first order in the open interval (a, b) ;
- (3) The values of $f(x)$ at the end points of the interval $[a, b]$ equal one another, that is, $f(a) = f(b)$.

Then there exists at least one point $\eta \in (a, b)$ such that $f'(\eta) = 0$.

Lemma 2.2 (Lagrange’s mean value theorem). *Let $f(x)$ be a function satisfying the following conditions:*

- (1) $f(x)$ is continuous on the closed interval $[a, b]$;
- (2) $f(x)$ has derivative of the first order in the open interval (a, b) .

Then there exists at least one point $\theta \in (a, b)$ such that

$$f(b) - f(a) = (b - a)f'(\theta). \quad (2.1)$$

Lemma 2.3 (Taylor’s mean value theorem with Lagrange’s remainder). *For $n \in \mathbb{N}$, let $f(x)$ be a function satisfying the following conditions:*

- (1) $f^{(i)}(x)$ for $0 \leq i \leq n$ are continuous on the closed interval $[a, b]$;
- (2) $f^{(n+1)}(x)$ exists in the open interval (a, b) .

Then for any given $x \in (a, b]$ there exists at least one point $\xi \in (a, x)$ such that

$$f(x) = f(a) + \sum_{k=1}^n \frac{f^{(k)}(a)}{k!} (x - a)^k + \frac{f^{(n+1)}(\xi)}{(n + 1)!} (x - a)^{n+1}. \quad (2.2)$$

2.2. Steffensen’s and Hayashi’s integral inequalities. The original texts of Steffensen integral inequality in [42] are quoted as follows.

Lemma 2.4 ([42]). *Assume that two functions $f(t)$ and $\phi(t)$ are integrable on $[a, b]$ such that $f(t)$ never increases and $0 \leq \phi(t) \leq 1$. Putting for abbreviation*

$$\lambda = \int_a^b \phi(t) dt. \quad (2.3)$$

Then

$$\int_{b-\lambda}^b f(t) dt \leq \int_a^b f(t)\phi(t) dt \leq \int_a^{a+\lambda} f(t) dt. \quad (2.4)$$

If $\phi(t) = 1$ or $\phi(t) = 0$ or $f(t)$ is a constant for all t , the two limits in (2.4) coincide.

The double inequality (2.4) is called Steffensen integral inequality. Its original proof was quoted in [33, pp. 311–312].

Lemma 2.5 ([18]). *Let $h : [a, b] \rightarrow \mathbb{R}$ be a non-increasing function on $[a, b]$ and $g : [a, b] \rightarrow \mathbb{R}$ an integrable function on $[a, b]$ with $0 \leq g(x) \leq A$ for all $x \in [a, b]$.*

Then

$$A \int_{b-\lambda}^b h(x) dx \leq \int_a^b h(x)g(x) dx \leq A \int_a^{a+\lambda} h(x) dx, \quad (2.5)$$

where

$$\lambda = \frac{1}{A} \int_a^b g(x) dx. \quad (2.6)$$

The double inequality (2.5) is called Hayashi's integral inequality. It is easy to see that Lemma 2.5 is a minor generalization of Lemma 2.4.

We note that J. F. Steffensen in [41] proved a very more general inequality than (2.4). This more general situation can be depicted by the following lemma.

Lemma 2.6 ([41]). *Let $h : [a, b] \rightarrow \mathbb{R}$ be a non-increasing function on $[a, b]$ and $g : [a, b] \rightarrow \mathbb{R}$ be an integrable function on $[a, b]$ with $\phi \leq g(x) \leq \Phi$ for all $x \in [a, b]$.*

Then

$$\begin{aligned} \phi \int_a^{b-\lambda} h(x) dx + \Phi \int_{b-\lambda}^b h(x) dx &\leq \int_a^b h(x)g(x) dx \\ &\leq \Phi \int_a^{a+\lambda} h(x) dx + \phi \int_{a+\lambda}^b h(x) dx, \end{aligned} \quad (2.7)$$

where

$$\lambda = \int_a^b G(x) dx, \quad G(x) = \frac{g(x) - \phi}{\Phi - \phi}, \quad \Phi \neq \phi. \quad (2.8)$$

Remark 2.1. Taking $\phi = 0$ and $\Phi = 1$ in (2.7) yields the inequality (2.4). Setting $\phi = 0$ in (2.7) derives (2.5).

Remark 2.2. For more information on Steffensen's and Hayashi's integral inequalities, please refer to [24, pp. 619–622], [25, pp. 570–572], [32, pp. 142–157] and [33, Chapter XI] and the references therein.

3. PÓLYA'S INTEGRAL INEQUALITY: ORIGIN, PROOFS, AND REFINEMENT

In this section, we shall mention the origin and history of Pólya's integral inequality, demonstrate its variants, present several proofs (including several analytic proofs and a geometric proof), and establish two equivalences.

3.1. The origin of Pólya's integral inequality. In 1921, Georg Pólya published a three pages paper [35] in old German. See Figures 3.1 to 3.3. A sketched translation in English of this paper is as follows.

A Mean Value Theorem for Functions of Multiple Variables

by

GEORG PÓLYA in Zürich, Schweiz

THE TÔHOKU MATHEMATICAL JOURNAL

Ein Mittelwertsatz für Funktionen mehrerer Veränderlichen,

von

GEORG PÓLYA in Zürich, Schweiz.

1. Wird auf einem kreisrunden Platz ein gegebenes Quantum Korn oder Sand aufgestapelt, so ist die Maximalböschung des entstehenden Haufens dann am kleinsten, wenn die Böschung überall gleich ist, d.h., wenn der Haufen die Form eines geraden Kreiskegels hat. Sehen wir zu, wohin uns die genaue Formulierung und der analytische Beweis dieser plausiblen Tatsache führen.

Die Böschung in einem Punkte einer Fläche wird durch den Tangens des spitzen Winkels gemessen, den die Tangentialebene mit der horizontal gedachten x, y -Ebene einschliesst. Ist die Axe unseres geraden Kreiskegels die z -Axe, so bilden alle seine Tangentialebenen den gleichen Winkel mit der x, y -Ebene, dessen Tangens mit T bezeichnet werden soll. Liegt die Grundfläche des Kegels in der x, y -Ebene und wird sie daselbst durch die Kreislinie

$$(1) \quad x^2 + y^2 = r^2$$

FIGURE 3.1. The first page of G. Pólya's paper

1. If we pile a certain quantity of grain or sand on a round place, then the maximal slope of the resulting pile is minimal, when the slope is everywhere equal, i.e., when the pile has the form of a cone. Let see, where the exact formulation and the analytical proof of this obvious fact will lead us.

The slope in a given point of a surface is measured by the tangent of the angle formed by the tangential plane and the horizontal (x, y) -plane. If the axis of our

2

GEORG PÓLYA:

Die Funktion $f(x, y)$ soll beide partielle Ableitungen $f'_x(x, y)$ und $f'_y(x, y)$ besitzen. Ist $f(x, y) = 0$ am Rande des Kreises

$$(1) \quad x^2 + y^2 = r^2,$$

so gibt es im Innern dieses Kreises einen Punkt ξ, η , so beschaffen, dass

$$(3) \quad \sqrt{(f'_x(\xi, \eta))^2 + (f'_y(\xi, \eta))^2} > \frac{3}{\pi r^3} \iint f(x, y) dx dy,$$

das Doppelintegral über die Fläche des Kreises (1) erstreckt.

Der Fall der Gleichheit bleibt in der Ungleichung (3) ausgeschlossen, da die Funktion

$$z = T(r - \sqrt{x^2 + y^2})$$

im Punkte $x=0, y=0$ keine partiellen Ableitungen besitzt. Die Aussage des Satzes besagt mehr als das ursprüngliche Bild, da sie nichts über das Vorzeichen von $f(x, y)$ voraussetzt.

2. Ich bezeichne mit M die obere Schranke von $\sqrt{\left(\frac{\partial f}{\partial x}\right)^2 + \left(\frac{\partial f}{\partial y}\right)^2}$.

Ich setze M als endlich voraus, da im andern Fall nichts zu beweisen ist.—Es sei x, y ein von $0, 0$ verschiedener Punkt im Innern des Kreises (1), l seine kürzeste Entfernung von der Peripherie von (1) und a, b der Fusspunkt dieser kürzesten Entfernung. Die Funktion

$$F(t) = f\left(a - \frac{a}{r}t, b - \frac{b}{r}t\right)$$

FIGURE 3.2. The second page of G. Pólya's paper

cone is the z -axis, then all the tangential planes form the same angle with the (x, y) -plane and the tangent of this angle we denote by T . If the basis of the cone lies in the (x, y) -plane, if it is bounded by the circle

$$x^2 + y^2 = r^2 \quad (3.1)$$

in a different way, if the volume is bounded from above by the surface

$$z = f(x, y), \quad (3.2)$$

$$\int_0^{2\pi} d\delta \int_0^r f(\rho \cos \delta, \rho \sin \delta) \rho d\rho < \int_0^{2\pi} d\delta \int_0^r M(r-\rho) \rho d\rho = 2\pi \frac{r^3}{6} M.$$

Letztere Ungleichung unterscheidet sich nur in der Bezeichnungsweise von der zu beweisenden (3).

Offenbar lässt sich der eben bewiesene Satz auf andere Dimensionszahlen, auf andere Gebiete und auf andere definite quadratische Formen der ersten partiellen Derivierten mit Leichtigkeit übertragen. Der einfachste analoge Satz ist wohl dieser:

Ist die Funktion $f(t)$ differenzierbar und ist

$$f(a) = f(b) = 0,$$

so ist

$$f'(\tau) > \frac{4}{(b-a)^2} \int_a^b f(t) dt$$

für mindestens einen Wert τ zwischen a und b .

Fasst man $f(t)$ als eine Geschwindigkeit auf, so erhält man folgende Tatsache: Wenn ein materieller Punkt eine Längeneinheit während einer Zeiteinheit zurücklegend von Ruhelage in Ruhelage gelangt, so erfährt er irgendwo zwischen den beiden Ruhelagen eine Beschleunigung von grösserem Betrage als 4. Die dargelegte kleine Untersuchung ist von dieser Bemerkung ausgegangen, die ihrerseits

FIGURE 3.3. The third page of G. Pólya's paper

then $f(x, y)$ vanishes in every point of the boundary of the circle (3.1) and the equality

$$\frac{\pi r^3 T}{3} = \iint f(x, y) dx dy$$

holds, where the double integral is taken over the circle (3.1). The slope in a point (x, y, z) of the surface (3.2) is measured by

$$\sqrt{\left(\frac{\partial z}{\partial x}\right)^2 + \left(\frac{\partial z}{\partial y}\right)^2}.$$

So, we come to the following theorem.

Suppose that the partial derivatives $f'_x(x, y)$ and $f'_y(x, y)$ of the function $f(x, y)$ exist. If $f(x, y) = 0$ on the boundary of the circle (3.1), then there exists an inner point (ξ, η) of (3.1) with the property

$$\sqrt{[f'_x(\xi, \eta)]^2 + [f'_y(\xi, \eta)]^2} > \frac{3}{\pi r^3} \iint f(x, y) dx dy, \quad (3.3)$$

where the double integral is taken over the circle (3.1).

Equality in (3.3) is not possible, since the function

$$z = T(r - \sqrt{x^2 + y^2})$$

is not differentiable at $(x, y) = (0, 0)$. This theorem is more general than our original problem, since we did not suppose anything about the sign of $f(x, y)$.

2. Define the minimum distance between any point (x, y) and the corresponding point (a, b) on the boundary by the variable l . Use M to denote the upper bound of

$$\sqrt{\left(\frac{\partial f}{\partial x}\right)^2 + \left(\frac{\partial f}{\partial y}\right)^2}$$

Then consider the function

$$F(t) = f\left(a - \frac{at}{r}, b - \frac{bt}{r}\right)$$

which satisfies the properties $F(0) = 0$, $F(l) = f(x, y)$, and

$$F'(t) = -\frac{\partial f}{\partial x} \frac{a}{r} - \frac{\partial f}{\partial y} \frac{b}{r} \leq \sqrt{\left(\frac{\partial f}{\partial x}\right)^2 + \left(\frac{\partial f}{\partial y}\right)^2} \sqrt{\frac{a^2}{r^2} + \frac{b^2}{r^2}} \leq M.$$

By using the mean value theorem for derivative we have

$$f(x, y) \leq lM \tag{3.4}$$

$$\dots \quad \vdots \quad \dots$$

Therefore,

$$\int_0^{2\pi} d\delta \int_0^r f(\rho \cos \delta, \rho \sin \delta) \rho d\rho < \int_0^{2\pi} d\delta \int_0^r M(r - \rho) \rho d\rho = 2\pi \frac{r^3}{6} M.$$

Obviously, it is easy and possible to generalize the the theorem to other dimensions, regions, and definite quadratic forms of the first partial derivatives. The most simple case is the following theorem.

If f is differentiable and if

$$f(a) = f(b) = 0,$$

then

$$f'(\tau) > \frac{4}{(b-a)^2} \int_a^b f(t) dt \tag{3.5}$$

for a certain τ between a and b .

If we consider f as a velocity, then we obtain the following conclusion: If a material point travels over a unit distance during a unit interval from one rest position to another, then there must be a moment, when the acceleration has the value more than 4. The presented research was inspired by this comment, which was, on the other side, prompted by a problem arising in engineering.

3.2. Pólya's integral inequality and its variants. The inequality (3.5) and different variants have been collected in many textbooks of mathematics for undergraduates.

Problem 121 in [36, p. 62], [37] and [38, p. 83] states that

Theorem 3.1. *Let $f(x)$ be differentiable and not identically a constant on the closed interval $[a, b]$ with $f(a) = f(b) = 0$. Then there exists at least one point $\xi \in [a, b]$ such that*

$$|f'(\xi)| > \frac{4}{(b-a)^2} \int_a^b f(x) dx. \tag{3.6}$$

The answer of Problem 121 in [36, p. 62] and [38, pp. 286–287] showed that the original source of Theorem 3.1 is the paper [35]. This is the only hint we found pointing to the paper [35].

Problem 3 in [22, pp. 322–323] restated Theorem 3.1 as follows.

Theorem 3.2. *Let f be a nonzero differentiable function in $[a, b]$ and $f(a) = f(b) = 0$. Then there is a point t in the interval $[a, b]$ such that*

$$|f'(t)| > \frac{4}{(b-a)^2} \int_a^b f(x) dx. \quad (3.7)$$

In [7, Exercise 12, p. 159] and [21, pp. 326–327], the following inequality is given.

Theorem 3.3. *Let $f(x)$ be two times differentiable on $[a, b]$ and $f'(a) = f'(b) = 0$. Then there exists a point $\xi \in (a, b)$ such that*

$$|f''(\xi)| \geq \frac{4}{(b-a)^2} |f(b) - f(a)|. \quad (3.8)$$

The following theorem may be regarded a generalization of Theorem 3.1.

Theorem 3.4. *Let $f(x)$ be differentiable and not identically a constant such that $f(a) = f(b) = 0$ and $|f'(x)| \leq M$ on $[a, b]$. Then*

$$\left| \int_a^b f(x) dx \right| \leq \frac{(b-a)^2 M}{4}. \quad (3.9)$$

In [27, pp. 354–355], the following theorem with stronger conditions than Theorem 3.4 was proved.

Theorem 3.5. *Let $f(x)$ have a continuous derivative on the closed unit interval $[0, 1]$ and $f(0) = f(1) = 0$. Then*

$$\left| \int_0^1 f(x) dx \right| \leq \frac{1}{4} \max_{x \in [0, 1]} |f'(x)|. \quad (3.10)$$

In [28], by a geometric argument, a strengthened form of Theorem 3.4 without equality is obtained, which can be restated as follows.

Theorem 3.6. *If $f(x)$ is differentiable and not identically zero with $f(a) = f(b) = 0$ and $|f'(x)| \leq M$ on $[a, b]$, then*

$$\left| \int_a^b f(x) dx \right| < \frac{M(b-a)^2}{4}. \quad (3.11)$$

It is worthwhile to point out that the constant $\frac{4}{(b-a)^2}$ in inequalities from (3.6) to (3.8), the constant $\frac{(b-a)^2}{4}$ in inequalities (3.9) and (3.11), and the constant $\frac{1}{4}$ in (3.10) are the best possible.

In conclusion, it is obvious that Theorems 3.1 to 3.6 can be combined into the following theorem.

Theorem 3.7. *Let $f(x)$ be differentiable and not identically constant on $[a, b]$ with $f(a) = f(b) = 0$ and $M = \sup_{x \in [a, b]} |f'(x)|$. Then*

$$\left| \int_a^b f(x) dx \right| \leq \frac{(b-a)^2}{4} M. \quad (3.12)$$

The constant $\frac{(b-a)^2}{4}$ in (3.12) is the best possible.

To the best of the author's knowledge, the inequality (3.6) is the origin of the above mentioned inequalities. For this reason, the inequality (3.6) is called Pólya's integral inequality and the inequalities from (3.2) to (3.12) are called Pólya type integral inequalities.

3.3. Proofs of Pólya's integral inequality and its variants. In this section, several proofs for Pólya type integral inequalities, which are collected, gathered, and modified from some textbooks and articles, will be presented. Most of these proofs have been published in the paper [14].

3.3.1. *Proof of Theorems 3.1 and 3.2.* This proof is quoted from [22, pp. 322–323], [36, 37], and [38, pp. 286–287].

Let $M = \sup_{a \leq x \leq b} |f'(x)|$. Then, by Lemma 2.2,

$$\begin{aligned} f(x) &= f'(t)(x-a) \leq M(x-a) & \text{for } a \leq x \leq \frac{a+b}{2}, \\ f(x) &= f'(s)(b-x) \leq M(b-x) & \text{for } \frac{a+b}{2} \leq x \leq b, \end{aligned}$$

where $a < t < x$ and $x < s < b$. The function $M(x-a)$ for $a \leq x \leq \frac{a+b}{2}$ and $M(b-x)$ for $\frac{a+b}{2} \leq x \leq b$ is not differentiable at $x = \frac{a+b}{2}$. Hence we can not have that $f(x) = M(x-a)$ for $a \leq x \leq \frac{a+b}{2}$ or $f(x) = M(b-x)$ for $\frac{a+b}{2} \leq x \leq b$ simultaneously. Thus, setting $m = \frac{a+b}{2}$,

$$\int_a^b f(x) dx < M \int_a^m (x-a) dx + M \int_m^b (b-x) dx = M \frac{(b-a)^2}{4}$$

or

$$M > \frac{4}{(b-a)^2} \int_a^b f(x) dx.$$

The proof of Theorem 3.2 is complete. \square

3.3.2. *Proof of Theorem 3.3.* This is excerpted from [21, Chapter 3, Exercise 11, p. 327].

Since $f'(a) = f'(b) = 0$, by using Lemma 2.3,

$$\begin{aligned} f\left(\frac{a+b}{2}\right) &= f(a) + \frac{f''(x_1)}{2!} \left(\frac{b-a}{2}\right)^2, \\ f\left(\frac{a+b}{2}\right) &= f(b) + \frac{f''(x_2)}{2!} \left(\frac{b-a}{2}\right)^2, \end{aligned}$$

where $x_1 \in (a, \frac{a+b}{2})$ and $x_2 \in (\frac{a+b}{2}, b)$. Further,

$$\begin{aligned} |f(b) - f(a)| &\leq \left| f(b) - f\left(\frac{a+b}{2}\right) \right| + \left| f\left(\frac{a+b}{2}\right) - f(a) \right| \\ &\leq \left(\frac{b-a}{2}\right)^2 \frac{|f''(x_1)| + |f''(x_2)|}{2!}. \end{aligned}$$

Let $f'(\xi) = \max\{|f''(x_1)|, |f''(x_2)|\}$. Then

$$\frac{|f''(x_1)| + |f''(x_2)|}{2!} \leq |f''(\xi)|.$$

The inequality (3.8) follows. \square

3.3.3. *Proof of Theorem 3.5.* This proof is quoted from [27, pp. 354–355].

Since $f(0) = f(1) = 0$, then

$$\begin{aligned} \int_0^1 f(x) dx &= \int_0^1 f(x) d(x-a) \\ &= [(x-a)f(x)]_0^1 - \int_0^1 (x-a)f'(x) dx \\ &= - \int_0^1 (x-a)f'(x) dx. \end{aligned} \tag{3.13}$$

From some property of definite integral, it follows that

$$\left| \int_0^1 f(x) dx \right| = \left| \int_0^1 (x-a)f'(x) dx \right|$$

$$\begin{aligned} &\leq \int_0^1 |x-a| |f'(x)| dx \\ &\leq \max_{0 \leq x \leq 1} |f'(x)| \int_0^1 |x-a| dx. \end{aligned}$$

For $0 \leq a \leq 1$,

$$\begin{aligned} \left| \int_0^1 f(x) dx \right| &\leq \max_{0 \leq x \leq 1} |f'(x)| \left[\int_0^a (a-x) dx + \int_a^1 (x-a) dx \right] \\ &= \max_{0 \leq x \leq 1} |f'(x)| \left[\left(ax - \frac{1}{2}x^2 \right) \Big|_0^a + \left[\left(\frac{1}{2}x^2 - ax \right) \Big|_a^1 \right] \right] \\ &= \max_{0 \leq x \leq 1} |f'(x)| \left(a^2 - a + \frac{1}{2} \right), \end{aligned}$$

that is,

$$\left| \int_0^1 f(x) dx \right| \leq \left[\left(a - \frac{1}{2} \right)^2 + \frac{1}{4} \right] \max_{0 \leq x \leq 1} |f'(x)|. \quad (3.14)$$

Since $\left(a - \frac{1}{2} \right)^2 + \frac{1}{4} \geq \frac{1}{4}$ and the inequality (3.14) is valid for all $a \in [0, 1]$, the inequality (3.5) holds. \square

3.3.4. An analytic proof of Theorem 3.6. This is a modification of the above proof of Theorem 3.2.

By Lemma 2.2,

$$\begin{aligned} M(a-x) \leq f(x) = f'(t)(x-a) \leq M(x-a) &\quad \text{for } a \leq x \leq \frac{a+b}{2}, \\ M(x-b) \leq f(x) = f'(s)(b-x) \leq M(b-x) &\quad \text{for } \frac{a+b}{2} \leq x \leq b, \end{aligned}$$

where $a < t < x$ and $x < s < b$.

The functions $\pm M(x-a)$ for $a \leq x \leq \frac{a+b}{2}$ and $\pm M(b-x)$ for $\frac{a+b}{2} \leq x \leq b$ are not differentiable at $x = \frac{a+b}{2}$. Hence we can not have that $f(x) = \pm M(x-a)$ for $a \leq x \leq \frac{a+b}{2}$ or $f(x) = \pm M(b-x)$ for $\frac{a+b}{2} \leq x \leq b$ simultaneously. Thus, setting $m = \frac{a+b}{2}$,

$$\int_a^b f(x) dx < M \int_a^m (x-a) dx + M \int_m^b (b-x) dx = M \frac{(b-a)^2}{4}$$

and

$$\int_a^b f(x) dx > M \int_a^m (a-x) dx + M \int_m^b (x-b) dx = -M \frac{(b-a)^2}{4}.$$

The proof of Theorem 3.6 is complete. \square

3.3.5. A geometric proof of Theorem 3.6. This is the original proof in [28] by G. S. Mahajani.

Let A and B be the points $(a, 0)$ and $(b, 0)$ and let K be the point $\left(\frac{1}{2}(a+b), \frac{1}{2}(b-a)M \right)$ so that KAB is an isosceles triangle with $\angle KAB = \angle KBA = \arctan M$. Under the given conditions, the curve $AB : y = f(x)$ must lie within the triangle. See Figure 3.4. The area of the triangle equals $\frac{(b-a)^2}{4}M$, while the left-hand side of (3.11) gives the area of the curve $AB : y = f(x)$. Hence the inequality (3.11) is proved. \square

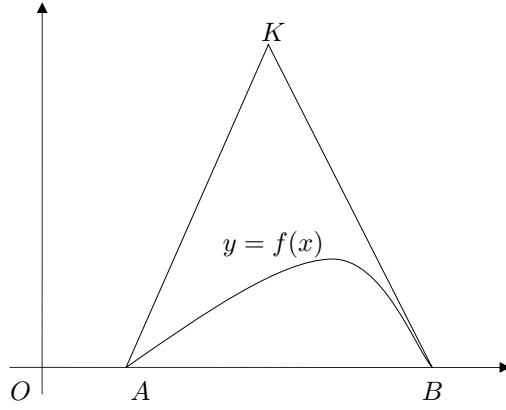

FIGURE 3.4.

3.3.6. *The first proof of Theorem 3.7.* Constructing two functions

$$L(x) = \begin{cases} M(x - a), & x \in [a, c], \\ M(b - x), & x \in [c, b] \end{cases} \quad (3.15)$$

and

$$l(x) = \begin{cases} M(a - x), & x \in [a, d], \\ M(x - b), & x \in [d, b], \end{cases} \quad (3.16)$$

where $c \in [a, b]$ and $d \in [a, b]$ are arbitrary.

By Lemma 2.2, it is easy to see that

$$l(x) \leq f(x) \leq L(x),$$

hence,

$$\int_a^b l(x) \, dx \leq \int_a^b f(x) \, dx \leq \int_a^b L(x) \, dx, \quad (3.17)$$

that is,

$$-M \left[d^2 - (a+b)d + \frac{a^2 + b^2}{2} \right] \leq \int_a^b f(x) \, dx \leq M \left[c^2 - (a+b)c + \frac{a^2 + b^2}{2} \right]. \quad (3.18)$$

It is not difficult to reveal that the function

$$h(x) \triangleq x^2 - (a+b)x + \frac{a^2 + b^2}{2} \quad (3.19)$$

for $x \in [a, b]$ attains its unique minimum $\frac{(b-a)^2}{4}$ at the point $x = \frac{a+b}{2} \in [a, b]$. Thus,

$$-\frac{(b-a)^2 M}{4} \leq \int_a^b f(x) \, dx \leq \frac{(b-a)^2 M}{4} \quad (3.20)$$

and understand that the constant $\frac{(b-a)^2}{4}$ in (3.20) is the best possible. \square

3.3.7. *The second proof of Theorem 3.7.* Properties of definite integral and integration-by-part give

$$\begin{aligned} \left| \int_a^b f(x) \, dx \right| &= \left| \int_a^b f(x) \, d(x-r) \right| \\ &= \left| [(x-r)f(x)] \Big|_a^b - \int_a^b (x-r)f'(x) \, dx \right| \end{aligned}$$

$$\begin{aligned}
&= \left| \int_a^b (x-r)f'(x) dx \right| \\
&\leq \int_a^b |x-r||f'(x)| dx \\
&\leq M \int_a^b |x-r| dx,
\end{aligned}$$

where r is an arbitrary real number.

Direct computation shows that the function $g(r) = \int_a^b |x-r| dx$ has a minimum $\frac{(b-a)^2}{4}$ when r takes the value $\frac{a+b}{2} \in [a, b]$, thus inequality (3.12) follows and the constant $\frac{(b-a)^2}{4}$ in inequality (3.12) is the best possible. \square

3.3.8. *The third proof of Theorem 3.7.* From $f(a) = f(b) = 0$, it is deduced that $f'(x) \not\equiv 0$ can not keep the same sign in (a, b) . As a result of this, integrating by part and utilizing related properties of definite integral leads to

$$\begin{aligned}
\left| \int_a^b f(x) dx \right| &= \left| [xf(x)]_a^b - \int_a^b xf'(x) dx \right| \\
&= \left| \int_a^b xf'(x) dx \right| \\
&= \left| \int_a^b (x-c)f'(x) dx + c \int_a^b f'(x) dx \right| \\
&= \left| \int_a^b (x-c)f'(x) dx \right| \\
&\leq \int_a^b |x-c| \cdot |f'(x)| dx \\
&\leq M \int_a^b |x-c| dx \\
&= M \left[c^2 - (a+b)c + \frac{a^2 + b^2}{2} \right],
\end{aligned}$$

where $c \in [a, b]$. From the conclusion that the function $h(x)$ defined by (3.19) attains its minimum $\frac{(b-a)^2}{4}$ at $x = \frac{a+b}{2} \in [a, b]$, Theorem 3.7 follows. \square

3.3.9. *The fourth proof of Theorem 3.7.* Let $g(x) = \int_a^x f(t) dt$ on $[a, b]$. Then $g(a) = 0$ and $g(b) = \int_a^b f(t) dt$. By Lemma 2.3, for $c \in [a, b]$, it follows that

$$\begin{aligned}
g(c) &= g(a) + g'(a)(c-a) + \frac{g''(\xi_1)}{2!}(c-a)^2 \\
&= f(a)(c-a) + \frac{f'(\xi_1)}{2!}(c-a)^2 \\
&= \frac{f'(\xi_1)}{2}(c-a)^2
\end{aligned} \tag{3.21}$$

and

$$\begin{aligned}
g(c) &= g(b) + g'(b)(c-b) + \frac{g''(\xi_2)}{2!}(c-b)^2 \\
&= \int_a^b f(t) dt + f(b)(c-b) + \frac{f'(\xi_2)}{2!}(c-b)^2 \\
&= \int_a^b f(t) dt + \frac{f'(\xi_2)}{2}(c-b)^2.
\end{aligned} \tag{3.22}$$

where $\xi_1 \in (a, c)$ and $\xi_2 \in (c, b)$. Subtracting between (3.21) and (3.22) yields

$$\begin{aligned} \left| \int_a^b f(t) dt \right| &= \left| \frac{f'(\xi_1)}{2}(c-a)^2 - \frac{f'(\xi_2)}{2}(c-b)^2 \right| \\ &\leq \left| \frac{f'(\xi_1)}{2}(c-a)^2 \right| + \left| \frac{f'(\xi_2)}{2}(c-b)^2 \right| \\ &= \frac{|f'(\xi_1)|}{2}(c-a)^2 + \frac{|f'(\xi_2)|}{2}(c-b)^2 \\ &\leq \frac{M}{2} [(c-a)^2 + (c-b)^2]. \end{aligned}$$

It is clear that the function $p(c) = (c-a)^2 + (c-b)^2$ has a minimum $\frac{(b-a)^2}{2}$ at the point $c = \frac{a+b}{2}$. Theorem 3.7 is proved. \square

3.3.10. *The fifth proof of Theorem 3.7.* Using properties of definite integral and applying Lemma 2.2 to the integrands yield

$$\begin{aligned} \left| \int_a^b f(x) dx \right| &= \left| \int_a^c f(x) dx + \int_c^b f(x) dx \right| \\ &\leq \left| \int_a^c [f(x) - f(a)] dx \right| + \left| \int_c^b [f(x) - f(b)] dx \right| \\ &= \left| \int_a^c (x-a)f'(\eta_1) dx \right| + \left| \int_c^b (x-b)f'(\eta_2) dx \right| \\ &\leq \int_a^c (x-a)|f'(\eta_1)| dx + \int_c^b (b-x)|f'(\eta_2)| dx \\ &\leq M \left[\int_a^c (x-a) dx + \int_c^b (b-x) dx \right] \\ &= M \left[c^2 - (a+b)c + \frac{a^2 + b^2}{2} \right], \end{aligned}$$

where $\eta_1 \in (a, x)$ and $\eta_2 \in (x, b)$ in the third and fourth lines are dependent of x and $c \in [a, b]$.

Since the function $h(x)$ defined by (3.19) attains its minimum $\frac{(b-a)^2}{4}$ at $x = \frac{a+b}{2}$, Theorem 3.7 follows. \square

3.4. Qi's refinement of Pólya type integral inequalities. By using Lemma 2.2, a refinement of Pólya type integral inequalities were obtained in [39].

Theorem 3.8. *Let $f(x)$ be continuous on $[a, b]$ and differentiable in (a, b) . Suppose that $f(a) = f(b) = 0$, and that $m \leq f'(x) \leq M$ in (a, b) . If $f(x)$ is not identically zero, then $m < 0 < M$ and*

$$\left| \int_a^b f(x) dx \right| \leq -\frac{(b-a)^2}{2} \frac{mM}{M-m}. \quad (3.23)$$

Proof. That $m < 0 < M$ is an immediate consequence of Lemma 2.2.

The idea now is to apply Lemma 2.2 again in order to estimate the integral. Let c be a parameter satisfying $a < c < b$, and write

$$\begin{aligned} \int_a^b f(x) dx &= \int_a^c [f(x) - f(a)] dx + \int_c^b [f(x) - f(b)] dx \\ &= \int_a^c (x-a)f'(\theta_1) dx + \int_c^b (x-b)f'(\theta_2) dx, \end{aligned}$$

where $a < \theta_1 < c < \theta_2 < b$. From $f'(\theta_1) \leq M$ and $f'(\theta_2) \geq m$, it now follows that

$$\begin{aligned} \int_a^b f(x) \, dx &\leq M \int_a^c (x-a) \, dx + m \int_c^b (x-b) \, dx \\ &= \frac{M-m}{2}c^2 + (bm - aM)c + \frac{a^2M - b^2m}{2} \end{aligned}$$

and the upper bound is merely a quadratic expression on the parameter c .

Moreover, it is easy to check that this quadratic has the minimum value

$$-\frac{(b-a)^2}{2} \frac{mM}{M-m}$$

when $c = \frac{aM-bm}{M-m}$, and this value of c does satisfy $a < c < b$. Therefore

$$\int_a^b f(x) \, dx \leq -\frac{(b-a)^2}{2} \frac{mM}{M-m}. \quad (3.24)$$

Similarly, we have

$$\begin{aligned} \int_a^b f(x) \, dx &\geq m \int_a^c (x-a) \, dx + M \int_c^b (x-b) \, dx \\ &= \frac{m-M}{2}c^2 + (bM - am)c + \frac{a^2m - b^2M}{2}, \end{aligned} \quad (3.25)$$

and, on maximising this with respect to c , we find that

$$\int_a^b f(x) \, dx \geq \frac{(b-a)^2}{2} \frac{mM}{M-m}. \quad (3.26)$$

The required result (3.23) follows from (3.24) and (3.26). \square

3.5. Two equivalences. Now we establish two equivalences between Pólya type integral inequalities. The idea comes from [26].

Theorem 3.9. *The inequality (3.12) in Theorem 3.7 is equivalent to the statement that if $g(x)$ is differentiable and not identically constant on $[0, 1]$ with $g(0) = g(1) = 0$, then*

$$\left| \int_0^1 g(x) \, dx \right| \leq \frac{1}{4} \sup_{x \in [0,1]} |g'(x)| \quad (3.27)$$

and the constant $\frac{1}{4}$ in (3.27) is the best possible.

Proof. If taking $a = 0$ and $b = 1$ in Theorem 3.7, then the inequality (3.12) is reduced to (3.27).

Conversely, let $g(x) = f(x(b-a) + a)$ for $x \in [0, 1]$ in (3.27), then

$$\begin{aligned} g(0) &= f(a) = 0, & g(1) &= f(b) = 0, \\ g'(x) &= (b-a)f'(x(b-a) + a), \\ |g'(x)| &= (b-a)|f'(x(b-a) + a)|, \\ \left| \int_0^1 f(x(b-a) + a) \, dx \right| &\leq \frac{(b-a)}{4} \sup_{x \in [0,1]} |f'(x(b-a) + a)|, \end{aligned}$$

which is reduced, by transform of variable, to

$$\left| \int_a^b f(t) \frac{dt}{b-a} \right| \leq \frac{(b-a)}{4} \max_{t \in [a,b]} |f'(t)|$$

which means the inequality (3.12). \square

Theorem 3.10. *The inequality (3.23) in Theorem 3.8 is equivalent to the statement that if $g(x)$ is continuous on $[0, 1]$ and differentiable in $(0, 1)$ satisfying that $g(0) = g(1) = 0$, $m \leq g'(x) \leq M$ in $(0, 1)$, and that $g(x)$ is not identically zero, then $m < 0 < M$ and*

$$\left| \int_0^1 g(x) dx \right| \leq -\frac{mM}{2(M-m)}. \quad (3.28)$$

Proof. This follows from the same arguments as in the proof of Theorem 3.9. \square

The inequality (3.27) may be called the normalized integral inequality of Pólya type. Similarly, the inequality (3.28) may be called the normalized integral inequality of Qi type.

3.6. Remarks. We are now give some remarks.

Remark 3.1. If replacing the condition $f(a) = f(b) = 0$ by $f(a) = f(b) = A$ in Theorem 3.8, then the inequality (3.23) becomes

$$\left| \frac{1}{b-a} \int_a^b f(x) dx - A \right| \leq -\frac{b-a}{2} \frac{mM}{M-m}. \quad (3.29)$$

Remark 3.2. Let

$$D = \{x = (x_1, x_2, \dots, x_n) \in \mathbb{R}^n : |x| \leq r, n \in \mathbb{N}\} \quad (3.30)$$

and $f : D \rightarrow \mathbb{R}$. We conjecture that if all partial derivatives of f exist and the value of f vanishes on the boundary of D , then there exists at least one point $\eta \in D$ such that

$$\frac{n!(n+1)}{2^{\lceil n/2 \rceil} \pi^{\lfloor n/2 \rfloor} r^{n+1}} \int_D f(x) dx < \sqrt{\sum_{k=1}^n \left[\frac{\partial f(\eta)}{\partial x^k} \right]^2}, \quad (3.31)$$

where $\lceil \frac{n}{2} \rceil$ and $\lfloor \frac{n}{2} \rfloor$ denote respectively the least and largest integers than $\frac{n}{2}$.

Remark 3.3. It is easy to see that the inequality (3.8) can be rewritten as

$$|f''(\xi)| \geq \frac{4}{(b-a)^2} \left| \int_a^b f'(t) dt \right|. \quad (3.32)$$

So, Theorem 3.3 is a variant of Theorem 3.1.

Remark 3.4. Under the same conditions as in Theorem 3.7, if using the mean value theorems for integral and for derivative in sequence, then a weaker integral inequality than the inequality (3.12) can be obtained as follows:

$$\begin{aligned} \left| \int_a^b f(x) dx \right| &= |(b-a)f(\theta)| \\ &= \frac{(b-a)[f(\theta) - f(a)] + [f(\theta) - f(b)]}{2} \\ &= \frac{(b-a)[(\theta-a)f'(\eta_1) + (\theta-b)f'(\eta_2)]}{2} \\ &\leq \frac{(b-a)[(\theta-a) + (b-\theta)]M}{2} \\ &= \frac{(b-a)^2 M}{2}, \end{aligned}$$

where $\theta \in [a, b]$, $\eta_1 \in (a, \theta)$, and $\eta_2 \in (\theta, b)$.

4. IYENGAR-MAHAJANI'S INTEGRAL INEQUALITY AND ITS PROOFS

The first object of this section is to give a generalization of Pólya type integral inequalities stated in Section 3. This generalization, called Iyengar-Mahajani's integral inequality, are attributed to K. S. K. Iyengar [19] and G. S. Mahajani [28]. The second object is to present analytic proofs of Iyengar-Mahajani's integral inequality.

4.1. Iyengar-Mahajani's integral inequality. In [19, 28], motivated by [36, Problem 121], K. S. K. Iyengar and G. S. Mahajani, by means of geometrical considerations, respectively proposed proving the following generalization of Pólya type integral inequalities.

Theorem 4.1. *Let $f(x)$ be continuous and not identically a constant on $[a, b]$. If M is the upper bound of $|f'(x)|$ in (a, b) , then*

$$\left| \int_a^b f(t) dt - \frac{1}{2}(b-a)[f(a) + f(b)] \right| < \frac{M(b-a)^2}{4} - \frac{1}{4M}[f(b) - f(a)]^2. \quad (4.1)$$

The inequality (4.1) is sharp in the sense that it can not be improved.

Remark 4.1. The inequality (4.1) is called Iyengar-Mahajani's integral inequality, since it was first proved in [19, 28]. See also [31, pp. 297–298, 3.7.24] and [25, pp. 558–559].

Remark 4.2. Taking $f(a) = f(b) = 0$ in (4.1) yields inequalities (3.7) and (3.11) readily. So Theorem 4.1 is a generalization of Pólya type integral inequalities.

4.2. Geometric proofs of Iyengar-Mahajani's integral inequality. The following two geometric proofs are due to Iyengar [19] and Mahajani [28] respectively.

4.2.1. Iyengar's geometric proof. It is clear that

$$\int_a^b f(t) dt - \frac{1}{2}(b-a)[f(a) + f(b)] = \int_a^b \left[f(t) - \frac{f(a) + f(b)}{2} \right] dt.$$

Let

$$\phi(t) = f(t) - \frac{f(a) + f(b)}{2}.$$

Then $\phi(a) + \phi(b) = 0$. Let

$$\alpha = \phi(a) = -\frac{f(b) - f(a)}{2}.$$

Then, as shown by Figure 4.1, the curve $y = \phi(t)$ lies below the lines

$$y = \alpha + M(t - a), \quad (\text{Line } BC)$$

$$y = -\alpha - M(t - b), \quad (\text{Line } CE)$$

in other words, it lies below the polygonal line $BCDE$. Similarly it lies above the polygonal line $BD'C'E$. Hence

$$\begin{aligned} \int_a^b \phi(t) dt &\leq \text{area under } BCDE \\ &= \frac{1}{2}(CP + AB)AP + \frac{1}{2}(CP - EF)PF. \end{aligned}$$

An easy calculation gives

$$\begin{aligned} CP &= \frac{1}{2}M(b-a), & EF &= AB = \alpha, \\ AP &= \frac{1}{2}(b-a) - \frac{\alpha}{M}, & PF &= \frac{1}{2}(b-a) + \frac{\alpha}{M}. \end{aligned}$$

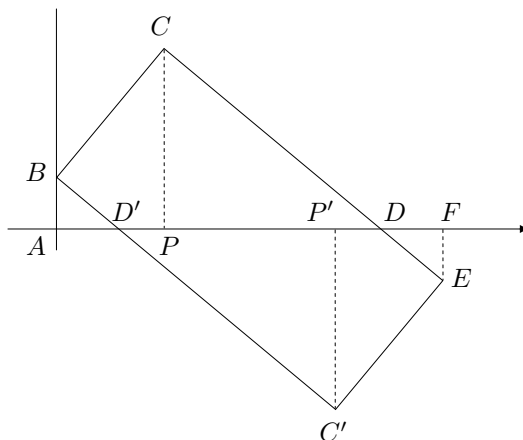

FIGURE 4.1.

Therefore,

$$\begin{aligned} \int_a^b \phi(t) dt &\leq \frac{1}{2} \left\{ \left[\frac{1}{2}M(b-a) + \alpha \right] \left(\frac{b-a}{2} - \frac{\alpha}{M} \right) \right. \\ &\quad \left. + \left[\frac{1}{2}(b-a)M - \alpha \right] \left(\frac{b-a}{2} + \frac{\alpha}{M} \right) \right\} \\ &= \frac{M(b-a)^2}{4} - \frac{\alpha^2}{M} \\ &= \frac{M(b-a)^2}{4} - \frac{1}{4M} [f(b) - f(a)]^2. \end{aligned}$$

Similarly, considering the curve $BD'C'E$ gives

$$\int_a^b \phi(t) dt \geq \frac{\alpha^2}{M} - \frac{M(b-a)^2}{4}.$$

Hence

$$\begin{aligned} \left| \int_a^b \phi(t) dt \right| &= \left| \int_a^b f(t) dt - \frac{1}{2}(b-a)[f(a) + f(b)] \right| \\ &\leq \frac{M(b-a)^2}{4} - \frac{1}{4M} [f(b) - f(a)]^2. \end{aligned}$$

It is quite clear that equality can only occur when $\phi(t)$ coincides completely with $BCDE$ or $BD'C'E$, which is however not possible since $\phi'(t)$ exists at the points P and P' . Hence the inequality (4.1) is proved.

Since we can approximate to $BCDE$ as closely as we like by a curve through B and E , it is obvious that the inequality (4.1) cannot be improved. \square

4.2.2. *Mahajani's geometric proof.* As shown by Figure 4.2, the lines KA and KB are equally inclined to the x -axis, and $\tan \alpha = M$, $\alpha = \angle KAF$, so that KTB is isosceles, KT and KB being equally inclined to TB . Figure 4.2 shows that trapezium $ARSB = \frac{b-a}{2}[f(a) + f(b)]$, so the left term in (4.1) equals identically the area between the curve AB and the chord AB and this is less than the area of the triangle KAB .

Now,

$$\begin{aligned} \triangle KAB &= \triangle AFT - \triangle AFB - \triangle KTB \\ &= \frac{1}{2}AF \cdot FT - \frac{1}{2}AF \cdot FB - \frac{1}{2}TB \cdot \frac{1}{2}TB \cdot \tan \angle KTB \end{aligned}$$

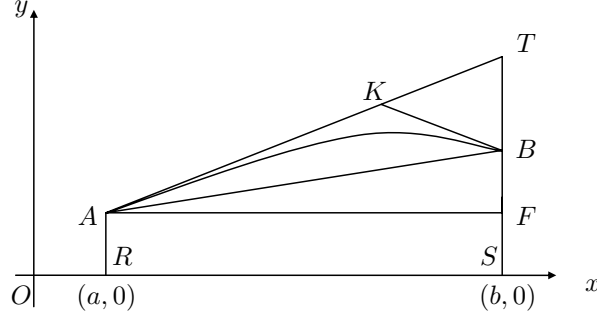

FIGURE 4.2.

$$\begin{aligned}
&= \frac{1}{2}(b-a)^2 \tan \alpha - \frac{b-a}{2}[f(b) - f(a)] - \frac{TB^2}{4} \cot \alpha \\
&= \frac{(b-a)^2 \tan \alpha}{2} - \frac{b-a}{2}[f(b) - f(a)] \\
&\quad - \frac{1}{4}\{(b-a) \tan \alpha - [f(b) - f(a)]\}^2 \cot \alpha \\
&= \frac{(b-a)^2}{4} \tan \alpha - \frac{[f(b) - f(a)]^2}{4} \cot \alpha \\
&= \frac{(b-a)^2}{4} M - \frac{[f(b) - f(a)]^2}{4M}.
\end{aligned}$$

The proof of Theorem 4.1 is complete. \square

4.3. Analytic proofs of Iyengar-Mahajani's integral inequality. In this section, Iyengar-Mahajani's integral inequality (4.1) with equality will be proved analytically by using Lemma 2.3 and the method used in Section 3.3.6 respectively.

Theorem 4.2. *Let $f(x)$ be continuous and not identically a constant on $[a, b]$ and differentiable in (a, b) such that $M = \sup_{x \in (a, b)} |f'(x)|$. Then*

$$\left| \frac{1}{b-a} \int_a^b f(x) dx - \frac{f(a) + f(b)}{2} \right| \leq \frac{b-a}{4M} [M^2 - S_0^2(a, b)], \quad (4.2)$$

where

$$S_0(a, b) = \frac{f(b) - f(a)}{b-a}. \quad (4.3)$$

The inequality (4.2) is sharp in the sense that it can not be improved.

Remark 4.3. If taking $f(a) = f(b) = 0$, then the inequality (4.2) is reduced to (3.9) and (3.12). So Theorem 4.1 is a generalization of Pólya type integral inequalities.

Remark 4.4. The inequality (4.2) is a rearrangement of the inequality (4.1) and gives lower and upper bounds of the difference between the integral mean of $f(x)$ on $[a, b]$ and the arithmetic mean of $f(a)$ and $f(b)$.

4.3.1. *The first analytic proof of the inequality (4.2).* Define

$$\psi(x) = \int_a^x f(t) dt$$

for $x \in [a, b]$. Then $\psi(a) = 0$, $\psi(b) = \int_a^b f(t) dt$, and $\psi(x)$ is differentiable on $[a, b]$ and two times differentiable in (a, b) . By Lemma 2.3, for any $c \in (a, b)$, we have

$$\begin{aligned}\psi(c) &= \psi(a) + \psi'(a)(c-a) + \frac{\psi''(\eta_1)}{2!}(c-a)^2 \\ &= f(a)(c-a) + \frac{f'(\eta_1)}{2}(c-a)^2,\end{aligned}\tag{4.4}$$

$$\begin{aligned}\psi(c) &= \psi(b) + \psi'(b)(c-b) + \frac{\psi''(\eta_2)}{2!}(c-b)^2 \\ &= \int_a^b f(t) dt + f(b)(c-b) + \frac{f'(\eta_2)}{2}(c-b)^2.\end{aligned}\tag{4.5}$$

Subtracting between (4.4) and (4.5) and simplifying results in

$$\begin{aligned}& \left| \int_a^b f(t) dt - [bf(b) - af(a)] + [f(b) - f(a)]c \right| \\ &= \left| \frac{f'(\eta_1)}{2}(c-a)^2 - \frac{f'(\eta_2)}{2}(c-b)^2 \right| \\ &\leq \left| \frac{f'(\eta_1)}{2}(c-a)^2 \right| + \left| \frac{f'(\eta_2)}{2}(c-b)^2 \right| \\ &\leq \frac{M}{2} [(c-a)^2 + (c-b)^2],\end{aligned}$$

where $\eta_1 \in (a, c)$ and $\eta_2 \in (c, b)$, which is equivalent to

$$\begin{aligned}-\frac{M}{2} [(c-a)^2 + (c-b)^2] - [f(b) - f(a)]c &\leq \int_a^b f(t) dt - [bf(b) - af(a)] \\ &\leq \frac{M}{2} [(c-a)^2 + (c-b)^2] - [f(b) - f(a)]c.\end{aligned}$$

It is easy to see that the function

$$\frac{M}{2} [(c-a)^2 + (c-b)^2] - [f(b) - f(a)]c$$

takes its minimum

$$\frac{[f(b) - f(a)]^2}{4M} - \frac{(b-a)^2 M}{4} + \frac{a+b}{2} [f(b) - f(a)]$$

at the point

$$c = \frac{f(b) - f(a)}{2M} + \frac{a+b}{2} \in [a, b]$$

and the function

$$-\frac{M}{2} [(c-a)^2 + (c-b)^2] - [f(b) - f(a)]c$$

attains its maximum

$$\frac{[f(b) - f(a)]^2}{4M} - \frac{(b-a)^2 M}{4} - \frac{a+b}{2} [f(b) - f(a)]$$

at the point

$$c = \frac{f(a) - f(b)}{2M} + \frac{a+b}{2} \in [a, b].$$

Consequently,

$$\begin{aligned}\frac{[f(b) - f(a)]^2}{4M} - \frac{(b-a)^2 M}{4} - \frac{a+b}{2} [f(b) - f(a)] \\ \leq \int_a^b f(t) dt - [bf(b) - af(a)]\end{aligned}$$

$$\leq \frac{(b-a)^2 M}{4} - \frac{[f(b) - f(a)]^2}{4M} - \frac{a+b}{2} [f(b) - f(a)],$$

which is equivalent to the inequality (4.2). \square

4.3.2. *The second analytic proof of the inequality (4.2).* This proof is excerpted from [45, p. 163]. Similar to the first proof of Theorem 3.7 in Section 3.3.6 on pages 13–13, Theorem 4.2 can also be verified by utilizing the following inequalities

$$f(x) \leq L(x) = \begin{cases} f(a) + M(x-a), & a \leq x \leq c, \\ f(b) + M(b-x), & c \leq x \leq b, \end{cases}$$

and

$$f(x) \geq \ell(x) = \begin{cases} f(a) - M(x-a), & a \leq x \leq d, \\ f(b) - M(b-x), & d \leq x \leq b \end{cases}$$

to estimate the integral $\int_a^b f(x) dx$. \square

5. REFINEMENTS OF IYENGAR-MAHAJANI'S INTEGRAL INEQUALITY

Iyengar-Mahajani's integral inequality (4.1) was refined in [1, 5, 26, 39] respectively and independently.

5.1. Agarwal-Cerone-Dragomir's integral inequality. Employing Hayashi's integral inequality (2.5), Iyengar-Mahajani's integral inequality (4.1) was refined by R. P. Agarwal and S. S. Dragomir in [1] and by P. Cerone and S. S. Dragomir in [5] respectively.

Their result can be quoted as follows.

Theorem 5.1 ([1, Theorem 2]). *Let f be a differentiable function on $[a, b]$ with*

$$M = \max_{x \in [a, b]} f'(x), \quad m = \min_{x \in [a, b]} f'(x) \quad (5.1)$$

and $M > m$. If f' is integrable on $[a, b]$, then

$$\begin{aligned} & \left| \frac{1}{b-a} \int_a^b f(x) dx - \frac{f(a) + f(b)}{2} \right| \\ & \leq \frac{[f(b) - f(a) - m(b-a)][M(b-a) - f(b) + f(a)]}{2(M-m)(b-a)} \end{aligned} \quad (5.2)$$

$$\leq \frac{(M-m)(b-a)}{8}. \quad (5.3)$$

5.1.1. *Agarwal-Dragomir's proof.* Let $h(x) = a-x$ and $g(x) = f'(x) - m$, and apply Hayashi's integral inequality (2.5), to obtain

$$(M-m) \int_{b-\lambda}^b (a-x) dx \leq Q \leq (M-m) \int_a^{a+\lambda} (a-x) dx, \quad (5.4)$$

where

$$Q = \int_a^b (a-x)[f'(x) - m] dx$$

and

$$\lambda = \frac{1}{M-m} \int_a^b [f'(x) - m] dx = \frac{f(b) - f(a) - m(b-a)}{M-m}.$$

Since

$$\int_{b-\lambda}^b (a-x) dx = \frac{1}{2} [(b-a-\lambda)^2 - (b-a)^2]$$

and

$$\int_a^{a+\lambda} (a-x) dx = -\frac{\lambda^2}{2},$$

the inequality (5.4) is the same as

$$\ell_1 \triangleq (M - m) \left[\frac{(b - a - \lambda)^2 - (b - a)^2}{2} \right] \leq Q \leq (M - m) \left[-\frac{\lambda^2}{2} \right] \triangleq \ell_2. \quad (5.5)$$

Next, since

$$\begin{aligned} \frac{\ell_1 + \ell_2}{2} &= \frac{M - m}{2} \left[-\frac{\lambda^2}{2} + \frac{(b - a - \lambda)^2}{2} - \frac{(b - a)^2}{2} \right] \\ &= \frac{(M - m)[- \lambda(b - a)]}{2} \\ &= \frac{m(b - a)^2}{2} - \frac{(b - a)[f(b) - f(a)]}{2} \end{aligned}$$

and

$$Q = \int_a^b f(x) dx - (b - a)f(b) + \frac{m(b - a)^2}{2},$$

it follows that

$$\left| Q - \frac{\ell_1 + \ell_2}{2} \right| = \left| \int_a^b f(x) dx - (b - a) \frac{f(a) + f(b)}{2} \right|. \quad (5.6)$$

The inequality (5.5) implies

$$\begin{aligned} \left| Q - \frac{\ell_1 + \ell_2}{2} \right| &\leq \frac{\ell_2 - \ell_1}{2} \\ &= \frac{M - m}{2} \left[-\frac{\lambda^2}{2} + \frac{(b - a)^2}{2} - \frac{(b - a - \lambda)^2}{2} \right] \\ &= \frac{M - m}{2} [-\lambda^2 + (b - a)\lambda] \\ &= \frac{[f(b) - f(a) - m(b - a)][M(b - a) - f(b) + f(a)]}{2(M - m)}. \end{aligned} \quad (5.7)$$

Now on combining (5.6) and (5.7) we immediately obtain the inequality (5.2).

To prove (5.3), define $p(t) = -t^2 + (b - a)t$. It is clear that

$$p(t) \leq p\left(\frac{b - a}{2}\right) = \frac{(b - a)^2}{4} \quad (5.8)$$

for all $t \in \mathbb{R}$.

We choose

$$t = \lambda = \frac{f(b) - f(a) - m(b - a)}{M - m},$$

so that

$$\frac{M - m}{2} p(\lambda) = \frac{[f(b) - f(a) - m(b - a)][M(b - a) - f(b) + f(a)]}{2(M - m)}. \quad (5.9)$$

From (5.8) and (5.9), we have

$$\frac{M - m}{2} p(\lambda) \leq \frac{(M - m)(b - a)^2}{8},$$

which in view of (5.2) proves the required the inequality (5.3). \square

5.1.2. *Cerone-Dragomir's proof.* Let $h(x) = \theta - x$ for $\theta \in [a, b]$ and $g(x) = f'(x) - m$. Then, from Hayashi's integral inequality (2.5), we have

$$L \leq I \leq U, \quad (5.10)$$

where

$$I = \int_a^b (\theta - x)[f'(x) - m] dx,$$

$$\lambda = \frac{1}{M - m} \int_a^b [f'(x) - m] dx,$$

$$L = (M - m) \int_{b-\lambda}^b (\theta - x) dx,$$

$$U = (M - m) \int_a^{a+\lambda} (\theta - x) dx.$$

It is now a straightforward matter to evaluate and simplify the above expansions to give

$$I = \int_a^b f(u) du - \left[m(b-a) \left(\theta - \frac{b+a}{2} \right) + (b-\theta)f(b) + (\theta-a)f(a) \right], \quad (5.11)$$

$$\lambda = \frac{1}{M-m} [f(b) - f(a) - m(b-a)] = \frac{b-a}{M-m} (S - m), \quad (5.12)$$

$$L = \frac{(M-m)}{2} \lambda [\lambda + 2(\theta - b)], \quad (5.13)$$

$$U = \frac{(M-m)}{2} \lambda [2(\theta - a) - \lambda]. \quad (5.14)$$

In addition, it may be noticed from (5.10), that

$$\left| I - \frac{U+L}{2} \right| \leq \frac{U-L}{2}, \quad (5.15)$$

where, upon using (5.13) and (5.14),

$$\frac{U+L}{2} = (M-m)\lambda \left(\theta - \frac{b+a}{2} \right) \quad (5.16)$$

and

$$\frac{U-L}{2} = \frac{(M-m)}{2} \lambda (b-a-\lambda). \quad (5.17)$$

Equation (5.15) is then, (5.2) upon using (5.11), (5.12), (5.16) and (5.17) together with some routine simplification.

Now, for the inequality (5.3). Consider the right-hand side of (5.3). Completing the square gives

$$\begin{aligned} & \frac{(b-a)^2}{2(M-m)} (S-m)(M-S) \\ &= \frac{2}{M-m} \left(\frac{b-a}{2} \right)^2 \left[\left(\frac{M-m}{2} \right)^2 - \left(S - \frac{M+m}{2} \right)^2 \right] \end{aligned} \quad (5.18)$$

and (5.3) is readily determined by neglecting the negative term. \square

5.2. Qi's integral inequality. Using Rolle's mean value theorem, i.e., Lemma 2.1, Iyengar-Mahajani's integral inequality (4.1) was earlier refined by Qi in [39].

By virtue of the same techniques as that used in deduction of Lemma 2.2 itself from Lemma 2.1, Iyengar-Mahajani's integral inequality (4.1) was refined while Theorem 3.8 was generalized by removing the hypothesis $f(a) = f(b) = 0$ in [39].

Theorem 5.2 ([39, Proposition 2]). *Let $f(x)$ be continuous on $[a, b]$ and differentiable in (a, b) . Suppose that $f(x)$ is not identically a constant, and that $m \leq f'(x) \leq M$ in (a, b) . Then*

$$\begin{aligned} & \left| \frac{1}{b-a} \int_a^b f(x) \, dx - \frac{f(a) + f(b)}{2} \right| \\ & \leq \frac{[f(b) - f(a) - m(b-a)][M(b-a) - f(b) + f(a)]}{2(M-m)(b-a)} \\ & = -\frac{[M - S_0(a, b)][m - S_0(a, b)]}{2(M-m)}(b-a), \end{aligned} \tag{5.19}$$

where

$$S_0(a, b) = \frac{f(b) - f(a)}{b-a}. \tag{5.20}$$

Proof. For $a \leq x \leq b$ we set

$$\psi(x) = [f(x) - f(a)](b-a) - [f(b) - f(a)](x-a),$$

so that $\psi(a) = \psi(b) = 0$. We also have $\psi'(x) = (b-a)f'(x) - f(b) + f(a)$, and hence

$$(b-a)m - f(b) + f(a) \leq \psi'(x) \leq (b-a)M - f(b) + f(a).$$

The required result (5.19) now follows from Theorem 3.8 applied to $\psi(x)$, noting that

$$\int_a^b \psi(x) \, dx = (b-a) \int_a^b f(x) \, dx - \frac{(b-a)^2[f(a) + f(b)]}{2}.$$

The proof of Theorem 5.2 is completed. \square

For convenience, the inequalities (5.2) and (5.19) are called Qi-Agarwal-Cerone-Dragomir's integral inequality.

5.3. An equivalent relation. In [26], Z. Liu and Y.-X. Shi proved Qi-Agarwal-Cerone-Dragomir's integral inequality (5.2) and (5.19). A minor modification of their result implies an equivalent relation between Iyengar-Mahajani's and Qi-Agarwal-Cerone-Dragomir's integral inequality.

Theorem 5.3. *Theorems 3.8, 4.1, and 5.2 are equivalent to each other. In other words, the inequality (3.23), Iyengar-Mahajani's integral inequality (4.1), and Qi-Agarwal-Cerone-Dragomir's integral inequality (5.19) are equivalent to one another.*

Proof. In view of proofs of Theorems 3.8 and 5.2, as the equivalent relation between Rolle's and Lagrange's mean value theorems, the equivalent relation between Theorems 3.8 and 5.2 is obvious.

Taking $M = -m$ in (5.19) leads readily to the inequality (4.1).

Conversely, the condition $m \leq f'(x) \leq M$ is equivalent to

$$\left| f'(x) - \frac{m+M}{2} \right| \leq \frac{M-m}{2}.$$

Let

$$F(x) = f(x) - \frac{M+m}{2}x$$

on $[a, b]$. Then $|f'(x)| \leq \frac{M-m}{2}$ and $M-m > 0$. Utilizing Theorem 4.1 reveals

$$\left| \int_a^b F(x) \, dx - \frac{1}{2}(b-a)[F(a) + F(b)] \right| \leq \frac{(M-m)(b-a)^2}{8} - \frac{[F(b) - F(a)]^2}{2(M-m)}.$$

A direct computation shows

$$\begin{aligned}
& \int_a^b F(x) \, dx - \frac{1}{2}(b-a)[F(a) + F(b)] \\
&= \int_a^b \left[f(x) - \frac{m+M}{2}x \right] \, dx - \frac{1}{2}(b-a) \left[f(a) + f(b) - \frac{m+M}{2}(a+b) \right] \\
&= \int_a^b f(x) \, dx - \frac{1}{2}(b-a)[f(a) + f(b)]
\end{aligned}$$

and

$$\begin{aligned}
& \frac{(M-m)(b-a)^2}{8} - \frac{[F(b) - F(a)]^2}{2(M-m)} \\
&= \frac{\{(M-m)(b-a) + 2[F(b) - F(a)]\} \{(M-m)(b-a) - 2[F(b) - F(a)]\}}{8(M-m)} \\
&= \frac{[f(b) - f(a) - m(b-a)][M(b-a) - f(b) + f(a)]}{2(M-m)(b-a)}.
\end{aligned}$$

The proof of Theorem 5.3 is complete. \square

5.4. Remarks.

Remark 5.1. It is well-known that an integrable function is bounded. Conversely, a bounded function may be not integrable. Therefore, the hypotheses in Theorem 5.1 are stronger than those in Theorem 5.2.

Remark 5.2. By using integration-by-part, under the conditions of Theorems 4.1 and 4.2, it may be remarked that

$$\begin{aligned}
& \left| \int_a^b f(t) \, dt - \frac{1}{2}(b-a)\{f(a) + f(b)\} \right| = \left| \int_a^b \left(\frac{a+b}{2} - x \right) f'(x) \, dx \right| \\
& \leq \int_a^b \left| \frac{a+b}{2} - x \right| |f'(x)| \, dx \leq M \int_a^b \left| \frac{a+b}{2} - x \right| \, dx = \frac{M(b-a)^2}{4}, \quad (5.21)
\end{aligned}$$

which is obviously a much weaker inequality than Iyengar-Mahajani's integral inequality (4.1) or (4.2).

Remark 5.3. If letting $M = -m$, then (5.3) is reduced to (5.21).

Remark 5.4. In the original papers [19, 28], the condition “not identically constant” and the continuity of the integrand $f(x)$ at the two end points of the closed interval $[a, b]$ in Theorems 4.1 and 4.2 were pretermitted.

Remark 5.5. By placing $m = -M$ in the inequality (5.19) then Iyengar-Mahajani's integral inequality (4.1) and its equivalent forms (4.2) is recovered.

Remark 5.6. Inequalities (5.2) and (5.19) can also be rewritten as

$$\begin{aligned}
& \left| \frac{1}{b-a} \int_a^b f(x) \, dx - \frac{f(a) + f(b)}{2} \right| \\
& \leq \frac{(M-m)(b-a)}{2} \left[\frac{1}{4} - \frac{\left(\frac{f(b)-f(a)}{b-a} - \frac{M+m}{2} \right)^2}{(M-m)^2} \right]
\end{aligned}$$

or

$$\begin{aligned}
& \frac{mM(b-a)^2 - 2(b-a)[mf(b) - Mf(a)] + [f(b) - f(a)]^2}{2(M-m)} \leq \int_a^b f(x) \, dx \\
& \leq -\frac{mM(b-a)^2 - 2(b-a)[Mf(b) - mf(a)] + [f(b) - f(a)]^2}{2(M-m)}.
\end{aligned}$$

Remark 5.7. Now considering the right-hand side of (5.2) and completing the square give

$$\frac{(S-m)(M-S)}{2(M-m)} = \frac{b-a}{2(M-m)} \left[\left(\frac{M-m}{2} \right)^2 - \left(S - \frac{M+m}{2} \right)^2 \right]$$

and (5.3) is readily determined by neglecting the negative term.

Remark 5.8. It should also be noted that if either both m and M are positive or both negative, then the bound obtained here is tighter than that of Iyengar as given by (4.1).

Remark 5.9. Till now we can see that, comparing with Agarwal-Dragomir's proof in [1], Qi's proof in [39] and Cerone-Dragomir's proof in [5] simplify the working and, it is argued, are more enlightening. In other words, among proofs in [1, 5, 26, 39], Qi's proof provided in [39] is simplest and most insightful.

6. APPLICATIONS OF QI-AGARWAL-CERONE-DRAGOMIR'S INEQUALITY

Qi-Agarwal-Cerone-Dragomir's inequality in Theorem 5.1 or 5.2 has been applied to the theory of convex functions, means, and the complete elliptic integrals.

6.1. An applications to convex functions. For a convex function $f : [a, b] \rightarrow \mathbb{R}$, the double inequality

$$f\left(\frac{a+b}{2}\right) \leq \frac{1}{b-a} \int_a^b f(x) dx \leq \frac{f(a)+f(b)}{2} \quad (6.1)$$

is well-known in literature as Hermite-Hadamard's integral inequality. For more information, please refer to [9, 34, 40] and references therein.

If applying f in Agarwal-Cerone-Dragomir's integral inequality in Theorem 5.1 to a differentiable convex function, we may deduce the following theorem which is very important in applications in the subsequent subsection.

Theorem 6.1 ([1, Corollary 4]). *Let f be a differentiable convex function on $[a, b]$ such that $f'(a) \neq f'(b)$. Then we have*

$$\begin{aligned} 0 &\leq \frac{f(a)+f(b)}{2} - \frac{1}{b-a} \int_a^b f(x) dx \\ &\leq \frac{[f(b)-f(a)-f'(a)(b-a)][f'(b)(b-a)-f(b)+f(a)]}{2(b-a)[f'(b)-f'(a)]} \\ &\leq \frac{(b-a)[f'(b)-f'(a)]}{8}. \end{aligned} \quad (6.2)$$

Proof. This follows from Theorem 5.1 and the observation that we can choose $m = f'(a)$ and $M = f'(b)$. \square

6.2. Applications to special means. For positive numbers a and b we recall the means

$$\begin{aligned} A(a, b) &= \frac{a+b}{2}, & G(a, b) &= \sqrt{ab}, \\ H(a, b) &= \frac{2}{1/a+1/b}, & L(a, b) &= \frac{a-b}{\ln a - \ln b}, \\ I(a, b) &= \frac{1}{e} \left(\frac{b^b}{a^a} \right)^{1/(b-a)}, & L_p(a, b) &= \left[\frac{b^{p+1} - a^{p+1}}{(p+1)(b-a)} \right]^{1/p}. \end{aligned}$$

These means are called in literature the arithmetic, geometric, harmonic, logarithmic, identric or exponential, and generalized logarithmic means. For more detailed information on these means, please refer to [3, 13, 16] and plenty of references therein.

Now we use Theorem 6.1 to find the following facts for the above means.

Theorem 6.2 ([1, Proposition 1]). *Let $p \geq 1$ and $0 \leq a \leq b$. Then*

$$\begin{aligned} 0 &\leq A(a^p, b^p) - L_p^p(a, b) \\ &\leq \frac{p}{2(p-1)} \frac{[L_{p-1}^{p-1}(a, b) - a^{p-1}][b^{p-1} - L_{p-1}^{p-1}(a, b)]}{L_{p-2}^{p-2}(a, b)} \\ &\leq \frac{p(p-1)}{8} (b-a)^2 L_{p-2}^{p-2}(a, b). \end{aligned} \quad (6.3)$$

Proof. By Theorem 6.1 applied to the convex function $f(x) = x^p$ for $p \geq 1$, we have

$$\begin{aligned} 0 &\leq \frac{a^p + b^p}{2} - \frac{1}{b-a} \int_a^b x^p dx \\ &\leq \frac{[b^p - a^p - pa^{p-1}(b-a)][pb^{p-1}(b-a) - b^p + a^p]}{2p(b^{p-1} - a^{p-1})(b-a)} \\ &\leq \frac{p(b^{p-1} - a^{p-1})(b-a)}{8}. \end{aligned}$$

From the facts that

$$b^p - a^p = p(b-a)L_{p-1}^{p-1}(a, b) \quad \text{and} \quad b^{p-1} - a^{p-1} = (p-1)(b-a)L_{p-2}^{p-2}(a, b),$$

Theorem 6.2 follows. \square

Theorem 6.3 ([1, Proposition 2]). *Let $0 < a < b$. Then we have*

$$0 \leq L(a, b) - H(a, b) \leq \left(\frac{b-a}{a+b}\right)^2 L(a, b) \leq \frac{(b-a)^2}{4ab} L(a, b). \quad (6.4)$$

Proof. By Theorem 6.1 applied to the convex function $f(x) = \frac{1}{x}$ on $[a, b] \subset (0, \infty)$, we have

$$\begin{aligned} 0 &\leq \frac{1/a + 1/b}{2} - \frac{\ln b - \ln a}{b-a} \\ &\leq \frac{[1/b - 1/a + (b-a)/a^2][(a-b)/b^2 - 1/b + 1/a]}{2(b-a)(1/a^2 - 1/b^2)} \\ &\triangleq R \\ &\leq \frac{(b-a)(1/a^2 - 1/b^2)}{8}. \end{aligned}$$

However, since

$$\frac{1}{b} - \frac{1}{a} + \frac{b-a}{a^2} = \frac{(b-a)^2}{a^2b} \quad \text{and} \quad \frac{a-b}{b^2} - \frac{1}{b} + \frac{1}{a} = \frac{(b-a)^2}{ab^2},$$

it follows that

$$R = \frac{(b-a)^2}{2ab(a+b)}.$$

Consequently, we obtain

$$0 \leq \frac{1}{H(a, b)} - \frac{1}{L(a, b)} \leq \frac{(b-a)^2}{2ab(a+b)} \leq \frac{(b-a)^2(a+b)}{8a^2b^2},$$

which is equivalent to (6.4). \square

Theorem 6.4 ([1, Proposition 3]). *Let $0 < a < b$. Then*

$$0 \leq \ln \frac{I(a, b)}{G(a, b)} \leq \frac{ab[\ln(a/b) + (b-a)/a][\ln(b/a) + (b-a)/b]}{2(b-a)^2} \leq \frac{(b-a)^2}{8ab}. \quad (6.5)$$

Proof. This follows from Theorem 6.1 applied to $f(x) = -\ln x$. \square

6.3. An application to elliptic integrals. In the paper [15], Qi's integral inequality in Theorem 5.2 was applied to estimate the complete elliptic integrals of the first and second kinds

$$E(t) = \int_0^{\pi/2} \sqrt{1-t^2 \sin^2 \theta} \, d\theta \quad \text{and} \quad F(t) = \int_0^{\pi/2} \frac{d\theta}{\sqrt{1-t^2 \sin^2 \theta}} \quad (6.6)$$

for $0 < t < 1$.

Theorem 6.5 ([15, Theorems 3 and 4]). *For $0 < t < 1$, we have*

$$\begin{aligned} \left| \frac{2}{\pi} E(t) - \frac{1 + \sqrt{1-t^2}}{2} \right| \\ \leq \frac{1 - \sqrt{1-t^2}}{\pi} \left[1 - \frac{2\sqrt{(1-t^2 + \sqrt{1-t^2})(1 + \sqrt{1-t^2})}}{\pi(\sqrt{1-t^2} + 1)\sqrt[4]{1-t^2}} \right] \end{aligned} \quad (6.7)$$

and

$$\begin{aligned} \left| \frac{2}{\pi} F(t) - \frac{\sqrt{1-t^2} + 1}{2\sqrt{1-t^2}} \right| \leq \frac{1 - \sqrt{1-t^2}}{\pi\sqrt{1-t^2}} \\ \times \left[1 - \frac{2(1 - \sqrt{1-t^2})(2 - t^2 - \sqrt{t^4 - t^2 + 1})^{3/2}}{\pi\sqrt{(1-t^2)(\sqrt{t^4 - t^2 + 1} + t^2 - 1)(1 - \sqrt{t^4 - t^2 + 1})}} \right]. \end{aligned} \quad (6.8)$$

Proof. For $0 < t < 1$ and $\theta \in [0, \frac{\pi}{2}]$, let $f(\theta) = \sqrt{1-t^2 \sin^2 \theta}$. A direct calculation yields

$$\begin{aligned} f'(\theta) &= -\frac{t^2 \sin \theta \cos \theta}{\sqrt{1-t^2 \sin^2 \theta}}, \\ f''(\theta) &= -\frac{t^2(t^2 \sin^4 \theta - \sin^2 \theta + \cos^2 \theta)}{(1-t^2 \sin^2 \theta)^{3/2}} = -\frac{t^2 \sin^4 \theta (t^2 - 1 + \cot^4 \theta)}{(1-t^2 \sin^2 \theta)^{3/2}}. \end{aligned}$$

Hence, the function $f'(\theta)$ has a unique minimum

$$-\frac{t^2 \sqrt[4]{1-t^2}}{\sqrt{(1-t^2 + \sqrt{1-t^2})(1 + \sqrt{1-t^2})}}$$

at

$$\theta = \arctan \frac{1}{\sqrt[4]{1-t^2}}.$$

Therefore, the maximum of $f'(\theta)$ is

$$\lim_{\theta \rightarrow 0^+} f'(\theta) = \lim_{\theta \rightarrow (\pi/2)^-} f'(\theta) = 0.$$

Moreover, we have

$$f(0) = 1 \quad \text{and} \quad f\left(\frac{\pi}{2}\right) = \sqrt{1-t^2}.$$

Substituting quantities above into (5.19) and simplifying lead to (6.7).

For $0 < t < 1$ and $\theta \in [0, \frac{\pi}{2}]$, let

$$h(\theta) = \frac{1}{\sqrt{1-t^2 \sin^2 \theta}}.$$

A straightforward calculation gives

$$h'(\theta) = \frac{t^2 \sin \theta \cos \theta}{(1-t^2 \sin^2 \theta)^{3/2}},$$

$$\begin{aligned} h''(\theta) &= -\frac{t^2(\sin^2\theta - \cos^2\theta - t^2\sin^4\theta - 2t^2\cos^2\theta\sin^2\theta)}{(1-t^2\sin^2\theta)^{5/2}} \\ &= -\frac{t^2[t^2\sin^4\theta + 2(1-t^2)\sin^2\theta - 1]}{(1-t^2\sin^2\theta)^{5/2}}. \end{aligned}$$

Hence, the function $h'(\theta)$ has a unique maximum

$$\frac{\sqrt{(\sqrt{t^4-t^2+1}+t^2-1)(1-\sqrt{t^4-t^2+1})}}{(2-t^2-\sqrt{t^4-t^2+1})^{3/2}}$$

at

$$\theta = \arcsin \frac{\sqrt{\sqrt{t^4-t^2+1}+t^2-1}}{t}.$$

Therefore, the minimum of $h'(\theta)$ is

$$\lim_{\theta \rightarrow 0^+} h'(\theta) = \lim_{\theta \rightarrow (\pi/2)^-} h'(\theta) = 0.$$

Moreover, we have

$$h(0) = 1 \quad \text{and} \quad h\left(\frac{\pi}{2}\right) = \frac{1}{\sqrt{1-t^2}}.$$

Substituting quantities above into (5.19) and simplifying lead to (6.8). The proof of Theorem 6.5 is complete. \square

Remark 6.1. In [46], the inequality (5.19) was replaced by Lupaş' integral inequality

$$\begin{aligned} \left| \frac{1}{b-a} \int_a^b f(t)g(t) dt - \frac{1}{b-a} \int_a^b f(t) dt \frac{1}{b-a} \int_a^b g(t) dt \right| \\ \leq \frac{b-a}{\pi^2} \|f'\|_2 \|g'\|_2, \quad (6.9) \end{aligned}$$

where $f', g' \in L_2([a, b])$ and

$$\|h\|_2 = \left[\int_a^b |h(t)|^2 dt \right]^{1/2}, \quad h \in L_2([a, b]),$$

for finding some new inequalities for the complete elliptic integrals of the first and second kinds.

7. ACKNOWLEDGEMENTS

The author would like to express his heartily thanks to the following peoples:

- (1) Members of the author's family.
- (2) Teachers and colleagues in the author's life.
- (3) Professor Sever S. Dragomir who arranged in June 2002 to send the author some papers he authored.
- (4) Professor Milan Merkle who mailed the author in June 2002 the papers [30, 43, 44].
- (5) Dr. Tibor K. Pogány who mailed the author in June 2002 the papers [29, 30, 43] and others.
- (6) Professor Bit-Shun Tam who arranged in June 2002 to send the author the paper [10].
- (7) Librarian Aruna Arora, Professor Girdhar G. Agarwal, and Dr. Usha Mujoo-Munshi, three Indians, who arranged in July 2002 to e-mail the author scanned copies of the papers [19, 28] respectively.
- (8) Professor Zheng Liu who sent the author on 10 October 2002 the paper [42] which was obtained from Uppsala University Library.

- (9) Some Croatians who faxed the author on 26 June 2003 the papers [6, 20].
- (10) Ms. Jing-Fen Ruan, a graduate at Tamkang University, who mailed the author in December 2004 the paper [8].
- (11) Dr. Sen-Lin Guo, the author's classmate at Henan University, who mailed the author from Canada the papers [1, 2, 11] in December 2004.
- (12) The Tōhoku Mathematical Journal who provided the author the original copy of the paper [35].
- (13) Professor Gholamreza Alirezaei and Vladimir Jovanovic who translated and outlined respectively the paper [35] from old German into English.
- (14) Many other kind peoples who ever gave the author valuable helps but are not remembered clearly and accurately.

REFERENCES

- [1] R. P. Agarwal and S. S. Dragomir, *An application of Hayashi inequality for differentiable functions*, Computers Math. Appl. **32** (1996), no. 6, 95–99; Available online at [http://dx.doi.org/10.1016/S0898-1221\(96\)00146-0](http://dx.doi.org/10.1016/S0898-1221(96)00146-0).
- [2] R. P. Agarwal, V. Čuljak, and J. E. Pečarić, *Some integral inequalities involving bounded higher order derivatives*, Math. Comput. Modelling **28** (1998), no. 3, 51–57; Available online at [http://dx.doi.org/10.1016/S0895-7177\(98\)00098-3](http://dx.doi.org/10.1016/S0895-7177(98)00098-3).
- [3] P. S. Bullen, *Handbook of Means and Their Inequalities*, Mathematics and its Applications, Volume 560, Kluwer Academic Publishers, Dordrecht/Boston/London, 2003.
- [4] P. Cerone, *Generalised trapezoidal rules with error involving bounds of the n -th derivative*, Math. Inequal. Appl. **5** (2002), no. 3, 451–462; Available online at <http://dx.doi.org/10.7153/mia-05-44>.
- [5] P. Cerone and S. S. Dragomir, *Lobatto type quadrature rules for functions with bounded derivative*, Math. Inequal. Appl. **3** (2000), no. 2, 197–209; Available online at <http://dx.doi.org/10.7153/mia-03-23>.
- [6] V. Čuljak and N. Elezović, *A note on Steffensen and Iyengar inequality*, Glas. Mat. Ser. III **33** (53) (1998), no. 2, 167–171.
- [7] Department of Mathematics, East China Normal University, *Mathematical Analysis*, 3rd ed., Higher Education Press, Beijing, China, June 2001. (Chinese)
- [8] S. S. Dragomir, Y. J. Cho, and S. S. Kim, *Some remarks on Milovanović-Pečarić inequality and applications for special means and numerical integrations*, Tamkang J. Math. **30** (1999), no. 3, 203–211; Available online at <http://dx.doi.org/10.5556/j.tkjm.30.1999.203-211>.
- [9] S. S. Dragomir and C. E. M. Pearce, *Selected Topics on Hermite-Hadamard Type Inequalities and Applications*, RGMIA Monographs, Victoria University, 2000; Available online at http://rgmia.org/monographs/hermite_hadamard.html.
- [10] S. S. Dragomir and S. Wang, *Applications of Iyengar type inequalities to the estimation of error bounds for the trapezoidal quadrature rule*, Tamkang J. Math. **29** (1998), no. 1, 55–58; Available online at <http://dx.doi.org/10.5556/j.tkjm.29.1998.55-58>.
- [11] N. Elezović and J. E. Pečarić, *Steffensen inequality and estimates of error in trapezoidal rule*, Appl. Math. Lett. **11** (1998), no. 6, 63–69; Available online at [http://dx.doi.org/10.1016/S0893-9659\(98\)00104-9](http://dx.doi.org/10.1016/S0893-9659(98)00104-9).
- [12] A. M. Fink, *An essay on the history of inequalities*, J. Math. Anal. Appl. **249** (2000), 118–134; Available online at <http://dx.doi.org/10.1006/jmaa.2000.6934>.
- [13] B.-N. Guo and F. Qi, *A simple proof of logarithmic convexity of extended mean values*, Numer. Algorithms **52** (2009), no. 1, 89–92; Available online at <http://dx.doi.org/10.1007/s11075-008-9259-7>.
- [14] B.-N. Guo and F. Qi, *Proofs of an integral inequality*, Mathematics and Informatics Quarterly **7** (1997), no. 4, 182–184.
- [15] B.-N. Guo and F. Qi, *Some bounds for the complete elliptic integrals of the first and second kinds*, Math. Inequal. Appl. **14** (2011), no. 2, 323–334; Available online at <http://dx.doi.org/10.7153/mia-14-26>.
- [16] B.-N. Guo and F. Qi, *The function $(b^x - a^x)/x$: Logarithmic convexity and applications to extended mean values*, Filomat **25** (2011), no. 4, 63–73; Available online at <http://dx.doi.org/10.2298/FIL1104063G>.
- [17] G. H. Hardy, J. E. Littlewood, and G. Pólya, *Inequalities*, Cambridge University Press, 1934.
- [18] T. Hayashi, *On curves with monotonous curvature*, Tōhoku Math. J. **15** (1919), 236–239.
- [19] K. S. K. Iyengar, *Note on an inequality*, Math. Student **6** (1938), 75–76.
- [20] P. K. Menon, *Some integral inequalities*, Math. Student **11** (1943), 36–38.

- [21] G. Klambauer, *Mathematical Analysis*, Pure and Applied Mathematics Series **31**, Marcel Dekker, New York, 1975. Chinese Edition, translated by Ben-Wang Sun, Hunan People Press, Changsha City, 1981.
- [22] G. Klambauer, *Problems and Propositions in Analysis*, Lecture Notes in Pure and Applied Mathematics **49**, Marcel Dekker, New York and Basel, 1979.
- [23] J.-C. Kuang, *Chángyòng Bùděng Shì (Applied Inequalities)*, Hunan Education Press, Changsha City, Hunan Province, China, 1989. (Chinese)
- [24] J.-C. Kuang, *Chángyòng Bùděng Shì (Applied Inequalities)*, 2nd ed., Hunan Education Press, Changsha City, Hunan Province, China, 1993. (Chinese)
- [25] J.-C. Kuang, *Chángyòng Bùděng Shì (Applied Inequalities)*, 3rd ed., Shandong Science and Technology Press, Ji'nan City, Shandong Province, China, 2004. (Chinese)
- [26] Z. Liu and Y.-X. Shi, *Note on Iyengar type integral inequalities*, J. Anshan Univ. Sci. Tech. **26** (2003), no. 4, 318–320. (Chinese)
- [27] Z.-F. Lu, *Gāoděng Shùxué Jiěxī Dàquán*, Liaoning Science and Technology Press, Shenyang City, China, 1991. (Chinese)
- [28] G. S. Mahajani, *A note on an inequality*, Math. Student **6** (1938), 125–128.
- [29] M. Matić, J. E. Pečarić, and N. Ujević, *On new estimation of the remainder in generalised Taylor formula*, Math. Inequal. Appl. **2** (1999), no. 3, 343–361; Available online at <http://dx.doi.org/10.7153/mia-02-31>.
- [30] G. V. Milovanović and J. E. Pečarić, *Some considerations on Iyengar inequality and some related applications*, Univ. Beograd. Publ. Elektrotehn. Fak. Ser. Mat. Fiz. **544–576** (1976), 166–170.
- [31] D. S. Mitrinović, *Analytic Inequalities*, Springer, New York-Heidelberg-Berlin, 1970.
- [32] D. S. Mitrinović, *Analytic Inequalities*, Chinese Ed., Translated by X.-P. Zhang and L. Wang, Science Press, Beijing, 1987.
- [33] D. S. Mitrinović, J. E. Pečarić, and A. M. Fink, *Classical and New Inequalities in Analysis*, Kluwer Academic Publishers, 1993.
- [34] C. P. Niculescu and L.-E. Persson, *Convex Functions and their Applications*, CMS Books in Mathematics, Springer-Verlag, 2005.
- [35] G. Pólya, *Ein mittelwertsatz für Funktionen mehrerer Veränderlichen*, Tôhoku Math. J. **19** (1921), 1–3.
- [36] G. Pólya and G. Szegő, *Aufgaben und Lehrsätze aus der Analysis*, Volume I, Springer-Verlag, Berlin, 1925. (German)
- [37] G. Pólya and G. Szegő, *Problems and Theorems in Analysis*, Volume I, Classics in Mathematics, Springer-Verlag, Berlin, 1972.
- [38] G. Pólya and G. Szegő, *Problems and Theorems in Analysis*, Volume I, Chinese Edition, 1984.
- [39] F. Qi, *Inequalities for an integral*, Math. Gaz. **80** (1996), no. 488, 376–377; Available online at <http://www.jstor.org/stable/3619581>.
- [40] F. Qi, Z.-L. Wei, and Q. Yang, *Generalizations and refinements of Hermite-Hadamard's inequality*, Rocky Mountain J. Math. **35** (2005), no. 1, 235–251; Available online at <http://dx.doi.org/10.1216/rmj/1181069779>.
- [41] J. F. Steffensen, *On certain inequalities between mean values, and their application to actuarial problems*, Scandinavisk Aktuarietidskrift (1918), 82–97.
- [42] J. F. Steffensen, *On certain inequalities and methods of approximation*, Scandinavisk Aktuarietidskrift (1919), 274–297.
- [43] P. M. Vasić and G. V. Milovanović, *On an inequality of Iyengar*, Univ. Beograd. Publ. Elektrotehn. Fak. Ser. Mat. Fiz. **544–576** (1976), 18–24.
- [44] P. M. Vasić and J. E. Pečarić, *Note on the Steffensen inequality*, Univ. Beograd. Publ. Elektrotehn. Fak. Ser. Mat. Fiz. **716–734** (1981), 80–81.
- [45] L.-Z. Xu and X.-H. Wang, *Shùxué Fēnāi Zhōng de Fāngfǎ hé Lìtì Xuānjiǎng (Selected Methods and Examples of Mathematical Analysis)*, Rev. Ed., Higher Education Press, Beijing, China, 1983. (Chinese)
- [46] L. Yin and F. Qi, *Some inequalities for complete elliptic integrals*, available online at <http://arxiv.org/abs/1301.4385>.

DEPARTMENT OF MATHEMATICS, SCHOOL OF SCIENCE, TIANJIN POLYTECHNIC UNIVERSITY, TIANJIN CITY, 300387, CHINA; SCHOOL OF MATHEMATICS AND INFORMATICS, HENAN POLYTECHNIC UNIVERSITY, JIAOZUO CITY, HENAN PROVINCE, 454010, CHINA

E-mail address: qifeng618@gmail.com, qifeng618@hotmail.com, qifeng618@qq.com

URL: <http://qifeng618.wordpress.com>