

 Open access • Journal Article • DOI:10.1109/TNS.1976.4328248

Position Sensing by Charge Division — Source link

J. L. Alberi, Veljko Radeka

Institutions: Brookhaven National Laboratory

Published on: 01 Feb 1976 - IEEE Transactions on Nuclear Science (IEEE)

Topics: Capacitive sensing, Resistive touchscreen, Voltage, Electrical impedance and Capacitance

Related papers:

- [Signal, Noise and Resolution in Position-Sensitive Detectors](#)
- [One and Two Dimensional Position Sensing Semiconductor Detectors](#)
- [On the charge dividing mechanism in position sensitive detectors](#)
- [New Type of Position-Sensitive Detectors of Ionizing Radiation Using Risetime Measurement](#)
- [On the ballistic deficit and the signal-to-noise ratio of semiconductor spectrometers for energy and position spectroscopy](#)

Share this paper:    

View more about this paper here: <https://typeset.io/papers/position-sensing-by-charge-division-2ywkm1qfn>

To be published in
IEEE Trans. on Nucl. Sci.

Presented at IEEE Nuclear Science
Symposium, 19-21 November 1975,
Sheraton-Palace, San Francisco.

BNL 20720

Conf-75116--24

POSITION SENSING BY CHARGE DIVISION^{*†}

J. L. Alberi and V. Radeka

Brookhaven National Laboratory
Upton, New York 11973

November 1975

*Research carried out under the auspices of Energy
Research and Development Administration.

†This paper is an abbreviated version of a more complete
report that will be published elsewhere.

MASTER

POSITION SENSING BY CHARGE DIVISION**

J. L. Alberi and V. Radeka

Brookhaven National Laboratory
Upton, New York 11973

NOTICE

This report was prepared as an account of work sponsored by the United States Government. Neither the United States nor the United States Energy Research and Development Administration, nor any of their employees, nor any of their contractors, subcontractors, or their employees, makes any warranty, express or implied, or assumes any legal liability or responsibility for the accuracy, completeness or usefulness of any information, apparatus, product or process disclosed, or represents that its use would not infringe privately owned rights.

ABSTRACT

A summary of a comprehensive analysis of theoretical and practical aspects of position sensing by charge division from resistive electrodes is presented. Properties of transformer decoupling of the resistive electrode from detector bias voltage are analyzed and compared to the usual capacitive decoupling methods. Optimization and limitation of signal shaping is discussed as a function of diffusion time constant, signal rise times, and noise.

Introduction

Resistive electrodes have been used in various forms for position sensing in nuclear particle and radiation detectors. There are two basically different methods for sensing the position of particle impact with resistive electrodes. Due to the distributed electrode capacitance, the resistive electrode represents a diffusive RC line. In the charge division method the position is determined by the ratio of the charge flowing out of one end of the resistive electrode terminated into a low impedance and the total charge. In the so-called rise time method, the resistive electrode represents a part of an infinite diffusive line (if it is terminated into its characteristic impedance). The position is determined from the difference in the signal diffusion time from the point where the charge is injected to the ends of the electrode.

The use of charge division with semiconductor detectors was first proposed by Louterjung *et al.*¹ Subsequently, the method was used with spark chambers by Charpak *et al.*² It seems that the idea originated independently in different fields. As far as we could determine, position sensing by charge division was first observed in resistive electrodes of photodetectors by Schottky³ in 1930. Position sensing by the diffusion time method ("rise time" method) was introduced by Borkowsky and Kopp⁴.

Resistive electrodes for position sensing have been used with a number of different types of particle and radiation detectors. Semiconductor detectors with resistive electrodes have been developed for use in magnetic spectrometers^{5,6,7,8}. Single wire proportional detectors with resistive anodes have been used for x-ray, charged particle and neutron detection^{9,10,11}. Two-dimensional proportional detectors with serial zig-zag connection of the wires forming an electrode plane have been developed^{9,12,13}. Resistive sheets have been used for two-dimensional position sensing with microchannel

plate electron multipliers^{14,15}. The importance of position sensing along the anode wire in multiwire proportional chambers for use in high energy physics has recently been emphasized, since it provides an unambiguous position readout for multiple particles. The use of charge division in this area has been demonstrated^{16,17}. The first large scale use of MWPC's with charge division is in an experiment at the CERN ISR¹⁸. Resistive electrodes have also been used in position-sensitive photodetectors¹⁹. The development in this area had no connection to the development of nuclear particle detectors until recently.

When using position sensing with resistive electrodes the choice has to be made between the charge division and the diffusion time method. There is a basic difference between the two methods, and there are some differences in the practical aspects of implementation. The diffusion time method requires uniformity and stability of both the electrode resistance and capacitance, since the time versus position scale is determined by the product of the resistance and the capacitance ($R_p C_p$). In the charge division method, the position is determined as the ratio of resistances. Thus the position is determined independently of variations of the electrode resistance (with temperature, for example). Nonuniform distribution of electrode capacitance is allowed, which is important in applications involving series connection of two wires in multiwire proportional chambers. The resolving time for the charge division method is about one electrode time constant $\tau_D = R_p C_p$, for optimum position resolution and linearity. The resolving time for the diffusion time method is several times τ_D . The charge division method is inherently linear with optimum filtering. The diffusion time method is nearly linear provided the diffusive line is terminated into its characteristic impedance and preamplifiers with high input impedance (and short connections to the detector) are used. The charge division method requires preamplifiers with low input impedance, and they can be some distance away from the detector. The diffusion time method is not suitable for detectors with long and variable charge collection time, which impairs the timing accuracy, while the charge division is independent of the charge collection time. The charge division requires a divider either in hardware or in software, while the diffusion time method requires only a time digitizer. This last point is sometimes decisive in making the choice.

We feel that due to all the other advantages the charge division is a method of choice for a number of important applications, in particular, for multiwire

* Research carried out under the auspices of Energy Research and Development Administration.

† This paper is an abbreviated version of a more complete report that will be published elsewhere.

20

proportional detectors. For readers wishing to pursue further the diffusion time method, excellent descriptions and further bibliography are given in Refs. 4, 5, 9, 20, and 21. Analysis of some aspects of charge division is given in Refs. 5, 22, and 23. A fast and accurate logarithmic divider has been developed and extensively used¹². A dividing analog-to-digital converter was developed by Miller *et al.*²⁴. A somewhat slower divider is commercially available (Ortec).

While the charge division method is very simple in principle, the optimization of preamplifiers, coupling networks and pulse shaping with respect to position resolution and linearity is quite complicated. The purpose of this paper is to provide an understanding of the method and to give an analysis of the sources of errors, which leads to optimum solutions. Practical design criteria for coupling networks and preamplifiers are given. It is striking that even with this simple method of position sensing, optimum circuits are quite different for various applications. In this, the ratio of the charge collection time to the electrode time constant $\tau_D = R_D C_D$, and the electrode capacitance and resistance are the most important determining parameters.

Division of Charge in Diffusive RC Lines

In position sensitive detectors with resistive electrodes the signal charge is injected or induced somewhere along the electrode. It can be shown that the position determined by the charge division method corresponds to the centroid of the charge injected or imaged on the resistive electrode. Due to the diffusive nature of the line, it takes time after a charge is injected until the charge arrives at the ends of the line, *i.e.*, until the ratio of charge is established according to the ratio of dc resistances of the electrode. The minimum measurement (or filtering) time is determined by the accuracy of position determination required. Thus, we are interested first in determining the position error, that is position signal nonlinearity as a function of the measurement time.

Figure 1 shows four different circuit configurations in which the position signals Q_1 , Q_2 , $Q_1 - Q_2$ and the charge amplitude (particle energy) signal, $Q_1 + Q_2$, can be obtained. The properties of these circuit configurations with respect to electrode and amplifier dc voltage decoupling, $Q_1 + Q_2$ sum formation, noise and practical realization aspects will be discussed in later sections. The charge diffusion as a function of time is first determined assuming that the resistive electrode is terminated at both ends into impedances which are negligible compared to the total resistance R_D of the resistive electrode. The effects of finite amplifier input impedance and of decoupling networks will be discussed separately. The diffusive line parameters important in determining the nonlinearity, noise, and termination (decoupling network) effects are

$$\begin{aligned} R_D &= R \cdot \ell \\ C_D &= C \cdot \ell \\ \tau_D &= R_D C_D = RC \ell^2 \end{aligned} \quad (1)$$

where R and C are resistance and capacitance per unit length, ℓ is the length of the line, and τ_D is the product of the total line resistance and capacitance (the line "time constant").

By solving the diffusion equation for this case, the charge at the ends of the line can be expressed as series expansions,

$$\frac{Q_1}{Q_S} = x + \frac{2}{\pi} \sum_{n=1}^{\infty} \frac{(-1)^n}{n} e^{-n^2 \pi^2 \tau / \tau_D} \sin n \pi x \quad (2)$$

$$\frac{Q_2}{Q_S} = 1 - x + \frac{2}{\pi} \sum_{n=1}^{\infty} \frac{(-1)^n}{n} e^{-n^2 \pi^2 \tau / \tau_D} \sin n \pi (1-x) \quad (3)$$

where Q_S is the charge injected into the line and x is the distance from the left end of the line expressed as a fraction of the line length. From these series we obtain for the sum and for the difference,

$$\frac{Q_1 + Q_2}{Q_S} = 1 - \frac{2}{\pi} \sum_{n=1}^{\infty} \frac{1 - (-1)^n}{n} e^{-n^2 \pi^2 \tau / \tau_D} \sin n \pi x \quad (4)$$

$$\frac{Q_2 - Q_1}{Q_S} = 1 - 2x - \frac{2}{\pi} \sum_{n=1}^{\infty} \frac{1 + (-1)^n}{n} e^{-n^2 \pi^2 \tau / \tau_D} \sin n \pi x \quad (5)$$

The signal waveforms are obviously position dependent. To avoid a nonlinearity due to this, the overall filter weighting function must provide uniform weighting for the time required for the time dependent terms to decrease to an acceptable error. The weighting function must not have any infinitely steep parts since this would make the (series) amplifier noise high. These requirements result in trapezoidal weighting functions introduced previously²³. The form of this function is determined by the relation of the (parallel) noise generated in the resistive electrode and the amplifier (series) noise. Such a function is shown in the inset in Fig. 2. For errors to be small (less than 10^{-2}), constant weighting will have to be applied for times longer than $\tau / \tau_D \approx 10^{-1}$. Then, the series (2), (4), and (5) converge rapidly, and the remaining terms are,

$$\frac{Q_1}{Q_S} \approx x - \frac{2}{\pi} e^{-\pi^2 \tau / \tau_D} \sin \pi x \quad (6)$$

$$\frac{Q_1 + Q_2}{Q_S} \approx 1 - \frac{4}{\pi} e^{-\pi^2 \tau / \tau_D} \sin \pi x \quad (7)$$

$$\frac{Q_2 - Q_1}{Q_S} \approx 1 - 2x - \frac{4}{\pi} e^{-4\pi^2 \tau / \tau_D} \sin 2\pi x \quad (8)$$

The errors in Q_1/Q_S and in $(Q_1 + Q_2)/Q_S$ converge with the same time dependence. It is interesting to note that the error in $(Q_2 - Q_1)/Q_S$ becomes the same as in Q_1/Q_S but in one quarter of the time. The quantities measured after filtering can be obtained by the convolution of the above series with the trapezoidal function, and the significant terms of the series can be written

in the form,

$$\frac{A}{Q_S} \approx x - k \sin \pi x \quad (9)$$

$$\frac{A+B}{Q_S} \approx 1 - 2k \sin \pi x \quad (10)$$

$$k = \frac{2\tau_D}{h\tau_F\pi} e^{-\pi^2(1-h)\tau_F/\tau_D} \left(e^{-\pi^2 h\tau_F/\tau_D} - 1 \right) \quad (11)$$

where k is the position error parameter, τ_F is the width of the trapezoidal weighting function, $h\tau_F$ is the width of the sloped part of this function, and A and $A+B$ are the quantities measured at the output of the filters by a peak sensing or a sampling device (analog-to-digital converter or stretcher).

A/Q_S is shown in Fig. 2 for $h = 0.2$. The position error parameter k is plotted in Fig. 3. The position error after division $A/A+B$ is given by,

$$\frac{A}{A+B} - x \approx -k(1-2x) \sin \pi x \quad (12)$$

and it is plotted in Fig. 4. It can be shown that the same function with opposite sign applies for the position error in the difference measurement $(B-A)/(A+B)$, for equal pulse shaping applied to $(B-A)$ and $(A+B)$.

From the accuracy (linearity) requirements, the minimum width of the weighting function can be determined. At $\tau_F/\tau_D = 1/2$ the maximum fractional error is $\approx 7 \times 10^{-3}$. It decreases rapidly with increasing τ_F , so that at $\tau_F/\tau_D = 1$, it becomes $\approx 2.6 \times 10^{-4}$. Here the charge division method can be considered inherently linear.

Noise, Filtering and Position Resolution

Noise added to the position and charge signals determines the position resolution. The diffusive line represents a dissipative position-sensing medium, and its noise is inherently present with the signal. In addition to this, noise is generated in the amplifiers for the position signal and for the charge (energy) signal. The amplifier noise can be made negligible in most cases by proper design of the input circuits and of the weighting function.

In general, the noise of the sum signal is smaller than the noise of the position signal since most of the noise generated by the resistive electrode is cancelled by summing the outputs from the two ends of the electrode. The noise in the sum $(A+B)$ channel is important since it adds to the position noise when the division is performed. This also becomes important when good energy resolution is needed (as with germanium position sensitive detectors).

Added to the position signal Q_1 or $Q_2 - Q_1$ is the noise generated by the resistive electrodes. This noise source appears in parallel with the input of the amplifier for Q_1 in Fig. 1. For $\tau_F \approx 0.5 \tau_D$ the effect of the capacitance of the diffusive line can be neglected. Then the equivalent noise charge is given by²³,

$$\overline{ENC}_p^2 \approx \frac{1}{2} i_n^2 \frac{\tau_F}{n} a_{F2} \tau_F = 2kT \frac{1}{R_D} a_{F2} \tau_F \quad \text{for } \tau_F \approx \frac{1}{2} \tau_D \quad (13)$$

$$\text{where } a_{F2} \tau_F = \int_{-\infty}^{\infty} [w(t)]^2 dt \quad (14)$$

τ_F is the width of the weighting function, and a_{F2} is a nondimensional form factor. For the unipolar trapezoidal function assumed, $a_{F2} = 0.733$, and

$$\overline{ENC}_p^2 \approx 1.47 kT \frac{\tau_F}{R_D} \quad \text{for } \tau_F \approx \frac{1}{2} \tau_D \quad (15)$$

If we set $\tau_F = 0.8\tau_D$ so that the flat top of the trapezoidal function is equal to $1/2 \tau_D$, we get for the minimum noise from the resistive electrode,

$$\overline{ENC}_p^2 \approx 1.17 kT \frac{\tau_D}{R_D} = 1.17 kT C_D \quad (16)$$

The best position resolution due to only the resistive electrode noise is then,

$$\frac{\Delta x}{x} \approx 2.35 \frac{ENC_p}{Q_S} = 2.54 \frac{(kTC_D)^{1/2}}{Q_S} \quad (\text{FWHM}) \quad (17)$$

This resolution can usually be realized for low capacitance, high resistance electrodes, where circuit configurations in Figs. 1(a) and 1(d) are applicable. As will be shown in a later section, transformer decoupling with common-base input stage has practical advantages in detectors with many wires and where the electrode resistance is low.

The noise analysis for circuit configurations in Figs. 1(b) and 1(c) is quite complicated, and only the noise results are presented here. The noise contribution by the common base stage is minimum when the contributions by the base current shot noise and the collector current shot noise are equal. This "matched" condition is achieved for,

$$\left(\frac{r_e}{R_D} \right)_{\text{opt}} = \frac{n^2}{h f_e^{1/2}} \left(1 + \frac{a_{F1}}{a_{F2}} \frac{\tau_C^2}{\tau_F^2} \right)^{-1/2} \quad (18)$$

where $r_e = \frac{kT}{eI_E}$ is the emitter dynamic resistance, n is

the secondary/primary transformation ratio, $h f_e$ is the transistor small signal current gain, $\tau_C = R_D C_D + n^2 R_D C_A$, C_A is the stray capacitance at the input of the amplifier and a_{F1} is the weighting function form factor for series noise, given by²³

$$\frac{a_{F1}}{\tau_F} = \int_{-\infty}^{\infty} [w'(t)]^2 dt \quad (19)$$

The minimum noise is then,

$$ENC_{min}^2 = 2kT \frac{1}{R_D} a_{F2} \tau_F \left[1 + \frac{1}{h_{fe}} \left[1 + \frac{a_{F1}}{a_{F2}} \frac{\tau_C}{\tau_F} \right] \right] \quad (20)$$

In these results it is assumed that the effects of the transformer's inductance are negligible, that is, $L/R_D > \tau_F$. If this is not satisfied, an increase in noise at low frequencies results due to the emitter current shot noise, because of a lower impedance in the emitter circuit. This type of noise becomes divergent at low frequencies, and thus it requires a bipolar filter weighting function (second order low frequency cutoff). A bipolar weighting function is also desirable to reduce baseline fluctuations at high event rates in applications where baseline restoration and pole-zero cancellation are impractical.

As an example, we assume a resistive electrode with $R_D = 3000\Omega$, $C_D = 100$ pF, $\tau_D = 0.3$ μ sec, trapezoidal filter with $\tau_F = 0.25$ μ sec, $h_{fe} = 100$. Form factors $a_{F1} = 40$ and $a_{F2} = 0.733$. The noise due to the resistive electrode is,

$$ENC_p = 4.4 \times 10^3 \text{ rms electrons.}$$

The noise increase factor due to the amplifier, from Eq. (20), is 1.07. To achieve a position resolution of 1% FWHM, a signal $Q_S \approx 1.1 \times 10^6$ electrons is required.

The noise added to the charge (energy) signal in the sum channel is generated partly in the amplifier for $Q_1 + Q_2$ and partly in the resistive electrode. The resistive electrode as seen by the sum amplifier (in Fig. 1(d), for example) can be represented approximately by the electrode capacitance, C_D , in series with a resistance, $R_D/2$. The noise due to these two sources appears to be in series with the detector as a capacitive signal source. The equivalent noise charge is then approximately given by²³,

$$ENC_s^2 \approx 2kT(R_S + R_D/2)(C_A + C_D)^2 \frac{a_{F1}}{\tau_F} \quad (21)$$

where a_{F1} is the weighting function form factor for series noise given by Eq. (19), R_S is the amplifier equivalent series noise resistance and C_A is the input stray capacitance. From the expressions for noise in the position channel, Eqs. (13) and (20) and in the energy channel, Eq. (21), and from the expressions for the two weighting function form factors, Eqs. (14) and (19), the shape of the trapezoidal weighting function can be optimized. The minimum width of the flat top is determined from the linearity condition. The width of sloped parts is made only as wide as necessary to make the contribution by the series noise sources to both the position and the sum signal small.

In some cases, particularly where $\tau_F \approx 1/2 \tau_D$ and C_D or C_A is large, the noise in the sum channel can be as high as 1/2 the noise in the position channel. The position variance, after the division $A/A+B$, can be shown to be,

$$\overline{s_x^2} \approx \frac{1}{Q_S^2} \left[\overline{q_A^2} + x^2 \overline{q_{A+B}^2} - 2x K_{A,A+B}(0) \right] \quad (22)$$

where $K_{A,A+B}(0)$ is the cross correlation coefficient of the position channel noise and the sum channel noise. The position dependence of the position resolution is illustrated in Fig. 5 for the case,

$\frac{\tau_D}{\tau_F} = \frac{1}{4} \frac{\tau_C}{\tau_F}$. Several peaks of equal area are shown in the upper half of the position scale. Only the peaks at the upper end of the scale are affected, where maximum broadening of the position peak is $\approx 12\%$.

Signal Waveform and Filter Optimization

In all discussions of the linearity requirements and the position resolution so far, it was assumed that the signal current is an impulse (delta function). With most detectors this is not the case. It can be shown that the charge collection time (i.e., the current signal width) can be larger than the weighting function width without affecting the linearity of the ratio $A/A+B$ with position, provided that the weighting function in both channels, A and A+B, is the same. Thus, the charge division method is insensitive to variations in the charge collection time.

The weighting function width has to be chosen so as to satisfy the linearity requirement $\tau_F \geq \frac{1}{2} \tau_D$ and to maximize the ratio of the signal and noise at the output of the filter. Thus, for charge collection times shorter than $1/2 \tau_D$, the position resolution remains the same as for an impulse. For longer charge collection times the optimum width of the weighting function and the best position resolution are determined by the signal current waveform. We assume here as an example signal current of the form,

$$i_{in} = \frac{Q_S}{\tau_R} e^{-t/\tau_R} \text{ for } t > 0 \quad (23)$$

Normalized spatial resolution (calculated and measured) as a function of the ratio τ_F/τ_R is shown in Fig. 6. Optimum value of this ratio is $(\tau_F/\tau_R)_{opt} = 1.78$, and the optimum normalized spatial resolution function value is 2.58. This leads to an optimum signal to noise ratio of,

$$\left(\frac{\overline{s_x^2}}{x^2} \right)_{opt} = \left(\frac{N^2}{S^2} \right)_{opt} = \frac{2.90}{Q_S^2} \frac{kT}{R_D} \tau_F \quad (24)$$

An important current waveform, which arises in gas proportional detectors is,

$$i_{in} = \frac{Q_S}{\tau_n(1 + \tau_m/\tau_o)} (1 + t/\tau_o)^{-1} \quad (25)$$

where Q_S is the total charge observed at the time t_m when positive ions reach the cathode, and τ_o is the time parameter determined by the mobility of positive ions, radii of anode and cathode and the voltage between them. The best position resolution for this case occurs for $\tau_F/\tau_o \approx 4$.

In both cases, the noise would be decreased, and the position resolution improved, if τ_D were increased to a new value $2\tau_D$ by increasing the resistance R_D of the resistive electrode.

Circuit Configurations and Resistive Electrode Design Considerations

We shall first discuss methods of decoupling preamplifiers attached to the detector from each other's operating conditions as well as from any bias voltages present on the electrode. Figure 1 shows four practical methods for decoupling preamplifiers. Three of them, Figs. 1(a), (b), (c), derive the position and total charge (particle energy) information from one electrode. The fourth, Fig. 1(d), uses two electrodes in the detector. In the first method with capacitive decoupling the charge (energy) signal has to be obtained by summing preamplifier or shaping amplifier outputs. An accurate equalization of the gain for both channels, Q_1 and Q_2 , has to be performed. Otherwise, a non-linearity in the ratio $A/A+B$ with position is introduced. In the other three methods an accurate summing is performed before any amplification, by the transformers in Figs. 1(b) and (c), and by the opposite electrode in Fig. 1(d). The summing is accurate in Figs. 1(b) and (c) since the whole signal charge is passed, after charge division in the resistive electrode, into the summing preamplifier.

The circuit in Fig. 1(a) is subject to a position nonlinearity under certain conditions. In this circuit the charge initially divides according to the ratio of resistances with respect to the point of injection. For equal decoupling capacitances, C_D , the charge is eventually distributed equally to the two amplifiers. The error is proportional to $\tau_F/C_D R_D$. This error can usually be made small. However, with low values of R_D ($\approx 10^3 \Omega$), large values of C_D are required ($\approx 0.1 \mu F$). If the resistive electrode has to be at a high potential, for detector construction reasons, such capacitors become impractical in detectors with many wires and readout channels. In such cases transformer decoupling is easier to implement.

There are fixed offsets in the $A/A+B$ ratio due to a finite input impedance of the preamplifiers. A low, stable, and reproducible input impedance is easily achieved in large scale production with transformer coupled common base input stage shown in Figs. 1(b) and (c).

From the discussion of noise, it is obvious that the lowest noise is achieved with configurations in Figs. 1(a) and (d).

Finally, a position error is possible if a voltage change due to the signal is allowed to occur in either the resistive electrode, or in the opposite electrode. Such a voltage change induces a charge uniformly distributed along the resistive electrode (and therefore with its centroid in the middle of the electrode). Associated with position dependent response of Q_1 with time, the voltage change results in both a nonlinearity and a displacement of the ratio vs. position function. This error can be made negligible by making $C_{D1}/C_D \geq 50$. C_{D1} is the decoupling capacitance for the sum signal in Figs. 1(c) and (d). It is interesting that the differential configuration in Fig. 1(b) is insensitive to such errors due to its symmetry.

A new circuit configuration for very large two

dimensional ("area") detectors with large capacitance, large resistance, and therefore a high τ_D , is shown in Fig. 7. The intent of this configuration is to reduce the τ_D (i.e., the resolving time) and the noise with a single charge division readout. The resistive electrode is divided into N sections, each with resistance R_D/N and capacitance C_D/N . A charge sensitive, FET input preamplifier with a low input impedance is connected at the node of each section. The outputs of these preamplifiers weighted in arithmetic progression form the position signal, and weighted uniformly, the energy signal. Each section behaves as one independent diffusive electrode with total time constant τ_D/N^2 instead of τ_D . This system achieves considerable savings over subdivision of the detector with a separate entire readout system for each subdivision. It also prevents dead regions and ambiguities at the boundary of each separate readout since the position and charge signals are continuous over the whole position range. The noise is still determined by the total detector capacitance C_D/N^2 ; Eq. (16), for optimum filtering $\tau_F \approx \frac{1}{2} \tau_D/N^2$.

From this discussion, the most appropriate configurations for particular detectors are indicated. Capacitive decoupling can be realized with lowest noise with more elaborate preamplifiers and it is suitable for single wire detectors, two dimensional detectors with zig-zag cathodes, and detectors with several wires at or near ground potential. Capacitive decoupling in Fig. 1(d) is applicable to semiconductor detectors, but it is rarely applicable to proportional detectors, since the opposite electrode (cathode) may not be accessible for signal extraction. Transformer coupling in Fig. 1(c) is suitable for large scale production of readouts for many wires, and for anodes as resistive electrodes at a high potential. The transformer configuration in Fig. 1(b) is the best with respect to various second order nonlinearity effects. However, the position signal of both polarities, Eq. (8), has to be processed (digitized). Alternatively, signal proportional to the sum signal Q_1+Q_2 has to be added to the position signal Q_2-Q_1 after filtering and stretching.

We have used all these configurations, except the one in Fig. 7, in practical detector systems. Some of these are described in Refs. 13, 17, and 18. In all proportional counters stainless steel (or nickel-chromium) wires were used as resistive electrodes.

The discussion in this paper points to desirable parameters for the resistive electrode in cases where these are under control. The lower limit for τ_D is determined by the charge collection time in the detector. The charge division method is insensitive to charge collection time variations, and the charge collection time can be longer than τ_D and/or τ_F while preserving the position signal linearity. The only consequence is a smaller signal in relation to the noise, and thus poorer position resolution. For the case where τ_D is shorter than the charge collection time, τ_F can be increased from the optimum value for an impulse signal to improve the position resolution. An optimum for this case is achieved if the electrode resistance R_D is increased until τ_D equals approximately $2\tau_F$.

For a given electrode capacitance C_D , the resistance R_D should be reduced until $\tau_D/2$ is approximately equal to the detector charge collection time (or to a value obtained for a particular signal current waveform, as shown in the preceding section). This is in order to achieve also the shortest resolving time (higher event rates), better energy resolution, and smaller timing walk.

The detector capacitance C_D should be as small as possible, as with any other charge collecting detector.

References

1. K. Louterjung, J. Pokar, B. Schimmer, and R. Stäudner, Nucl. Instr. and Meth. 22 (1963) 117.
2. G. Charpak, J. Favier, and L. Massonnet, Nucl. Instr. and Meth. 24 (1963) 501.
3. W. Schottky, Phys. Z., 31 (1930) 913.
4. C. J. Borkowski and M. K. Kopp, Rev. Sci. Instr. 39 (1968) 1515.
5. R. S. Owen and M. L. Awcock, IEEE Trans. Nucl. Sci. NS-15 (1968) 290.
6. S. Kalbitzer and W. Melzer, Nucl. Instr. and Meth. 56 (1967) 301.
7. S. Kalbitzer and W. Stumpfi, Nucl. Instr. and Meth. 77 (1970) 300.
8. J. R. Gigante, Nucl. Instr. and Meth. 111 (1973) 345.
9. C. J. Borkowski and M. K. Kopp, Rev. Sci. Instr. 46 (1975) 951.
10. G. L. Miller, N. Williams, A. Senator, R. Stensgaard, and J. Fischer, Nucl. Instr. and Meth. 91 (1971) 389.
11. H. W. Fulbright, R. G. Markham, and W. A. Lanford, Nucl. Instr. and Meth. 108 (1973) 125.
12. J. Nough and R. W. P. Drewer, Nucl. Instr. and Meth. 103 (1972) 365.
13. J. Alberi, J. Fischer, V. Radeka, L. C. Rogers, and B. Schoenborn, Nucl. Instr. and Meth. 127 (1975) 507.
14. W. M. Augustyniak, W. L. Brown, and H. P. Lie, IEEE Trans. Nucl. Sci. NS-19, No. 3 (1972) 196.
15. W. Parkes, K. D. Evans, and E. Mathieson, Nucl. Instr. and Meth. 121 (1974) 151.
16. H. Foeth, R. Hammarström, and C. Rubbia, Nucl. Instr. and Meth. 109 (1973) 521.
17. P. Schübelin, J. Fuhrmann, S. Iwata, V. Radeka, W. N. Schreiner, F. Turkot, R. W. Sancton, and A. Weitsch, "Low Mass Multiwire Proportional Chamber with Unambiguous Dual Coordinate Readout", submitted to Nucl. Instr. and Meth.
18. J. Fischer, J. Fuhrmann, S. Iwata, R. Palmer, and V. Radeka, "Large Proportional Multiwire Chambers for Transition Radiation Detection with Unambiguous Position Readout", submitted to Nucl. Instr. and Meth.
19. H. J. Woltring, IEEE Trans. on Electron Devices, ED-22 (1975) 581.
20. E. Mathieson, Nucl. Instr. and Meth. 92 (1971) 441.
21. E. Mathieson, K. D. Evans, W. Parkes, and P. F. Christie, Nucl. Instr. and Meth. 121 (1974) 139.
22. A. Doehring, S. Kalbitzer, and W. Melzer, Nucl. Instr. and Meth. 59 (1968) 40.
23. V. Radeka, IEEE Trans. Nucl. Sci., 21 (Feb. 1974) 51.
24. G. L. Miller and A. Senator, Proc. ISRA Symp. Nucl. Electronics, Italy, 6-9 May 1969, (EURATOM, Brussels, 1969, p. 217).
25. H. Becker, S. Kalbitzer, D. Rieck, and C. A. Wiedner, Nucl. Instr. and Meth. 95 (1971) 525.

Figure Captions

1. Charge division input circuit configurations.
 - (a) capacitive decoupling at both ends of the resistive electrode. The sum Q_1+Q_2 has to be formed externally.
 - (b) transformer decoupling. The difference Q_1-Q_2 is formed accurately by the transformer, and the sum Q_1+Q_2 by the lower amplifier.
 - (c) transformer decoupling. The sum Q_1+Q_2 is formed accurately by the lower amplifier.
 - (d) capacitive decoupling at one end of the resistive electrode. The sum Q_1+Q_2 is obtained as the total signal on the opposite electrode of the detector.

2. The position signals A and A-B, at the output of the filter amplifier, as functions of the position X and the weighting function width τ_F/τ_D . τ_D is the resistive electrode RC product.

3. The position error parameter k, Eqs. (9), (10) and (11) as a function of the weighting function width τ_F/τ_D .

4. Nonlinearity, i.e., fractional position error as a function of position. k vs τ_F/τ_D can be obtained from Fig. 3.

5. The effect of large noise in the charge (energy) signal. Upper half of the position scale is shown for $q_{A+B}^2 = \frac{1}{4} q_A^2$. All peaks have equal area.

6. Normalized spatial resolution vs shaping parameter τ_F/τ_R for a signal current waveform $i_{in} = \frac{Q_s}{\tau_R} e^{-t/\tau_R}$.

7. Multipreamplifier configuration with single charge division readout. The effective resistive electrode time constant is reduced from τ_F to τ_F/N^2 , and the mean square position noise is reduced by N^2 .

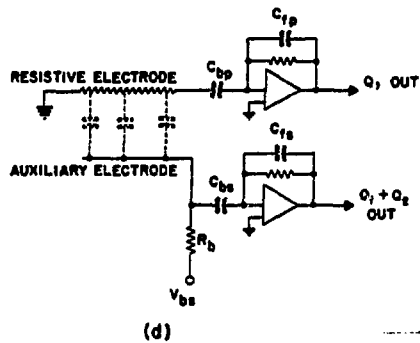
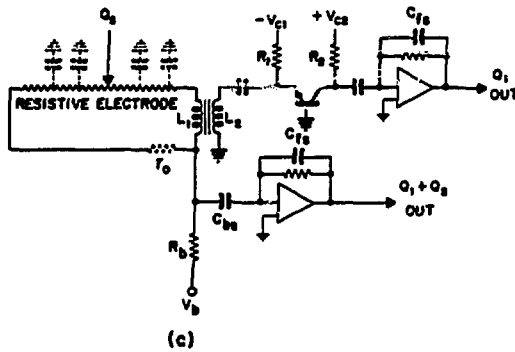
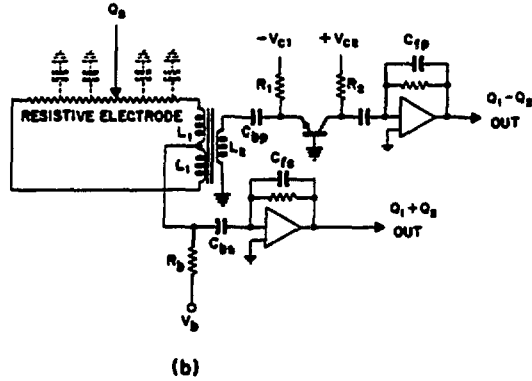
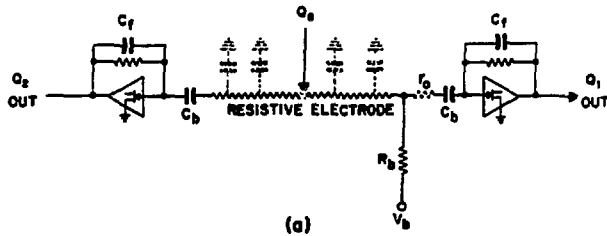

FIGURE 1

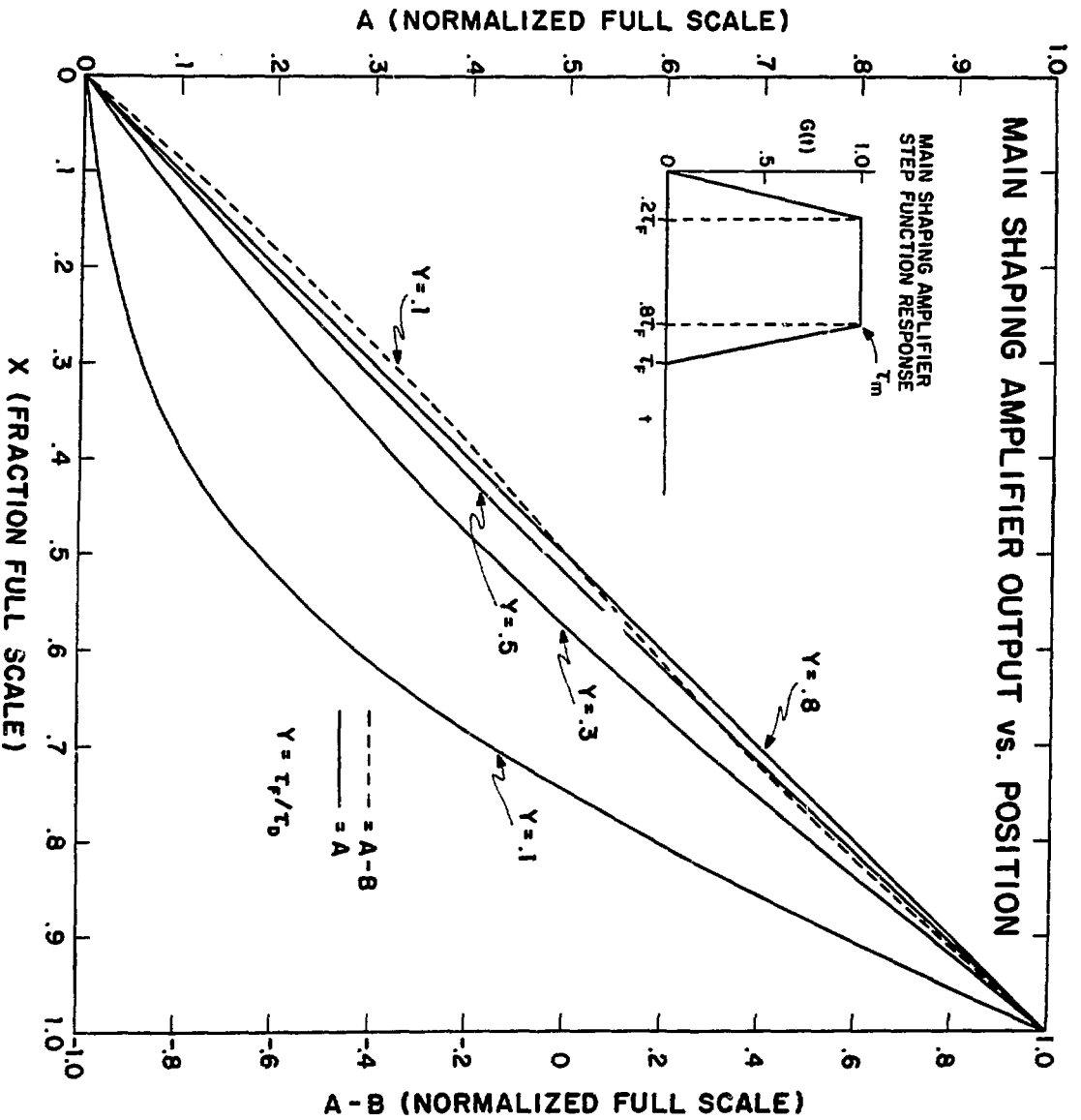

FIGURE 2

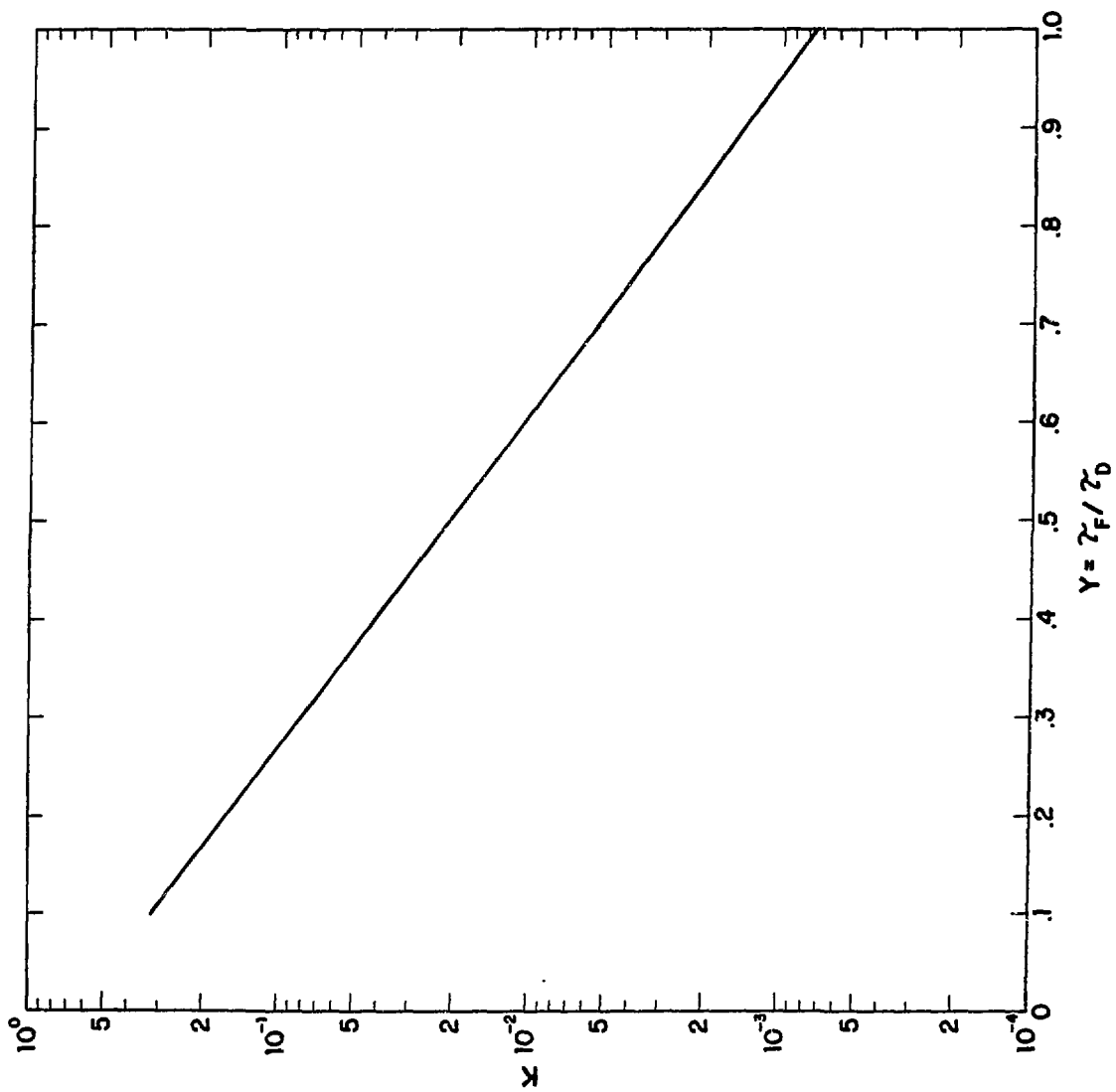

FIGURE 3

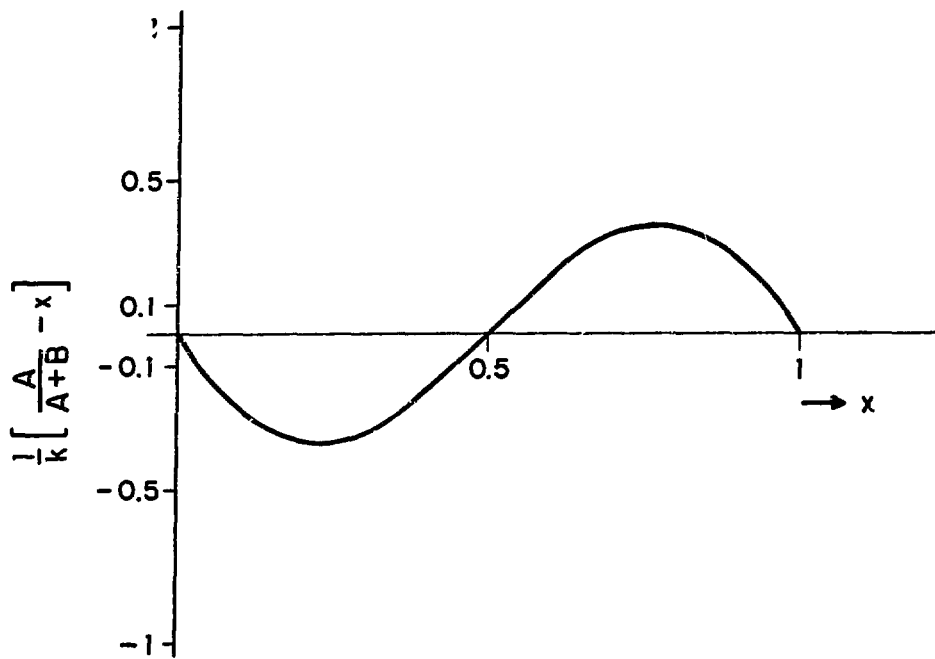

FIGURE 4

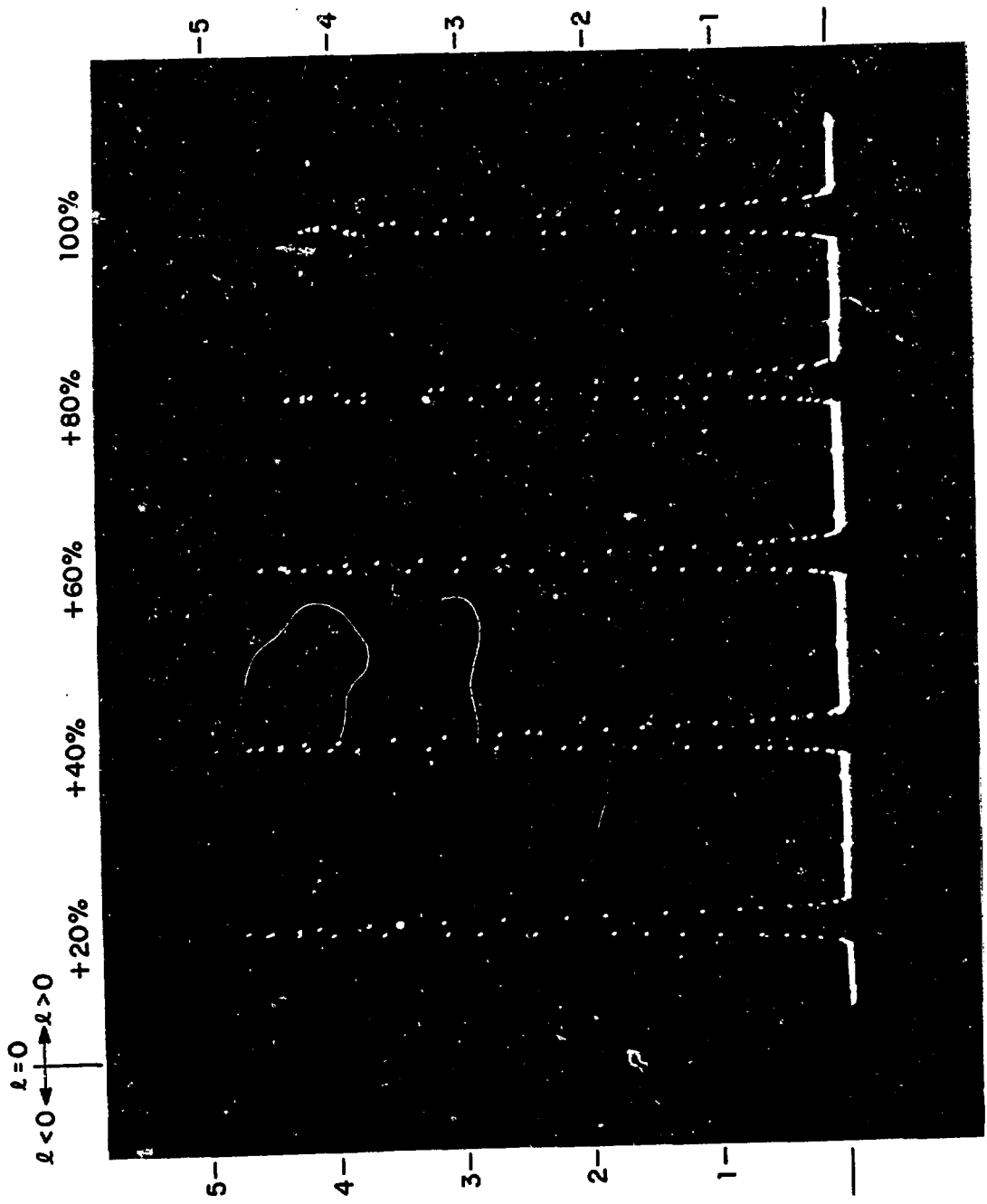

FIGURE 5

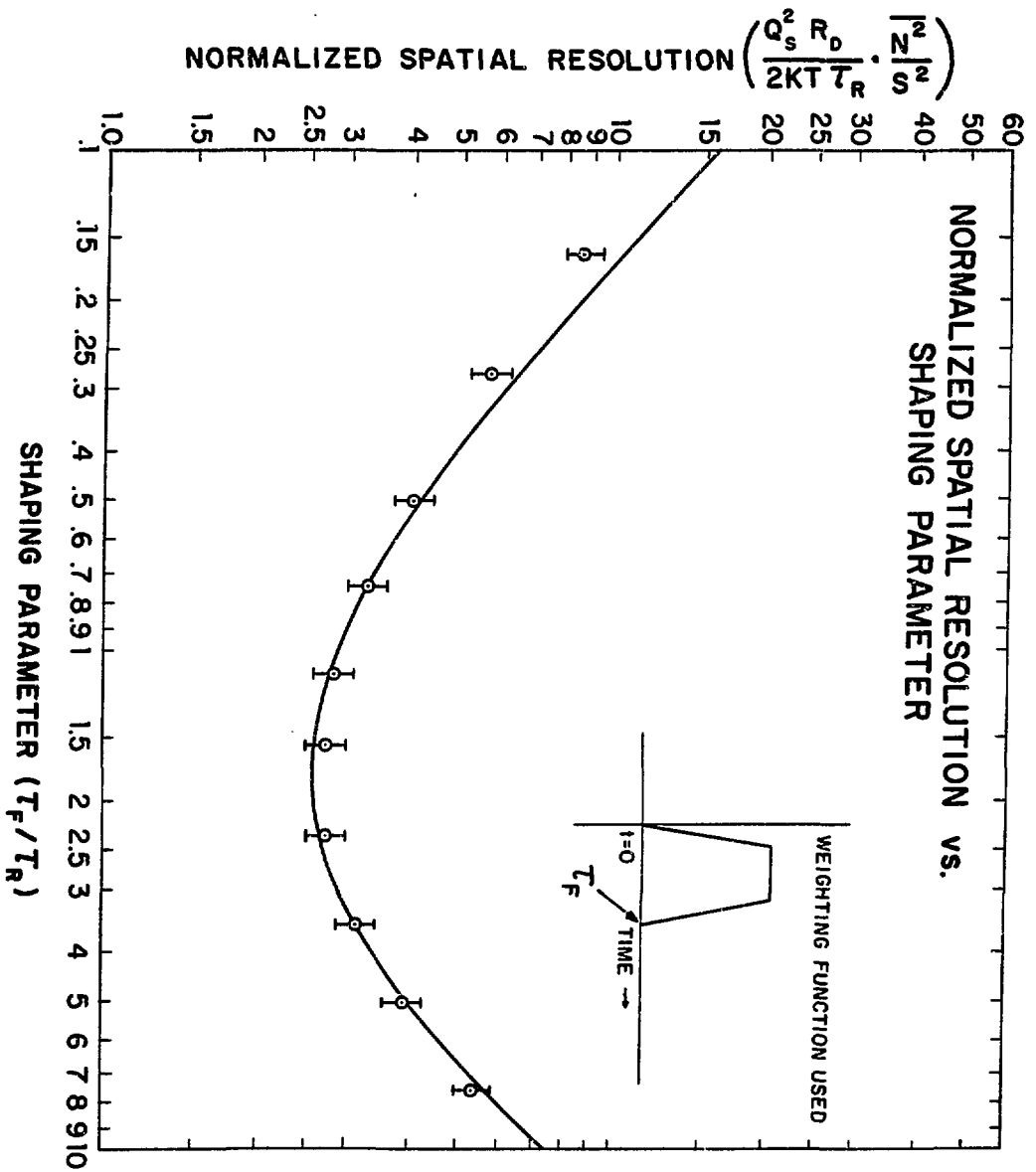

FIGURE 6

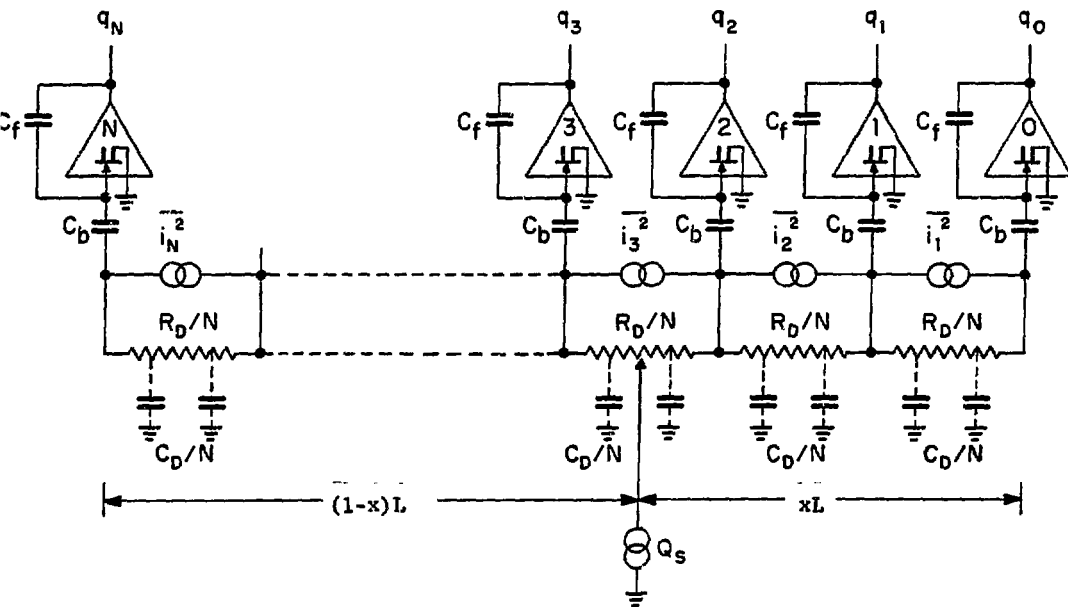
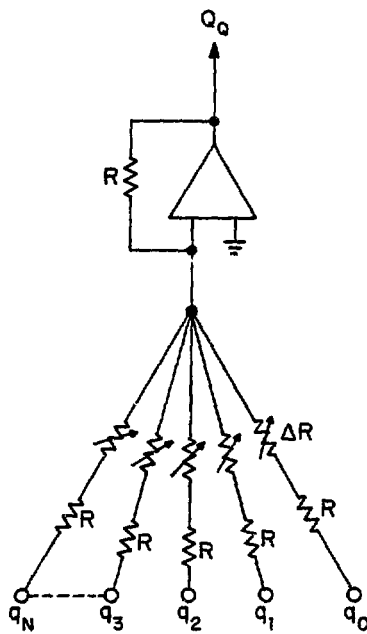
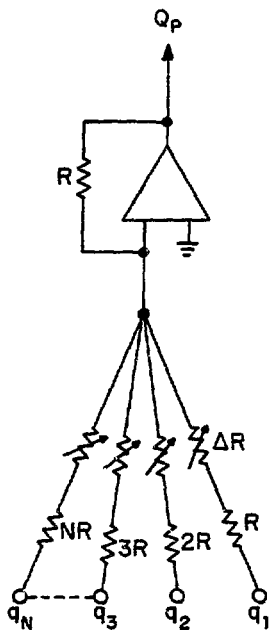

FIGURE 7