

Positron Emission Tomography Compartmental Models

Roger N. Gunn[†], Steve R. Gunn[‡], and Vincent J. Cunningham[§]

[†]McConnell Brain Imaging Center, Montreal Neurological Institute,
McGill University, Montreal, Canada

[‡]Image, Speech and Intelligent Systems Research Group,
University of Southampton, U.K.

[§]Imaging Research Solutions Ltd., Cyclotron Building,
Hammersmith Hospital, London, U.K.

JCBFM 21(6):635-652, 2001

Roger N. Gunn, Ph.D.
McConnell Brain Imaging Center
Montreal Neurological Institute
3801 University St
Montreal, QC
CANADA, H3A 2B4
Email: rgunn@bic.mni.mcgill.ca
Tel: (001) 514 398 8841
Fax: (001) 514 398 8766

Abstract

This paper presents theory for compartmental models used in positron emission tomography. Both plasma input models and reference tissue input models are considered. General theory is derived and the systems are characterised in terms of their impulse response functions. The theory shows that the macro parameters of the system may be determined simply from the coefficients of the impulse response functions. These results are discussed in the context of radioligand binding studies. It is shown that binding potential is simply related to the integral of the impulse response functions for all plasma and reference tissue input models currently used in positron emission tomography. The paper also introduces a general compartmental description for the behaviour of the tracer in blood, which then allows for the blood volume induced bias in reference tissue input models to be assessed.

Keywords: *PET, Tracer Kinetics, Compartmental Modelling, Parameter Estimation, Basis Pursuit Denoising, Sparse Basis Selection*

1 Introduction

Compartmental analysis forms the basis for tracer kinetic modeling in Positron Emission Tomography (PET). Well established compartmental models in PET include those used for the quantification of blood flow (Kety and Schmidt, 1948), cerebral metabolic rate for glucose (Sokoloff et al., 1977; Phelps et al., 1979) and for neuroreceptor ligand binding (Mintun et al., 1984). These particular models require an arterial blood or plasma input function, with the number of tissue compartments dictated by the physiological, biochemical and physiological properties of the system under study. Other 'reference tissue models' have been developed, particularly for the study of neuroreceptor ligands (Blomqvist et al., 1989; Cunningham et al., 1991; Hume et al., 1992; Lammertsma et al., 1996; Lammertsma and Hume, 1996; Gunn et al., 1997; Watabe et al., 2000), with a view to avoiding blood sampling. These enable the target tissue time activity curve to be expressed as a function of that of the reference tissue. For neuroreceptor applications reference tissue models assume that there exists a reference area of brain tissue essentially devoid of specific binding sites. The number of compartments in the reference region and in the region of interest is dependent on the rate of exchange of the tracer between the free, nonspecifically bound and specifically bound pools of tracer. All these models make a series of general assumptions, e.g. that there is instantaneous mixing within the individual compartments, and that the concentration of tracer is small enough such that it does not perturb the system under study. Under these conditions the systems are described by a set of first order linear differential equations. Parameter estimates may be obtained by the weighted least squares fitting of these models to measured PET data. This paper is not concerned with the determination of model complexity from measured data, but with the analysis of those model configurations which have been selected a priori by the investigator.

In PET the measured regional radioactivity comprises the sum of all tissue compartments and a blood volume component. As Schmidt (1999) comments 'most of the literature on compartmental systems has been concerned with measurement of the content of individual compartments, and little attention has been directed to the particular problem of characterising the sum of the contents in all compartments of the system'. This paper is principally concerned with developing a general framework for PET compartmental models. It aims to draw attention to the parallels which exist between reference tissue models and those models employing a plasma input, and to those properties of reference tissue models which are robust and common to all models independent of the number and topology of compartments used to describe the tissues. Both reversible and irreversible systems will be considered and particular attention will be paid to their interpretation in terms of neuroreceptor ligand binding studies.

The paper presents general theory for modelling of tissue data using either a plasma input (Section 2) or a reference tissue input (Section 3). Theory is also presented for the behaviour of the tracer in blood which accounts for both partitioning and metabolism (Appendix A). This enables theoretical consideration of blood activity contribution to the tissue signals for reference tissue input models. General theory is derived which gives the explicit functional form for the impulse response functions of the systems. It will be seen that simple relationships

exist between these functional forms and the macro system parameters. First, some of the basic concepts used in the paper are introduced:

Linear Compartmental Systems

Linear compartmental systems lead to a set of linear first order differential equations. Often in PET articles these equations are written out explicitly. However, it is convenient and concise to represent the whole system in terms of state space representation. A time-invariant linear compartmental system is defined in terms of its state space representation as,

$$\begin{aligned}\dot{\mathbf{x}}(t) &= \mathbf{A}\mathbf{x}(t) + \mathbf{B}\mathbf{u}(t), \\ \mathbf{y}(t) &= \mathbf{C}\mathbf{x}(t) + \mathbf{D}\mathbf{u}(t), \\ \mathbf{x}(0) &= \mathbf{x}_0.\end{aligned}\tag{1}$$

where $\mathbf{x}(t)$ is a p -vector of state variables, $\mathbf{y}(t)$ is a q -vector of observations, $\mathbf{u}(t)$ is a r -vector of input functions, \mathbf{A} is the $(p \times p)$ state transition matrix, \mathbf{B} is the $(p \times r)$ input matrix, \mathbf{C} is the $(q \times p)$ observation matrix, \mathbf{D} is the $(q \times r)$ feedthrough matrix, and \mathbf{x}_0 is a p -vector of initial conditions. The state transition matrix \mathbf{A} takes the form of a diagonally dominant matrix with non-positive diagonal elements and non-negative off diagonal elements. In this paper the non-cyclic subset of linear compartmental systems is considered, which implies that \mathbf{A} is negative semidefinite (for a discussion of these issues see Schmidt (1999)). The elements of \mathbf{A} , \mathbf{B} , \mathbf{C} and \mathbf{D} are assumed to be constant during the period of the experiment, although they may change between experiments. In PET \mathbf{A} is made up of simple combinations of the rate constants denoting the transfer of material between compartments, \mathbf{B} is typically just the delivery of the tracer to the tissue, K_1 , \mathbf{C} is a vector of 1's which implies that the observation is the sum of all the compartments, and \mathbf{D} contains the blood volume fraction, V_B . The input, $\mathbf{u}(t)$, contains the plasma parent and whole blood time courses, and the observation (or output), $\mathbf{y}(t)$, corresponds to the tomographic PET signal.

Macro and Micro Parameters

In this paper the terms macro and micro parameters are used to distinguish between the individual rate constants (micro) and global system parameters which are functions of the rate constants (macro). For instance, the volume of distribution of the target tissue, V_D , which is equal to the step response of the system, and the irreversible uptake rate constant from plasma, K_I , which is equal to the steady state response of the system are both macro parameters. The macro parameters are generally more stable with respect to the parameter estimation problem from dynamic PET data.

Indistinguishability and Identifiability

Within the paper the concepts of indistinguishability and identifiability of the linear compartmental systems are discussed. Indistinguishability is concerned with determining a set of models which give rise to identical input-output behaviour. Structural identifiability is concerned with whether or not the parameters may be estimated uniquely from perfect input-output data. This may be determined from analysis of the transfer function using a technique such as the Laplace transform approach ([Godfrey, 1983](#)).

2 Plasma Input Models

Consider a general PET system, as illustrated in Figure 1 where the measured radioactivity data consists of the total tissue concentration, C_T , the parent tracer concentration in plasma, C_P , and the whole blood concentration, C_B . The blood volume component is omitted from Figure (1) for clarity.

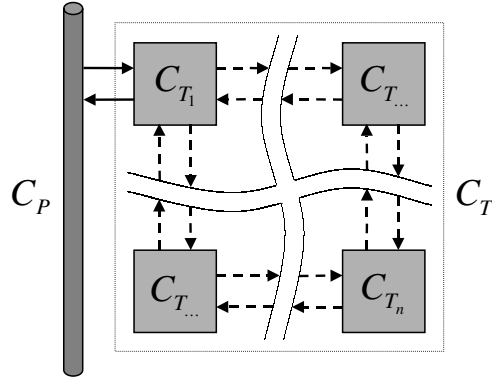

FIGURE 1: Generalised tissue model

Its state space formulation is given by

$$\begin{aligned}
 \dot{\mathbf{C}}_{\mathbf{T}}(t) &= \mathbf{A}\mathbf{C}_{\mathbf{T}}(t) + [K_1\mathbf{e}_1 \quad \mathbf{0}] \begin{bmatrix} C_P(t) \\ C_B(t) \end{bmatrix} \\
 C_T(t) &= (1 - V_B)\mathbf{1}^T\mathbf{C}_{\mathbf{T}}(t) + [0 \quad V_B] \begin{bmatrix} C_P(t) \\ C_B(t) \end{bmatrix} \\
 \mathbf{C}_{\mathbf{T}}(0) &= \mathbf{0}.
 \end{aligned} \tag{2}$$

where \mathbf{A} is the state transition matrix, K_1 is the influx constant for tracer into the tissue, and V_B is the fractional blood volume component.

Definition 2.1. Let \mathcal{M} denote the set of linear compartmental systems with n compartments (described by equation 2), where \mathbf{A} is negative semidefinite¹ with distinct eigenvalues,

$$\mathcal{M} = \left\{ (\mathbf{A}, K_1, V_B) \left| \begin{array}{l} \mathbf{A}_{ij} \geq 0, \mathbf{A}_{ii} \leq 0, \sum_i \mathbf{A}_{ij} \leq 0, \forall_{\mathbf{x}} \mathbf{x}^T \mathbf{A} \mathbf{x} \leq 0 \\ K_1 \geq 0, V_B \in [0, 1], |\text{Sp}(\mathbf{A})| = n \end{array} \right. \right\}.$$

Let \mathcal{R} denote the set of reversible models (Figure 2),

$$\mathcal{R} = \{ \mathcal{M} \mid \forall_j \exists_i : \mathbf{A}_{ij} \neq 0 \} \subset \mathcal{M},$$

¹This set includes all non-cyclic systems and the subset of cyclic systems in which the product of rate constants is the same regardless of direction for every cycle (Goldberg, 1956; Godfrey, 1983)

and \mathcal{I} denote the set of irreversible models with a single trap² (Figure 3),

$$\mathcal{I} = \{\mathcal{M} \mid \forall_i \mathbf{A}_{in} = 0\} \subset \mathcal{M}.$$

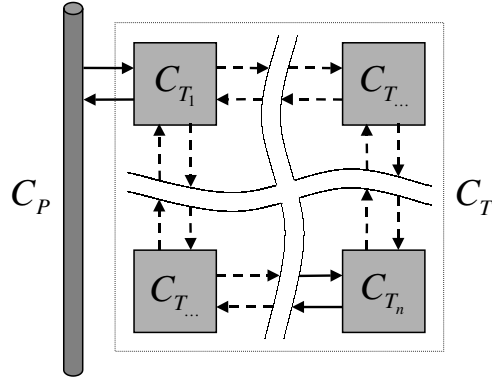

FIGURE 2: Reversible tissue model

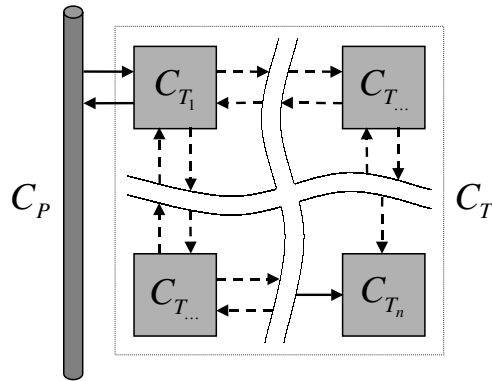

FIGURE 3: Irreversible tissue model with a single trap

Theorem 2.2. A model $s \in \mathcal{M}$ has a solution given by,

$$C_T(t) = (1 - V_B)H_{TP}(t) \otimes C_P(t) + V_B C_B(t),$$

where

$$H_{TP}(t) = \begin{cases} \sum_{i=1}^n \phi_i e^{-\theta_i t} & : s \in \mathcal{R} \\ \sum_{i=1}^{n-1} \phi_i e^{-\theta_i t} + \phi_n & : s \in \mathcal{I} \end{cases},$$

$$\theta_i > 0 \text{ and } \sum_{i=1}^n \phi_i = K_1.$$

²Without loss of generality the n th compartment is defined to be the trap

If $s \in \mathcal{R}$,

$$\begin{aligned} \sum_{i=1}^n \frac{\phi_i}{\theta_i} &= \int_0^{\infty} H_{TP}(t) dt, \\ &= V_D. \end{aligned}$$

If $s \in \mathcal{I}$,

$$\begin{aligned} \phi_n &= \lim_{t \rightarrow \infty} H_{TP}(t), \\ &= K_I. \end{aligned}$$

It is straightforward to derive an indistinguishability and identifiability corollary directly from Theorem 2.2.

Corollary 2.3. *Indistinguishability: Any two plasma input models within the subset \mathcal{R} (or similarly for \mathcal{I}) with a total of N tissue compartments are indistinguishable.*

Corollary 2.4. *Identifiability: The macro parameters (K_1 , V_D or K_I) are uniquely identifiable from perfect input-output data.*

3 Reference Tissue Input Models

Consider a general PET reference compartmental system, as illustrated in Figure 4 where the measured radioactivity data consists of the total tissue concentration, C_T , and the total reference tissue concentration, C_R . The general PET reference tissue model restricts the interaction of the target and reference tissues solely via the plasma.

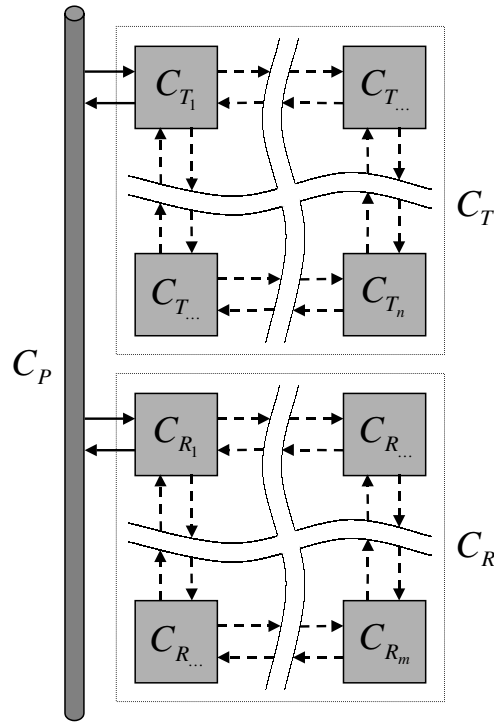

FIGURE 4: Generalised reference tissue model

Its state space formulation is given by,

$$\begin{aligned}
 \begin{bmatrix} \dot{\mathbf{C}}_{\mathbf{T}}(t) \\ \dot{\mathbf{C}}_{\mathbf{R}}(t) \end{bmatrix} &= \begin{bmatrix} \mathbf{A} & \mathbf{0} \\ \mathbf{0} & \mathbf{A}' \end{bmatrix} \begin{bmatrix} \mathbf{C}_{\mathbf{T}}(t) \\ \mathbf{C}_{\mathbf{R}}(t) \end{bmatrix} + \begin{bmatrix} K_1 \mathbf{e}_1 & \mathbf{0} \\ K'_1 \mathbf{e}_1 & \mathbf{0} \end{bmatrix} \begin{bmatrix} C_P(t) \\ C_B(t) \end{bmatrix} \\
 \begin{bmatrix} C_T(t) \\ C_R(t) \end{bmatrix} &= \begin{bmatrix} (1 - V_B) \mathbf{1}^T & \mathbf{0}^T \\ \mathbf{0}^T & (1 - V'_B) \mathbf{1}^T \end{bmatrix} \begin{bmatrix} \mathbf{C}_{\mathbf{T}}(t) \\ \mathbf{C}_{\mathbf{R}}(t) \end{bmatrix} + \begin{bmatrix} 0 & V_B \\ 0 & V'_B \end{bmatrix} \begin{bmatrix} C_P(t) \\ C_B(t) \end{bmatrix} \\
 \begin{bmatrix} \mathbf{C}_{\mathbf{T}}(0) \\ \mathbf{C}_{\mathbf{R}}(0) \end{bmatrix} &= \mathbf{0}.
 \end{aligned} \tag{3}$$

where the primes (') refer to the reference tissue parameters. Often when a reference tissue model is used there is no associated measurement of the blood radioactivity concentration and so correction for blood contribution to the tissue signals is not possible. Here, the cases when the blood activity does and does not contribute to the tissue signals are considered separately.

No Blood Volume

Consider the case where there is no contribution of blood activity to the reference and target tissue signals ($V_B = V'_B = 0$).

Definition 3.1. Consider the set of linear compartmental reference systems (described by equation 3) where the connection of the reference tissue (m compartments) and the target tissue (n compartments) is solely through the plasma and the blood volume components are zero,

$$\mathcal{F} = \left\{ (s', s) \mid \begin{array}{l} s' \in \mathcal{M}, V'_B = 0, s \in \mathcal{M}, V_B = 0, \\ |Sp(\mathbf{A}) \cup Sz(\mathbf{A}', \mathbf{b}')| = n + m - 1 \end{array} \right\}.$$

The set of reversible reference, reversible target models (Figure 5) is defined as,

$$\mathcal{F}_{\mathcal{R}\mathcal{R}} = \{(s', s) \mid s' \in \mathcal{R}, s \in \mathcal{R}\} \cap \mathcal{F}.$$

The set of reversible reference, irreversible target models (Figure 6) is defined as,

$$\mathcal{F}_{\mathcal{R}\mathcal{I}} = \{(s', s) \mid s' \in \mathcal{R}, s \in \mathcal{I}\} \cap \mathcal{F}.$$

The set of irreversible reference, irreversible target models (Figure 7) is defined as,

$$\mathcal{F}_{\mathcal{I}\mathcal{I}} = \{(s', s) \mid s' \in \mathcal{I}, s \in \mathcal{I}\} \cap \mathcal{F}.$$

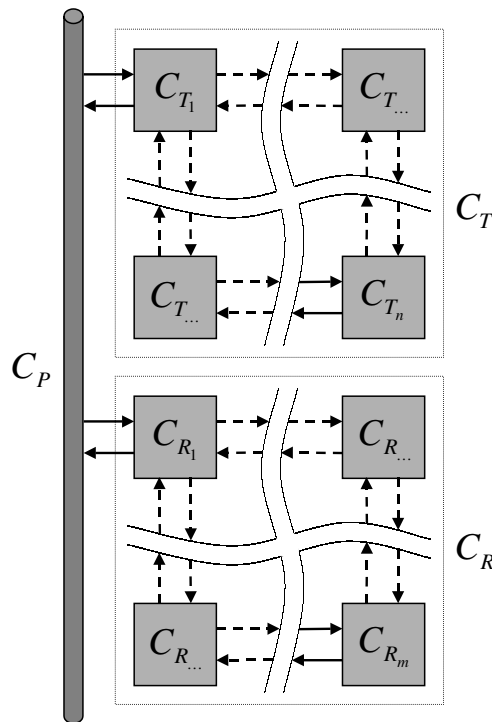

FIGURE 5: Reference tissue model with reversible target and reference tissues

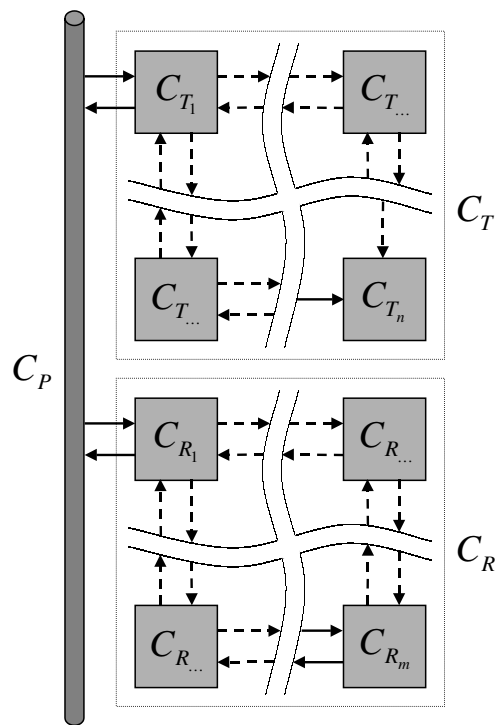

FIGURE 6: Reference tissue model with irreversible target tissue and reversible reference tissue

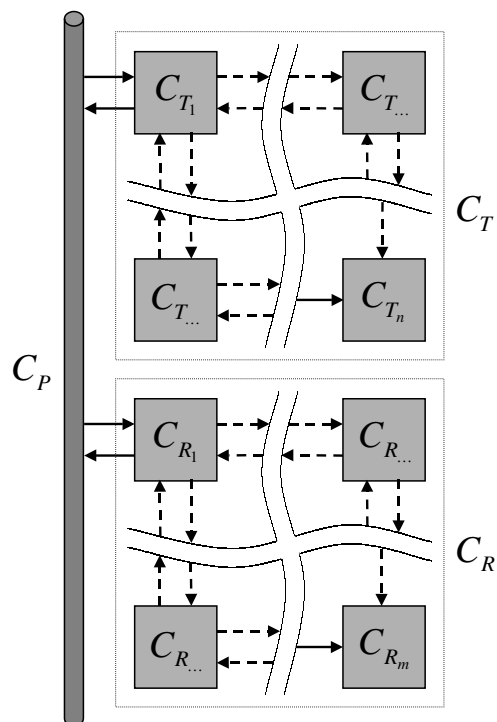

FIGURE 7: Reference tissue model with irreversible target and reference tissues (single trap in each)

Theorem 3.2. *A model $s \in \mathcal{F}$ has a solution given by,*

$$C_T(t) = H_{TR}(t) \otimes C_R(t),$$

where

$$H_{TR}(t) = \begin{cases} \phi_0 \delta(t) + \sum_{i=1}^{m+n-1} \phi_i e^{-\theta_i t} & : s \in \mathcal{F}_{RR} \\ \phi_0 \delta(t) + \sum_{i=1}^{m+n-2} \phi_i e^{-\theta_i t} + \phi_{m+n-1} & : s \in \mathcal{F}_{RI} \\ \phi_0 \delta(t) + \sum_{i=1}^{m+n-2} \phi_i e^{-\theta_i t} & : s \in \mathcal{F}_{II} \end{cases},$$

$$\theta_i > 0 \text{ and } \phi_0 = \frac{K_1}{K'_1} = R_I.$$

If $s \in \mathcal{F}_{RR}$,

$$\begin{aligned} \phi_0 + \sum_{i=1}^{m+n-1} \frac{\phi_i}{\theta_i} &= \int_0^{\infty} H_{TR}(t) dt, \\ &= \frac{V_D}{V'_D}. \end{aligned}$$

If $s \in \mathcal{F}_{RI}$,

$$\begin{aligned} \phi_{m+n-1} &= \lim_{t \rightarrow \infty} H_{TR}(t), \\ &= \frac{K_I}{V'_D}. \end{aligned}$$

If $s \in \mathcal{F}_{II}$,

$$\begin{aligned} \phi_0 + \sum_{i=1}^{m+n-2} \frac{\phi_i}{\theta_i} &= \int_0^{\infty} H_{TR}(t) dt, \\ &= \frac{K_I}{K'_I}. \end{aligned}$$

Again, it is straightforward to derive an indistinguishability and identifiability corollary directly from Theorem 3.2.

Corollary 3.3. *Indistinguishability: Any two reference tissue input models within the subset \mathcal{F}_{RR} (or similarly for \mathcal{F}_{RI} or \mathcal{F}_{II}) with a total of N tissue compartments (reference+target) are indistinguishable.*

Corollary 3.4. *Identifiability: The macro parameters (R_I , $\frac{V_D}{V'_D}$ or $\frac{K_I}{V'_D}$ or $\frac{K_I}{K'_I}$) are uniquely identifiable from perfect input-output data.*

Blood Volume

Now consider the general PET reference tissue model, Figure 4, with blood volume in both the reference and target tissues ($V_B > 0, V'_B > 0$). The subsequent Theorem requires characterisation of the tracer's behaviour in blood and uses a result derived in Appendix A (Lemma A.1).

Definition 3.5. Consider the set of linear compartmental reference systems (described by equation 3) where the connection of the reference tissue (m compartments) and the target tissue (n compartments) is solely through the plasma, a blood volume component is present in each tissue and the tracer behaviour in blood is described by Lemma A.1 (see Appendix B),

$$\mathcal{G} = \left\{ (s', s) \mid \begin{array}{l} s' \in \mathcal{M}, V'_B > 0, s \in \mathcal{M}, V_B > 0, \\ |Sp(\mathbf{A}) \cup \Omega| = n + m + p + q - 1 \end{array} \right\}.$$

The set of reversible reference, reversible target models (Figure 5) is defined as,

$$\mathcal{G}_{\mathcal{R}\mathcal{R}} = \{(s', s) \mid s' \in \mathcal{R}, s \in \mathcal{R}\} \cap \mathcal{G}.$$

The set of reversible reference, irreversible target models (Figure 6) is defined as,

$$\mathcal{G}_{\mathcal{R}\mathcal{I}} = \{(s', s) \mid s' \in \mathcal{R}, s \in \mathcal{I}\} \cap \mathcal{G}.$$

The set of irreversible reference, irreversible target models (Figure 7) is defined as,

$$\mathcal{G}_{\mathcal{I}\mathcal{I}} = \{(s', s) \mid s' \in \mathcal{I}, s \in \mathcal{I}\} \cap \mathcal{G}.$$

Theorem 3.6. A model $s \in \mathcal{G}$ has a solution given by,

$$C_T(t) = H_{TR}(t) \otimes C_R(t),$$

where

$$H_{TR}(t) = \begin{cases} \phi_0 \delta(t) + \sum_{i=1}^{m+n+p+q-1} \phi_i e^{-\theta_i t} & : s \in \mathcal{G}_{\mathcal{R}\mathcal{R}} \\ \phi_0 \delta(t) + \sum_{i=1}^{m+n+p+q-2} \phi_i e^{-\theta_i t} + \phi_{m+n+p+q-1} & : s \in \mathcal{G}_{\mathcal{R}\mathcal{I}} \\ \phi_0 \delta(t) + \sum_{i=1}^{m+n+p+q-2} \phi_i e^{-\theta_i t} & : s \in \mathcal{G}_{\mathcal{I}\mathcal{I}} \end{cases},$$

$$\theta_i \geq 0 \text{ and } \phi_0 = \frac{V_B}{V'_B}.$$

If $s \in \mathcal{G}_{RR}$,

$$\begin{aligned} \phi_0 + \sum_{i=1}^{m+n+p+q-1} \frac{\phi_i}{\theta_i} &= \int_0^{\infty} H_{TR}(t) dt \\ &= \frac{(1 - V_B) V_D + V_B P_B}{(1 - V'_B) V'_D + V'_B P_B}. \end{aligned}$$

If $s \in \mathcal{G}_{RL}$,

$$\begin{aligned} \phi_{m+n+p+q-1} &= \lim_{t \rightarrow \infty} H_{TR}(t) \\ &= \frac{(1 - V_B) K_I}{(1 - V'_B) V'_D + V'_B P_B}. \end{aligned}$$

If $s \in \mathcal{G}_{IL}$,

$$\begin{aligned} \phi_0 + \sum_{i=1}^{m+n+p+q-2} \frac{\phi_i}{\theta_i} &= \int_0^{\infty} H_{TR}(t) dt, \\ &= \frac{(1 - V_B) K_I}{(1 - V'_B) K'_I}. \end{aligned}$$

4 Discussion

This paper is concerned with generic compartmental modelling of dynamic PET data, where the measured signal is the sum of all the constituent tissue compartments. General results have been derived for plasma input and reference tissue input models and are summarised in Tables 1 and 2. In each case the tissue impulse response function is comprised of a sum of exponentials, with an additional delta function term for reference tissue input models. There are three fundamental characteristics of the tissue impulse response function that are of interest; the initial value (which is equal to the value at $t = 0$), the step response (which is equal to the area under the impulse response function from $t = 0$ to $t = \infty$) and the steady state response (which is equal to the final value of the impulse response function). It can be seen that macro parameters of the system (V_D , K_I , $\frac{V_D}{V'_D}$, $\frac{K_I}{K'_I}$, $\frac{K_I}{K'_I}$, $BP.f_1$, and $BP.f_2$) are simply related to these characteristics of the impulse response function independent of the number and topology of compartments. Furthermore, these macro parameters are uniquely identifiable from perfect input-output data.

Plasma Input Models

Plasma input models in PET are often treated as a gold standard (Kety and Schmidt, 1948; Sokoloff et al., 1977; Phelps et al., 1979; Mintun et al., 1984). The impulse response function is a sum of exponentials (Theorem 2.2), with the rate of delivery from the plasma, K_1 , given by the initial value of the impulse response function. For reversible tissue kinetics the total volume of distribution, V_D , is given by the integral of the impulse response function. For irreversible tissue kinetics the irreversible uptake rate constant from plasma, K_I , is given by the final value of the impulse response function. It may be noted that the final value of the impulse response function is equal to the limiting slope of a Patlak plot (Patlak et al., 1983). This result, as with the Patlak analysis, is independent of the number of intermediate reversible tissue compartments.

Target Tissue	Impulse Response	Parameter
\mathcal{R}	$\sum_{i=1}^n \phi_i e^{-\theta_i t}$	$V_D = \sum_{i=1}^n \frac{\phi_i}{\theta_i}$
\mathcal{I}	$\sum_{i=1}^{n-1} \phi_i e^{-\theta_i t} + \phi_n$	$K_I = \phi_n$

TABLE 1: Summary of Plasma Input Models

Reference Tissue Input Models

Reference tissue models have the advantage that no blood measurements are required and parameters are derived purely from the tomographic tissue data. For reference tissue input models the general form of the impulse response function is a sum of exponentials plus a delta function term (Theorem 3.2). First, consider the results when there is no significant blood volume contribution to either the target or reference tissue. The coefficient of the delta function is equal to the relative delivery of tracer to the target versus the reference tissue, R_I . For reversible kinetics in both the reference and the target tissues the integral of the impulse response function is equal to $\frac{V_D}{V'_D}$. The relationship of this parameter to $BP.f_2$ is discussed later. If the target tissue is irreversible and the reference tissue is reversible the normalised irreversible uptake rate constant from plasma, $\frac{K_I}{V'_D}$, is given by the final value of the impulse response function. Again this is analogous to the reference tissue Patlak approach (Patlak and Blasberg, 1985). If both the target and reference tissues are irreversible then the ratio of the uptake rate constants between the target and the reference, $\frac{K_I}{K'_I}$, is given by the integral of the impulse response function.

Tissue		Impulse Response	Parameter
Reference	Target		
\mathcal{R}	\mathcal{R}	$\phi_0\delta(t) + \sum_{i=1}^{m+n-1} \phi_i e^{-\theta_i t}$	$\frac{V_D}{V'_D} = \phi_0 + \sum_{i=1}^{m+n-1} \frac{\phi_i}{\theta_i}$
\mathcal{R}	\mathcal{I}	$\phi_0\delta(t) + \sum_{i=1}^{m+n-2} \phi_i e^{-\theta_i t} + \phi_n$	$\frac{K_I}{V'_D} = \phi_n$
\mathcal{I}	\mathcal{I}	$\phi_0\delta(t) + \sum_{i=1}^{m+n-2} \phi_i e^{-\theta_i t}$	$\frac{K_I}{K'_I} = \phi_0 + \sum_{i=1}^{m+n-2} \frac{\phi_i}{\theta_i}$

TABLE 2: Summary of Reference Tissue Input Models

For reference tissue input models it is interesting to note the similarities and equivalences with plasma input models. In particular, for reversible kinetics the integral of the impulse response function for plasma input models is the volume of distribution, V_D , and for reference tissue input models it is the relative volume of distribution, $\frac{V_D}{V'_D}$. Other similar analogies apply for the irreversible cases.

Model Indistinguishability

As a consequence of Theorem 3.2 it can be shown that the topology of the compartments in the reference and target tissues is not important as regards the macro parameters. It is merely the total number of compartments in the reference and target tissues that defines the set of indistinguishable reference tissue input models (Corollary 3.3). In practice the models may

behave slightly differently if there is a significant contribution of blood activity to the tissue signal.

Inclusion of Blood Volume

This paper also considers the case where a significant contribution to the tissue signals is derived from the blood. If this is the case then a bias may be introduced in the macro parameter estimates. The magnitude of this bias is dependent on the blood volume, V_B , the volume of distribution of the reference tissue, V'_D , and the steady state parent plasma to whole blood ratio, P_B (Theorem 3.6). Similarly, a bias in the macro parameters for plasma input models, when blood contribution is ignored, can also be derived (not shown here). Investigators should be aware of these factors when applying plasma/reference input compartmental models or graphical methods such as the Patlak (Patlak et al., 1983) and Logan (Logan et al., 1990) plots without correcting for blood volume.

Radioligand Binding Studies

Let us now consider these models in the context of radioligand binding studies. There are several compartmental models in common use for the analysis of radioligand binding (Appendix C.1 and C.2). The point of these appendices is to illustrate the relationship between these commonly used compartmental models and the general results derived in this paper. The models in the appendix are formulated in terms of micro parameters i.e. individual rate constants for the exchange of tracer between compartments. In particular they show that for reversible reference tissue models the integral of the impulse response function is simply related to binding potential in the same way in all cases.

Binding potential, BP , is a useful measure to quantify ligand-receptor interactions. The original definition of binding potential was introduced by Mintun (Mintun et al., 1984) as the ratio of B_{max} (the maximum concentration of available receptor sites) to the apparent K_D of the free radioligand. To determine this parameter the free fractions of the radioligand in plasma (f_1) and tissue (f_2) need to be taken into account (Koeppel et al., 1991). It is necessary to distinguish between estimates of BP , $BP.f_1$, and $BP.f_2$. A summary of these parameters and their relationship to the volumes of distribution is given in Table 3.

$BP.f_2$ may be determined from micro or macro parameters; Either directly from the ratio of the micro parameters (typically k_3 and k_4), or indirectly from a volume of distribution ratio. The direct estimation is often susceptible to noise and the $BP.f_2$ estimate may be unreliable. The second case requires a suitable reference region devoid of specific binding and requires that $V'_{DF} + V'_{DNS} = V_{DF} + V_{DNS}$ (this assumption might be assessed by separate blocking studies). The determination of $BP.f_1$ requires the same two assumptions, and is derived by subtracting the reference tissue volume of distribution from that of the target tissue. To derive the true binding potential, BP , the additional measure of the plasma free fraction is required,

f_1 . The measurement of f_1 may be determined from analysis of a blood sample, although these measurements are often inaccurate (see Laruelle (2000) for a discussion of these issues). These results are summarised in Table 3.

BP notation	V_3 notation	Definition	Calculation	Input required
BP	V_3	$\frac{B_{max}}{K_D \left(1 + \sum_i \frac{F_i}{K_{D_i}}\right)}$	$\frac{V_D - V'_D}{f_1}$	C_P
$BP.f_1$	V'_3	$\frac{f_1 B_{max}}{K_D \left(1 + \sum_i \frac{F_i}{K_{D_i}}\right)}$	$V_D - V'_D$	C_P
$BP.f_2$	V''_3	$\frac{f_2 B_{max}}{K_D \left(1 + \sum_i \frac{F_i}{K_{D_i}}\right)}$	$\frac{V_D - V'_D}{V'_D}$	C_P or C_R

TABLE 3: Summary of different binding potential measures, their V_3 notation, expansion in terms of concentration and affinity of binding sites (the bracketed term on the bottom allows for competition), their calculation and the input function required

The estimation of these parameters for reversible reference tissue approaches with respect to radioligand binding are summarised in Table 4.

Tissue		Impulse Response(s)	Parameter
Reference	Target		
\mathcal{R}	\mathcal{R}	$\sum_{i=1}^n \phi_i e^{-\theta_i t}, \sum_{j=1}^m \phi'_j e^{-\theta'_j t}$	$BP.f_1 = \sum_{i=1}^n \frac{\phi_i}{\theta_i} - \sum_{j=1}^m \frac{\phi'_j}{\theta'_j}$
\mathcal{R}	\mathcal{R}	$\phi_0 \delta(t) + \sum_{i=1}^{m+n-1} \phi_i e^{-\theta_i t}$	$BP.f_2 = \phi_0 + \sum_{i=1}^n \frac{\phi_i}{\theta_i} - 1$

TABLE 4: Summary of binding potential measures derived from impulse response functions

Particular Compartmental Structures

The reference tissue input model began as a 5 parameter model, the individual deliveries being unidentifiable without a plasma input function, leading to a reparameterisation of the original 6 parameter system. This reparameterisation introduces a parameter for the ratio of influxes (or relative delivery) as R_I (or R_1) = $\frac{K_1}{K'_1}$ (Blomqvist et al., 1989; Cunningham et al., 1991). With the assumption of equal Blood Brain Barrier transport rate constant ratios the model reduces to a 4 parameter system (Cunningham et al., 1991). The simplified reference tissue model assumes rapid exchange between the free and non-specific compartments and has 3 parameters (Lammertsma and Hume, 1996). Finally, the Watabe reference tissue model returns to a 5 parameter formulation (Watabe et al., 2000). These models are summarised in Appendix C.2.

Model Indistinguishability

To address the issue of the bias in the simplified reference tissue model for some tracers Watabe (Watabe et al., 2000) proposed a model with two tissues in the reference region. The theory presented here (Corollary 3.3) proves that the 'Watabe' reference tissue model is indistinguishable from the original reference tissue model (with 5 parameters) and will give the same value for the $BP.f_2$. (Note: the 'Watabe' model may behave slightly differently if the rate constants k_5 and k_6 are fitted from a range of data initially (Watabe et al., 2000) and if there is significant contribution from blood activity to the tissue signals).

Reference Tissue Model Bias

Recently, there has been some discussion about the biases that may be introduced by using the simplified reference tissue model (Parsey et al., 2000; Alpert et al., 2000; Gunn et al., 2000; Slifstein et al., 2000). A bias may be introduced for reference tissue input models in two ways; either from blood volume contribution to the tissue signals or from the use of a reduced order model. Theorem 3.6 summarises the blood volume induced biases for reference tissue input models. An expression for the blood volume induced bias in reversible reference tissue input models, in the estimated $\widehat{BP.f_2}$, may be derived simply from Theorem 3.6 and if we assume that $V_B = V'_B$ is given by,

$$\widehat{BP.f_2} = BP.f_2 \left(\frac{V'_D}{V'_D + \frac{V_B P_B}{1 - V_B}} \right).$$

This general result shows that the bias is linear and allows the assessment of blood volume induced biases for individual radioligands. Table 5 presents these results for [^{11}C]Raclopride where the parameter values are obtained from the literature (Lammertsma et al., 1996), except for the theoretical bias which is calculated as the bracketed term in equation 4. The reciprocal of P_B was approximated by the plasma to blood ratio multiplied by the parent fraction for data at the end of the scanning period, although P_B could be obtained from a fit using a model outlined in Appendix A. Good agreement is observed between the experimentally and theoretically derived biases.

Radioligand	V_B	V'_D	P_B	Bias	
				Theory	Experimental
[^{11}C]Raclopride	0.05	0.43	1.03	0.89	0.87

TABLE 5: Bias introduced by blood signal in $BP.f_2$ for reversible reference tissue input model analysis. The theoretical scalar bias calculated from equation 4 and the value determined experimentally by comparing reference and plasma input analyses

Irreversible Systems

Dynamic radioligand PET data may exhibit irreversible characteristics when the time scale of the experiment is too short to fully characterise the (slow) reversible binding of the radioligand. Typically, longer scanning periods are impractical either due to discomfort to the subject or degradation of signal. In these situations one is restricted to parameters which represent irreversible kinetics, usually the k_3 (micro parameter) or the K_I (macro parameter). Whilst, the k_3 is often numerically unidentifiable, the K_I does not suffer from this problem. However, interpretation of the K_I parameter is often confounded by blood flow (see Table 6). Ultimately, with K_I there is always an unfortunate trade off between the specificity and the magnitude of the signal, i.e. when there is a large signal the parameter reflects blood flow and when the parameter reflects binding the signal is small.

K_I	Model	
	Plasma Input	Reference Input
$\lim_{\frac{k_3}{k_2} \rightarrow \infty} K_I$	K_1	$\frac{K_1}{V_D}$
$\lim_{\frac{k_3}{k_2} \rightarrow 0} K_I$	$\frac{f_1 k_{on} B_{max}}{1 + \sum_i \frac{F_i}{K_{D_i}}}$	$\frac{f_2 k_{on} B_{max}}{1 + \sum_i \frac{F_i}{K_{D_i}}}$

TABLE 6: Interpretation of the irreversible binding parameter K_I for the irreversible models given in Appendix C.1 and C.2

Blood and Metabolism Models

In this paper a generic model for metabolism and partitioning of parent tracer between plasma and red cells is presented. This leads to a general form for a parent input function in terms of the whole blood curve. This functional form would allow general fitting of this function to discrete blood and metabolite measures. As such this would provide a flexible kinetic model for generating plasma parent input functions rather than using arbitrary functional forms. A particular example is presented in Appendix C.3. A general approach to modelling tracer metabolism has been presented previously by Huang et al. (1991), where they consider micro parameter formulations rather than considering the general form for the impulse response function. Particular compartmental structures have also been used to describe the metabolism of the parent tracer (Lammertsma et al., 1993; Gunn, 1996; Carson et al., 1997).

Summary

This paper has presented general theory for PET compartmental models, which shows that the required macro system parameters can be determined simply from the associated impulse

response functions. The form of the relationships between the macro parameters and the impulse response function are common to all models independent of the number and topology of compartments. Choosing a particular compartmental structure with a predefined number of compartments is equivalent to choosing the number of terms in the impulse response function. Ultimately, the number of numerically identifiable components in the impulse response function that can be determined from measured PET data will depend on both the statistical noise and the experimental design. The selection of a particular compartmental structure can meet with problems either if the number of identifiable components is less than the chosen model (e.g. high noise) or more than the chosen model (e.g. heterogeneity). This paper shows that a more general approach is possible where the macro parameters could be estimated by determination of the systems impulse response function without the need for *a priori* model selection. Approaches to the fitting of PET data to these generic models are being developed.

A Generic Blood and Metabolism Model

Consider a general PET system, as illustrated in Figure 8 where the measured radioactivity data consists of the parent tracer concentration in plasma, C_P , and the whole blood concentration, C_B .

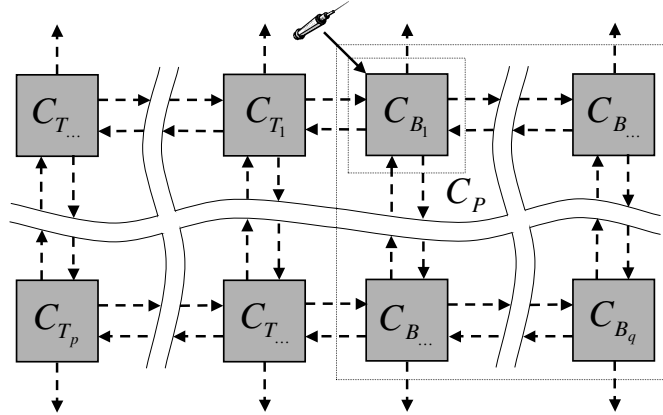

FIGURE 8: Generalised parent metabolism and blood partitioning model

Its state space formulation is given by,

$$\begin{aligned}
 \begin{bmatrix} \dot{\mathbf{C}}_B(t) \\ \dot{\mathbf{C}}_T(t) \end{bmatrix} &= \mathbf{A} \begin{bmatrix} \mathbf{C}_B(t) \\ \mathbf{C}_T(t) \end{bmatrix} + l_1 \mathbf{e}_1 U(t) \\
 \begin{bmatrix} C_B(t) \\ C_P(t) \end{bmatrix} &= \begin{bmatrix} \mathbf{1}^T & \mathbf{0}^T \\ \mathbf{e}_1^T & \mathbf{0}^T \end{bmatrix} \begin{bmatrix} \mathbf{C}_B(t) \\ \mathbf{C}_T(t) \end{bmatrix} \\
 \begin{bmatrix} \mathbf{C}_B(0) \\ \mathbf{C}_T(0) \end{bmatrix} &= \mathbf{0}.
 \end{aligned} \tag{5}$$

where $U(t)$ is the time course for the intravenous injection of tracer. Here C_{T_i} represents tissue compartments which allow for the metabolism of the parent tracer.

Lemma A.1. *The blood model defined by equation 5 is characterised by,*

$$C_B(t) = H_{BP}(t) \otimes C_P(t),$$

where the impulse response function is,

$$H_{BP}(t) = \delta(t) + \sum_{i=1}^{p+q-1} \varphi_i e^{-\vartheta_i t}$$

$\vartheta_i \geq 0$. The steady state ratio of whole blood to parent in plasma activity is,

$$\begin{aligned} P_B &= \int_0^\infty H_{BP}(t) dt, \\ &= 1 + \sum_{i=1}^{p+q-1} \frac{\varphi_i}{\vartheta_i}. \end{aligned}$$

Alternatively, the parent tracer concentration in plasma can be expressed as a function of the whole blood concentration,

$$C_P(t) = H_{PB}(t) \otimes C_B(t),$$

where

$$H_{PB}(t) = \delta(t) + \sum_{i=1}^{p+q-1} \varphi'_i e^{-\vartheta'_i t},$$

which follows from the general form of the transfer function,

$$\tilde{H}_{BP}(s) = \frac{\prod_{i=1}^{p+q-1} (s - \alpha_i)}{\prod_{j=1}^{p+q-1} (s - \beta_j)}.$$

Note: It is assumed that no multiplicity terms occur, i.e. $|Sp(\mathbf{A})| = p + q$.

B Proofs

Proof of Theorem 2.2

The state space formulation for a general plasma input model, $s \in \mathcal{M}$, is given by,

$$\begin{aligned}\dot{\mathbf{C}}_{\mathbf{T}}(t) &= \mathbf{A}\mathbf{C}_{\mathbf{T}}(t) + [\mathbf{b} \ \mathbf{0}] \begin{bmatrix} C_P(t) \\ C_B(t) \end{bmatrix} \\ C_T(t) &= (1 - V_B)\mathbf{1}^T \mathbf{C}_{\mathbf{T}}(t) + [0 \ V_B] \begin{bmatrix} C_P(t) \\ C_B(t) \end{bmatrix} \\ \mathbf{C}_{\mathbf{T}}(0) &= \mathbf{0}.\end{aligned}$$

Taking Laplace transforms yields,

$$\tilde{\mathbf{C}}_T(s) = (1 - V_B)\mathbf{1}^T [s\mathbf{I} - \mathbf{A}]^{-1} \mathbf{b} \tilde{C}_P(s) + V_B \tilde{C}_B(s),$$

and the plasma to tissue transfer function is given by,

$$\begin{aligned}\tilde{H}_{TP}(s) &= \mathbf{1}^T [s\mathbf{I} - \mathbf{A}]^{-1} \mathbf{b}, \\ &= \mathbf{1}^T \mathbf{b} \frac{\prod_{i=1}^{n-1} (s - \mu_i)}{\prod_{j=1}^n (s - \nu_j)},\end{aligned}$$

where $\nu = Sp(\mathbf{A})$ and $\mu = Sz(\mathbf{A}, \mathbf{b})$ are defined by the solutions to the following equations,

$$\begin{aligned}|\mu\mathbf{I} - \mathbf{A} + \mathbf{b}\mathbf{1}^T| - |\mu\mathbf{I} - \mathbf{A}| &= 0, \\ |\nu\mathbf{I} - \mathbf{A}| &= 0.\end{aligned}$$

The general form of the transfer function is,

$$\tilde{H}_{TP}(s) = \mathbf{1}^T \mathbf{b} \sum_{i=1}^n \frac{\rho_i}{(s - \nu_i)},$$

and the impulse response function is given by,

$$H_{TP}(t) = \mathbf{1}^T \mathbf{b} \sum_{i=1}^n \rho_i e^{\nu_i t},$$

where $\sum_{i=1}^n \rho_i = 1$. If $s \in \mathcal{R}$, V_D is equal to the step response,

$$\begin{aligned} V_D &= \int_0^{\infty} H_{TP}(t) dt, \\ &= \tilde{H}_{TP}(0), \\ &= \mathbf{1}^T \mathbf{b} \sum_{i=1}^n \frac{\rho_i}{-\nu_i}, \end{aligned}$$

and if $s \in \mathcal{I}$, ($\nu_n = 0$), the irreversible uptake rate constant from plasma is equal to the steady state response,

$$\begin{aligned} K_I &= \lim_{t \rightarrow \infty} H_{TP}(t), \\ &= \lim_{s \rightarrow 0} s \tilde{H}_{TP}(s), \\ &= \mathbf{1}^T \mathbf{b} \rho_n. \end{aligned}$$

□

Note: If the eigenvalues of \mathbf{A} are not distinct (i.e. $|Sp(\mathbf{A})| < n$) the general solution for the transfer function is,

$$\tilde{H}_{TP}(s) = \mathbf{1}^T \mathbf{b} \sum_{i=1}^n \sum_{j=1}^{q_i} \frac{\psi_{ij}}{(s - \nu_i)^j},$$

where q_i is the multiplicity of ν_i , and the impulse response function will take the form,

$$H_{TP}(t) = \mathbf{1}^T \mathbf{b} \sum_{i=1}^n \sum_{j=1}^{q_i} \rho_{ij} t^{j-1} e^{\nu_i t}.$$

Proof of Theorem 3.2

The state space formulation for a general reference tissue input model with no blood volume, $s \in \mathcal{F}$, is given by,

$$\begin{aligned} \begin{bmatrix} \dot{\mathbf{C}}_{\mathbf{T}}(t) \\ \dot{\mathbf{C}}_{\mathbf{R}}(t) \end{bmatrix} &= \begin{bmatrix} \mathbf{A} & \mathbf{0} \\ \mathbf{0} & \mathbf{A}' \end{bmatrix} \begin{bmatrix} \mathbf{C}_{\mathbf{T}}(t) \\ \mathbf{C}_{\mathbf{R}}(t) \end{bmatrix} + \begin{bmatrix} \mathbf{b} \\ \mathbf{b}' \end{bmatrix} C_P(t) \\ \begin{bmatrix} C_T(t) \\ C_R(t) \end{bmatrix} &= \begin{bmatrix} \mathbf{1}^T & \mathbf{0}^T \\ \mathbf{0}^T & \mathbf{1}^T \end{bmatrix} \begin{bmatrix} \mathbf{C}_{\mathbf{T}}(t) \\ \mathbf{C}_{\mathbf{R}}(t) \end{bmatrix} \\ \begin{bmatrix} \mathbf{C}_{\mathbf{T}}(0) \\ \mathbf{C}_{\mathbf{R}}(0) \end{bmatrix} &= \mathbf{0}. \end{aligned}$$

Taking Laplace transforms and using Theorem 2.2 yields,

$$\begin{aligned}\tilde{H}_{TR}(s) &= \frac{\tilde{H}_{TP}(s)}{\tilde{H}_{RP}(s)}, \\ &= \frac{\mathbf{1}^T \mathbf{b} \prod_{i=1}^m (s - \nu'_i) \prod_{i=1}^{n-1} (s - \mu_i)}{\mathbf{1}^T \mathbf{b}' \prod_{i=1}^n (s - \nu_i) \prod_{i=1}^{m-1} (s - \mu'_i)},\end{aligned}$$

where $\nu = Sp(\mathbf{A})$, $\mu' = Sz(\mathbf{A}', \mathbf{b}')$, $\nu' = Sp(\mathbf{A}')$ and $\mu = Sz(\mathbf{A}, \mathbf{b})$. The general form of the transfer function is,

$$\tilde{H}_{TR}(s) = \frac{\mathbf{1}^T \mathbf{b}}{\mathbf{1}^T \mathbf{b}'} \left(1 + \sum_{i=1}^n \frac{\rho_i}{(s - \nu_i)} + \sum_{i=1}^{m-1} \frac{\rho_i}{(s - \mu'_i)} \right),$$

and the impulse response function is given by,

$$H_{TR}(t) = \frac{\mathbf{1}^T \mathbf{b}}{\mathbf{1}^T \mathbf{b}'} \left(\delta(t) + \sum_{i=1}^n \rho_i e^{\nu_i t} + \sum_{i=1}^{m-1} \rho_i e^{\mu'_i t} \right).$$

If $s \in \mathcal{F}_{RR}$, the step response is given by,

$$\begin{aligned}\int_0^\infty H_{TR}(t) dt &= \tilde{H}_{TR}(0), \\ &= \frac{\mathbf{1}^T \mathbf{b}}{\mathbf{1}^T \mathbf{b}'} \left(1 + \sum_{i=1}^n \frac{\rho_i}{-\nu_i} + \sum_{i=1}^{m-1} \frac{\rho_i}{-\mu'_i} \right), \\ &= \frac{\tilde{H}_{TP}(0)}{\tilde{H}_{RP}(0)}, \\ &= \frac{V_D}{V'_D},\end{aligned}$$

if $s \in \mathcal{F}_{RI}$, ($\nu_n = 0$), the steady state response is given by,

$$\begin{aligned}\lim_{t \rightarrow \infty} H_{TR}(t) &= \lim_{s \rightarrow 0} s \tilde{H}_{TR}(s), \\ &= \frac{\mathbf{1}^T \mathbf{b}}{\mathbf{1}^T \mathbf{b}'} \rho_n, \\ &= \lim_{s \rightarrow 0} s \frac{\tilde{H}_{TP}(s)}{\tilde{H}_{RP}(s)}, \\ &= \frac{K_I}{V'_D},\end{aligned}$$

and if $s \in \mathcal{F}_{\mathcal{IL}}$, ($\nu_n = 0$), the step response is given by,

$$\begin{aligned} \int_0^\infty H_{TR}(t)dt &= \tilde{H}_{TR}(0), \\ &= \frac{\mathbf{1}^T \mathbf{b}}{\mathbf{1}^T \mathbf{b}'} \left(1 + \sum_{i=1}^{n-1} \frac{\rho_i}{-\nu_i} + \sum_{i=1}^{m-1} \frac{\varrho_i}{-\mu'_i} \right), \\ &= \frac{\tilde{H}_{TP}(0)}{\tilde{H}_{RP}(0)}, \\ &= \frac{K_I}{K'_I}. \end{aligned}$$

□

Note: If multiplicity occurs (i.e. $|Sp(\mathbf{A}) \cup Sz(\mathbf{A}', \mathbf{b}')| < n + m - 1$) the general solution for the transfer function is,

$$\tilde{H}_{TR}(s) = \frac{\mathbf{1}^T \mathbf{b}}{\mathbf{1}^T \mathbf{b}'} \left(1 + \sum_{i=1}^n \sum_{j=1}^{q_i} \frac{\psi_{ij}}{(s - \nu_i)^j} + \sum_{i=1}^{m-1} \sum_{j=1}^{r_i} \frac{\omega_{ij}}{(s - \mu'_i)^j} \right),$$

where q_i, r_i are the multiplicity of ν_i, μ'_i respectively. The impulse response function will take the form,

$$H_{TR}(t) = \frac{\mathbf{1}^T \mathbf{b}}{\mathbf{1}^T \mathbf{b}'} \left(\delta(t) + \sum_{i=1}^n \sum_{j=1}^{q_i} \rho_{ij} t^{j-1} e^{\nu_i t} + \sum_{i=1}^{m-1} \sum_{j=1}^{r_i} \varrho_{ij} t^{j-1} e^{\mu'_i t} \right).$$

Proof of Theorem 3.6

The state space formulation for a general reference tissue input model with blood volume contribution and blood kinetics defined by Lemma 1, $s \in \mathcal{G}$, is given by,

$$\begin{aligned} \begin{bmatrix} \dot{\mathbf{C}}_{\mathbf{T}}(t) \\ \dot{\mathbf{C}}_{\mathbf{R}}(t) \end{bmatrix} &= \begin{bmatrix} \mathbf{A} & \mathbf{0} \\ \mathbf{0} & \mathbf{A}' \end{bmatrix} \begin{bmatrix} \mathbf{C}_{\mathbf{T}}(t) \\ \mathbf{C}_{\mathbf{R}}(t) \end{bmatrix} + \begin{bmatrix} K_1 \mathbf{e}_1 & \mathbf{0} \\ K'_1 \mathbf{e}_1 & \mathbf{0} \end{bmatrix} \begin{bmatrix} C_P(t) \\ C_B(t) \end{bmatrix} \\ \begin{bmatrix} C_T(t) \\ C_R(t) \end{bmatrix} &= \begin{bmatrix} (1 - V_B) \mathbf{1}^T & \mathbf{0}^T \\ \mathbf{0}^T & (1 - V'_B) \mathbf{1}^T \end{bmatrix} \begin{bmatrix} \mathbf{C}_{\mathbf{T}}(t) \\ \mathbf{C}_{\mathbf{R}}(t) \end{bmatrix} + \begin{bmatrix} 0 & V_B \\ 0 & V'_B \end{bmatrix} \begin{bmatrix} C_P(t) \\ C_B(t) \end{bmatrix} \\ \begin{bmatrix} \mathbf{C}_{\mathbf{T}}(0) \\ \mathbf{C}_{\mathbf{R}}(0) \end{bmatrix} &= \mathbf{0}. \end{aligned}$$

The transfer function is given by,

$$\tilde{H}_{TR}(s) = \frac{(1 - V_B) \tilde{H}_{TP}(s) + V_B \tilde{H}_{BP}(s)}{(1 - V'_B) \tilde{H}_{RP}(s) + V'_B \tilde{H}_{BP}(s)}.$$

Using Theorem 1 and Lemma 1 yields,

$$\begin{aligned}
 \tilde{H}_{TR}(s) &= \frac{(1 - V_B) \mathbf{1}^T \mathbf{b} \frac{\prod_{i=1}^{n-1} (s - \mu_i)}{\prod_{j=1}^n (s - \nu_j)} + V_B \frac{\prod_{i=1}^{p+q-1} (s - \alpha_i)}{\prod_{j=1}^{p+q-1} (s - \beta_j)}}{(1 - V'_B) \mathbf{1}^T \mathbf{b}' \frac{\prod_{i=1}^{m-1} (s - \mu'_i)}{\prod_{j=1}^m (s - \nu'_j)} + V'_B \frac{\prod_{i=1}^{p+q-1} (s - \alpha_i)}{\prod_{j=1}^{p+q-1} (s - \beta_j)}}, \\
 &= \frac{\prod_{i=1}^m (s - \nu'_i) \left((1 - V_B) \mathbf{1}^T \mathbf{b} \prod_{j=1}^{p+q-1} (s - \beta_j) \prod_{k=1}^{n-1} (s - \mu_k) + V_B \prod_{j=1}^{p+q-1} (s - \alpha_j) \prod_{k=1}^n (s - \nu_k) \right)}{\prod_{i=1}^n (s - \nu_i) \left((1 - V'_B) \mathbf{1}^T \mathbf{b}' \prod_{j=1}^{p+q-1} (s - \beta_j) \prod_{k=1}^{m-1} (s - \mu'_k) + V'_B \prod_{j=1}^{p+q-1} (s - \alpha_j) \prod_{k=1}^m (s - \nu'_k) \right)}, \\
 &= \frac{V_B \prod_{i=1}^m (s - \nu'_i) \prod_{j=1}^{n+p+q-1} (s - \epsilon_j)}{V'_B \prod_{i=1}^n (s - \nu_i) \prod_{j=1}^{m+p+q-1} (s - \epsilon_j)}.
 \end{aligned}$$

where $\nu = Sp(\mathbf{A}), \nu' = Sp(\mathbf{A}')$ and we define the set $\Omega = \bigcup_i \epsilon_i$. The general form of the transfer function is,

$$\tilde{H}_{TR}(s) = \frac{V_B}{V'_B} \left(1 + \sum_{i=1}^n \frac{\rho_i}{(s - \nu_i)} + \sum_{j=1}^{m+p+q-1} \frac{\varrho_j}{(s - \epsilon_j)} \right),$$

and the impulse response function is given by,

$$H_{TR}(t) = \frac{V_B}{V'_B} \left(\delta(t) + \sum_{i=1}^n \rho_i e^{\nu_i t} + \sum_{j=1}^{m+p+q-1} \varrho_j e^{\epsilon_j t} \right).$$

If $s \in \mathcal{G}_{RR}$, the step response is given by,

$$\begin{aligned}
 \int_0^\infty H_{TR}(t) dt &= \tilde{H}_{TR}(0), \\
 &= \frac{V_B}{V'_B} \left(1 + \sum_{i=1}^n \frac{\rho_i}{-\nu_i} + \sum_{j=1}^{m+p+q-1} \frac{\varrho_j}{-\epsilon_j} \right), \\
 &= \frac{(1 - V_B) \tilde{H}_{TP}(0) + V_B \tilde{H}_{BP}(0)}{(1 - V'_B) \tilde{H}_{RP}(0) + V'_B \tilde{H}_{BP}(0)}, \\
 &= \frac{(1 - V_B) V_D + V_B P_B}{(1 - V'_B) V'_D + V'_B P'_B},
 \end{aligned}$$

if $s \in \mathcal{G}_{RI}$, ($\nu_n = 0$), the steady state response is given by,

$$\begin{aligned} \lim_{t \rightarrow \infty} H_{TR}(t) &= \lim_{s \rightarrow 0} s \tilde{H}_{TR}(s), \\ &= \frac{V_B}{V'_B} \rho_n, \\ &= \lim_{s \rightarrow 0} s \frac{(1 - V_B) \tilde{H}_{TP}(s) + V_B \tilde{H}_{BP}(s)}{(1 - V'_B) \tilde{H}_{RP}(s) + V'_B \tilde{H}_{BP}(s)}, \\ &= \frac{(1 - V_B) K_I}{(1 - V'_B) V'_D + V'_B P_B}, \end{aligned}$$

and if $s \in \mathcal{G}_{II}$, ($\nu_n = 0$), the step response is given by,

$$\begin{aligned} \int_0^\infty H_{TR}(t) dt &= \tilde{H}_{TR}(0), \\ &= \frac{V_B}{V'_B} \left(1 + \sum_{i=1}^{n-1} \frac{\rho_i}{-\nu_i} + \sum_{i=1}^{m+p+q-1} \frac{\rho_i}{-\varepsilon_i} \right), \\ &= \frac{(1 - V_B) \tilde{H}_{TP}(0) + V_B \tilde{H}_{BP}(0)}{(1 - V'_B) \tilde{H}_{RP}(0) + V'_B \tilde{H}_{BP}(0)}, \\ &= \frac{(1 - V_B) K_I}{(1 - V'_B) K'_I}. \end{aligned}$$

□

Note: If multiplicity occurs (i.e. $|Sp(\mathbf{A}) \cup \Omega| < n + m + p + q - 1$) the general solution for the transfer function is,

$$\tilde{H}_{TR}(s) = \frac{V_B}{V'_B} \left(1 + \sum_{i=1}^{m+n+p+q-1} \sum_{j=1}^{q_i} \frac{\psi_{ij}}{(s - \varepsilon_i)^j} \right),$$

where q_i is the multiplicity of ε_i , and the impulse response function will take the form,

$$H_{TR}(t) = \frac{V_B}{V'_B} \left(\delta(t) + \sum_{i=1}^{m+n+p+q-1} \sum_{j=1}^{q_i} \rho_{ij} t^{j-1} e^{\varepsilon_i t} \right).$$

C Examples

C.1 Plasma Input Models

This section contains explicit compartmental models and their functional forms for the commonly used PET plasma input models. Blood volume components have been omitted for simplicity.

One Tissue Compartmental Model

The compartmental structure for the one tissue compartment model (Kety and Schmidt, 1948) is shown in Figure 9.

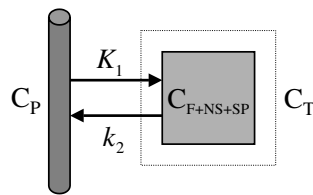

FIGURE 9: One Tissue Model

Its state space representation is defined by,

$$\mathbf{A} = [-k_2], \mathbf{b} = [K_1]. \quad (6)$$

The impulse response function and transfer function of the system are given by,

$$\begin{aligned} H_{TP}(t) &= \phi_1 e^{-\theta_1 t}, \\ \tilde{H}_{TP}(s) &= \frac{\phi_1}{s + \theta_1}, \end{aligned} \quad (7)$$

where,

$$\begin{aligned} \phi_1 &= K_1, \\ \theta_1 &= k_2. \end{aligned} \quad (8)$$

From Theorem 2.2 the V_D is given by,

$$\begin{aligned} V_D &= \frac{\phi_1}{\theta_1}, \\ &= \frac{K_1}{k_2}. \end{aligned} \quad (9)$$

Two Tissue Compartmental Model

The compartmental structure for the two tissue compartment model (Mintun et al., 1984) is shown in Figure 10.

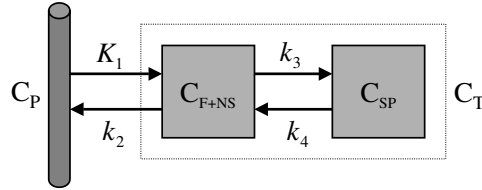

FIGURE 10: Two Tissue Model

Its state space representation is defined by,

$$\mathbf{A} = \begin{bmatrix} -k_2 - k_3 & k_4 \\ k_3 & -k_4 \end{bmatrix}, \mathbf{b} = \begin{bmatrix} K_1 \\ 0 \end{bmatrix}. \quad (10)$$

The impulse response function and transfer function of the system are given by,

$$\begin{aligned} H_{TP}(t) &= \phi_1 e^{-\theta_1 t} + \phi_2 e^{-\theta_2 t}, \\ \tilde{H}_{TP}(s) &= \frac{\phi_1}{s + \theta_1} + \frac{\phi_2}{s + \theta_2}, \end{aligned} \quad (11)$$

where,

$$\begin{aligned} \phi_1 &= \frac{K_1 (\theta_1 - k_3 - k_4)}{\Delta}, \\ \phi_2 &= \frac{K_1 (\theta_2 - k_3 - k_4)}{-\Delta}, \\ \theta_1 &= \frac{k_2 + k_3 + k_4 + \Delta}{2}, \\ \theta_2 &= \frac{k_2 + k_3 + k_4 - \Delta}{2}, \\ \Delta &= \sqrt{(k_2 + k_3 + k_4)^2 - 4 k_2 k_4}. \end{aligned} \quad (12)$$

From Theorem 2.2 the V_D is given by,

$$\begin{aligned} V_D &= \frac{\phi_1}{\theta_1} + \frac{\phi_2}{\theta_2}, \\ &= \frac{K_1}{k_2} \left(1 + \frac{k_3}{k_4} \right). \end{aligned} \quad (13)$$

Three Tissue Compartmental Model

The compartmental structure for the three tissue compartment model (Mintun et al., 1984) is shown in Figure 11.

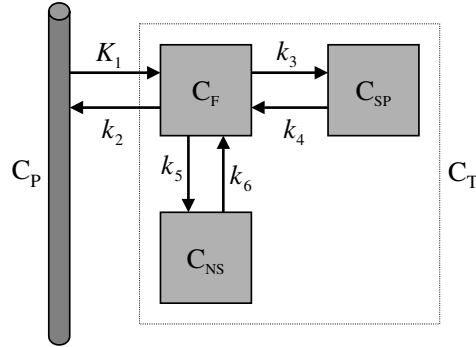

FIGURE 11: Three Tissue Model

Its state space representation is defined by,

$$\mathbf{A} = \begin{bmatrix} -k_2 - k_3 - k_5 & k_4 & k_6 \\ k_3 & -k_4 & 0 \\ k_5 & 0 & -k_6 \end{bmatrix}, \mathbf{b} = \begin{bmatrix} K_1 \\ 0 \\ 0 \end{bmatrix}. \quad (14)$$

The impulse response function and transfer function of the system are given by,

$$\begin{aligned} H_{TP}(t) &= \phi_1 e^{-\theta_1 t} + \phi_2 e^{-\theta_2 t} + \phi_3 e^{-\theta_3 t}, \\ \tilde{H}_{TP}(s) &= \frac{\phi_1}{s + \theta_1} + \frac{\phi_2}{s + \theta_2} + \frac{\phi_3}{s + \theta_3}, \end{aligned} \quad (15)$$

where,

$$\begin{aligned}
 \phi_1 &= \frac{K_1 (k_3 (k_6 - \theta_1) + (k_4 - \theta_1) (k_5 + k_6 - \theta_1))}{(\theta_1 - \theta_2) (\theta_1 - \theta_3)}, \\
 \phi_2 &= \frac{K_1 (k_3 (k_6 - \theta_2) + (k_4 - \theta_2) (k_5 + k_6 - \theta_2))}{(\theta_2 - \theta_1) (\theta_2 - \theta_3)}, \\
 \phi_3 &= \frac{K_1 (k_3 (k_6 - \theta_3) + (k_4 - \theta_3) (k_5 + k_6 - \theta_3))}{(\theta_3 - \theta_1) (\theta_3 - \theta_2)}, \\
 \theta_1 &= \frac{\Gamma_1}{3} - 2\sqrt{\Delta_1} \cos\left(\frac{\Upsilon}{3}\right), \\
 \theta_2 &= \frac{\Gamma_1}{3} - 2\sqrt{\Delta_1} \cos\left(\frac{\Upsilon + 2\pi}{3}\right), \\
 \theta_3 &= \frac{\Gamma_1}{3} - 2\sqrt{\Delta_1} \cos\left(\frac{\Upsilon + 4\pi}{3}\right), \\
 \Upsilon &= \begin{cases} \cos^{-1}\left(\sqrt{\frac{\Delta_2}{\Delta_1}}\right) & : \Delta_2 < 0 \\ \cos^{-1}\left(-\sqrt{\frac{\Delta_2}{\Delta_1}}\right) & : \Delta_2 > 0 \end{cases}, \\
 \Delta_1 &= -\frac{1}{9} (3\Gamma_2 - \Gamma_1^2), \\
 \Delta_2 &= \frac{1}{54} (2\Gamma_1^3 - 9\Gamma_1\Gamma_2 + 27\Gamma_3), \\
 \Gamma_1 &= k_2 + k_3 + k_4 + k_5 + k_6, \\
 \Gamma_2 &= k_2k_4 + k_2k_6 + k_3k_6 + k_4k_5 + k_4k_6, \\
 \Gamma_3 &= k_2k_4k_6.
 \end{aligned} \tag{16}$$

From Theorem 2.2 the V_D is given by,

$$\begin{aligned}
 V_D &= \frac{\phi_1}{\theta_1} + \frac{\phi_2}{\theta_2} + \frac{\phi_3}{\theta_3}, \\
 &= \frac{K_1}{k_2} \left(1 + \frac{k_3}{k_4} + \frac{k_5}{k_6}\right).
 \end{aligned} \tag{17}$$

Irreversible Tissue Compartmental Model

The compartmental structure for the irreversible tissue compartment model (Sokoloff et al., 1977) is shown in Figure 12.

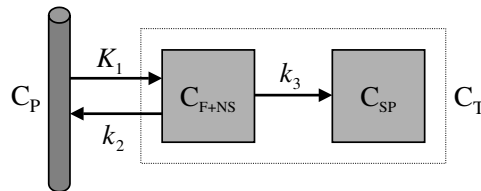

FIGURE 12: Irreversible Two Tissue Model

Its state space representation is defined by,

$$\mathbf{A} = \begin{bmatrix} -k_2 - k_3 & 0 \\ k_3 & 0 \end{bmatrix}, \mathbf{b} = \begin{bmatrix} K_1 \\ 0 \end{bmatrix}. \quad (18)$$

The impulse response function and transfer function of the system are given by,

$$\begin{aligned} H_{TP}(t) &= \phi_1 e^{-\theta_1 t} + \phi_2, \\ \tilde{H}_{TP}(s) &= \frac{\phi_1}{s + \theta_1} + \frac{\phi_2}{s}, \end{aligned} \quad (19)$$

where,

$$\begin{aligned} \phi_1 &= \frac{K_1 k_2}{k_2 + k_3}, \\ \phi_2 &= \frac{K_1 k_3}{k_2 + k_3}, \\ \theta_1 &= k_2 + k_3. \end{aligned} \quad (20)$$

From Theorem 2.2 the K_I is given by,

$$\begin{aligned} K_I &= \phi_2, \\ &= \frac{K_1 k_3}{k_2 + k_3}. \end{aligned} \quad (21)$$

C.2 Reference Tissue Input Models

This section contains explicit compartmental models and their functional forms for a range of commonly used PET reference tissue input models.

Simplified Reference Tissue Model

The compartmental structure for the simplified reference tissue model ([Lammertsma and Hume, 1996](#)) is shown in Figure 13.

Its state space representation is defined by,

$$\mathbf{A} = [-k_2], \mathbf{A}' = [-k_2'], \mathbf{b} = [K_1], \mathbf{b}' = [K_1']. \quad (22)$$

The impulse response function and transfer function of the system are given by,

$$\begin{aligned} H_{TR}(t) &= R_I (\delta(t) + \phi_1 e^{-\theta_1 t}), \\ \tilde{H}_{TR}(s) &= R_I \left(1 + \frac{\phi_1}{s + \theta_1} \right), \end{aligned} \quad (23)$$

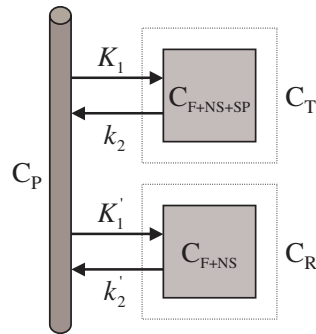

FIGURE 13: Simplified Reference Tissue Model

where,

$$\begin{aligned}
 R_I &= \frac{K_1}{K'_1}, \\
 \phi_1 &= k'_2 - k_2. \\
 \theta_1 &= k_2.
 \end{aligned}
 \tag{24}$$

From Theorem 3.2 the BP is given by,

$$\begin{aligned}
 BP.f_2 &= R_I \left(1 + \frac{\phi_1}{\theta_1} \right) - 1, \\
 &= \frac{K_1}{\frac{K'_1}{k'_2}} - 1.
 \end{aligned}
 \tag{25}$$

Full Reference Tissue Model

The compartmental structure for the full reference tissue model (Blomqvist et al., 1989; Cunningham et al., 1991; Lammertsma et al., 1996) is shown in Figure 14.

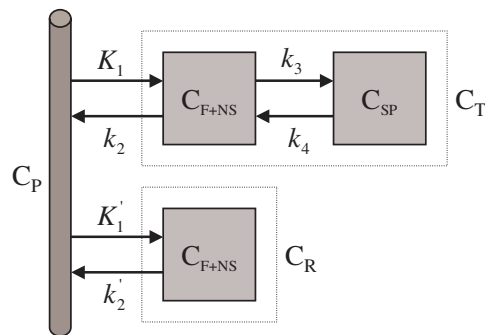

FIGURE 14: Full Reference Tissue Model

Its state space representation is defined by,

$$\mathbf{A} = \begin{bmatrix} -k_2 - k_3 & k_4 \\ k_3 & -k_4 \end{bmatrix}, \mathbf{A}' = [-k_2'], \mathbf{b} = \begin{bmatrix} K_1 \\ 0 \end{bmatrix}, \mathbf{b}' = [K_1']. \quad (26)$$

The impulse response function and transfer function of the system are given by,

$$\begin{aligned} H_{TR}(t) &= R_I (\delta(t) + \phi_1 e^{-\theta_1 t} + \phi_2 e^{-\theta_2 t}), \\ \tilde{H}_{TR}(s) &= R_I \left(1 + \frac{\phi_1}{s + \theta_1} + \frac{\phi_2}{s + \theta_2} \right), \end{aligned} \quad (27)$$

where,

$$\begin{aligned} R_I &= \frac{K_1}{K_1'}, \\ \phi_1 &= \frac{(k_2 - \theta_2)(k_2' - \theta_1)}{\Delta}, \\ \phi_2 &= \frac{(k_2 - \theta_1)(k_2' - \theta_2)}{-\Delta}, \\ \theta_1 &= \frac{k_2 + k_3 + k_4 + \Delta}{2}, \\ \theta_2 &= \frac{k_2 + k_3 + k_4 - \Delta}{2}, \\ \Delta &= \sqrt{(k_2 + k_3 + k_4)^2 - 4 k_2 k_4}. \end{aligned} \quad (28)$$

From Theorem 3.2 the BP is given by,

$$\begin{aligned} BP.f_2 &= R_I \left(1 + \frac{\phi_1}{\theta_1} + \frac{\phi_2}{\theta_2} \right) - 1, \\ &= \frac{\frac{K_1}{k_2} \left(1 + \frac{k_3}{k_4} \right)}{\frac{K_1'}{k_2'}} - 1. \end{aligned} \quad (29)$$

'Watabe' Reference Tissue Model

The compartmental structure for the 'Watabe' reference tissue model (Watabe et al., 2000) is shown in Figure 15.

Its state space representation is defined by,

$$\mathbf{A} = [-k_2], \mathbf{A}' = \begin{bmatrix} -k_2' - k_5' & k_6' \\ k_5' & -k_6' \end{bmatrix}, \mathbf{b} = [K_1], \mathbf{b}' = \begin{bmatrix} K_1' \\ 0 \end{bmatrix}. \quad (30)$$

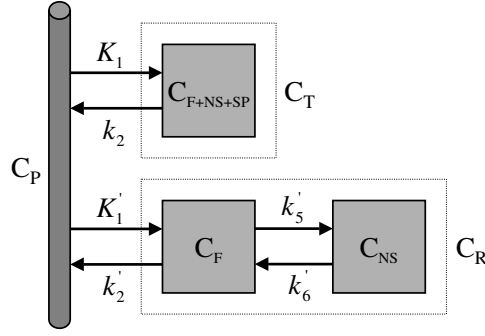

FIGURE 15: Watabe Reference Tissue Model

The impulse response function and transfer function of the system are given by,

$$\begin{aligned} H_{TR}(t) &= R_I (\delta(t) + \phi_1 e^{-\theta_1 t} + \phi_2 e^{-\theta_2 t}), \\ \tilde{H}_{TR}(s) &= R_I \left(1 + \frac{\phi_1}{s + \theta_1} + \frac{\phi_2}{s + \theta_2} \right), \end{aligned} \quad (31)$$

where,

$$\begin{aligned} R_I &= \frac{K_1}{K_1'}, \\ \phi_1 &= \frac{k_2' k_5'}{k_5' + k_6' - k_2}, \\ \phi_2 &= \frac{k_2^2 - k_2(k_2' + k_5' + k_6') + k_2' k_6'}{k_5' + k_6' - k_2}, \\ \theta_1 &= k_2, \\ \theta_2 &= k_5' + k_6'. \end{aligned} \quad (32)$$

From Theorem 3.2 the BP is given by,

$$\begin{aligned} BP.f_2 &= R_I \left(1 + \frac{\phi_1}{\theta_1} + \frac{\phi_2}{\theta_2} \right) - 1, \\ &= \frac{\frac{K_1}{k_2}}{\frac{K_1'}{k_2} \left(1 + \frac{k_5'}{k_6'} \right)} - 1. \end{aligned} \quad (33)$$

Irreversible Reference Tissue Model

The compartmental structure for the irreversible reference tissue model (Vontobel et al., 1996; Gunn et al., 1998; Houle et al., 1998) is shown in Figure 16.

Its state space representation is defined by,

$$\mathbf{A} = \begin{bmatrix} -k_2 - k_3 & 0 \\ k_3 & 0 \end{bmatrix}, \mathbf{A}' = [-k_2'], \mathbf{b} = \begin{bmatrix} K_1 \\ 0 \end{bmatrix}, \mathbf{b}' = [K_1']. \quad (34)$$

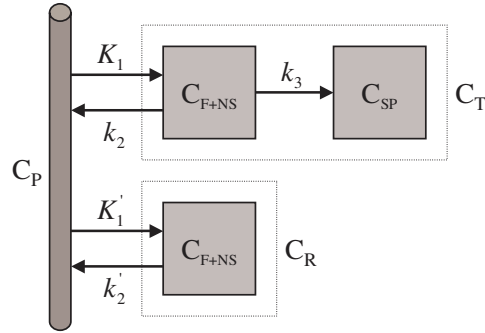

FIGURE 16: Irreversible Reference Tissue Model

The impulse response function and transfer function of the system are given by,

$$\begin{aligned}
 H_{TR}(t) &= R_I (\delta(t) + \phi_1 e^{-\theta_1 t} + \phi_2), \\
 \tilde{H}_{TR}(s) &= R_I \left(1 + \frac{\phi_1}{s + \theta_1} + \frac{\phi_2}{s} \right),
 \end{aligned} \tag{35}$$

where,

$$\begin{aligned}
 R_I &= \frac{K_1}{K_1'}, \\
 \phi_1 &= k_2' - k_2 - \frac{k_2' k_3}{k_2 + k_3}, \\
 \phi_2 &= \frac{k_2' k_3}{k_2 + k_3}, \\
 \theta_1 &= k_2 + k_3.
 \end{aligned} \tag{36}$$

From Theorem 3.2 the $\frac{K_I}{V_D'}$ is given by,

$$\begin{aligned}
 \frac{K_I}{V_D'} &= \phi_2, \\
 &= \frac{K_1 k_3}{\frac{K_1'}{k_2}}.
 \end{aligned} \tag{37}$$

C.3 Blood and Metabolism Models

Tracer Metabolism and Partitioning in Blood

A simple compartmental structure which accounts for tracer metabolism and partitioning between plasma and red cells is shown in Figure 17. Its state space representation is defined by,

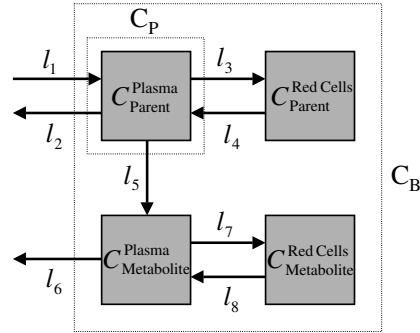

FIGURE 17: Model for Tracer Metabolism and Partitioning in Blood

$$\mathbf{A} = \begin{bmatrix} -l_2 - l_3 - l_5 & l_4 & 0 & 0 \\ l_3 & -l_4 & 0 & 0 \\ l_5 & 0 & -l_6 - l_7 & l_8 \\ 0 & 0 & l_7 & -l_8 \end{bmatrix}, \mathbf{b} = [l_1 \mathbf{e}_1] \quad (38)$$

The impulse response function and transfer function of the system are given by,

$$\begin{aligned} H_{BP}(t) &= \delta(t) + \phi_1 e^{-\theta_1 t} + \phi_2 e^{-\theta_2 t} + \phi_3 e^{-\theta_3 t}, \\ \tilde{H}_{BP}(s) &= 1 + \frac{\phi_1}{s + \theta_1} + \frac{\phi_2}{s + \theta_2} + \frac{\phi_3}{s + \theta_3}, \end{aligned} \quad (39)$$

where,

$$\begin{aligned} \phi_1 &= l_3, \\ \phi_2 &= \frac{l_5(l_7 + l_8 - \theta_1)}{\Delta}, \\ \phi_3 &= \frac{l_5(l_7 + l_8 - \theta_2)}{-\Delta}, \\ \theta_1 &= l_4, \\ \theta_2 &= \frac{(l_6 + l_7 + l_8) + \Delta}{2}, \\ \theta_3 &= \frac{(l_6 + l_7 + l_8) - \Delta}{2}, \\ \Delta &= \sqrt{(l_6 + l_7 + l_8)^2 - 4 l_6 l_8}. \end{aligned} \quad (40)$$

The steady state ratio of whole blood to parent in plasma activity is,

$$P_B = 1 + \frac{l_3}{l_4} + \frac{l_5(l_7 + l_8)}{l_6 l_8}.$$

D Glossary

Symbol	Description	Units
C_T	Target tissue concentration	$kBq.mL^{-1}$
C_R	Reference tissue concentration	$kBq.mL^{-1}$
C_P	Plasma concentration	$kBq.mL^{-1}$
C_B	Whole blood concentration	$kBq.mL^{-1}$
H_{TP}	Target tissue IRF with respect to plasma	$(mL\ plasma).min^{-1}.(mL\ tissue)^{-1}$
H_{RP}	Reference tissue IRF with respect to plasma	$(mL\ plasma).min^{-1}.(mL\ tissue)^{-1}$
H_{TR}	Target tissue IRF with respect to the reference tissue	min^{-1}
H_{BP}	Whole blood IRF with respect to parent in plasma	$(mL\ plasma).min^{-1}.(mL\ blood)^{-1}$
H_{PB}	Parent in plasma IRF with respect to whole blood	$(mL\ blood).min^{-1}.(mL\ plasma)^{-1}$
V_D	Total volume of distribution of the target tissue	$(mL\ plasma).(mL\ tissue)^{-1}$
V_{DF}	Volume of distribution of the free compartment	$(mL\ plasma).(mL\ tissue)^{-1}$
V_{DNS}	Volume of distribution of the non-specific compartment	$(mL\ plasma).(mL\ tissue)^{-1}$
V_{DSP}	Volume of distribution of the specific compartment	$(mL\ plasma).(mL\ tissue)^{-1}$
V_B	Fractional blood volume	Unitless
K_1	Plasma to brain transport constant	$(mL\ plasma).min^{-1}.(mL\ tissue)^{-1}$
R_I	Relative delivery to the target versus the reference tissue	Unitless
BP	Binding potential	$(mL\ plasma).(mL\ tissue)^{-1}$
$BP.f_1$	Product of binding potential and the plasma 'free fraction'	$(mL\ plasma).(mL\ tissue)^{-1}$
$BP.f_2$	Product of binding potential and the tissue 'free fraction'	Unitless
B_{max}	Maximum concentration of binding sites	nM
K_D	Equilibrium dissasociation rate constant	nM
K_I	Irreversible uptake rate constant from plasma for the target tissue	$(mL\ plasma).min^{-1}.(mL\ tissue)^{-1}$
k_2	Brain to plasma transport constant	min^{-1}
k_3	First order association rate constant for specific binding	min^{-1}
k_4	Disassociation rate constant for specific binding	min^{-1}
k_5	Association rate constant for non-specific binding	min^{-1}
k_6	Disassociation rate constant for non-specific binding	min^{-1}
l_i	Rate constants for blood/plasma and parent/metabolite model	min^{-1}
\otimes	Convolution operator	n/a
$Sp(\mathbf{A})$	Spectrum of \mathbf{A} , or poles of the transfer function derived from \mathbf{A}	n/a
$Sz(\mathbf{A}, \mathbf{b})$	Set of zeroes of the transfer function derived from \mathbf{A} and \mathbf{b}	n/a
$ S $	Cardinality of a set S	n/a

Acknowledgements

The authors wish to thank Federico Turkheimer and John Aston for useful discussions and comments on the manuscript.

References

- Alpert, N. M., Bonab, A., and Fischman, A. J. (2000). Conditions for the validity of the simplified reference region model. *NeuroImage*, 11(6):S56.
- Blomqvist, G., Pauli, S., Farde, L., Ericksson, L., Persson, A., and Halldin, C. (1989). *Clinical Research and Clinical Diagnosis (C. Beckers, A. Goffinet, and A. Bol, Eds)*, chapter : Dynamic models of reversible ligand binding. Kluwer Academic Publishers.
- Carson, R. E., Breier, A., de Bartolomeis, A., Saunders, R. C., Su, T. P., Schmall, B., Der, M. G., Pickar, D., and Eckelman, W. C. (1997). Quantification of amphetamine-induced changes in [11C]raclopride binding with continuous infusion. *J Cereb Blood Flow Metab*, 17(4):437–47.
- Cunningham, V. J., Hume, S. P., Price, G. R., Ahier, R. G., Cremer, J. E., and Jones, A. K. (1991). Compartmental analysis of diprenorphine binding to opiate receptors in the rat in vivo and its comparison with equilibrium data in vitro. *J Cereb Blood Flow Metab*, 11(1):1–9.
- Godfrey, K. (1983). *Compartmental Models and Their Applications*. London, Academic Press.
- Goldberg, K. (1956). A matrix with real characteristic roots. *J Res National Bureau of Standards*, 56(2):87.
- Gunn, R. N. (1996). *Mathematical modelling and identifiability applied to positron emission tomography data*. PhD thesis, University of Warwick.
- Gunn, R. N., Houle, S., and Lammertsma, A. A. (1998). Investigation of irreversible reference tissue models for parametric imaging. *NeuroImage*, 7(4):A24.
- Gunn, R. N., Lammertsma, A. A., Hume, S. P., and Cunningham, V. J. (1997). Parametric imaging of ligand-receptor binding in PET using a simplified reference region model. *NeuroImage*, 6(4):279–287.
- Gunn, R. N., Lammertsma, A. A., and M., G. P. (2000). Quantitative analysis of [carbonyl-11C]WAY-100635 PET studies. *Nucl Med Biol*, 27(5):477–482.
- Houle, S., Gunn, R. N., and Lammertsma, A. A. (1998). Quantification of receptor binding for irreversible radioligands with a reference tissue method. *J Nucl Med*, 39:65P.
- Hume, S. P., Myers, R., Bloomfield, P. M., Opacka-Juffry, J., Cremer, J. E., Ahier, R. G., Luthra, S. K., Brooks, D. J., and Lammertsma, A. A. (1992). Quantitation of carbon-11-labeled raclopride in rat striatum using positron emission tomography. *Synapse*, 12:4754.
- Kety, S. S. and Schmidt, C. F. (1948). The nitrous oxide method for the quantitative determination of cerebral blood flow in man: theory, procedure and normal values. *J Clin Invest*, 27:476–483.
- Koepp, R. A., Holthoff, V. A., Frey, K. A., Kilbourn, M. R., and Kuhl, D. E. (1991). Compartmental analysis of [11C]flumazenil kinetics for the estimation of ligand transport rate and receptor distribution using positron emission tomography. *J Cereb Blood Flow Metab*, 11(5):735–44.

- Lammertsma, A. A., Bench, C. J., Hume, S. P., Osman, S., Gunn, K., Brooks, D. J., and Frackowiak, R. S. (1996). Comparison of methods for analysis of clinical [11C]raclopride studies. *J Cereb Blood Flow Metab*, 16(1):42–52.
- Lammertsma, A. A. and Hume, S. P. (1996). Simplified reference tissue model for PET receptor studies. *NeuroImage*, 4:153–8.
- Lammertsma, A. A., Hume, S. P., Bench, C. J., Luthra, S. K., Osman, S., and Jones, T. (1993). *Quantification of brain function: Tracer Kinetics and Image Analysis in Brain PET (Uemura K, Lassen NA, Jones T, Kanno I, Eds)*, chapter : Measurement of monoamine oxidase B activity using L-[11C]deprenyl: Inclusion of compartmental analysis of plasma metabolites and a new model not requiring measurement of plasma metabolites, pages 313–318. Excerpta Medica, Amsterdam.
- Laruelle, M. (2000). Imaging synaptic neurotransmission with *in vivo* binding competition techniques: A critical review. *J Cereb Blood Flow Metab*, 20(3):423–51.
- Logan, J., Fowler, J. S., Volkow, N. D., Wolf, A. P., Dewey, S. L., Schlyer, D. J., MacGregor, R. R., Hitzemann, R., Bendriem, B., Gatley, S. J., and Christman, D. R. (1990). Graphical analysis of reversible radioligand binding from time-activity measurements applied to [N-11C-methyl]-(-)-cocaine PET studies in human subjects. *J Cereb Blood Flow Metab*, 10(5):740–7.
- Mintun, M. A., Raichle, M. E., Kilbourn, M. R., Wooten, G., and Welch, M. J. (1984). A quantitative model for the *in vivo* assessment of drug binding sites with positron emission tomography. *Ann Neurol*, 15:217–227.
- Parsey, R. V., Slifstein, M., Hwang, D. R., Abi-Dargham, A., Simpson, N., Mawlawi, O., Guo, N. N., Van Heertum, R., Mann, J. J., and Laruelle, M. (2000). Validation and reproducibility of measurement of 5-HT_{1A} receptor parameters with [carbonyl-11C]WAY-100635 in humans: comparison of arterial and reference tissue input functions. *J Cereb Blood Flow Metab*, 20(7):1111–33.
- Patlak, C. S. and Blasberg, R. G. (1985). Graphical evaluation of blood-to-brain transfer constants from multiple-time uptake data. generalizations. *J Cereb Blood Flow Metab*, 5(4):584–90.
- Patlak, C. S., Blasberg, R. G., and Fenstermacher, J. D. (1983). Graphical evaluation of blood-to-brain transfer constants from multiple-time uptake data. *J Cereb Blood Flow Metab*, 3(1):1–7.
- Phelps, M. E., Huang, S. C., Hoffman, E. J., Selin, C., Sokoloff, L., and Kuhl, D. E. (1979). Tomographic measurement of local cerebral glucose metabolic rate in humans with (F-18)2-fluoro-2-deoxy-D-glucose: validation of method. *Ann Neurol*, 6(5):371–88.
- Schmidt, K. (1999). Which linear compartmental systems can be analyzed by spectral analysis of PET output data summed over all compartments ? *J Cereb Blood Flow Metab*, 19:560–569.
- Slifstein, M., Parsey, R., and Laruelle, M. (2000). Derivation of [11C]WAY-100635 binding parameters with reference tissue models: Effect of violations of model assumptions. *Nucl*

Med Biol, 27(5):487 – 492.

- Sokoloff, L., Reivich, M., Kennedy, C., DesRosiers, M. H., Patlak, C. S., Pettigrew, K. D., Sakurada, O., and Shinohara, M. (1977). The ^{14}C -deoxyglucose method for the measurement of local cerebral glucose utilisation: theory, procedure and normal values in the conscious and anaesthetized albino rat. *J Neurochem*, 28:897–916.
- Vontobel, P., Antonini, A., Psylla, M., Gunther, I., and Leenders, K. L. (1996). *Quantification of brain function in PET*, chapter 44: Evaluation of three assumptions regarding blood-brain transport of 6-[^{18}F]fluoro-L-dopa and O-methyl-dopa in healthy volunteers, pages 224–226. Academic Press.
- Watabe, H., Carson, R. E., and Iida, H. (2000). The reference tissue model: Three compartments for the reference region. *NeuroImage*, 11(6):S12.