

Potential of the “[M(CO)₃]⁺” (M = Re, Tc) Moiety for the Labeling of Biomolecules*

By R. Alberto^{1,4**}, R. Schibli¹, U. Abram³, A. Egli¹, F. F. (Russ) Knapp² and P. A. Schubiger¹

¹ Paul Scherrer Institute, Division of Radiopharmacy, CH-5232 Villigen/Switzerland

² Oak Ridge National Laboratory, Health Sciences Research Division, Oak Ridge TN 37831

³ University of Tübingen, Institute of Inorganic Chemistry, D-72076 Tübingen/Germany

⁴ Universität Zürich, Institute of Inorganic Chemistry, CH-8057 Zürich/Switzerland

(Received December 10, 1997; accepted in revised form May 22, 1997)

*Rhenium / Technetium / Organometallics /
Direct labeling / Proteins*

Summary

The synthesis of [MX₃(CO)₃]²⁻ (M = ¹⁸⁸Re, Re, ⁹⁹Tc) directly from the corresponding permethylates is described. Intermediates and byproducts have been isolated and characterized. Preliminary direct labeling studies *in vivo* revealed a slow but irreversible incorporation of “[¹⁸⁸Re(CO)₃]⁺” into intact antibodies. The best yield was 40% after 20 h with 0.8 mg/ml of intact antibody. To elucidate possible coordination sites in proteins, the synthesis and formation of model complexes has been investigated by means of ¹H NMR spectroscopy and X-ray structure analysis. A high tendency for imidazole (im) coordination has been found and is exemplified in the model complexes [ReBr(histamine)-(CO)₃] and [Re₂(μ-OH)₂(im)₂(CO)₆], which structures will be presented. Additionally, complexation with the macrocyclic thioether ligand [20-aneS6] was studied in order to establish a post-labeling protocol with this type of chelator. The structure of [(20-aneS6-OH){Tc(CO)₃}]₂²⁺ will be presented.

Introduction

A wide variety of methods for the labeling of proteins and small biologically active molecules with metallic radionuclides have been described [1–3]. The synthesis of metal complexes in general or organometallic complexes in particular, which are able to act as specific probes in biological systems, is one of the challenging topics in coordination chemistry directed toward application [4, 5]. The key role of bifunctional ligands in that respect is well known and has been subject of several review articles discussing advantages and disadvantages of the different protocols [6–8]. A broad variety of bifunctional chelators mainly based on open chained tetradentate N,S systems such as N₂S₂ (diamide dimercaptide) and N₃S (triamide mercaptide) providing high thermodynamic stability have been prepared and successfully applied with ^{188/186}Re or ^{99m}Tc for the (post- or pre-) labeling of antibodies [9–11]. Disadvantages concerning the synthesis, the handling (tendency to be oxidized) and the availability of some of these ligands limit (sometimes)

their general application. Since the most convenient labeling procedures are with radioisotopes such as ¹¹¹In or ⁹⁰Y, basically present in form of their aqua-ions, we are interested in rhenium or technetium analogues bearing, a defined number of substitution labile water molecules in the first coordination sphere. It is of further interest that ligand replacement on such a precursor can be performed with simple chelators, resulting in complexes with high kinetic rather than in such of high thermodynamic stability. The latter point in particular makes clear that such a metal center must have a d⁶ (or d³) electronic configuration and, thus, its complexes belonging to the class of organometallic compounds of the group 7 transition elements.

The “*fac*-[M(CO)₃]⁺” moiety, synthesis and properties

Little is known about the behaviour of organometallic Re- or Tc-complexes in water. Among the numerous compounds in the +I valency of these two elements only a few seem to fulfill the above-mentioned properties. In the earlier literature, the complex [NEt₄]₂[ReBr₃(CO)₃] has been described, but almost no further investigations have been performed with this starting material [12–14]. The reaction conditions for the preparation of this important synthon were optimized [15], but the method is not suitable for routine application since the synthesis demands high CO pressure and high temperature. We therefore developed a synthesis starting directly from [NBu₄][MO₄] under atmospheric CO pressure. Details of the procedure are given in Scheme 1.

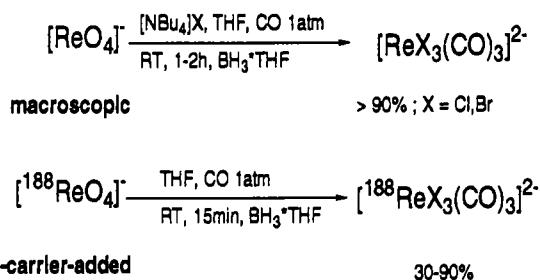

Scheme 1. Synthesis of [MX₃(CO)₃]²⁻ under ambient conditions.

* Presented at the Symposium on Radiochemistry and Radioimmunotherapy, Orlando, Florida, USA, August 1996.

** Author for correspondence.

The synthesis can be performed on the macroscopic as well as on the microscopic level with generator produced ^{188}Re or with ^{186}Re from high flux reactors. However, under these conditions, two byproducts were detected by TLC analysis of the final organic reaction solution. To elucidate their nature, the reaction was performed with ^{99}Tc . ^{99}Tc has been chosen since it allows application of the same radioanalytical methods as for $^{188/186}\text{Re}$ and, thus, a direct instant comparison. Although the chemistry of the two elements is sometimes different, the carbonylation revealed the same byproducts in detectable amounts when performing the reaction in the presence of $[\text{X}]^-$, but in quantitative yield in the absence of any $[\text{X}]^-$. The two compounds were identified as the mixed hydrido-carbonyl complexes $[\text{TcH}(\text{CO})_4]_3$ and $[\text{NBu}_4][\text{Tc}_3\text{H}_4(\text{CO})_{12}]$. The structure of the former byproduct has been elucidated by X-ray structure analysis [16]. A complete reaction scheme for the quantitative synthesis of $[\text{MX}_3(\text{CO})_3]^{2-}$ is given in Scheme 2. The two intermediates were, after completion of the synthesis, transformed to $[\text{MX}_3(\text{CO})_3]^{2-}$ by addition of base/acid. Subsequently, the organic solvent was evaporated and then replaced by a buffer medium of choice.

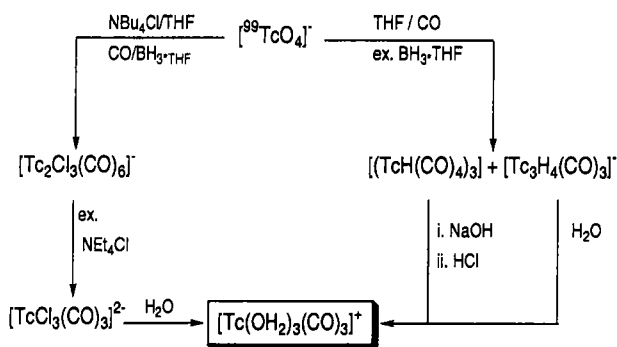

Scheme 2. Complete reaction scheme and characterized intermediates.

As described elsewhere [17] the three $[\text{X}]^-$ are readily substituted by water (or other solvent) molecules, thus, the "semi aqua-ion" $[\text{M}(\text{OH}_2)_3(\text{CO})_3]^+$ formed. This compound is water and air stable and fulfills the stability and coordination requirements pointed out above (Scheme 3).

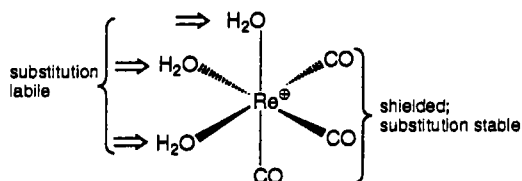

Scheme 3. Coordinative properties of $[\text{M}(\text{OH}_2)_3(\text{CO})_3]^+$.

Direct labeling of proteins with $^{188}\text{Re}(\text{OH}_2)_3(\text{CO})_3^+$

Direct labeling of proteins with ^{188}Re in parallel to $^{99\text{m}}\text{Tc}$ by introduction of thiol groups with a derivatiz-

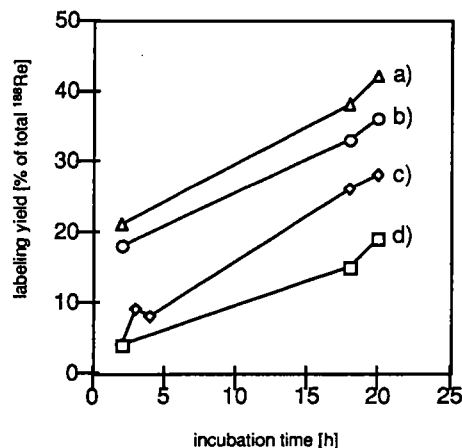

Fig. 1. Direct labeling yield as a function of antibody concentration: a) 800 μg b) 400 μg c) 300 μg and d) 200 $\mu\text{g}/\text{ml}$, 0.01 M phosphate buffer at $\text{pH} = 7.4$ and 25°C .

ing reagent such as iminothiolane or by reduction of the disulfide bridges has recently been described. It could be shown that incorporation takes place but is slow [18–20]. This corresponds to the experience, that rhenium reacts in general much slower than technetium. In comparison, qualitative labeling experiments were performed to investigate the direct interaction of $^{188}\text{Re}(\text{OH}_2)_3(\text{CO})_3^+$ with intact antibodies. The labeling process consisted in mixing the buffer solution with a underivatized protein of choice. Direct labeling of proteins with $^{188}\text{Re}(\text{OH}_2)_3(\text{CO})_3^+$ followed the same trend as observed with the reduced ones but with the decisive advantage that the protein did not have to be derivatized prior to labeling. As in the former case, incorporation was found to be slow. After purification of the labeled protein by means of size exclusion chromatography, stability tests were performed in PBS and blood serum at 37°C . TLC analysis (to detect small decomposition products) and FPLC (trans chelation to serum proteins) revealed no significant loss of $^{188}\text{Re}(\text{OH}_2)_3(\text{CO})_3^+$ over the investigated time scale (24–48 h). The labeling yield depended on the phosphate buffer concentration, which is reasonable taking the weak interaction of the $[\text{H}_2\text{PO}_4]^-/[\text{HPO}_4]^{2-}$ anions with the cationic carbonyl complex into account. Furthermore, the labeling yield was a function of protein concentration. The highest yield in the investigated range was about 40% incorporation after 20 h at *r.t.* (Fig. 1). The good linearity (yield vs. protein concentration) supports a *pseudo* first-order kinetic model. Also in agreement with this model is the fact that the labeling yield was found to depend only slightly on the absolute amount of radioactivity (Fig. 2). Increasing the amount of ^{188}Re left the yield almost untouched but increased the specific activity of the radioimmunoconjugate by the corresponding factor. In the investigated range the highest specific activity achieved was about 130 MBq/mg of protein. Biological *in vitro* activity was verified to be retained in three different experiments with the method introduced by Lindmo *et al.* [21].

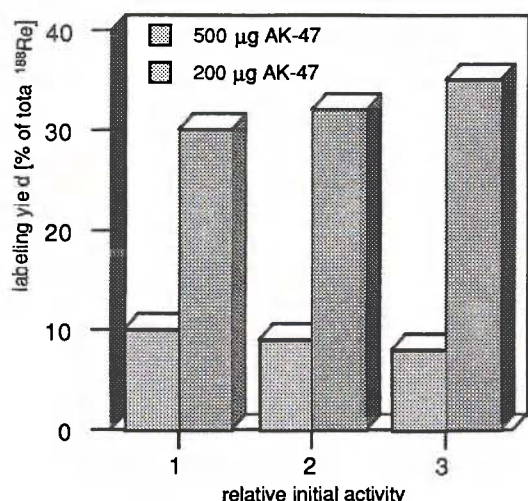

Fig. 2. Direct labeling yield as a function of amount of ¹⁸⁸Re.

It can be concluded from these results, that direct labeling of underivatized antibodies with [¹⁸⁸Re(OH₂)₃(CO)₃]⁺, providing a [¹⁸⁸Re(protein)-(OH₂)₂(CO)₃]⁺ complex of high kinetic stability is possible. The labeling rates *at r.t.* are slow but can be increased probably by factors by increasing temperature and protein concentrations, according to the observed qualitative kinetic behaviour. In terms of convenience, the protocol is easier than a prelabeling procedure with multidentate ligands, but the synthesis of the precursor complex [¹⁸⁸Re(OH₂)₃(CO)₃]⁺ has to be adapted to the requirements for a routine protocol.

It is not yet clear if the labeling takes place at a specific side chain of the amino acids in the protein or if the labeling is nonspecific. To study the interaction with various groups, several model complexes have been prepared and their properties studied. Of most interest is in particular the imidazole function (in histidine) or the thioether function (in methionine), although the concentration of the former one is low (4–20, depending on the protein) while the latter is usually located in lipophilic cavities of proteins and not readily available for complexation.

Model complexes with imidazole and histamine

These two ligands were chosen since the imidazole (im) group is part of histidine and is thus present in the hydrophilic part of proteins. Imidazole represents a monodentate ligand, whereas histamine is bidentate and can provide two coordinating sites, an aromatic and an aliphatic amine, thus, allows the elucidation of the corresponding preferences. Complexation with different metal/ligand ratios has been studied in water and in methanol. Methanol has been chosen to exclude pH equilibria and to answer the question to what extent imidazole alone is able to coordinate to the [M(CO)₃]⁺ moiety. To analyse and characterize potential intermediates, the reaction was followed by ¹H NMR spectroscopy. This method allowed the

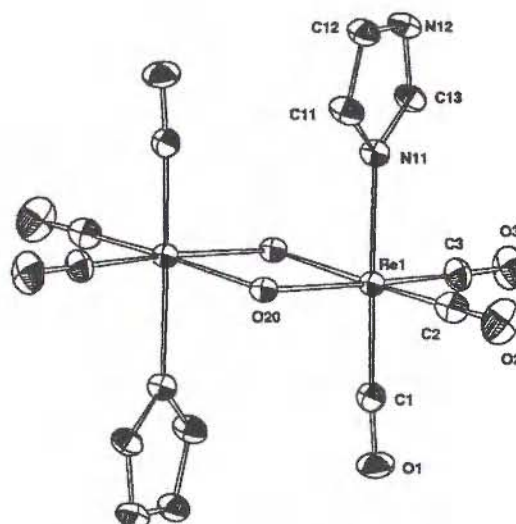
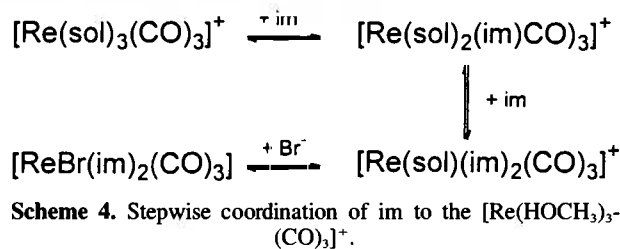

Fig. 3. ORTEP presentation of [Re₂(im)₂(μ-OH)₂(CO)₆].

characterization and isolation of the intermediates described in the reaction pathway of Scheme 4.

Substitution of a first im to [Re(HOCH₃)₃(CO)₃]⁺ occurred with a half life time of about 15 min, coordination of a second im to [Re(im)(HOCH₃)₂(CO)₃]⁺, which takes place concertedly to the first im coordination, with a half life time of about 45 min. The product [ReX(im)₂(CO)₃] was finally formed by substitution of the last [HOCH₃] by [X]⁻. This was confirmed by comparing the ¹H NMR spectra of the reaction mixture with those of the analogous compound isolated and structurally characterized. In the presence of [X]⁻, coordination of a third im is not observed. Only precipitation of [X]⁻ with [Ag]⁺ salts and subsequent reaction with 3 *eq* of im allowed the isolation of [Re(im)₃(CO)₃]⁺. This threefold coordinated species is obviously not relevant for consideration in biological processes, since coordination of a halide instead of a third im is preferred for reasons of charge compensation. The situation is slightly different in aqueous systems. At pH values below 6, the behaviour was found to be similar in that a monosubstituted complex is formed on a comparable time scale as in methanol. At physiological pH (pH > 6) however, the complexation of one im ligand per rhenium went along with [OH⁻] substitution. Two [OH⁻] bridge two rhenium centers to form finally [Re₂(im)₂(μ-OH)₂(CO)₆]. An ORTEP presentation of the molecule is depicted in Fig. 3. Acidifying such a solution to pH < 1 did not split the im from the rhenium but resulted only in OH-

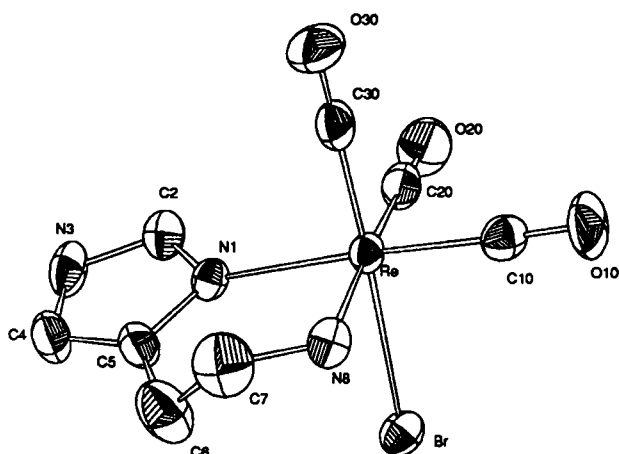

Fig. 4. ORTEP presentation of $[\text{ReBr}(\text{hist})(\text{CO})_3]$.

bridge cleaving and, thus, in the formation of $[\text{Re}(\text{im})(\text{OH}_2)_2(\text{CO})_3]^+$ demonstrating the kinetic inertness of the coordinated im group.

The extension to a bidentate ligand was performed with histamine (hist), which can provide one im ligand and one primary amine group as coordinating sites. Ligand exchange reactions in methanol revealed the same features as for imidazole alone. Slow initial coordination of one histamine was followed by incorporation of one $[\text{X}]^-$ to yield the final product $[\text{ReBr}(\text{hist})(\text{CO})_3]$ the structure of which was elucidated. An ORTEP presentation of the complex molecule is given in Fig. 4. The coordination of imidazole part and the primary amine group in histamine occurred concertedly as shown by ^1H NMR investigations. The combination of aromatic and aliphatic amines, as present in histamine, does not occur in proteins but in histidine itself (with one carbon less in the chelate ring). Since histamine, which forms highly stable complexes with $[\text{Re}(\text{OH}_2)_3(\text{CO})_3]^+$, is present as a chelating sub-unit in histidine, the uncoordinated carboxylic acid group in this amino acid could be used as a linking group to proteins. Therefore histidine might act as an interesting bifunctional ligand for the labeling of small molecules and proteins.

It can be concluded from the observed behaviour, that imidazole plays an important role in the direct labeling of proteins due to its high tendency to coordinate to $[\text{Re}(\text{OH}_2)_3(\text{CO})_3]^+$. The rate of coordination followed roughly that one observed with proteins and, once coordinated, imidazole exhibited a high kinetic stability, which is in coincidence with the behaviour observed for labeled antibodies.

Substitution behaviour with the bifunctional macrocyclic thio crown [20-aneS6-OH]

Beside the possibility of direct protein labeling, $[\text{M}(\text{OH}_2)_3(\text{CO})_3]^+$ might also be subject of a postlabeling procedure. Postlabeling is the preferred method, since labeling yield depends only on ligand exchange rate and *equilibrium* with a convenient precursor complex. Consequently, yields are usually quantitative, in contrast to those for a prelabeling procedure. The principle of postlabeling is routine for $^{99\text{m}}\text{Tc}$ but is hardly done for ^{188}Re in the +V valency due to the lack of an easily accessible and sufficiently stable precursor. $[\text{Re}(\text{OH}_2)_3(\text{CO})_3]^+$ might play this role. Proteins are derivatized with particular ligands known for strong interaction with $[\text{Re}(\text{OH}_2)_3(\text{CO})_3]^+$. Thio crowns are such ligand systems and for the labeling process they have only to be mixed with the $[\text{Re}(\text{OH}_2)_3(\text{CO})_3]^+$ complex.

To model this reaction, we have selected the [9-aneS3] and [20-aneS6-OH] thio crowns, the latter one resulting from our interest in ^{111}Ag for application in radioimmunotherapy [22]. Transchelation of $[\text{M}(\text{sol})_3(\text{CO})_3]^+$ with [9-aneS3] in organic solvents occurred within 20–30 min and the complex $[(9\text{-aneS3})\text{M}(\text{CO})_3]^+$ was formed quantitatively after this short period of time. [20-aneS6-OH] reacted on a comparable rate and, consecutively, two $[\text{M}(\text{CO})_3]^+$ fragments coordinated to yield finally the complex $[(20\text{-aneS6-OH})\{\text{Tc}(\text{CO})_3\}_2]^{2+}$. An ORTEP representation of the molecule cation is given in Fig. 5. The twofold coordination per ligand offers the possibility

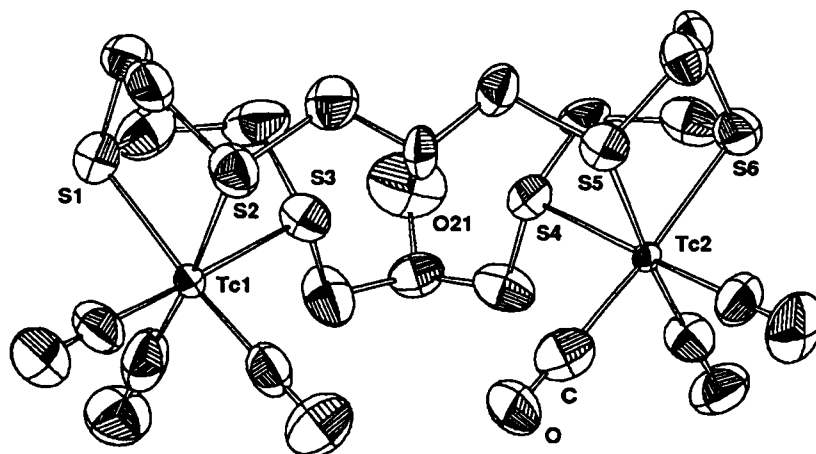

Fig. 5. ORTEP presentation of $[(20\text{-aneS6-OH})\{\text{Tc}(\text{CO})_3\}_2]^{2+}$.

of increasing the specific activity of a radioimmunoconjugate by a factor of two without increasing the number of derivatized sites. Reaction with ¹⁸⁸Re is slower and demanded a few hours for completion. If the preferred coordination site is the macrocycle or if considerable amounts of ¹⁸⁸Re is still directly bound to the protein, is under investigation.

Conclusion

The organometallic ¹⁸⁸Re precursor complex [¹⁸⁸ReX₃(CO)₃]²⁻ can be prepared directly from trace amounts of [¹⁸⁸ReO₄]⁻ in organic solvents in good yield and under similar conditions also with macroscopic amounts of Re or Tc. The "aqua-ion" [M(OH₂)₃(CO)₃]⁺, resulting from the dissolution of [¹⁸⁸ReX₃(CO)₃]²⁻ in water, is stable and provides three potential coordination sites. Substitution with different ligands showed high kinetic stability of the resulting complexes, in particular when these ligands bore an imidazole residue. Therefore, the histidine side chains seem to be responsible for direct labeling of intact antibodies, which occurred slowly but irreversibly to a maximum of 40% incorporation with retention of biological activity. [¹⁸⁸Re(OH₂)₃(CO)₃]⁺ reacts with bifunctional ligands and can chemically be treated like an aqua-ion. Especially in the case of ¹⁸⁸Re, postlabeling protocols can thus be envisaged with the appropriate ligands attached to a protein. If direct labeling occurs site specific or unspecific is under investigation.

References

- Jurisson, S., Berning, D., Jia, W., Ma, D.: *Chem. Rev.* **93**, 1137 (1993).
- Clarke, M. J., Podbielsky, L.: *Coord. Chem. Rev.* **80**, 157 (1987).
- Schubiger, P. A., Alberto, R., Smith, A.: *Bioconjugate Chem.* **7**, 165 (1996).
- Jaouen, G., Vessières, A., Top, S., Ismail, A. A., Butler, I. S.: *J. Am. Chem. Soc.* **107**, 4778 (1985).
- Salmain, M., Gunn, M., Gorfti, A., Top, S., Jaouen, G.: *Bioconjugate Chem.* **4**, 425 (1993).
- Volkert, W. A., Goeckeler, W. F., Ehrhardt, G. J., Ketring, A. R.: *J. Nucl. Med.* **32**, 174 (1991).
- Troutner, D. E.: *Nucl. Med. Biol.* **14**, 171 (1987).
- Srivastava, S. C., Mease, R. C.: *Nucl. Med. Biol.* **18**, 589 (1991).
- Vanderheyden, J.-L., Rao, T. N., Kasina, S., Wester, D., Su, F. M., Fritzberg, A. R.: *Technetium and Rhenium in Chemistry and Nuclear Medicine 3*. (M. Nicolini, G. Bandoli, U. Mazzi, eds.). Cortina International, Verona 1990, p. 623.
- Goldrosen, M. H., Biddle, W. C., Pancook, J., Bakshi, S., Vanderheyden, J.-L., Fritzberg, A. R., Morgan, A. C., Foon, K. A.: *Cancer Res.* **50**, 7973 (1990).
- Visser, G. W. M., Gerretsen, M., Herscheid, J. D. M., Snow, G. B., Van Dongen, G.: *J. Nucl. Med.* **34**, 1953 (1993).
- Abel, E. W., Hargreaves, G. B., Wilkinson, G.: *J. Chem. Soc.* 3149 (1958).
- Abel, E. W., Butler, I. S., Ganorkar, M. C., Jenkins, C. R., Stiddard, M. H. B.: *Inorg. Chem.* **5**, 25 (1966).
- Hawkes, M. J., Ginsberg, A. P.: *Inorg. Chem.* **8**, 2189 (1969).
- Alberto, R., Egli, A., Abram, U., Hegetschweiler, K., Schubiger, P. A.: *J. Chem. Soc. Dalton Trans.* 2815 (1994).
- Alberto, R., Schibli, R., Abram, U., Hübener, R., Berke, H., Kaden, T. A., Schubiger, P. A.: *J. Chem. Soc. Chem. Commun.* 1291 (1996).
- Alberto, R., Schibli, R., Egli, A., Schubiger, P. A., Herrmann, W. A., Abram, U., Kaden, T. A.: *J. Organomet. Chem.* **493**, 119 (1995).
- Zamora, P. O., Guhlke, S., Bender, H., Diekmann, D., Rhodes, B. A., Biersack, H.-J., Knapp, F. F. (Russ.): *Int. J. Cancer* **65**, 1 (1996).
- Haberberger, T., Zamora, P. O., Hosono, M., Hosono, M. N., Bender, H., Guhlke, S., Biersack, H.-J., Knapp, F. F.: M. Nicolini, B. Bandoli and U. Mazzi (Eds.), *Technetium and Rhenium in Chemistry and Nuclear Medicine*, **4**, 367, SG Editoriali, Padua, Italy (1995).
- Griffiths, G. L., Goldenberg, D. M., Diril, H., Hansen, H. J.: *Cancer Suppl.* **73**, 761 (1995).
- Lindmo, T., Bunn, P. A., *Methods Enzymol.* **121**, 678 (1986).
- Alberto, R., Nef, W., Smith, A., Frey, A., Abram, U., Kaden, T. A., Schubiger, P. A.: *Inorg. Chem.* **35**, 3420 (1996).

Direct Labeling of Antibodies IgG with Rhenium-186 Using Sodium Glucoheptonate*

By Zhihong Zhu**, Yonghui Wu, Zhiyong Zhang and Yuanfang Liu

Department of Technical Physics, Peking University, Beijing 100871, P. R. China

(Received December 10, 1996; accepted in revised form May 14, 1997)

Rhenium-186 / Direct labeling / IgG / Sodium glucoheptonate / Stabilizer / Transchelation agent

Summary

In the direct labeling of antibodies with Re-186, 188, the lower redox potential of ReO_4^- than TcO_4^- requires the addition of excess SnCl_2 and a medium-chelating agent for stabilizing the excess of SnCl_2 in solution. Through extensive tests, sodium glucoheptonate (GH) was chosen as an excellent stabilizer for SnCl_2 and also the reduced Re(V) from a variety of chelators, such as citrate, cyclodextrin, tartrate, inositol, glucose, glycine, etc. ReO_4^- solution was then quantitatively reduced for 2 h with newly prepared $\text{SnCl}_2(\text{GH})$ solution. Then, we directly incorporated the reduced Re to the antibodies IgG modified with 135 fold of NaHSO_3 and 3500 fold of 2-ME, and more than 90% of specific binding was yielded in 100–150 min at room temperature. TLC analysis indicated that less than 5% of activity was in the colloid form. Radiolabeled antibodies IgG were stable to the challenging of 700 fold of DTPA, and also showed fine *in vivo* stability.

Introduction

Re-186 has been regarded as an ideal radionuclide for radioimmunotherapy due to its appropriate half-life of 90 h and β emission of 1.07 MeV. Moreover, the γ emission of 137 keV that allows *in vitro* imaging while in therapy is an additional bonus [1]. Tumor specific monoclonal antibodies (MoAbs) are currently receiving much attention as a carrier to deliver radionuclides onto malignant tumors.

Many attempts have been made to label MoAbs with Re-186 directly or indirectly via bifunctional chelators [2–5]. Some application of the indirect labeling protocol in clinical trials even showed promise in the treatment of cancers [6–8]. However, since the indirect labeling protocol involving multisteps of synthesis, reduction, conjugation, labeling and post-purification is very inconvenient for routine preparation, hence, increasing efforts are paid to the direct labeling method.

In previous studies, the employment of SnCl_2 , $\text{Na}_2\text{S}_2\text{O}_4$ or H_3PO_2 as the reductant of ReO_4^- gave very low and varying labeling yields [4]. Though the ad-

dition of a transferring agent of citrate or tartrate drove the reduction of ReO_4^- more complete, the strong chelating ability of citrate or tartrate prevents the transchelation of reduced Re to protein. Griffiths and co-workers used a medium ligand as the transchelation agent of Re(V) and also a stabilizer of large amount of SnCl_2 . Rapid labeling of MoAbs at high yields was therefore achieved [9]. Unfortunately, no detail about this ligand was given.

In this paper, sodium glucoheptonate was chosen as a stabilizer of Sn^{2+} and a transchelation agent of Re(V) . The complete and rapid reduction of carrier-containing $^{186}\text{ReO}_4^-$ was achieved, and then the direct labeling of antibodies IgG with the reduced ^{186}Re was made.

Experimental

Human polyclonal IgG was purchased from Shanghai Institute of Biological Products, China. ^{186}Re produced by the reaction $^{185}\text{Re}(n,\gamma)^{186}\text{Re}$ in reactor was a gift from Institute of Isotopes of China Atomic Energy Academy. ^{186}Re was in a form of $\text{H}^{186}\text{ReO}_4$ with a specific activity of $1-10 \times 10^8$ Bq. Sodium glucoheptonate (GH) was prepared as previously reported [10]. All other reagents were of reagent grade.

Testing of stabilizer of Sn^{2+}

Six ligand solutions of glucose (200 mg/ml), GH(200 mg/ml), starch (saturated), inositol (200 mg/ml), cyclodextrin (saturated) and glycine (200 mg/ml) were tested.

When at pH 4.0 of acetic buffer solution (ABS), SnCl_2 stably existed in all six ligand solutions, while at pH 5.9, hydrolysis of Sn^{2+} was not observed only in GH and glycine solution. However, pH raised up to 6.2, only GH can effectively keep Sn^{2+} in solution. Therefore, GH was chosen as a suitable ligand.

Radiolabeling of antibodies IgG

1. Reduction of $^{186}\text{ReO}_4^-$

SnCl_2 solution was freshly prepared by dissolving 100 mg of $\text{SnCl}_2 \cdot 2\text{H}_2\text{O}$ in 10 μl of concentrated HCl

* Presented at the Symposium on Radiochemistry and Radioimmunotherapy, Orlando, Florida, USA, August 1996.

** Author for correspondence.

Table 1. The Rf values of different radiolabels

Radiolabel	Rf values	
	Paper chromatography	ITLC
$^{186}\text{Re-IgG}$	0.0	1.0
$^{186}\text{Re-Sn Colloid}$	0.0	0.0
$^{186}\text{Re-GH}$	1.0	1.0
$^{186}\text{ReO}_4^-$	0.8	1.0

Table 2. *In vitro* stability of $^{186}\text{Re-IgG}$ at 37°C (%)

Reductants	Challenge agent	Challenging time (hr)				
		2	4	6	18	24
2-ME	No challenge agent	87	89	92	91	94
	1:700 DTPA	87	88	90	90	89
	1:1000 EDTA	86	87	89	88	88
	1:200 MAG_3^*	56	45	41	40	38
NaHSO_3	No challenge agent	89	88	95	94	95
	1:700 DTPA	89	90	92	93	91
	1:1000 EDTA	87	80	80	80	79
	1:200 MAG_3^*	54	39	40	34	36

* MAG_3 : Mercapto-Acetyl-Glycyl-Glycyl-Glycine.

and 2 ml of H_2O , while 400 mg of GH was dissolved in 1 ml of 0.2 N ABS (pH 5.0), and then heated in boiling water to obtain a clear GH solution. The GH and SnCl_2 solutions mentioned above were mixed in a volume ratio of 5:4 to prepare $\text{Sn}(\text{GH})$ solution. The reduced ^{186}Re solution was obtained by mixing 2 ml of $\text{H}^{186}\text{ReO}_4^-$ with 1 ml of $\text{Sn}(\text{GH})$ solution and then shaking for 2 h.

2. Reduction of antibodies IgG

The antibodies were reduced with 2-mercaptoethanol (2-ME) and NaHSO_3 respectively.

For 2-ME method, IgG solution (5 mg/ml in pH 5.0, 0.1 N ABS) was reduced with 3500 molar excess of 2-ME for 30 min. This mixture was purified from excess 2-ME through a Sephadex G-50 column. The labeling was conducted by mixing 100 μl of elute with 10 μl of 0.05 M ascorbic acid, followed by incubation with 50 μl of reduced Re solution for 2 h.

For NaHSO_3 method, 200 μl of IgG solution was reduced with 30 μl of 0.03 M NaHSO_3 solution for 40 min prior to incubation with 100 μl of reduced Re solution for 2 h.

3. Quality control

The labeling yields of $^{186}\text{Re-IgG}$ was determined by paper chromatography developed in 0.9% NaCl. The

colloid formation in radiolabel was detected by instant thin-layer chromatography (ITLC). The Rf values of the involved species in ITLC and Paper Chromatograph tests are listed in Table 1.

In vitro stability of radiolabel

The stability of radiolabel was assessed by challenging the labeled IgG with 700 molar excess of DTPA, 1000 molar of EDTA and 200 molar of MAG_3 at 37°C respectively. After a time interval, the radiochemical purity was analyzed.

Animal distribution

Normal mouse of 20–25 g and 4 wk old, was injected with 100 μl of $^{186}\text{Re-IgG}$ solution through abdominal cavity. At several hours of postinjection, three mice were sacrificed, and the ID%/g in organs were determined by counting the activity of weighed organs in γ -well scintillation counter.

Results and discussion

For 2-ME method, labeling of IgG was accomplished for 150 min to give reproducible yields of 90%, and less than 5% of colloid formation was assayed by ITLC. For the method of NaHSO_3 , 2.7×10^{-3} M NaHSO_3 was used to reduce IgG in 40 min. The reduced IgG was then labeled with reduced ^{186}Re in 1 h, and the labeling yields ranged from 93% to 95%, but the activity bound to colloid was only 7.1%.

Table 1 lists the results of challenging $^{186}\text{Re-IgG}$ labeled with method of 2-ME and NaHSO_3 . It shows that the radiolabels prepared by both method of 2-ME and NaHSO_3 are considerably stable. However, in contrast to 2-ME method, the NaHSO_3 method is simple and free of further purification from 2-ME, and even gives a higher labeling yield of 95%.

The biodistribution of $^{186}\text{Re-IgG}$ labeled with 2-ME and NaHSO_3 method is plotted in Fig. 1. The distribution of $^{186}\text{Re-IgG}$ significantly differed from that of free $^{186}\text{ReO}_4^-$. The activity of $^{186}\text{ReO}_4^-$ was found to accumulate mainly in thyroid and stomach other than in kidneys and liver, while the ID%/g of the radiolabel $^{186}\text{Re-IgG}$ in liver and kidneys are much higher than that of $^{186}\text{ReO}_4^-$. Though the liver and kidney clearance appeared to be a little quick, it still fell in the range observed by other researchers [3].

For the past decade, approaches have been well established to label MoAbs directly with $^{99\text{m}}\text{Tc}(\text{V})$ [11], which chemical property is similar to that of Re. However, the redox potential for the reduction of ReO_4^- is about 220 mV lower than that for TcO_4^- . Re complexes are more thermodynamically stable against reduction in their higher oxidation state than the analogous Tc complexes [12]. Therefore, some stronger

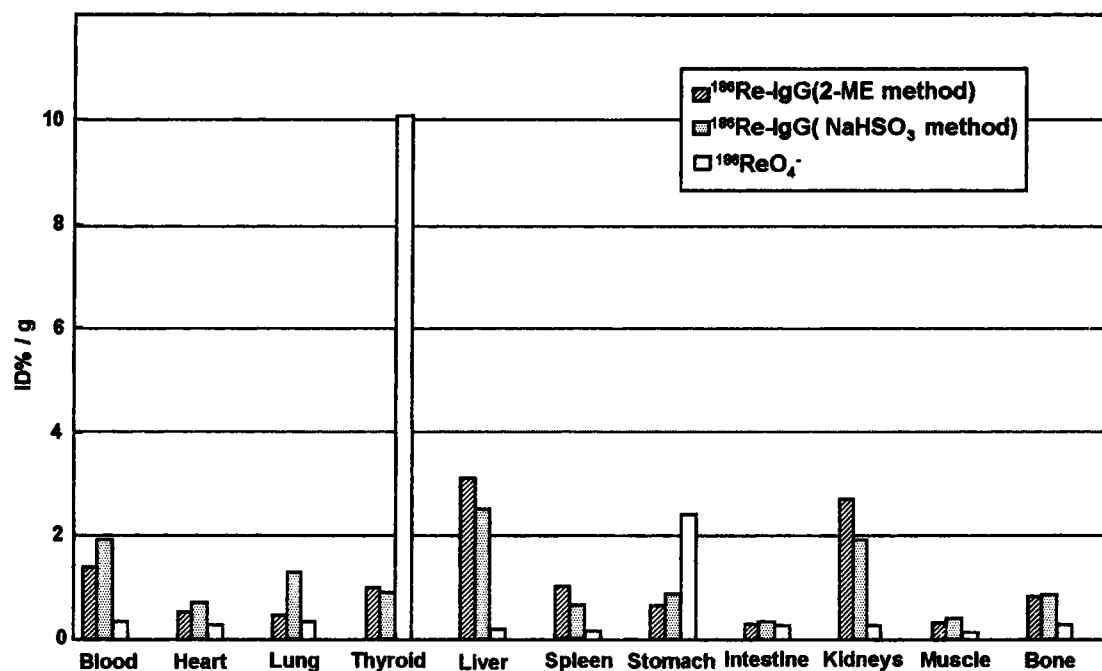

Fig. 1. Biodistribution of ^{186}Re -IgG in normal mice at 24 h post injection.

reduction conditions were usually used to reduce $^{186}\text{ReO}_4^-$, such as very acidic buffer pH, lengthening the reducing time, adding large excess of SnCl_2 , etc. Generally, only the addition of large amount of SnCl_2 was widely accepted. Nevertheless, large excess of SnCl_2 hydrolyzes at pH 4–10 [13]. Though ReO_4^- can be firstly reduced at pH 1–2, the reduced Re will be reoxidized to perrhenate by ambient O_2 while pH up to 5 (12). A stabilizer to keep SnCl_2 stable in pH ≥ 4 buffer was thus required.

GH can stabilize SnCl_2 pH ≥ 4.0 , and even at near neutral pH. Also, the labeling time of 1–2 hr in our study indicated that GH did not prevent the transchelation of the reduced Re to protein. In our recent investigation, the generator-produced carrier-free ^{188}Re was readily reduced with stannous citrate and tartrate, which was in good agreement to the studies of Griffiths and Winnard [9, 14]. While labeling with carrier-containing ^{186}Re , the presence of large amount of carrier ^{185}Re necessitates the addition of much more excess of SnCl_2 than that needed in case of carrier-free ^{188}Re . Accordingly, large amount of strong stabilizer, such as citrate or tartrate, should be added to stabilize Sn^{2+} , but it will prevent the subsequent transchelation of reduced Re(V) to protein.

We have found that GH, a transchelation agent and a stabilizer with medium chelating ability, could successfully be applied for direct labeling of antibodies IgG with carrier-containing ^{186}Re .

In summary, sodium glucoheptonate serving as an excellent stabilizer of Sn^{2+} at near neutral pH and the transchelation agent, we have labeled antibodies IgG with carrier containing ^{186}Re , which was reduced with 2-ME and NaHSO_3 respectively. The labeling yields

were more than 90%, and both challenging test and biodistribution results demonstrated that the radiolabel had good in vivo and in vitro stability.

Acknowledgments

The authors thank Prof. Meiyong Zhang and Mr. Zhi Yang of Beijing Tumor Institute and Prof. Yongxin Fang of PLA General Hospital for their advices in labeling of MoAbs. The authors are also grateful to Prof. Xiaohai Jin for his generous supply of ^{186}Re . This work was financially supported by National Natural Science Foundation of China.

References

1. Liu, Y. F., Wu, C. C.: Radiolabeling of Monoclonal Antibodies with Metal Chelates. *Pure Appl. Chem.* **63**, 427 (1991).
2. Visser, G. W. M., Gerretsen, M., Herscheid, J. D. M.: Labeling of Monoclonal Antibodies with Rhenium-186 Using MAG3 Chelate for Radioimmunotherapy of Cancer: A Technical Protocol. *J. Nucl. Med.* **34**, 260 (1993).
3. John, E., Thakur, M. I., Defulvio, J.: Rhenium-186 Labeled Monoclonal Antibodies for Radioimmunotherapy: Preparation and Evaluation. *J. Nucl. Med.* **34**, 260 (1993).
4. Quadri, S. M., Wessels, B. W.: Radiolabeled Biomolecules with ^{186}Re : Potential for Radioimmunotherapy. *Nucl. Med. Biol.* **13**, 447 (1986).
5. Griffiths, G. L., Goldenberg, D. M.: Technetium-99m, Rhenium-186 and Rhenium-188 Direct Labeled Antibodies. *Cancer* **73**, 761 (1994).
6. Gerretsen, M., Visser, G. W. M.: ^{186}Re -Labeled Monoclonal Antibody E48 Immunoglobulin G-mediated Therapy of Hu-

- man Head and Neck Squamous Cell Carcinoma Xenografts. *Cancer Res.* **53**, 3524 (1993).
7. Breitz, H. B., Weiden, P. L., Vanderheyden, J. L.: Clinical Experience with Rhenium-186 Labeled Monoclonal Antibodies for Radioimmunotherapy: Results of Phase I Trials. *J. Nucl. Med.* **33**, 1099 (1992).
 8. Stray, J. E., Vessella, R. L.: Direct Labeling of the Antirenal Carcinoma Antibody A6H with Rhenium-186: Targeting of Human Renal Cell Carcinoma Xenografts. *Antibody, Immunol. Radiopharm.* **1**, 84 (1993).
 9. Griffiths, G. L., Goldenberg, D. M., Knapp, F. F.: Direct Radio Labeling of Monoclonal Antibodies with Generator-produced Rhenium-188 for Radioimmunotherapy. *Cancer Res.* **51**, 4594 (1991).
 10. Kuang, Q. F., Guo, Y. Z., Lou, B.: The Synthesis of ^{99m}Tc -GH and Animal Biodistribution. *China Nucl. Med. Sci.* **6**, 73 (1986).
 11. Rhodes, B. A.: Direct Labeling of Proteins with ^{99m}Tc . *Nucl. Med. Biol.* **18**, 667 (1991).
 12. Deutsch, E., Libson, K.: The Chemistry of Rhenium and Technetium as Related to the Use of Isotope of these Elements in Therapeutic and Diagnostic Nuclear Medicine. *Nucl. Med. Biol.* **13**, 465 (1986).
 13. Chang, W. B., Lee, K. A.: *Concise Handbook of Analytical Chemistry*, Peking University Press, Beijing 1981, p. 74.
 14. Winnard, P., Virzi, F.: Improving the Labeling of Antibodies with Re-188. *J. Nucl. Med.* **35**, 260p (1994).

Convenient Synthesis and Bioevaluation of New MAG_3 Analogs for Rhenium-Labeling of Antibodies IgG*

By Zhihong Zhu**, Yonghui Wu and Yuanfang Liu

Department of Technical Physics, Peking University, Beijing 100871, P. R. China

(Received December 10, 1996; accepted in revised form May 14, 1997)

Synthesis / Bioevaluation / MAG_3 analogs / Bifunctional chelating agents / Antibody / Re

Summary

The promising application of Mercapto-acetyl-glycyl-glycyl-glycine (MAG_3) in the radiolabeling of monoclonal antibodies with Re has attracted us to synthesize four analogs of MAG_3 as bifunctional chelating agents (BFCAs) in improved convenient routes. All the four compounds of Bz- MAG_2 -EACA, Bz- MAG -(L)-A-EACA, Bz-MA-(L)-A-G-EACA, Bz-MA-(L)-A-(L)-A-EACA, which own a long spacer of ϵ -amino caproic acid (-EACA), have been characterized with E.A., IR, MS, and 1H NMR. Bz- MAG_2 -EACA was used as BFCA to label antibodies with Re-186 according to a well-established labeling protocol. Optimization was conducted to achieve 45–48% conjugating yields, and the resulted in good *in vivo* and *in vitro* stability of the radiolabel.

Introduction

Due to the excellent nuclear properties of ^{186}Re for radioimmunotherapy, increased efforts have been made to radiolabel tumor-specific monoclonal antibodies (MoAbs) with ^{186}Re via bifunctional chelating agents (BFCAs), such as DTPA [1], triaminedithiol ligands [2], MAG_3 [3] or the others [4, 5].

As chelating agent, MAG_3 along with its analogs has received much more attention than others because of the high *in vivo* stability of MAG_3 -metal complexes. However, when the MAG_3 analogs with terminal amino acid of two or three-carbon main chain were used for labeling of MoAbs, the formation of an intermediate of five or six-membered ring will stimulate the hydrolysis of the active ester, decreasing the conjugation yield [6]. MAG_2 - γ -aminobutyric acid (MAG_2 -GABA) owning a longer carbon chain in the terminal amino acid was better to be employed as BFCA for the radiolabeling of MoAbs. Furthermore, the application of this label in clinical treatment has shown promise for the therapy of a variety of cancers [7–9]. Generally, a chain length of five or six carbon was thought to be most favorable [1].

We have synthesized four new MAG_3 analogs, which own ϵ -amino caproic acid (-EACA) as a terminal amino acid by a convenient synthetic method. The

radiolabeling of antibodies with ^{186}Re via the synthesized Bz- MAG_2 -EACA and the bioevaluation of radiolabel in normal mice were also reported.

The abbreviations described in this paper are as following: DTPA Diethylene-triamine-pentaacetic acid, Bz benzoyl, THF tetrahydrofuran, TFA trifluoroacetic acid, A alanine, G glycine, NHS N-hydroxy-succinimide, DCC dicyclohexyl carbodiimide, EDC 1-ethyl-3-(3'-dimethylaminopropyl)-carbodiimide, t-BOC t-butyloxycarbonyl, TFP tetrafluorophenol, EACA ϵ -amino caproic acid.

Experimental

Human polyclonal IgG was purchased from Shanghai Institute of Biological Products, China. The carrier-containing ^{186}Re in the form of $H^{186}ReO_4$ with a specific activity of $1-10 \times 10^8$ Bq was a gift from Isotope Institute of China Academy of Atomic Energy.

Chemical synthesis

The MAG_3 analogs were synthesized according to the synthetic routes shown in Scheme 1.

When R, R'=H, the final product is benzoyl-mercapto-acetyl-glycyl-glycyl- ϵ -amino caproic acid (Bz- MAG_2 -EACA). Besides MAG_2 -EACA, other three new MAG_3 analogs with a terminal caproic acid were synthesized.

Labeling of antibodies IgG

IgG was labeled with carrier-added ^{186}Re via Bz- MAG_2 -EACA by Visser's protocol [3]:

1. $^{186}ReO_4$ was reduced in 2 h by twice of Sn-glucose heptonate (GH) solution which was freshly prepared by mixing $SnCl_2$ (50 mg/ml) solution and GH (400 mg/ml) solution in 5:4 volume ratio.
2. Meanwhile, 5 mg of Bz- MAG_2 -EACA was dissolved in 1 ml of 0.2 N NaOH. The deprotection of benzoyl group was accomplished by incubation in boiling water for 5 min. The pH of solution was then adjusted to 9.0 with 2 N HCl.
3. 50 μ l of solution obtained above was mixed with 80 μ l of reduced Re solution prepared in step 1, and then vortexing for 30 min.

* Presented at the Symposium on Radiochemistry and Radioimmunotherapy, Orlando, Florida, USA, August 1996.

** Author for correspondence.

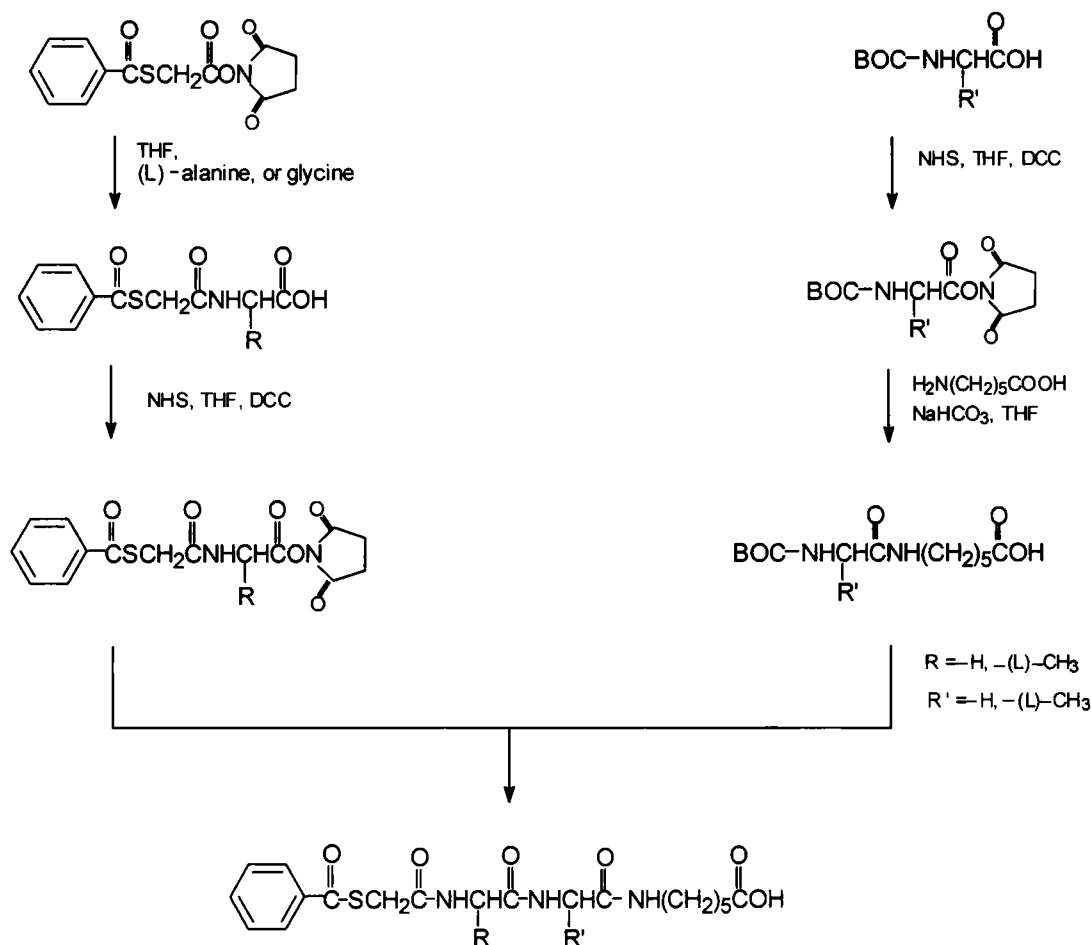

Scheme 1. Synthesis of MAG_3 analogs by active ester approach.

4. To this mixture, 30 μ l of TFP (100 mg/ml) in CH_3CN/H_2O (9:1) solution and 2 mg of EDC solid were added. Then, additional 15 μ l of CH_3CN/H_2O solution was added to keep the solution clear. The mixture was allowed to stand for 30 min.
5. The solution was heated under a stream of N_2 at 50°C to dryness, and added with 200 μ l solution of IgG (5 mg/ml) in 0.2 N carbonate buffer solution of pH 10. The conjugation was performed by incubation of 2 h.

Results and discussion

Through the outlined synthesis route, the overall yields of four new MAG_3 analogs amounted to 15.4–23.5%. In our synthetic routes, at one side Bz-mercaptoacetyl amino acid was synthesized by reaction of succinimidyl Bz-mercaptoacetate with an amino acid component, while at another side dipeptide was synthesized by another reaction of N-protected amino acid with ϵ -amino caproic acid. Therefore, the problems of low solubility of the intermediate and the inconvenient availability of dipeptide and tripeptide were solved. Furthermore, a variety of MAG_3 analogs with proper components can be feasibly synthesized following this approach.

In metal complexes of MAG_3 analogs, the carboxyl group which does not participate in the complexation can react with the lysine residues of antibodies, and can therefore be used as BFCAs for radio-labeling of MoAbs for radioimmunotherapy. The indirect radio-labeling of MoAbs with BFCAs could generally be made by two ways: 1) to label the BFCAs with radionuclide first, and then conjugate antibody with the radiolabeled chelator, or 2) conjugate the BFCAs to antibody prior to the radiolabelling of modified antibody. In the labeling of MoAbs with Bz- MAG_3 analogs as BFCAs, following the second route, the severe condition will considerably damage the immunoreactivity of MoAbs, because the deprotection of benzoyl group from the MAG_3 analogs in the labeling procedure was carried out in very basic pH environment and at high temperature, such as in boiling water. Therefore, the procedure of labeling BFCAs prior to conjugating with MoAbs was adopted in this study. With our labeling protocol, the conjugation of ^{186}Re - MAG_2 -EACA with the protein was accomplished to yield a very stable label with a reproducible yield of 48%.

In the challenging test, after 24 h of incubation in the presence of 500 fold of DTPA at 37°C, there was still 92.3% of activity bound to protein, showing that

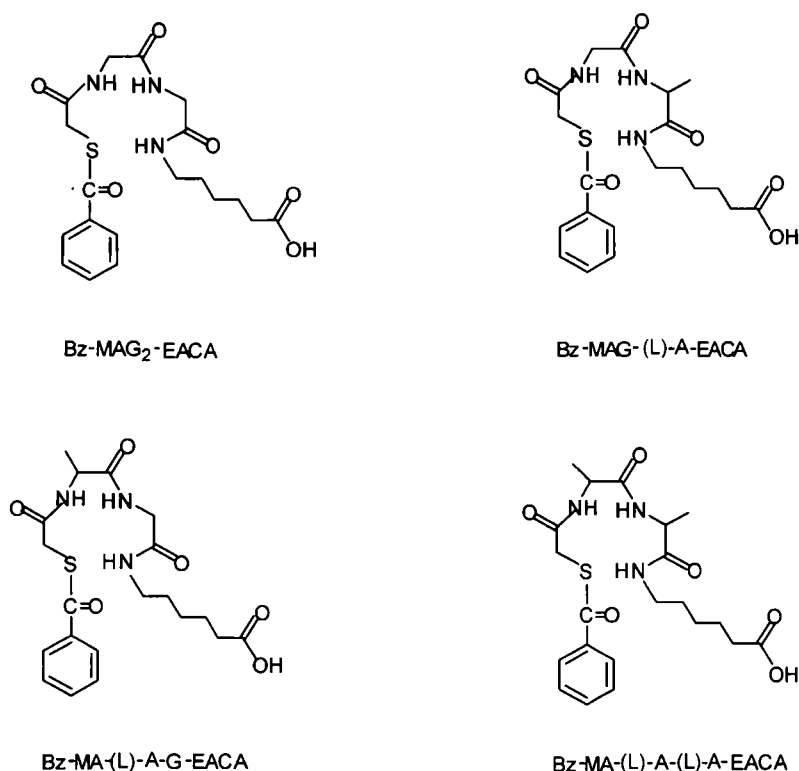

Scheme 2. Structures of the synthesized MAG₃ analogs.

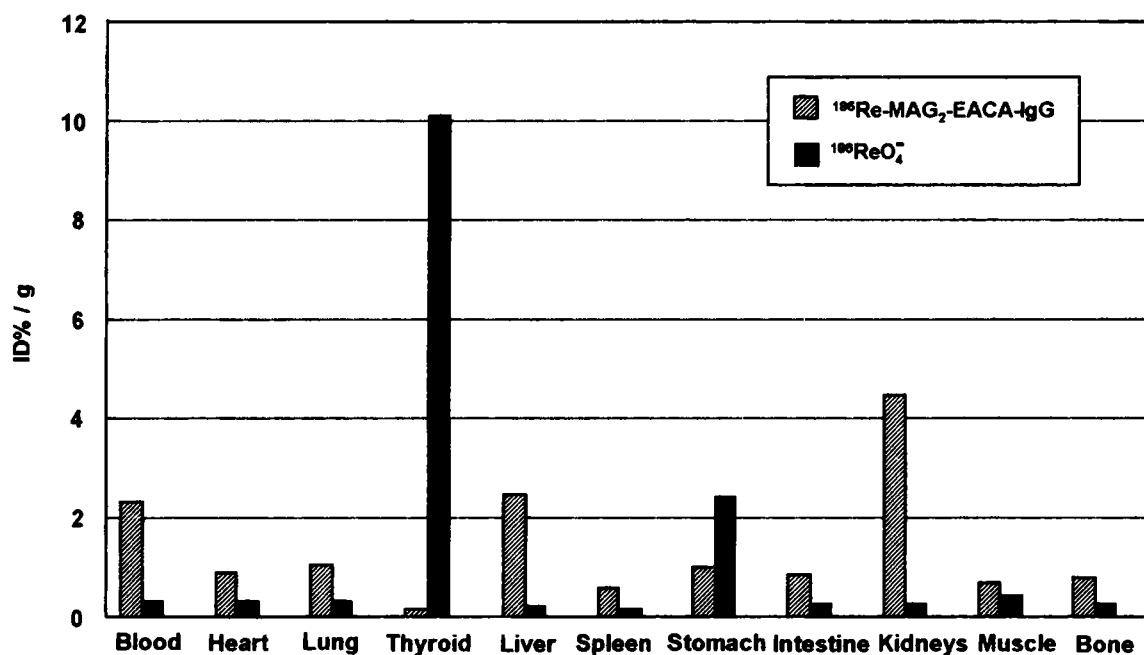

Fig. 1. Biodistribution of ¹⁸⁶Re-MAG₂-EACA-IgG in normal mice.

¹⁸⁶Re-MAG₂-EACA-IgG was very stable in vitro. Moreover, the biodistribution result of the label shown in Fig. 1 suggested its satisfactory in vivo stability. In contrast to the biodistribution of free ¹⁸⁶ReO₄⁻, only a minor activity of the label accumulated in thyroid and stomach, but a major activity in kidney and liver.

In conclusion, we have synthesized four new MAG₃ analogs which own a terminal amino acid with a longer carbon chain—ε-caproic acid. All the four compounds were characterized with IR, Elemental Analysis, MS and ¹HNMR, and the overall yields of synthesis amounted to 15.4–23.5%. Using Bz-MAG₂-

EACA as BFCA, human polyclonal IgG was labeled with ^{186}Re . The labeling yield was up to 45–48%. Both the challenging and biodistribution tests indicate that the label has good *in vitro* and *in vivo* stability.

Acknowledgment

The authors are indebted to Dr. Zhanbing Zhang of Beijing Normal University for his help in analysis of ^1H NMR and IR spectra. This work was financially supported by National Natural Science Foundation of China.

References

1. Fritzberg, A. R., Kasina, S., Eshima, D.: Metal Radionuclide Labeled Proteins for Diagnosis and Therapy. U.S. Patent 4,897,255 (1990).
2. Singh, P. R., Troutner, D. E., Ketring, A. R.: Triaminedithiol Ligands as Potential Bifunctional Chelating Agents for Tc-99m and Re-186. *J. Nucl. Med.* **32**, 985 (1991).
3. Visser, G. W. M., Gerretsen, M., Herscheid, J. D. M.: Labeling of Monoclonal Antibodies with Rhenium-186 Using the MAG_3 Chelate for Radioimmunotherapy. *J. Nucl. Med.* **34**, 1953 (1993).
4. Salmain, M., Gunn, M., Gorfti, A.: Labeling of Protein by Organometallic Complexes of Rhenium: Synthesis and Biological Activity of the Conjugates. *Bioconjugate Chem.* **4**, 425 (1993).
5. Ram, S., Buchsbaum, D. J.: A Peptide-based Bifunctional Chelating Agent for $^{99\text{m}}\text{Tc}$ and ^{186}Re -Labeling of Monoclonal Antibodies. *Cancer* **73**, 769 (1994).
6. Wilkening, D., Srinivasan, A., Kasina, S.: *J. Nucl. Med.* **30**, 261 (1989).
7. Goldrosen, M. H., Biddle, W. C., Pancok, J.: Biodistribution, Pharmacokinetic and Imaging Studies with ^{186}Re -labeled NR-LU-10 Whole Antibody in LS174T Colonic Tumor-bearing Mice. *Cancer Res.* **50**, 7973 (1990).
8. Breitz, H. B., Weiden, P. L., Vanderheyden, J. L.: Clinical Experience with Rhenium-186-labeled Monoclonal Antibodies for Radioimmunotherapy Results of Phase I Trials. *J. Nucl. Med.* **33**, 1099 (1992).
9. Schroff, R. W., Weiden, P. L., Appelbaum, J.: Rhenium-186 Labeled Antibody in Patients with Cancer: Report of a Pilot I Study. *Antibody, Immunoconjug. Radiopharm.* **3**, 99 (1990).

Rhenium-188-HEDP-kit Formulation and Quality Control*

By E. S. Verdera^{1,**}, J. Gaudio², A. León³, G. Martínez², A. Robles¹, E. Savio³, E. León¹,
D. W. McPherson⁴ and F. F. (Russ) Knapp, Jr.⁴

¹ Dept. of Radiopharm., C.I.N., F.C.; ² C. Medic. Nucl., F.M.; ³ Cát. Radioquím. F.Q., U.R.O.U., Montevideo, Uruguay;

⁴ Nuclear Medicine Group, Oak Ridge National Laboratory (ORNL), Oak Ridge, TN, USA

(Received December 10, 1996; accepted in revised form October 17, 1997)

¹⁸⁸Re-HEDP / Kit / Quality control / Animal studies / Image acquisition

Summary

¹⁸⁸Re-HEDP has been prepared from lyophilized kits with ¹⁸⁸Re from the alumina ¹⁸⁸W/¹⁸⁸Re generator for evaluation for potential, cost-effective pain relief for patients with bone metastases. SnCl₂ · 2 H₂O was used for reduction with varying amounts of Re carrier (0–300 µg per kit) and TLC was used for quality control (QC). An inert atmosphere and carrier were critical factors to achieve high radiolabeling yields in reasonable time (<10 min) and preparations were stable for at least 24 h. Slow reaction kinetics were found without carrier addition (i.e. 90% at 6 h) with low decomposition followed during 200 h under inert conditions. *In vivo* studies conducted in mice, rats and rabbits demonstrated rapid bone uptake, blood clearance, and high renal excretion with negligible liver and thyroid activity. Good images were obtained using the 155 keV gamma photon without β⁻ shielding using a medium energy-high resolution (MEHR) collimator at a distance of 2 cm. These encouraging results will be expanded to dosimetric studies and clinical trials.

Introduction

Since the chemistry of Re closely resembles technetium chemistry [1–3], the ^{99m}Tc-HEDP diagnostic agent which selectively accumulates in abnormal or cancerous tissue was used as a model for development of the Re analog. Rhenium radioisotopes (¹⁸⁶Re, ¹⁸⁸Re) have attractive properties for therapy [4–8]. ¹⁸⁸Re is obtained from a tungsten-188/rhenium-188 (¹⁸⁸W/¹⁸⁸Re), radionuclide generator system, representing an advantage for availability at radiopharmacy laboratory by daily elution [9–11]. In addition, ¹⁸⁸Re emits high energy beta particles with an average energy of 769 keV, and the emission of the 155 keV gamma photon which permits the biodistribution evaluation *in vivo* of ¹⁸⁸Re-labeled agents with a gamma camera. The feasibility of using ¹⁸⁸Re-HEDP in bone metastasis therapy was evaluated in our studies. We describe formulation studies, kit preparation, radiolabeling, quality control and *in vitro* stability studies of the radiolabeled compound, based upon the literature on commercially available ¹⁸⁶Re-HEDP and conditions for gamma camera imaging were also evaluated.

Experimental

Reagents and materials

¹⁸⁸Re-perrhenate was obtained by elution with 20 mL 0.9% saline from ¹⁸⁸W/¹⁸⁸Re generator [9] fabricated at the Oak Ridge National Laboratory (ORNL), Oak Ridge, Tennessee, that had previously been eluted 2 days earlier. For kit preparation, 1-hydroxyethylidene diphosphonic acid (Fluka AG, purity >97%), gentisic acid (Aldrich, purity = 99%), tin(II) chloride dihydrate (Baker, purity = 100%), potassium perrhenate carrier (Aldrich, purity = 99%) and high purity nitrogen gas (99.99%) were used. All other inorganic chemicals were of reagent grade.

Formulation studies and procedure for kit preparation

The kits were prepared by the following technique: 100 mg of HEDP and 30 mg of gentisic acid were dissolved in 9.7 mL of water, 37 mg of SnCl₂ · 2 H₂O was dissolved in conc. HCl and the two reagents were then combined. We studied the influence of potassium perrhenate carrier. For these studies, 10 mg of potassium perrhenate was dissolved in 1 mL of distilled water and 10, 15, 30, 100, 150 or 300 µL of this solution was added for the kit formulation mixture. This mixture was then diluted to 10 mL and dispensed into vials of 1 mL each. The vials were filled with nitrogen to produce a protecting inert gas atmosphere and stored at 2–8°C. The pH of the solutions was about 1.0–1.5.

For preparation of the lyophilized kits, each solution, under sterile conditions (laminar flow hood) was taken up into a 10 mL one way syringe, dispensed into sterile vials via a sterile filter and lyophilized for 24 hours. Kits were stored at 2–8°C. 780 mg of sodium acetate trihydrate was dissolved in 20.0 mL distilled water and was taken up into a 20 mL one way syringe and dispensed into sterile vials of 2 mL via a sterile filter. To ensure sterility of lyophilized kits, 5 vials were randomly separated, and evaluated.

Labeling procedure and quality control

A labeling kit, prepared as described above, was mixed with 1.0 mL of the generator eluate (5–20 mCi,

* Presented at the Symposium on Radiochemistry and Radioimmunotherapy, Orlando, Florida, USA, August 1996.

** Author for correspondence.

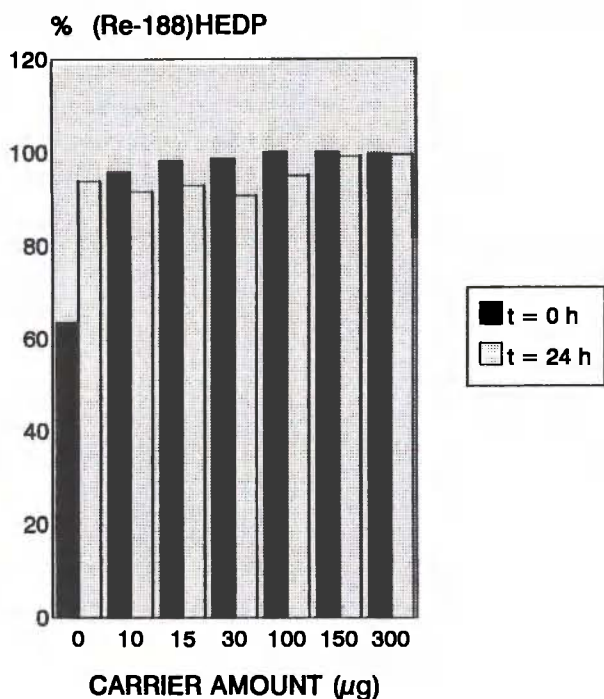

Fig. 1. Effects of carrier perrhenate on the radiolabeling efficiency and stability of the rhenium-188-HEDP complex for 24 hours.

CRC 6 Radioisotope Dose Calibrator). The solution was heated at 100°C for 10 minutes. After cooling to about room temperature, in order to achieve final pH in a range of 5–6, sodium acetate was added. The pH was controlled by pH indicator strips. Visual inspection corroborated the expected yellow color and absence of any particles.

Free perrhenate was evaluated by using chromatography paper (Whatman 1M) as the stationary phase and acetone as the mobile phase. Rhenium oxide (ReO_2) or colloids and Re-188-HEDP remained at the origin whereas Re-188-perrhenate moved with the solvent front. Rhenium oxide or colloids were evaluated using chromatography paper (Whatman 3MM) and HEDP 0.01 M in 0.9% NaCl solution as mobile phase. While the oxide and colloids remained at the origin, Re-188-HEDP and Re-188-perrhenate moved with the solvent front. After development, the strips were cut into 1 cm segments, the activity measured and the radiochemical purity calculated. In order to determine the kinetic formation of the radiolabeled compound at room temperature obtained from the different formulations, chromatographic controls were evaluated.

In vitro stability of the ^{188}Re -HEDP was studied in all formulations over 24 hour period and in the low range, from 0 to 30 μg carrier per labeling, the controls were continued for up to 200 hours.

Studies in laboratory animals

Mice (25–30 g weight) were injected with 0.05–0.1 mL of ^{188}Re -HEDP solution with 100–800 μCi

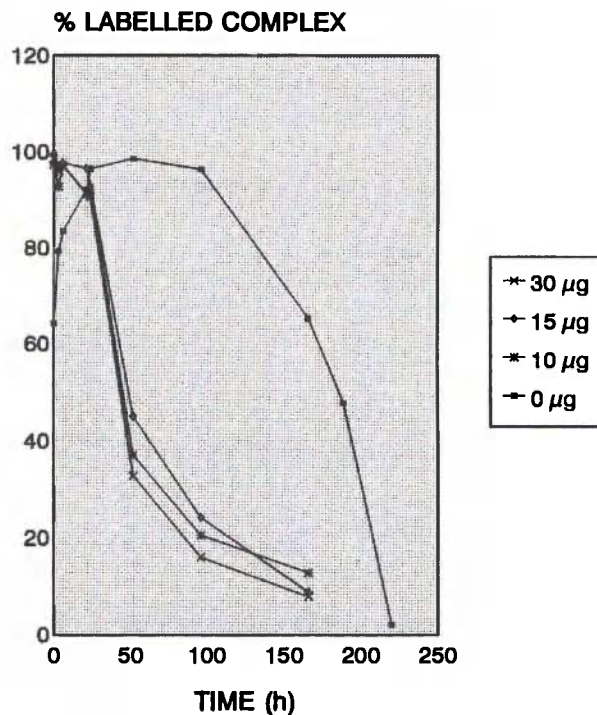

Fig. 2. Effects of carrier perrhenate on the stability of the rhenium-188-labeled HEDP complex.

Table 1. ^{188}Re -HEDP biodistribution in mice expressed as % remaining ID/organ (mean \pm 1 s.d.; $n=4$)

Tissue	2 hours	24 hours
blood	2.9 ± 1.2	1.0 ± 1.1
liver	2.3 ± 1.1	0.8 ± 0.2
lungs	0.49 ± 0.14	0.15 ± 0.26
kidney	2.4 ± 0.9	1.0 ± 0.3
thyroid	0.37 ± 0.11	0.29 ± 0.09
muscle	7.9 ± 2.2	0.02 ± 0.01
bone	65.5 ± 7.6	79.8 ± 3.1

(R.Q.P. >98%) through a lateral tail vein. Animals were sacrificed at 2 and 24 hours, and samples of blood, muscle and bone were collected in preweighed containers and other organs were removed intact. Organs and tissue samples were assayed for radioactivity [$\text{NaI}(\text{Tl})$ 3" \times 3", Ortec] and the organ uptake values then calculated as a percentage of the total remaining dose in organ at preset time. Eight-hour fasted rats (270–300 g weight) were injected with 0.1–0.2 mL (300–900 μCi), housed in metabolic cage for collection of urine and gamma camera images were done at 2 and 24 hours (Sopha Sophycamera DSK, 93 PMT, SPECT). Rats were anesthetized with 40 mg/k *i/p* pentobarbital for image acquisition. For each time point, an animal was sacrificed and organs and tissue samples were assayed as were previously described for mice. The radioactivity in whole blood, bone and muscle were calculated as 7%, 10% and 43% of the total animal weight (mice or rat).

Biodistribution of the labeled compound in rabbits (1.0–1.2 mCi *i.v.*), which were anesthetized with

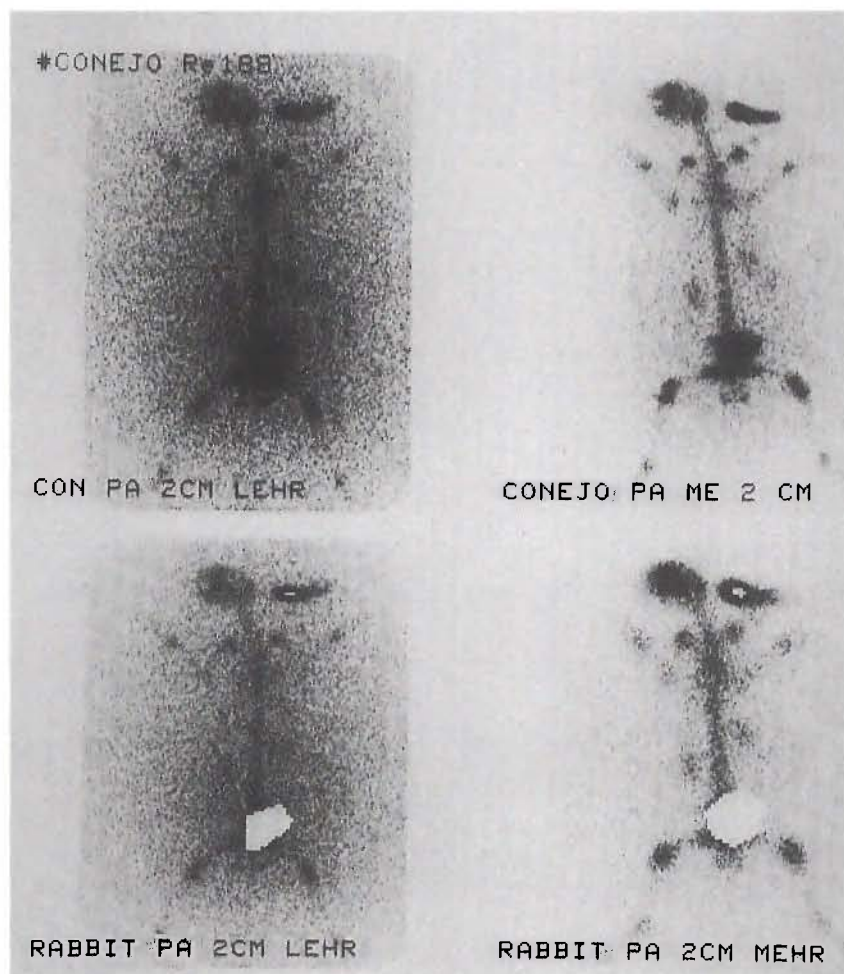

Fig. 3. Effects of low energy high resolution (LEHR), medium energy (ME), and medium energy high resolution (MEHR) collimators at a 2 cm distance on the image quality obtained with a Sopha Sohpygamma DSK Camera 24 hours after intravenous administration of rhenium-188-HEDP to rabbits.

20 mg/k l/m ketamine and 1.5 mg/k s/c phenotiazine, was also investigated by gamma camera acquisition at 2 and 24 hours.

Results

Figs. 1 and 2 illustrate the effect of carrier on kinetic formation of the radiolabeled compound and *in vitro* stability, where the kit formulation with 300 µg of potassium perrhenate conducted to a radiochemical purity of 99.5 ± 0.5 (mean \pm 1 s.d.; $n=6$) immediately after labeling, without modification during 24 hours. For this reason, this composition was selected for preparing lyophilized kits of HEDP and carrying out animals studies. Mice biodistribution results are shown in Table 1. Excreted urine, determined in these biodistributions, reached a mean of $81.6\% \pm 1.7$ (1 s.d.) in the first 2 hours. The best acquisition conditions for gamma camera imaging were determined using a medium energy high resolution (MEHR) collimator without β^- shielding at a distance of 2 cm between the animal and collimator. Fig. 3 illustrates different rabbit images in which both the distance from the collimator and the

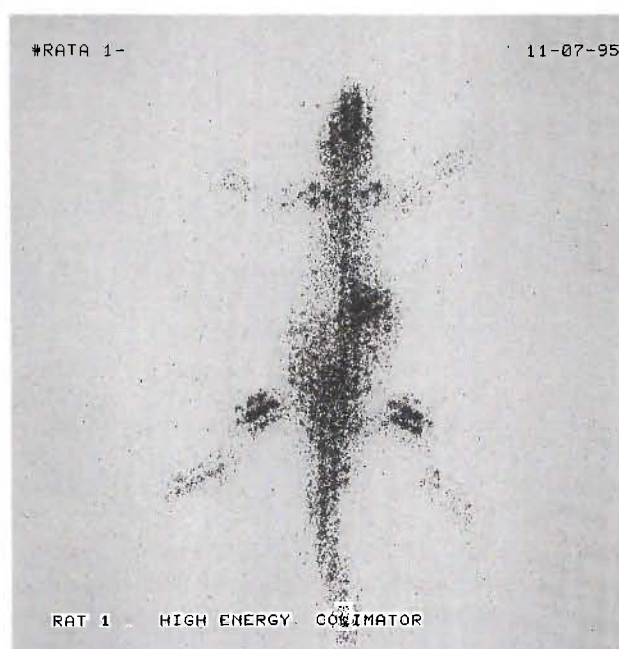

Fig. 4. Rat image obtained with a Sohpygamma DSX Camera using a MEHR collimator obtained 24 hours after intravenous administration of rhenium-188-HEDP.

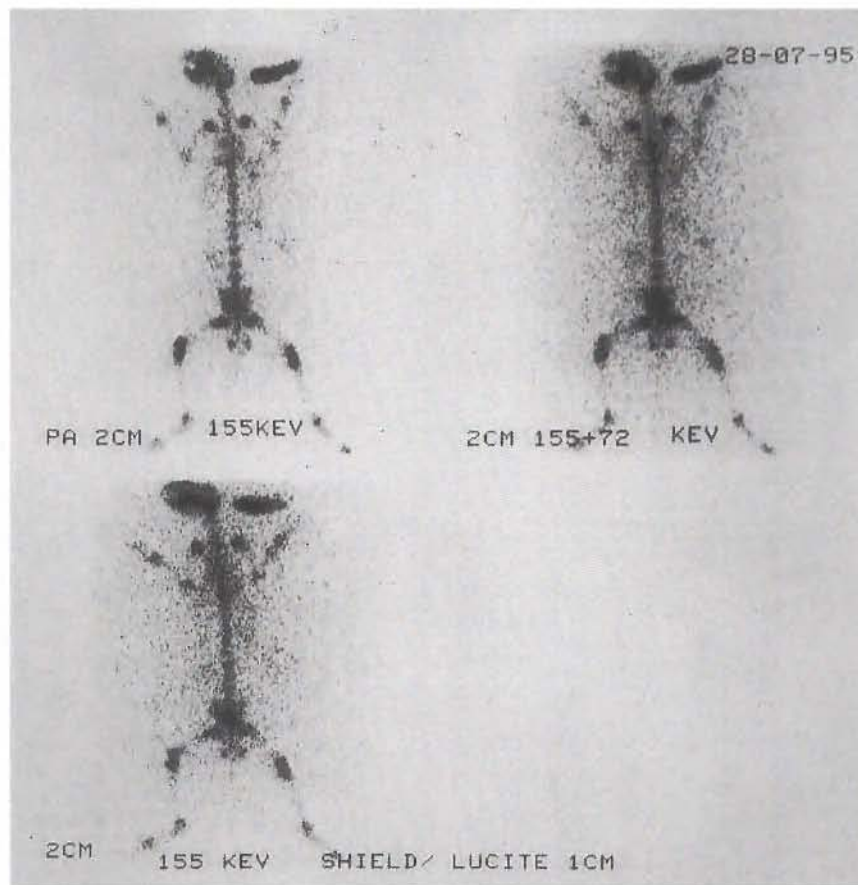

Fig. 5. Effects of gamma photon energy window setting and β^- shielding on the image quality using a MEHR collimator at a 2 cm distance with a Sopha Sohpygamma DSK Camera 24 hours after intravenous administration of rhenium-188-HEDP to rabbits.

type of collimator were varied. Fig. 4 shows a rat image obtained at 24 hours after injection and Fig. 5 shows a series of rabbit images obtained with the MEHR collimator under various imaging conditions with and without β^- shielding. Seventy percent of the administered dose was observed in rat urinary excretion at 24 hours, where 75% of the retained activity was present in bone.

Discussion and conclusions

Selected kit formulation of HEDP for labeling with Re showed that ^{188}Re -HEDP exhibits good physicochemical properties. Inert atmosphere and carrier were both critical to achieve high labeling yields (radiochemical purity >99%) in a reasonable time period. *In vitro* stability studies showed that the radiolabeled compound is stable for more than 24 hours. Non carrier added experiments indicated a low reaction rate of complex formation (90% at $t > 6$ h), however, good stability of the labeled molecule was demonstrated. Biodistribution studies in experimental animals with rhenium carrier-added preparations demonstrated rapid bone uptake and blood clearance, high renal excretion with negligible levels of activity in liver, thyroid and lungs. Good gamma camera images of rat and rabbits were acquired. The best quality of images were

achieved with a single window centered at 155 keV, without beta shielding, with an MEHR collimator and 2 cm distance between detector and source. These encouraging results will now be expanded to include dosimetric studies and clinical trials.

Acknowledgments

This work was sponsored in part by the U.S. DOE under Contract DE-ACO5-96OR22464 with Lockheed Martin Energy Research Corporation.

References

1. Deutsch, E., Libson, K., Vanderheiden, J. L., Ketering, A. R., Maxon III, H. R.: The Chemistry of Rhenium and Technetium as Related to the Use of Isotopes of these Elements in Therapeutic and Diagnostic Nuclear Medicine. *Nucl. Med. Biol.* **13**, 465–477 (1986).
2. Gambino, D., Kremer, C., Cartesio, S., Leon, A., Kremer, E.: Using Tc-Re Chemical Analogy to Synthesize and Identify New ^{99m}Tc -Complexes. *J. Radioanal. Nucl. Chem. Lett.* **136**, 341–351 (1989).
3. Deutsch, E., Libson, K., Vanderheiden, J. L.: The Inorganic Chemistry of Technetium and Rhenium as Relevant to Nuclear Medicine. In *Technetium and Rhenium in Chemistry and Nuclear Medicine 3*. (M. Nicolini, G. Bandoli and U. Mazzi, eds.), Cortina International, Verona, Italy, Raven Press, New York 13–22 (1989).

4. Eisenhut, M.: Preparation of ^{186}Re -Perrhenate for Nuclear Medicine Purposes. *Int. J. Appl. Radiat. Isot.* **33**, 99–103 (1982).
5. Mathieu, L., Chevalier, P., Galy, G., Berger, M.: Preparation of ^{186}Re Labelled HEDP and its Possible Use in Treatment of Osseous Neoplasmas. *Int. J. Appl. Radiat. Isot.* **30**, 725–727 (1979).
6. Maxon III, H. R., Thomas, S. R., Hertzberg, V. S., Schroder, L. E., Englaro, E. E., Samaratunga, R., Scher, H. I., Moulton, J. S., Deutsch, E. A., Deutsch, K., Schneider, H. J., Williams, C. C., Ehrhardt, G. J.: Rhenium-186 Hydroxyethylidene Diphosphonate for the Treatment of Painful Osseous Metastases. *Seminars in Nuclear Medicine XXII*, 33–40 (1992).
7. Van Rijk, P. P., de Klerk, J. M. H., Zonnenberg, B. A., Van het Schip, A. D., Hoekstra, A., Quirijnen, J. M. S. P., Han, S. H., Van Dijk, A.: Pain Palliation using Rhenium-186-Etidronate in Patients with Bone Metastases. In *Technetium and Rhenium in Chemistry and Nuclear Medicine 4* (M. Nicolini, G. Bandoli and U. Mazzi, eds.), Servizi Grafici Editoriali Padova, Italy, 527–534 (1995).
8. Singh, J., Reghebi, K., Lazarus, C. R., Clarke, S. E. M., Callahan, A. P., Knapp, Jr. F. F., Blower, P. J.: Studies on the Preparation and Isomeric Composition of ^{186}Re - and ^{188}Re -Pentavalent Rhenium Dimercaptosuccinic Acid Complex. *Nucl. Med. Commun.* **14**, 197–203 (1993).
9. Callahan, A. P., Rice, D. E., Knapp, Jr., F. F.: Rhenium-188 for Therapeutic Applications from an Alumina-Based Tungsten-188/Rhenium-188 Radionuclide Generator. *Nuc-Compact* **20**, 3–6 (1989).
10. Kamioki, H., Mirzadeh, S., Lambrecht, R. M., Knapp, Jr., F. F., Dadachova, K.: $^{188}\text{W}/^{188}\text{Re}$ Generator for Biomedical Applications. *Radiochim. Acta* **65**, 39–46 (1994).
11. Ehrhardt, G. J., Ketering, A. R., Turpin, T. A., Razavi, M., Vanderheiden, S., Fritzberg, A. R.: An Improved W-188/Re-188 generator for Radiotherapeutic Applications. *J. Nucl. Med.* **28**, 656–657 (1987).

Radiopharmaceutical Design Using Novel Re-188 Imido Complexes*

By Jeffrey B. Arterburn^{1**}, Keith A. Hall², Ian M. Fogarty¹, Donna M. Goreham¹,
Jeffrey C. Bryan³ and Kevin C. Ott²

¹ Department of Chemistry and Biochemistry, New Mexico State University, Box 30001/3C, Las Cruces, NM 88003, USA

² CST Division, Los Alamos National Laboratory, USA

³ CS Group, Oak Ridge National Laboratory, USA

(Received December 10, 1996; accepted in revised form April 14, 1997)

*Imido / Rhenium / Radiopharmaceutical /
Functionalized / Peptide / Steroid*

Summary

Several efficient new methods for synthesizing rhenium compounds containing a multiply bonded imido linkage ($\text{Re}=\text{N}-\text{R}$) between the metal and organic compounds for radiopharmaceutical applications are reported. The imido linkage is stable and compatible with typical organic functional groups, and offers distinct structural and synthetic advantages over other types of linkages commonly used in radiopharmaceutical design. Syntheses of representative peptide and steroid compounds from hydrazine and phosphinimine imido precursors are described, and the preparation of a ^{188}Re -imido complex is discussed. A promising new ^{188}Re -radiolabeling strategy for directly synthesizing rhenium imido radiopharmaceuticals, targeted for low-capacity receptor sites relevant for cancer therapy and based on solid supported imido precursors, is presented.

The conjugation of radionuclides to biochemical receptor ligands provides a powerful method for the selective delivery of radiopharmaceuticals to target cells and organs for diagnostic imaging and therapeutic applications [1]. Recently a great deal of interest has focused on ^{188}Re -bioconjugates prepared from peptides, antibodies, and steroids due to the potential of these compounds for selectively localizing in cancer cells, and the suitability of the radioisotope's energetic γ and β -particles for imaging and radiolysis (respectively) of small- to medium-sized tumors [2]. The development of convenient tungsten-188/rhenium-188 generator systems, analogous to the widely used molybdenum-99/technetium-99m generators, provides access to this valuable radionuclide [3]. Two critical issues facing the development of ^{188}Re radiopharmaceuticals for cancer therapy are i) the need for compounds that will accumulate at tumor sites with high selectivity, and ii) the development of synthetic methods for producing these compounds in a clinical environment. The strategic targeting of low-capacity receptor sites on tumor cells provides a mechanism for selective binding, but raises a significant new synthetic challenge as well. Most of the currently available synthetic methods use a large excess of derivatized recep-

tor ligand relative to radionuclide in order to maximize the radiolabeling efficiency. A caveat to those approaches is that the non-labeled receptor ligands must be separated in order to avoid saturating the receptor sites with non-radioactive ligands, which would limit the effectiveness of the radiotherapy. While this separation is possible using modern chromatographic techniques, it requires additional equipment, and increases the preparation time and exposure during handling. These issues are particularly important when evaluating the feasibility of radiolabeling syntheses in a clinical environment. The synthetic challenge is to develop new methodology for directly synthesizing ^{188}Re -bioconjugates without requiring an additional separation step.

Our interest has focused on using the multiply bonded organoimido group [4] ($\text{M}=\text{NR}$) as a strong, covalent linkage between a Re^{V} metal center and biologically relevant organic compounds. The use of an imido linkage potentially offers a number of advantages over traditional approaches involving multi-hapto or chelating linkages. Namely, the imido i) requires only a single point of attachment between the metal and biomolecule, thereby ii) reducing the size of the linkage and iii) allowing the remaining coordination sites on the metal to be easily varied with ligands that would enable tuning of desirable properties (solubility, charge) in order to achieve optimal biodistribution.

Complexes of the general formula $[(\text{PPh}_3)_2\text{Cl}_3\text{Re}=\text{N}-\text{R}]$ containing stable, isotopic rhenium and incorporating simple ($\text{R} = \text{aryl or alkyl}$) organic components are well known, and can be prepared by reacting the oxo complex $[(\text{PPh}_3)_2\text{Cl}_3\text{Re}=\text{O}]$ **I** with phosphinimine $[\text{C}_6\text{H}_5-\text{N}=\text{PPh}_3]$ [5] or hydrazine $[\text{C}_6\text{H}_5-\text{NHNHCOCH}_3]$ [6] derivatives. The synthetic availability of the carrier free ^{188}Re oxo complex ***I** [7] makes these routes potentially viable for the synthesis of radiopharmaceuticals, however the stability and compatibility of the imido group in the presence of organic functional groups was unknown when our investigation was initiated. In this presentation, we describe the syntheses of a variety of imido rhenium complexes containing functionalized, biologically relevant organic groups, and report a powerful new strategy for direct Re-labeling which produces product free from unreacted ligand.

We recently found that the Re^{V} oxo complex **I** reacts rapidly with functionalized N-acetyl-arylhydra-

* Presented at the Symposium on Radiochemistry and Radioimmunotherapy, Orlando, Florida, USA, August 1996.

** Author for correspondence.

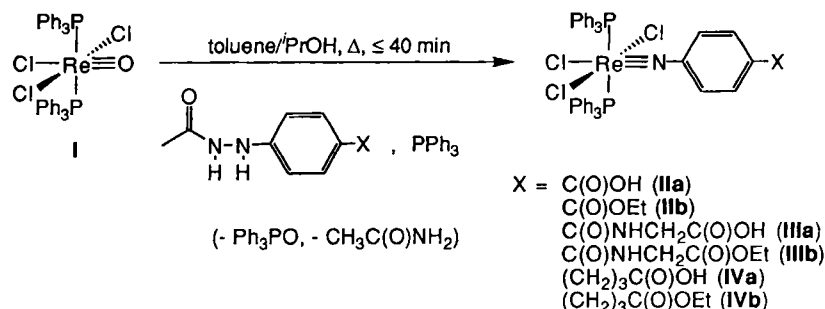

Scheme 1. Synthesis of functionalized Re imidos from arylhydrazine precursors.

zine derivatives and triphenylphosphine in a refluxing 1:1 mixture of toluene and 2-propanol to give the green, air stable aryl organoimido complexes **II–IV** (Scheme 1) [8].

The reactions proceed in high yields ($\geq 85\%$) and no precautions against air or water in the reagents are required. The complexes have been fully characterized spectroscopically (NMR, IR, elemental analysis) and the X-ray structure of complex **IVb** has been determined. $^{31}\text{P}\{^1\text{H}\}$ NMR provides a very useful means of identifying the complexes where a characteristic single resonance at ca -22 ppm for the *trans*-equivalent phosphine ligands is observed. The FT-IR spectra of the complexes display absorptions in the usual ranges for the carbonyl groups of the esters, amides and acids in the complexes. These complexes have also been characterized by HPLC utilizing a reversed-phase column (C8 on silica), and eluted without decomposition in aqueous acetonitrile. To our knowledge, complexes **IIa–IVa** represent the first examples in which an organoimido ligand and free carboxylic acid groups are present within the same molecule [9]. The efficient Re–N π -bonding in these organoimido complexes results in the weak basicity/nucleophilicity of the nitrogen atom and imparts stability to the complexes against detectable hydrolysis in the protic media used for HPLC. The complexes were also stable in acetonitrile mixtures containing up to 10% acetic acid. Further investigations of the stabilities of these complexes under physiological pH, and in the presence of biologically relevant ligands are in progress.

To test the viability of extending this chemistry to the tracer level, a synthesis of **IVb** labeled with ^{188}Re was carried out starting from a CH_2Cl_2 solution of $[\text{Re}(\text{O})\text{Cl}_3(\text{PPh}_3)_2]$ (**I***) prepared by the literature method [3]. Reaction of **I*** with an excess of the acylhydrazine and PPh_3 proceeds smoothly at room temperature to produce $[\text{Re}(\text{NC}_6\text{H}_4(\text{CH}_2)_3\text{CO}_2\text{Et})\text{Cl}_3(\text{PPh}_3)_2]$ (**IVb**) in quantitative radiochemical yield as determined by HPLC with radiometric detection.

The reactions between **I** and the 4-*t*-butylcyclohexyl acylhydrazine derivative $\text{CH}_3\text{CONH}-\text{NH}-\text{C}_6\text{H}_{10}\text{C}(\text{CH}_3)_3$ or the isoelectronic methoxylamine derivative $\text{CH}_3\text{O}-\text{NH}-\text{C}_6\text{H}_{10}\text{C}(\text{CH}_3)_3$ proceed rapidly at ambient temperature in CH_2Cl_2 to give the product alkyl organoimido complex $[(\text{PPh}_3)_2\text{Cl}_3\text{Re}\equiv\text{N}-\text{C}_6\text{H}_{10}\text{C}(\text{CH}_3)_3]$ (**V**) in 83% and 87% yields respective-

ly. Methoxylamines can be easily synthesized by the reduction of methoximes with NaBH_3CN , and represent new, convenient precursors for alkyl imido complexes. Functionalized alkylimido complexes $[(\text{PPh}_3)_2\text{Cl}_3\text{Re}\equiv\text{N}-\text{X}]$; ($\text{X} = -(\text{CH}_2)_5\text{OH}$ (**VI**); $-(\text{CH}_2)_4\text{CH}(\text{OH})\text{CO}_2\text{Et}$ (**VII**)) were also prepared in 75% and 80% yields respectively by this route. The chemistry was then extended to prepare a dihydrocholesterol derivative **VIII** from the corresponding methoxylamine. The reaction between **I** and the equatorially substituted methoxylamine produced **VIII** in excellent yields (85–92%), while the sterically hindered axially substituted diastereomer was unreactive under these conditions.

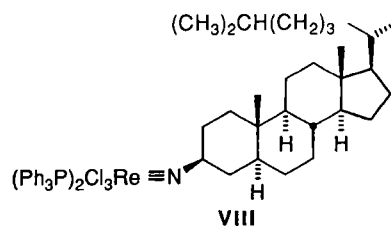

The reaction between **I** and functionalized phosphinimines $[\text{Ph}_3\text{P}=\text{N}-\text{C}_6\text{H}_4-\text{X}]$ provides another effective route for preparing the aryl organoimido complexes. Ester and amide derivatives containing the 4-azidobenzoyl group can be easily prepared from 4-azidobenzoic acid, and these react readily with PPh_3 to form the corresponding phosphinimines. The high basicity of the Zwitter-ionic phosphinimine is compatible with ester and amide derivatives but not unprotected carboxylic acid and alcohol groups [9]. The imido forming reactions with phosphinimines proceed rapidly in refluxing THF, and were used to synthesize aryl organoimido complexes containing simple amino acid derivatives such as $[(\text{PPh}_3)_2\text{Cl}_3\text{Re}\equiv\text{N}-\text{C}_6\text{H}_4\text{CO}-\text{Ala}-\text{OEt}]$ (**IX**) in 92% yield, and also an imido complex attached by amide linkages to the two ornithine residues of the cyclic decapeptide gramicidin-S $[(\text{PPh}_3)_2\text{Cl}_3\text{Re}\equiv\text{N}-\text{C}_6\text{H}_4\text{C}(\text{O})-\text{Orn}-\text{Leu}-\text{Phe}-\text{Pro}-\text{Val}-)]_2$ (**X**) in 75% yield.

The methodology presented thus far demonstrates the synthetic feasibility of imido-based rhenium radiopharmaceuticals. Consideration of the chemical similarity of the imido precursors, in which a nitrogen-heteroatom bond is cleaved during formation of the

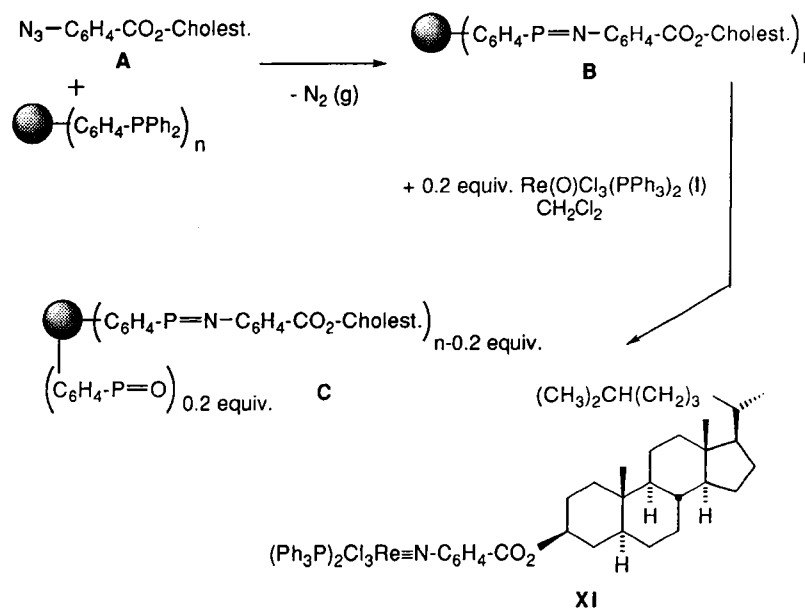

Scheme 2. Synthesis of a rhenium imido-cholesterol complex from a solid support.

imido bond, led us to investigate the possibility of using a solid-supported imido precursor for synthesizing the product Re^{V} imido compounds free from unreacted ligand. The key feature of this conceptual approach is that the Re-labeling step simultaneously cleaves the product imido complex from the polymeric support, leaving unreacted imido precursors attached to the support at the end of the reaction.

This strategy has been successfully applied to the synthesis of a cholesterol derivative as shown in Scheme 2. The 4-azidobenzoyl ester imido precursor (A) is prepared from dihydrocholesterol and 4-azidobenzoic acid, and then reacted with 2% crosslinked polystyrene-triphenylphosphine to form the solid supported phosphinimine (B). The reaction of B with I takes place in CH_2Cl_2 at ambient temperature, producing the green imido product XI, isolated in 95% yield after simple filtration to remove the unused resin C.

In conclusion, we have demonstrated that complexes containing metal imido bioconjugates are compatible with common organic functional groups, are easily prepared in high yields from acylated arylhydrazine, methoxylamine and phosphinimine precursors, are stable against hydrolysis, can be prepared in high yields at the tracer level, and by solid phase synthesis. The further development of solid supported organoimido precursors for synthesizing ^{188}Re radiopharmaceuticals in a clinical environment are currently in progress. The successful implementation of this methodology can potentially lead to simple "instant-kits" for preparing radiopharmaceuticals targeted for the low-capacity receptor sites on certain cancer cells, which will enable their treatment by radiotherapy.

Acknowledgments

J. B. A. thanks the donors of the Petroleum Research Fund, administered by the ACS, for partial support of

this research. K. A. H. and K. C. O. thank the Department of Energy OHER and Dr. Russ Knapp of ORNL for providing the $^{188}\text{W}/^{188}\text{Re}$ generator.

References

1. a) Jurisson, S., Berning, D., Jia, W., Ma, D.: Coordination Compounds in Nuclear Medicine. *Chem. Rev.* **93**, 1137 (1993). b) Eckelman, W. C.: Radiolabeling with Technetium-99m to Study High-Capacity and Low-Capacity Biochemical Systems. *European. J. Nucl. Med.* **22**, 249 (1995).
2. Nicolini, M., Bandoli, G., Mazzi, U., Eds.: *Technetium and Rhenium in Chemistry and Nuclear Medicine*, **4**, SGE Ditoriali: Padova, 1995. b) Hashimoto, K., Yoshihara, K.: Rhenium Complexes Labeled with $^{186,188}\text{Re}$ for Nuclear Medicine. *Top. Curr. Chem.* **176**, 275 (1995).
3. Mirzadeh, S., Knapp, F. F., Jr.: Biomedical Radioisotope Generator Systems. *J. Radioanal. Nucl. Chem.* **203**, 471 (1996).
4. Wigley, D. E.: Organoimido Complexes of the Transition Metals. *Prog. Inorg. Chem.* **42**, 239 (1994).
5. Chatt, J., Dilworth, J. R.: Novel Routes to New Organoimido (Organonitrene) Complexes of Molybdenum, Rhenium, and Osmium. *J. Chem. Soc., Chem. Commun.* **549** (1972).
6. a) Chatt, J., Dilworth, J. R., Leigh, G. L.: Some Alkylimido- (or Alkylnitrene) Complexes of Rhenium. *J. Chem. Soc. (A)*, 2239 (1970). b) Rochon, F. D., Melanson, R., Kong, P. C.: Synthesis and Crystal Structures of (Phosphine)technetium(V) Complexes with Phenylimido and Phenyl diazenido Ligands Using the Precursor PhNHNHCOCH_3 . *Inorg. Chem.* **34**, 2273 (1995).
7. Lisic, E. C., Mirzadeh, S., Knapp, F. F., Jr.: Synthesis of Carrier-Free Rhenium-188(V) DMSA Using Triphenyl Phosphine as a Facile Reducing Agent. *J. Labeled Compd. Radiopharm.* **33**, 65 (1993).
8. Arterburn, J. B., Fogarty, I. M., Hall, K. A., Ott, K. C., Bryan, J. C.: Functionalized Organoimidorhenium(V) Complexes as Potential Radiopharmaceuticals: Syntheses of Glycine Derivatives and the Structure Determination of a Rhenium Analogue of Chlorambucil. *Angew. Chem. Int. Ed. Engl.* **35**, 2877 (1996).
9. Sloan, O. D., Thornton, P.: The First Chelating Imido Complex: The Reaction of $\text{ReOCl}_3(\text{PPh}_3)_2$ with Anthranilic Acid. *Polyhedron* **7**, 329 (1988).

Stability of the Four 2-(*p*-nitrobenzyl)-*trans*-CyDTPA ^{88}Y Complexes*

By C. Wu¹, Martin W. Brechbiel^{1,**}, Otto A. Gansow¹, H. Kobayashi², J. Carrasquillo² and I. Pastan³

¹ Radioimmune and Inorganic Chemistry Section, Radiation Oncology Branch, NCI

² Dept. of Nuclear Medicine, CC

³ Laboratory of Molecular Biology, NCI, NIH, Bethesda, MD 20892-1002, USA

(Received December 10, 1996; accepted in revised form March 26, 1997)

*Yttrium / Antibodies / Radioimmunotherapy /
Chelates / Stereochemistry*

Summary

The unusual stereochemical influence on *in vivo* stability of the two C-Functionalized cyclohexyl diethylenetriamine-*N,N,N',N'',N'''*-pentaacetic acid (CyDTPA) chelating agents, (CHX-A, CHX-B), recently reported warranted further investigation to determine why such differences in configuration produce such striking effects on the stability of the Yttrium complex. To this end, all four individual component stereoisomers of CHX-A and CHX-B were synthesized for a detailed investigation into their chelation chemistry. Results of transchelation measurements, serum stability studies, and *in vivo* femur deposition measurements with ^{88}Y indicate that the ^{88}Y -CHX-A chelates are significantly more stable, *in vitro* and *in vivo*, than the ^{88}Y -CHX-B complexes. Additionally, significant difference *in vivo* between the ^{88}Y complexes formed from the component enantiomeric ligands were observed.

Introduction

Use of radiolabeled monoclonal antibodies (mAbs) for the diagnosis and therapy of malignancies continues to receive attention [1]. A variety of metallic radionuclides have been employed to expand the choices of emission characteristics and half-lives for diagnostic (γ and β^+ emitters) and therapeutic (β^- and α emitters) applications [2, 3].

We had previously reported the synthesis of the C-functionalized cyclohexyl diethylenetriamine-*N,N,N',N'',N'''*-pentaacetic acid (CyDTPA) chelating agents, CHX-A and CHX-B DTPA (Fig. 1), their evaluation for *in vivo* stability with ^{212}Bi , and that both ligands were excellent at sequestering Bismuth radionuclides [4–6]. However, we later reported an unexpected result upon evaluation of these two ligands with ^{88}Y . The ^{88}Y -CHX-A complex, linked to mAb B3, was found to be equivalent to the ^{88}Y -1B4M-DTPA while the ^{88}Y -CHX-B complex, under the same conditions, was remarkably unstable both *in vitro* and *in vivo* [7].

Clearly, since CHX-A and CHX-B are diastereomers, different chemical properties were to be expected and were even relied upon for the isolation

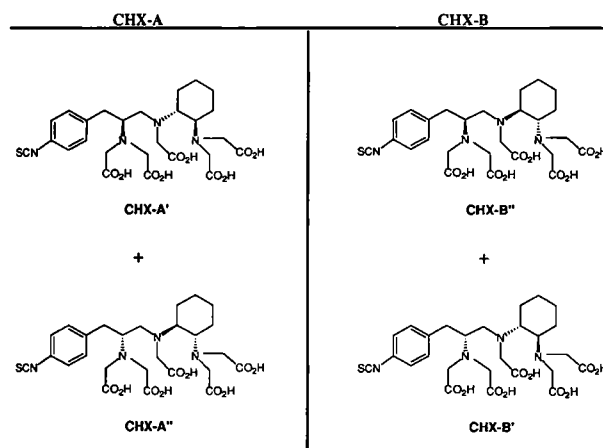

Fig. 1. Structure of the C-functionalized CyDTPAs, CHX-A DTPA and CHX-B DTPA, and their constituent enantiomers CHX-A', -A'', -B', -B''.

of the two compounds. However, large differences in *in vivo* stability for complexing ^{88}Y while being found equivalent for complexing ^{212}Bi in an active biological milieu prompted further investigation of these ligands.

Having observed that stereochemistry could be a significant variable effecting *in vivo* complex stability, some concern was expressed that even using pairs of enantiomers, such as CHX-A itself, could be yet masking some additional, subtle level of stability, or instability, that should be resolved. To eliminate all doubt as to the results obtained from study of the stability of the Yttrium complexes, stereospecific synthesis and evaluation of each of the four stereoisomers that comprise CHX-A and CHX-B DTPA's was proposed.

Herein, we report the correlated results for the first evaluation of the ^{88}Y complexes of the four stereoisomers of the C-functionalized CHX-A and CHX-B DTPA's, their individual serum stability, transchelation, and *in vivo* stability as determined by ^{88}Y deposition at the femur of mice.

Experimental

Reagents

All chemicals and solvents were purchased from either Fluka, Sigma, or Aldrich. The (*l*)-*p*-nitrophenylalanine was obtained from Research Organics while

* Presented at the Symposium on Radiochemistry and Radioimmunotherapy, Orlando, Florida, USA, August 1996.

** Author for correspondence.

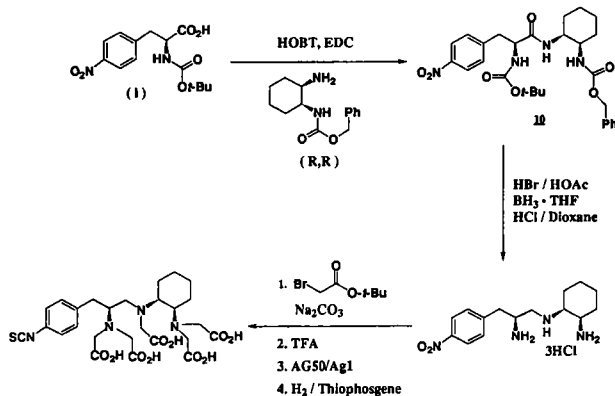

Fig. 2. Stereospecific synthesis of CHX-A'-DTPA.

the (*d*) was purchased from Bachem (CA). The *trans*-(R,R)- and (*S,S*)-1,2-diaminocyclohexanes were purchased from Fluka. Production of mAb B3 has been described in detail elsewhere [8]. ^{88}Y (YCl_3 in 0.1 M HCl) was obtained for Los Alamos National Laboratory.

Ligand synthesis and conjugation

Appropriate permutation of reagents was applied to the syntheses of the component enantiomers of the CHX-A and CHX-B DTPA's (CHX-A', -A'', -B', -B'') as depicted in the general synthesis scheme (Fig. 2). All syntheses were performed as previously reported in the literature for the LRR or CHX-A'-DTPA and were fully characterized [5].

In brief as a general example, synthesis of CHX-A'-DTPA (Fig. 2) was performed by diimide coupling of chiral carbamate protected *p*-nitrophenylalanine with the mono-carbamate protected chiral diamine. This amide was then deprotected with 33% HBr/Acetic acid (Fluka) and the resulting diamine reduced with diborane. The crude triamine reduction product was alkylated directly with *tert*-butyl bromoacetate. After ester cleavage with trifluoroacetic acid, the product was isolated by preparative HPLC and purified by anion-exchange chromatography. The aryl nitro group was hydrogenated and the aniline converted to an isothiocyanate by treatment with thiophosgene. A detailed report on the syntheses and purification has been accepted for publication [9].

The mAb B3 was concentrated to ca. 5 mg/mL and dialyzed into 0.1 M HEPES, 0.15 M NaCl, pH 8.5. The mAb solutions were then conjugated to each of the four enantiomers, respectively, and purified as previously described [10]. The average number of chelates per antibody for each enantiomer was determined to range between 1.5–2.0 for the four preparations [11].

Radiolabeling of B3-CHX-DTPA conjugates

Carrier free ^{88}Y (5 mCi) was first purified by ion-exchange chromatography (Re.Spec resin, EiChrom,

Inc.). In brief, stock solution was mixed with an equal volume of conc. HNO_3 and heated to dryness. The activity was dissolved in 2 M HNO_3 and passed through the resin. The fractions containing the ^{88}Y were collected, heated to dryness, taken up in 0.1 M HNO_3 and used for radiolabeling. The pH of the ^{88}Y solution was adjusted to ca. 6.0 with 3 M NH_4OAc and the B3 conjugate was added. After incubating for 30 min, the radiolabeled protein preparation was purified by HPLC using a TSK-3000 column eluting with PBS (pH 7.2, 0.1 M) at 1.0 mL/min. Yields were 85–90% for all four CHX isomers conjugated to B3. Specific activity for the four preparations ranged from 1.5–1.6 mCi/mg. Immunoreactivity of each preparation was determined by described methods [12].

Serum stability

The *p*-NO₂-Bz form of the CHX-A', A'', B', B'' DTPA isomers were labeled with ^{88}Y and their serum stability was evaluated over 17 days. Briefly, 25 μL of each stock ligand solution (4×10^{-4} M) were mixed with 55–60 μCi of ^{88}Y in 0.1 M HNO_3 , and the pH was adjusted to 5.5–6.5 with 3 M NH_4OAc . The reaction mixture was incubated at 37°C for 30 min. The complexes were purified by Chelex-100 resin (Bio-Rad, 3 \times 15 mm), eluted from the resin with H₂O (0.5 mL), and diluted to 1.0 mL. In every case, labeling efficiencies were $\geq 90\%$.

Aliquots (100 μL) of each ^{88}Y -labeled ligand stock solution (1.0×10^{-5} M) were then mixed with 9.9 mL of normal human serum (final concentration 1.0×10^{-7} M), passed through a sterile 0.22 μm filter (Millipore Co., Bedford, MA), aliquoted (0.8 mL) into 12 sterile culture tubes and incubated at 37°C in a CO₂-enriched atmosphere (5% CO₂).

The percentage of dissociated ^{88}Y was assessed by paper chromatography (Whatman No. 1) using PBS as the mobile phase. All ^{88}Y -labeled ligands showed R_f values ca. 1.0, whereas in the control experiments, less than 1% of free activity migrated above the top half of the paper ($R_f > 0.5$).

Transchelation

Reaction mixtures were prepared by mixing appropriate amounts of each ^{88}Y labeled B3 conjugate prepared above such that the concentration of components was 1×10^{-7} M for the chelate, 0.01 M in DTPA, and 1 mg/mL in human IgG (carrier protein to prevent non-specific adsorption of B3), pH 5.0 (0.1 M NH_4OAc) or 7.2 (0.1 M HEPES). The mixtures were sterilized by filtering them (0.22 μm filters) into sterile culture tubes which were then tightly capped, and incubated in a 37°C water bath.

The percentage of ^{88}Y transchelated to DTPA from each ^{88}Y labeled B3-CHX-DTPA isomer was measured by using size exclusion HPLC (7.8 mm \times 30 cm, TosoHaas, Japan) with elution of PBS at 1.0 mL/min.

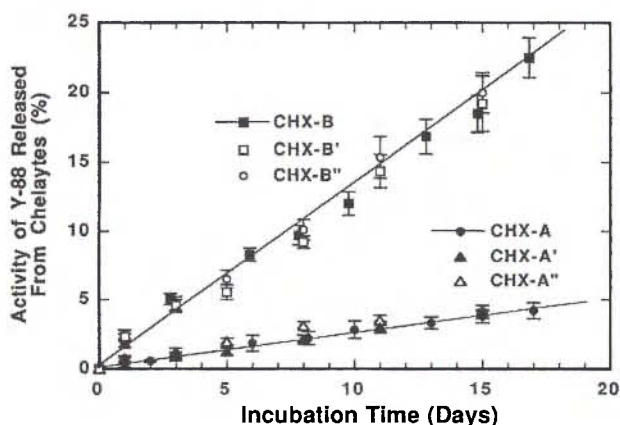

Fig. 3. Serum stability of ⁸⁸Y-CHX-DTPA complexes.

Biodistribution (Femur deposition)

Non-tumor bearing athymic mice were given i.v. 1–2 μ Ci of the ⁸⁸Y-CHX-DTPA preparations (10 mice per time point). The mice were sacrificed (24, 48, 96, and 168 h) and a modification of the reported method was applied for determining uptake of ⁸⁸Y in cortical bones [6]. In brief, a femur was removed from each, broken longitudinally, incubated with PBS for 30 min and then washed again with PBS. The bone was then washed with PBS/10% SDS for 1 hr at 56°C, centrifuged, and then washed again with PBS. The activity in the bone was counted after being blotted dry and weighed to determine percent injected dose per cortex of the bone.

Results and discussion

Synthesis of the four stereoisomers (Fig. 2) was largely unremarkable as the chemistry employed has been described in detail elsewhere [5]. A point of interest concerning a consistent difficulty encountered in the BH₃ reductions was a tendency for reduction of the aryl nitro group to the aniline. This complication could be minimized by careful titration with BH₃, but not eliminated, and as such, occasionally resulted in incomplete reduction of the amide. Thus, the triamines were not isolated, but rather directly alkylated, with purification occurring at the pentaacetic acid stage for each stereoisomer.

Determination of serum stability of the ⁸⁸Y labeled stereoisomers CHX-A', -A'', -B', B'' revealed no significant differences between the complexes formed from the enantiomeric pairs and the corresponding racemate (Fig. 3). The results essentially reproduced and confirmed the earlier report [7] that the ⁸⁸Y-CHX-B complex was significantly more unstable in serum as compared to the ⁸⁸Y-CHX-A complex for both enantiomers and racemates.

Somewhat more interesting were the results from the transchelation experiments wherein each ⁸⁸Y complex was challenged with a large excess of DTPA

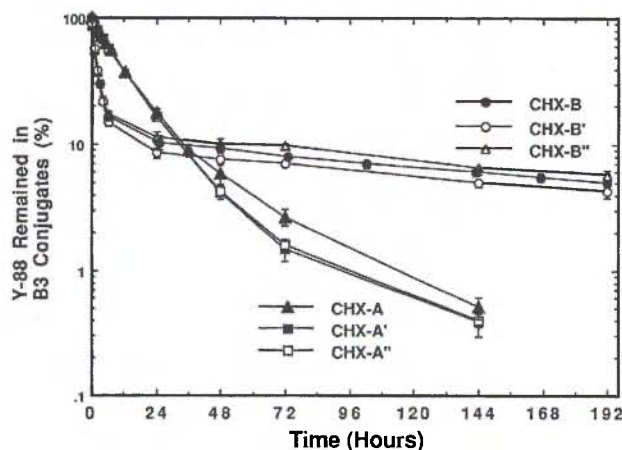

Fig. 4. Transchelation of ⁸⁸Y from ⁸⁸Y-CHX-DTPA monoclonal antibody B3 conjugates.

(Fig. 4). At pH 7.2 this reaction was too slow (<0.5% per 24 h) to be relevant when applied to the topic of relatively short-lived radioisotopes. To obtain results during a meaningful time frame, the experiment was conducted at pH 5.0. Again, the trend of the ⁸⁸Y-CHX-B complex being less stable, (ca. 85% loss of ⁸⁸Y after 12 h) than the ⁸⁸Y-CHX-A complex (ca. 85% loss of ⁸⁸Y after 24 h) was observed and as before for serum stability, the results for the individual ⁸⁸Y labeled enantiomers were essentially identical to the results for the racemate. While small differences in rate could be suggested between enantiomers, these were relegated to being due to experimental error. However, a curious result that continues to be studied was the biphasic rate of transchelation observed during the study for all of the compounds. Additionally, after rapidly losing 90% of the complexed ⁸⁸Y by 24 h, the ⁸⁸Y-CHX-B complexes appear to be rather stable for the remaining fraction of the complex as compared to the ⁸⁸Y-CHX-A. At this time, no explanation is readily available and this observation continues to be studied.

A striking result was obtained upon *in vivo* evaluation of the ⁸⁸Y labeled B3 conjugates (Fig. 5). The femur was chosen as the most critical part of the body to evaluate for ⁸⁸Y deposition due to the lanthanides and Yttrium being bone-seekers when released *in vivo* [12]. While the general trend of the ⁸⁸Y-CHX-B complexes being less stable than the ⁸⁸Y-CHX-A complexes was observed, resolution of significant differences between the ⁸⁸Y labeled conjugates was clearly obtained. A large difference was readily observed between the ⁸⁸Y-CHX-B' and ⁸⁸Y-CHX-B'' complexes after 24 h which continued to increase throughout the time course of the experiment with the ⁸⁸Y-CHX-B' conjugate being least stable of all. Of greatest importance was the small, but significant difference ($p < 0.05$, Student T-Test) recorded for the ⁸⁸Y-CHX-A'' versus the ⁸⁸Y-CHX-A' conjugate, wherein the former was found to be slightly more stable than the latter, consistently with the lowest

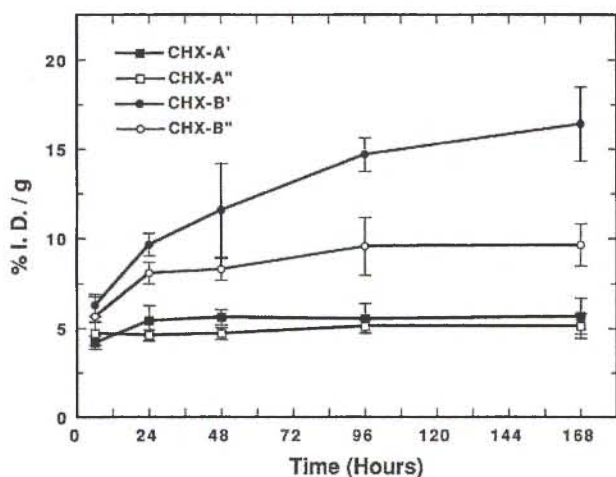

Fig. 5. ^{88}Y bone uptake from ^{88}Y -CHX-DTPA monoclonal antibody B3 conjugates in mice.

deposition of ^{88}Y to bone. This experiment was repeated for two time points for the two ^{88}Y -CHX-A enantiomers with a near identical result being obtained.

The significance of such a result is of paramount importance and implies that if one chooses the proper stereochemistry, the geometry of the coordination sphere can be optimized to obtain better chelating agents. Use of chelating agents for radioimmunotherapy and imaging must meet the minimum requirements of kinetic and thermodynamic stability *in vivo*. Failure to meet this pre-requisite leads to *in vivo* dissociation of the isotope and its subsequent deposition into organs which contributes to toxicity. These results demonstrate that ligand stereochemistry is a factor that should be considered in the design of new bifunctional chelating agents for Nuclear Medicine applications.

Conclusions

Ligand stereochemistry, largely discounted as a factor in the stability of polyaminocarboxylate ligands used for radioimmunotherapy and therapy, was found to be quite relevant to the stability of the four configurations of the C-functionalized CHX-DTPA's. To the best of our knowledge, differences in complex stability between enantiomeric ligands has not been reported in the literature and implies that the metal ion itself exerts a stereochemical influence to produce complexes that are inequivalent in a biological milieu. The limitations of serum stability and transchelation experiments were demonstrated by the inability of these methods to re-

cord the results comparable to those obtained via biodistribution.

References

1. Proceedings of the Sixth Conference on Radioimmunodetection and Radioimmunotherapy of Cancer, In: *Tumor Targeting*, 2, 127 (1996) (A. Epenetos, ed.), (Entire Journal Issue).
2. Srivastava, S. C., Mease, R. C.: Progress in Research on Ligands, Nuclides and Techniques for Labeling Monoclonal Antibodies. *Nucl. Med. Biol.* **18**, 589 (1991).
3. Jankowski, K. J., Parker, D.: Diagnosis and Therapy with antibody Conjugates of Metal Radioisotopes. In: *Advances in Metals in Medicine, Vol. 1* (M. J. Abrams, B. A. Murrer, eds.) JAI Press Inc. 1993, p. 29.
4. Brechbiel, M. W., Pippin, C. G., McMurry, T. J., Milenic, D., Roselli, M., Colcher, D., Gansow, O. A.: An Effective Chelating Agent for Labeling of Monoclonal Antibody with ^{212}Bi for α -Particle Mediated Radioimmunotherapy. *J. Chem. Soc., Chem. Commun.*, 1169 (1991).
5. Brechbiel, M. W., Gansow, O. A.: Synthesis of C-Functionalized Derivatives of *trans*-Cyclohexyldiethylenetriaminepenta-acetic Acid for Labelling of Monoclonal Antibodies with the ^{212}Bi Alpha-particle Emitter. *J. Chem. Soc., Perkin Trans. 1*, 1173 (1992).
6. Huneke, R. B., Pippin, C. G., Squire, R. A., Brechbiel, M. W., Gansow, O. A., Strand, M.: Effective α -Particle-mediated Radioimmunotherapy of Murine Leukemia. *Cancer Res.* **52**, 5818 (1992).
7. Camera, L., Kinuya, S., Garmestani, K., Wu, C., Brechbiel, M. W., Pai, L., McMurry, T. J., Gansow, O. A., Pastan, I., Paik, C. H., Carrasquillo, J. A.: Evaluation of the Serum Stability and *In Vivo* Biodistribution of the 2-(p-isothiocyanatobenzyl)-cyclohexyl-DTPA (CHX-DTPA) and Other Ligands for Yttrium-Labeling of Monoclonal Antibodies. *J. Nucl. Med.* **35**, 882 (1994).
8. Pastan, I., Lovelace, E. T., Gallo, M. G., Rutherford, A. V., Magnani, J. L., Willingham, M. C.: Characterization of Monoclonal antibodies B1 and B3 That React with Mucinous Adenocarcinomas. *Cancer Res.* **51**, 3781 (1991).
9. Wu, C., Kobayashi, H., Sun, B., Yoo, T. M., Paik, C. H., Gansow, O. A., Carrasquillo, J. A., Pastan, I., Brechbiel, M. W.: Stereochemical Influence on the Stability of Radio-Metal Complexes *in Vivo*. Synthesis and Evaluation of the Four Stereoisomers of 2-(p-nitrobenzyl)-*trans*-CyDTPA. *Bioorg. Med. Chem.* (in press).
10. Mirzadeh, S., Brechbiel, M. W., Atcher, R., Gansow, O. A.: Radiometal Labeling of Immunoproteins: Covalent Linkage of 2-(4-Isothiocyanatobenzyl)diethylenetriaminepenta-acetic Acid Ligand to Immunoglobulin. *Bioconjugate Chem.* **1**, 59-65 (1990).
11. Pippin, C. G., Parker, T. A., McMurry, T. J., Brechbiel, M. W.: Spectrophotometric Method for the Determination of a Bifunctional DTPA ligand in DTPA-Monoclonal Antibody Conjugates. *Bioconjugate Chem.* **3**, 342-345 (1992).
12. Camera, L., Kinuya, S., Pai, L. H., Garmestani, K., Brechbiel, M. W., Gansow, O. A., Paik, C. H., Pastan, I., Carrasquillo, J. A.: Pre-Clinical Evaluation of ^{111}In -Labeled B3 Monoclonal Antibody: Biodistribution and Imaging Studies in Nude Mice Bearing Human Epidermoid Carcinoma Xenografts. *Cancer Res.* **53**, 2834-2839 (1993).
13. Durbin, P. W.: Metabolic Characteristics within a Chemical Family. *Health Phys.* **2**, 225-238 (1960).

In vitro* Studies Using the Alpha-Emitter ^{212}Bi : Development of Therapy for Microscopic Carcinoma

By J. Rotmensch^{1,**}, J. L. Whitlock¹, J. L. Schwartz² and J. J. Hines¹

¹ Department of Obstetrics and Gynecology, University of Chicago, Chicago, Illinois, USA and

² Department of Radiation Oncology, University of Washington, Seattle, Washington, USA

(Received December 10, 1996; accepted in revised form October 15, 1997)

Alpha emitter ^{212}Bi / Radiotherapy / Multicellular spheroid / Radiation dose / Microscopic carcinoma

Summary

We have been investigating the use of the alpha-emitting radionuclide ^{212}Bi against microscopic carcinoma. Our *in vitro* studies show that ^{212}Bi is 2 to 4 times more effective in eradicating microscopic cells grown in monolayer or multicellular spheroid. Autoradiographs show that ^{212}Bi diffuses within the spheroids by 2 hours after exposure. There was no difference in cell kill if cells were grown in monolayer or 100 μm and 800 μm spheroids. From our study, ^{212}Bi appears to be a suitable candidate to investigate for clinical use against microscopic carcinoma.

Introduction

Alpha (α)-emitting radionuclides are being investigated for therapy against microscopic cancer [1]. This class of radionuclides have properties that make them attractive in that it is densely ionizing, delivers high-LET radiation, and its effect is not limited by the presence of oxygen. The radionuclide we are interested is Bismuth-212 (^{212}Bi). It is generated from the decay of Thorium-228 to Lead-208. In its decay 95% of the energy is derived from emission of α -decay [2].

Prior to testing ^{212}Bi in the clinical setting, its effect against cells grown in an *in vitro* system needs investigation. Previous *in vitro* studies have shown α -emitting radionuclides to increase killing compared to X-rays when cells are grown in monolayer [3]. However, in clinical situations microscopic carcinoma can be defined either as no evidence of visible disease or as the presence of multicellular clusters of cells. To simulate the latter situation, a model can be used whereby cells are grown as spheroids [4]. Since our intention is to develop ^{212}Bi for therapy against microscopic carcinoma, in this study we investigated its effect against killing microscopic cells grown either in monolayer or in spheroids.

Materials and methods

Cell lines

Two cell lines were used: a Chinese hamster fibroblast cell line (V-79) and a human ovarian epithelial carci-

noma cell line, (NIH:OVCAR-3). Cells were maintained under exponential growth conditions in α -MEM medium supplemented with 10% fetal calf serum, 100 units/ml penicillin, 100 $\mu\text{g}/\text{ml}$ streptomycin, and 2 mM L-glutamine.

Spheroid formation

To initiate spheroids, cells were cultured on plates containing 5% Bacto-agar diluted to 2% with serum-free medium at a concentration of 500,000 cells/flask. After multicellular spheroids of a minimum size were formed they were maintained until they reached a size between 10–1000 μm . This took about 2 weeks for V-79 cells and 3 weeks for NIH:OVCAR-3 cells. Just before irradiation, spheroids were sized and separated using a spheroid separation column. This column uses a nylon monofilament screen fabric to separate the spheroids based on size. The spheroids were sized and counted. Spheroids of 100 μm and 800 μm were used.

X-ray treatment

X-ray treatment of cells were done with a GE 250kvp Maxitron Unit operated at 26 mA $^\circ$ (HVL of 1.6 mm Cu) at a dose-rate of 1.11 Gy/min. Cells were exposed at room temperature and then immediately plated for survival.

^{32}P treatment

^{32}P chromic phosphate was purchased from Mallinckrodt Chemicals, St. Louis, Mo. Cells were exposed to ^{32}P chromic phosphate at room temperature in plastic tubes. To deliver a given dose the dose/ μCi was calculated and corrected for decay. The dose was calculated using the expression

$$\text{Dose (cGy)}/\mu\text{Ci-hr} = 1.33 \times 10^8 \text{ disintegrations/hr}/\mu\text{Ci} \\ \times 1.71 \text{ MeV} \times 1.61 \times 10^6 \text{ erg/MeV/vol(ml)} \\ \times 100 \text{ erg/ml-cGy} .$$

The dose was based on the assumption that the radionuclide distributed uniformly during exposure. Cells were maintained in suspension with micromag-

* Presented at the Symposium on Radiochemistry and Radioimmunotherapy, Orlando, Florida, USA, August 1996.

** Author for correspondence.

netic stirrers. After exposure cells were washed three times in phosphate-buffered saline (PBS) and then immediately plated for survival. After exposure, the medium was counted and the dose recalculated to correct for pipetting error.

^{212}Bi treatment

^{212}Bi was obtained from a generator system developed by Rotmensch *et al.* [5]. The ^{212}Pb parent was produced from a ^{224}Ra system that has been described by Atcher *et al.* [6]. After elution of ^{212}Bi , the acid was neutralized with 150 μl of 4 N sodium acetate to pH 5.0–7.4. The ^{212}Bi solution was then filtered through a 0.22 μm Millex GV filter prior to treating the cells. The filter was purged with 1 ml of distilled deionized water. The radioactivity was assayed using a 3×3 " Na(Tl) well detector. The detector output was fed into a 4096 channel multianalyzer (Davidson 4106, North Haven, Ct.). The 583 keV γ -ray for ^{208}Tl was used to determine the activity.

Cells were exposed to ^{212}Bi in suspension to deliver the desired doses over a 4 hr exposure time. The dose was determined by a method described by Schwartz *et al.* [6]. Dose/ μCi was calculated using the expression:

$$\text{Dose (cGy)}/\mu\text{Ci-hr} = 1.33 \times 10^8 \text{ dph}/\mu\text{Ci} \times 7.8 \text{ MeV} \\ \times 1.6 \times 10^{-6} \text{ erg/MeV/vol (ml)} \times 100 \text{ erg/ml-Gy}.$$

Calculation was based on the assumption that there was uniform distribution of the radionuclide during the exposure time. Exposure was terminated by washing cells three times in PBS before plating for survival determinations. After exposure the medium was counted and the dose again calculated to correct for decay and pipetting errors.

Survival measurements

Immediately after irradiation, 100–20,000 cells were plated into 10 ml of complete medium in 10×20 mm Petri plates (4 plates/dose point). Plates were stained with crystal violet and colonies greater than 50 cells scored. All experiments were run in triplicate. From the survival curves, the radiationsensitivity (D_0) was determined as described by Hall [7].

Data analysis

Regression analysis was done using Minitab data analysis software (Minitab, Inc.) [8]. Statistical significance was determined using Fisher exact test. Results were determined as mean \pm standard error of the mean for 3 to 6 independent values.

Autoradiography

At hourly intervals after exposure to ^{212}Bi , spheroids were frozen, dehydrated, and fixed in acetone. Slides

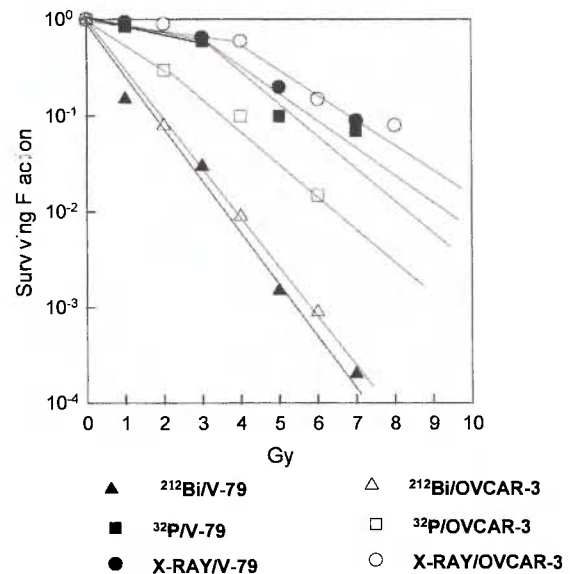

Fig. 1. Survival of cells grown in monolayer treated with X-ray, ^{32}P , and ^{212}Bi , showing increased cell kill with ^{212}Bi .

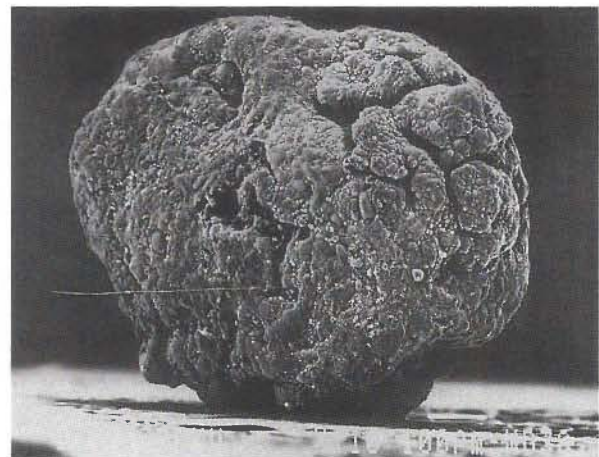

Fig. 2. Electron micrograph of spheroid used for *in vitro* studies.

containing individual thin layer sections were dipped into NTB-3 emulsion (Kodak, Rochester, N.Y.) and stained with hematoxylin and eosin [9].

Results

^{212}Bi was more effective than X-ray or ^{32}P in killing either V-79 or NIH:OVCAR-3 cells grown in monolayer. The radiosensitivity (D_0) ranged from 0.7–0.9 Gy after ^{212}Bi , 1.7–1.5 Gy after ^{32}P , and 1.8–2.2 Gy after X-ray therapies for the two cell lines (Fig. 1). There was no difference in the radiosensitivity of the two cell lines. The relative biological effectiveness was 2.2 to 2.4 times greater for ^{212}Bi compared to X-ray therapy.

Electron micrographs of the spheroids before treatment showed them to be three dimensional (Fig. 2). Treating spheroids with ^{212}Bi caused a similar effect as seen with those in monolayer. ^{212}Bi was more effective

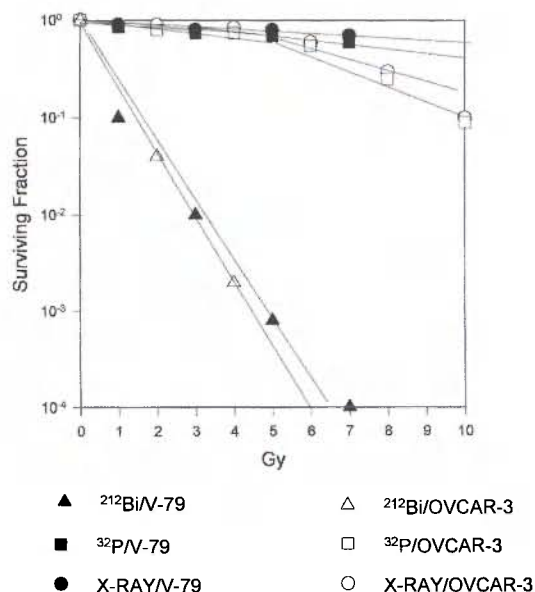

Fig. 3. Survival of cells grown in to spheroids showing increased cell kill of ^{212}Bi compared to X-ray and ^{32}P .

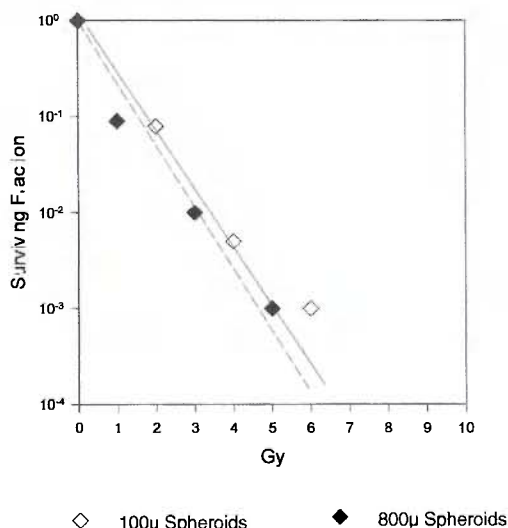

Fig. 4. Equal survival of 100 μm and 800 μm spheroids after 4 hour exposure to ^{212}Bi .

in killing spheroids than ^{32}P and X-rays. Do ranged from 0.6–0.7 Gy after ^{212}Bi therapy; 2.5–2.7 Gy after ^{32}P therapy; and 2.5–2.8 after X-ray therapy (Fig. 3). The relative biological effectiveness was 4.2 to 4.8 times greater with ^{212}Bi than X-rays. The radiosensitivity of 100 μm spheroids were similar in both cell lines. There was no difference in radiosensitivity for 100 μm and 800 μm spheroids grown from NIH:OVCAR-3 cells. Do was 0.7 Gy for both size spheroids (Fig. 4).

Autoradiographs showed that ^{212}Bi distributed throughout the spheroid within a short time. At 2 hours activity is seen homogeneously throughout a 800 μm NIH:OVCAR-3 spheroids (Fig. 5).



Fig. 5. Autoradiograph of center of 100 μm spheroid showing ^{212}Bi diffused onto cell.

Discussion

^{212}Bi appears to be a suitable candidate to investigate for therapy to eradicate microscopic cancer. Unlike the low-LET of conventional radiation used, it is high-LET and densely ionizing. It has a short half-life on only 60.6 minutes having the ability to deliver its energy to a region rapidly while minimizing exposure of normal structures.

Because of the short half-life a problem has been the production of quantities of ^{212}Bi that are clinically useful. Atcher *et al.* developed a system to generate ^{212}Bi through the decay of Radium-224 [10]. However, with the generation of large quantities of ^{212}Bi there is degradation of the support system allowing breakthrough of unwanted long-lived parent radionuclides. We have recently developed a new system based on the decay of ^{212}Bi and growth of ^{212}Pb [5]. Our belief is that this system will be more useful for clinical trials in that up to 30 mCi of ^{212}Bi has been produced with no significant radiocontamination. Since it is our intention to use the system we developed for early clinical use, this source of ^{212}Bi was used for *in vitro* studies.

Prior to proceeding to *in vivo* trials, we decided to test the effect of ^{212}Bi against microscopic disease in an *in vitro* model and compare its effect to conventional radiotherapy (X-ray and the β -emitter ^{32}P). For these studies two cell lines were chosen. Our first studies were done using the cell line V-79. This is a Chinese hamster lung fibroblast cell line. It was chosen because it has been used in many previous radiobiological studies with X-ray therapy [11]. However, since our intention is initially to treat women with adenocarcinoma of the ovary, we believed that it was more relevant to study a human ovarian adenocarcinoma. For this reason we chose the NIH:OVCAR-3 cell line. This is a well characterized human cell line that was established from ascites of a patient with adenocarcinoma of the ovary.

In our early studies the effect of ^{212}Bi against cells grown in monolayer was investigated [3]. This extrapolates to a clinical situation where there is no evi-

dence of carcinoma but a patient is at high risk for recurrence. In this circumstance, ^{212}Bi was 2 to 4 times more effective in killing cells than X-ray or ^{32}P regardless of the cell line used.

In most clinical situations, cells are not present as individual cells but as clusters of microscopic cells. Cells grown *in vitro* as spheroids may better represent this situation. Spheroids are multicellular, have cell to cell contacts and areas of necrosis [4]. The necessity for studying cells in spheroids is that the results of monolayer studies often cannot be extrapolated to multicellular spheroids. With V-79 cells different effects have been reported with X-ray for cells grown in monolayers and those in spheroids. Van Leeuwen-Stok *et al.* found treating cells with the Auger emitter ^{67}Ga single cells were more sensitive than spheroids [12]. In our study, regardless of the cell line used for spheroid formation, ^{212}Bi was 2 to 4 times more effective in eradication of the spheroids regardless if 100 μm and 800 μm spheroids were treated.

We postulate that the increased cell kill may be caused by the rapid absorption of ^{212}Bi through the spheroid. Autoradiographs of cross sections show that the activity is not only deposited on the surface but is absorbed within 2 hours. This is in contrast to assumptions made in computerized modeling of dosimetry that activity is a static process and is only on the surface of a tumor mass [13]. These modeling systems do not take into account the diffusion of activity over time.

Our earlier studies focused on the use of ^{212}Pb as a colloid of ferrous hydroxide [1]. At this time, we do not believe that this preparation is most optimal for intraperitoneal therapy. A requirement of using this route of administration in patients is that there is uniform distribution throughout the peritoneal cavity. Our preliminary *in vivo* work has showed that ^{212}Pb ferrous hydroxide does not evenly distribute but rapidly settles forming radioactive hot spots. In contrast based on our animal studies ^{212}Bi distributes evenly throughout its decay. Our initial goal is to develop the use of ^{212}Bi in as a non-specific therapy. However, the potential exists of also developing this therapy as a directed therapy by chelating it to an antibody [14].

From our studies, it appears that ^{212}Bi is a suitable candidate to further study for development of therapy

against microscopic cancer. Our future studies are aimed to determine the *in vivo* effects of ^{212}Bi . We are planning to study the distribution and associated toxicity in animal models. In addition, we are improving the method of producing this radionuclide.

References

1. Rotmensch, J., *et al.*: Development of α -emitting radionuclide lead-212 for potential treatment of ovarian carcinoma. *Am. J. Obstet. Gynecol.* **60**, 789–797 (1989).
2. Fisher, D. R.: The microdosimetry of monoclonal antibodies labeled with alpha-particles. In Schlafke, A. J., Watson, E. E.: Fourth international radiopharmaceutical symposium. US Department of Energy **1986**, 26–36.
3. Rotmensch, J., *et al.*: Comparison of short-lived high-LET α -emitting radionuclides lead-212 and bismuth-212 to low-LET X-rays on ovarian carcinoma. *Gynecol. Oncol.* **35**, 297–300 (1989).
4. Langmuir, V. K., *et al.*: The effect of antigen concentration, antibody valence and size, and tumor architecture on antibody binding in multicell spheroids. *Nucl. Med. Biol.* **18**, 754–764 (1991).
5. Rotmensch, J., Whitlock, J. L., Hines, J., Haper, P. V.: Development of a generator for the production of Bi-212. Patent pending.
6. Schwartz, J. L., *et al.*: Differential locus sensitivity to mutation induction by ionizing radiations to different LETs in Chinese hamster ovary K1 cells. *Carcinogenesis* **12**, 1721–1726 (1991).
7. Cell survival curves. In Hall, E. J.: *Radiobiology for the radiologist*. 4th ed. Philadelphia: JB Lippincott Co. **1994**, 29–73.
8. Minitab data analysis software release 7, 1989.
9. Autoradiography at the light microscopic level. Kodak Tech Bits. Eastman Kodak Company 1988.
10. Atcher, R. W., *et al.*: An improved generator for the production of ^{212}Pb and ^{212}Bi from ^{224}Ra . *Int. J. Appl. Radiat. Isot.* **39**, 283–286 (1988).
11. Langmuir, V. K., *et al.*: Dosimetry models of radioimmunotherapy. *Med. Phys.* **15**(6), 867–873 (1988).
12. Van Leeuwen-Stok, A. E., *et al.*: Gallium-67 in the human lymphoid cell line U-715: uptake, cytotoxicity and intracellular localization. *Int. J. Radiat. Biol.* **64**(6), 749–759 (1993).
13. Roeske, J. C., *et al.*: Modeling of dose to tumor and normal tissue from intraperitoneal radioimmunotherapy with alpha and beta emitters. *Int. J. Radiat. Oncol. Biol. Phys.* **19**(6), 1539–1548 (1990).
14. Kuzae, R. W., *et al.*: Bismuth-212 labeled anti-TAC monoclonal antibody: alpha particles-emitting radionuclides as modalities for radioimmunotherapy. *Proc. Natl. Acad. Sci. USA* **83**, 474 (1986).

Enhancing the Specific Activity of ^{186}Re Using an Inorganic Szilard-Chalmers Process*

By W. Jia and G. J. Ehrhardt**

University of Missouri Research Reactor Center, Columbia, Missouri 65211, USA

(Received December 10, 1996; accepted in revised form October 23, 1997)

*Szilard-Chalmers process /
High specific activity ^{186}Re / ^{186}Re production /
Radioimmunotherapy / Radiotherapy*

Summary

Conventional Szilard Chalmers experiments using unstable organometallic compounds usually fail to scale up with increased irradiation time and neutron flux. An alternative, inorganic-based, Szilard-Chalmers system involving rhenium metal films or insoluble, mixed-metal oxides, in a level of several millicuries, for enhancement of the specific activity of (n, γ) ^{186}Re and ^{188}Re is being evaluated at MURR. This system has consistently yielded enrichment factors of greater than 3 with a neutron flux of 8×10^{13} n/cm²/s for several irradiation hours.

Introduction

For a number of years, ^{186}Re has been of interest to the nuclear medicine community for use in therapeutic applications [1–5]. It is a beta-emitting radionuclide with a maximum energy of 1.07 MeV and a decay half life of 89.25 hours. It also emits a 137 keV gamma ray in 9.2% abundance suitable for evaluation of *in vivo* distribution of rhenium agents.

The principal drawback to ^{186}Re for radioimmunotherapy or receptor agent-guided radiotherapy is the production method utilizing the (n, γ) reaction in a nuclear reactor. Although the thermal and epithermal neutron cross sections for ^{185}Re are high (106 b and 1632 b, respectively), the specific activity of ^{186}Re which can be produced in a reactor such as University of Missouri Research Reactor (thermal neutron flux 4.5×10^{14} n/cm²/s) is only about 3 Curies/mg Re at end of irradiation, which is considered marginal for radioimmunotherapy at the present time. Since only a handful of reactors with higher neutron fluxes are operating in the world, methods of enhancing the specific activity of ^{186}Re by other means are desirable.

It was recently reported that no-carrier-added ^{186}Re was produced via a $^{186}\text{W}(p, n)^{186}\text{Re}$ reaction [6]. A 99.79% enriched [^{186}W]WO₃ target was irradiated with 13.6 MeV protons at a beam current of ~ 3 μA . The apparent disadvantages of this accelerator production of no-carrier-added ^{186}Re are the high production cost

and relatively low yield, which may limit this production method to only the research stage.

Conventional Szilard-Chalmers techniques, which utilize an organic Re complex as the starting material, take advantage of the ~ 6 MeV of excitation gamma energy emitted by the rhenium nucleus after thermal neutron capture to rupture organometallic bonds via the recoil energy [7–8]. This approach has been proposed and evaluated by many investigators. Cohn *et al.* [9] reported irradiating a Re compound, Cp*ReO₃ (pentamethylcyclopentadienyl rheniumtrioxide), in their reactor and observed that the activated compounds (molecules containing hot Re atoms) decomposed to water soluble perrhenate while the rest of the molecules would remain in the organic phase. The specific activity of ^{186}Re was enhanced by a factor between 400–800 with neutron irradiation at 1.5×10^{13} n/cm²/s for 10 minutes. However, a Re target of this type is not allowed to be irradiated at our facility due to the potential safety problem. Szilard-Chalmers reactions normally do not result in significant specific activity enhancement in high neutron fluxes due to the increased radioactive (gamma and fast-neutron) decomposition of non-activated metal-organic bonds. In other words, experiments using organic compounds frequently produce large enhancement of specific activity for short irradiations in low neutron fluxes, but progressively fail to deliver enhanced specific activity product as irradiation time and neutron flux are increased.

Alternative, inorganic-based, Szilard-Chalmers systems involving rhenium metal films or insoluble, mixed-metal oxides, have been investigated in our laboratories up to a level of several millicuries, for enhancement of the specific activity of (n, γ) ^{186}Re and ^{188}Re . A number of rhenium targets were prepared and evaluated in the laboratory. The yield and enrichment factor were measured for the Szilard-Chalmers effect on neutron irradiated targets to investigate the feasibility of this method of production of high specific activity ^{186}Re . The basis of this process lies in the assumption that lower oxidation states of rhenium will tend to react with oxygen to form water-soluble Re(VII) when provided with sufficient activation energy from the recoil process (which yields transient temperatures of many thousands of degrees Kelvin). Only natural rhenium targets have been used to date, as an enriched ^{185}Re target has not yet been made in

* Presented at the Symposium on Radiochemistry and Radioimmunotherapy, Orlando, Florida, USA, August 1996.

** Author for correspondence.

the proper chemical form. Use of natural rhenium target also permits comparison between enhancement factors for ^{186}Re vs. ^{188}Re . Although these factors for ^{188}Re and ^{186}Re have been relatively low (4–20), they have been reproducible. Of greater significance is the observation that scaling up from 5 second irradiations at 4×10^{13} thermal neutrons cm^2/s to 30 minute irradiations at the same flux did not significantly reduce the enhancement factor, indicating that the low enrichment factors were probably due to the poor target preparation instead of radioactive decomposition. In any event, enhancement of the specific activity of ^{186}Re by even a factor of 3–5, if it could be accomplished at high neutron flux, would be sufficient to render ^{186}Re a very attractive agent for radioimmunotherapy. The use of inorganic compounds, which in general are more resistant to radiation fields than organic or organometallic compounds, reinforces the reasonableness of this suggestion, while the utter simplicity of the process also renders it attractive.

The inorganic hot atom chemistry can be investigated with many different chemical compounds and different isotopes. In fact, a number of target samples including compounds of gold, copper, etc. have been prepared and a great diversity of methods have been used in our laboratory. This paper describes ^{186}Re enrichment with the inorganic Szilard-Chalmers process.

Experimental

Materials

Rhenium metal powders (325 mesh, 99.997% metals basis, Johnson & Matthey), Rhenium(III) chloride (F.W. 292.56, dark red powder, 99.9% metals basis, Johnson & Matthey), Rhenium(V) chloride (F.W. 363.47, dark green powder, 99.9% metals basis, Johnson & Matthey), Rhenium(VII) oxide (light yellow powder, F.W. 484.40, 99.99% metals basis, Johnson & Matthey), Rhenium silicide (ReSi_2 , F.W. 242.37, ~80 mesh powder, 99.9% metals basis, Johnson & Matthey), Rhenium(VI) oxide (ReO_3 , F.W. 236.20, purplish red powder, Johnson & Matthey), Rhenium(IV) oxide (ReO_2 , F.W. 218.24, black powder, 99.9% metals basis, Johnson & Matthey), Rhenium foil (0.25 mm thick, 99.98%, F.W. 186.20, Aldrich Chemical), Rhenium(VII) sulfide, (Re 60.6%, $\text{Re}_2\text{S}_7 \cdot \text{H}_2\text{O}$, F.W. 614.87, black powder, Johnson & Matthey), Acetone (2-propanone, >99.5%, Fisher), Magnesium chloride ($\text{MgCl}_2 \cdot 6 \text{H}_2\text{O}$, Mallinckrodt), Sodium hydroxide solution (4.95–5.05 N, standard solution, Fisher), Tin(II) chloride (Stannous chloride SnCl_2 , F.W. 189.60, 99.99+%, Aldrich Chemical), Titanium(IV) chloride (TiCl_4 , F.W. 189.71, liquid, 99.8% metals basis, Johnson & Matthey).

Target preparation

Rhenium metal film

About 0.1–1 mg of Rhenium Trioxide or Rhenium Pentoxide were weighed in a high purity quartz tube

with one end sealed. The open end of this quartz tube containing rhenium chloride was inserted into a Teflon tube which was connected to a vacuum pump. A carbon capsule (Gelman Sciences, containing activated charcoal particles) was installed in the vacuum line to trap the volatile rhenium chlorides, water and other chemicals that may potentially be collected into the system. After the vacuum pump was turned on for several minutes, the quartz tube was placed on the flame of a Bunsen burner, and a thin layer of shiny metal film was soon produced on the quartz wall. The quartz tube coated with a thin layer of silvery rhenium metal was then rinsed with water and acetone (to remove the residual rhenium chloride and soluble perrhenate) and vacuum dried. The tube was then sealed with or without vacuum using a torch.

Rhenium and titanium oxides

About 1–5 mg of Rhenium Trichloride or Rhenium Pentachloride were placed in a dry reaction vial containing a magnetic stir bar. In the fume hood, 0.5 ml of TiCl_4 (colorless liquid form, fuming and volatile) was added into the vial by pipette. The Re chloride dissolved with stirring in the TiCl_4 and the solution turned to a purple color. About 10 ml of Na_2CO_3 (mixed with 0.5 N NaOH) solution with $\text{pH} > 10$ was slowly added into the TiCl_4 solution; white fumes (presumably HCl) were released from the solution, and a precipitate of mixed hydrous TiO_2 and $\text{ReO}_2/\text{ReO}_3$ was immediately observed. The precipitate was separated from the supernatant through centrifugation, washed with de-ionized water and acetone, dried with nitrogen gas, and stored in a desiccator.

Rhenium and tin oxides

About 1 mg of Re_2O_7 was dissolved in 2–3 ml of water and to this solution was added 2–3 ml of stannous chloride solution containing about 2–3 mg of SnCl_2 . The solution was stirred and heated to $\sim 90^\circ\text{C}$ for 20 minutes and the dark mixture of Re(IV) and Tin(IV) oxides were formed. The solid precipitate was then collected in a clean test tube after separation from the supernatant, washed with water and acetone, dried with nitrogen gas, and stored in a desiccator.

Rhenium and magnesium oxides

To a sodium carbonate buffer solution at $\text{pH} = \sim 11$, solutions of ReCl_3 in acetone and MgCl_2 in water were slowly added through two pipettes. Vigorous stirring was maintained during the addition of the solutions and the formation of purple-colored colloidal Re and Mg oxides. The ratio of Re/Mg was normally kept 1:10.

1. Irradiation of Re targets

The rhenium targets were irradiated at $4\text{--}8 \times 10^{13}$ thermal neutrons/ cm^2/s for times varying from 10 min-

utes to 15 hours. For irradiation times <1 hour, samples were placed in high purity polyethylene vials and sealed at 1 atm. These vials were then placed in a polypropylene capsule which was inserted into the reflector positions through a pneumatic tube system. For irradiation times >1 hour, samples were sealed in high purity quartz vials which were then encapsulated in aluminum capsules/cans.

Irradiations using flooded aluminum cans were also performed to minimize the excessive heating during the neutron bombardment. Quartz vials were in direct contact with cooling water circulating through the holes on the aluminum wall. The temperature of quartz vials in flooded irradiation cans was maintained lower than 100°C , typically around 70°C .

2. Recovery of ^{186}Re and ^{188}Re

The irradiated rhenium targets were allowed to decay for 1 to 12 hours to minimize short-lived by-product radionuclides. The irradiation capsule (quartz ampoule or polyethylene vial) was then opened using a vial breaker or a razor. De-ionized water or organic solvents such as acetone and absolute ethanol were added to the rhenium target and the suspension mixed using a vortex device. After one or two minutes, the supernatant was separated from solid target by filtration. The radioactivity in the solvent and radioactivity remaining in the target and filter were measured using an AtomLab Dose Calibrator adjusted to the ^{188}Re setting. Aliquots of supernatant were taken and analyzed with a high resolution, high purity intrinsic Ge detector.

3. Determination of enrichment factors

A fraction of supernatant containing ^{186}Re and ^{188}Re obtained from the above procedure was then transferred into a clean polyethylene vial, and the solvent in the vial was carefully taken to dryness under a heat lamp. The vial was then heat sealed and the radioactivity of ^{186}Re and ^{188}Re was measured with a Ge detector and recorded as A_1 . A_1 was decay corrected to EOI of the first irradiation as A_{01} . After most of the activity in the vial decayed away, the vial was irradiated at the same position for the same exposure time as the first irradiation.

The radioactivity produced from the second irradiation was then measured with a Ge detector and recorded as A_2 . After A_2 was converted to A_{02} (the activity of EOI of second irradiation), A_{02} was compared with A_{01} and the enrichment factor is calculated as follows:

$$\text{Enrichment factor} = \frac{A_{01} \text{ at EOI(I)}}{A_{02} \text{ at EOI(II)}}$$

If the second irradiation produces the same amount of activity as the first irradiation, that is, $A_{02} = A_{01}$, there is no radioisotope enrichment, since it requires the

same number of cold rhenium atoms in the recovered sample to produce the same amount of activity. On the other hand, if $A_{02} < A_{01}$, there is less cold rhenium (carrier) to be activated to radioactive rhenium isotopes, hence the specific activity of radioactive rhenium is enhanced, and thus there is a radioisotope enrichment.

Results and discussion

Rhenium metal targets

Thus far, Re metal targets including Re metal powder and Re metal film (coated inside of the quartz ampoule) have been evaluated for irradiation at 4×10^{13} n/cm²/s (or higher) from 60 seconds up to three hours. Results from some experiments are shown below:

- Experiment 1** **Re metal film** freshly prepared by heat decomposition of ReCl_3 in quartz vial, vial was sealed at 1 atm.
 Irradiation: 1 hour at 3×10^{13} n/cm²/s
 Activity: 43.7% of total activity was recovered in water (assayed with AtomLab Dose Calibrator with ^{188}Re setting).
 Enrichment: ^{186}Re : 1.76 ^{188}Re : 2.46
- Experiment 2** **Re metal film** made from ReCl_3 (heat decomposition) target was aged for 48 hours in an evacuated container. High purity quartz vial, sealed under vacuum (100 Torr).
 Irradiation: 1 hour at 4×10^{13} n/cm²/s
 Activity: 20% of radioactivity as ^{188}Re was recovered in water
 Enrichment: ^{186}Re : 3.65 ^{188}Re : 3.00
- Experiment 3** **Re metal film** made from ReCl_3 (heat decomposition), target was aged for 48 hours in desiccator. High purity quartz vial, sealed at 1 atm.
 Irradiation: 1 hour at 4×10^{13} n/cm²/s
 Activity: 34.3% of activity as ^{188}Re was recovered in water
 Enrichment: ^{186}Re : 2.06 ^{188}Re : 2.09
- Experiment 4** **Re metal film** made from ReCl_3 (heat decomposition), target was aged for four weeks in a desiccator. High purity quartz vial, sealed under vacuum. Irradiation using flooded aluminum can
 Irradiation: 2 hours at 8×10^{13} n/cm²/s
 Activity: 15.08% of activity as ^{188}Re was recovered in water
 Enrichment: ^{186}Re : 3.24 ^{188}Re : 3.17

Based on the various experiments, our obser-

variations are (1) the use of rhenium metal (powder or thin film) as target materials in this type of Szilard-Chalmers reaction produced enhanced specific activity of ^{186}Re and ^{188}Re ; (2) freshly prepared rhenium metal films are not suitable for irradiation because the irradiated targets tend to dissolve in water; (3) it is necessary to apply a vacuum in encapsulating rhenium metal films in the quartz ampoules; (4) irradiation with reduced temperature by water cooling may result in better and more consistent enrichment factors. It was originally thought that fresh rhenium targets were needed to minimize the formation of an oxide layer on the metal surface, which would possibly reduce radioactivity recovered in water. It also appeared likely that we should allow air/oxygen contained in the irradiation samples (in the quartz ampoules) to promote the oxidation of Re hot atoms. However, these considerations appear to have been mistaken. The aged rhenium targets prepared under vacuum appeared to be more stable upon irradiation and resulted in higher radioisotope enrichment factors. This observation is not fully understood. Perhaps the oxygen under neutron activation conditions reacted with target non-specifically. There are a number of factors involved in the Szilard-Chalmers reaction that determine the radioisotope enrichment, among them the thickness of rhenium film (or the particle size of metal powder), oxygen level, neutron flux, reactor exposure time, temperature during the irradiation, gamma irradiation, decay time after the irradiation, and the separation method for the recovery of "hot atoms". While there is limited room for adjustment on irradiation and separation conditions, optimizing the preparation of irradiation targets seems to be the key for achieving high radioisotope enrichment factors.

Calculation of the thickness of Re metal film

A rhenium target (metal film, area of about $1\text{ cm} \times 0.5\text{ cm} = 0.5\text{ cm}^2$) was coated on the quartz wall and encapsulated in the high purity quartz vial. This target was irradiated for 60 minutes. Thermal neutron flux used was $4 \times 10^{13}\text{ n/cm}^2/\text{s}$. Radioactivities of target at EOI: ^{186}Re 22.0 μCi ; and ^{188}Re 97.6 μCi . Thus, calculated mass of rhenium metal present in the target based on the activity, irradiation time and flux is $\sim 0.015\text{ mg}$ or 15 μg . Since the density of rhenium metal is $20.53\text{ g/cm}^3 = 20530\text{ mg/cm}^3$, and area of rhenium film estimated is 0.5 cm^2 , the thickness of rhenium film should be $1.5 \times 10^{-6}\text{ cm}$, or 150 \AA (\AA = Angstroms). As the atomic radius of Re is 1.28 \AA , diameter is 2.56 \AA , therefore, this 150 \AA thickness represents ~ 59 Re atoms.

Rhenium oxide targets

Various mixed rhenium oxides have been purchased (from Johnson and Matthey) or prepared; they are listed with their physical appearance in Table 1.

Table 1. Mixed rhenium and other metal oxides

Re compounds	Proposed formula	Physical appearance
Re dioxide	ReO_2	powder, black
Re trioxide	ReO_3	powder, dark red
Re-Mg oxides	$\text{ReO}_3 \cdot x\text{H}_2\text{O} \cdot \text{MgO}$ $\cdot y\text{H}_2\text{O}$	powder, purple
Re-Ti oxides	$\text{ReO}_3 \cdot x\text{H}_2\text{O} \cdot \text{TiO}_2$ $\cdot y\text{H}_2\text{O}$	powder, green
Re-Sn oxides	$\text{ReO}_2 \cdot x\text{H}_2\text{O} \cdot \text{SnO}_2$ $\cdot y\text{H}_2\text{O}$	powder, brown
Re sulfide	$\text{Re}_2\text{S}_7 \cdot \text{H}_2\text{O}$	powder, dark brown
Re silicide	ReSi_2	powder, black

ReO_2 and ReO_3

No significant radioactivities were recovered in water due to the relatively large particle sizes (100–200 mesh).

Re-Mg and Re-Ti oxides

The results of the experiment using this preparation are summarized in Table 2.

Five different rhenium mixed oxide samples were prepared and irradiated at $4 \times 10^{13}\text{ n/cm}^2/\text{s}$ for 60 seconds. Experimental results are shown in Tables 3, 4, 5.

Re-Sn oxides

About 1 mg of $\text{ReO}_2/\text{SnO}_2$ (1:1 ratio) mixture was irradiated at a thermal neutron flux of $4 \times 10^{13}\text{ n/cm}^2/\text{s}$ for 30 minutes. The irradiated sample was washed with 5 ml deionized water and 23.3% of the activity was collected in the water. Enrichment factors obtained from the second irradiation of the water sample were: 2.09 for ^{186}Re ; and 2.00 for ^{188}Re .

$\text{Re}_2\text{S}_7 \cdot \text{H}_2\text{O}$

Results are summarized as follows:

Experiment 1

Target: 0.95 mg of $\text{Re}_2\text{S}_7 \cdot \text{H}_2\text{O}$
 Irradiation: $4 \times 10^{13}\text{ n/cm}^2/\text{s}$ for 10 minutes
 Activity: 495 μCi assayed with AtomLab Dose Calibrator
 Recovery: 12.4%
 Solvent: de-ionized water, 5 ml
 Enrichment: ^{186}Re 4.06 ^{188}Re 3.88

Experiment 2

Target: 1 mg of $\text{Re}_2\text{S}_7 \cdot \text{H}_2\text{O}$
 Irradiation: $4 \times 10^{13}\text{ n/cm}^2/\text{s}$ for 20 minutes
 Activity: $\sim 1\text{ mCi}$ assayed with AtomLab Dose Calibrator
 Recovery: 41.8%
 Solvent: acetone, 5 ml
 Enrichment: ^{186}Re 1.48 ^{188}Re 1.88

Table 2. Szilard-Chalmers experiment (Re-Mg oxides, 2 mg, 30 minutes irradiation)

Sample	Volume (μl)	First irradiation (μCi)		Second irradiation (μCi)		Enrichment factors	
		^{186}Re	^{188}Re	^{186}Re	^{188}Re	^{186}Re	^{188}Re
I	150	45.26	224.10	10.02	71.36	4.52	3.14
II	150	35.72	171.16	7.58	60.20	4.71	2.84
III	150	6.91	34.03	1.79	12.45	3.86	2.73

Table 3. Re targets used in the experiment

Sample ID	Mass (mg)	Color of samples	Starting material
A	3.5	purple	$\text{ReCl}_5 + \text{MgCl}_2$
B	2.8	gray/light green	$\text{ReCl}_5 + \text{MgCl}_2$
C	11	gray/light purple	$\text{ReCl}_5 + \text{TiCl}_4$
D	6.9	gray	$\text{ReCl}_5 + \text{TiCl}_4$
E	14.8	green	$\text{ReCl}_5 + \text{TiO}_2$

Table 4. ^{188}Re activity recovered in the experiment

Sample ID	Activity (μCi)	Supernatant (μCi)	Washed target (μCi)	Recovery (%)
A	134.8	82.0	54.5	60.08
B	75.5	54.0	17.4	71.5
C	72.8	56.3	23.4	77.3
D	80.9	48.9	32.7	60.4
E	28.6	4.0	25.0	14.0

Table 5. Enrichment factor for ^{188}Re

Sample ID	First irradiation (μCi)	Second irradiation (μCi)	Enrichment factor
A	90.78	12.04	7.54
B	66.25	15.63	4.23
C	15.49	3.30	4.69
D	9.40	2.55	3.68
E	2.75	2.13	1.29

Preparation of homogeneous mixed oxide solids from solution appears to be much more difficult than anticipated. None of the mixed oxides prepared and evaluated in our laboratory were ideal samples. The rate of precipitation for each metal oxide, Re, Mg, Sn, or Ti in aqueous solution is different, and thus, the solid oxides obtained from solution were usually non-homogeneous mixtures of two or more individual hydrous oxides, for instance, $\text{ReO}_3 \cdot x \text{H}_2\text{O}$ - $\text{MgO} \cdot y \text{H}_2\text{O}$, instead of ReO_3 - MgO or MgReO_4 . The preparation of the latter compound, MgReO_4 , required high temperature and pressure. A " MgReO_4 " sample was obtained from Johnson and Matthey (a special preparation upon our request), but unfortunately, this compound, magnesium rhenate, was actually a perrhenate

Re(VII) which readily dissolved in water and other solvents such as acetone and ethanol.

Despite the difficulties in preparing ideal rhenium oxide targets, all the samples prepared using "wet chemistry" demonstrated high activity recovery and some enrichment, which render them promising materials for the Szilard-Chalmers process.

Conclusions

Both rhenium metal film and mixed oxides are considered potentially feasible targets for the production of high activity as well as high specific activity ^{186}Re . The experiments using rhenium metal film and mixed rhenium oxides were scaled up with elevated neutron flux and longer exposure time (8×10^{13} n/cm²/s for two hours). It appeared that rhenium metal film yielded higher enrichment factors than the rhenium oxides.

The key to this process seems to lie in preparing an appropriate inorganic rhenium target material which can be irradiated, leached to remove "hot", water-soluble ^{186}Re , and then filtered to remove the carrier rhenium and recover the isotopically-enriched target for re-use. The preparation of aged and thus chemically stable rhenium metal film is vital for the consistency and reproducibility of the process. Mixed oxides containing Re and other metals appeared to yield high radioactivity (typically above 20%) in the supernatant and achieved significant enrichment factors ranging from 2 to 10. Due to the current experimental conditions, optimal procedures for preparing homogeneously mixed rhenium and other metal (Ti, Mg, or Sn) oxides have not been developed, and thus, consistent results in terms of recovery of radioactivity and radioisotopic enrichment with the same or increased neutron flux have not been obtained.

In summary, the inorganic Szilard-Chalmers reaction using rhenium metal film or mixed rhenium oxides as target materials has the potential to provide significantly higher specific activities of $(n,\gamma)^{186}\text{Re}$ for radioimmunotherapy and other nuclear medicine applications. The optimization of target preparation is the key to the enhancement of radioisotopic enrichment.

References

1. Mirzadeh, S., Schenter, R. E., Callahan, A. P., Knapp, Jr., F. F.: Production Capabilities in U.S. Nuclear Reactors for

- Medical Radioisotopes. U.S. Department of Energy, Nov. 1992.
2. Volkert, W. A., Goeckeler, W. F., Ehrhardt, G. J., Ketring, A. R.: Therapeutic Radionuclides: Production and Decay Property Considerations. *J. Nucl. Med.* **32**, 174–185 (1991).
3. Schubiger, P. A., Alberto, R., Smith, A.: Vehicles, Chelators, and Radionuclides: Choosing the “Building Blocks” of an Effective Therapeutic Radioimmunoconjugate, *Bioconjugate Chem.* **7**, No. 2, 165 (1996).
4. Jurisson, S., Berning, D., Jia, W., Ma, D.: Coordination Chemistry in Nuclear Medicine. *Chem. Rev.* **93**, 1137–1156 (1993).
5. Jia, W.: M. S. Thesis, University of Missouri-Columbia, 1991.
6. Shigeta, N., Matsuoka, Osa, A., *et al.*: Production Method of No-Carrier-Added ^{186}Re , International Conference on Isotopes, Beijing, China 1995.
7. Szilard, L., Chalmers, T. A.: *Nature* **134**, 462 (1934).
8. Jia, W., Ehrhardt, G. J.: Progress Toward Enhanced Specific Activity ^{186}Re Using Inorganic Szilard-Chalmers Methods, Technetium and Rhenium in Chemistry and Nuclear Medicine, 4, Bressabibe, Sgeditoriali Padova, 1995, p 379.
9. Cahn, R.: Ph. D. Thesis, Technical University of Munich, Munich, Germany 1995.

Effect of Stoichiometric and Preparation Parameters on W-188/Re-188 Gel Generator Performance*

By Q. Liang¹, G. J. Ehrhardt^{1,2,**}, A. R. Ketring^{1,2} and R. Miller²

¹ University of Missouri Chemistry Department, Columbia, MO 65211, USA

² University of Missouri Research Reactor, Research Park, Columbia, MO 65211, USA

(Received December 10, 1996; accepted in final form September 23, 1997)

*Rhenium-188 / Tungsten-188 / Generator /
Radiotherapy / Radioimmunotherapy / Radioisotopes*

Summary

Rhenium-188 is attractive for pre-targeted radioimmunotherapy because of its 17 hour half life, energetic beta emission, and availability from a generator. Gel-type W-188/Re-188 radioisotope generators utilize low specific activity W-188 (half-life 69.4 d) to produce compact isotope sources with conventional characteristics, thus expanding the number of reactors able to supply W-188 for radiotherapy. A simple "one pot" peroxide process has been described previously for this system [1]. Now the effects of gel stoichiometry, boiling rate, and gel digestion on generator parameters of yield, breakthrough, and elution rate have been determined. Optimum conditions give Re-188 yields of 60–80% and W-188 breakthrough values of $\sim 1 \times 10^{-4}\%$ /ml after the generator has been eluted 5–10 times. This Re-188 yield is comparable to that of Tc-99m from a Mo-99/Tc-99m generator made by this process. The most important factor for minimizing breakthrough is gel stoichiometry, which is easily controlled in the peroxide process, while boiling rate mainly affects yields and ease of column elution.

Introduction

In the last decade there has been a renewal of interest in therapeutic nuclear medicine, i.e., radiotherapy with internal, unsealed sources for malignancies, rheumatoid arthritis, and certain other human maladies [2–3]. Successful therapy depends upon matching the radionuclide with the chemistry and biological kinetics of a carrier molecule, and a variety of radionuclides have shown promise in clinical trials. One particularly attractive radionuclide is Re-188, which exhibits a 17 hour half life, chemical similarity to Tc-99m, 2.12 MeV beta emission, and low abundance, imageable gamma ray (155 keV, 15%).

Furthermore, Re-188 is available in no-carrier-added form from a W-188/Re-188 generator. Unfortunately, however, W-188 is produced by double neutron capture from W-186, and thus is only available in low specific activity. A great deal of work has been done to use W-188 from the highest flux reactor in the U.S., the High Flux Isotope Reactor (HFIR) at Oak Ridge National Laboratory, in adsorption-type alumina col-

umns, with some success [4]. The problem with this approach has been that even with W-188 from HFIR, relatively large volume columns are needed, and the eluate must then be concentrated for use.

An alternative approach has been taken at the University of Missouri Research Reactor (MURR) to produce W-188/Re-188 generators using a column packing of zirconium tungstate gel made from the target tungsten itself, from which Re-188 freely diffuses out in saline eluate as perrhenate [5]. This permits gram quantities of tungsten to be securely loaded onto columns with a volume of only a few milliliters, thus giving 60–70% yields of Re-188 in only 1–3 ml of eluate and removing the need to concentrate the product. This process has been refined into a "one-pot" peroxide method that is simple, reproducible, and convenient [1]. This work reports a study of the effect of various preparation parameters on the performance of the resulting generators.

Materials and methods

Samples of 99.7% isotopically enriched, W-186 tungsten metal, sodium tungstate, or tungsten trioxide were dried and encapsulated in quartz vials for irradiation in the MURR flux trap for 1–4 months at a thermal flux of 3×10^{14} neutrons/cm²/sec. Samples were processed in a glove box as previously described [1] using reagent grade chemicals. The finished gels were loaded into columns supplied by Mallinckrodt Medical, Inc., of the type used in the Ultratechnekow Tc-99m generator and eluted with normal saline, except as noted. Elution yield of Re-188 was assayed using an Atomlab 100 medical isotope dose calibrator, while column activity was assayed by comparison of the Re-188 yield to the change in activity of the 931 keV peak of Re-188 on the column, which was counted from within shielding before and after elution using a germanium detector and MCA. Tungsten-188 breakthrough in the eluate was measured after a two week decay, also using a germanium detector system. Elution profiles were obtained by milking the columns in 1 ml increments using tuberculin syringes. Parameters included the use of different heating block temperatures to vary the peroxide solution boiling rate, variation of the Zr:W molar ratio, and use of different eluting solutions.

* Presented at the Symposium on Radiochemistry and Radioimmunotherapy, Orlando, Florida, USA, August 1996.

** Author for correspondence.

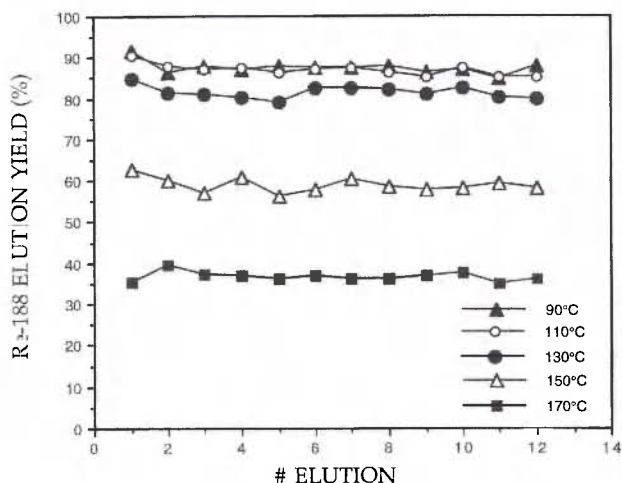

Fig. 1. Effect of various heating mantle temperatures on Re-188 elution yield vs. elution number.

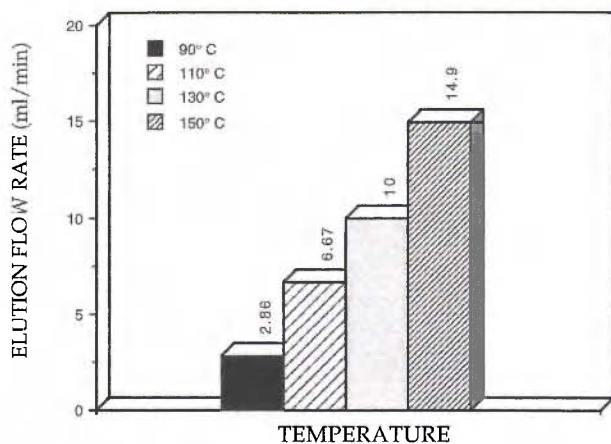

Fig. 2. Effect of heating mantle temperature on elution rate of Re-188.

Activity of W-188 used for generators ranged from 10 μ Ci (0.37 MBq) to 20 mCi (0.74 GBq), the lower levels for tests of different eluting solutions, counterions used to form the gel, and temperatures, while the larger activities were used for ascertaining W-188 breakthrough and studying optimized generators.

Results and discussion

Fig. 1 shows the dependence of Re-188 elution yield on heating mantle temperature. As it was not convenient to measure the temperature of the W-188 solution itself, a metal-stem thermometer placed in a hole drilled in the aluminum shield/heating block beneath the flask was used to monitor the approximate temperature of the solution. Thus, the exact solution temperature of the W-188 was not known, but trends were apparent as the temperature was increased. In particular, it was assumed higher temperatures led to more rapid rates of H_2O_2 decomposition and gel formation.

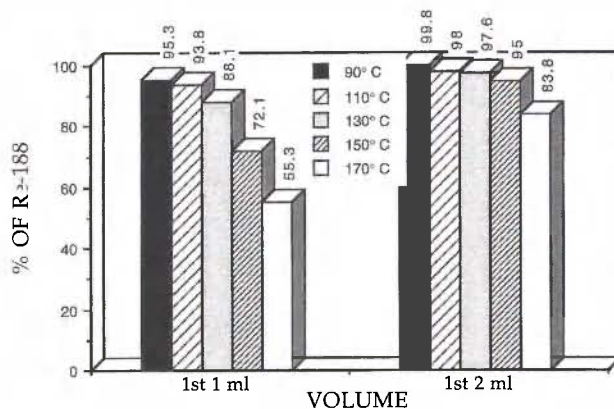

Fig. 3. Percentage of Re-188 in first 1 and 2 ml eluates at different heating mantle temperatures.

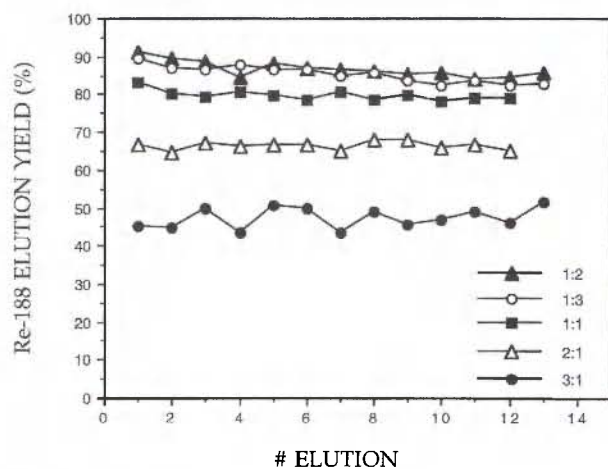

Fig. 4. Effect of various molar ratios of zirconium to tungsten on Re-188 elution yield vs. elution number.

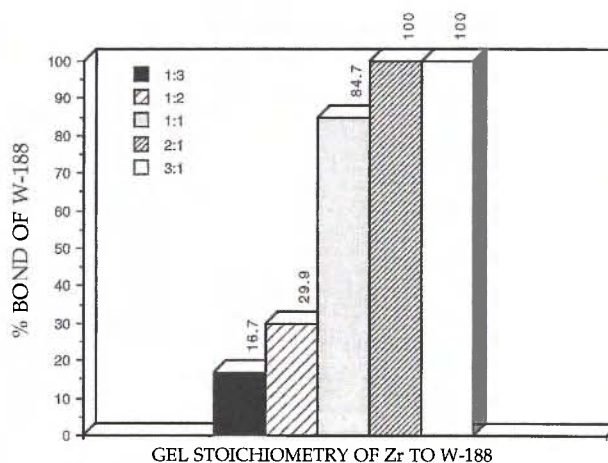

Fig. 5. Percentage of incorporated W-188 into insoluble zirconium tungstate gel at various gel stoichiometries.

As the peroxide decomposes and the zirconium tungstate gel forms, gaseous oxygen is released and results in a porous precipitate. The degree of porosity seen by SEM depends on factors such as the rate of decomposition (boiling) and the peroxide concentration. It is

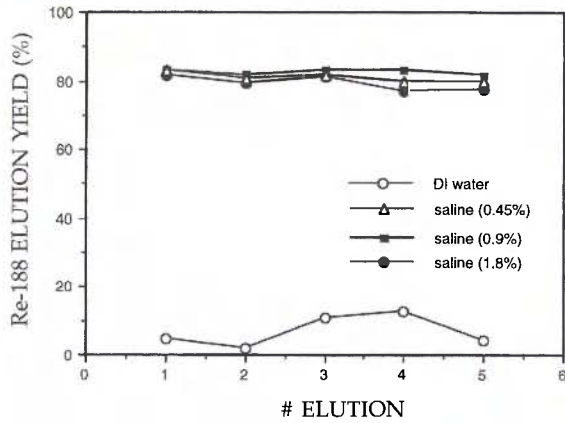

Fig. 6. Effect of various concentrations of saline on Re-188 elution yield.

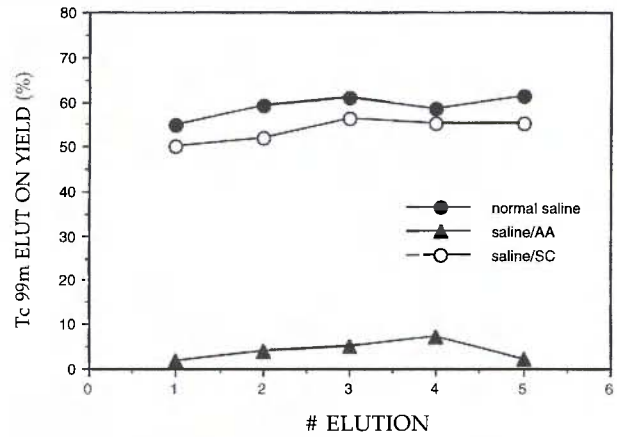

Fig. 8. Effect of the addition of ascorbic acid (AA) and sodium citrate (SC) in normal saline as eluants on Tc-99m elution yield.

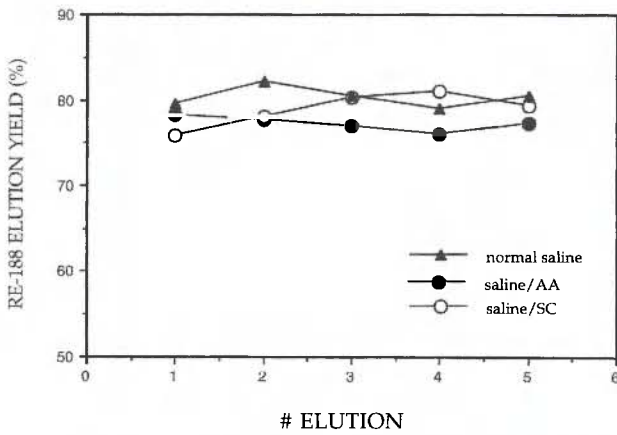

Fig. 7. Effect of the addition of ascorbic acid (AA) and sodium citrate (SC) in normal saline as eluants on Re-188 elution yield.

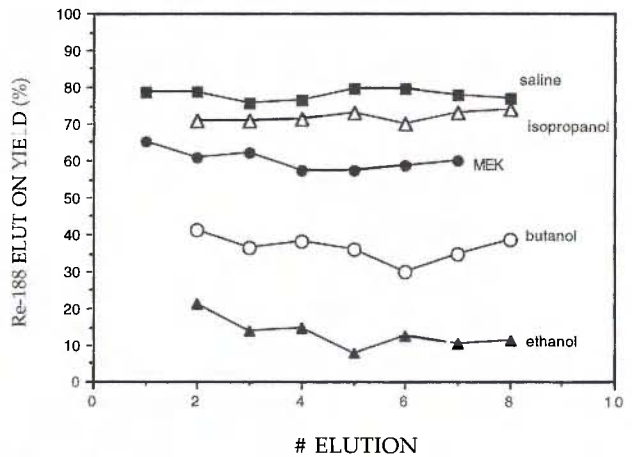

Fig. 9. Effect of different organic solvents as eluants on Re-188 elution yields.

evident from Fig. 1 that the yields are consistent with time, but decrease for higher heating temperatures. However, at the lower temperatures, there are considerable fines in the gel that lower the elution rate and can clog the column (Fig. 2). As demonstrated in Fig. 3, the elution profile is superior at lower temperatures. Thus, the optimum heating block temperature in our current system is about 130°C, a compromise between the best elution yield and profile, and reasonable flow rates.

A similar situation arises with respect to stoichiometry. Fig. 4 describes the elution yield decreases with increasing ratio of Zr:W. However, as shown in Fig. 5, complete incorporation of tungsten into the gel requires an excess of zirconium, so that once again a compromise must be reached. A Zr:W molar ratio of 1.5 to 2 is now used in our generator preparation for this reason.

Fig. 6 demonstrates that various concentrations of saline eluate give basically the same yield, while deionized water gives very little recovery of Re-188. Elution with saline/ascorbic acid and saline sodium citrate was not significantly different from saline alone

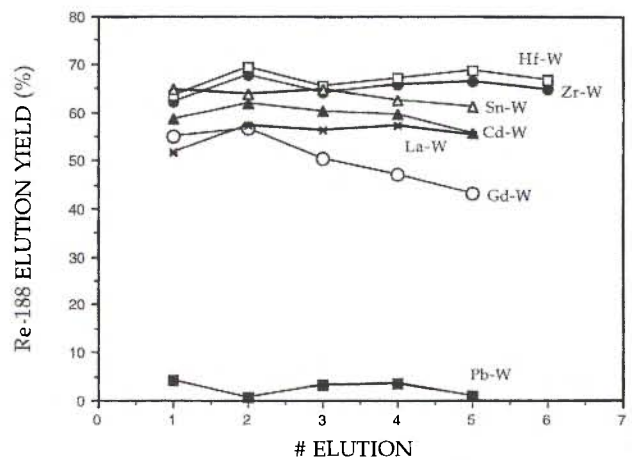

Fig. 10. Effect of various counterions on Re-188 elution yield of W-188/Re-188 generators.

(Fig. 7). Elution with saline/ascorbic acid (Fig. 8) markedly reduced the yield of Tc-99m. This discrepancy is likely the result of reduction of Tc-99m by

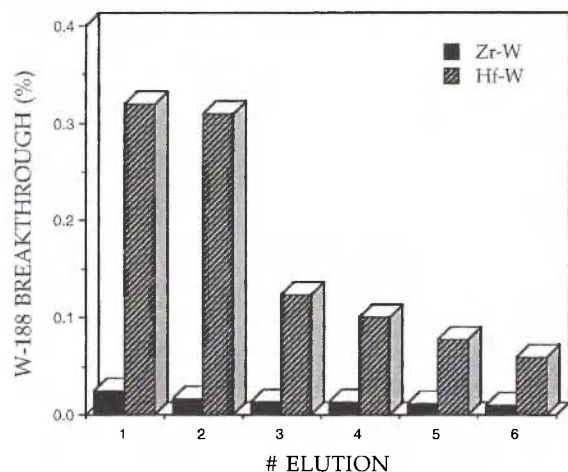

Fig. 11. W-188 breakthrough (%) from a Zr-W and a Hf-W generator vs. elution number.

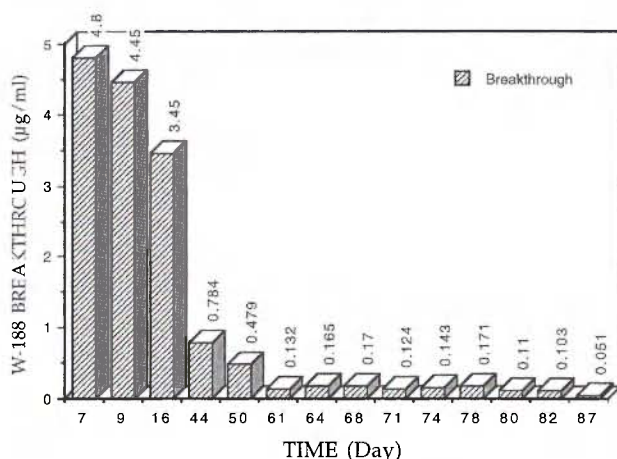

Fig. 12. W-188 breakthrough vs. time (days) from an improved gel W-188/Re-188 generator (14 mCi).

ascorbate to an insoluble, reduced hydrolyzed form such as TcO_2 ; perrhenate, being harder to reduce, does not exhibit this behavior. Fig. 9 shows the result of elution of identical gels with various organic eluants, suggesting again that saline is the optimal eluate of those tested.

A variety of counterions were used to evaluate alternatives to zirconium, with the dependence of elution yield versus cation shown in Fig. 10. It is readily evident that Hf provides similar elution yields to Zr. However, W-188 breakthrough from a hafnium tungstate gel is considerably greater than that from a zirconium tungstate gel (Fig. 11). Fig. 12 shows the time dependence of W-188 breakthrough from a zirconium tungstate gel. In Fig. 12, the amount of tungsten on the column was about 1 gram, so that breakthrough rapidly decreases to less than $10^{-4}\%$ of the column

tungsten activity. Breakthrough values of about 1 ppm/ml eluate, decreasing consistently over time, are characteristic of these gel generators.

Conclusions

In regular production, parameters such as heating rate and stoichiometry can be fine-tuned to yield optimal generators. The preparation conditions will of necessity be compromises between conflicting requirements of generator performance, e.g., high Re-188 yield and good elution rate. The striking dependence of generator performance on gel stoichiometry favors the consistency of the peroxide process, in that the gel components are mixed into a homogeneous, clear solution, and only precipitate to form the gel upon heating.

Homogeneous gel generators permit gram loadings of tungsten onto small columns, thus giving very compact elution profiles with no need to concentrate the product and with inherent protection against catastrophic W-188 breakthrough. Furthermore, this generator design permits useful W-188 to be produced in numerous intermediate flux reactors, and thus reduces dependence on the handful of extremely high flux reactors that operate in the world. This consideration in particular is a vital one for any industrial interest in producing W-188/Re-188 generators.

Acknowledgment

The authors would like to express their gratitude to Mallinckrodt Medical, Inc., for their generous support of this work.

References

1. Volkert, W. A., Goeckeler, W. F., Ehrhardt, G. J., Ketring, A. R.: Therapeutic Radionuclides: Production and Decay Property Considerations. *J. Nucl. Med.* **32**, 174–185 (1991).
2. Vanderheyden, J.-L., Fritzberg, A. R., Rao, T. N. *et al.*: Rhenium Labeling of Antibodies for Radioimmunotherapy. *J. Nucl. Med.* **28**, 656 (ab) (1987).
3. Griffiths, G. L., Goldenberg, D. M., Sharkey, R. M., *et al.*: Evaluation of a W-188/Re-188 Generator System as a Ready Source of Re-188 for Use in Radioimmunotherapy (RAIT). *Radioact. Radiochem.* **3**(4), 33–37 (1992).
4. Ehrhardt, G. J., Ketring, A. R., Turpin, T. A., *et al.*: A Convenient W-188/Re-188 Generator for Radiotherapeutic Applications Using Low Specific Activity W-188. In: *Technetium in Chemistry and Nuclear Medicine 3*, Cortina Intl., Verona, Italy (Raven Press, New York, April 1990), p. 631.
5. Ehrhardt, G. J., Ketring, A. R., Liang, Q., *et al.*: Refinement of the Peroxide Process for Making W-188/Re-188 and Mo-99/Tc-99m Gel Radioisotope Generators for Nuclear Medicine. In: *Technetium and Rhenium in Chemistry and Nuclear Medicine 4*, eds. M. Nicolini, G. Bandoli, and U. Mazzi, (SGEditoriali, Padova, Italy 1995).

An Improved Generator for the Production of ^{213}Bi from $^{225}\text{Ac}^*$

By Chuanchu Wu**, Martin W. Brechbiel and Otto A. Gansow

Inorganic and Radioimmune Chemistry Section, Radiation Oncology Branch, NCI, NIH, Bethesda, MD 20892-1002, USA

(Received December 10, 1996; accepted in revised form May 21, 1997)

$^{225}\text{Ac} / ^{213}\text{Bi} / \text{Generator} / \text{Radioimmunotherapy} / \text{Actinide}$

Summary

An improved generator was developed using a silica-based extraction chromatographic resin, Eichrom Silica Actinide Resin (Eichrom, Darien, IL), for the production of the α -emitting radionuclide ^{213}Bi and to minimize radiolysis of the $^{225}\text{Ac}/^{213}\text{Bi}$ generator. Ac-225 was adsorbed and evenly distributed on the top two-thirds of the generator resin. Bi-213 was eluted quantitatively with 1.0 M HCl. Simultaneous elution of the generator, subsequent dilution and re-adsorption of ^{213}Bi onto an MP-50 column to concentrate the activity was performed by assembling the columns in series. Breakthrough of ^{225}Ac from the generator was <0.05%, and no ^{225}Ac was found when ^{213}Bi was eluted from the second column. Bi-213 obtained can be easily used to radiolabel appropriate protein chelating agent conjugates. Hypothetically, resin damage by α -radiolysis should be obviated by employing such a silica-based resin and by broad distribution of the ^{225}Ac on the column.

Introduction

The α -emitting radionuclides chelated to tumor-specific monoclonal antibodies can yield a high degree of tumoricidal activity yet spare the surrounding normal tissue [1, 2], due to their short penetration range (40–100 μm) and high linear energy transfer (LET) in tissue. The use of α -emitters in systemic radioimmunotherapy has been postulated as the treatment of choice for leukemia and highly vascularized tumors [3], and when administered intra-abdominally, as a potential useful tool for treatment of intraperitoneal malignancies and micro-metastases [2].

In recent years, ^{212}Bi ($T_{1/2} = 60.6$ min) has been considered to be the α -emitter of choice [3]. This isotope can be routinely obtained from a $^{224}\text{Ra}/^{212}\text{Bi}$ generator [4, 5]. When linked to a tumor specific monoclonal antibody through the bifunctional chelating agent *p*-SCN-Bz-CHX-DTPA developed in this laboratory, ^{212}Bi has been successfully used for radioimmunotherapy studies of leukemic mice [6]. Efforts are currently underway to transfer this system to human clinical trials. One disadvantage, however, of ^{212}Bi is the shielding requirements that arise from the 2.26 MeV γ -ray of the ^{212}Bi daughter, ^{208}Tl . For this reason, a hot cell of substantial dimensions is needed

for the safe preparation of radioimmunoconjugate patient doses.

Another α -emitting bismuth isotope, ^{213}Bi ($T_{1/2} = 45.6$ min) has recently been promoted as an alternative to ^{212}Bi [7–10]. Bi-213 has far fewer intense γ -ray emissions than does ^{212}Bi . Additionally, ^{213}Bi emits a 440 keV γ -ray which may generate images comparable to that of ^{131}I , potentially providing simultaneously therapy and imaging. The advantage gained due to simpler shielding requirements, however, is somewhat compromised by the yet shorter half-life.

Bi-213 is available through an $^{225}\text{Ac}/^{213}\text{Bi}$ generator [7–9]. We had prepared this generator initially employing cation-exchange resin MP-50 previously used for the $^{224}\text{Ra}/^{212}\text{Bi}$ generator [10]. However, this generator failed to function after a few days when larger amounts of ^{225}Ac were loaded onto the generator, such as 74 MBq (20 mCi), due to visible radiolysis of the resin.

In order to minimize radiation damage to the support, we investigated the use of a silica-based extraction chromatographic resin, developed for use with actinides, for the development of $^{225}\text{Ac}/^{213}\text{Bi}$ generator in the current studies.

Experimental

Materials

Ultrapure hydrochloric and nitric acids were obtained from J. T. Baker. MP-50 cation-exchange resin (100–200 mesh, H^+ form) was purchased from BioRad. Eichrom Silica Actinide Resin (Ac-Resin) and Ln-spec resin were obtained from Eichrom Industries, Inc. Darien, IL. The bifunctional chelating agent *p*-SCN-Bz-CHX-A-DTPA was synthesized, and conjugated to anti-Tac monoclonal antibody (Chelator:Protein = 1.2) as previously described [11, 12].

Measurement of the radioactivities

A 8192 channel multi-channel analyzer (Canberra, Meriden, CT) equipped with two high purity Ge detectors, model GLP-16195/10 for low-energy γ -ray and model GEM-10185 for higher-energy γ -ray (EG and G Ortec, Oak Ridge, TN), was used for high resolution γ -ray spectroscopy. The ^{225}Ra and ^{213}Bi activities were determined by measurement of their 40 keV X-ray and 440.4 keV γ -ray, respectively. To quantify the

* Presented at the Symposium on Radiochemistry and Radioimmunotherapy, Orlando, Florida, USA, August 1996.

** Corresponding author.

^{225}Ac activity, the intensity of the 218 keV γ -ray of its ^{221}Fr daughter nuclide ($T_{1/2} = 4.8$ min) was measured at secular equilibrium with the parent.

Separation of ^{225}Ac from ^{225}Ra

Ac-225 was supplied by Pacific Northwest National Laboratory, Richland, WA, as the mixture with ^{225}Ra . The ^{225}Ra was removed by column extraction chromatography with Ln-Spec resin. Briefly, the mixture of ^{225}Ra and ^{225}Ac in 0.1 M HNO_3 was loaded onto a column of Ln-Spec resin (4×20 mm). After ^{225}Ra was eluted from the resin with 0.1 M HNO_3 , the ^{225}Ac was eluted with 0.5 M HNO_3 .

Determination of weight distribution coefficient of Ac-Resin

The sorption of $^{225}\text{Ac(III)}$ and $^{213}\text{Bi(III)}$ from HCl solution by the Ac-Resin was measured by contacting 2.0 ml of a spiked acid solution of appropriate concentration with a known weight of the resin (50–100 mg). The mixing of the solid and liquid phases was performed by gently shaking for 30 min at 25°C. After equilibrium, the resin was removed by filtration through Whatman #1 paper.

Weight distribution coefficients were calculated from the following equation:

$$D_w = \frac{(A_0 - A_s)/W}{A_s/V}$$

where A_0 and A_s are the aqueous phase activities before and after equilibration, respectively, and W is the weight of resin (g) and V is the aqueous phase volume (ml).

Preparation of the $^{225}\text{Ac}/^{213}\text{Bi}$ generator

A column (8×2 mm) was packed with Ac-Resin (1 ml) and the resin equilibrated with 0.5 M HNO_3 . About two-thirds of the resin was removed from the column, and added to a test-tube containing 2.96 MBq (0.8 mCi) ^{225}Ac in 0.5 M HNO_3 (2 ml). The mixture was incubated at room temperature for 30 min with occasional shaking. The resin was then returned to the column, and equilibrated with 1.0 M HCl. All of the solutions were collected, and assayed for ^{225}Ac activity.

Elution of the $^{225}\text{Ac}/^{213}\text{Bi}$ generator

Bi-213 was eluted from the $^{225}\text{Ac}/^{213}\text{Bi}$ generator with 1.0 M HCl, and then concentrated with a second column of MP-50 resin. A specially designed system (Fig. 1) was used to perform the operation.

The system contains two peristaltic pumps (Pharmacia, Sweden). From the first pump, 1.0 M HCl was

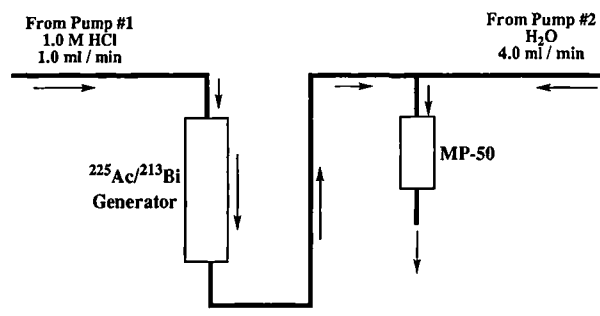

Fig. 1. The $^{225}\text{Ac}/^{213}\text{Bi}$ generator elution system.

delivered at 1.0 ml/min to the $^{225}\text{Ac}/^{213}\text{Bi}$ generator to elute the ^{213}Bi . The HCl solution was then mixed with H_2O delivered by the second pump at 4.0 ml/min. The resulting diluted eluate ($[\text{HCl}] = 0.2$ M) was then passed through the column of MP-50 resin (5×1.5 mm). After 6 min, the MP-50 column was disconnected from the system, and ^{213}Bi was eluted from this column with 0.5 ml of 0.1 M HI delivered via syringe.

The generator was eluted twice a day (3–5 hours apart) on weekdays for two weeks. The yield of ^{213}Bi and the ^{225}Ac breakthrough after the generator and the MP-50 column were determined.

Radiolabeling of mAb conjugates

Radiolabeling was performed by adjusting the pH of ^{213}Bi in 0.1 M HI with 3.0 M NH_4OAc to 5.0–5.5. The anti-Tac-CHX-A-DTPA was added to the solution, and after 6 min incubation at room temperature, 5 μl of 0.1 M EDTA were added. The radiolabeled antibody was purified with a size-exclusion HPLC column TSK 3000SW (TosoHaas, Japan, elute with PBS at 1.0 ml/min).

Results and discussion

The ^{225}Ac can be separated from ^{225}Ra with Dowex 50W-X8 cation exchange resin [13, 14], however, this chromatography is inconveniently performed at 60°C or 80°C. Also, we found the yield of ^{225}Ac by this method to be relatively poor. In this study we explored the potential for use of the extraction chromatographic resin, Ln-spec, to separate these two isotopes. The Ln-spec resin uses a polymeric support, Amberlite XAD-7 beads, impregnated with extractant bis(2-ethylhexyl)phosphoric acid (HDEHP). The Ac-Resin employs silica beads impregnated with the extractant di-2-ethylhexyl-methylene-bis-phosphonic acid. This separation of the isotopes was performed at room temperature, and yielded quantitative recovery for ^{225}Ac .

The acid dependency of weight distribution coefficient D_w of the Ac-Resin for trace amounts of Ac(III) and Bi(III) is shown in Fig. 2. Ac(III) was retained very strongly by the resin over a wide range of

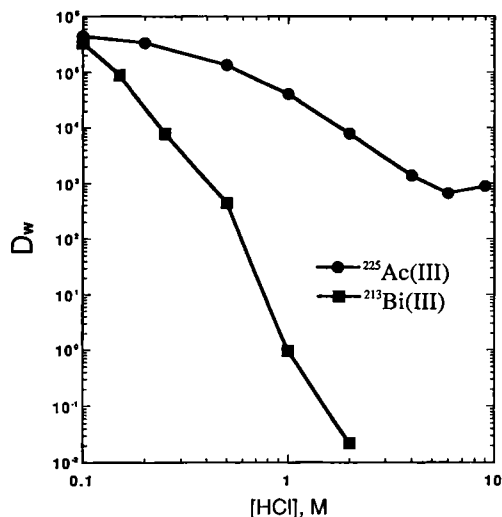

Fig. 2. Acid dependency of weight distribution coefficient of silica Ac-Resin for $^{225}\text{Ac(III)}$ and $^{213}\text{Bi(III)}$ at 25°C.

HCl concentration. The resin also showed high affinity for Bi(III) at low acid concentration, but the distribution coefficient sharply decreased with increasing HCl concentration. We chose 1.0 M HCl as the generator eluent, wherein the weight distribution coefficient of the Ac-Resin for Ac(III) is greater than 10^5 , while approximately unity for Bi(III).

If ^{225}Ac was loaded onto the column by simply passing the solution through the column ^{225}Ac was adsorbed on a very thin layer of resin at the top of the generator due to the extremely strong affinity of the Ac-Resin for Ac(III). The radioactivity density then would be great regardless of column size, and consequently, this portion of the resin bed suffers radiolysis damage. Our technique of packing the column described herein obviates this deleterious effect by evenly distributing the ^{225}Ac over the upper two-thirds of the column. Before re-packed to the column, the Ac-Resin retained >99% of ^{225}Ac , confirmed by counting

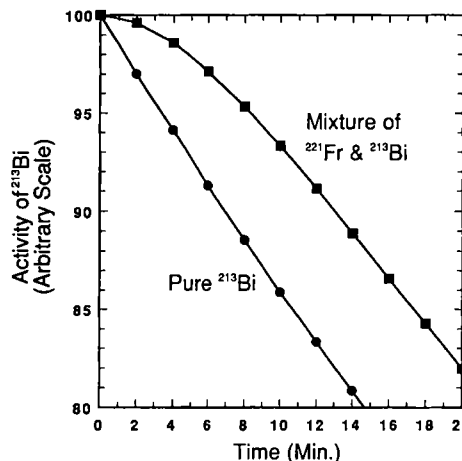

Fig. 4. The decay curves of ^{213}Bi and a mixture of $^{221}\text{Fr}/^{213}\text{Bi}$ with equal amount at $t=0$.

the aqueous aliquot. The remaining resin then is in place to eliminate ^{225}Ac breakthrough during the preparation and the elution of the generator. Less than 0.5% of the total ^{225}Ac was found in the solution collected during the preparation of the generator.

Five column volumes were required to completely (>96%) elute ^{213}Bi from the generator (Fig. 3). To insure maximum yield of ^{213}Bi , six column volumes of 1.0 M HCl were used to elute the generator. However, this leaves the activity in 6 ml (for a 1 ml generator), too large a volume for practical radiolabeling of antibody conjugates. Additionally, we have proposed to employ even larger generators with clinically useful amounts of ^{225}Ac , to decrease the resin radiation density to minimize radiolysis. Therefore, the ^{213}Bi solution must be concentrated for further use and for radiolabeling protein conjugates. This was easily done by directly loading the dilute ^{213}Bi solution onto a MP-50 cation exchange column.

The optimal acid concentration to retain the ^{213}Bi on MP-50 resin was found to be 0.2 M HCl, thus, a

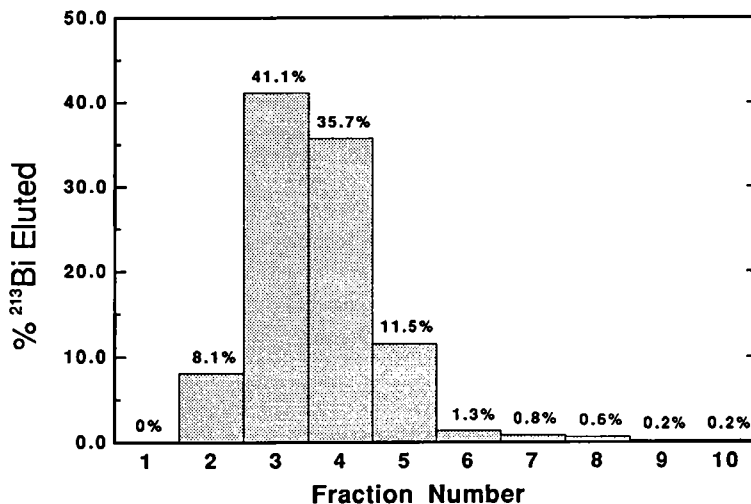

Fig. 3. Elution profile of ^{213}Bi from the $^{225}\text{Ac}/^{213}\text{Bi}$ generator with 1.0 M HCl. Each fraction contains 1.0 ml eluent. Column size: 8×20 mm, 1 ml).

5-fold dilution was required. Under these conditions, greater than 95% of the ^{213}Bi activity from the generator was retained by the MP-50 column when the solution was passed through the MP-50 column at 5 ml/min. If the eluate from the generator was diluted to 0.1 M or 0.3 M HCl, 8% and 11% of the ^{213}Bi was not retained on the MP50 column, respectively.

The decay loss of ^{213}Bi during the elution is minimal for two reasons. First, elution of the generator and the subsequent concentration were performed as a continuous flow process and the loss of ^{213}Bi by decay during this process would be replaced in part by the growth of ^{213}Bi in the generator. Secondly, the decay of the short-lived parent, ^{221}Fr ($T_{1/2} = 4.8$ min), that was also eluted from the generator and then also retained by the MP-50 resin, produces ^{213}Bi by decay. As seen in Fig. 4, almost 10% of ^{213}Bi will be decayed after 6 min from a pure ^{213}Bi source and only 3% is effectively decayed for a mixture of equal amounts of ^{221}Fr and ^{213}Bi .

The overall yield of ^{213}Bi from our generator system is greater than 85% without decay correction. Breakthrough of ^{225}Ac from the column of the generator is $<0.05\%$ after greater than 20 elutions and no ^{225}Ac was observed after ^{213}Bi was concentrated through the MP-50 column.

The chemical purity of the ^{213}Bi final product was high, confirmed by its easy labeling of anti-Tac conjugated with CHX-A-DTPA. Typical radiolabeled protein product specific activities ranged from 37–74 MBq/mg (10–20 mCi/mg) as calculated after purification.

Although the packing technique described herein could be applied to MP-50 resin employed for the $^{224}\text{Ra}/^{212}\text{Bi}$ generator, we were unable to develop an efficient method to concentrate ^{213}Bi in an HI solution within acceptable time limits. If HCl (0.5 M minimum for elution of Bi from MP50) was used, measurable ^{225}Ac breakthrough began after ~ 10 column volume elutions.

In conclusion, the new generator employed a silica-based extraction chromatographic resin, Ac-Resin, retained ^{225}Ac very tightly, while ^{213}Bi could be readily eluted with 1.0 M HCl. The ^{225}Ac was evenly distributed in the upper two-thirds of the generator column, which was expected to distribute and decrease the radiation density. Addition of a concentration step after generator elution not only eliminated possible ^{225}Ac breakthrough, but also potentially allowed increase the generator column size to further decrease radiation density. The new generator design for elimi-

nating radiolysis damage continues to be investigated pending availability of ^{225}Ac (>74 MBq).

Acknowledgments

Thanks are due to Dr. Robert Shenter and Dr. Lane Bray (Pacific Northwest National Laboratory) who supplied the ^{225}Ac activity.

References

- Humm, J. L., Chin, L. M.: A Model of Cell Inactivation by Alpha-Particle Internal Emitters. *Radiat. Res.* **134**, 143 (1993).
- Macklis, R. M., Kinsey, B. M., Kassis, A. I., Ferrara, J. L. M., Atcher, R. W., Hines, J. J., Coleman, C. N., Adelstein, S. J., Burakoff, S. J.: Radioimmunotherapy with Alpha-Particle-Emitting Immunoconjugates. *Science* **240**, 1024 (1988).
- Wilbur, S.: Potential use of α -emitting Radionuclides in the Treatment of Cancer. *Antibody, Immunoconj. Radiopharm.* **4**, 85 (1991).
- Atcher, R. W., Hines, J. J., Friedman, A. M.: A Remote System for the Separation of ^{228}Th and ^{224}Ra . *J. Radioanal. Nucl. Chem. Lett.* **117**, 155 (1987).
- Atcher, R. W., Friedman, A. M., Hines, J. J.: An Improved Generator for the Production of ^{212}Pb and ^{212}Bi from ^{224}Ra . *Appl. Radiat. Isot.* **39**, 283 (1988).
- Huneke, R. B., Pippin, C. G., Squire, R. A., Brechbiel, M. W., Gansow, O. A., Strand, M.: Effective α -Particle-mediated Radioimmunotherapy of Murine Leukemia. *Cancer Res.* **52**, 5818 (1992).
- Geerlings, M. W.: Radionuclides for Radioimmunotherapy: Criteria for Selection. *Intl. J. Biol. Markers* **8**, 180 (1993).
- Geerlings, M. W., Kaspersen, F. M., Apostolidis, C., Van Der Hout, R.: The Feasibility of Ac-225 as a Source of α -Particles in Radioimmunotherapy. *Nucl. Med. Commun.* **14**, 121 (1993).
- Geerlings, M. W.: Radioimmunotherapy Using α -Particles Emission. *Int. Patent* WO 90/15625 (1990).
- Pippin, C. G., Gansow, O. A., Brechbiel, M. W., Koch, L., Molinet, R., Van Geel, J., Apostolidis, C., Geerlings, M. W., Scheinberg, D. A.: Recovery of Bi-213 from an Ac-225 Cow: Application to the Radiolabeling of Antibodies with Bi-213. In: *Chemists' Views of Imaging Centers* (A. M. Emran, ed.) Plenum Press, New York 1995.
- Brechbiel, M. W., Gansow, O. A.: Synthesis of C-Functionalized Derivatives of trans-Cyclohexyldiethylenetriaminepentaacetic Acid for Labeling of Monoclonal Antibodies with the ^{212}Bi Alpha-particle Emitter. *J. Chem. Soc., Perkin Trans. 1*, 1173 (1992).
- Mirzadeh, S., Brechbiel, M. W., Atcher, R. W., Gansow, O. A.: Radiolabeling of Immunoproteins: Covalent Linkage of 2-(4-Isothiocyanatobenzyl)diethylenetriamine-pentaacetic Acid Ligands to Immunoglobulin. *Bioconjugate Chem.* **1**, 59 (1990).
- El Samad, O., Dalmaso, J., Barcl-Funel, G., Ardisson, G.: Fast radiochemical Separation and γ Spectroscopy of Short-lived Thallium Isotopes. *Radiochim. Acta* **62**, 65 (1993).
- Kouassi, M. C., Dalmaso, J., Maria, H., Ardisson, G., Hussonnois, M.: On the γ -Spectrum Following ^{225}Ac α -Decay. *J. Radioanal. Nucl. Chem. Lett.* **144**, 387 (1990).

Optimizations of Radiolabeling of Immunoproteins with ^{213}Bi *

By Rose A. Boll, Saed Mirzadeh** and Stephen J. Kennel

Divisions of Health Sciences Research and Biology, Oak Ridge National Laboratory, Oak Ridge, TN 37831-6226, USA

(Received January 10, 1997; accepted in revised form May 23, 1997)

$^{225}\text{Ra} - ^{225}\text{Ac} - ^{213}\text{Bi}$ / Multidentate ligands / CHX-b-DTPA / Alpha-particle mediated radio-immunotherapy / Radiochemistry

Summary

Carrier-free ^{213}Bi ($t_{1/2} = 45.6$ m, an α -emitter) is available from the $^{225}\text{Ra}/^{225}\text{Ac}/^{213}\text{Bi}$ generator system with ^{225}Ra ($t_{1/2} = 14$ d) and ^{225}Ac ($t_{1/2} = 10$ d) being the daughters of 7340-y ^{229}Th which, in turn, is the decay daughter of long-lived ^{233}U . In the current generator system, $^{225}\text{Ra}/^{225}\text{Ac}$ is adsorbed on an organic cation exchange resin (AG 50X4, X8 or highly cross-linked AG MP-50) and ^{213}Bi is eluted with 0.1 M HI. We have found the lower cross-linked resin to be more suitable for rapid elution of ^{213}Bi from the generator with ^{225}Ac breakthrough of $<1\%$. Generators were typically made from Ac separated from Ra as the breakthrough of Ra is significantly higher than that of Ac. Generator elution of ^{213}Bi , labeling of MAbs and HPLC purification were accomplished within 35–40 min. Radiolabeling yields of CHX-b-DTPA-conjugated MAbs (34A and 14) were $>50\%$ with specific activity of ~ 200 μCi of ^{213}Bi per 150 μg of conjugated protein.

Introduction

Due to their short range in tissue (a few cell diameters), and high linear-energy-transfer (LET), alpha particles are of considerable interest for therapeutic applications, especially for treatment of leukemia and other blood borne disease [1–5]. Most recently, their applications with vascular targeting antibodies for treatment of lung cancer have been under evaluation [6]. The list of potential radionuclides for alpha-particle mediated radioimmunotherapy includes only four α -emitting radioisotopes, namely ^{211}At ($t_{1/2} = 7.2$ h) [7], ^{212}Bi ($t_{1/2} = 60.6$ m) [8, 9], ^{213}Bi ($t_{1/2} = 45.6$ m) and ^{255}Fm ($t_{1/2} = 20$ h) [10]. Among these possible candidates, ^{255}Fm (the daughter of 40-d ^{255}Es , a transuranium radioisotope) has the most convenient half-life, but it is doubtful that useful quantities of this radioisotope will be made available within the foreseeable future. The availability of ^{211}At is also very limited because there are only a few cyclotrons in the U.S. capable of accelerating α -particles to ~ 28 MeV, which is the required energy for production of ^{211}At via the ^{209}Bi [$\alpha, 2n$] reaction (the predominant production route). Bismuth-212 is available from the $^{224}\text{Ra}/^{212}\text{Bi}$ generator system, where ^{224}Ra is the daughter of

1.9-y ^{228}Th [8]. The major drawback for the use of ^{212}Bi is emission of a relatively intense and very high energy γ -rays (2.6 MeV, 38%). The presence of this high energy γ -ray is a debilitating risk to the patient, the patient's family members and the medical staff involved in the treatment. Bismuth-213, on the other hand, emits a 1.5 MeV γ -ray with a probability of only 2%. Similarly, carrier-free ^{213}Bi is available from the $^{225}\text{Ac}/^{213}\text{Bi}$ generator system with ^{225}Ac ($t_{1/2} = 10$ d) being the daughter of 7340-y ^{229}Th which, in turn, is the decay daughter of long-lived ^{233}U .

In this work, we evaluated a 2 mCi generator for ^{213}Bi yield and elution profile, and ^{225}Ra and ^{225}Ac breakthroughs. The generator was eluted 28 times during a 18-day period. Parallel with the evaluation of the generator, we studied the influence of various parameters on the ^{213}Bi labeling yields of three chelate-modified monoclonal antibodies. In addition, we examined the potential use of extraction column chromatography for separation of Ac from Ra.

Experimental

Materials, reagents and instrumentation

To reduce metal ion contamination, specifically the common metals [e.g. Fe(III), Zn(II), Cu(II)], plasticware (metal-free low protein binding polypropylene) was used in almost all protein work. Chelex-100 chelating ion exchange resin (Na^+ form, 100–200 mesh) and the AG 50WX4 cation resin (H^+ form, 200–400 mesh) were purchased from Bio-Rad Laboratories. The resins were washed with and stored under deionized H_2O . As needed, AG 50WX4 was converted to nitrate form by contacting resin with 8 M HNO_3 and rinsing with deionized H_2O . LN resin (HDEHP impregnated polymers, 100–150 μm) was obtained from EICrom Industries Inc. All other reagents used were of analytical grade or better. In general, all buffers were passed through a column of Chelex-100 resin (2.5×10 cm, pre-equilibrated with the same buffer) and finally, prior to storage at 4°C , they were filtered through a 0.22 micron sterile cellulose acetate membrane filtration unit (e.g. Corning 25942, Corning, NY). Ra/Ac-225 was from ORNL or was purchased from Pacific Northwest National Laboratory (PNNL). Monoclonal Antibodies 273-34A (34A), 411-201B (201B) and 135-14 (14) were prepared at ORNL [11]. Bifunctional chelating ligand Cyclohexyl-diethyl-

* Presented at the Symposium on Radiochemistry and Radioimmunotherapy, Orlando, Florida, USA, August 1996.

** Author for correspondence.

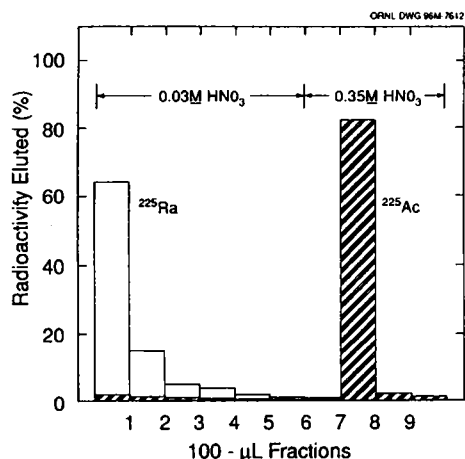

Fig. 1. Separation of ^{225}Ra and ^{225}Ac by column extraction. Column: $\sim 2 \times 20$ mm, ~ 250 μL of LN resin (HDEHP impregnated polymers), 100–150 μm (EiChrom Ind. Inc.); Load: 100 μCi of ^{225}Ac and ^{225}Ra in 100 μL of 0.03 M HNO_3 ; Flow rate: ~ 0.5 mL/min.

enetriaminepentaacetic Acid (CHX-DTPA, isomers a and b) was furnished by Dr. M. Brechbiel and late Dr. O. A. Gansow at the National Institutes of Health [12].

Separation of Ac from Ra and Preparation of $^{225}\text{Ac}/^{213}\text{Bi}$ generator

The generator was made from ^{225}Ac separated from Ra. Separation of Ac/Ra was achieved by extraction column chromatography using LN resin, where the Ra/ ^{225}Ac mixture (~ 200 μCi) in 0.01 M HNO_3 was loaded onto a 3×20 mm column containing ~ 250 μL of LN resin. The generator was then washed with 3 column volumes of 0.03 M HNO_3 to remove all Ra, and subsequently, Ac was eluted with 0.3 M HNO_3 . The ^{225}Ac solution was evaporated to dryness and residue redissolved in 3×200 μL of 1 M HNO_3 and loaded onto a new column (2×1.5 mm, AG 50WX4, 200–400 mesh in NO_3^- form, pre-equilibrated with 1 M HNO_3). The generator was then washed with 200 μL of H_2O and allowed to stand for at least 3 hours for ^{213}Bi activity to reach equilibrium ($\sim 90\%$). Carrier-free ^{213}Bi was selectively eluted from generator using 0.15 M HI, buffered to pH 3.8–4.5 with NaOAc for the subsequent radiolabeling procedure.

Preparation of ^{213}Bi -labeled antibody

CHX-DTPA conjugated antibody was prepared with the ligand-to-protein-molar ratio of 1-2 according to procedure of Mirzadeh *et al.* [13]. The unconjugated or free ligand was separated from protein by serial dialysis (2×500 mL of citrate buffer for 16 hours each and then against 500 mL of MES buffer for a few hours). The final ligand to protein molar ratio, $(\text{CL}/\text{P})_0$, of the conjugated antibody was then determined [14, 15]. The chelate conjugated antibody was labelled with ^{213}Bi as follows: buffered solution (pH 3.8–4.5) of $^{213}\text{BiI}_3$ containing ~ 500 μCi of ^{213}Bi was mixed

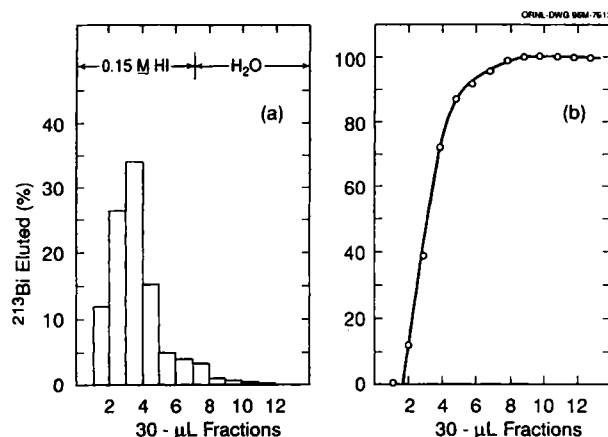

Fig. 2. Elution profile of the ^{213}Bi generator. Column: $\sim 2 \times 15$ mm, ~ 200 μL of AG50W-X4 resin, 200–400 mesh; Load: 30 μCi ^{225}Ac and 1.1 μCi ^{225}Ra in 100 μL of 1.0 M HNO_3 ; Flow rate: ~ 0.5 mL/min.

with ~ 10 μL of CHX-MAb (~ 10 mg/mL). The reaction pH was raised to 5.0–5.5 by addition of μL aliquots of 3 M NaOAc. The reaction mixture was placed in a constant temperature bath for the desired period of time, then the reaction was quenched by adding 2 μL 10 mM Na_2EDTA to scavenge any free ^{213}Bi . Subsequently, the radiolabeled antibody was purified from unreacted ^{213}Bi by HPLC employing a TSK-400 size exclusion column. The HPLC was operated isocratically at pH = 6.2 (MES buffer) with 1.0 ml/min flow rate, and was equipped with dual on-line UV- and radioactivity detectors. Radiolabeling yield was determined as the ratio of the radioactivity under protein peak to the total activity in all fractions.

Results and discussion

Results of separation of ^{225}Ra and ^{225}Ac by column extraction employing LN column are depicted in Fig. 1. As shown, complete separation of Ac from Ra can be achieved by loading the mixture on the LN column from 0.01 M HNO_3 followed by 3 column volumes of 0.03 M HNO_3 rinse. Elution of Ac from the LN column can be selectively achieved by use of 0.3 M HNO_3 . Sharper elution of Ac from the LN column can be accomplished with acid of higher concentration if there were no potential of contamination from Th. The elution profile of ^{213}Bi from the Ac/Bi generator is shown in Fig. 2. In this case the load solution consisted of 830 μCi ^{225}Ac and 1.1 μCi ^{225}Ra in 100 μL of 1.0 M HNO_3 . As shown, the first column volume (~ 200 μL) contains 95% of the ^{213}Bi , and quantitative elution can be achieved by washing column with additional 60 μL of H_2O . A summary of the ^{213}Bi yield and ^{225}Ac and ^{225}Ra breakthrough values are given in Table 1. As indicated in the last column, the breakthrough of Ra in AG 50WX4 resin was substantially higher than Ac breakthrough. Thus it follows that in order to reduce the potential contamination of

Table 1. ²²⁵Ac/²¹³Bi generator — ²¹³Bi yield, ²²⁵Ac and ²²⁵Ra breakthrough

Elution No.	Date (d)	²¹³ Bi yield (μCi)	Breakthrough				Ra/Ac
			²²⁵ Ac		²²⁵ Ra		
			(μCi)	(%)	(μCi)	(%)	
1	3	650	4.3 × 10 ⁻³	6.4 × 10 ⁻⁴	2.8 × 10 ⁻³	2.9 × 10 ⁻¹	453
6	4	615	6.7 × 10 ⁻³	1.1 × 10 ⁻³	1.2 × 10 ⁻³	1.3 × 10 ⁻¹	118
15	11	406	2.9 × 10 ⁻²	7.5 × 10 ⁻³	1.5 × 10 ⁻³	2.3 × 10 ⁻¹	31
19	13	351	2.9 × 10 ⁻¹	8.6 × 10 ⁻²	1.4 × 10 ⁻³	2.4 × 10 ⁻¹	2.8
23	14	325	6.0 × 10 ⁻²	1.9 × 10 ⁻²	1.3 × 10 ⁻³	2.3 × 10 ⁻¹	12
28	18	218	1.3 × 10 ⁻²	5.6 × 10 ⁻³	1.3 × 10 ⁻³	2.7 × 10 ⁻¹	52

Column: ~2 × 15 mm, ~20 mg of AG50W-X4 resin
 Load: 830 μCi ²²⁵Ac and 1.1 μCi ²²⁵Ra in 100 μL of 0.03 M HNO₃
 Eluent: 200 μL of 0.15 M HI, Flow rate: ~0.5 mL/min

Table 2. Chelate conjugations of various monoclonal antibodies

MAB	[P] _i ¹ (mg/ml)	Chelate CHX-DTPA ²	(Ch/P) _i ³	(Ch/P) _f ³
273-34A	13.9	b	5	0.5
	8.9	b	10	1.9
	8.9	b	20	2.9
	9.8	a	10	0.6
	9.3	a	10	1.4
411-201B	19.9	b	10	1.1
	13.3	a	10	1.3
135-14	10.7	b	5	0.8
	11.3	b	10	1.4
	10.3	a	10	1.2

pH: 8.6, Temperature: 22°C, Reaction time: 16 h.

¹ [P]_i: Initial protein concentration.

² a and b refer to two isomers of CHX-DTPA, see Ref. [12].

³ (Ch/P)_i and (Ch/P)_f: Initial and final chelate to protein ratio, respectively.

Table 3. Radiolabeling as a function of time

Rxn time (min)	n	Radiolabeling yield (%)	Radioactivity recovery (%)
2	1	39.4	94.2
3	1	59.9	90.7
5	2	79.8 ± 1.7	101 ± 2
10	5	77.8 ± 6.1	95.8 ± 4.1
12	1	73.9	94.3
15	2	82.1 ± 2.8	94.4 ± 4.6
			Av. 95.1 ± 3.4

Protein: CHX-b-201B, 100 μg, ch/p = 1.1

Reaction vol.: 400 μL

Temperature: 22°C

Reaction pH: 4.8–5.0

²¹³Bi with Ra, the Ac generator-load solution should contain low fraction of Ra.

Results of conjugations of three anti bodies 273-34A, 411-201B and 135-14 are summarized in Table 2. In general, consistent with previous observation, the final chelate-to-protein ratio is a linear function of the initial chelate-to-protein ratio [13]. For

Table 4. Radiolabeling as a function of temperature

Rxn temp. (°C)	n	Radiolabeling yield (%)	Radioactivity recovery (%)
22	5	77.8 ± 6.1	95.8 ± 4.1
30	4	81.4 ± 4.6	98.7 ± 1.8
40	2	86.5 ± 1.9	100 ± 5

Protein: CHX-b-201B, 100 μg, ch/p = 1.1

Reaction vol.: 400 μL

Reaction time: 10 min

Reaction pH: 4.8–5.0

example, in the case of 34A antibody and CHX-b-DTPA chelate, for an initial chelate-to-protein ratio of 10, protein concentration of 8.9 mg/ml, pH of 8.6 and 16-h incubation, the final chelate-to-protein ratio was 1.9. Under similar conditions but (Ch/P)_i = 20, the final chelate-to-protein ratio of was 2.9. Increasing the (Ch/P)_i above 15 resulted in aggregation of proteins (34A and 201B) as measured by HPLC. Results of radiolabeling at room temperature as a function of reaction time is shown in Table 3. Within the first 5 min, the labeling yield increases rapidly to ~80% but then it remains rather constant. The effect of temperature on radiolabeling yield is shown in Table 4. For a 10-min reaction time, the labeling yield increases only 11% when reaction temperature increased by almost a factor of 2, from 22 to 40°C.

Results of labeling as a function of protein concentration are summarized in Table 5. The radiolabeling yield remains ~75% when the concentrations of chelated protein [with (CL/P)_f = 1.1] in the reaction mixture were 125–250 μg/mL. Further decrease in concentration of chelated protein resulted in a decrease in radiolabeling yield. When the concentration of chelated protein was 25 μg/mL, the yield was only 22%. The ratio of ²¹³Bi (μCi) incorporated per μg of protein also decreased from 4.5 to 1.6 as concentration of conjugated protein increased tenfold, from 25 to 260 μg/mL (Table 5, column 5). In these experiments the total concentration of protein was kept constant at 250 μg/mL by addition of unchelated antibody. Bi-213 occu-

Table 5. Radiolabeling as a function of protein concentration

Chelated protein (μg)	<i>n</i>	Labeling yield (%)	Activity recovery (%)	^{213}Bi to protein ($\mu\text{Ci}/\mu\text{g}$)	Sites occupied (%)
10	1	22.4	95.1	4.5	7×10^{-2}
25	1	35.6	94.6	2.8	2×10^{-3}
50	1	74.1	94.6	3.0	4×10^{-3}
75	1	73.5	93.4	2.0	5×10^{-3}
100	5	77.8 ± 6.1	95.8 ± 4.1	1.6	7×10^{-3}

Chelated protein: CHX-b-201B, $\text{ch7p} = 1.1$

Reaction vol.: 400 μL

Reaction pH: 4.8–5.0

^{213}Bi Sp. Act.: 2×10^7 $\mu\text{Ci}/\mu\text{g}$

Total protein: 100 μg

Temperature: 22°C

Total activity: 200 μCi

Reaction time: 10 min

pies only 0.1% of available sites on chelated antibody, which does not explain why quantitative labeling could not be achieved (Table 5, column 6). This calculation is based on the assumption that these ligands bond to only one ^{213}Bi ion (a theoretical specific activity of 2×10^7 $\text{mCi}/\mu\text{g}$ for ^{213}Bi was used). The problem most likely lies with the presence of common metal ion impurities at the part per billion level in chemical reagents. Even though great care was taken to eliminate these ions, certain ions with strong affinity for DTPA, such as Fe(III), even at concentrations below the detection limits of common analytical instrumentation can compete with ^{213}Bi for the available sites on the protein. The immunoreactivity of the ^{213}Bi -labeled 201B and 34A were preserved as indicated by the *in vivo* experiments where 50% of the total activity is delivered to the target organ [6].

In support of our on-going *in vivo* experiments, over one hundred labelings have been performed using ten generators at levels of 1–3 mCi . Our observations of the radiolytic effects of ^{225}Ac and its decay products on the shelf-life of the generator can be summarized as follows: Within a week of loading a new generator, a dark band appears on the top of the resin, and it progressively darkens. If the generator is not eluted regularly (at least once a day), in a few days the flow of liquid is totally obstructed, presumably due to re-polymerization of the resin's radiation-induced degradation byproducts. On the contrary, the generators perform well, with no significant reduction in labeling yields, when they are regularly eluted. In a few instances, reasonable labeling yields (~60%) were obtained from the two-week old generators which had been eluted extensively (2–3 times a day). These observations are consistent with the fact that the decay daughters of ^{225}Ac contribute significantly to the total radiation damage of the resin and by removing them on a regular basis the generator shelf-life can be extended.

Bi-213 was attached to monoclonal antibodies using isothio-cyanatobenzyl derivatives of CHX-

DTPA chelating ligands [12]¹. These chelating ligands contain a protein binding group that is distinct from the metal-chelating group. The SCN group on these ligands reacts with ϵ -amino groups, predominately on lysine side chains of immunoglobulins, with formation of a thiourea group. Systematic study of the chemical factors which influence binding of the SCN-Bzl-DTPA to protein has been reported earlier [13]. A pivotal issue in designing an optimal radiotherapeutic reagent is the chemical stability of the metal chelate system. The complexes of Bi^{+3} ions with eight-coordinated DTPA are kinetically inert in aqueous solutions with the overall equilibrium constant of $4 \times 10^{35} \text{ M}^{-1}$ (at 20°C and 0.1 *M* ionic strength, [17]). The *in vivo* stability of ^{212}Bi -CHX-DTPA antibody (anti-Tac) has also been demonstrated earlier [5] and the *in vivo* stability of ^{213}Bi labeled 34A and 201B antibodies has been reported by us in these proceedings [6].

Acknowledgement

The authors wish to thank Dr. M. Brechbiel and late Dr. O. A. Gansow at the National Institutes of Health for providing CHX-DTPA. The authors further acknowledge Patricia Lankford and Arnold Beets for technical assistance, Drs. Chuanchu Wu and Keyhan Gharmestani at NIH for helpful discussions on protein labeling and radiochemistry, Lane Bray and Drs. Robert E. Schenter and Thomas S. Teforde at PNNL for providing a portion of the Ra/Ac used in our studies. Bradley D. Patton, Emory D. Collins and Dr. Russ Knapp, Jr. are acknowledged for their continuous support and interest. This research was supported by ORNL Laboratory Directed Research and Development (LDRD), under auspices of U.S. Department of Energy under contract DE-AC05-96OR22464 with Lockheed Martin Energy Research Corporation.

References

- Bloomer, W. D., McLaughlin, W. H., Lambrecht, R. M., Atcher, R. W., Mirzadeh, S., Madara, J. L., Milius, R. A., Zalutsky, M. R., Adelstein, S. J., Wolf, A. P.: At-211 Radiocolloid Therapy: Further Observations and Comparisons with Radiocolloids of P-32, Dy-165, and Y-90. *Int. J. Radiat. Oncol. Biol. Phys.* **10**, 341 (1984).
- Ruegg, C. L., Anderson-Berg, W. T., Brechbiel, M. W., Mirzadeh, S., Gansow, O. A., Strand, M.: Improved *in vivo* Stability and Tumor Targeting of Bismuth-Labeled Antibody. *Cancer Res.* **50**, 4221 (1990).
- Huneke R. B., Pippin C. G., Squire R. A., Brechbiel, M. W., Gansow, O. A., Strand, M.: Effective Alpha-particle-mediated Radioimmunotherapy of Murine Leukemia. *Cancer Res.* **52**, 5818 (1992).
- Junghans, R. P., Dobbs, D., Raubitschek, A. A., Brechbiel, M. W., Mirzadeh, S., Gansow, O. A., Waldmann, T. A.: Pharmacokinetics and Bioactivity of DOTA-Bismuth Conjugated Anti-Tac Antibody for Alpha Emitter Therapy. *Cancer Res.* **53**, 5683 (1993).

¹ Macrocytic DOTA although offers somewhat higher stability with Bi(III); its bifunctional derivative is unavailable in quantities required for our *in vivo* studies [4, 16].

5. Hartmann, F., Horak, E. M., Garmestani, K., Wu, C., Brechbiel, M. W., Kozak, R. W., Tso, J., Kosteiny, S. A., Gansow, O. A., Nelson, D. L., Waldmann, T. A.: Radioimmunotherapy of Nude Mice Bearing a Human Interleukin 2 Receptor α -expressing Lymphoma Utilizing the α -emitting Radionuclide-conjugated Monoclonal Antibody ^{212}Bi -anti-Tac. *Cancer Res.* **54**, 4362 (1994).
6. Kennel, S. V., Mirzadeh, S.: Vascular Targeting for Radioimmunotherapy with ^{213}Bi . *Radiochim. Acta* **79**, 87 (1997).
7. Lambrecht, R. M., Mirzadeh, S.: Cyclotron Isotopes and Radiopharmaceuticals, XXXV. Astatine-211. *Int. J. Appl. Radiat. Isot.* **36**, 443 (1985).
8. Friedman, A. M.: *Therapy in Nuclear Medicine*, (R. P. Spencer, ed.), Grune and Stratton, New York 1978, pp. 139–144.
9. Atcher, R. W., Hines, J. J., Friedman, A. M.: A Remote System for the Separation of ^{228}Th and ^{224}Ra . *J. Radioanal. Nucl. Chem. Lett.* **117**, 155 (1987).
10. Mirzadeh, S., Schenter, R. E., Callahan, A. P., Knapp, F. F.: Production Capabilities in U.S. Nuclear Reactors for Medical Radioisotopes, **ORNL/TM-12010** (1992).
11. Kennel, S. J., Lee, R., Boltman, S., Kabalka, G.: Rat Monoclonal Antibody Distribution in Mice. An Epitope Inside the Vascular Space Mediated Very Efficient Localization. *Nucl. Med. Biol.* **17**, 193 (1990).
12. Brechbiel, M. W., Gansow, O. A.: Synthesis of C-Functionalized *trans*-Cyclohexyldiethylenetriaminepentaacetic Acids for Labeling of Monoclonal Antibodies with the Bismuth-212 α -Particle Emitter. *J. Chem. Soc. Perkin Trans. 1*, 1173 (1992).
13. Mirzadeh, S., Brechbiel, M. W., Gansow, O. A.: Radiometal Labeling of Immunoproteins: Covalent Linkage of 2-(4-isothiocyanatobenzyl)-DTPA to Immunoglobulin. *Bioconjugate Chem.* **1**, 59 (1990).
14. Pippin, C. G., Parker, T. A., McMurry, T. J., Brechbiel, M. W.: Spectroscopic Method for the Determination of a Bifunctional DTPA Ligand in DTPA Monoclonal Antibody. *Bioconjugate Chem.* **3**, 342 (1992).
15. Dadachova, E., Mirzadeh, S., Smith, S. V., Knapp, F. F. Jr., Hetherington, E. L.: Radiolabeling Antibodies with Holmium-166. *Appl. Radiat. Isot.* **48**, 477 (1997).
16. Mirzadeh, S., Kumar, K., Gansow, O. A.: The Chemical Fate of ^{212}Bi -DOTA Formed by β -Decay of $^{212}\text{Pb}(\text{DOTA})^{2-}$ Complex. *Radiochim. Acta* **60**, 1–10 (1993), and references within.
17. Martell, A. E., Smith, R. M.: *Critical Stability Constant, Vol. 1, Amino Acids*, Pergamon Press, NY 1974, p. 285.

