

1-1-2011

Power Quality Improvement in Autonomous Microgrid Operation Using Particle Swarm Optimization

Waleed Al-Saedi
Edith Cowan University

Stefan W. Lachowicz
Edith Cowan University

Daryoush Habibi
Edith Cowan University

Octavian Bass
Edith Cowan University

Follow this and additional works at: <https://ro.ecu.edu.au/ecuworks2011>



Part of the [Power and Energy Commons](#)

This is an Author's Accepted Manuscript of: Al-Saedi, W. , Lachowicz, S. W., Habibi, D. , & Bass, O. (2011). Power quality improvement in autonomous microgrid operation using particle swarm optimization. Paper presented at the 2011 IEEE Innovative Smart Grid Technologies Asia. Perth, Australia. Available [here](#)

© 2011 IEEE. Personal use of this material is permitted. Permission from IEEE must be obtained for all other uses, in any current or future media, including reprinting/republishing this material for advertising or promotional purposes, creating new collective works, for resale or redistribution to servers or lists, or reuse of any copyrighted component of this work in other works.

This Conference Proceeding is posted at Research Online.

<https://ro.ecu.edu.au/ecuworks2011/825>

Power Quality Improvement in Autonomous Microgrid Operation Using Particle Swarm Optimization

Waleed Al-Saedi, *Student Member, IEEE*, Stefan W. Lachowicz, *Senior Member, IEEE*, Daryoush Habibi, *Senior Member, IEEE*, and Octavian Bass, *Senior Member, IEEE*

Abstract—This paper presents an optimal power control strategy for an autonomous microgrid operation based on a real-time self-tuning method. The purpose of this work is to improve the quality of power supply where Distributed Generation (DG) units are connected to the grid. Dynamic response and harmonics distortion are the two main performance parameters which are considered in this work, particularly when the microgrid is islanded. The controller scheme is composed of an inner current control loop and an outer power control loop based on a synchronous reference frame and the conventional PI regulators. Particle Swarm Optimization (PSO) is an intelligent searching algorithm that is applied for real-time self-tuning of the system. The results show that the proposed controller provides an excellent dynamic response with acceptable harmonics level.

Index Terms—Microgrid, power controller, current controller, Particle Swarm Optimization (PSO).

I. INTRODUCTION

THE microgrid is a cluster of DG units that interface with electrical distribution network using power electronic devices such as Voltage Sourced Inverter (VSI). Recently, this scenario represents a complementary infrastructure to the utility grid due to the rapid increase of the load demand. The microgrid can operate in two modes; grid-connected mode and islanding mode. Moreover, the high penetration of the micro-sources such as wind, photovoltaic, hydro, and fuel cell emerge as an alternative which provides green energy and flexible extension to the utility grid [1]. However, these sources are usually interconnected by widely used Pulse-Width-Modulation (PWM)-VSI systems which have nonlinear voltage-current characteristics of semiconductor components, and produce high switching frequency, both of which affect the quality of the power supply [2].

Fig. 1 shows an example of a microgrid system. In such system, a robust control strategy is required to achieve high performance operation and meet power quality requirements by which DG units are connected to the grid. Therefore, the current control strategy of the PWM-VSI system is one of the most important aspects of the modern power electronics converters. There are two main categories for current controllers: nonlinear controllers based on closed loop current type PWM and linear controllers based on open loop voltage type PWM, and both are applied using the inner current feedback loop [3].

In the nonlinear controller, hysteresis current control (HCC) is commonly used for 3-phase grid-connected VSI system.

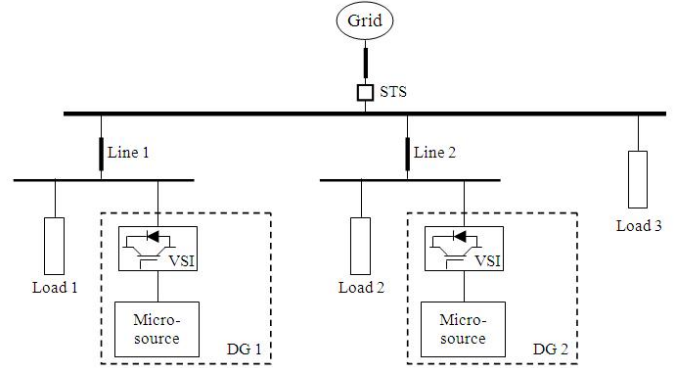

Fig. 1. An example of microgrid system

The HCC compensates the current error and generates PWM signals with acceptable dynamic response. While the current is controlled independently with a control delay, zero voltage vectors cannot be generated thus resulting in a large current ripple with high total harmonic distortion (THD) [4]. However, linear current controller based space vector PWM (SVPWM) is an adequate controller which compensates the current error either by proportional-integral (PI) regulator or predictive control algorithm while the compensation and PWM generation can be done separately. This controller yields excellent steady-state response, low current ripple, and a high-quality sinusoidal waveform [5]. An outer power control loop is usually integrated with the current control loop to release the reference voltage signals to the PWM module. In a synthetic control scheme, the power control strategy plays a key role to satisfy the power quality requirements. The DG unit can adopt one of the two typical power control strategies; active-reactive power control strategy in grid-connected mode, and voltage-frequency control strategy in islanding mode. In this case, the DG unit is expected to supply maximum power and maintain system stability [6].

The theoretical foundation of the power control strategy based on inner current loop is illustrated in [7]; the controller is implemented with the aim of ensuring the dynamic stability of the system and providing all the information needed for analysis and design. In [8] and [9], the power control strategy was applied for a microgrid system to analyse and compare the two power control strategies. The dynamic performance and load sharing were considered, the controller was described in detail, but the process lacked automatic tuning of the control parameters during abrupt changes.

The authors are with the School of Engineering, Faculty of Computing, Health and Science, Edith Cowan University, Perth, Western Australia (e-mail: walsaed@our.ecu.edu.au, s.lachowicz@ecu.edu.au, d.habibi@ecu.edu.au, and o.bass@ecu.edu.au).

In this paper, a power controller based real-time optimization is proposed for an autonomous microgrid. This controller is interfaced with the current control loop based on a synchronous reference frame. The conventional PI regulators are utilized in this work, and feed-forward compensation is applied to the inner control loop to achieve a high dynamic response. The DG unit adopts voltage-frequency (Vf) power control strategy when the microgrid is islanded. Particle Swarm Optimization (PSO) algorithm is used for real-time self-tuning parameters, with Integral Time Absolute Error (ITAE) as an objective function that calculates Simpson's 1/3 rule. The aim of this work is to improve the power supply by achieving low harmonics distortion and fast dynamic response.

II. SYSTEM DESCRIPTION

A. Three-Phase Grid-Connected VSI Model

A typical model of a three-phase grid-connected VSI with an LC filter is depicted in Fig. 2, where R_s and L_s represent the equivalent lumped resistance and inductance of the filter, the coupling transformer if applicable, and the grid as detected by the inverter. C is the filter capacitance and V_s is the grid voltage.

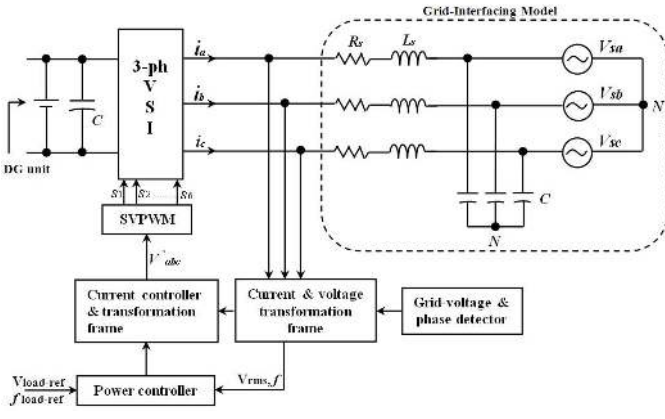

Fig. 2. 3-phase grid-connected VSI system

In the abc reference frame, the state space equations of the system equivalent circuit are given by [10]:

$$\frac{d}{dt} \begin{bmatrix} i_a \\ i_b \\ i_c \end{bmatrix} = \frac{R_s}{L_s} \begin{bmatrix} i_a \\ i_b \\ i_c \end{bmatrix} + \frac{1}{L_s} \left(\begin{bmatrix} V_{sa} \\ V_{sb} \\ V_{sc} \end{bmatrix} - \begin{bmatrix} V_a \\ V_b \\ V_c \end{bmatrix} \right) \quad (1)$$

Using Park's transformation, equation (1) can be expressed in the dq reference frame as:

$$\frac{d}{dt} \begin{bmatrix} i_d \\ i_q \end{bmatrix} = \begin{bmatrix} -\frac{R_s}{L_s} & \omega \\ \omega & -\frac{R_s}{L_s} \end{bmatrix} \begin{bmatrix} i_d \\ i_q \end{bmatrix} + \frac{1}{L_s} \left(\begin{bmatrix} V_{sd} \\ V_{sq} \end{bmatrix} - \begin{bmatrix} V_d \\ V_q \end{bmatrix} \right) \quad (2)$$

where ω is the coordinate angular frequency, and the Park's transformation can be defined as:

$$i_{dq0} = T i_{abc} \quad (3)$$

where;

$$i_{dq0} = \begin{bmatrix} i_d \\ i_q \\ i_0 \end{bmatrix}, \quad i_{abc} = \begin{bmatrix} i_a \\ i_b \\ i_c \end{bmatrix} \quad (4)$$

$$T = \frac{2}{3} \cdot \begin{bmatrix} \cos\theta & \cos(\theta - \frac{2\pi}{3}) & \cos(\theta + \frac{2\pi}{3}) \\ -\sin\theta & -\sin(\theta - \frac{2\pi}{3}) & -\sin(\theta + \frac{2\pi}{3}) \\ \frac{1}{2} & \frac{1}{2} & \frac{1}{2} \end{bmatrix} \quad (5)$$

$\theta = \omega_s t + \theta_0$ is the synchronous rotating angle, the subscript "0" represents the initial value.

B. Control System Configuration

The proposed power controller based PSO algorithm is presented in Fig. 3. This controller should respond to the sudden changes such as starting the islanding operation mode or load change. In this work, the DG unit adopts the Vf power control strategy when the microgrid is islanded. The system voltage and frequency are regulated by two PI regulators which operate based on the selected optimal parameters by PSO algorithm to produce the reference current vectors i_d^* and i_q^* .

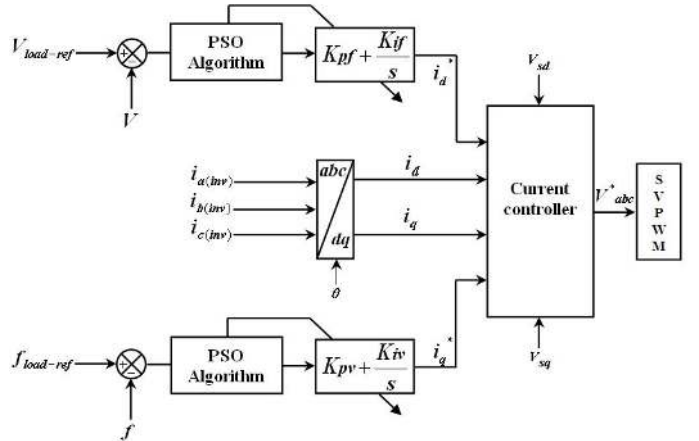

Fig. 3. The proposed power controller scheme

Fig. 4 shows the block diagram of the current control loop which is designed based on a synchronous reference frame. This controller is usually used to form the applied voltage on the inductive $R-L$ impedance, so an impulse current in the inductor has a minimum current error. The Phase-Locked-Loop (PLL) block is required to detect the voltage phase angle in order implement Park's transformation in the control scheme. Two PI regulators are used to eliminate current error. Consequently, the output signals of the controller represent the reference voltage signals in the dq frame, followed by the inverse Park's transformation to generate six pulses by SVPWM in order to fire the Insulated-gate Bipolar Transistor (IGBT) inverter.

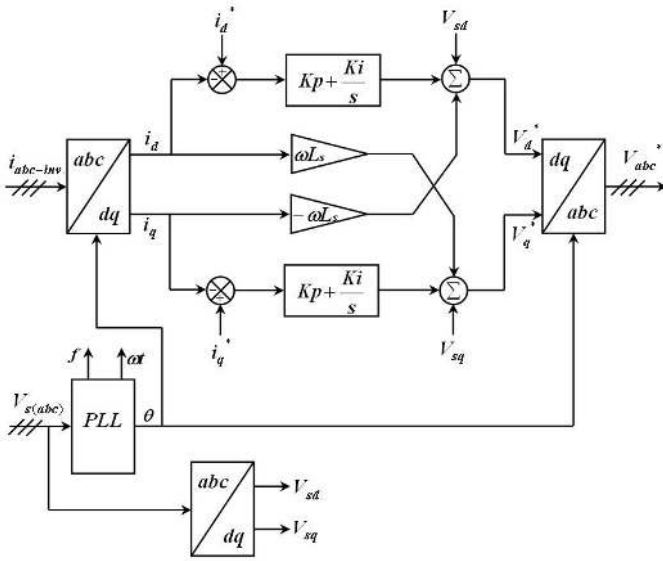

Fig. 4. The inner current controller loop

In the synchronous dq frame, based on (2), the reference voltage signals can be expressed:

$$\begin{bmatrix} V_d^* \\ V_q^* \end{bmatrix} = \begin{bmatrix} -K_p & -\omega L_s \\ \omega L_s & -K_p \end{bmatrix} \begin{bmatrix} i_d \\ i_q \end{bmatrix} + \begin{bmatrix} K_p & 0 \\ 0 & K_p \end{bmatrix} \begin{bmatrix} i_d^* \\ i_q^* \end{bmatrix} + \begin{bmatrix} K_i & 0 \\ 0 & K_i \end{bmatrix} \begin{bmatrix} X_d \\ X_q \end{bmatrix} + \begin{bmatrix} V_{sd} \\ V_{sq} \end{bmatrix} \quad (6)$$

where the superscript “*” denotes the reference values, $\frac{dX_d}{dt} = i_d^* - i_d$, and $\frac{dX_q}{dt} = i_q^* - i_q$

C. Particle Swarm Optimization (PSO) Algorithm

The Particle Swarm Optimization (PSO) algorithm was proposed by Kennedy and Eberhart in 1995 [11]. It can be defined as an Evolutionary Computation (EC) technique that simulates the social behavior of the swarm in nature such as schools of fish or flocks of birds where they find food together in a specific area. In other words, PSO is an iterative algorithm that searches the space to determine the optimal solution for an objective function (fitness function). The PSO algorithm evaluates itself based on the movement of each particle as well as the swarm collaboration. Each particle starts to move randomly based on its own best knowledge and the swarm’s experience. It is also attracted toward the location of the current global best position X_{gbest} and its own best position X_{pbest} [12]. The basic rules of the PSO algorithm can be explained in three main stages:

- 1) Evaluating the fitness value of each particle.
- 2) Updating local and global best fitness and positions.
- 3) Updating the velocity and the position of each particle.

Mathematically, the search process can be expressed by simple equations using the position vector $X_i = [x_{i1}, x_{i2}, \dots, x_{in}]$ and the velocity vector $V_i = [v_{i1}, v_{i2}, \dots, v_{in}]$ in the specific dimensional search space. In addition, the optimality of the solution in the PSO algorithm depends on each particle position and velocity update using the following equations [13]:

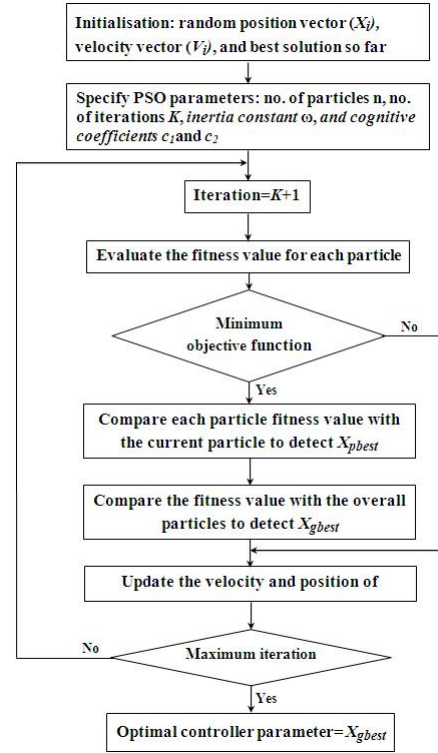

Fig. 5. Flowchart of the applied PSO algorithm

$$V_i^{k+1} = w.V_i^k + c_1.r_1[X_{pbest}^k - X_i^k] + c_2.r_2[X_{gbest}^k - X_i^k] \quad (7)$$

$$X_i^{k+1} = X_i^k + V_i^{k+1} \quad (8)$$

where i is the index of the particle; V_i^k, X_i^k are the velocity and position of particle i at iteration k , respectively; w is the inertia constant and is often in the range $[0 \ 1]$; c_1 and c_2 are coefficients which are usually between $[0 \ 2]$; r_1 and r_2 are random values which are generated for each velocity update; X_{gbest} and X_{pbest} are the global best position that is achieved so far, based on the swarm’s experience, and local best position of each particle that is achieved so far, based on its own best position, respectively.

A confined search space is the main limitation of the PSO algorithm. Limited search space provides a fast solution, but it influences the optimality of the solution if the global optimum value is located outside the boundaries. However, extended boundaries allow finding global optimum results, but need more time to determine the global optimal value in the search space. Therefore, more information about the limits of the parameters will help to determine the search boundaries. Fig. 5 shows the flowchart of the applied PSO algorithm.

D. Objective Function

The objective function is a particular criterion that is used to evaluate the particle’s positions. In this paper, the controller’s fitness function is based on $ITAE$ which is calculated using

TABLE I
THE APPLIED PSO PARAMETERS

PSO parameters description	K_{pf}	K_{if}	K_{pv}	K_{iv}
Acceptable violation (p.u.)	± 0.01		± 0.1	
Initial velocity (V)	0		0	
Initial fitness value (best so far)	800		800	
Inertia constant (w)	0.05	0.5	0.05	0.5
Cognitive coefficients (c_1 & c_2)	0.09	0.1	0.09	0.1

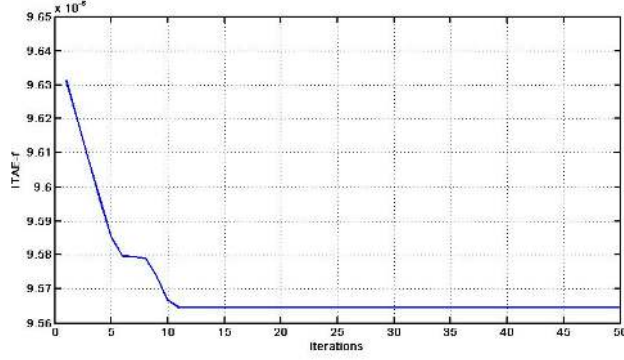

Fig. 6. Fitness values of the frequency control objective

Simpson's 1/3 rule. The mathematical expression of the $ITAE$ performance index is defined by the following expression [14]:

$$ITAE = \int_0^{\infty} t|e(t)|dt \quad (9)$$

where t is the time and $e(t)$ is the difference between the reference set point and the controlled signal.

E. Termination Criteria

In general, the termination criteria of a PSO algorithm can be either when the algorithm completes the maximum number of iterations or achieves an acceptable fitness value. In this work, the minimization of the objective function is considered with the maximum number of iterations to find optimum power control parameters. The number of particles and iterations are set to 50, and the rest of the PSO algorithm parameters are listed in Table I. Thereby, the final optimal power control parameters are as follows:

$$K_{pf} = 3.0108590, K_{if} = 0.0003778$$

$$K_{pv} = -0.9936928, K_{iv} = 0.0033777$$

The performance of the PSO search process is shown in Fig. 6 and 7. It can be seen that the error decreases rapidly with the number of iterations and the solution is steady towards the end. Fig. 8, 9, 10, and 11 depict the movement behavior of the particles. The results show that the particles finish their movement above the best positions.

III. SIMULATION RESULTS

The model of a three-phase grid-connected VSI system and the proposed controller as shown in Fig. 2 are simulated using

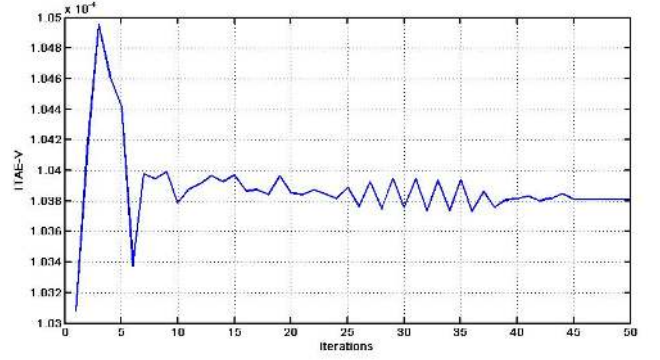

Fig. 7. Fitness values of the voltage control objective

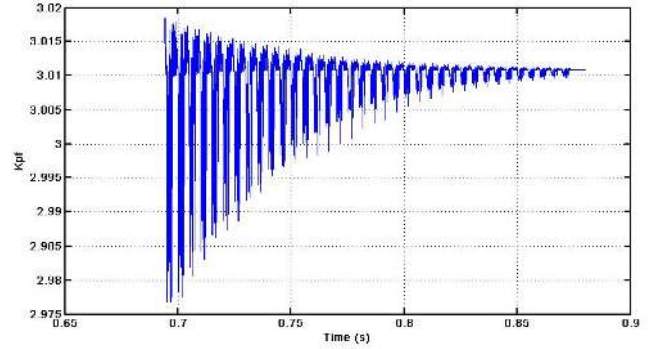

Fig. 8. Search process of K_{pf} when the system is islanded

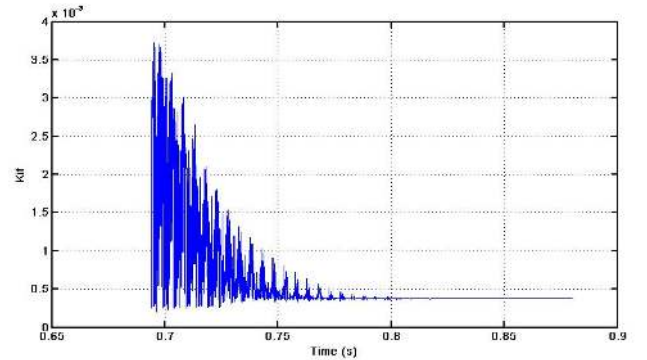

Fig. 9. Search process of K_{if} when the system is islanded

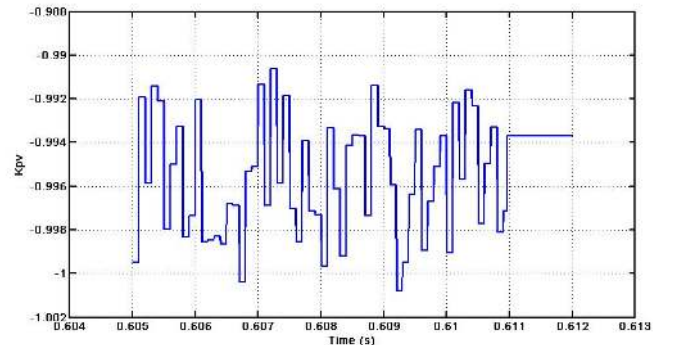

Fig. 10. Search process of K_{pv} when the system is islanded

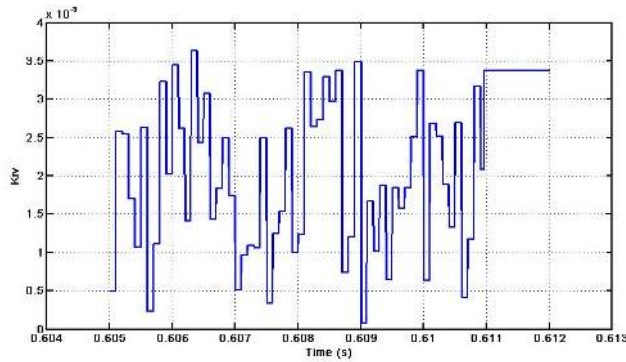

Fig. 11. Search process of K_{iv} when the system is islated

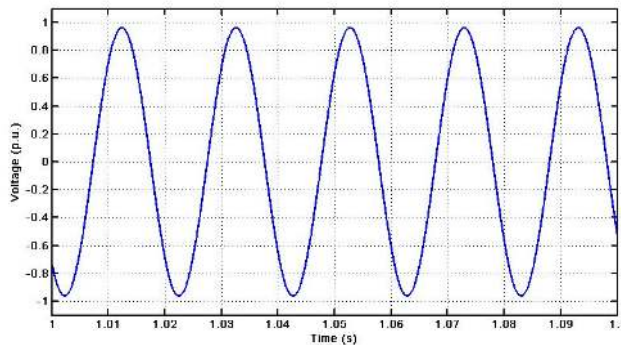

Fig. 12. Simulation results of phase voltage

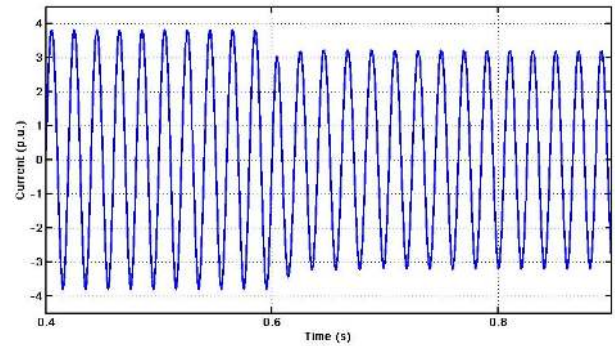

Fig. 13. System dynamic response at 0.6 seconds

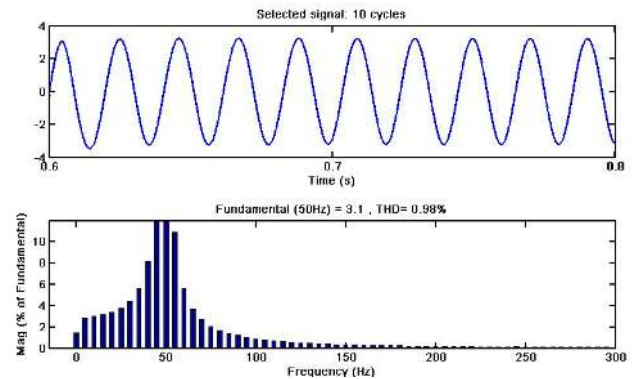

Fig. 14. Spectrum of the line current

MATLAB/Simulink environment. The model parameters are defined as follows: $L_s = 5$ mH, $R_s = 1.4$ Ω , $f = 50$ Hz, filter capacitance $C = 1500$ μ F, and the input capacitor of the dc side is 5000 μ F. The output power of the DG unit is 50 kW. For the SVPWM-based current controller, switching and sampling frequency are fixed at 10 kHz and 500 kHz, respectively. All simulation results are in a p.u. system.

The simulation starts in grid-connected mode. Then, the system is islated at 0.6 sec. Fig. 12 shows that the proposed controller achieves high-quality sinusoidal waveforms and maintains a steady-state response. The dynamic response of the inverter output current when the system is islated is shown in Fig. 13. Clearly, the controller provides an excellent dynamic response.

Fig. 14 shows the spectrum of the line current. The results prove that the proposed control strategy compensates current harmonic distortion effectively. The total harmonic distortion (THD) is 0.98% which is well below the 5% THD allowed in the IEEE Std 1547-2003 [15].

IV. CONCLUSION

In this paper, an optimal power control strategy has been proposed for an autonomous microgrid operation. The control strategy utilizes two control loops; the inner current control loop, and the outer power control loop. A PSO algorithm is incorporated in the (Vf) power control strategy in order to implement real-time self-tuning, especially when the microgrid is islated from the grid. The simulation results show that the

proposed controller offers fast dynamic response and achieves a satisfactory level of harmonics distortion.

REFERENCES

- [1] R. H. Lasseter, "Microgrids," in *Power Engineering Society Winter Meeting, 2002. IEEE*, vol. 1, pp. 305–308 vol.1.
- [2] R. Strzelecki and G. Benysek, *Power electronics in smart electrical energy networks*. Verlag London: Springer, 2008.
- [3] Z. Qingrong and C. Liuchen, "Study of advanced current control strategies for three-phase grid-connected pwm inverters for distributed generation," in *Control Applications, 2005. CCA 2005. Proceedings of 2005 IEEE Conference on*, pp. 1311–1316.
- [4] K. Bong-Hwan, M. Byung-Duk, and Y. Jang-Hyoun, "An improved space-vector-based hysteresis current controller," *Industrial Electronics, IEEE Transactions on*, vol. 45, no. 5, pp. 752–760, 1998.
- [5] M. P. Kazmierkowski and L. Malesani, "Current control techniques for three-phase voltage-source pwm converters: a survey," *Industrial Electronics, IEEE Transactions on*, vol. 45, no. 5, pp. 691–703, 1998.
- [6] Y. Wei, Z. Chengyong, L. Yi, and L. Gang, "A scheme of connecting microgrid to ac grid via flexible power electronics interface," in *Power System Technology (POWERCON), 2010 International Conference on*, pp. 1–6.
- [7] D. Wei, T. Xisheng, and Q. Zhiping, "Research on dynamic stability of hybrid wind/pv system based on micro-grid," in *Electrical Machines and Systems, 2008. ICEMS 2008. International Conference on*, pp. 2627–2632.
- [8] Y. Wang, Z. Lu, and M. Yong, "Analysis and comparison on the control strategies of multiple voltage source converters in autonomous microgrid," in *Developments in Power System Protection (DPSP 2010). Managing the Change, 10th IET International Conference on*, pp. 1–5.
- [9] R. BiYing, T. XiangQian, T. Sha, and S. XiangDong, "Research on the control strategy of inverters in the micro-grid," in *Power and Energy Engineering Conference (APPEEC), 2010 Asia-Pacific*, pp. 1–4.

- [10] C. Il-Yop, L. Wenxin, D. A. Cartes, and K. Schoder, "Control parameter optimization for a microgrid system using particle swarm optimization," in *Sustainable Energy Technologies, 2008. ICSET 2008. IEEE International Conference on*, pp. 837–842.
- [11] J. Kennedy and R. Eberhart, "Particle swarm optimization," in *Neural Networks, 1995. Proceedings., IEEE International Conference on*, vol. 4, pp. 1942–1948 vol.4.
- [12] Yang and Xin-She, *Engineering optimization: An introduction with metaheuristic application*. Hoboken: John Wiley, 2010.
- [13] Y. del Valle, G. K. Venayagamoorthy, S. Mohagheghi, J. C. Hernandez, and R. G. Harley, "Particle swarm optimization: Basic concepts, variants and applications in power systems," *Evolutionary Computation, IEEE Transactions on*, vol. 12, no. 2, pp. 171–195, 2008.
- [14] D. Maiti, A. Acharya, M. Chakraborty, A. Konar, and R. Janarthanan, "Tuning pid controllers using the integral time absolute error criterion," in *Information and Automation for Sustainability, 2008. ICIAS 2008. 4th International Conference on*, pp. 457–462.
- [15] "Ieee standard for interconnecting distributed resources with electric power systems," *IEEE Std 1547-2003*, 2003.

V. BIOGRAPHIES



Octavian Bass (M'06, SM'10) was born in Oradea in Romania, on September 30, 1971. He graduated from the "Politehnica" University of Timisoara, Romania, in 1995 and received his PhD from the same University in 2001. His employment history includes research positions at the Budapest University of Technology and Economics, Hong Kong Polytechnic University, Hull University UK, and Utsunomiya University, Japan. He was a lecturer at James Cook University, Queensland, Australia, from 2006 to 2009 and is currently a Senior Lecturer at Edith Cowan University, Western Australia. His fields of interest include smart grid technologies, renewable energy resources, power electronics, nonlinear dynamics and e-learning. He has co-authored 70 professional publications.



Waleed Al-Saedi (S'11) was born in Baghdad, Iraq, on May 1974. He received the B.Sc. degree in electrical engineering, Higher Diploma degree in Computer Aided Instructional Engineering, and the M.Sc. degree in electrical engineering from University of Technology, Baghdad, Iraq, in 1996, 2000, and 2004, respectively. His employment experience over 5 years included design electrical services of the numerous projects via Engineering Consultancy Bureau at the same University. He was a lecturer in the Department of Electro-mechanical Engineering at the same University from 2006 to 2008. Since March 2010, he has been pursuing the Ph.D. degree in electrical engineering at Edith Cowan University, Perth, Western Australia. His interested research area includes optimal control of power quality for microgrids using artificial intelligence.



Stefan Lachowicz (M'97, SM'04) was born in Lodz, Poland, on February 22, 1959. He received his MSEE and PhD in Electronic Engineering from the Technical University of Lodz, Poland, in 1981 and 1986 respectively. From 1986 until 1992 he was an assistant professor at the same university. In 1993 he joined School of Engineering at Edith Cowan University, Perth, Western Australia where he is a senior lecturer. He authored and co-authored about 80 scientific publications. His research interests include, smart energy systems, renewable energy sources, power electronics, and digital systems.



Daryoush Habibi (M'95, SM'99) graduated with a Bachelor of Engineering (Electrical) with First Class Honours from the University of Tasmania in 1989 and a PhD from the same University in 1994. His employment history includes Telstra Research Laboratories, Flinders University, Intelligent Pixels Inc., and Edith Cowan University, where he is currently a Professor and the Head of the School of Engineering. His research interests include engineering design for sustainable development, reliability and quality of service in communication systems and networks, smart energy systems, and environmental monitoring technologies. He is a Fellow of Engineers Australia, Electrical College Board member of Engineers Australia, ITEE College Board member of Engineers Australia, Editor-in-Chief of the Australian Journal of Electrical and Electronic Engineering, and Deputy President of the Australian Council of Engineering Deans.