

---

# Power Quality Improvement Using Switch Mode Regulator

---

Raju Ahmed and Mohammad Jahangir Alam

Additional information is available at the end of the chapter

<http://dx.doi.org/10.5772/53234>

---

## 1. Introduction

Power quality describes the quality of voltage and current. It is an important consideration in industries and commercial applications. Power quality problems commonly faced are transients, sags, swells, surges, outages, harmonics and impulses [1]. Among these voltage sags and extended under voltages have large negative impact on industrial productivity, and could be the most important type of power quality variation for many industrial and commercial customers [1-5].

Voltage sags is mainly due to the fault occurring in the transmission and distribution system, loads like welding and operation of building construction equipment, switching of the loaded feeders or equipments. Both momentary and continuous voltage sags are undesirable in complex process controls and household appliances as they use precision electronic and computerized control.

Major problems associated with the unregulated long term voltage sags include equipment failure, overheating and complete shutdown. Tap changing transformers with silicon-controlled rectifiers (SCR) are usually used as a solution of continuous voltage sags [6]. They require large transformer with many SCRs to control the voltage at the load which lacks the facility of adjusting to momentary changes. Some solutions have been suggested in the past to encounter the problems of voltage sag [7-11]. But these proposals have not been realized practically to replace conventional tap changing transformers.

Now a day's various power semiconductor devices are used to raise power quality levels to meet the requirements [12]. Several AC voltage regulators have been studied as a solution of voltage sags [13-18]. In [13] the input current was not sinusoidal, in [14-16] the efficiency of the regulator was not analyzed and in [17-18] the input power factor was very low and the efficiency is also found poor. Compact and fully electronic voltage regulators are still unavailable practically.

---

Dynamic Voltage Restorer (DVR) is sometimes used to regulate the load side voltage [19-21]. The DVR requires energy storage device to compensate the voltage sags. Flywheels, batteries, superconducting magnetic energy storage (SMES) and super capacitors are generally used as energy storage devices. The rated power operation of DVR depends on the size and capacity of energy storage device which limits its use in high power applications. Whereas, switching regulator needs no energy storage devices, therefore, can be used both in low power and high power applications.

The objective of this chapter is to describe the operation and design procedure of a switch mode AC voltage regulator. Firstly, some reviews of the regulators are presented then the procedure of design and analysis of a switch mode regulator is described step by step. Simulation software OrCAD version 9.1 [22] is used to analyze the regulator. The proposed regulator consists mainly two parts, power circuit and control circuit. The power circuit consist two bi-directional switches which serve as the freewheeling path for each other. A signal generating control circuit is to be associated with the power circuit for getting pulses of the switches. In the control circuit, a commercially available pulse width modulator IC chip SG1524B is used, thus circuit is compact and more viable.

## 2. Review of voltage regulators

### 2.1. Switching-mode power supply (SMPS)

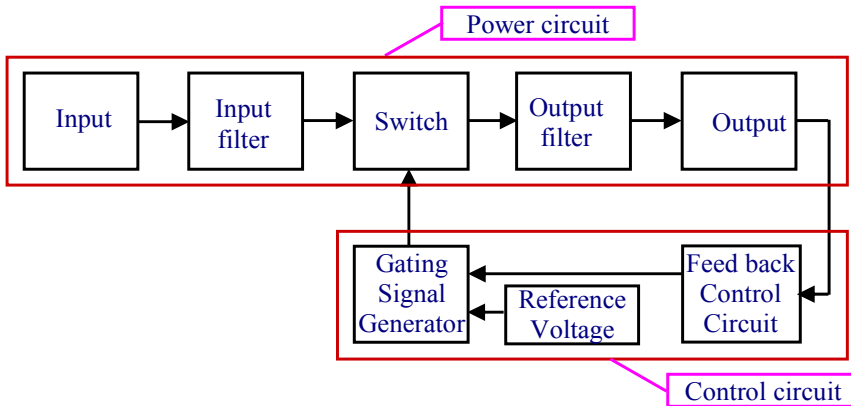
A switching-mode power supply (SMPS) is switched at very high frequency. Conversion of both step down and step up of voltage is possible using SMPS. Uses of SMPSs are now universal in space power applications, computers, TV and industrial units. SMPSs are used in DC-DC, AC-AC, AC-DC, DC-AC conversion for their light weight, high efficiency and isolated multiple outputs with voltage regulation. Main parts of a Switching-mode power supply are:

(a) Power circuit, (b) Control circuit.

Figure 1 shows the block diagram of a SMPS. The power circuit is mainly the input, output side with the switching device. The switching device is continuously switched at high frequency by the gate signal from the control circuit to transfer power from input to the output. The control circuit of a SMPS basically generates high frequency gating pulses for the switching devices to control the output voltage. Switching is performed in multiple pulse width modulation (PWM) fashion according to feedback error signal from the load. High frequency switching reduces filter requirements at the input and output sides of the converter. Simplest PWM control uses multiple pulse modulations generated by comparing a DC with a high frequency carrier triangular wave.

The PWM control circuit is commonly available as integrated form. The designer can select the switching frequency by choosing the value of RC to set oscillator frequency. As a rule of thumb to maximize the efficiency, the oscillation period should be about 100 times longer than the switching time of the switching device such as Transistor, Metal oxide semiconductor field-effect transistor (MOSFET), Insulated gate bipolar transistor (IGBT). For

example, if a switch has a switching time of 0.5  $\mu$ s, the oscillator period would be 50  $\mu$ s, which gives the maximum oscillation frequency of 20 KHz. This limitation is due to the switching loss in the switching devices. The switching loss of switching devices increases with the switching frequency. In addition, the core loss of inductor limits the high frequency operation.



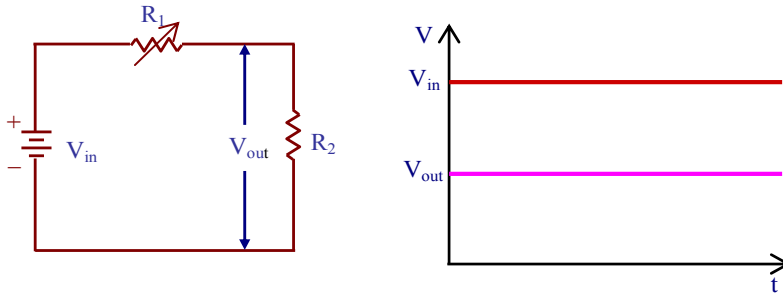
**Figure 1.** Block diagram of Switching-mode power supply (SMPS).

## 2.2. DC-DC converter

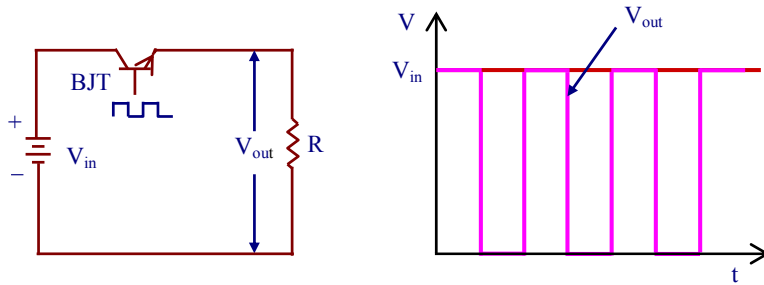
Figure 2 illustrates the circuit of a classical linear power converter. Here power is controlled by a series linear element; either a resistor or a transistor is used in the linear mode. The total load current passes through the series linear element. In this circuit greater the difference between the input and the output voltage, more is the power loss in the controlling device (linear element). Linear power conversion is dissipative and hence is inefficient.

The circuit of Fig. 3 illustrates basic principle of a DC-DC switching-mode power converter. The controlling device is a switch. By controlling the duty cycle, (the ratio of the time in on positions to the total time of on and off position of a switch) the power flow to the load can be controlled in a very efficient way. Ideally this method is 100% efficient. In practice, the efficiency is reduced as the switch is non-ideal and losses occur in power circuits. Hence, one of the prime objectives in switch mode power conversion is to realize conversion with the least number of components having better efficiency and reliability. The DC output voltage to the load can be controlled by controlling the duty cycle of the rectangular wave supplied to the base or gate of the switching device. When the switch is on, it has only a small saturation voltage drop across it. In the off condition the current through the switch is zero.

The output of the switch mode power conversion circuit (Fig. 3) is not pure DC. This type of output is applicable in some cases such as oven heating without proper filtration. If constant DC is required, then output of converter has to be smoothed out by the addition of low-pass filter.



**Figure 2.** Linear (dissipative) DC-DC power conversion circuit.



**Figure 3.** Switching-mode (non dissipative) DC-DC power conversion circuit.

### 2.2.1. Types of DC-DC converter

There are four basic topologies of switching DC-DC regulators:

- a. Buck regulator
- b. Boost regulator
- c. Buck-Boost regulator and
- d. Cûk regulator.

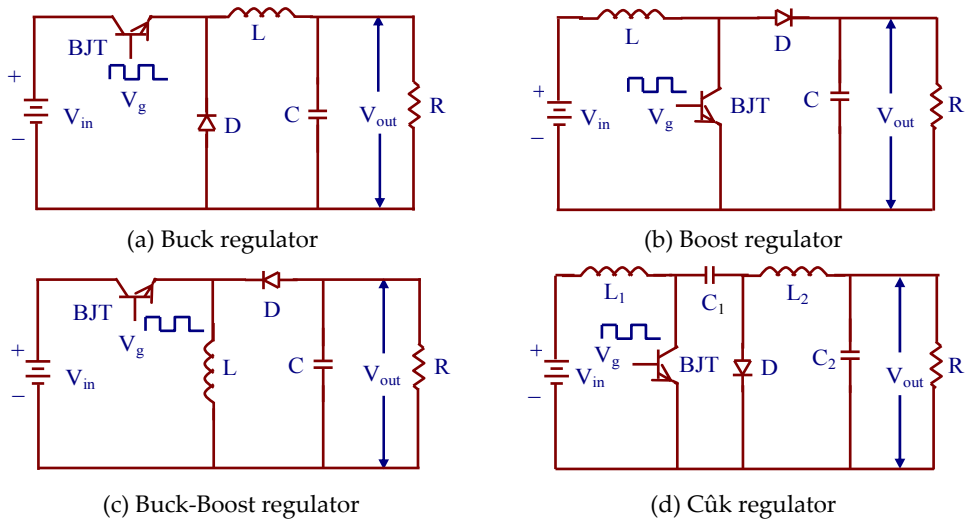
The Circuit diagram of four basic DC-DC switching regulators is shown in Fig. 4. The expression of output voltage for the four types of DC-DC regulators are as follows:

For Buck regulator,  $V_{out} = kV_{in}$ , For Boost regulator,  $V_{out} = \frac{V_{in}}{1-k}$

For Buck- Boost regulator and Cûk regulator,  $V_{out} = \frac{-kV_{in}}{1-k}$

Where  $k$  is the duty cycle, the value of  $k$  is less than 1. For Buck regulator output voltage is always lower than input voltage, for Boost regulator output voltage is always higher than input voltage. For Buck-Boost regulator and Cûk regulator output voltage is higher than input voltage when the value of  $k$  is higher than 0.5, and output voltage is lower than input voltage when the value of  $k$  is lower than 0.5. When  $k$  is equal to 0.5 output voltage is same

as input voltage. In Buck-Boost and Cûk regulator, the polarity of output voltage is opposite to that of the input voltage, therefore these regulators are also called inverting regulators.



**Figure 4.** Circuit diagram of DC-DC regulator, (a) Buck regulator, (b) Boost regulator, (c) Buck-Boost regulator, (d) Cûk regulator.

### 2.3. AC-AC converter

The AC voltage regulator is an appliance by which the AC output voltage can be set to a desired value and can be maintained constant all the time irrespective of the variations of input voltage and load. This subject is vast and the field of application extends from very large power systems to small electronic apparatus. Naturally, the types of regulators are also numerous. The design of the regulators depends mainly on the power requirements and degree of stability.

The AC voltage can be regulated by the following ways.

- Solid-state tap changer and steeples control by variac
- Solid-tap changer using anti-parallel SCRs
- Voltage regulation using servo system
- Phase controlled AC regulator
- Ferro-resonant AC regulator
- Switch mode AC regulator

#### 2.3.1. Solid-state tap changer and stepless control by variac

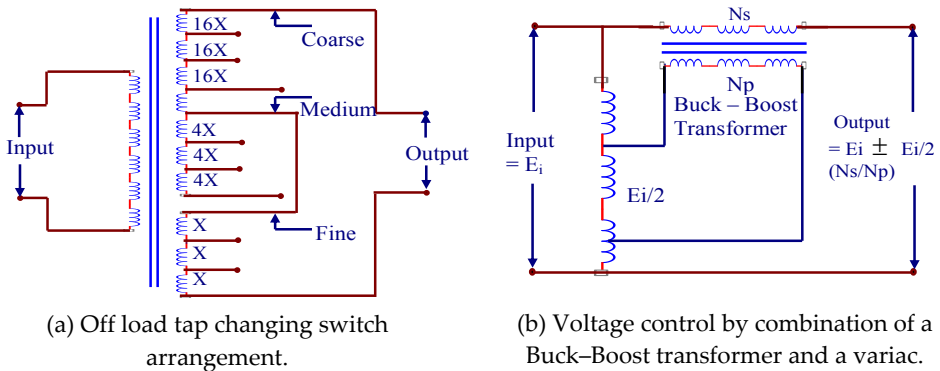
The voltage regulations by tap-changing switches are used in many industrial applications where the maintenance of output voltage at a constant value is not very stringent, such as ordinary battery chargers, electroplating rectifiers etc. For smaller installation, off-load tap

changing switches are used and for large installation on-load tap changing switches are used. The switches are generally incorporated at the secondary of the transformer. For a low voltage high current load, the switches are provided on the primary side of the transformer due to economical reason. For line voltage correction, taps are provided on the primary of the transformer. For three-phase transformers three pole tap changing switches are used.

In off-load tap changer, the output is momentarily cut-off from the supply. It is therefore used for low capacity equipment and where the momentary cut-off of the supply is not objectionable for the load. The major limitation of the off-load tap changing switches is the occurrences of arcs at the contact points during the change-over operation. This shortens the life of off-load rotary switches, particularly of high current ratings. In Fig. 5 (a), three four-position switches of an off load tap changer are shown, such that the minimum of X volts per step are available at the output.

The voltage is corrected by tap-charging switches in steps. Where stepless control is required, variable autotransformers or variacs are used. The normal variac consists of a toroidal coil wound on a laminated iron ring. The insulation of the wire is removed from one of the end faces and the wire is grounded to ensure a smooth path for the carbon brush. Carbon brush is used to limit the circulating current, which flows between the short-circuited turns.

A Buck-Boost transformer is sometimes used for AC voltage regulation when the output voltage is approximately the same as the mean input voltage as shown in Fig. 5(b). In this case if the output voltage is less than or greater than the desired value, it can be increased or decreased to the desired value by adding a suitable forward or reverse voltage with the input through the Buck-Boost transformer.



**Figure 5.** Circuit diagram of AC voltage controller using (a) Off load tap changer and (b) Buck-Boost transformer and variac.

2.3.2. Solid tap changer using anti-parallel SCRs

Anti-parallel SCRs combinations can replace the voltage sensitive relay in the tap-changing regulator. Figure 6 shows a tap changer with three taps which can be connected to the load

through three anti-parallel switches. When the SCR1-SCR2 switch is fired, tap 1 is connected to the load. Similarly taps 2 and 3 can be connected to the load through the SCR3-SCR4 and SCR5-SCR6 switches respectively. Thus, any number of taps can be connected to the load with similar SCR switches. When one group of SCRs operates for the whole cycle and other groups are off, the voltage corresponding to the tap of that group appears at the load. Changeover from one loop to the other is done simply by shifting the firing pulses from one group of SCRs to the other.

With resistive load, the load current becomes zero and the SCRs stop conduction as soon as the voltage reverses its polarity. Therefore, when one group is fired, the other groups are commutated automatically. With reactive loads, the situation is complicated by the fact that the zero current angle depends on the load power factor. This means that the SCR conducts a finite value of current at the time of reversal of line voltage. This results in either preventing a tap change due to reverse bias on the SCR to be triggered or causing a short circuit between the taps through two SCRs.

### 2.3.3. Voltage regulation using servo system

Voltage regulators using servo systems are quite common. Both single and three-phase types are available. The rating of this type of regulator is quite high and is more economical for high power rating. This regulator normally consist a variac driven by a servomotor, a sensing unit and a voltage and power amplifier to drive the motor in a reversible way. Various types of driving motor may be used for regulating the unit, such as direct current, induction and synchronous motors. However, in all cases, the motor must come to rest rapidly to avoid overrun and hunting. The amount of overrun may be reduced by dynamic braking in the case of a DC motor or by disconnecting the motor from the variac by a clutch as soon as the signal from the measuring unit ceases. The main disadvantage of this type of regulator is the low life of the contact points of the relays.

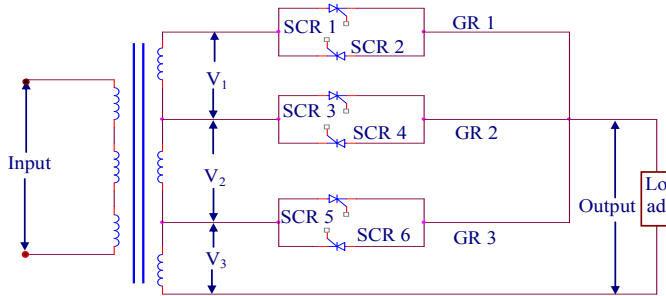
### 2.3.4. Phase controlled AC voltage regulator

Voltage regulators using SCRs are quit common. The load voltage is regulated by controlling the firing instants of the SCRs. There are various circuits for single phase and three phase regulators using SCRs. Though the output voltage can be precisely controlled by this method, the harmonic introduced in the load voltage are quit large and this circuit is used for applications where the output voltage waveform need not be strictly sinusoidal. The circuit arrangement for a single phase SCR regulator is shown in Fig. 6 and Fig. 7.

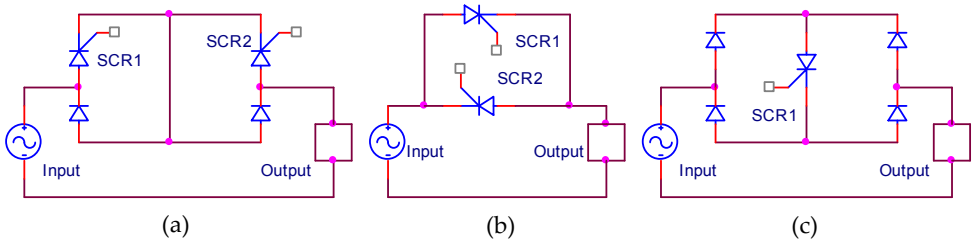
### 2.3.5. Ferro-resonant AC voltage regulator

The concept of the stabilization of AC voltage using a saturated transformer is rather old. The basic circuit arrangement consists of a linear reactor or transformer T1 and a nonlinear saturated reactor or transformer T2 connected in series as shown in Fig. 8. Since the two elements T1 and T2 are in series, the current through them is the same. Transformer T2 is operated under saturated. The voltage division between the two is according to their

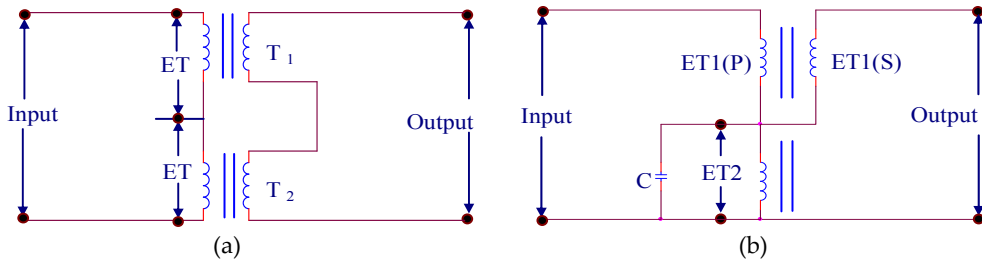
impedances. Due to nonlinear characteristics of T2 the percentage change of voltage across it is much smaller compared to the percentage change of input voltage. If a suitable voltage proportional to the current is subtracted from the voltage across T2 a practically constant output voltage can be obtained. The circuit arrangement shown in Fig. 8(a) has some drawbacks such as, no load input current is high, and good output voltage stability can be achieved only at a particular load. Hence some modifications are necessary to improve its performance. The major modification is to place a capacitor across the saturated transformer T2 that is shown in Fig. 8(b).



**Figure 6.** Circuit diagram of solid tap changer using anti-parallel SCRs.



**Figure 7.** Phase controlled AC voltage regulator, (a) Using back to back SCR and diode and (b) using inverse parallel SCR (c) Using diode-bridge and single SCR



**Figure 8.** Ferro-resonant AC voltage regulator.

The value of the capacitor is such that it resonant with the saturated inductance of T2 at some point. The characteristics of the circuit is such that a small change in voltage across T2



causes the circuit to go out of resonance consequently a large change in input current and power factor. For a change in the input voltage, the change in voltage across the resonant circuit is small but the change in voltage at T1 is large, and by suitable proportioning of the voltage, a good degree of stabilization is achieved for the variation of input voltage as well as load current. The simple Ferro-resonant regulator has the following disadvantages:

- a. The output voltage changes with frequency.
- b. Since the core operates in saturation and output is derived from the tank circuit, the core volume is large, the core losses are high and external magnetic field is also high.

### 2.3.6. *Switch mode AC voltage regulator*

In switch mode AC voltage regulator, the switching devices are continuously switching on and off with high frequency in order to transfer energy from input to output. The high operating frequency results in the smaller size of the switch mode power supplies since the size of power transformer inductors and filter capacitors is inversely proportional to the frequency. The SMPS are more complicated and more expensive, their switching current can cause noise problems, and simple designs can have a poor power factor.

Four common types of switch mode converters are used in DC-DC conversion. They are Buck, Boost, Buck-Boost and C<sup>^</sup>UK converters. Researches are trying to modify these DC regulators to regulate AC voltages. Buck- Boost and C<sup>^</sup>uk converter configuration has been investigated for voltage regulation [17-18]. But in every case it is found that the input power factor is very low and the efficiency is poor.

## 3. Design and analysis of switching-mode AC voltage regulator

### 3.1. Operation principle of switching-mode AC voltage regulator

#### 3.1.1. *Operation of power circuit*

Voltage sag is an important power quality problem, which may affect domestic, industrial and commercial customers. Voltage sags may either decrease or increase in the magnitude of system voltage due to faults or change in loads. Momentary and sustained over voltage and under voltage may cause the equipment to trip out, which is highly undesirable in certain application. In order to maintain the load voltage constant in case of any fluctuation of input voltage or variation of load some regulating device is necessary.

In this chapter the principle of operation of high frequency switching AC voltage regulator, design of its filter circuit and snubber circuit are described. Performance of the regulator is also analyzed using simulation software OrCAD version 9.1. Switch-mode power supplies (SMPS) incorporate power handling electronic components which are continuously switching on and off with high frequency in order to provide the transfer of electric energy from input to output. The design of AC voltage regulator depends on power requirement, degree of stability and efficiency. Solid state AC regulator using phase control technique are not new and are widely used in many application such as heating and lighting control etc.

These regulators are not suited for critical loads because the output waveforms are truncated sine waves, which contain large percentage of distortion. The input power factor is low. These drawbacks are largely overcome and the voltage can be efficiently controlled by means of a solid-state AC regulator using PWM technique.

The power circuit of the proposed AC voltage regulator is shown in Fig. 9. The circuit operation can be explained with the help of Fig. 10. During positive half cycle of the input voltage, at mode 1, when switch-1 is on and switch-2 is off, the current passes through diode D1, switch-1, diode D4 and through the inductor and the energy is stored in the inductor. At mode 2, when switch-1 is off and switch-2 is on, the energy stored in the inductor is transferred through diode D8, switch-2 and diode D5. At mode 1, power is transferred from source and at mode 2, power is not transferred from the source, so by controlling the on and off duration of switch-1 output power can be controlled.

During negative half cycle of the input voltage, at mode 1, when switch-1 is on and switch-2 is off the current passes through the inductor, diode D3, switch-1, and diode D2 and the energy is stored in the inductor. At mode 2, when switch-1 is off and switch-2 is on the energy stored in the inductor is transferred through diode D6, switch-2 and diode D7.

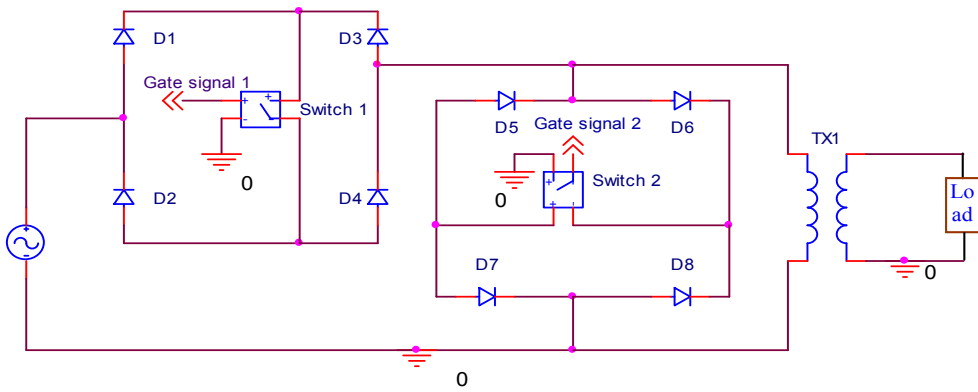


Figure 9. Power circuit of the proposed AC voltage regulator.

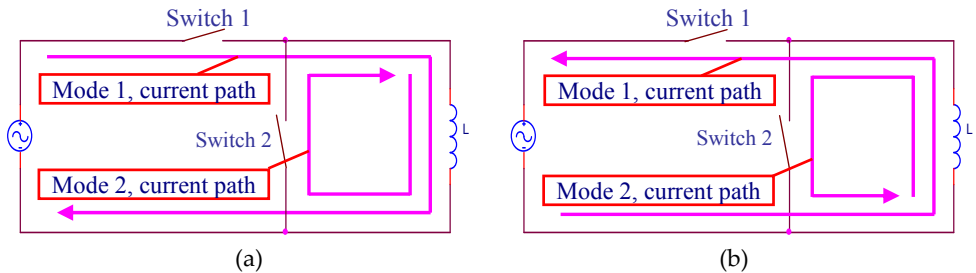
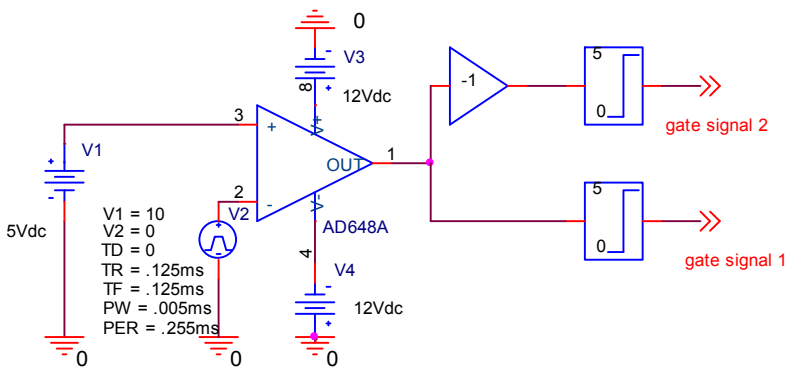


Figure 10. Operation of the power circuit of AC voltage regulator (a) Operation during positive half cycle (b) Operation during negative half cycle

### 3.1.2. Operation of control circuit

The gate signal generating circuit for a manually controlled AC voltage regulator is shown in Fig. 11. The control circuit incorporates an Operational Amplifier (OPAMP) whose positive input is a variable DC voltage V1, and negative input is a fixed saw-tooth signal V2. In this circuit the OPAMP acts as a comparator, output of the OPAMP depends on the difference of the two inputs. The negative input (saw-tooth wave) is kept constant and positive input (DC voltage) is varied. So output pulse width depends on DC input voltage of OPAMP i.e. when DC input is higher the output of comparator will be wider and when DC input is lower the output of comparator will be narrower.

The outputs of OPAMP are used to turn on/off the switches of the power circuit of the regulator to regulate the output voltage. The output of OPAMP is directly passed through limiter-1 which is the gate signal for switch-1 and after inverting the output of the comparator is passed through the limiter-2 which is the gate signal for switch-2. The function of the limiter is to limit the output of comparator from 0 to 5 V. When switch-1 of the power circuit is on then switch-2 should be off. So the gate signal generating circuit is arranged in such a way that when gate signal of switch-1 is on then gate signal for switch-2 is off and vice versa.



**Figure 11.** Gate signal generation circuit of manually controlled AC voltage regulator.

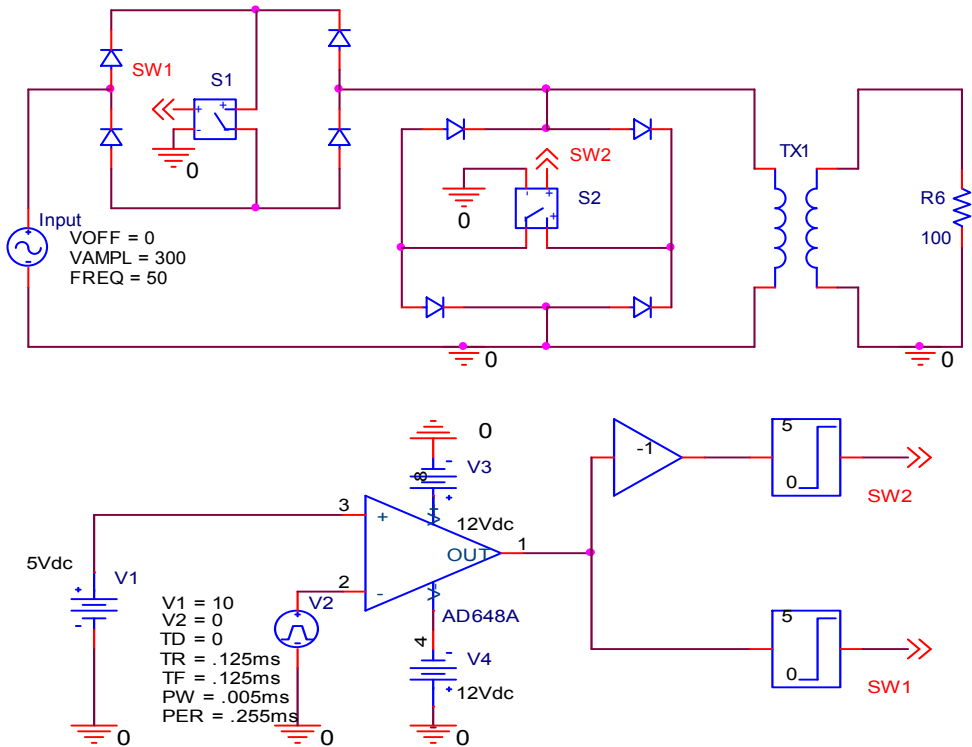
## 3.2. Manually controlled AC voltage regulator

When the stability is not very stringent, manually controlled AC voltage regulator is generally preferred from economic considerations.

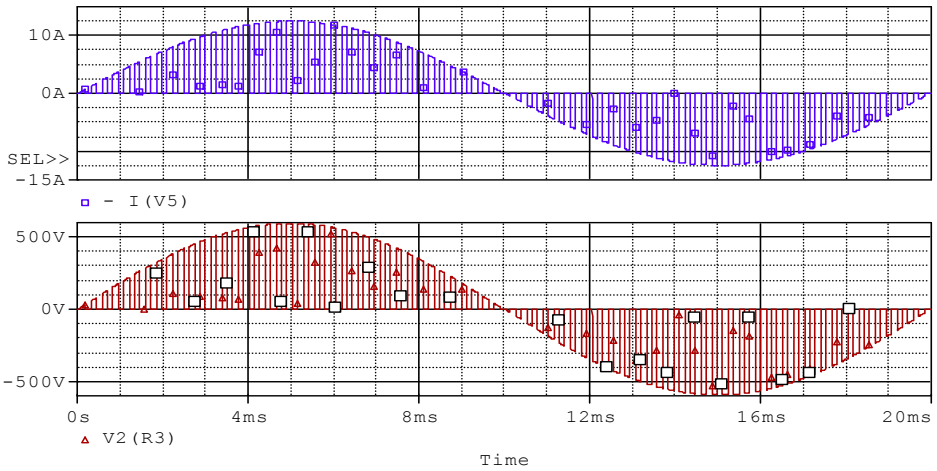
The basic circuit of a manually controlled AC voltage regulator is shown in Fig. 12. When any change in output voltage occurs due to change in input voltage or change in load, the voltage can be regulated to the desirable value by changing the DC voltage of the gate signal generating circuit manually. The power circuit of the proposed regulator shown in Fig. 12 is implemented using ideal switches; later part of this chapter the ideal switches is replaced by practical switches. The regulator proposed in this chapter is employed to regulate the output

voltage to 300V (peak) for variations of input voltage from 200V (peak) to 400V (peak), also for variation of load from 100 ohm to 200 ohm. However, the output voltage can be set to any desirable value according to requirement. The values of all voltages and currents indicated in this chapter are in peak values.

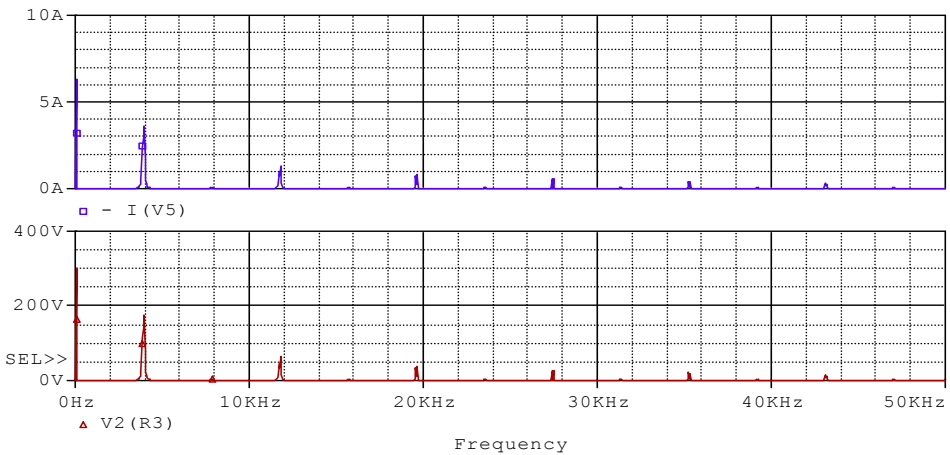
The input current and output voltage waveforms of the manually controlled AC voltage regulator as shown in Fig. 12, is shown in Fig. 13, when the input voltage is 300V and output voltage is also 300V. The spectrum of the input current and output voltage as shown in Fig. 13 is shown in Fig. From the waveforms it is seen that the waveforms are not smooth, sinusoidal and from the spectrum it is seen that due to high frequency switching the significant number and amount of harmonics occur. The switching frequency is selected to 4 KHz. Harmonics occurs at switching frequency and its odd multiple frequencies. So, filters are required at input and output side to filter out these harmonics to get desired sinusoidal waveforms.



**Figure 12.** Fundamental circuit of manually controlled AC voltage regulator (ideal switch implementation).



**Figure 13.** Input current and output voltage waveforms of the regulator shown in Fig. 12.  
 -I(V5): Input current, V(R3:2): Output voltage.



**Figure 14.** Spectrum of input current and output voltage waveforms. -I(V5): Input current V(R3:2): Output voltage.

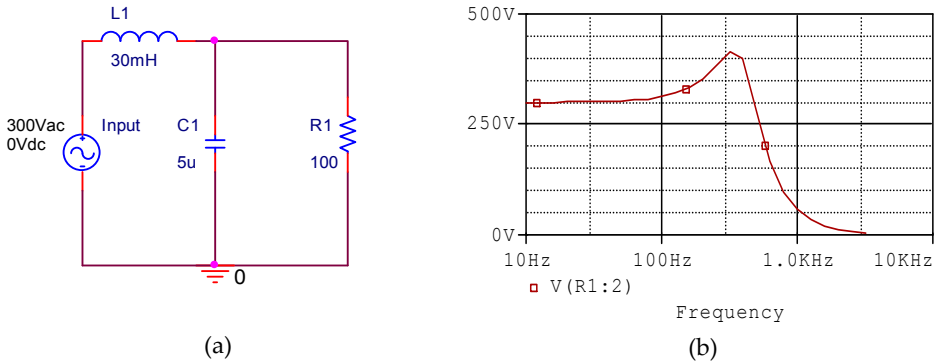
### 3.3. Filter design

#### 3.3.1. Output filter design

For getting smooth output voltage, a low pass LC filter of proper L and C value is needed at the output of this regulator. The output filter circuit and the corresponding AC sweep are shown in Fig. 15. From this circuit we can write,

$$V_0 = \frac{V_{in} \times J / \omega C}{J(\omega L - 1/\omega C)} \text{ or } \frac{V_0}{V_{in}} = \frac{1}{\omega C(\omega L - 1/\omega C)}$$

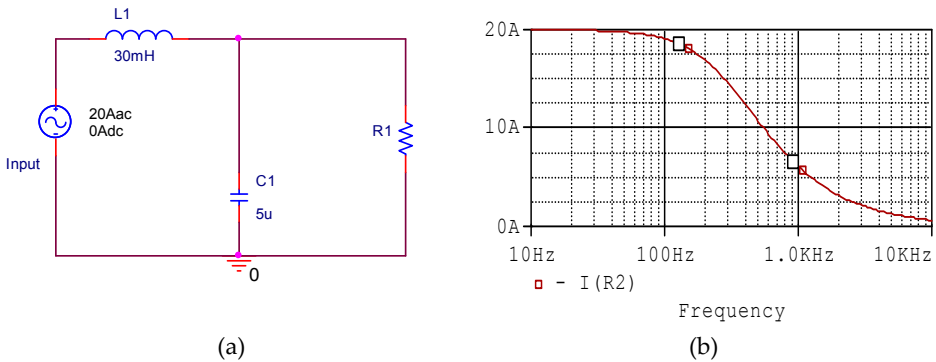
The input to the filter is high frequency modulated 50 Hz AC input. The switching signal that modulates the 50 Hz signal is taken to be 4 KHz in this case. So, we will have to make a filter that would pass signal up to 1 KHz (say) and attenuate all other frequencies. This would result a nearly sinusoidal output voltage. In the LC filter section we choose a capacitor of  $5\mu\text{F}$  and determine the value of inductor for a cutoff from AC sweep analysis through OrCAD simulation. We found the value of the inductor to be 30 mH.



**Figure 15.** Output voltage filter and AC sweep analysis (a) Output voltage filter (b) AC sweep analysis.

3.3.2. Input filter design

A low pass LC filter of proper L and C value is needed at the input of the regulator to filter out some of the harmonics from the supply system. The input filter circuit and the corresponding AC sweep are shown in Fig. 16. Input current contains harmonics at switching frequency 4 KHz and its odd multiple. In order to remove harmonics above 1 KHz, we choose a capacitor of  $5\mu\text{F}$  and determine the value of inductor for a cutoff from AC sweep analysis through OrCAD simulation. We found the value of the inductor to be 30 mH.



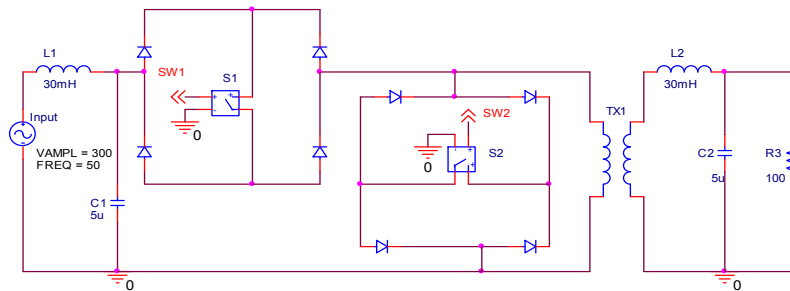
**Figure 16.** Input current filter and corresponding AC sweep analysis (a) Input current filter (b) AC sweep analysis.

### 3.4. Free wheeling path and surge voltage across switching devices

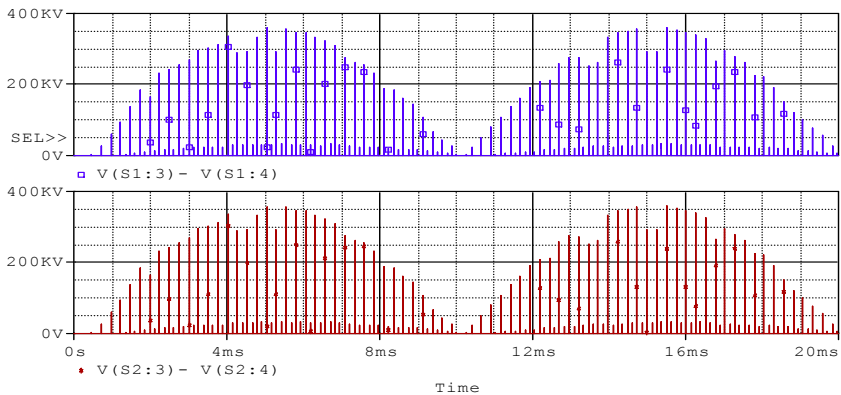
The power circuit of the proposed regulator with input and output filter is shown in Fig. 17. In an inductor, current does not change instantaneously. When the switches of power circuit switched on and off the current into the inductor of input and output filter are changed abruptly. Abrupt change of current causes a high  $di/dt$  resulting high voltage which is equal to  $Ldi/dt$ . These voltages appear across the switches as surge. Usually providing freewheeling path in restricts such occurrence.

#### 3.4.1. Surge voltage across switches

In the proposed circuit, two switches serve as the freewheeling path for each other. However, for very short period when one switch is turned off and other is turned on, an interval elapses due to delay in the switching time. As a result, freewheeling during this interval is disrupted in the proposed circuit. If the current in any inductive circuit is abruptly disrupted, a high  $Ldi/dt$  across the switch appears due to the absence of freewheeling path. High spiky surge voltage appears across the switches during these short intervals as shown in Fig. 18.



**Figure 17.** The power circuit of the proposed AC voltage regulator with input and output filters.

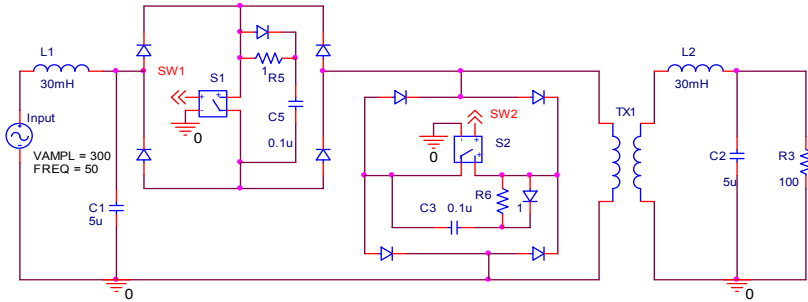


**Figure 18.** Voltage across switches with filters and without snubbers. V(S1:3)-V(S1:4): Voltage across switch-1, V(S2:3)-V(S2:4): Voltage across switch-2.

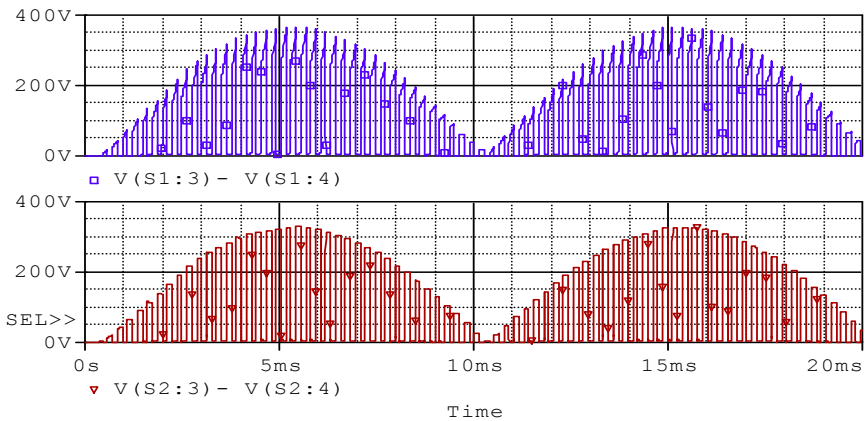
These spiky voltages across the switches may be excessively high, about thousand of kilovolt and which may destroy the switches during the operation of the circuit. Remedial measures should be taken to prevent this phenomenon to make the circuit commercially viable. In the proposed circuit RC snubbers are used for suppressing surge voltage across the switches. The power circuit of the proposed regulator with input output filter and snubbers is shown in Fig. 19.

Snubber enhances the performance of the switching circuits and results in higher reliability, higher efficiency, higher switching frequency, smaller size and lower EMI. The basic intent of a snubber is to absorb energy from the reactive elements in the circuit. The benefits of this may include circuit damping, controlling the rate of change of voltage or current or clamping voltage overshoot. The waveforms of voltages across switches with input output filters and snubbers are shown in Fig. 20.

Use of snubbers reduces the spiky voltage across the switches to a tolerate limit for practical application of the AC voltage regulator.



**Figure 19.** The power circuit of the proposed AC voltage regulator with input output filters and snubbers.



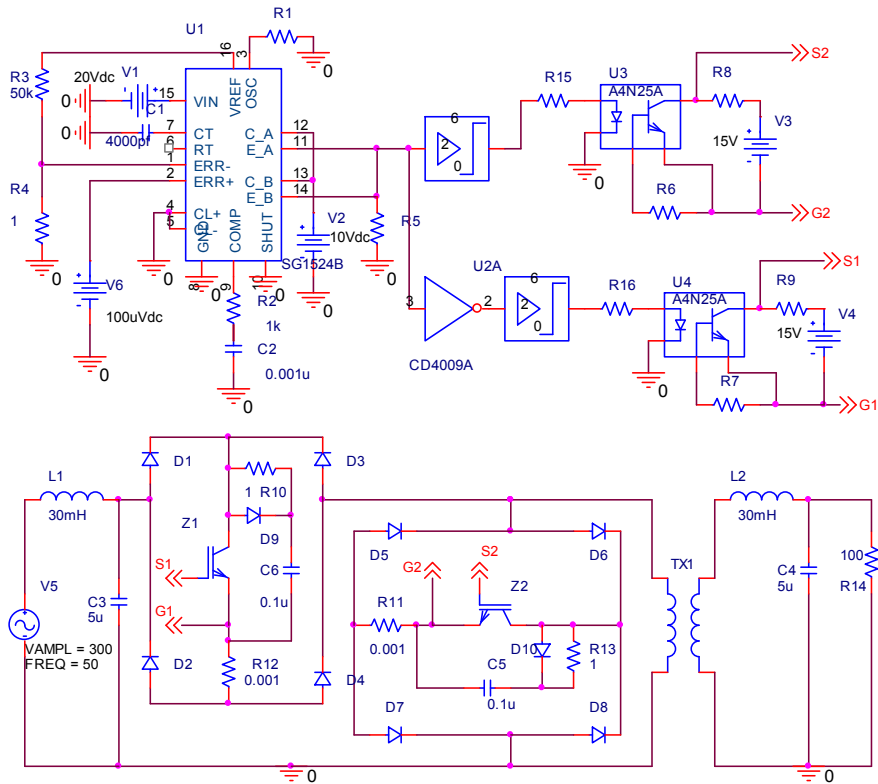
**Figure 20.** Voltage across switches with filters and snubbers. V(S1:3)-V(S1:4): Voltage across switch-1, V(S2:3)-V(S2:4): Voltage across switch-2.



### 3.5. Proposed AC voltage regulator with practical switches

In the previous section, we have studied the regulator using ideal S-break switches which have been operated by the pulses from the limiter. But for practical application, real switches are essential which are to be controlled by the pulses having ground isolation. The proposed AC voltage regulator circuit with practical switches is shown in Fig. 21. The ideal S-break switch is replaced by IGBT.

In the proposed regulator chip SG1524B is used to control the gate signal. Signal from the chip is fed to the Limiter and finally to the optocoupler. The output of the optocoupler is used to control the on off time of the IGBTs. The function of the Limiter is to limit the output voltage of the gate signal generating IC from 0 to 6 volts. Optocoupler is used to generate signaling voltage with ground isolation.



**Figure 21.** Manually controlled AC voltage regulator circuit with practical switches.

#### 3.5.1. Chip SG1524B for generation of gate signal

The Block diagram of the internal circuitry of the chip SG1524B is shown in Fig. 22. By controlling the error signals of the error amplifier the duty cycle of the gate signal to the

regulator can be controlled. Thus it is a very suitable device for using in the regulator circuits.

3.5.2. Results of proposed AC voltage regulator (practical switch implementation)

The waveforms of the input and output voltages of the proposed regulator are shown in Fig. 23 and Fig. 24. Fig. 23 shows the input and output voltages waveform when the input voltage is 200V and output voltage is 300V. Fig. 24 shows the input and output voltages waveform when the input voltage is 400V and output voltage is 300V. Fig. 25 and Fig. 26 show the input and output current waveforms corresponding to Fig. 23 and Fig. 24.

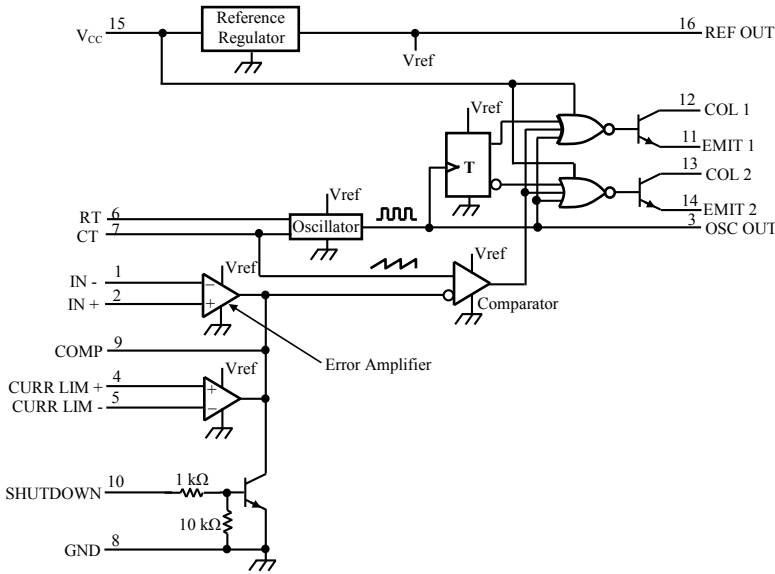


Figure 22. Block diagram of IC chip SG1524B

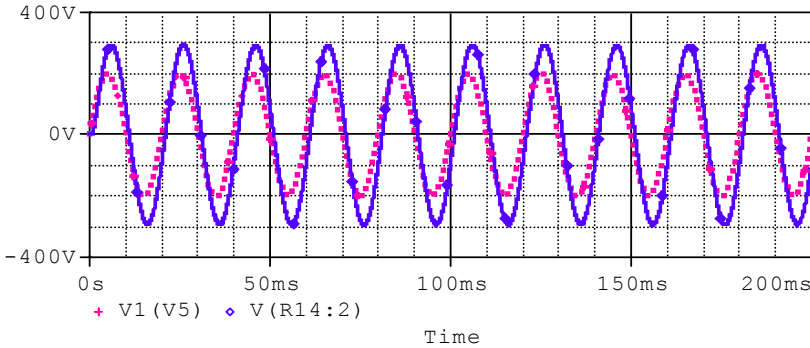
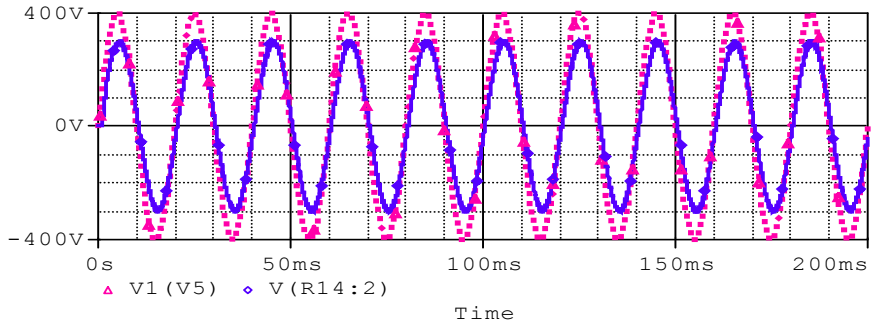
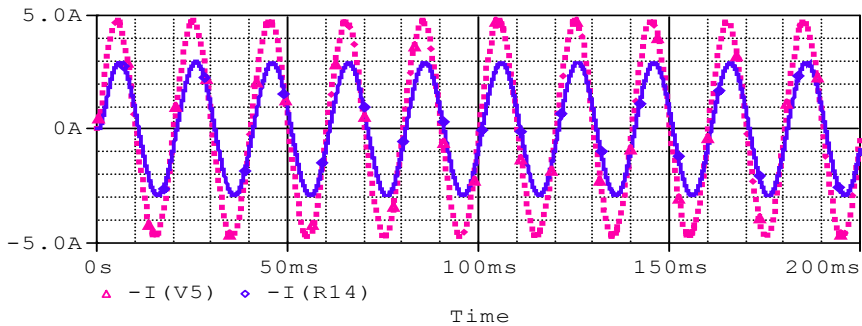


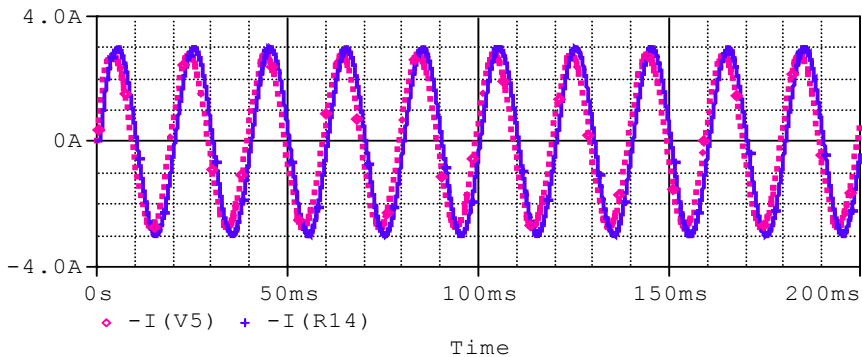
Figure 23. Input and output voltage waveforms, Input 200V output 300V. V1(V5): Input voltage – dotted line, V(R14:2): Output voltage – solid line.



**Figure 24.** Input and output voltage waveforms, Input 400V output 300V.  $V1(V5)$ : Input voltage – dotted line,  $V(R14:2)$ : Output voltage – solid line.

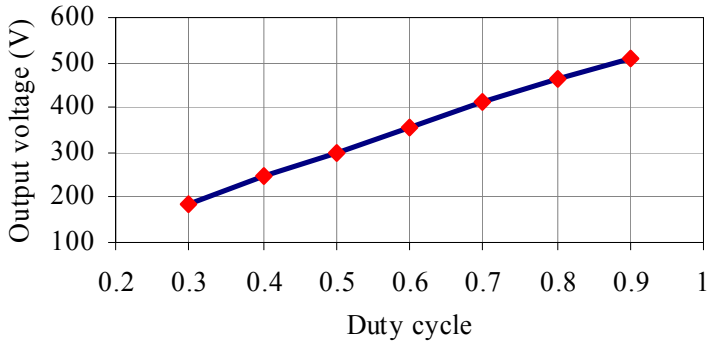


**Figure 25.** Input and output current waveforms for input 200V output 300V.  $-I(V5)$ : Input current – dotted line,  $-I(R14)$ : Output current – solid line.

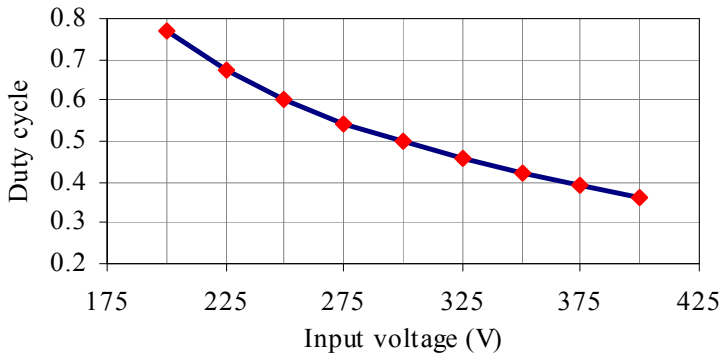


**Figure 26.** Input and output current waveforms for input 400V output 300V.  $-I(V5)$ : Input current – dotted line,  $-I(R14)$ : Output current – solid line.

From the waveforms shown in Fig. 23 to Fig. 26, it is seen that the waveforms of output voltage and input current is perfectly sinusoidal. The variation of output voltage of the proposed regulator with the duty cycle is shown in Fig. 27. The value of input voltage is kept constant to 300V. From Fig. 23 it is seen that the variation of output voltage with duty cycle is almost linear. The variation of duty cycle with the variation of input voltage from 200V to 400V to maintain the output voltage constant to 300V is shown in Fig. 28.



**Figure 27.** Variation of output voltage with duty cycle. Input voltage is 300V.



**Figure 28.** Variation of duty cycle with input voltage to maintain output voltage constant to 300V.

#### 4. Automatic controlled AC voltage regulator

In manually controlled AC voltage regulator control, the output voltage is sensed with a voltmeter connected at the output; the decision and correcting operation is made by a human judgment. The manual control may not be feasible always due to various factors. In automatic voltage regulators, all functions are performed by instruction, and give much better performance, so far as stability, speed of correction, consistency, fatigue, etc. are concerned.

There are two types of automatic control voltage regulator, discontinuous control and continuous control. The automatic control system consists of a sensing or measuring unit and a power control or regulating unit. The sensing unit compares the output voltage or the controlled variable with a steady reference and gives an output proportional to their difference called the error signal. The error voltage is amplified, integrated or differentiated or modified whenever necessary. The processed error voltage is fed to the main control unit to have required corrective action.

In the discontinuous type of control, the measuring unit is such as to produce no signal as long as the voltage is within certain limits. When the voltage goes outside this limit, a signal is produced by the measuring unit until the voltage is again brought within this limit. In this type of measuring or sensing unit, the correcting voltage is independent of percentage of error. When the voltage is brought back to this limit, the signal from the measuring unit is zero and the regulating unit remains at its new position until another signal is received from the measuring unit.

In continuous control, the measuring unit produces a signal with amplitude proportional to the difference between the fixed reference and the controlled voltage. The output of the measuring unit is zero when the controlled voltage or a fraction of it is equal to the reference voltage. The regulating or the controlling unit, which is associated with the continuous measuring unit, gives a correcting voltage proportional to the output of the measuring unit. The principle of operation of a continuous control AC voltage regulator is described in this section.

#### **4.1. Control and gate signal generating circuit for controlled AC voltage regulator**

Figure 29 shows the circuit of the proposed automatic controlled AC voltage regulator including the control and gate signal generating circuit. A fraction of the output voltage after capacitor voltage dividing and rectifying is passed through an OPAMP buffer. Buffer is used to remove the loading effect. Output voltage of the buffer is same as its input voltage. The output voltage of the buffer is further reduces using resistive voltage divider and taken as the negative input of the error amplifier of the PWM voltage regulating IC SG1524B.

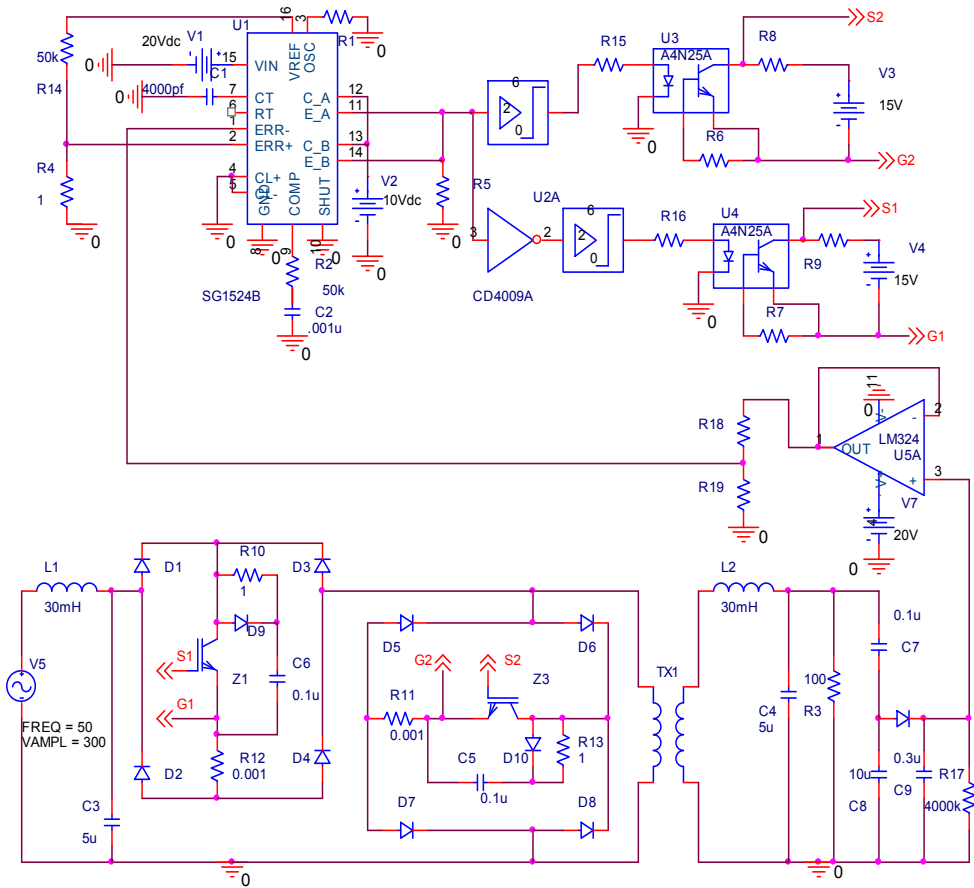
The positive input of the error amplifier is taken from the reference voltage of the chip, after voltage dividing using 50K and 1 ohm resistance. The positive input of the error amplifier is fixed and the negative input is error signal which will vary according to the output voltage. Since the error signal is applied to the negative input of the error amplifier, the duty cycle will be increased if the error signal is decreased and vice versa.

When the output voltage increases above the set value which is 300V either due to change in input voltage or load, the error signal will be increased, therefore the duty cycle will decrease. As a result less power will be transferred from the input to output, and output voltage start to decrease until it reaches to the set value.

When the output voltage decreases below the set value either due to change in input voltage or load then error signal will be decreased which will increase the duty cycle. As a result,

more power will be transferred from the input to output, and output voltage start to increase until it reaches to the set value.

When the output voltage is same as the set value than the negative and positive input of the error amplifier will be same as a result the duty cycle will remain same and output voltage will remain unchanged. In this way the proposed regulator will maintain output voltage constant, irrespective of the variation of input voltage and load.

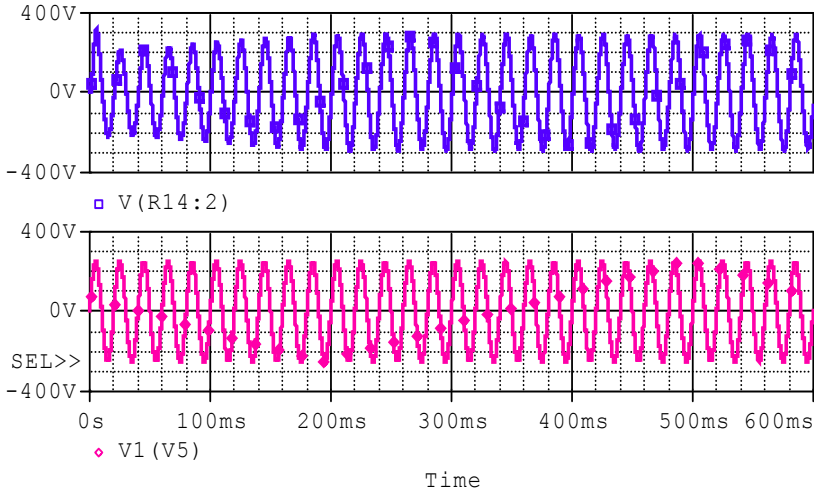


**Figure 29.** Automatic controlled AC voltage regulator circuit with practical switches.

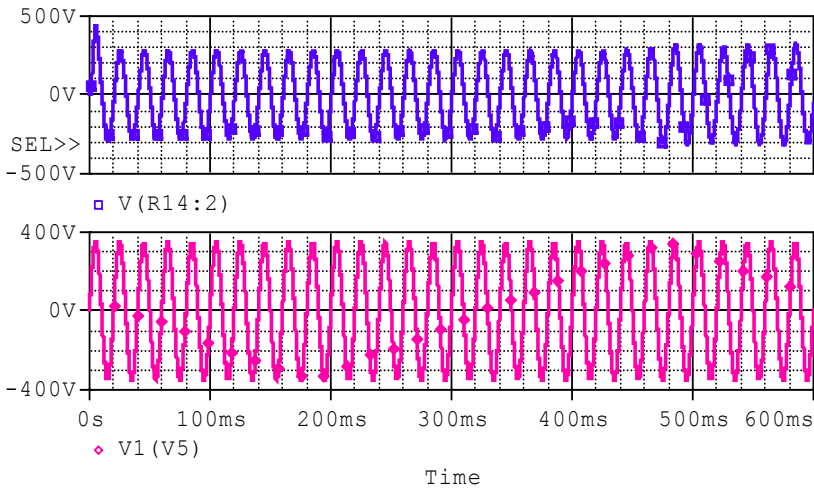
**4.2. Results of automatic controlled AC voltage regulator**

Figure 30 shows the input and output voltage waveforms of the proposed automatic controlled AC voltage regulator when the input voltage is 250V and output voltage is 300V. Figure 31 shows the input and output voltage waveforms of the proposed regulator when the input voltage is 350V and output voltage is 300V. Figure 32 and Fig. 33 shows the

waveforms of the input current and output currents corresponding to the waveforms of Fig. 30 and Fig. 31 for a load of 100 Ω.



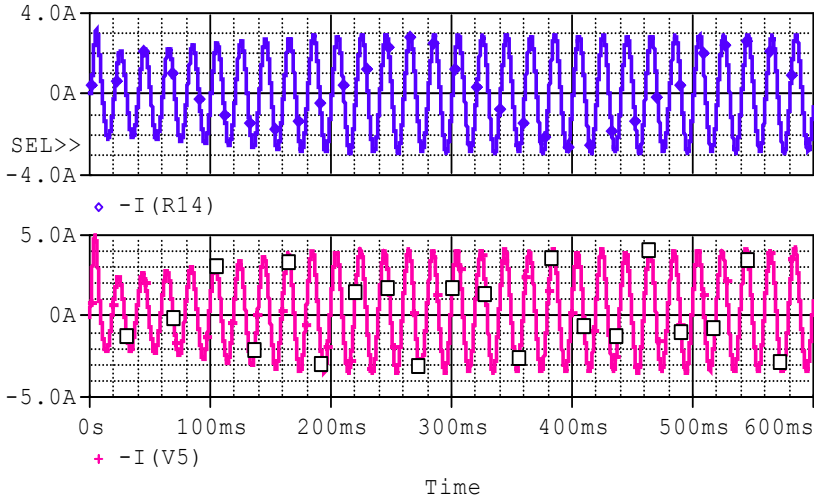
**Figure 30.** Input and output voltage waveforms for input 250V and output 300V. V1(V5): Input voltage-bottom figure, V(R14:2): Output voltage – top figure.



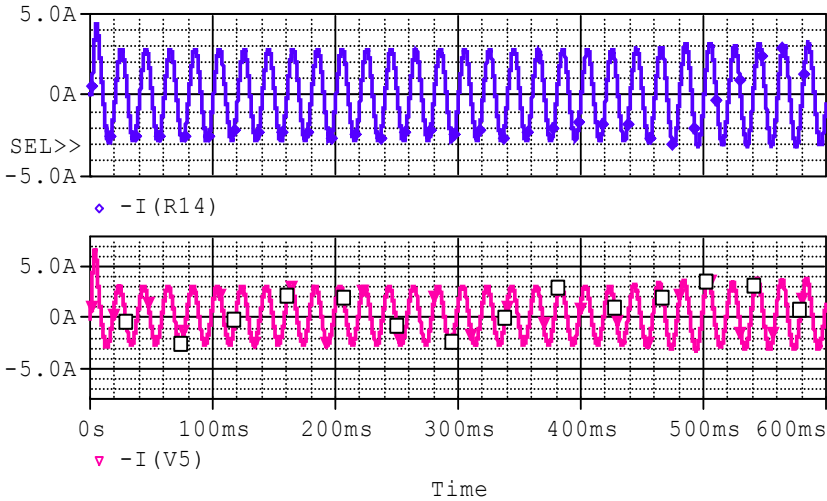
**Figure 31.** Input and output voltage waveforms for input 350V and output 300V. V1(V5): Input voltage-bottom figure, V(R14:2): Output voltage – top figure.

Table 1 summarizes the result of the proposed regulator to regulate output voltage to 300V for variation of input voltage from 200V to 350V and load from 100 ohm to 200 ohm. In this

table input current, output current, input power factor, and efficiency of the regulator are also provided. The proposed regulator can regulate the output voltage effectively, for a wide variation of input voltage and load with efficiency of more than 90% and input power factor more than 0.9.



**Figure 32.** Input and output current waveforms for input 250V output 300V.  $-I(V5)$ : Input current – bottom figure,  $-I(R14)$ : Output current – top figure.



**Figure 33.** Input and output current waveforms for input 350V output 300V.  $-I(V5)$ : Input current – bottom figure,  $-I(R14)$ : Output current – top figure.



$V_{in}$ (V)	$I_{in}$ (A)	Input pf	$P_{in}$ (W)	$V_{out}$ (V)	Load ( $\Omega$ )	$I_{out}$ (A)	$P_{out}$ (W)	Efficiency (%)
200	4.81	1.00	481	295	100	2.95	435.13	90.46
225	4.30	1.00	483.09	298	100	2.98	444.02	91.91
250	3.92	1.00	489.70	300	100	3.00	450.00	91.89
275	3.60	1.00	495.00	300	100	3.00	450.00	90.91
300	3.30	1.00	493.79	300	100	3.00	450.00	91.13
325	3.10	0.99	498.85	302	100	3.02	456.02	91.41
350	2.95	0.98	508.41	305	100	3.05	465.13	91.49
250	2.07	0.96	248.73	300	200	1.50	225.00	90.46
275	1.90	0.95	248.46	300	200	1.50	225.00	90.56
300	1.75	0.95	248.20	300	200	1.50	225.00	90.65
325	1.68	0.93	253.12	302	200	1.51	228.01	90.08
350	1.60	0.91	253.77	305	200	1.53	232.56	91.64

\*All voltages and currents values in this table are in peak values.

**Table 1.** Results of proposed automatic controlled AC voltage regulator for maintaining output 300 V.

## 5. Conclusion

An essential feature of efficient electronic power processing is the use of semiconductor devices in switch mode to control the transfer of energy from source to load through the use of pulse width modulation techniques. Inductive and capacitive energy storage elements are used to smooth the flow of energy while keeping losses at a lower level. As the frequency of the switching increases, the size of the capacitive and inductive elements decreases in a direct proportion. Because of the superior performance, the SMPS are replacing conventional linear power supplies.

In this chapter the design and analysis of an AC voltage regulator operated in switch mode is described in details. AC voltage regulator is used to maintain output voltage constant either for an input voltage variation or load variation to improve the power quality. If the output voltage remains constant, equipment life time increases and outages and maintenance are reduced.

At first the regulator is analyzed using ideal switches, then the ideal switches is replaced by practical switches which required isolated gate signal. The procedure of smoothing the input current and output voltage, and suppressing the surge voltage across the switches is described. A manually controlled AC voltage regulator is analyzed then the concept of operation of an automatic controlled AC voltage regulator is described. Finally an automatic controlled AC voltage regulator is designed and its performance is analyzed.

The proposed regulator can maintain the output voltage constant to 300V, when input voltage is vary from 200V to 350V also for variation of load. To maintain constant output voltage PWM control is used. By varying the duty cycle of the control circuit have achieved the goal of maintaining the constant output voltage across load. For generation of gate

signal of the switches an IC chip SG1524B is used which is compact and commercially available at a very low cost. The input current of the proposed regulator is sinusoidal and the input power factor is above 0.9. From simulation results it is seen that the efficiency of the proposed regulator is more than 90%.

## Author details

Raju Ahmed

*Electrical and Electronic Engineering Department, Dhaka University of Engineering and Technology (DUET), Gazipur, Bangladesh*

Mohammad Jahangir Alam

*Electrical and Electronic Engineering Department, Bangladesh University of Engineering and Technology (BUET), Dhaka, Bangladesh*

## 6. References

- [1] P. B. Steciuk and J. R. Redmon, "Voltage sag analysis peaks customer service," *IEEE Comput. Appl. Power*, vol. 9, pp. 48-51, Oct. 1996.
- [2] M. F. McGranaghan, D. R. Mueller, and M. J. Samotyj, "Voltage sags in industrial systems," *IEEE Transactions on Industrial Application.*, vol. 29, pp. 397-403, Mar./Apr. 1993.
- [3] M. H. J. Bollen, "The influence of motor reacceleration on voltage sags," *IEEE Transactions on Industrial Application*, vol. 31, pp. 667-674, July/Aug. 1995.
- [4] M. H. J. Bollen, "Characterization of voltage sags experienced by three phase adjustable-speed drives," *IEEE Transactions on Power Delivery*, vol. 12, pp. 1666-1671, Oct. 1997.
- [5] H. G. Sarmiento and E. Estrada, "A voltage sag study in an industry with adjustable speed drives", *IEEE Industry Applications Magazine.*, vol. 2, pp. 16-19, Jan./Feb. 1996.
- [6] N. Kutkut, R. Schneider, T. Grand, and D. Divan, "AC voltage regulation technologies," *Power Quality Assurance*, pp. 92-97, July/Aug. 1997.
- [7] D. Divan, P. Sulherland, and T. Grant, "Dynamic sag corrector: A new concept in power conditioning," *Power Quality Assurance*, pp.42-48, Sept./Oct. 1998.
- [8] A. Elnadt and Magdy M. A. Salama, "Unified approach for mitigating voltage sag and voltage flicker using the DSTATCOM," *IEEE Transactions on Power Delivery*, vol. 30, no. 2, April 2005.
- [9] S. M. Hietpas and R. Pecan, "Simulation of a three-phase boost converter to compensate for voltage sags, " in *Proceeding. IEEE 1998 Rural Electric Power Conference*, pp. B4-1-B4-7, Apr. 1998.
- [10] S. M. Hietpas and Mark Naden, "Automatic voltage regulator using an AC voltage-voltage converter," *IEEE Transactions on Industrial Application*, vol. 36, pp. 33-38, Jan.\Feb. 2000.
- [11] F. Z. Peng, Lihue Chen, and Fan Zhang, "Simple topologies of PWM AC-AC converters," *IEEE Power Electronics Letters*, vol. 1, no.1, March 2003.

- [12] G. Venkataramanan, B. K. Johnson, and A. Sundaram, "An AC-AC power converter for custom power applications," *IEEE Transactions on Power Delivery*, vol. 11, pp. 1666-1671, July 1996.
- [13] V. Nazquez, A. Velazquez, C. Hernandez, E. Rodríguez and R. Orosco, "A Fast AC Voltage Regulator," *CIEP 2008. 11<sup>th</sup> IEEE International Power Electronics Congress*, pp. 162-166, Aug. 2008.
- [14] J. Nan, T. Hou-jun, L. Wei and Y. Peng-sheng, "Analysis and control of Buck-Boost Chopper type AC voltage regulator," *IPEC'09. IEEE 6<sup>th</sup> International Power Electronics and Motion Control Conference*, pp. 1019-1023, May 2009.
- [15] N. A. Ahmed, M. Miyatake, H. W. Lee and M. Nakaoka, "A Novel Circuit Topology of Three-Phase Direct AC-AC PWM Voltage Regulator" *Industry Applications Conference, 2006. 41<sup>st</sup> IAS Annual Meeting. Conference Record of the 2006 IEEE*, pp. 2076-2081, Oct. 2006.
- [16] V. Nazquez, A. Velazquez and C. Hernandez, "AC Voltage Regulator Based on the AC-AC Buck-Boost Converter," *ISIE 2007. IEEE International Symposium on Industrial Electronics*, pp. 533-537, Jun. 2007.
- [17] P. K. Banerjee, "Power line voltage regulation by PWM AC Buck-Boost voltage controller," A M.Sc. thesis, Department of EEE, BUET, July, 2002.
- [18] A. Hossain, "AC voltage regulation by Cúk switch mode power supply," A M.Sc. thesis, Department of EEE, BUET, July, 2003.
- [19] Li B. H., Choi S.S., Vilathgamuwa D. M., Design considerations on the line-side filter used in the dynamic voltage restorer, *IEE Proceedings - Generation, Transmission, and Distribution*, pp. 1-7, 2001.
- [20] Wang Jing, Xu Aiqin, Shen Yueyue., A Survey on Control Strategies of Dynamic Voltage Restorer, *13th International Conference on Harmonics and Quality of Power (ICHQP)*, pp. 1-5, Sept. 28 2008-Oct. 1, 2008,.
- [21] Nielsen J.G., Blaabjerg F., A Detailed Comparison of System Topologies for Dynamic Voltage Restorers, *IEEE Transactions on Industry Applications*, vol, 41, no. 5, pp. 1272-1280, 2005.
- [22] OrCAD Software, Release 9: 1985-1999 OrCAD, Inc., U.S.A.
- [23] Slobodan Cúk, "Basics of Switched Mode Power Conversion Topologies, Magnetics, and Control," *Modern Power Electronics: Evaluation, Technology, and applications*, Edited by B.K. Bose, IEEE Press, pp. 265-296, 1992.
- [24] M. H. Rashid, "Power Electronics – Circuits, Devices, and Applications," *Prentice Hall India*, Second Edition, 2000, pp.317-387.
- [25] P.C. Sen, "Power Electronics," *Tata McGraw-Hill Publishing Company Ltd., India*, 1987, pp. 588-614.
- [26] R. Thompson, "A Thyristor Alternating Voltage Regulator," *IEEE Trans. on Ind. and Gen. Application*, vol. IGA 4 (1968) 2, pp. 162-166., 1968.
- [27] E. J. Cham and W. R. Roberts, "Current Regulators for Large Rectifier Power Supplies Used on Electrochemical Processing Lines," *IEEE Trans. on Ind. and Gen. Application IGA-4 (1968) 6*, pp. 609-618.
- [28] J. M.(Jr), Mealing , "A Coherent Approach to the Design of Switching Mode DC Regulators," *IEEE Conf. Rec. IGA*, pp.177-185, Oct. 1967.

- [29] Unitrode, "Switching Regulated Power Supply Design Seminar Manual," Unitrode Corporation, U. S. A, 1986.
- [30] M. H. Rashid, "A Thyristor Chopper With Minimum Limits on Voltage Control of DC Drives," *International Journal of Electronics*, Vol. 53, No. 1, pp.71-81, 1982.
- [31] K. P. Severns and G. E. Bloom, "Modern DC-to-DC Switch Mode Power Converter Circuits," Van Nostrand Reinhold Company, Inc., New York, U. S. A, 1983.
- [32] S. Cúk, "Survey of Switched Mode Power Supplies," *IEEE International Conference on Power Electronics and Variable Speed Drives*, London, pp. 83-94, 1985.
- [33] M. Ehsani, R. L. Kustom, and R. E. Fuja, "Microprocessor Control of A Current Source DC-DC Converter," *IEEE Transactions on Industrial Applications*, Vol. IA19, No. 5, pp. 690-698, 1983.
- [34] R. D. Middlebrook, "A Continuous Model for the Tapped-Inductor Boost Converter," *IEEE Power Electronics Specialists Conference Record*, Culver City, CA, U. S. A, pp.63-79, 1975.
- [35] Slobodan Cúk R. D. Middlebrook, "A General Unified Approach to Modeling Switching DC-to-DC Converters in Discontinuous Conduction Mode," *IEEE Power Electronics Specialists Conference Record*, Palo Alto, CA, U. S. A, pp. 36-57, 1977.
- [36] R. D. Middlebrook and Slobodan Cúk, "Modeling and Analysis Methods for DC-to-DC Switching Converters," *IEEE International Semiconductor Power Converter Conference Record*, Lake Buena Vista, FL, U. S. A, pp.90-111, 1977.
- [37] Slobodan Cúk and R. D. Middlebrook, "Coupled Inductor and other Extensions of a New Optimum Topology Switching DC-to-DC Converter," *IEEE Industry Applications Society Annual Meeting, Record*, Los Angeles, CA, U. S. A, pp.1110-1126, 1977.
- [38] R. D. Middlebrook and Slobodan Cúk, "Isolation and Multiple Output Extensions of a New Optimum Topology Switching DC-to-DC Converter," *IEEE Power Electronics Specialists Conference Record*, Syracuse, NY, U. S. A, pp.256-264, 1978.
- [39] C. Chen and Deepakraj M. Divan, "Simple Topologies for Single Phase AC Line Conditioning," *IEEE Transactions on Industry Applications*, Vol.30, No.2, pp. 406-412, March/April 1994.
- [40] Mark F. McGranaghan, David R. Mueller and Marek J. Samotyj, "Voltage Sags in Industrial Systems," *IEEE Transactions on Industry Applications*, Vol.29, No.2, pp. 397-403, March/April 1993.
- [41] S. Cúk and R. D. Middlebrook, "Advances in Switched Mode Power Conversion," *IEEE Transactions on Industrial Electronics*, Vol. IE 30. No. 1, pp.10-29, 1983.
- [42] N. Mohan, Tore M. Undeland and William P. Robbins, "Power Electronics- Converters, Applications, and Design," John Wiley and Sons Inc., Second ed., pp. 161-195 & 669-695, 1995
- [43] H. Veffer, "High Current, Low Inductance GTO and IGBT Snubber Capacitors," *Siemens Components*, June, pp. 81-85, 1990.
- [44] B. D. Bedford and R. G. Hoft, "Principles of Inverter Circuits," Wiley: 1964.
- [45] E. R. Hnatek, "Design of Solid-State Power Supplies," Van Nostrand Reinhold; 1971.
- [46] A. I. Pressman, "Switching and Linear Power Supply," *Power Converter Design*, vol. I and vol. II, Hayden; 1977.