

Pre-distortion Linearization for 64-QAM Modulation in Ka-Band Satellite Link

P. Sojoodi Sardrood,[†], G.R. solat and P. Parvand

Iran Telecommunication Research Centre

Summary

In this paper the efficiency of linearization for pre-distortion in 64-QAM modulation, utilized in Ka-band satellite link for DVB-RCS services, is investigated. The linearization is simulated by Matlab-Simulink, for a GEO Satellite and DVB-RCS service. A TWTA power amplifier with 1dB back-off is used in this satellite link, and to conclude the results, the spectrum and eye-diagram in both transmitter and receiver side are evaluated.

Key words:

Pre-distortion, Modulation, Power Amplifier, TWTA

1. Introduction

The new generation of satellite receivers for DVB-RCS services in Ka-band are utilizing higher order modulation such as 64-QAM and higher efficiency TWTA power amplifiers.

One of the most expensive parts of satellite communication systems is the output power amplifier, which has the most power consumption. There is a trade off between working in the linear area and the maximum efficiency. Linearization techniques increase the efficiency by keeping the linearity of power amplifiers. To have enough linearity the amplifier should function at low output level. Distance between operation point and saturation point is so called Back-Off. Linearization reduces the Back-Off. Table. 1.

Shows the amount of improvement for a multi carrier system using predistortion [1].

Table 1: Linearization Benefits

Pre-distortion	No	Yes
TX Power	10W	10W
PAR	9dB	9dB
Backoff	12dB	9dB
PA Power Rating	160W	80W
Efficiency	9%	18%
Power Dissipation	101W	45W

2. Power Amplifier

Before applying linearization techniques, studying of non-linearity characteristics of power amplifiers is important. To evaluate non-linearity effects in high power amplifiers, a polynomial is utilized to justify output to input transfer function [2]. The output of the system can be expressed by a 3rd order polynomial, shown by Eq.1

$$y = a_1 \cdot x + a_2 \cdot x^2 + a_3 \cdot x^3 \quad (1)$$

In the Eq.1, a_1 is the linear gain of the amplifier, and a_2 and a_3 are the non-linear gains respectively. The block diagram of a power amplifier is illustrated in Fig. 1, where $v_i(t)$ and $v_o(t)$ are input and output signals of systems respectively. To show the non-linearity affect of the amplifier, the system is tested with two tones, with different frequencies, the output signal and then the non-linearity affect due to TWTA power amplifier is evaluated. But applying two tones in Eq. 2 into the polynomial in Eq.1, the output of high power amplifier and the out spectral effects is clarified.

$$v_i(t) = A \cos(\omega_1 t) + A \cos(\omega_2 t) \quad (2)$$

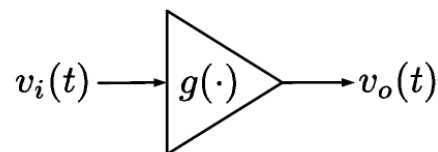

Fig.1. Block diagram of input and output of power amplifier

The result of spectral expansion for the output spectrum, when two tones are applied to the input, is illustrated in Fig. 2, and certainly all coefficients in Eq. 1 are real. Generally the output of the system can be expressed by Eq.3.

$$v_o(t) = a_1 v_i(t) + a_2 v_i(t)^2 + a_3 v_i(t)^3 \quad (3)$$

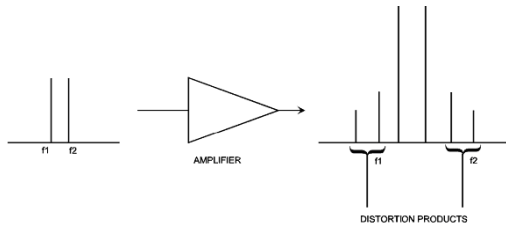

Fig.2. spectral expansion for the output spectrum, when two tones are applied to the input.

Ordinarily, the function of a power amplifier is described by AM-AM and AM-PM characteristics. The AM-AM characteristic can be extracted from the non-linear polynomial, stated in Eq.3, although AM-PM characteristic can not be extracted. But the AM-PM characteristic can be extracted by Eq. 5. The AM-AM and AM-PM characteristics of the power amplifier are shown by g_a and g_ϕ , respectively [2].

$$v_o(t) = g(|v_i(t)|^2)v_i(t) = g_a(|v_i(t)|^2)e^{j\phi_a(|v_i(t)|^2)}v_i(t) \quad (4)$$

$$g_a(|v_i(t)|^2) = a_1 + a_3|v_i(t)|^2 + a_5|v_i(t)|^4$$

$$g_\phi(|v_i(t)|^2) = \phi_1 + \phi_3|v_i(t)|^2 + \phi_5|v_i(t)|^4$$

In the TWTA high power amplifier with Saleh modeling, the AM-AM and AM-PM characteristic are introduced by Eq.5 and Eq.6.

$$A(r) = \frac{\alpha_a r}{1 + \beta_a r^2} \quad (5)$$

$$P(r) = \frac{\pi}{3} \frac{\alpha_p r}{1 + \beta_p r^2} \quad (6)$$

$$\alpha_a = 1.9638, \beta_a = .9945$$

$$\alpha_p = 2.5293, \beta_p = 2.8168$$

The non-linear characteristics are drawn in Fig. 3 verses input voltage.

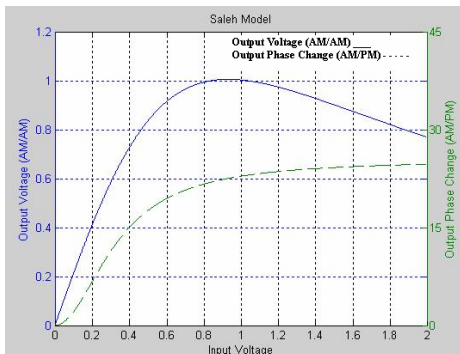

Fig.3. The non-linear characteristics of TWTA with saleh model.

Fig.4 illustrates the result of test with two tone inputs, and obviously the affect of non-linearity of the amplifier is observed in the output spectrum.

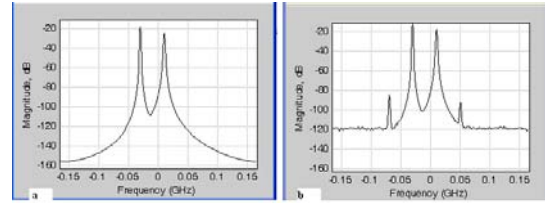

Fig.4. (a) input of TWTA amplifier (b) output of TWTA amplifier.

3. Baseband Pre-distortion

Mathematically, a pre-distortion system has an inverse function of the high power amplifier [3-11]. Pre-distortion system and the high power amplifier are cascaded together as a chain, and it is illustrated in Fig.5

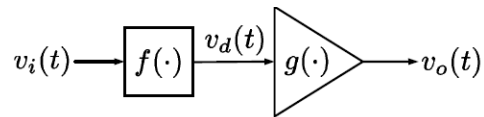

Fig.5. cascaded of amplifier and pre-distortion unite.

If $v_d(t)$ is the time domain output signal of high power amplifier, the total output of the system is expressed by Eq.7.

$$v_o(t) = g(f(v_i(t))v_i(t))f(v_i(t))v_i(t) \quad (7)$$

It is cleared that the high power amplifier is linear when the mount of G in Eq.8 is constant.

$$G = g(f(v_i(t))v_i(t))f(v_i(t)) \quad (8)$$

A pre-distortion system changes the shape of input data of amplifier so that the total characteristic of system is linear. In other words we cascade two non-linear systems so that the output to input of the whole system is linear. This will be done only if the power amplifier functions near its saturation point.

For linearization of a TWTA power amplifier, in 64-QAM modulation, a pre-distraction system is designed, with the following design steps.

Suppose that we express the amplitude and phase of every symbol in 64-QAM modulation by Eq.9.

$$x(t) = A(t) \cos(w_c t + \phi(t)) \quad (9)$$

We can describe the output of the amplifier and pre-distortion by Eq.10.

$$y(t) = f_{TWT}(A(t)FA_{PD}(A(t)))\cos(w_c t + FP_{PD}(A(t)) + P_{TWT}(A(t)FA_{PD}(A(t)) + \varphi(t)) \quad (10)$$

f_{TWT} : function of TWTA AM/AM conversions.

P_{TWT} : function of TWTA AM/PM conversions.

FA_{PD} : function of PD amplitude.

FP_{PD} : function of PD phase.

As the ration of output to input should be constant, the conditions in Eq.11 should become true:

$$\begin{cases} f_{TWT}(A(t)FA_{PD}(A(t))) = kA(t) \\ FP_{PD}(A(t)) + P_{TWT}(A(t)FA_{PD}(A(t))) = 0 \end{cases} \quad (11)$$

Therefore Eq.12 shows the relationship between the amplitude and the phase of pre-distorter:

$$\begin{cases} FA_{PD}(A(t)) = \frac{1}{A(t)} f_{TWT}^{-1}(kA(t)) \\ FP_{PD}(A(t)) = -P_{TWT}(A(t)FA_{PD}(A(t))) \end{cases} \quad (12)$$

$$f_{TWT}^{-1}(r) = \frac{\alpha_a}{2\beta_a r} + \sqrt{\frac{\alpha_a^2}{4\beta_a^2 r^2} - \frac{1}{\beta_a}} \quad (13)$$

Fig.6 illustrates the block diagram of designed Pre-distorter, to calculate 64-QAM symbols.

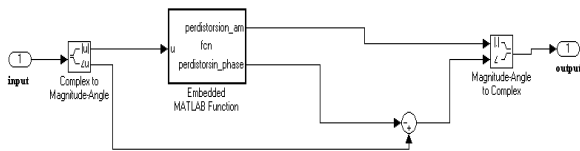

Fig.6. Pre-distorted system

4. System Model

A GEO satellite link in 30GHz is utilized for testing of a pre-distorter. Pseudo random data is used as input beside 64-QAM modulation. The pre-distorter is located before TWTA, with the parameters described before. The back-off of system is 1dB, and the free space loss is almost 213dB. The noise temperature in receiver is 60°K. The utilized pulse shaping is raised-cosine and the test is done with and without pre-distorter. Fig. 7 illustrates the simulation block diagram, used for the simulation with MATLAB/Simulink. The random binary streams passing through a raised-cosine filter and a 64-QAM modulator are sent to the input of the pre-distortion sub-system. We use Saleh model for TWTA according to the parameters shown in Eq.5 and Eq.6. Ultimately, the spectrum

parameters and the amount of BER are measured after receiving the signal via satellite link.

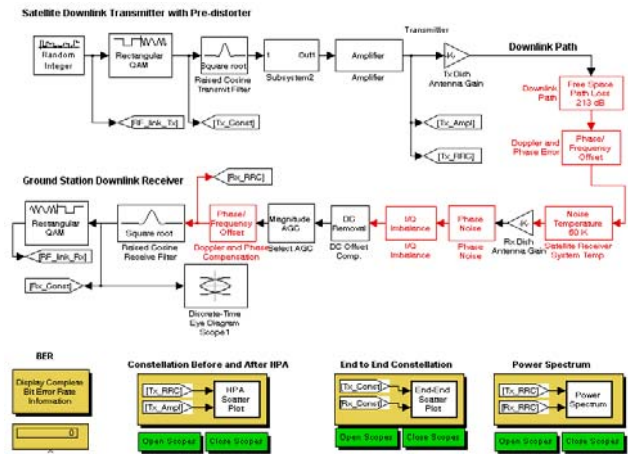

Fig.7. Simulink Model

Fig.8 and Fig.9 illustrate the affect of non-linearity and also the linearization affect by the pre-distorter in the simulation respectively. Fig. 8 shows the spectrum of transmitted signal, after the power amplifier without pre-distortion. Fig.9 shows that the level of first side lobe in received signal with pre-distorter is 20dB lower than the received signal without pre-distorted also the bandwidth is half of the non pre-distorted state.

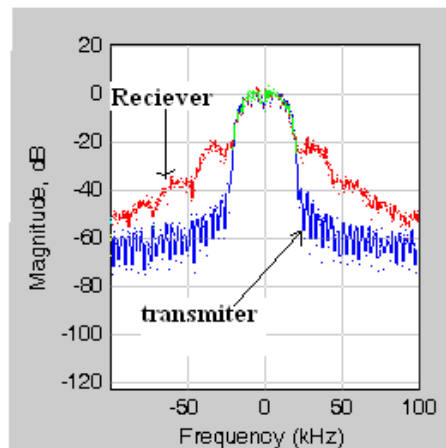

Fig.8. Spectrum in receiver and transmitter with nonlinear amplifier without using linearizer.

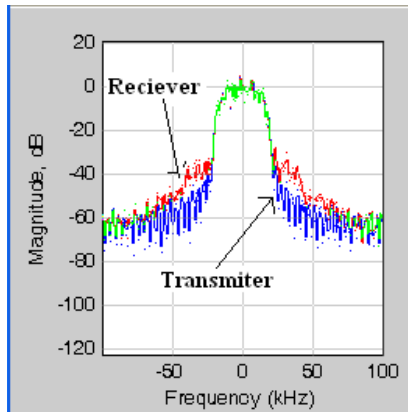

Fig.9. Spectrum in receiver and transmitter with nonlinear amplifier with using linearizer.

The effect of linearization can be evaluated by the eye-diagram of the system for output symbols in two stated. As it is seen in Fig.10 and Fig.11, the eye-opening is much more in the linearized system. In Fig.10, the eye-diagram is illustrated, while the power amplifier is non-linear, and in Fig.11 the eye-diagram of the power amplifier is illustrated, when a pre-distortion system is cascade with the power amplifier.

Fig.12 and Fig.13 show the advantages of using data pre-distortion in term of BER performance for different roll-off factor with and without data pre-distortion. As it is illustrated in Fig.12, the amount of error is minimums when $\alpha = 0.5$. When the amount of α is large, and consequently the bandwidth and the noise power is increased, the amount of BER is increased. Fig.13 illustrates the amount of BER without pre-distortion. Obviously, as the amount of back-off is 1dB, and also 64-QAM modulation is sensitive to non-linearity of TWTA, the amount of BER is high. Comparing Fig.12 and Fig.13, the amount of BER is improved by 3.5×10^5 . This result enables the 64-QAM modulation scheme to be efficiently utilized in satellite communication systems not worry about non-linear distortion.

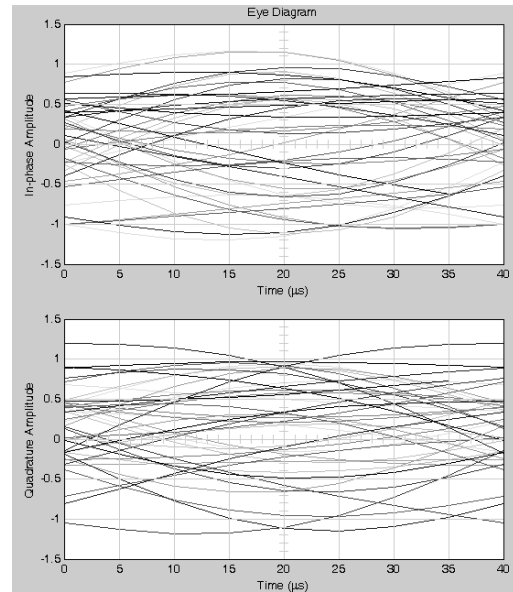

Fig 10. eye diagram in receiver with nonlinear amplifier without using linearizer.

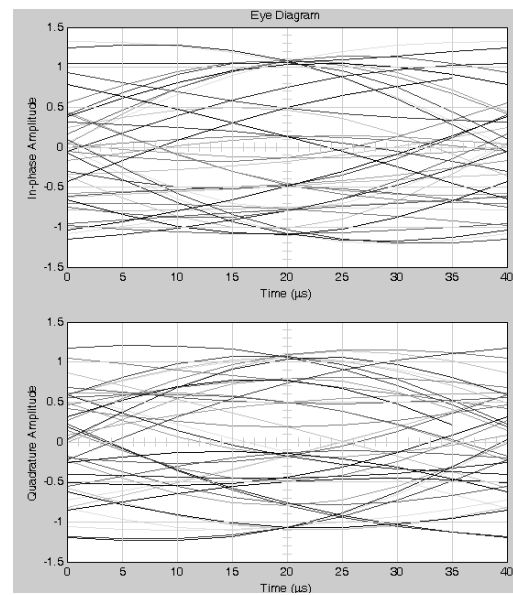

Fig 11. eye diagram in receiver with nonlinear amplifier with using linearizer.

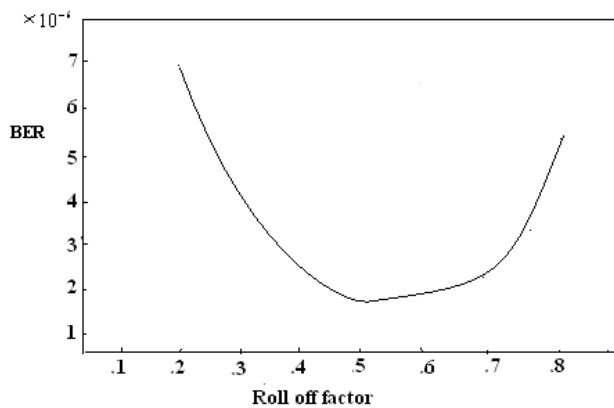

Fig.12. BER for different roll off factor with Pre-distortion

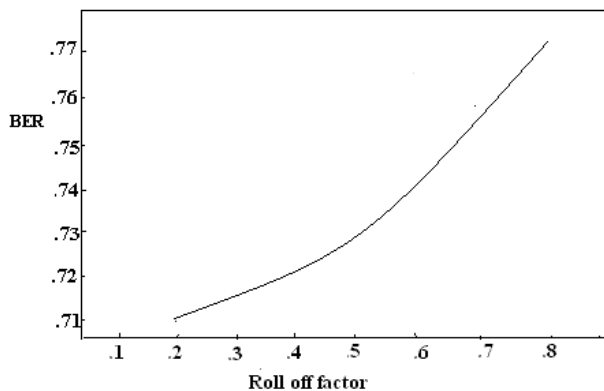

Fig.13. BER for different roll off factor without Pre-distortion

In the method, presented in [12] for DVB-MODEM with QPSK modulation, the side lobe is improved about 10dB. In the method presented in [13] with 16-QAM for mobile satellite, the amount of improvement of the side lobes is 13dB. In [14] the pre-distortion method for linearization in 16-QAM modulation and without roll-off parameter is implemented. The results of simulations show that the method, offered in this paper, improves the amount of side lobe by 20dB, with considering the roll off affect. Therefore, the offered method confirms a better performance than the above references.

5. Conclusion

In this paper the efficiency of linearization for baseband pre-distortion in 64-QAM modulation, utilized in Ka-band GEO satellite link for DVB-RCS services, is investigated. A TWTA power amplifier with about 1dB back-off is used in this satellite link, and the spectrum and eye-diagram in both transmitter and receiver side are evaluated. Simulation results show that satellite communication link can benefit from 64-QAM modulation schemes, using our

pre-distortion techniques. Also, this method for data pre-distortion can be used for higher level modulation.

References

- [1] G. Copeland, Digital Power Amplifier Linearization, Texas Instruments Inc., 2003.
- [2] R. Sperlich, "Adaptive Power Amplifier Linearization by Digital Pre-Distortion with Narrowband Feedback using Genetic Algorithms" Doctoral Thesis, School of Electrical and Computer Engineering Georgia Institute of Technology August 2005.
- [3] R.Schornstaedt, N. Rozario, C.Hayes, J. Seiter, and A. Katz, "Performance of Multi-Carrier 16-QAM Over a Linearized TWTA Satellite Channel", 20th AIAA International Communication Satellite Systems Conference and Exhibit, 12-15 May 2002, Montreal, Quebec, Canada.
- [4] M.Cote, L.Erup, M.Lambert, N.McSparron, "Implementation Challenges and Synergistic Benefits of DVB-RCS and DVB-S2", Digital Video Broadcasting over Satellite: Present and Future, 2006. The Institution of Engineering and Technology Seminar, Nov. 2006, pages: 21-33, London, UK.
- [5] A. Katz, "TWTA Linearization", The Microwave journal, Vol. 39, No 4, pp. 78-90, April 1996.
- [6] H. Alasady, M. Ibnkahla, A. Batada, "A Simple Data Pre-Distortion Technique for Satellite Communication: Design & Implementation on Altera DSP Board", CF-SAT031505-1.0, 2005.
- [7] A. Saleh, "Frequency- Independent and Frequency- Dependent Nonlinear Models of TWTA Amplifiers", IEEE Transactions on Communications, Vol. 29, No 11, Nov. 1981.
- [8] Ernst Aschbacher, "Prototype Implementation of two efficient low-complexity Digital Pre-distortion Algorithms", EURASIP Journal on advance in signal processing, Vlo.2008, Article ID 473182.
- [9] Young Yun Woo, "Adaptive Digital Feedback Pre-distortion Technique for Linearizing power Amplifier", IEEE Transactions on Microwave Theory and Techniques, VOL. 55, NO.5, May 2007.
- [10] Nima Safari, "Block based Predistortion for Amplifier Linearization in Burst Type Mobile satellite Communications", EUMW 2005.
- [11] Jianing Zhao, "Error Analysis and Compensation Algorithm for Digital Predistortion Systems", Pirs Online, VOL.2, No. 6, 2006.
- [12] Tien M. Nguyen, "Modeling of HPA and HPA Linearization Through a Predistorter", IEEE Transactions on Broadcasting, 49(2), pp. 132-141 (Jun. 2003).
- [13] Nima Safari, "Block based Predistortion for Amplifier Linearization in Burst Type Mobile satellite Communication", European Microwave Conference (EuMC) No35, Paris, FRANCE vol. 54 (2), no 6 (334 p.) 2006.
- [14] Hisham Alasady, "A simple Data Pre-distortion technique for satellite Communication: Design & Implementation on Altera DSP Board", CF-SAT031505-1.0, 2005.

Acknowledgments

This research was supported by Iran Telecommunication Research Center.



Sojoodi Sardrood Parvin received the B.S. degree in Communication Engineering from Tehran Polytechnic University 2001. During 2002 until now, she stayed in Iran TeleCommunication Research Center (ITRC), Ministry of Posts and Telecommunications of Iran to study satellite RF links, next generation access network, Ethernet technology in communication network. She is still working on the similar fields.



Reza Solat received the B.S. degree in Electrical Engineering from Isfahan University of Technology in Iran in 1990 and M.S. degree in Communication from Khajeh Nasir Tousi University of Technology in Iran in 1995. During 1995-2008, he stayed in Iran Telecommunication Research Center (ITRC) as a Project Manajer in satellite communication systems, and

Modulation & Coding.



Payman Parvand received the B.S. degree in Electrical Engineering from Iran University of Science & Technology in 1988. During 1990 until now, he has stayed in Iran Telecomm. Research Center, Ministry of ICT of Iran to research on Satellite Communications, Subsystems, Technologies, and Microwave and Milliliter RF devices etc. He is still working on the similar fields.