

# Predicting the need for blood during cardiopulmonary bypass

AR Coetzee, JF Coetzee

Department of Anesthesiology and Critical Care, School of Medicine, Faculty of Health Sciences, University of Stellenbosch, South Africa

## Abstract

**Background:** Haematocrit (Hct) values <18%-20% during cardiopulmonary bypass ( $Hct_{CPB}$ ) are potentially unsafe. **Aims:** 1. To predict when banked blood should be pre-issued. 2. To evaluate the sparing-effect of banked-blood by autologous blood transfusions. **Methods:** An equation for prediction of  $Hct_{CPB}$  ( $Hct_{pred}$ ), based on weight and pre-operative haemoglobin concentration was used to forecast which patients would develop  $Hct_{CPB} \leq 20\%$ . Perioperative blood and fluid administration were recorded in 80 patients requiring CPB. Blood and fluid administration strived for  $Hct_{CPB} \geq 18\%$  on CPB and 33% in the ICU. **Results:**  $Hct_{pred}$  bias and precision were 2.6% and 13.1%. A  $Hct_{pred}$  cut-off value of 23% reliably forecast a  $Hct_{CPB} \leq 20\%$  (15 patients with mean  $Hct_{CPB}$  16.5%). Despite a 31% false positive rate (FPR), there is emphasis on safety associated with the 23%  $Hct_{pred}$  cutoff-point. (100% negative predictive value; zero negative likelihood ratio). Applying the same predictive criterion to all blood transfusions performed in the OR, increased positive predictive values from 43% to 63% so that the FPR decreased to 24%. Autologous transfusion comprised 72% of transfused blood and was the only transfusion in 67% of patients. Banked-blood recipients weighed less and had lower pre-operative haemoglobin concentrations,  $Hct_{pred}$  and  $Hct_{CPB}$ . They received larger transfusions of which autologous blood formed 46%. **Conclusions:** 1. It is possible to predict which patients will develop potentially low  $Hct_{CPB}$ . 2. Autologous transfusions result in considerable reduction of banked blood usage.

**Key words:** Haematocrit, Blood transfusion, Autologous, Cardiopulmonary bypass, ROC curve, Predictive value of tests

Autologous blood transfusions are advantageous because they introduce cost savings and reduce the risks for immune reactions and infections.<sup>1</sup> Furthermore, autologous blood transfusions relieve pressure on scarce banked-blood resources. In our region, centralized banks distribute blood to surrounding hospitals and whereas this is certainly advantageous with regard to cost- and quality control, it imposes limitations when blood is urgently required some distance from the depot.

Supply logistics of banked blood may be problematic during cardiac surgery because of the haemodilution and decreased oxygen delivery that occurs on initiation of cardiopulmonary bypass (CPB). In spite of patient cooling during CPB that brings about decreased whole body oxygen consumption, there is a time lapse before stable hypothermia is established. Oxygen delivery may be insufficient during that period, if haemoglobin concentration is low and pump flow has not reached predicted values. There is therefore a theoretical possibility of anaerobic metabolism. However, whether such an event is necessarily detrimental, is less clear.<sup>2-5</sup> It is therefore often considered prudent to have blood ready in the operating room at the time of going onto bypass in order to circumvent the potential risk set out above. On the other hand, the question of blood being issued and not used, is a cost consideration that cannot be ignored. The purpose of this study was firstly to determine whether it is possible to predict which patients would require blood to be available in the operating room prior to CPB and secondly, to evaluate the effectiveness of autologous blood transfusions during open heart surgery.

## Methods

After obtaining approval from the Ethics Committee of the Faculty of Health Sciences, informed, written consent was obtained from 80 consecutive patients scheduled for cardiac surgery employing CPB, to whom care was provided by the first author.

Patients qualified for inclusion to the study if:

- They were to undergo cardiopulmonary bypass (CPB),
- were older than 18 years,
- had no objection to receiving blood according to the existing standing protocol for cardiac surgery,
- had no clotting abnormality which could affect the study.

There was no obvious reason why the patient could not be managed as set out in the blood management protocol (see later), for example a particularly small patient with a low preoperative haemoglobin concentration.

Patients were interviewed and physically examined on the day before surgery. Special examinations included chest X-ray, full blood count (including haemoglobin concentration in g/dl), clotting profile (including bleeding time), 12-lead electrocardiogram, results from cardiac catheterization studies, stress electrocardiography (if applicable) and echocardiographic results. (if applicable). Of the medications that patients were receiving, only angiotensin inhibitors or angiotensin receptor blocking drugs were omitted on the day of surgery.

Premedication consisted of morphine and phenergan. In the operating room intravenous, arterial and central venous lines (as well as a pulmonary artery catheter if so indicated) were inserted under local anaesthesia. Acebutolol was given intravenously if there was no overt contraindication to the use of beta-adrenergic blockers. In

## Correspondence:

Prof AR Coetzee  
email: arc1@sun.ac

addition, esmolol was given before intubation.

Anaesthesia was induced with fentanyl administered by target-controlled infusion\*, aiming for a blood concentration of 4 ng/ml followed by propofol (1 mg/kg). Muscle relaxation was obtained with vecuronium, the trachea intubated and the patient's lungs ventilated with oxygen (50%) and air. Sevoflurane or halothane was used for maintenance of anaesthesia.

Fluid was administered according to a predetermined protocol as follows:

- Intravascular volume replacement: (Weight in kg x 2 x number of hours nil per mouth in ml).
- Maintenance: 2 ml/kg per hour during surgery.
- After a total of 30 ml/kg crystalloids had been administered, hetastarch (7 ml/kg) was given.
- If the patient had been receiving intravenous heparin before surgery, fresh frozen plasma (10 ml/kg) was administered prior to further heparinization.

This protocol for intravenous fluid therapy was adjusted as required to maintain haemodynamic stability following changes in intravascular volume.

Patients were heparinized with 2 mg/kg heparin and the ACT was confirmed to be greater than 400 seconds before commencing CPB. Patients were cooled to 32°C and the pump flow controlled at 2.2 lmin<sup>-1</sup>m<sup>-2</sup>. Mean arterial pressure was maintained within 25% of the preoperative mean blood pressure using phenylephrine injected intravenously or isoflurane vaporized into the CPB (depending on the patient-pump pressure differential, flow and line pressure). Alpha stat blood gas analysis was used. The CPB reservoir volume was kept at a safe minimum and extra fluid administration was done in conjunction with the anaesthesiologist. Blood loss was conserved using a Dideco Electra Cell Saver® (Marindola, Italy) according to the operating instructions.

After surgery, patients were rewarmed to a nasopharyngeal temperature of 36°C and weaned from CPB with the aid of administration of dobutamine or adrenaline, nitroglycerine or sodium nitroprusside, as required, depending on the state of the patient's circulation. Heparin was reversed with protamine sulphate aiming to achieve a post-CPB ACT value that was within 10 % of the preoperative value.

### Management of blood loss

- Blood was crossmatched and screened for all patients but was not issued unless requested.
- The aim was to maintain the haematocrit at 20% during CPB (Hct<sub>CPB</sub>). If the Hct<sub>CPB</sub> was more than 18 % (but less than 20 %), and the blood lactate did not increase during repeated measurements, banked blood was not administered during CPB.
- In the post-CPB period the aim was that the patient should arrive in the intensive care unit with a haematocrit of 33%. If administration of saved autologous blood had not achieved this value, or if the clinician had reason to suspect that it may not have been achieved, blood was ordered and administered.

### Data analysis

It was expected that patients' weight and pre-operative haemoglobin could be used to predict their Hct<sub>CPB</sub> and that these predicted values could be employed to decide on the necessity for blood to be available

in the OR. We assumed that dilution by the priming fluid of the CPB machine, as well as by intravenously-administered fluids, are the primary determinants of patient's Hct<sub>CPB</sub> values. The following expression was used to predict each patient's Hct<sub>CPB</sub>:

$$\text{Hct}_{\text{pred}} = \frac{\text{Weight} * [\text{Hb}] * 200}{((\text{weight} * 70) + 4000)} \quad (\text{Equation 1})$$

The methods by which this expression was derived are described in the Appendix at the end of this paper.

Agreement between Hct<sub>pred</sub> and Hct<sub>CPB</sub> were evaluated by calculating the prediction error (bias) and absolute prediction error (precision) for each patient, whereby:

$$\text{Prediction error (PE)} = \frac{100 * (\text{Hct}_{\text{CPB}} - \text{Hct}_{\text{pred}})}{\text{Hct}_{\text{pred}}}$$

and Absolute prediction error (APE) = the absolute value of the PE.

Receiver operating characteristic (ROC) analysis was performed using the statistical software package MedCalc® (Version 7.4 © 2000, author Frank Schoonjans, www.medcalc.com). The Hct<sub>pred</sub> was used as the variable of interest and the classification variable was a measured Hct<sub>CPB</sub> of 20% or less.

Intergroup comparisons were performed using t-tests on continuous numerical data. A p value of less than 0.05 (two sided test) was regarded as indicating a significant difference. Pearsons product moment correlation coefficient was used to test for an association.

## Results

### Performance of the prediction equation

Figure 1 depicts the agreement between Hct<sub>pred</sub> and Hct<sub>CPB</sub> values. The correlation coefficient (r) was 0.635 (p < 0.001) (r<sup>2</sup> =

**Figure 1: Graph depicting the agreement between measured haematocrit during cardiopulmonary bypass and the haematocrit predicted by equation-1. The diagonal line is the line of identity, which indicates perfect agreement.**

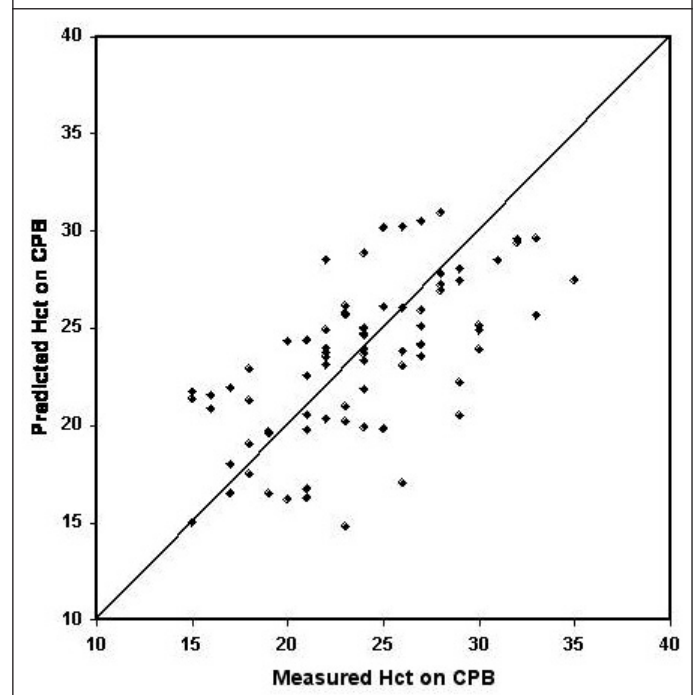

\* Stelpump version 1.7 for DOS. Authors Johan Coetzee and Ralph Pina, University of Stellenbosch.

0.40). The mean prediction error (bias) was 2.6% with 95% confidence interval (95% CI) 0.73% to 4.6%. The mean absolute prediction error (precision) was 13.1% (95% CI 11.8% to 14.4%). Figure 2 is a graph of the differences (between measured and predicted haematocrit values) versus measured haematocrit. The mean difference was 0.4% (standard deviation 3.7%; 95%CI -0.01% to 0.81%). At the extremes of haematocrit values the prediction equation tended to overpredict at low values and underpredict at high values, so that there was a significant positive correlation between measured haematocrit and the differences between measured and predicted values due to the presence of several outliers ( $r = 0.57, p < 0.001$ ).

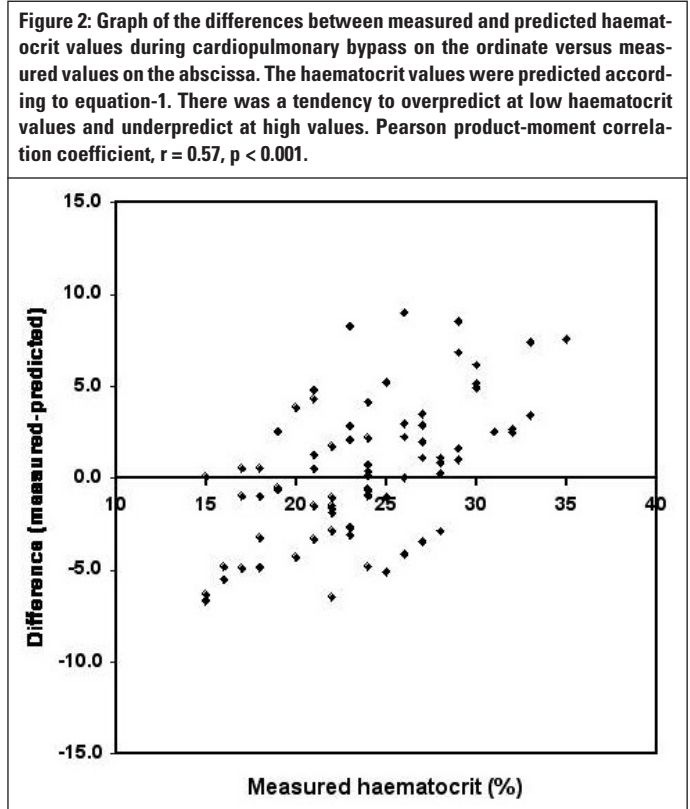

**Transfusion results**

Statistics for all 80 patients are presented in Table 1. The mean measured haematocrit values for all 80 patients at the beginning and the end of CPB were 23.8% and 23.6% respectively. The mean volume of intravenous fluids administered was 1662 ml (SD 400) and the mean CPB prime was 1574 ml (SD 172). Satisfactory haematocrit values were obtained by the time patients arrived in the ICU and after 24 hours (mean 32% and 36.8% respectively). Mean transfused blood volumes were 295 ml and 775 ml of banked and autologous blood respectively. Autologous blood comprised 72% of the total amount of transfused blood.

There were 15 patients whose Hct<sub>CPB</sub> values were 20% or less (mean 16.5%; SD 2.6%). The mean Hct<sub>CPB</sub> of the remaining 65 patients was 25.4% (SD 3.6%). Table 2 depicts the results from these two groups. The patients whose Hct<sub>CPB</sub> values were 20% or less weighed less than the remainder (mean weight 70.5 kg vs 85.7 kg) and they had lower pre-operative haemoglobin concentrations (mean [Hb] 12.5 vs 14.3 g/dL). Prediction errors tended to be negative for those with Hct<sub>CPB</sub>

**Table I: Results from all 80 patients. Std Dev = Standard deviation; 95% Conf. Interval = 95% confidence interval of the mean value; Pre-op Hb = Pre-operative hemoglobin concentration; Hct = haematocrit (%); CPB = cardiopulmonary bypass; ICU = intensive care unit; Percent error = bias of the predicted haematocrit on CPB; Absolute percent error = Precision of the predicted Hct on CPB.**

	Mean	Std. Dev.	95% Conf. interval
Age (years)	59.7	11.4	50.4 to 61.0
Weight (kg)	82.8	17.8	80.8 to 84.8
Pre-op Hb (g/dL)	14.0	1.5	13.8 to 14.2
Pre-CPB i.v. crystalloids (ml)	1452	392	1408 to 1496
Pre-CPB i.v. colloids (ml)	206	290	173 to 238
CPB Prime (ml)	1574	173	1555 to 1594
CPB Added volume (ml)	398	497	343 to 453
Total pre-CPB I.V. fluids (ml)	3635	644	3563 to 3707
Predicted Hct on CPB (%)	23.5	4.0	23.1 to 23.9
Measured Hct on CPB (%)	23.8	4.6	23.3 to 24.3
Percent error (%)	2.6	17.2	0.7 to 4.5
Absolute percent error (%)	13.1	11.4	11.8 to 14.4
Hct at end of CPB (%)	23.6	4.2	23.1 to 24.1
Hct in ICU	32.0	5.7	31.4 to 32.6
Hct at 24 hours	36.8	4.6	36.3 to 37.3
Autologous blood transfused (ml)	775	247	747 to 803
Banked blood transfused (ml)	295	478	242 to 348
Total volume blood transfused (ml)	1060	461	1009 to 1112
Autologous blood (% of total)	82.7	26.6	79.7 to 85.7

**Table II: Comparisons between patients who had haematocrit values of less than 20% on cardiopulmonary bypass with those with greater haematocrit values. Results are presented as mean (standard deviation). P = p value of t-test. 95% CI of difference = 95% confidence interval of the difference between means. Hb = haemoglobin; Hct = haematocrit; CPB = cardiopulmonary bypass; Percent error = percent prediction error (bias); Absolute percent error = absolute value of the prediction error (precision); Total fluids = volume of fluids administered intravenously (IV) prior to CPB, as well as volume of CPB prime.**

	Hct < 20% During CPB	Hct >= 20% During CPB	P (95% CI of difference)
Number in group	15	65	
Age (years)	61.8 (13.1)	59.3 (11.0)	0.4 (-3.9 to 9.1)
Weight (kg)	70.5 (14.0)	85.7 (17.5)	0.002 (-24.8 to -5.5)
Pre-op Hb (g/dL)	12.5 (1.0)	14.3 (1.5)	<0.001 (-2.6 to -1.0)
Hct measured on CPB (%)	16.5 (2.5)	25.4 (3.6)	<0.001 (-10.8 to -6.9)
Hct measured at end of CPB (%)	18.7 (3.1)	24.7 (3.6)	<0.001 (4.1 to 8.1)
Predicted Hct (%)	19.5 (2.6)	24.5 (3.5)	<0.001 (-7.0 to -3.1)
Percent error (%)	-11.0 (14.0)	5.8 (16.4)	<0.001 (-25.9 to -7.7)
Absolute percent error (%)	23.8 (11.0)	12.9 (11.5)	0.78 (-5.6 to 7.4)
Total fluids: IV + CPB prime (ml)	3266 (460)	3720 (653)	0.013 (99 to 809)
Total fluids: IV + CPB prime (ml/kg)	47.3 (7.2)	45.1 (11.3)	0.475 (-8.3 to 3.9)

values of 20% or less and were positive for the remainder, reflecting the tendency for the prediction equation to overpredict very low haematocrit values and underpredict high values. There were no significant differences in absolute prediction errors, nor in fluids administered prior to CPB when the latter was expressed in terms of volume per unit body weight.

There were 26 patients who received banked blood transfusions in the OR (including the intra- and the post-CPB periods). For the remaining 54 patients (67.5% of all the patients), autologous blood transfusion was sufficient. Table 3 depicts the statistics of those who received banked blood and those who did not. Banked blood recipients weighed less, and had lower pre-operative haemoglobin concentrations,  $Hct_{pred}$  and measured  $Hct_{CPB}$ . These patients also received larger transfusions of which autologous blood formed 46% of the total volume of blood transfused.

**ROC curve analysis**

Table 4 presents results of the ROC curve analysis. The prevalence of patients with  $Hct_{CPB} < 20\%$  was 0.188. The area under the ROC curve (Figure 3) was 0.87 (95% confidence interval 0.78 to 0.93). Because the confidence interval does not include the 0.5 value, there is evidence that the  $Hct_{pred}$  did have the ability to distinguish be-

**Table III: Comparisons between patients who received banked blood during surgery and those who did not. Results are presented as mean (standard deviation). P = p value of t-test. 95% CI of difference = 95% confidence interval of the difference between means.**

**Hb = haemoglobin; Hct = haematocrit; CPB = cardiopulmonary bypass; ICU = intensive care unit.**

	Banked blood administered in OR	No banked Blood administered in OR	P (95% CI)
Number in group	26	54	
Age (years)	63.1 (12.3)	58.1 (10.7)	0.06 -0.2 to 0.4
Weight (kg)	73.0 (20.0)	87.6 (14.7)	<0.001 (6.7 to 22.5)
Pre-op Hb (g/dL)	12.7 (1.2)	14.5 (1.4)	<0.001 (1.2 to 2.4)
Predicted Hct on CPB	20.2 (3.6)	25.1 (3.0)	<0.001 -6.4 to -3.4
Measured Hct on CPB	19.9 (4.0)	25.7 (3.6)	<0.001 -7.6 to -4.1
Autologous blood transfused (ml)	701 (259)	810 (235)	0.07 -226 to 8.6
Banked blood transfused (ml)	906 (382)	0	0.00 (803 to 1009)
Total volume blood transfused (ml)	1581 (370)	810 (235)	<0.001 635 to 907
Autologous blood (% of total)	45.5 (13.8)	100	0.00 (42.6 to 48.3)
Hct in ICU (%)	32.9 (6.3)	31.6 (5.5)	0.38 -1.5 to 4.0
Hct at 24 hours (%)	36.9 (4.4)	36.8 (4.8)	0.91 -2.1 to 2.4

**Figure 3: The receiver operating characteristic (ROC) curve for calculated probabilities of obtaining measured haematocrit values of <20% during cardiopulmonary bypass. The curve was constructed by calculating the sensitivity and false positive rate (100 – specificity) for each possible cut-off point for the predicted haematocrit ( $Hct_{pred}$ ) between  $Hct_{pred}$  values of 15% and 31% according to equation-1 (see Table 4). The area under the curve is 0.869 (95% confidence interval 0.775 to 0.934). The dotted line of identity indicates 50% prediction probability i.e. the line along which a test has no discriminatory power. The asterisk indicates the selected optimum cut-off point, namely a  $Hct_{pred}$  of 23%.**

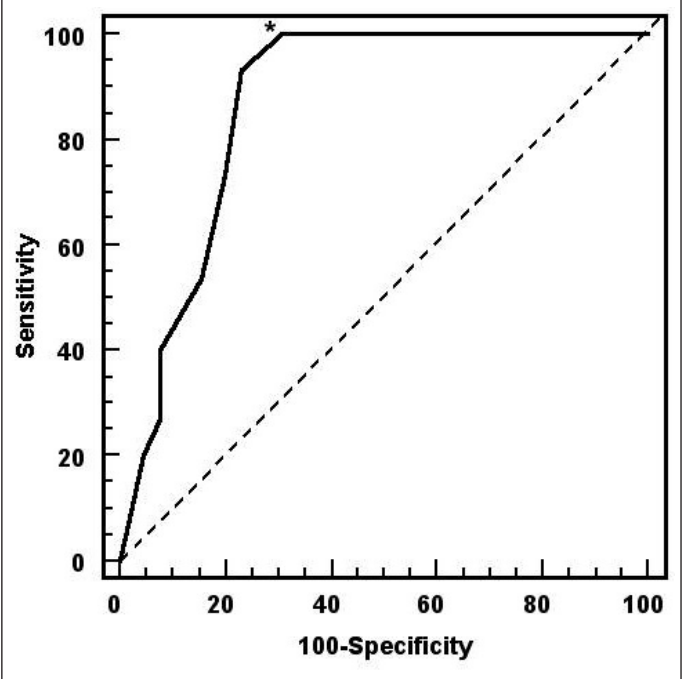

tween those who developed  $Hct_{CPB}$  less than 20% and those whose  $Hct_{CPB}$  was equal to or greater than 20%. The results may be interpreted as follows:

**Sensitivity:** Prior to performing the test, it is possible to be 100% sure of predicting the need to have blood present in the OR blood before CPB. However, on 95% of occasions, the predictability in the population will vary from 78% to 100%.

**Specificity:** Prior to performing the test, the mean probability for no blood being required is 69%, but on 95% of occasions this will vary between 57% and 80%.

**Postive predictive value:** If the test is positive, there is a 43% probability that blood will need to be present in the OR.

**Negative predictive value:** If the test is negative, the probability for blood being required is very low (indeed ruled out).

**Positive likelihood ratio:** A patient who has a positive test and needs blood, is three times more likely to have required blood than a patient who tests negatively and does not require blood.

**Negative likelihood ratio:** If a patient has a negative test the necessity for blood to be present in the OR is very small.

These results are graphically depicted in Figure 4 wherein it is shown that if a  $Hct_{pred}$  of 23% or less (“postive test”), is chosen as the cut-off point for this sample of patients, all the patients who subsequently devolved  $Hct_{CPB}$  of 20% or less were correctly predicted (quadrants



**Table IV: Results of receiver operating characteristic curve analysis:**

Prediction probabilities are depicted for cut-off values for predicted haematocrit (Hct<sub>pred</sub>) between 15% and 31%. The classification variable for a positive or negative test was a measured haematocrit (Hct<sub>CPB</sub>) of less than 20%. The selected optimum cut-off value (Hct<sub>pred</sub> £ 23%), to distinguish between a positive or negative test, is indicated in bold type.

Positive group: Sample size = 15; Negative group: Sample size = 65

Disease prevalence (%) = 18.8

Area under the ROC curve = 0.869; Standard error = 0.042; 95% Confidence interval = 0.775 to 0.934;

+LR = Positive likelihood ratio; -LR = Negative likelihood ratio;

+PV = Positive predictive value; -PV = Negative predictive value.

Hct <sub>pred</sub>	Sensitivity (95% CI)	Specificity (95% CI)	+LR	-LR	+PV	-PV
< 15	0.0 (0.0- 22.0)	100.0 (94.4-100.0)		1.00		81.2
<=15	6.7 (1.1- 32.0)	98.5 (91.7- 99.7)	4.33	0.95	50.0	82.1
<=16	20.0 (4.6- 48.1)	95.4 (87.1- 99.0)	4.33	0.84	50.0	83.8
<=17	26.7 (8.0- 55.1)	92.3 (82.9- 97.4)	3.47	0.79	44.4	84.5
<=18	33.3 (11.9- 61.6)	92.3 (82.9- 97.4)	4.33	0.72	50.0	85.7
<=19	40.0 (16.4- 67.7)	92.3 (82.9- 97.4)	5.20	0.65	54.5	87.0
<=20	53.3 (26.6- 78.7)	84.6 (73.5- 92.4)	3.47	0.55	44.4	88.7
<=21	73.3 (44.9- 92.0)	80.0 (68.2- 88.9)	3.67	0.33	45.8	92.9
<=22	93.3 (68.0- 98.9)	76.9 (64.8- 86.5)	4.04	0.09	48.3	98.0
<=23	100.0 (78.0-100.0)	69.2 (56.6- 80.1)	3.25	0.00	42.9	100.0
<=24	100.0 (78.0-100.0)	50.8 (38.1- 63.4)	2.03	0.00	31.9	100.0
<=25	100.0 (78.0-100.0)	35.4 (23.9- 48.2)	1.55	0.00	26.3	100.0
<=26	100.0 (78.0-100.0)	24.6 (14.8- 36.9)	1.33	0.00	23.4	100.0
<=27	100.0 (78.0-100.0)	18.5 (9.9- 30.0)	1.23	0.00	22.1	100.0
<=28	100.0 (78.0-100.0)	13.8 (6.5- 24.7)	1.16	0.00	21.1	100.0
<=29	100.0 (78.0-100.0)	9.2 (3.5- 19.0)	1.10	0.00	20.3	100.0
<=30	100.0 (78.0-100.0)	3.1 (0.5- 10.7)	1.03	0.00	19.2	100.0
<=31	100.0 (78.0-100.0)	0.0 (0.0- 5.6)	1.00		18.8	

a and c in Fig. 4). However, 20 of the 35 patients (57%) whose Hct<sub>pred</sub> were 23% or less, did not require blood to be issued for CPB (false positives, quadrants a and b). Nevertheless, of the 65 patients who did not require prebooked blood, this was predicted correctly on 69% of occasions (true negatives, quadrants b and d).

**Discussion**

There are many reasons for curtailing heterogenous blood transfusion. These include availability and the high cost of blood products, as well as the ever present risk of antigen reactions and various infections, of which retroviral disease is currently of significant concern. Autologous blood transfusion is a common, safe and well established practice. It avoids many, if not all the risks and has the benefit of transfusing red cells that rapidly become functional. Furthermore, it relieves the constant pressure on the already limited supply of banked blood. There is, however, some debate on the ability of autologous blood transfusions (as used in this study) to reduce costs.<sup>6-8</sup> A decision that clinicians are required to make involves the maintenance of a reasonable haematocrit during cardiopulmonary bypass. There is evidence that maintenance of a haematocrit at about 20% is safe clinical practice.<sup>2-5</sup> In agreement therewith, we have observed continuous increases in blood lactate concentrations at haematocrit values less than 18%–20%. We interpret this phenomenon as indicative of anaerobic metabolism that preferably should be avoided. Nevertheless in spite of the increased lactate, we have not detected any deleterious effects with regard to patient survival or quality of recovery. This was, however, not sought for in a prospective manner and clearly only represents an impression.

The problem that initiated the study was the fact that the blood bank facility is physically removed from the hospital in which the study was conducted. On requesting blood, it takes approximately 30 minutes for delivery to the operating room under ideal circumstances and in peak traffic, it may well take up to 1 hour. When going onto CPB, acute haemodilution takes place at a time when the patient has not been cooled to the 32°C temperature employed during surgery. This introduces the risk of tissue hypoxia if the oxygen delivery is insufficient because of a low haemoglobin. On the other hand, issuing blood routinely in an attempt to circumvent the problem, not only incurs extra cost but also places unnecessary strain on blood banking facilities.

**Figure 4: Graphical contingency table of patients who during cardiopulmonary bypass, developed haematocrit values (Hct<sub>CPB</sub>) of <20%. A "positive" test is a predicted haematocrit (Hct<sub>pred</sub>) of 23% or less. Each patient's Hct<sub>pred</sub> is graphically represented on linear scale along the ordinate and categorized along the abscissa.**

T+ = positive test; T- = negative test; D+ = Hct<sub>CPB</sub> of <20%; D- = Hct<sub>CPB</sub> ≥20%  
 FN = false negative tests; TP = true positive tests; FP = false positive tests;  
 TN = true negative tests.  
 Sens = sensitivity; Spec = specificity; FPR = false positive rate; PPV = positive predictive value; NPV = negative predictive value; +LR = positive likelihood ratio; -LR = negative likelihood ratio.

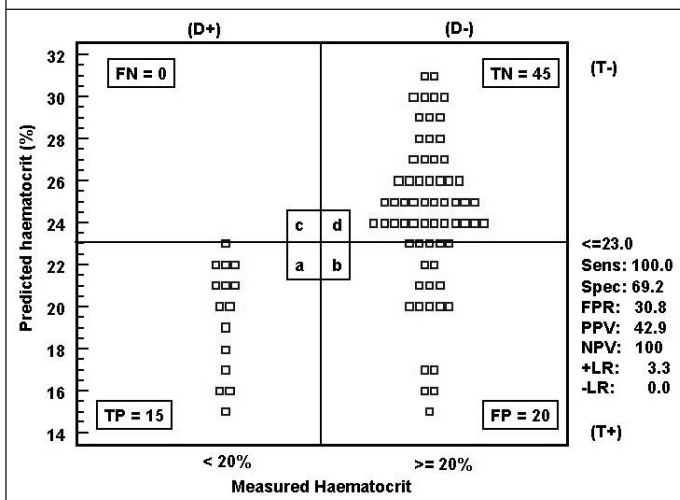

This purpose of this study was therefore to establish a simple clinical test that predicts the probability for requirement of blood to be available in the operating room at the time of initiating bypass. Given that the priming volume of the cardiopulmonary bypass machine is standard and fluid administration policy controlled, it was hypothesized that patient size and preoperative haemoglobin concentration would determine the extent of haemodilution that would occur.<sup>9-12</sup> The larger the patient and the higher the haemoglobin concentration, the less severe the dilution of the intravascular volume there should be. It was of less importance to predict which patients would require blood in the ICU as at that time drainage and other factors come into play. Furthermore, there is then sufficient time to order blood and the pressures on acute decisions as well as the limitations of the supply system become less important.

It appears from our results that choosing a predicted cardiopulmonary bypass haematocrit cut-off point of 23% would enable a clinician to decide on whether to order blood to be present in the OR before CPB with a moderate degree of confidence. This is indicated by the fairly high values for sensitivity, but there is a trade-off because of the 31% false positive rate and the only 43% positive predictive value. The latter two values indicate that about one third of blood ordered will not be required during CPB and will have an effect on cost. Nevertheless, from a safety point of view, (i.e. having the blood available when required), the high negative predictive value and low negative likelihood ratio indicate that a Hct<sub>pred</sub> greater than 23% will virtually exclude the necessity to ensure that blood be present in the OR on initiation of CPB. Selecting this cut-off point as a trigger to issue blood instead of routine issuing of blood for all patients, will relieve pressure on the blood bank, but this does not necessarily translate into cost savings as the latter will be offset by the cost of the cell-saver and it's consumables. The care-giver physician will always be required to make a personal choice whether to place emphasis on patient safety or on cost saving, thereby running the risk of not having blood available at short notice. By adjusting the predicted cutoff value (Table 4) a more conservative approach can be accommodated.

There is a small discrepancy between the cutoff Hct<sub>pred</sub> value of 23% to predict a value of 20% or less for Hct<sub>CPB</sub>. This is probably due to the tendency for equation-1 to overpredict the Hct<sub>CPB</sub> at the lower extremes. Overall, the haematocrit predictions were quite satisfactory. However, despite the small mean bias of 2.6%, there was considerable scatter in the data as revealed by Figures 1 and 2 as well as the low coefficient of determination (r<sup>2</sup>). This indicates considerable interpatient variability. Furthermore, simply multiplying patient-weight in kg with a factor of 70 (equation 2A) is most likely a oversimplified method to estimate blood volumes of patients scheduled for cardiac surgery, whose pre-operative blood volumes may vary from abnormally low as a result of diuretic therapy to abnormally large in the presence of fluid retention. There was a notable number of obese patients in whom such a calculation could perhaps lead to overestimation of blood volume. However, limiting the maximum weight to 90 kg or even to 100 kg in equation 1, did not improve agreement between measured and predicted haematocrit values.

There were 15 patients in whom no blood was transfused during CPB, but who required blood in the OR after bypass.

This comprises those patients in whom unexpected blood loss or unacceptably low haematocrit values occurred in the period after CPB. The mean Hct<sub>pred</sub> of these patients was 21% (SD 3.5%) and of these, only 4 patients had Hct<sub>pred</sub> values equal to or greater than 23%, (29%, 25%, 26% and 23%). It can therefore be argued that 12 of the 15 patients would have had blood ready for them in the OR in any event and that this fact would have reduced the amount of blood that would have been ordered but not used. A second ROC curve analysis was therefore performed where the classification variable was all blood transfusions in the OR (during and after CPB).

Results of the second analysis are shown in Figure 5. The area under the ROC curve was 0.85 (95% confidence interval 0.76 to 0.92). When the same criterion was used (Hct<sub>pred</sub> of 23% or less), this resulted in the classifications and probability calculations depicted in Figure 5. The false positive rate decreased from 31% to 24% (representing the proportion of patients for whom blood would have been ordered but not used in the OR). Sensitivity decreased from 100% to 84.6% which is to be expected, as unforeseen blood loss after CPB is often a random and unpredictable event. Whereas there was no significant increase in the positive likelihood ratio (3.3 and 3.5), the positive predictive value increased from 42.9% to 62.9%, indicating improved prediction probability of whether blood transfusion would be necessary. The low false negative rate (9.8%), high negative predictive value (91.1%) as well as the low negative likelihood ratio (0.20) are again indicative of a fair degree of safety in predicting when blood would not be needed in the OR.

We conclude that a simple calculation of predicted haematocrit during CPB can be used as a guideline for a decision as whether to ensure that blood should be immediately available in the OR with a fair degree of confidence. Applying the

**Figure 5: Graphical contingency table of patients who received transfusions of banked blood during cardiac surgery (during cardiopulmonary bypass (CPB) and after CPB). A "positive" test is a predicted haematocrit (Hct<sub>pred</sub>) of 23% or less. Each patient's Hct<sub>pred</sub> is graphically represented on a linear scale along the ordinate and categorized along the abscissa.**

T+ = positive test; T- = negative test;  
 D+ = Banked blood administered; D- = banked blood not administered.  
 FN = false negative tests; TP = true positive tests; FP = false positive tests;  
 TN = true negative tests.  
 Sens = sensitivity; Spec = specificity; FPR = false positive rate; PPV = positive predictive value; NPV = negative predictive value; +LR = positive likelihood ratio; -LR = negative likelihood ratio.

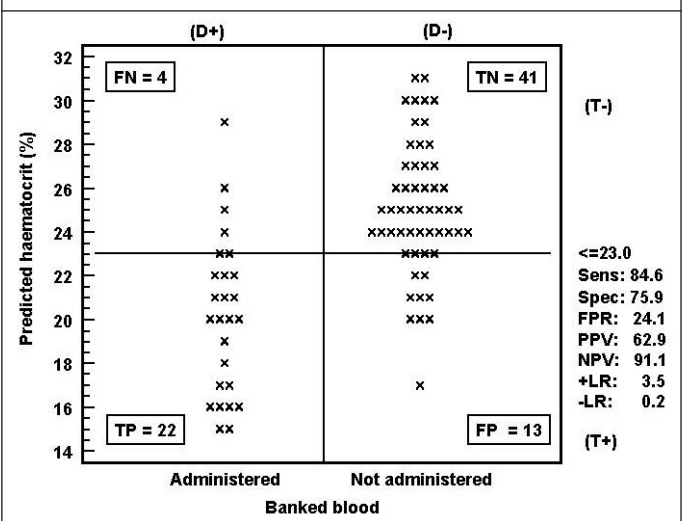

guideline can lead to considerable banked blood savings. The prediction encompasses transfusions that will be needed to maintain an adequate haematocrit during CPB (18% to 20%) as well as reasonably good predictions of transfusions that will become necessary in the OR after CPB. It should be emphasized that there will always be a "grey area" for decisions of this sort and the aim of this study was to minimize this grey area. Furthermore, the data can strictly speaking only be applied to circumstances similar to those under which the study was conducted, as certain features may differ, for example pump-prime volumes, application of autologous blood transfusions and blood loss during surgery. Therefore extrapolation beyond these circumstances should be done with caution.

## References

1. Moore RG, Laub GW. *Cardiopulmonary bypass, 2nd Edition*. Philadelphia, Lippincott Williams Wilkins, 2000, pp 105-30
2. Cohn LH, Fosberg AM, Anderson WP, Collins JJ, Jr.. *The effects of phlebotomy, hemodilution and autologous transfusion on systemic oxygenation and whole blood utilization in open heart surgery*. *Chest* 1975; 68: 283-7
3. Lawson NW, Ochsner JL, Mills NL, Leonard GL. *The use of hemodilution and fresh autologous blood in open-heart surgery*. *Anesth Analg* 1974; 53: 672-83
4. Nahas RA, Mundth ED, Tanae H, Buckley MJ, Austen WG. *Effect of hemodilution on left ventricular function with regional ischemia of the heart*. *Surg Forum* 1972; 23: 149-51
5. Tector AJ, Gabriel RP, Matericka WE, Oparah SS, Flemma RJ, Lepley D, Jr.. *Reduction of blood usage in open heart surgery*. *Chest* 1976; 70: 454-7
6. Hall RI, Schweiger IM, Finlayson DC. *The benefit of the Hemonetics cell saver apparatus during cardiac surgery*. *Can.J.Anaesth* 1990; 37: 618-23
7. McGill N, O'Shaughnessy D, Pickering R, Herbertson M, Gill R. *Mechanical methods of reducing blood transfusion in cardiac surgery: randomised controlled trial*. *BMJ* 2002; 324: 1299
8. Winton TL, Charrette EJ, Salerno TA. *The cell saver during cardiac surgery: does it save?* *Ann.Thorac.Surg* 1982; 33: 379-81
9. Magovern JA, Sakert T, Benckart DH, Burkholder JA, Liebler GA, Magovern GJ, Sr., Magovern GJ, Jr.. *A model for predicting transfusion after coronary artery bypass grafting*. *Ann.Thorac.Surg* 1996; 61: 27-32
10. Moskowitz DM, Klein JJ, Shander A, Cousineau KM, Goldweit RS, Bodian C, Perelman SI, Kang H, Fink DA, Rothman HC, Ergin MA. *Predictors of transfusion requirements for cardiac surgical procedures at a blood conservation center*. *Ann.Thorac.Surg* 2004; 77: 626-34
11. Scott BH, Seifert FC, Glass PS, Grimson R. *Blood use in patients undergoing coronary artery bypass surgery: impact of cardiopulmonary bypass pump, hematocrit, gender, age, and body weight*. *Anesth Analg* 2003; 97: 958-63
12. Shapira OM, Aldea GS, Treanor PR, Chartrand RM, DeAndrade KM, Lazar HL, Shemin RJ. *Reduction of allogeneic blood transfusions after open heart operations by lowering cardiopulmonary bypass prime volume*. *Ann.Thorac.Surg* 1998; 65: 724-30
13. Diem K, Lentner C. *Documenta Geigy: Scientific tables, 7th Edition*. 1970, pp 554-5.

## Appendix:

The expression that was used to predict  $Hct_{CPB}$  was obtained by reasoning that haemodilution is the main cause of the decreased haematocrit on commencing CPB. We therefore used the dilution equation whereby:

$$C_2 = (V_1 \cdot C_1) / V_2 \quad \text{(Equation 1A)}$$

Where  $C_2$  = final haemoglobin concentration (during CPB);  $V_1$  = initial volume (i.e. the patient's pre-operative blood volume);  $C_1$  = pre-operative haemoglobin concentration and  $V_2$  = final volume (blood volume + CPB prime + retained intravenously-administered fluids).

$V_1$  (in ml) was calculated by multiplying patient weight (in kg) by a factor of 70<sup>13</sup>. To convert pre-operative haemoglobin concentration ([Hb]) to haematocrit, we used the definition of the mean corpuscular haemoglobin concentration (MCHC), whereby haematocrit = 100\*[Hb] / MCHC. If patients mean MCHC is assumed to be 34.1%<sup>13</sup>, then Hct is given by [Hb]\*2.93. The expression to calculate a patient's predicted  $Hct_{CPB}$  is therefore:

$$Hct_{pred} = \frac{(\text{Weight} * 70 * [\text{Hb}] * 2.93)}{((\text{weight} * 70) + D)} \quad \text{Equation 2A}$$

where  $Hct_{pred}$  is the predicted  $Hct_{CPB}$ .  
The expression simplifies to:

$$Hct_{pred} = \frac{\text{Weight} * [\text{Hb}] * 205.3}{((\text{weight} * 70) + D)} \quad \text{Equation 3A}$$

The parameter D represents the total amount of fluid by which the patient's blood is diluted, i.e. CPB-prime plus retained intravenously-administered fluids (Note that urine output was not taken into consideration). D was unknown, as it is impossible to predict individual patients' fluid requirements and what proportion of intravenously administered crystalloid fluids remain in the intravascular compartment. We therefore surmised that the parameter, D could be estimated from the study group data by utilizing their measured  $Hct_{CPB}$ . To obtain parameter D, equation 2A was fitted to the measured  $Hct_{CPB}$  values using nonlinear regression. The curve-fit converged at a value of 4008 ml (standard error 173 ml). In order to make the calculation more convenient and the formula easier to remember, the parameters were rounded-off so that the equation that was used to predict the  $Hct_{CPB}$  was:

$$Hct_{pred} = \frac{\text{Weight} * [\text{Hb}] * 200}{((\text{weight} * 70) + 4000)} \quad \text{Equation 4A /1}$$

In the analysis of the predictive performances of equation 3A, there were no significant differences when the exact or the rounded parameters were used.