

# Prediction of Underfilling Defect in Aluminium Profile Extrusion Based on ALE Simulation

Ivan Kniazkin<sup>1,a\*</sup>

<sup>1</sup>Micas Simulations Limited, Temple Court, 107 Oxford Road, Oxford, OX4 2ER, U.K.

<sup>a</sup>ivankniazkin@gmail.com; kniazkin@qform3d.com

**Keywords:** profile extrusion; underfilling; simulation; defect; QForm; ALE approach; quality; FEM, aluminium

**Abstract.** The paper presents a detailed analysis of metal flow inside the extrusion dies and demonstrates the investigation of the formation of underfilling defects. The stress state in the defect zones has been analyzed by means of simulation based on the Eulerian approach. Based on this, it was found that the mean stress (hydrostatic pressure) is not the only parameter that has to be placed into the criterion to get reliable results. The author proposes a new dimensionless underfilling criterion adapted for Eulerian mesh. It is based on analysis of simulation results obtained by QForm Extrusion FEM software and practical experiments for different types of profiles. This criterion has been approved, and critical values have been obtained using a number of industrial projects from different areas of application.

## Introduction

Currently, in the aluminium industry, there is a high demand for a wide range of extruded profiles of different complexity: from solid bars to sophisticated hollow shapes for the automotive, aerospace, railway, and other industries. Complex shape extrusion dies are to be designed in a short time to cover practical needs. In this case, decisions are mostly based on the die designer's experience, making the design process more like an art rather than a science. That is why now, to minimize the risks, the numerical simulation of the extrusion process using the finite element method [1] becomes an indispensable stage within the general workflow of the tool and technology design.

Several different kinds of defects may appear during the industrial production of extruded profiles. The description of these defects and practical suggestions on how to avoid them were published in several works [2-5]. Additionally, the specific defects such as streaking lines [6-8], insufficient welding quality [9-13], back-end defect [14-16], charge weld propagation [16-19], surface speed cracking [20, 21] defects related to microstructure [22, 23] etc. have been investigated in more details using numerical simulations and industrial trials.

Meanwhile, one more defect that regularly appears in practice is underfilling (Fig. 1). It looks like holes or voids mostly in massive areas of the profile. In general, this defect can happen in extrusion through porthole tools with excessive support of mandrel cores or when an inappropriate shape of so-called fake mandrel core is used that has no bearings connected to it. A scheme of the defect formation is in Fig. 1. Here a predefective zone (pink) can be distinguished where the conditions of underfilling defect formation are fulfilled only partially, so the flow through these zones does not lead to a void. Red colour schematically represents the void.

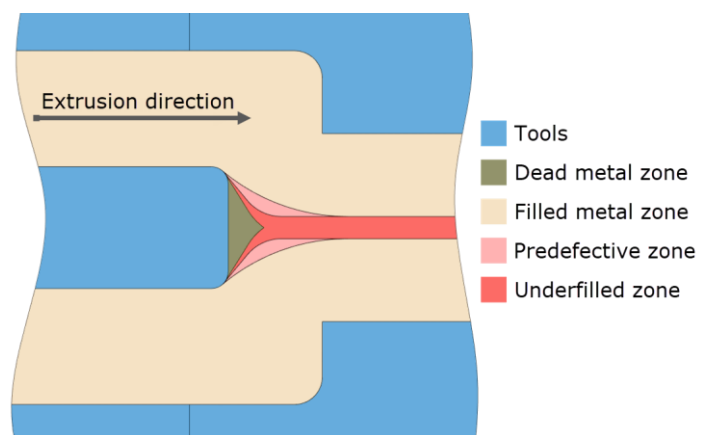

Fig. 1. Graphical representation of the underfilling defect

Unlike the other extrusion defects listed above, the investigation of the underfilling defect using numerical simulation has not been properly done. This paper aims to find the way to predict this kind of defects in extruded profiles using the numerical simulation of extrusion.

### Two Approaches to Material Flow Description

There are two ways to describe the deformed material motion that may be used in numerical simulation, i.e., Lagrangian and Eulerian. Principally both of them provide a comprehensive description of a continuum motion but have certain specifics when implemented in numerical simulation. One of such specifics is a visualization of a material flow. That is why this paper is focused on differences that affect the detection of the underfilling defect but without mathematical details, which are comprehensively described by several other authors [24-26].

**Basics of Lagrangian approach.** The Lagrangian approach is the most commonly and effectively used for finite element simulation of metal forming processes. This approach uses a movable mesh where each new position of nodes of finite elements is defined using velocity distribution calculated for a given time step. At each time increment, local boundary conditions may change due to contact development between deformed material and tools. It means that the metal flow is dynamically animated together with the mesh motion (Fig. 2).

One of the disadvantages of this method for the simulation of three-dimensional extrusion processes is the necessity of an incremental approach [26]. In this case, the continuous process is solved step-by-step from the initial billet configuration to a certain quasi-steady extrusion stage. The use of the incremental approach causes the distortion of finite elements, resulting in the accumulation of calculation inaccuracies and requires high mesh density in bearing zones that lead to significant simulation time. Thus, this approach is not widely used for the simulation of extrusion processes in industrial conditions since it cannot achieve the required accuracy within on time delivery (OTD) limits.

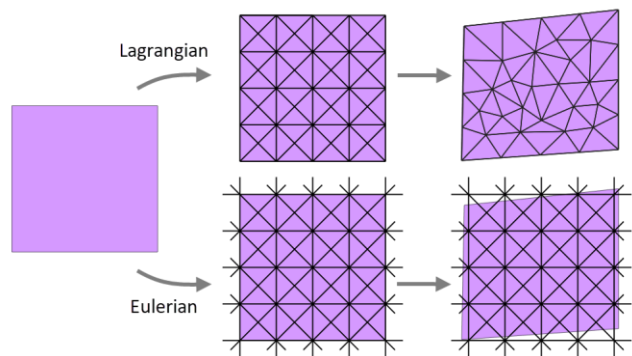

Fig. 2. Comparison of Lagrangian and Eulerian meshes

**Basics of Eulerian approach.** Unlike the Lagrangian approach, in the case of the Eulerian approach, the "flow-through" is simulated using a stationary mesh with certain initially defined boundary conditions. The boundary of the mesh is predefined based on the tool cavities, including the die orifice, and constrain the space where the metal can flow. Such an approach realized in QForm FEM software allows making the mesh flexibly adapted, providing fine mesh, especially in the profile near the bearings. This significantly impacts the accuracy of metal flow calculation, making it possible to consider small angles of bearing inclination on the calibrating surface of the tool.

On the other hand, the presence of Eulerian mesh inside tool cavities means that tool ports, chambers and profile sections are initially filled by finite elements (Fig 2). Therefore, it is not possible to distinguish an underfilling defect as voids in an extrudate. Nevertheless, since the Eulerian approach is the most effective for the processes where the deformation zone is stationary, this approach is predominantly used to simulate extrusion processes in industrial conditions [27].

**Other Eulerian mesh-based approaches.** There are several modified methods such as Arbitrary Lagrangian-Eulerian (ALE), multi-material ALE (MMALE), Coupled Eulerian-Lagrangian (CEL), etc., that combine Lagrangian and Eulerian approaches, partially taking advantages and eliminating disadvantages of both basic formulations. Regardless of the difference between them, in application to simulation of the extrusion processes, the common fact is that the stationary mesh is always used to define metal flow conditions inside the tool cavities. Therefore, the creation of a criterion that

makes it possible to predict the underfilling defect using Eulerian mesh is a relevant research challenge.

### Derivation of underfilling criterion

In extrusion, the stress inside the cavities before entering the bearing zone of the die set is a triaxial compression. The compression decreases along the extrusion direction as the metal approaches the bearings. It means that the material flows through the die set with a negative mean stress ( $\sigma_m < 0$ ) everywhere except the bearings zone. It is better to use the triaxiality  $\sigma_m/\sigma_s$  that is the ratio of mean stress to the flow stress in order to operate with dimensionless values. Since the Von Mises yield criterion is used and  $\bar{\sigma} = \sigma_s$ , where  $\bar{\sigma}$  is effective stress.

Therefore, it can be assumed that the triaxiality parameter can be used for the assessment of an underfilling defect, namely for the zones where the mean stress is over zero along the flow paths of the points. Another assumption is based on the idea that the underfilling is not formed instantly once the mean stress over zero is detected, but over a certain period of time. Thereby, to assess an underfilling, the triaxiality parameter should be accumulated over time in the zones where mean stress is over zero:

$$TR = \int_0^t \frac{\sigma_m^+}{\sigma_s} dt, \quad (1)$$

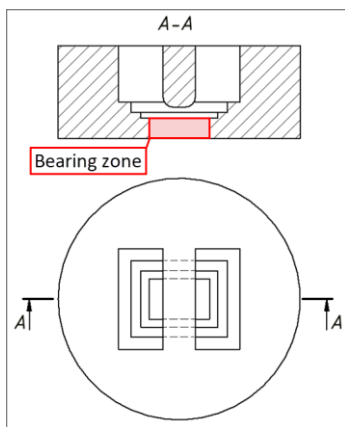

Fig. 3. Tool design with evident underfilling defect

Here  $\sigma_m^+$  – mean stress above zero,  $dt$  – time increment.

Since criterion (1) has the dimension of time, it can be additionally assumed that there is some critical time ( $t_{critical}$ ) that the metal spends inside the die set with the mean stress above zero ( $\sigma_m > 0$ ) upon which a defect is formed:

$$TR = \int_0^t \frac{\sigma_m^+}{\sigma_s} dt > t_{critical} \quad (2)$$

It is worth noting that any summation inside the tool cavities before reaching the bearings, in the regions where mean stress is over zero, is only possible by the use of the Eulerian approach. In reality, there will be no metal in the underfilled regions, therefore any values obtained by such integration are pseudo-values, the only meaning of which is to predict a defect when using the Eulerian approach.

To consider the proposed hypothesis, a specially prepared project with an evident underfilling defect was simulated (Fig. 3). It can be clearly seen that summation of the triaxiality on time according to proposed equations (1) and (2) does not allow unique identification of the defective zone. Additionally, the edge parts of the profile are marked improperly (Fig. 4). To analyze the reasons of this behaviour, two indicative points have been investigated: 1 – a point located in the corner of the profile, where an underfilling defect commonly does not occur; 2 – the point where an underfilling defect is reliably formed.

For point 1, the accumulation of the main fraction of plastic strain occurs before the metal enters the bearings, where an increase in deformation is practically not observed. At the same time, for point 2, a significant part of the accumulation of plastic

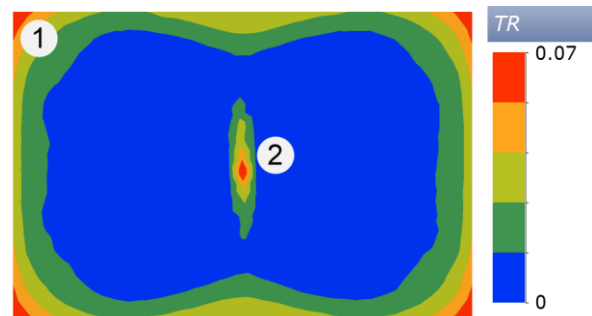

Fig. 4. Profile section with TR value (1) calculated for the design with evident underfilling defect

strain (or pseudo-strain) occurs in the zone of positive mean stresses:  $\sigma_m > 0$  (Fig. 5). Consequently, the ratio of the value of the accumulated strain in the zone of positive stresses to the total accumulated strain is significantly different for points 1 and 2 (Table 1).

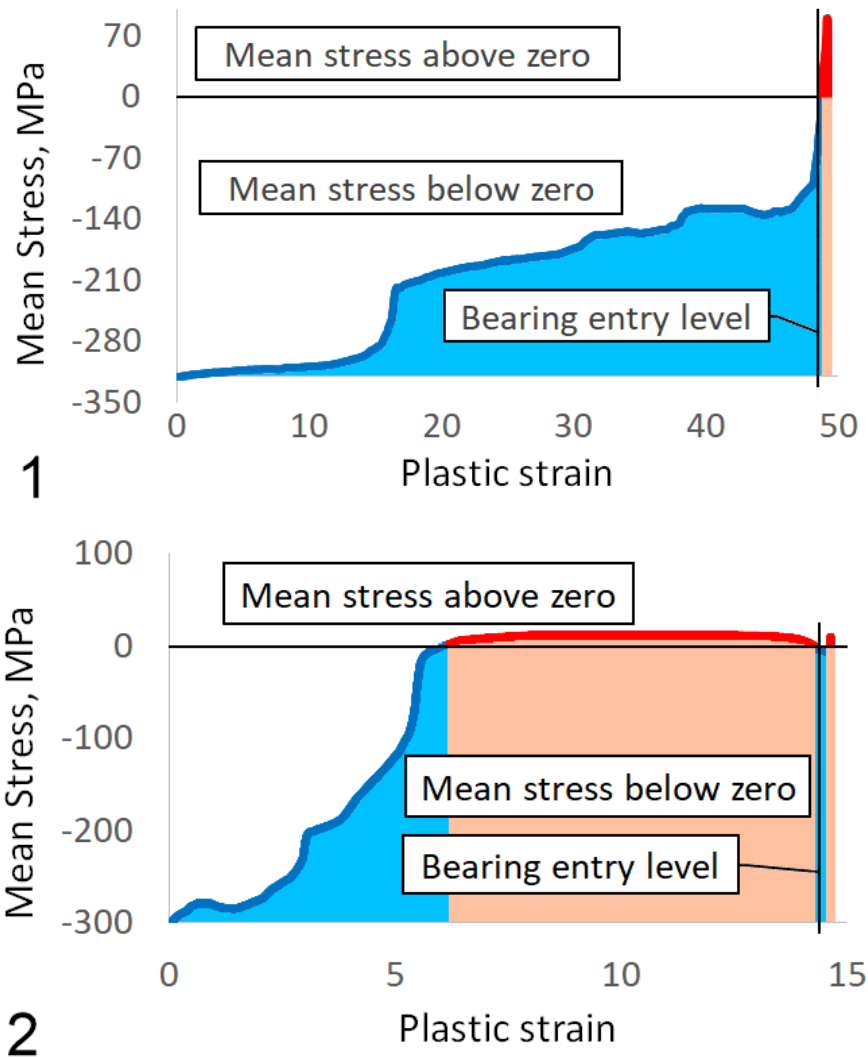

Fig. 5. Dependence of mean stress on plastic strain for points 1 and 2

Based on the obtained results, the proposed criterion has been transformed taking into account the mentioned ratio:

$$U = \frac{\varepsilon_p^+}{\varepsilon_p}, \quad (3)$$

Where  $\varepsilon_p$  – total accumulated plastic strain along path of the point,  $\varepsilon_p^+ = f(\sigma_m^+/\sigma_s, \dot{\varepsilon}, t)$  – plastic strain (pseudo-strain) accumulated in the zones where  $\sigma_m > 0$ .

The physical meaning of this criterion (3) is as follows: an underfilling defect is formed when the strain value accumulated under mean stress above zero  $\varepsilon_p^+$  is equal to or greater than a threshold fraction ( $k_\varepsilon$ ) of the total accumulated plastic strain ( $\varepsilon_p$ ).

$$U = \frac{\varepsilon_p^+}{\varepsilon_p} \geq k_\varepsilon \quad (4)$$

Table 1. Strain values under mean stress above zero and their fraction of the total accumulated plastic strain for points 1 and 2 along flow traces

$N_0$	Strain accumulated under mean stress above zero	Ratio of strain accumulated under mean stress above zero on total plastic strain
1	0.48	0.98%
2	8.21	56.11%

From where, normalizing by the threshold value, the final form of the criterion can be written as follows:

$$U_n = \frac{1}{k_\varepsilon} \cdot \frac{\varepsilon_p^+}{\varepsilon_p} \geq 1 \quad (5)$$

Based on the presented results, the critical fraction of the total accumulated plastic strain ( $k_\varepsilon$ ) was assumed to be equal to 3% of the total accumulated plastic strain for 6xxx series alloys, that allows to uniquely highlight the defect area (Fig. 6). This assumption was also made taking into account a number of industrial cases considered in comparison with simulation results (some of which are presented further in the chapter dedicated to industrial validation of the model). It means that values of the criterion (5) below 1 indicate zones free of defect. On the other hand, the zones with values close to 1 within some range, might be considered as predefective zones defining the respective flow areas (where the conditions of underfilling formation are fulfilled only partially) and marking the possible «thin» places of the design.

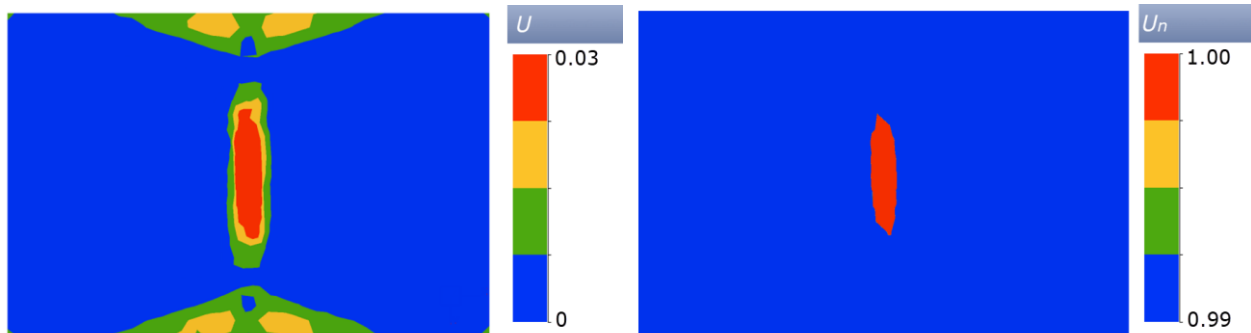

Fig. 6. Profile section with  $U$  (4) and  $U_n$  (5) fields calculated for the design with evident underfilling defect

It is worth noting that according to Fig. 5, it might seem that the summation of strain inside the bearing zone is excessive and leads to the accumulation of inaccuracies in the zones near the bearings. But practically it is not so, since in some industrial cases like multi-port (MP) or micro-multi-port profile extrusion (MMP), the accumulation of perceptible plastic strain may occur inside the bearing zone of Eulerian mesh (Fig. 7). It happens because the feeding volume of the central walls of the profile are generally designed to be relatively small in order to prevent high axial deflection of the tool. Therefore, using Eulerian approach, the impact of flow conditions near the bearings on the formation of the underfilling defect is quite sensitive to the specifics of the strain state of the metal passing through them, and that is why it has to be taken into account.

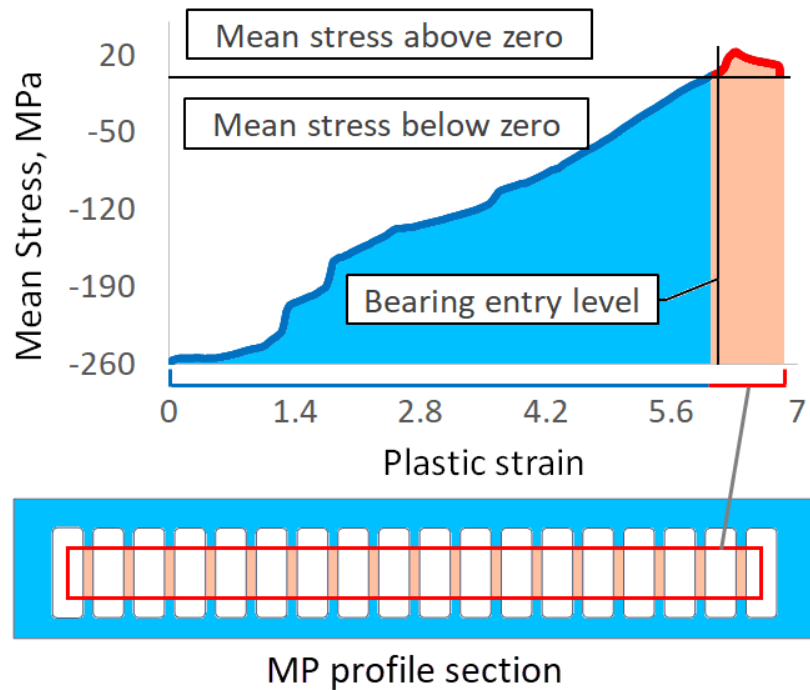

Fig. 7. Dependence of mean stress on plastic strain for points at the highlighted area

### Industrial Validation of the Model

To verify whether the proposed criterion of underfilling formation allows for a qualitative assessment of designed tools, a number of industrial cases with a wide range of defect propagation have been analyzed (Fig. 8).

The red colour of the underfilling distribution in simulation should be considered as an absence of material that directly indicates the unsuitability of the assessed design. All the other distributions displayed in such places have to be considered as pseudo-results. The blue colour indicates the material without defect.

According to the results of industrial verification, and taking into account that all the presented tests were performed for 6xxx series aluminium alloys, the assumed threshold fracture of accumulated plastic strain has been accepted as a critical value, at least for this series. On the other hand, since it is assumed that the underfilling model remains the same regardless of the alloy to be extruded, the critical value for other alloys can be quite simply defined by means of simulation using the inverse method of determination of weight coefficients in the presence of a certain amount of experimental data. As it can be seen from Fig. 8, the locations of the voids in the real profiles are in good correspondence with the simulation prediction.

### Conclusions

As a summary, the presented research allows to draw the following key findings:

- In the case of the Eulerian approach, a positive mean stress in aluminium inside the tool set cavities, before the metal enters the bearings, determines the zones where the material does not flow during real extrusion
- Mean stress is not the only parameter that determines underfilling defect for the Eulerian approach

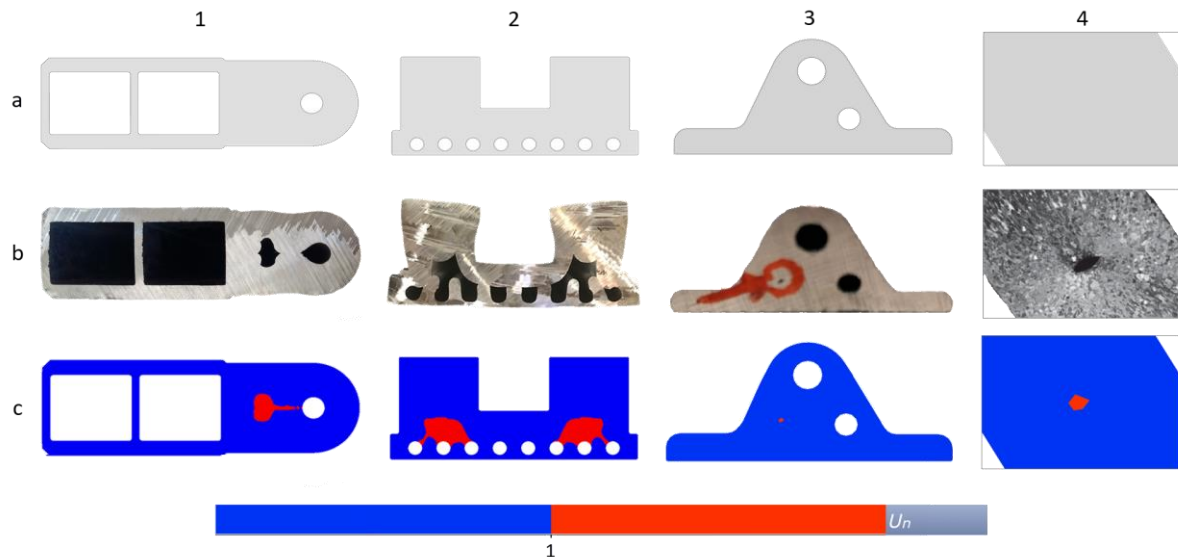

Fig. 8. Comparison of nominal profile shapes (a), real profile shapes (b) and simulation results (c) using underfilling criterion  $U_n$ . Experimental data provided by CO.M.P.ES. S.p.A., Brescia, Italy (2, 3) and taken from [28] (4).

- There is a critical value of plastic strain (pseudo-strain) accumulated in the zone of positive mean stresses in relation to the total accumulated strain, exceeding which leads to the formation of an underfilling defect
- For aluminum alloys of the 6xxx series, the critical fraction of the total accumulated plastic strain is 3%

## References

- [1] N. Biba, S. Stebunov, A. Vlasov, Application of QForm Program for Improvement of the Die Design and Profile Extrusion Technology, Proceedings of ET Seminar, Orlando, USA, 2008.
- [2] Sheppard, T. Extrusion of Aluminium Alloys, Kluwer Academic Publishers, Dordrecht, 1999.
- [3] S.Z. Qamar, A.F.M. Arif, A.K. Sheikh, Analysis of product defects in a typical aluminum extrusion facility, *Mater. Manuf. Process.*, 19 (2004) 391–405.
- [4] Ma X. Surface quality of aluminium extrusion products, Ph.D. thesis, Enschede: University of Twente, 2011
- [5] Neuhauser, F.M., Bachmann, G. & Hora, P. Surface defect classification and detection on extruded aluminum profiles using convolutional neural networks. *Int J Mater Form* 13, 591–603 (2020).
- [6] Babaniaris S., Beer A., Barnett M.R. The Influence of Process Parameters and Thermomechanical History on Streaking Defects in AA6060 Extrusions, in: Ratvik A. (Eds.), *Light Metals 2017*, The Minerals, Metals & Materials Series. Springer, Cham., 2017, pp. 371-377.
- [7] Babaniaris, S., Beer, A.G. & Barnett, M.R. Optical and Microstructural Origins of Thermomechanical Streaking Defects in Hot Extruded AA6060. *Metall Mater Trans A* 50, 5483-5493 (2019).
- [8] Y. Ma, X. Zhou, G.E. Thompson, J.-O. Nilsson, M. Gustavsson & A. Crispin. Origin of streaks on anodised aluminium alloy extrusions. *Transactions of the IMF*, 91:1, 11-16 (2013).
- [9] Plata M., Piwnik J. Theoretical and experimental analysis of seam weld formation in hot extrusion of aluminum alloys. 1 (2000), pp. 205-211.
- [10] L. Donati, L. Tomesani. The prediction of seam welds quality in aluminum extrusion. *Journal of Materials Processing Technology*. Volumes 153–154, 2004, Pages 366-373.

- [11] L. Donati, L. Tomesani. The effect of die design on the production and seam weld quality of extruded aluminum profiles. *Journal of Materials Processing Technology*. Volumes 164–165, 2005, Pages 1025-1031.
- [12] Schwane, M., Kloppenborg, T., Reeb, A., Ben Khalifa, N., Brosius, A., Weidenmann, K. A., & Tekkaya, A. E. Numerical Approach for the Evaluation of Seam Welding Criteria in Extrusion Processes. In *Key Engineering Materials*, (2012), (Vols. 504–506, pp. 517–522).
- [13] I. Kniazkin, A. Vlasov. Quality prediction of longitudinal seam welds in aluminium profile extrusion based on simulation. *Procedia Manuf.* 50, (2020), pp. 433-438.
- [14] H.S. Valberg, M. Lefstad, A.L.d. Moraes Costa. On the mechanism of formation of back-end defects in the extrusion process, *Procedia Manuf.*, 47 (2020) 245-252.
- [15] M. Negozio, R. Pelaccia, L. Donati, B. Reggiani, L. Tomesani, T. Pinter. FEM Validation of Front End and Back End Defects Evolution in AA6063 and AA6082 Aluminum Alloys Profiles. *Procedia Manuf.* 47, (2020), pp. 202-208.
- [16] Reggiani, B., Pinter, T. & Donati, L. Scrap assessment in direct extrusion. *Int. J. Adv. Manuf. Technol.* 107, 2635–2647 (2020).
- [17] B. Reggiani and L. Donati. Experimental, Numerical, and Analytical Investigations on the Charge Weld Evolution in Extruded Profiles, *Int. J. Adv. Manuf. Technol.*, 99 (2018) 1379-1387.
- [18] Negozio, M., Pelaccia, R., Donati, L. et al. Finite Element Model Prediction of Charge Weld Behaviour in AA6082 and AA6063 Extruded Profiles. *J. of Materi. Eng and Perform* 30, 4691–4699 (2021).
- [19] Reggiani, B., Segatori, A., Donati, L. et al. Prediction of charge welds in hollow profiles extrusion by FEM simulations and experimental validation. *Int J Adv Manuf. Technol* 69, 1855–1872 (2013).
- [20] Z. Peng & T. Sheppard. Study of surface cracking during extrusion of aluminium alloy AA 2014, *Materials Science and Technology*, 20:9, 1179-1191 (2004).
- [21] S. Ngernbamrung, Y. Suzuki, N. Takatsuji, K. Dohda. Investigation of surface cracking of hot-extruded AA7075 billet. *Procedia Manuf.* 15, (2018), pp. 217-224.
- [22] X. Xu, X. Ma, G. Zhao, Y. Wang, X.Chen. Effects of abnormal grain growth at longitudinal weld on the aging behavior and mechanical properties of 2196 AlCuLi alloy profile. *Materials & Design*. Volume 210, 2021.
- [23] Schikorra, M., Donati, L., Tomesani, L. et al. Microstructure analysis of aluminum extrusion: grain size distribution in AA6060, AA6082 and AA7075 alloys. *J Mech Sci Technol* 21, 1445 (2007).
- [24] J.L.F. Aymone, E. Bittencourt, G.J. Creus, Simulation of 3D metal-forming using an arbitrary Lagrangian–Eulerian finite element method, *Journal of Materials Processing Technology*, Vol. 110, Issue 2, 2001, Pages 218-232.
- [25] Skrzat, A. Application of coupled Eulerian-Lagrangian approach in metal forming simulations. *Zesz. Nauk. Politech. Rzesz. Mech.* 2012, 284, 25–35.
- [26] Danchenko V.M., Milenin A.A., Golovko O.M. “Production of profiles from aluminum alloys. Theory and technology”, 2002, Dnepropetrovsk, Ukraine, System technologies (In Russian).
- [27] Donati, L., Khalifa, N.B., Tomesani, L. et al. Comparison of different FEM code approaches in the simulation of the die deflection during aluminium extrusion, *Int. J. Mater. Form.* 3 (2010) 375-378.
- [28] Den Bakker, A. Weld seams in aluminium alloy extrusions: Microstructure and properties, Ph.D. thesis, Delft: University of Technology, 2016.