

CHAPTER 92

Preliminary Analysis of the Stability of Rubblemound Breakwater Crown Walls

by

David G. Hamilton¹ and Kevin R. Hall²

ABSTRACT

A series of two-dimensional hydraulic model tests was carried out to investigate the stability of rubblemound breakwater crown walls. The effect of seven design parameters on the minimum mass required for a crown wall to remain stable was studied: wave height, wave period, crown wall height, water level, front slope of the breakwater, position of the crown wall and length of stabilizing legs. Observations regarding the type of wave interaction, degree of overtopping, superstructure movement and overall hydraulic stability were studied. The coefficient of friction at the crown wall/breakwater interface was also measured. The crown wall superstructure was located on the crest of a conventional multi-layer breakwater and was subjected to both regular and irregular wave attack. Preliminary analysis of this data set is presented which shows trends established for each of the seven design parameters.

INTRODUCTION

Crown walls are designed, on a small scale, to provide pedestrian and vehicular access onto and along the crest of rubblemound breakwater structures. On a larger scale, crown walls support and protect pipelines and other services from the damaging forces of storm generated waves.

Crown walls are subjected to a complex set of forces including those resulting from direct wave impact and uplift pressure caused by the phreatic surface motion in the rubblemound. Since the physics of the hydrodynamic forces on crown walls is very complex, an accurate mathematical description of these forces, both spatially and temporally, along the front face and base of the crown wall is presently unattainable. Well designed hydraulic models are currently the only reliable design tool available, although these are subject to problems of scale effect due to the inability to obtain equality of Froude, Reynolds and Weber criteria. It is of paramount importance that the permeability of each layer is modelled correctly in order to minimize these scale effects.

1 Graduate Student, Department of Civil Engineering,
Queen's University, Kingston, Ontario, Canada K7L 3N6

2 Associate Professor of Civil Engineering,
Queen's University, Kingston, Ontario, Canada K7L 3N6

In one of the most comprehensive investigations of crown walls, Jensen (1983 and 1984) examined the forces on these structures by measuring the pressure distribution along the front face and base of the superstructure. A dimensionless empirical relationship was derived in order to predict the maximum horizontal wave force on the front face of a crown wall. Jensen's equation was calibrated to fit the model data using three sets of dimensionless coefficients which were valid for three specific crown wall configurations.

Bradbury et al. (1988) extended Jensen's work by modelling structures with different armour unit configurations fronting crown walls. The maximum horizontal force on the front face of the crown wall was measured for each of the crown wall/crest armour geometries using a system of strain gauges mounted inside a force table. By using an armour coefficient for a single wave climate, the authors extended Jensen's equation to six different crown wall/crest armour configurations. However, the authors point out that each of the two armour unit coefficients are only valid for a single random wave condition. They state that further studies are required to verify these armour unit coefficients over a wider range of incident wave conditions.

Although other studies of crown walls have been conducted, these two investigations are the most comprehensive. However, the results obtained from both of these studies could not be extrapolated with confidence to the range of breakwater/crown wall configurations of interest in this study.

This present study was undertaken in a two-dimensional wave flume at the Coastal Engineering Research Laboratory at Queen's University. The tests were developed to determine what influence seven design parameters had on the minimum mass for which a given crown wall configuration would remain stable: wave height, wave period, crown wall height, water level, front slope of the breakwater, position of the crown wall and length of stabilizing legs. Observations regarding the type of wave interaction, superstructure movement and overall hydraulic stability of the crown wall/breakwater were also studied. Finally, the hydraulic performance of each crown wall configuration was evaluated and classified as either an overtopping or a non-overtopping structure for a given design wave climate.

The testing programme consisted of 49 tests covering the range of breakwater/crown wall configurations and water levels presented in Table 1.

EXPERIMENTAL SETUP

All experiments were carried out in a 0.9-m wide wave flume with an overall length of 47 m and an overall depth of 1.8 m. Tests were conducted with three different still water levels; 0.800, 0.850 and 0.875 m above the flume bottom. Both regular and irregular wave attack was used. A minimum of twelve combinations of wave height and wave period were used for each crown wall/breakwater configuration, as shown in Table 2. For some tests, as many as eight wave heights (for each wave period) were tested in order to better define trends in the stability data.

TABLE 1
Test Summary

Test	F (mm)	H _{cw} (mm)	BW Front Slope	P _{cw}	L _{cw} (mm)	Wave Type
RC1C01, RC1A01	25	40	1:1.5	C and A	N/A	Reg
RC1C02, RC1A02	50	40	1:1.5	C and A	N/A	Reg
RC1C03, RC1A03	100	40	1:1.5	C and A	N/A	Reg
RC1C04, RC1A04	25	70	1:1.5	C and A	N/A	Reg
RC1C05, RC1A05	50	70	1:1.5	C and A	N/A	Reg
RC1C06, RC1A06	100	70	1:1.5	C and A	N/A	Reg
RC1C07, RC1A07	25	100	1:1.5	C and A	N/A	Reg
RC1C08, RC1A08	50	100	1:1.5	C and A	N/A	Reg
RC1C09, RC1A09	100	100	1:1.5	C and A	N/A	Reg
RC1C10, RC1A10	25	100	1:3	C and A	N/A	Reg
RC1C11, RC1A11	50	100	1:3	C and A	N/A	Reg
RC1C12, RC1A12	100	100	1:3	C and A	N/A	Reg
RC2C01	25	100	1:1.5	C	10	Reg
RC2C02	50	100	1:1.5	C	10	Reg
RC2C03	100	100	1:1.5	C	10	Reg
RC2C04	25	100	1:1.5	C	30	Reg
RC2C05	50	100	1:1.5	C	30	Reg
RC2C06	100	100	1:1.5	C	30	Reg
RC2C07	25	100	1:1.5	C	50	Reg
RC2C08	50	100	1:1.5	C	50	Reg
RC2C09	100	100	1:1.5	C	50	Reg
RC2C10	25	100	1:3	C	10	Reg
RC2C11	25	100	1:3	C	30	Reg
RC2C12	25	100	1:3	C	50	Reg
RC3C01, RC3A01	25	N/A	1:1.5	C and A	N/A	Reg
RC3C02, RC3A02	50	N/A	1:1.5	C and A	N/A	Reg
RC3C03, RC3A03	100	N/A	1:1.5	C and A	N/A	Reg
RC3C04, RC3A04	25	N/A	1:3	C and A	N/A	Reg
IC1C01*	25	40	1:1.5	C	N/A	Irr
IC1C04*	25	70	1:1.5	C	N/A	Irr
IC1C07*	25	100	1:1.5	C	N/A	Irr
IC1C08	50	100	1:1.5	C	N/A	Irr
IC1C09*	100	100	1:1.5	C	N/A	Irr

C = On Core, A = On Armour

*Only T = 1.75s

Ex. RC1C01 represents

R = Regular waves

C1 = Configuration 1 crown wall

C = Crown wall resting on Core layer.

01 = Test 1

The conventional multi-layer rubblemound breakwater consisted of a core layer (13-mm angular stone), a filter layer (40-mm angular stone) and an armour layer (two layers of 80-mm angular stone). Other characteristic properties are given in Table 3. All of the angular stone was assumed to have a specific gravity of 2.65.

Three types of crown walls were tested, as shown in Figure 1. Configuration 1 consisted of a vertical wall connected to a base plate. Crown wall heights of 40, 70 and 100 mm were tested. Configuration 2 was similar with the exception of an additional set of stabilizing legs penetrating the core layer. The objective of these legs was to increase the stability of the crown wall during wave attack. Three different pairs of stabilizing legs were constructed, with lengths of 10, 30 and 50 mm. Configuration 3 was used to simulate a walkway by removing the vertical crown wall and the stabilizing legs. Each structural member of the crown wall superstructure was fabricated using aluminum alloy having a specific gravity of 2.8.

The stability of the crown wall was tested in two positions. First, the crown wall was placed on top of the core at the breakwater crest, as shown in Figure 2a. It was assumed that for any future breakwater designs, the crown wall would be placed in this position. From a stability perspective, this was the ideal position since the crown wall is protected from direct wave impact forces during wave attack. As it was critical to isolate the horizontal resistance of the crown wall to frictional resistance, see Figure 2b, armour units were placed (seaward and landward of the structure) so that they added no additional stability to the crown wall.

In the second position, the crown wall was constructed on top of the armour layer along the breakwater crest (Figure 3). If crown walls could be designed to remain stable in this position, the armour units would not need to be removed to construct crown walls on existing breakwaters. However, installing the crown wall on top of the armour stone created two problems. First, it was difficult (if not impossible) to place the crown wall on top of the armour stones while maintaining the proper horizontal and vertical alignment along the breakwater crest. Secondly, the horizontal resistance created by friction between only a few armour stones and the base of the crown wall was considerably less than that found when the crown wall was constructed on the core of the breakwater. To resolve these two problems, a gravel bed was prepared along the crest of the breakwater by placing core material in the large voids between each armour stone. The crown wall was removed after completing each test and if any undermining or erosion had taken place, the gravel bed was reconstructed.

Preliminary studies were undertaken to determine the coefficient of friction at the breakwater/crown wall interface. A device was designed to enable the horizontal resistance of the crown wall to be measured over the range of crown wall mass which would be required during stability tests. Linear regression analysis resulted in a best fit line having a coefficient of friction, $\mu = 0.51$, as shown in Figure 4. This agrees with prototype estimates of $\mu = 0.50$ to 0.55 (Jensen, 1984), and $\mu = 0.60$ Goda (1985) between concrete superstructures and quarry stone.

The minimum wall and base thickness of prototype crown walls was assumed to be 0.20 m, as this thickness would provide adequate coverage for reinforcing steel within a crown wall. As this model was designed at a geometric scale of approximately 1:20, the minimum crown wall mass used throughout this study was approximately 6.5 kg, depending on the crown wall configuration.

TABLE 2
Incident wave conditions for testing

Segment No.	T (s)	H (mm)	H/L _o	$\xi = \tan\theta / [(H/L_o)^{1/2}]$	
				Slope 1:1.5	Slope 1:3
1	1.25	120	0.049	2.65	1.45
2	1.25	150	0.061	2.37	1.30
3	1.25	180	0.074	2.16	1.18
4	1.25	200	0.082	2.05	1.12
5	1.75	100	0.021	4.07	2.22
6	1.75	160	0.033	3.21	1.76
7	1.75	210	0.044	2.81	1.54
8	1.75	270	0.056	2.47	1.35
9	2.25	100	0.013	5.23	2.86
10	2.25	140	0.018	4.42	2.42
11	2.25	190	0.024	3.79	2.08
12	2.25	230	0.029	3.45	1.89

TABLE 3
Summary of characteristic material properties

Material type	Nominal Diameter			Mass		
	Dmin (mm)	D50 (mm)	Dmax (mm)	Mmin (g)	M50 (g)	Mmax (g)
13 mm crushed gravel	9	13	30	1	3	35
39 mm crushed gravel	37	39	42	70	85	100
80 mm armour stone	70	80	90	500	680	1000

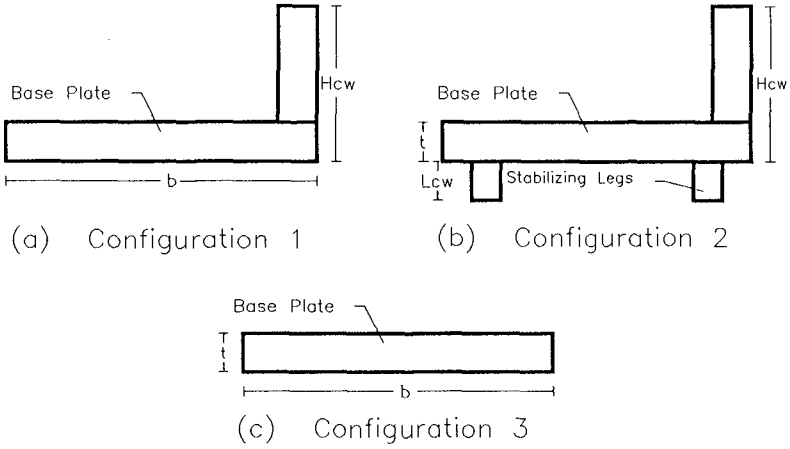

Figure 1 Configuration of 3 Crown Wall Test Sections

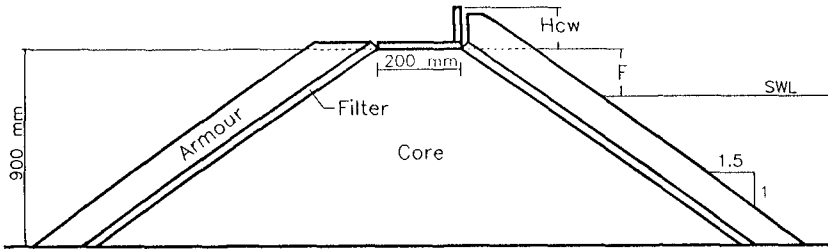

Figure 2a Crown Wall resting on Armour Layer

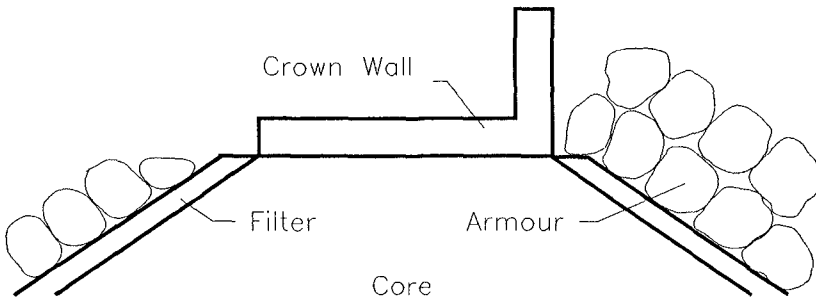

Figure 2b Placement of Armour Stone Adjacent to Crown Wall

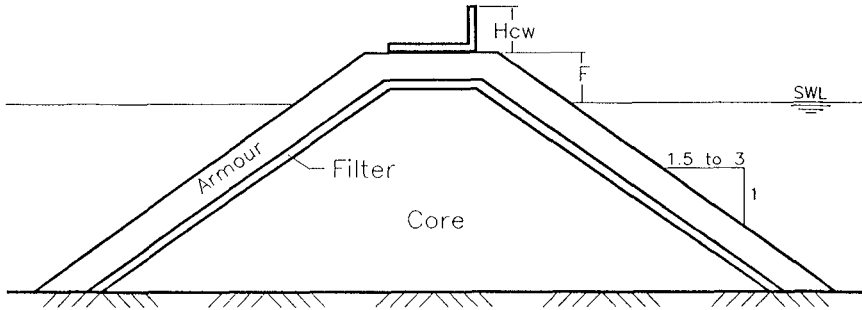

Figure 3 Crown Wall Resting on Armour Layer

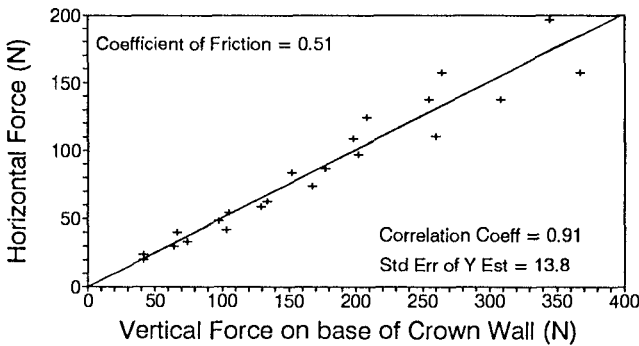

Figure 4 Coefficient of Friction at Crown Wall-Breakwater Interface

DETERMINATION OF MINIMUM STABLE MASS

Minimum stable mass (MSM) was defined as the minimum mass for which a given crown wall/breakwater configuration would remain stable while being subjected to certain design wave conditions. The MSM of a crown wall represented the point of limiting equilibrium between stable and unstable conditions. At this minimum mass, the crown wall could withstand a variety of complex and interactive forces resulting from direct wave impact, uplift pressure resulting from phreatic surface motion in the breakwater and forces associated with overtopping.

Results obtained from tests using Type 1 and 3 crown walls (Figure 1a and c) were classified into one of three categories; stable, unstable and minor displacements. The failure mode for each of these tests was found to be a sliding failure. A test was categorized as stable if the crown wall remained stationary during exposure to wave attack. In some tests vibrations of the crown wall were observed, although any resultant displacement would exclude such a result from

this category. Minor displacement test results were defined as tests in which the crown wall was displaced less than 10 mm during wave attack. This category included instances in which the crown wall would undergo a parallel slide, or alternatively, displacements of only one end of the crown wall. Test results in which the crown wall was displaced more than 10 mm were defined as an unstable. This category included three types of displacements of the crown wall. The two most common types of failures were displacements of the crown wall parallel to its original position or displacements of only one end of the crown wall. In some instances a catastrophic failure occurred in which the crown wall was forced over the landward side of the breakwater.

Test results for the Type 2 crown wall (Figure 1b) were classified as either stable or unstable. The mode of failure in each of these tests was found to be a quasi-overturning failure. The minor displacement failure category was not used for Type 2 crown wall tests since any measurable overturning of the crown wall was considered to be a failure.

Figure 5 is an example of typical test results from one test in the data set. The curve shown in the figure passes through the data points representing the minimum stable mass of the crown wall at different wave heights. This curve represents a reasonably accurate relationship between the mass of a crown wall and the incident wave height at the point of limiting equilibrium between stable and unstable conditions.

Test results presented later in this paper are based on the minimum stable mass of the crown wall. This will allow comparisons between different test results to be readily made.

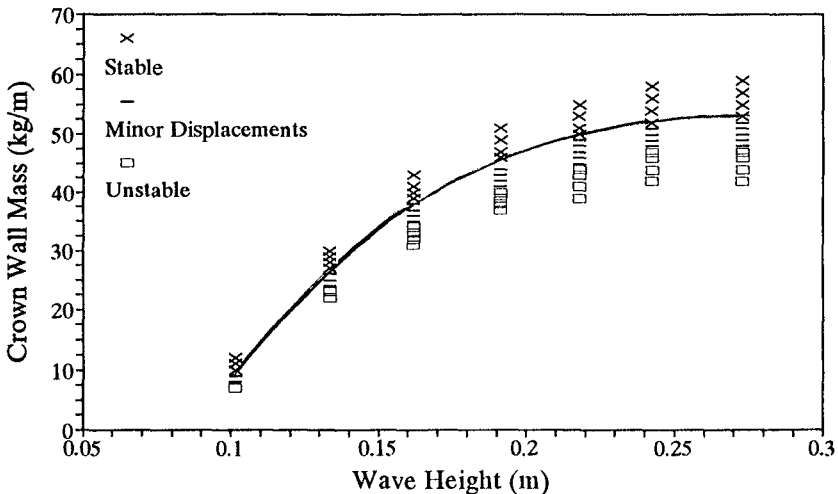

$T = 1.75s, F = 0.025m, H_{cw} = 0.100m, \text{Slope } 1:1.5, \text{On Core}$

Figure 5 Variability of Crown Wall Stability

PRELIMINARY RESULTS

Wave height

The following trends between incident wave height and minimum stable mass (MSM) were observed during preliminary analysis of the data set. Figure 6 shows typical test results.

Each test commenced with small waves and gradually the incident wave height was increased. When relatively small waves attacked the structure, the wave runup and internal phreatic surface would continue to fluctuate although no forces would be applied to either the base or the front face of the crown wall. Under these conditions a unit increase in the incident wave height had no influence on the stability of the crown wall.

Once the incident wave height was large enough for the wave runup and internal phreatic surface to reach the base elevation of the crown wall, a linear relationship between MSM and wave height was found. This agrees with results published by Jensen (1983 and 1984) and Bradbury et al (1988). This linear relationship continued until the waves were large enough to induce a significant amount of greenwater overtopping. At this point, the rate of increase of the MSM continued to decrease and a horizontal asymptote was approached.

Height of crown wall

Figure 7 shows an example of the minimum mass required to ensure stability of a crown wall for three different crown wall heights. All of the available data consistently demonstrated that the stability of a crown wall increased with decreasing crown wall height. Three other conclusions were also worth noting. First, when the wave height was only 0.10 m, all three crown walls were found to have the same minimum stable mass (MSM). This was expected because for wave heights less than 0.10 m, no water overtopped the lowest crown wall (0.04 m high). Secondly, results of tests having a crown wall height of 0.040 m showed that the MSM remained constant once the incident wave height exceeded approximately 0.20 m. As stated earlier, this threshold wave height was directly related to the initiation of green water overtopping. Thirdly, the threshold wave height was found to increase with increasing height of the crown wall. This was also expected; a larger wave height was required to overtop a higher crown wall.

Eight tests were conducted using the Type 3 crown wall. All results demonstrated that this structure was substantially more stable than Configuration 1 and 2, under the same conditions. During most tests this crown wall was stable at the minimum mass. However, when the crown wall was on the armour layer and was subjected to very large waves, the stability of the structure increased with increasing wave period, decreasing water level and decreasing front slope steepness.

Freeboard

The stability of each breakwater/crown wall configuration was evaluated for three different values of freeboard; 25, 50 and 100 mm. Tests consistently showed that the stability of a crown wall increased as the water level decreased.

Wave period

The influence of wave period on the stability of a crown wall was tested for wave periods of 1.25, 1.75 and 2.25s. In general, the stability of a crown wall increased with decreasing wave period.

Breakwater front slope

The front slope of the breakwater was also found to influence the stability of a crown wall. Two front slopes were tested, $\text{Cot}\theta = 1.5$ and 3.0 , as these are the two extreme slopes usually found on prototype breakwaters. The data showed that, in general, the stability of a crown wall increased as the steepness of the front slope decreased.

Position of crown wall

The influence of crown wall position was evaluated by conducting one set of tests with the crown wall resting on the core at the breakwater crest and another set with the crown wall resting on the armour layer. Figure 8 shows typical results from both sets of tests. The data demonstrated that for all wave conditions and breakwater/crown wall configurations, a crown wall was substantially more stable when resting on the core at the breakwater crest. These results seem reasonable when the following points are considered. First, when the crown wall rests on the core, the armour stones fronting the crown wall dissipate a significant amount of wave energy. Secondly, the armour units fronting the crown wall protect the superstructure from direct wave impact when the crown wall is resting on the core of the breakwater. Thirdly, the maximum elevation of the phreatic surface is lower when the crown wall is positioned on the core as compared with tests conducted with the crown wall on the armour layer, due to the difference in permeability of the two layers.

Stabilizing legs

The influence of stabilizing legs on the stability of a crown wall is illustrated in Figure 9. Incorporating stabilizing legs into the design of a crown wall significantly increased the overall stability of the superstructure. However, the 30 and 50 mm stabilizing legs were no more effective at increasing the stability of a crown wall than 10 mm legs.

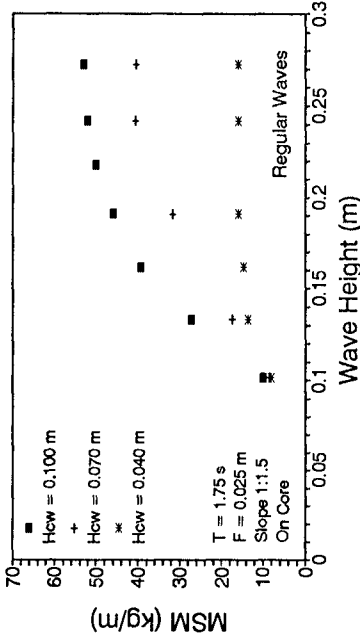

Figure 7 Influence of Crown Wall Height

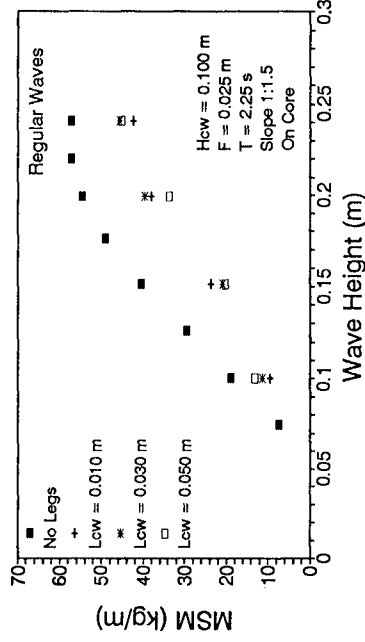

Figure 9 Influence of Stabilizing Legs

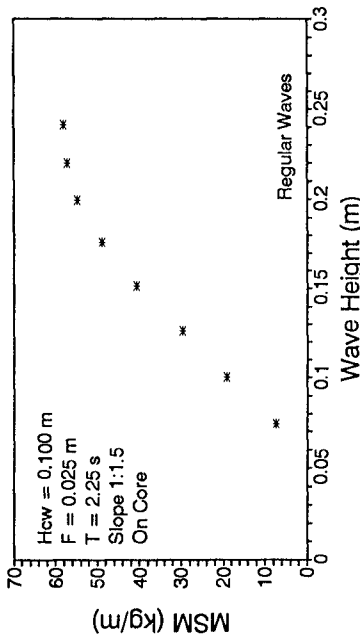

Figure 6 Influence of Incident Wave Height

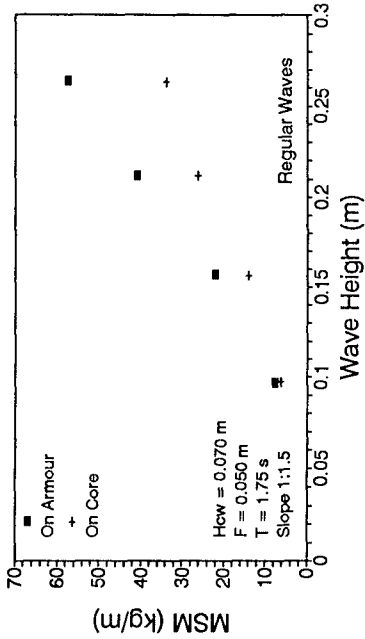

Figure 8 Influence of Crown Wall Position

Test results indicate that the use of stabilizing legs transformed what would otherwise be a purely sliding failure into a quasi-overturning failure. This change in failure mode occurred since less force was required to drag the seaward leg of the crown wall out of the core material (quasi-overturning failure) compared to the force required to cause a purely sliding failure.

IRREGULAR WAVE TESTS

All of the results discussed above were obtained using regular sinusoidal waves. Five of these regular wave tests were repeated using irregular wave trains (see Table 1) to determine how the stability results of each set of tests could be correlated. A JONSWAP wave spectrum was synthesized using the National Research Council of Canada GEDAP laboratory control package.

Irregular wave test results were plotted as a function of regular wave test results, presented in Figure 10. Each data point indicates the irregular and regular wave height at which a specific crown wall configuration became unstable; the minimum stable mass. Assuming a irregular wave Rayleigh distribution, the irregular wave height, H_i , was defined using the equation, $H_i = k\sigma$. It was determined that $H_i = 5.1\sigma$ gave the best correlation between the two sets of data. This represents the average wave height of the highest 10% of the waves, H_{10} , in the irregular wave train. Therefore, tests undertaken using irregular waves reproduced the same results as regular wave tests if H_{10} of the irregular wave train was equal to the wave height of the regular wave train.

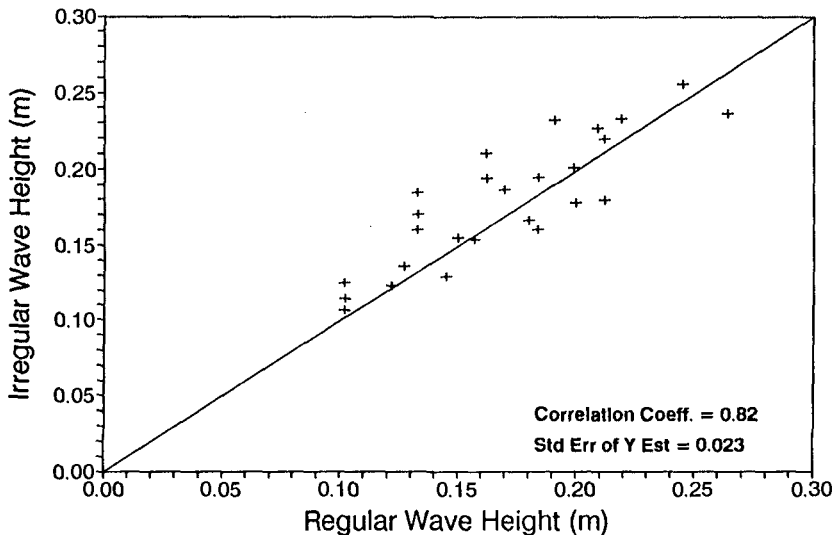

Figure 10 Irregular vs. Regular Wave Stability Tests
(Irregular wave train defined by $H_i = 5.1\sigma$)

CONCLUSIONS

Tests were conducted to evaluate the influence of seven design parameters on the hydraulic stability of crown walls. By determining the mass of each crown wall configuration at the point of limiting equilibrium between stable and unstable conditions (minimum stable mass), the following general trends have been established.

(1) During exposure to moderate wave climates, the magnitude of the wave forces on each crown wall configuration were found to be proportional to wave height. However, once the waves were large enough to induce greenwater overtopping, the wave induced forces approached a maximum. The data set showed that for each breakwater/crown wall configuration an upper limit exists, independent of wave climate, at which the destabilizing wave forces remain constant.

(2) The stability of each breakwater/crown wall configuration was found to increase with decreasing crown wall height, decreasing water level, decreasing wave period and decreasing front slope steepness.

(3) The forces exerted on a crown wall resting on the core of a breakwater were substantially less than those tests conducted with the crown wall resting on the armour layer. This demonstrated that the armour units fronting a crown wall dissipated a significant amount of wave energy and protected the superstructure from direct wave impact. It also demonstrated that decreasing the permeability of the material below the crown wall (core vs. armour material) significantly decreased the maximum elevation of the internal phreatic surface, and thereby reduced the uplift pressures.

(4) Stabilizing legs substantially increased the stability of each crown wall configuration. Short legs were found to be equally as effective as longer stabilizing legs.

(5) The coefficient of friction below the model crown wall was found to be similar to prototype estimates of the friction coefficient between a reinforced concrete superstructure and quarry stone.

(6) Irregular wave tests, simulating a JONSWAP spectrum, reproduced the same crown wall stability as regular wave tests, if H_{T0} of the irregular wave train was equal to the wave height of the regular wave train.

ACKNOWLEDGEMENTS

The authors would like to express their appreciation to Public Works Canada, Marine H.Q. and Small Craft Harbours, Department of Fisheries and Oceans, Canada for providing financial support for this study.

LIST OF SYMBOLS

D_{50}	= Median diameter of stone gradation
F	= Freeboard
H	= Wave height of regular wave train
H_{cw}	= Height of the crown wall
H_1	= Irregular wave height
L_{cw}	= Length of crown wall stabilizing legs
L_o	= Deepwater wave length
MSM	= Minimum stable mass of crown wall
M_{50}	= Median mass of stone gradation
P_{cw}	= Position of crown wall
t	= Thickness of crown wall base
T	= Wave period of regular wave train
ξ	= Surf similarity parameter

REFERENCES

Bradbury, A P., Allsop N W H. and R V. Stevens (1988). Hydraulic Performance of Breakwater Crown Walls. Report No. SR 146, Hydraulics Research Wallingford, March 1988.

Goda, Y. (1985). *Random Seas and Design of Maritime Structures*. University of Tokyo Press, Tokyo, Japan.

Jensen, O.J. (1983). Breakwater Superstructures. Coastal Structures '83, Arlington, Virginia, U.S.A., March 1983.

Jensen, O J. (1984). *A Monograph on Rubblemound Breakwaters*. Danish Hydraulic Institute, Horsholm, Denmark.