

Received 19 November 2018; revised 27 January 2019, 7 March 2019, and 18 March 2019; accepted 18 March 2019. Date of publication 26 March 2019; date of current version 23 August 2019. The review of this paper was arranged by Editor N. Sugii.

Digital Object Identifier 10.1109/JEDS.2019.2907299

Process Dependence of Soft Errors Induced by Alpha Particles, Heavy Ions, and High Energy Neutrons on Flip Flops in FDSOI

MITSUNORI EBARA^{1b}, KODAI YAMADA^{1b}, KENTARO KOJIMA, JUN FURUTA^{1b},
AND KAZUTOSHI KOBAYASHI^{1b} (Member, IEEE)

Graduate School of Science and Technology, Kyoto Institute of Technology, Kyoto 606-8585, Japan

CORRESPONDING AUTHOR: M. EBARA (e-mail: mebara@vlsi.es.kit.ac.jp)

This work was supported by the Program on Open Innovation Platform with Enterprises, Research Institute and Academia (OPERA) from Japan Science and Technology Agency (JST).

ABSTRACT Soft-error tolerance depending on threshold voltage of transistors was evaluated by α -particle, heavy-ion, and neutron irradiation. Three chips were fabricated, one embeds low-threshold general-purpose (GP) transistors and the others embed high-threshold low-power (LP) transistors in a 65 nm fully depleted silicon on insulator (FDSOI) process. There were a few errors on LPDFFs (DFFs with LP transistors). Error probability (EP) of LPDFFs was 99.88% smaller than that of GPDFFs (DFFs with GP transistors) by α particles. Average cross sections (CSs) of LPDFFs by heavy ions were 50% smaller than those of GPDFFs. Average soft-error rates (SERs) of LPDFFs by neutrons were 68% smaller than those of GPDFFs. 3-D device simulations revealed that CSs of the LP and GP transistors are changed by fitting methods using the work function of the gate material and doping concentration of the substrate under the BOX layer. The difference is due to the number of carriers in diffusion and silicon thickness of the raised layer above drain and source terminals.

INDEX TERMS Soft error, α particle, neutron, heavy ion, FDSOI, flip flop, TCAD simulations, threshold voltage.

I. INTRODUCTION

Reliability issues have become a significant concern with technology downscaling such as temporal failures and aging degradation [1]. Soft errors are one of temporal failures that flip stored values in storage cells caused by α particles, neutrons and heavy ions. α particle is a radioactive particle originated from a package material. Neutrons are generated by nuclear reactions between cosmic rays and the atmosphere air. In outer space, heavy ions are dominant to cause failures. A flipped storage value can be recovered by rebooting or rewriting. However, it is a serious issue especially for critical devices dealing with human life or social infrastructures. In device level, the fully-depleted silicon on insulator (FDSOI) structure can suppress soft errors. FDSOI has 50x - 100x higher tolerance for soft errors than bulk because the buried-oxide (BOX) layer prevents charge from being collected from substrate [2].

The threshold voltage of thin BOX FDSOI transistors is generally controlled by the work function of the gate material and doping concentration of the substrate under the BOX layer [3].

Semiconductor chips for low power must reduce leakage current. Low-power operation is mandatory for numerously-distributed Internet of Things (IoTs) driven by battery. It is hard to reboot hang-up devices manually. Thus it is important to prolong operation time of IoT devices by increasing reliability.

We evaluated soft-error tolerance of several chips including low-threshold general-purpose (GP) and high-threshold low-power (LP) transistors in a 65 nm thin BOX FDSOI.

This paper is based on a paper entitled “Threshold Dependence of Soft-Errors induced by α particles and Heavy Ions on Flip Flops in a 65 nm Thin BOX FDSOI” presented

TABLE 1. Normalized EP and CS in a 28 nm bulk process [4].

FF	V_{th}	EP	CS				
			O	Ne	Ar	Cu	Xe
DFF	standard	1	1	1	1	1	1
	low	1.04	0.94	1.00	1.14	1.12	0.95
	high	1.03	1.06	0.85	1.07	0.96	1.00

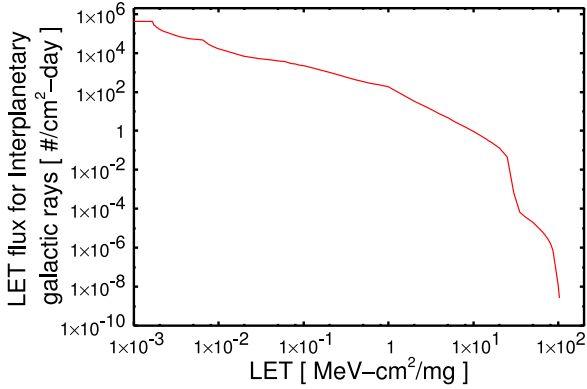

FIGURE 1. LET distribution of heavy ions in outer space [6].

at the 2018 IEEE S3S Conference. This paper has been supplemented by experimental results from spallation neutron irradiation and 3D device simulation results to reproduce heavy-ion irradiation.

Section II explains related works. Section III explains experimental results of fabricated chips including GP and LP transistors by α particle, heavy-ion and neutron irradiation. We explain simulation results in Section IV. Section V discusses inconsistency between measurement and simulation results. We conclude this paper in Section VI.

II. RELATED WORKS

Reference [4] evaluates soft-error tolerance of flip flops (FFs) with low, standard and high threshold transistors of a 28 nm bulk process. Table 1 shows the normalized error probability (EP) by α particles and cross section (CS) by O, Ne, Ar, Cu, and Xe irradiation. EP is calculated using Eq. (1). CS is equal to an area of upsets when a particle passes a storage cell [5]. Equation (2) shows how to calculate CS.

$$EP = \frac{N_{error}}{N_{FF}} \quad (1)$$

$$CS [cm^2/bit] = \frac{N_{error}}{N_{ion} \times N_{FF}} \quad (2)$$

N_{error} is the total number of errors by neutrons or heavy ions. N_{ion} is fluence that is the number of heavy ions per cm^2 . N_{FF} is the number of FFs. The linear energy transfer (LET) is the amount of energy that an ionizing particle transfers to the material traversed per unit distance. Figure 1 shows the existence probability of heavy ions in outer space [6]. The number of particles with over 40 MeV-cm²/mg is much less than that with less than 40 MeV-cm²/mg in outer space [6]. Table 1 are the measurement results by heavy-ion irradiation. The irradiated ions are O, Ne, Ar, Cu and Xe with LET of 2.2, 3.5, 9.7, 21.2 and 58.8 MeV-cm²/mg respectively.

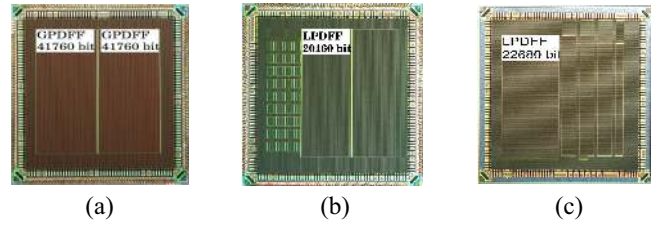

FIGURE 2. Fabricated chip micrographs including GP DFFs and LP DFFs. (a) Chip in GP. (b) Chip in LP. (c) Chip in LP.

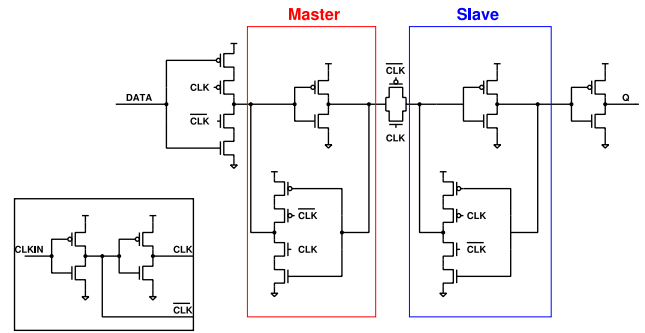

FIGURE 3. DFF structure.

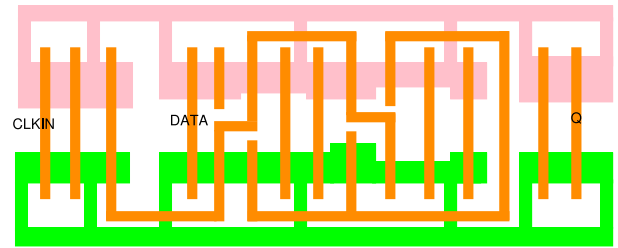

FIGURE 4. Simplified layout of DFF.

As a result, the soft-error rates of them were within 15% difference.

In the bulk process, the main cause of soft errors is the charge collection to drain by drift and funneling from substrate. It is independent or weakly dependent on threshold voltage. However, in the FDSOI process generated carriers in substrate cannot go to drain. Transistor characteristics such as threshold voltage, doping concentration and transistor structures may affect soft-error resilience.

III. EXPERIMENTAL RESULTS

A. EXPERIMENTAL SETUP

Three chips were fabricated in the 65 nm thin BOX FDSOI process with 12 nm SOI and 10 nm BOX layers in order to evaluate their soft-error tolerance [7]. Figure 2 show the chip micrographs that contain 83,520 bit GP DFFs (DFFs with GP transistors), 20,160 bit LP DFFs (DFFs with LP transistors), and 22,680 bit LP DFFs respectively. Figures 3 and 4 show the structure and the simplified layout of the standard DFF embedded in the three chips. We evaluated soft-error tolerance of chip (a) and (b) by α -particle and heavy-ion irradiation. Soft-error tolerance of chip (a) and (c) were also evaluated by neutron irradiation. Figure 5 shows the

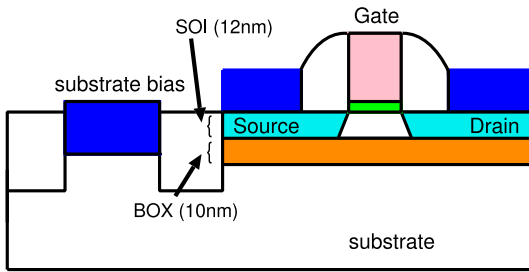

FIGURE 5. Cross sectional view of Thin BOX FDSOI.

TABLE 2. LET, energy, fluence of heavy ions.

Ion	Ar	Kr
LET [MeV-cm ² /mg]	17.5	40.9
Energy [MeV]	107	230
Fluence on GP transistors [n/cm ²]	2.62 × 10 ⁶	2.44 × 10 ⁶
Fluence on LP transistors [n/cm ²]	2.75 × 10 ⁶	2.88 × 10 ⁶

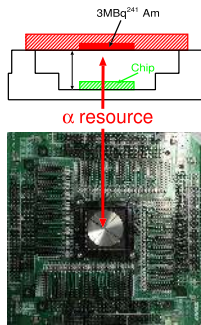

FIGURE 6. α -particle irradiation setup.

cross section of an NMOS transistor in the 65 nm thin-BOX FDSOI process [7].

α -particle irradiation tests were conducted using a 3 MBq ²⁴¹Am source. Each irradiation time was 300 sec. and irradiation was repeated for 10 times. Figure 6 shows an experimental setup of the α -particle irradiation test.

Heavy-ion irradiation tests were conducted by Ar and Kr ions at Takasaki Ion accelerators for Advanced Radiation Application (TIARA), Japan. Figure 7 shows the experimental setup of the heavy-ion irradiation tests. Device under tests (DUTs) are sealed in the chamber in order not to attenuate ion energy. Each irradiation time was 30 sec. and irradiation was repeated for 5 times. Table 2 shows LET, energy and average fluences of heavy ions.

Spallation neutron tests were conducted at the research center for nuclear physics (RCNP), Osaka University, Japan [8]. Figure 8 shows the experimental setup of neutron irradiation tests. Figure 9 shows the normalized neutron beam spectrum in comparison with the terrestrial neutron spectrum at the sea level in New York City (NYC). The average acceleration factor (AF) is 3.7 × 10⁸ in average compared with the sea level in NYC. In order to increase the number of upset FFs within a limited time, five stacked DUT boards with two test chips were exposed to the neutron beam. 10 chips were measured simultaneously. Each irradiation time was 300 sec.



FIGURE 7. Heavy-ion irradiation setup.



FIGURE 8. Spallation neutron irradiation setup.

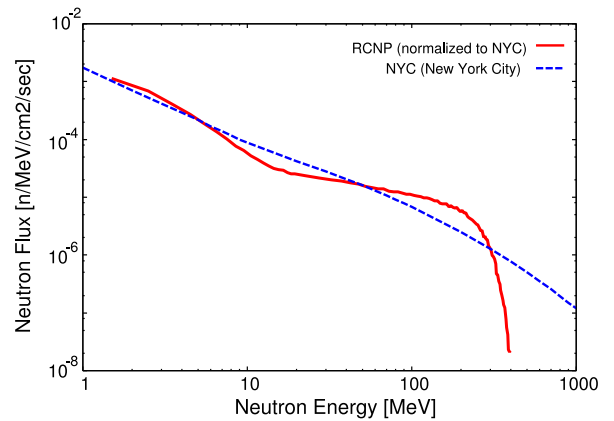

FIGURE 9. Normalized energy spectrum of spallation neutron beam at RCNP and neutron at the sea level of NYC.

and irradiation was repeated for 43 times. Soft-error rates (SERs) are calculated using Eq. (3).

$$SER \text{ [FIT/Mbit]} = \frac{N_{\text{error}} \times 10^9 \text{ h} \times 1024^2 \text{ bit}}{300 \text{ sec}/3600 \text{ sec} \times AF \times N_{\text{FF}}} \quad (3)$$

Irradiation was done at static conditions of (DATA, CLK) = (0,0), (0,1), (1,0), and (1,1). The supply voltage (V_{dd}) was 0.8 V by α -particle and heavy-ion irradiation. There was no error on LPDFs at V_{dd} of 0.8 V

TABLE 3. Average numbers of upsets and total numbers of FFs on GPDDFs and LPDDFs in the 65 nm thin-BOX FDSOI process by α particles.

chip (FF)	(DATA,CLK)				average
	(0,1)	(1,1)	(0,0)	(1,0)	
GP (a) (83520 bit)	1449.9	108.9	8.9	960.4	632.0
LP (b) (20160 bit)	0.1	0.1	0	0	0.05

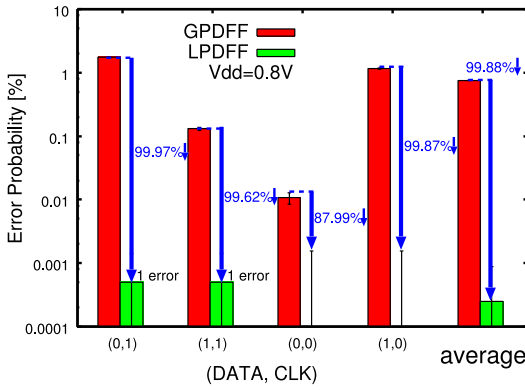

FIGURE 10. Error probability by α particle.

TABLE 4. Average numbers of upsets and total numbers of FFs on GPDDFs and LPDDFs in the 65 nm thin-BOX FDSOI process by Ar and Kr irradiation.

Ion	chip (FF)	(DATA,CLK)				average
		(0,1)	(1,1)	(0,0)	(1,0)	
Ar	GP (a) (83520 bit)	285.8	141.2	144.8	167.4	148.8
	LP (b) (20160 bit)	29.0	23.0	21.2	20.2	23.4
Kr	GP (a) (83520 bit)	473.0	156.4	162.4	271.6	265.9
	LP (b) (20160 bit)	55.0	32.4	28.2	27.2	35.7

by neutrons. In order to increase errors on LPDDFs, V_{dd} of GPDDF was 0.8 V and that of LPDDF was 0.6 V by neutron irradiation because the SERs increase as V_{dd} decreases [9]. Irradiation procedures were as follows.

- 1) Initialize serially-connected FFs by all 0 or all 1
- 2) Stabilize CLKIN to 0 or 1
- 3) Expose α particles, heavy ions or neutrons
- 4) Read out stored data of FFs
- 5) Count the number of upsets
- 6) Repeat 1) - 5) for four (DATA, CLK) conditions.

B. MEASUREMENT RESULTS

Table 3 shows the average numbers of upsets on GPDDFs and LPDDFs by α particles. The results of GPDDFs are quoted from [10]. Figure 10 shows the experimental results by α particles. The error bars are 95% confidence. LPDDFs are stronger against soft errors than GPDDFs at all static conditions. There are no error or a few errors on LPDDFs at all static conditions.

Table 4 shows the average numbers of upsets on GPDDFs and LPDDFs by Ar and Kr. Figures 11 and 12 show the experimental results by Ar and Kr with error bars of 95% confidence. LPDDFs are stronger against soft errors than GPDDFs at all static conditions. These results clearly reveal that the average CSs of LPDDFs are 50% and 54% smaller than those of GPDDFs by Ar and Kr respectively.

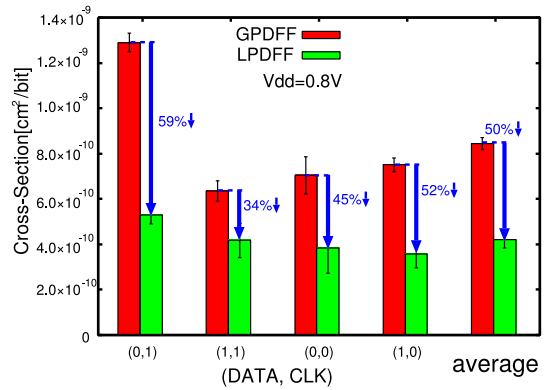

FIGURE 11. CSs by Ar irradiation.

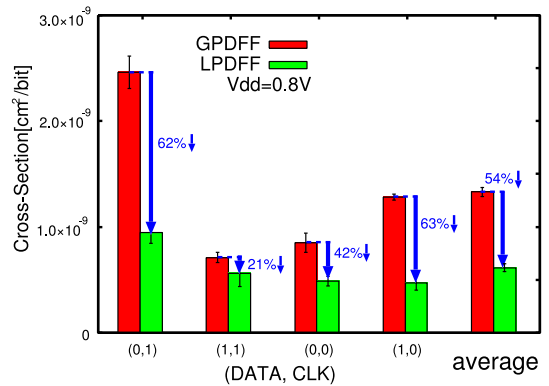

FIGURE 12. CSs by Kr irradiation.

TABLE 5. Average numbers of upsets and total numbers of FFs on GPDDFs and LPDDFs in the 65 nm thin-BOX FDSOI process by neutrons.

chip (FF) (V_{dd})	(DATA,CLK)				average
	(0,1)	(1,1)	(0,0)	(1,0)	
GP (83520 bit) (0.8 V)	1.95	0.4	0.65	1.65	1.16
LP (22680 bit) (0.6 V)	0.23	0.09	0.09	0.05	0.12

Table 5 and Fig. 13 show the average numbers of upsets and SER on GPDDFs and LPDDFs by neutrons. The error bars are 95% confidence. LPDDFs are stronger against soft errors than GPDDFs at all static conditions. The average SER of LPDDFs is 68% smaller than that of GPDDFs by neutron irradiation.

Results from α -particle, neutron and heavy-ion irradiation in the FDSOI process prove that LPDDFs are stronger against soft errors than GPDDFs.

IV. SIMULATION RESULTS

Table 6 shows normalized leakage current, threshold voltage and D-Q delay of FFs with the GP and LP transistors in the 65 nm thin BOX FDSOI process by circuit simulations. Figure 14 show the current-voltage (I_{ds} - V_{gs}) curve of the GP and LP transistors by circuit simulations. Leakage current of the LP transistors is 99% lower than that of the GP transistors. The LP transistors are suitable for IoT devices that are working periodically for a long battery life.

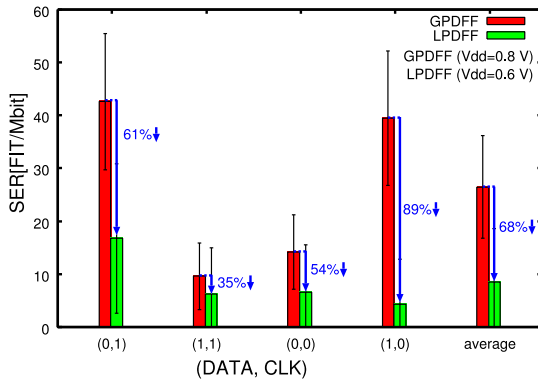

FIGURE 13. SERs by neutrons.

TABLE 6. Normalization of leakage current, threshold-voltage and D-Q delay of FF about GP and LP transistors.

	GP	LP
Threshold-Voltage	1	1.31
Leakage current	1	0.008
D-Q Delay of FF	1	1.64

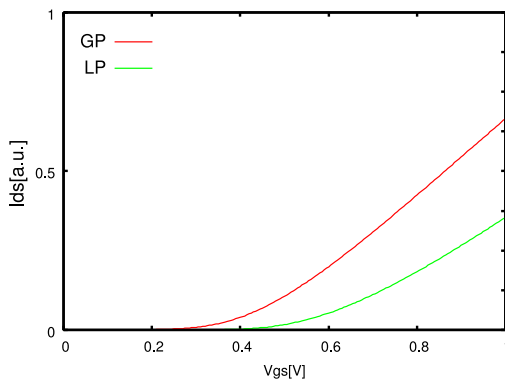

FIGURE 14. Ids-Vgs curve of GP and LP transistors on circuit simulations.

We carried out three dimensional TCAD simulations using Synopsys Sentaurus to evaluate radiation hardness of the latch in Fig. 16 with the GP and LP transistors constructed in the 65 nm FDSOI process. Figure 15 shows the Ids-Vgs curve of the GP and LP transistors on 3D device simulations. The Ids-Vgs curve of those transistors are adjusted to the models on circuit simulations by changing the work function of gate material and the doping concentration in substrate under the BOX layer. The channel doping is equal on both types of transistors. The doping concentration in the channel is influenced by ion implantation under the BOX layer in substrate. But the influence to transistor characteristics is limited. Thus we ignore the influence. Those adjusted the LP and GP transistors are used in TCAD simulations to evaluate CSs.

The structure of the latch is equivalent to that of the master latch of the standard DFF. Soft-error tolerance of the latch at V_{dd} of 0.8 V is evaluated. The initial values of n_0 , n_1 and CLK are set to 0, 1 and 1 respectively. The two NMOS

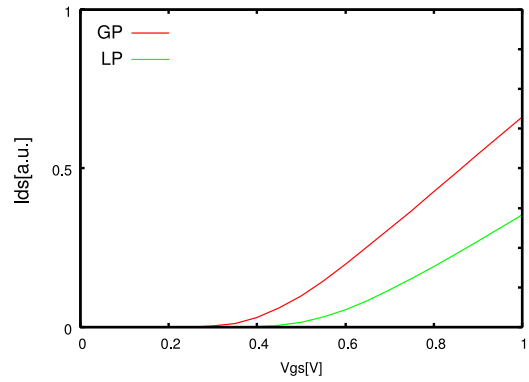

FIGURE 15. Ids-Vgs curve of GP and LP transistors on 3D device simulations. They are adjusted to the models on circuit simulations by changing the gate work function and the doping concentration under the BOX layer in substrate.

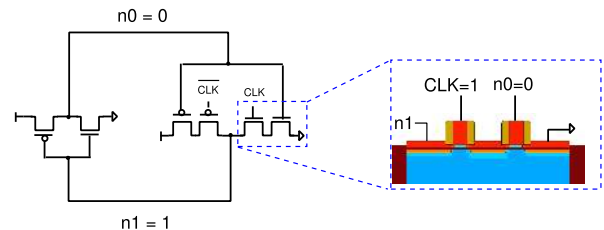

FIGURE 16. Latch on device and circuit simulations. NMOS of the tristate inverter is implemented by 3D device model. Other transistors are in a circuit level.

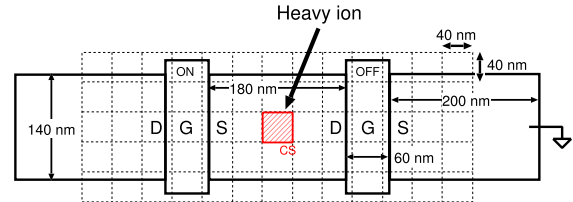

FIGURE 17. Top view of the 3D device model to evaluate CS on the tristate inverter.

transistors in the tristate inverter are implemented by 3D device models, while the other transistors are in the circuit level.

It has been revealed that NMOS transistors are weaker against soft errors than PMOS transistors mainly due to the difference of the mobility [11], [12]. We evaluated CS by hitting Ar ($LET = 17.5 \text{ MeV-cm}^2/\text{mg}$) and Kr ($LET = 40.9 \text{ MeV-cm}^2/\text{mg}$) vertically on NMOS region. Figure 17 shows a top view of the 3D device model to evaluate CS on the tristate inverter. The width of the tristate inverter and that in the fabricated chips are both 140 nm. A heavy ion hits every 40 nm grid. If a heavy ion makes the latch flip at a point, the $40 \text{ nm} \times 40 \text{ nm}$ square region around the hit point is included in CS.

In this simulation, the following physical conditions were validated: Mobility (Doping Dependence, High Field Saturation, Enormal), Fermi, Effective Intrinsic Density (Old Slotboom), Recombination (Shockley Read Hall, Auger).

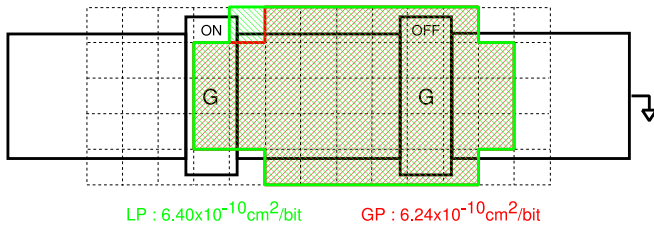

FIGURE 18. CS of GP and LP transistors in the tristate inverter by Ar ion irradiation.

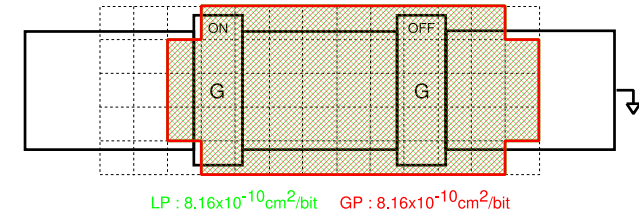

FIGURE 19. CS of GP and LP transistors in the tristate inverter by Kr ion irradiation.

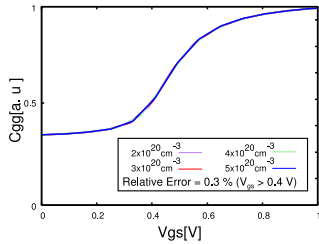

FIGURE 20. Cgg-Vgs curve of LP transistor by changing doping concentration in diffusion.

Figures 18 and 19 show the results of CS of the tristate inverter with the GP and LP transistors by Ar and Kr irradiation respectively. CS of the GP transistors is 3% smaller than that of the LP transistors by Ar ion. CSs with the LP and GP transistors are same by Kr ion. The GP transistors become stronger against soft errors than the LP transistors by 3D device simulations.

V. DISCUSSIONS

The measurement results were inconsistent to the simulation results. Our assumption is that it is due to the difference of the number of carriers in diffusion on GP and LP transistors. Equation (4) expresses auger recombination originated from electrons and holes. It is in proportion to the cube of the number of carriers.

$$R_{\text{auger}} = C_n n (np - n_i^2) + C_p p (np - n_i^2) \quad (4)$$

C_n and C_p are the constants of auger recombination. n and p are the electron and the hole density. n_i is the intrinsic carrier density.

The number of carriers collected in diffusion depends on doping concentration, which affects soft-error tolerance. The larger the rate of auger recombination is, the smaller CS becomes. Capacitance-voltage (Cgg-Vgs) and Ids-Vgs curves

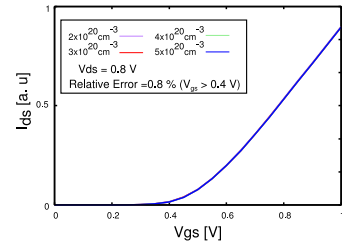
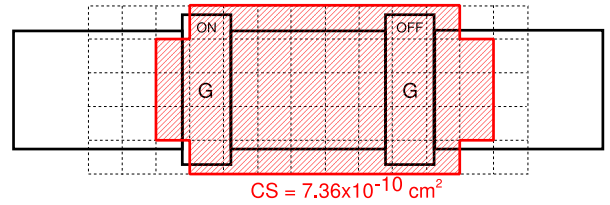
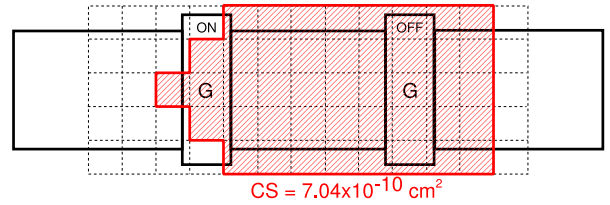

FIGURE 21. Ids-Vgs curve of LP transistor by changing doping concentration in diffusion.



(a)



(b)

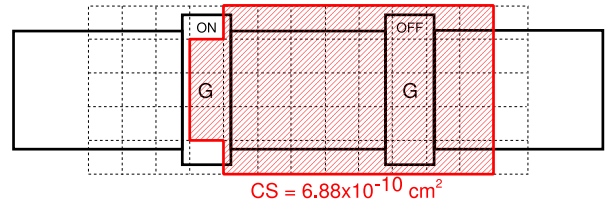

(c)

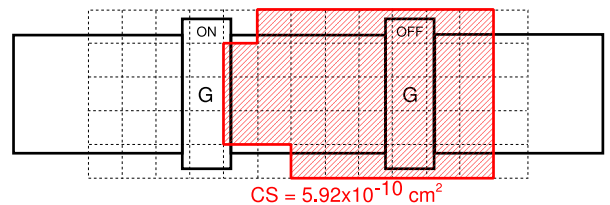

(d)

FIGURE 22. Transition of CS by changing doping concentration in diffusion. (a) $1 \times 10^{20} \text{ cm}^{-3}$ (b) $2 \times 10^{20} \text{ cm}^{-3}$ (c) $3 \times 10^{20} \text{ cm}^{-3}$ (d) $4 \times 10^{20} \text{ cm}^{-3}$.

of the transistor are drawn by TCAD simulations by changing doping concentration. From the results in Figs. 20 and 21, doping concentration in diffusion has a small impact on transistor performance. We carried out TCAD simulations to see how soft-error tolerance is influenced by doping concentration in diffusion. CS by Ar ion irradiation computed

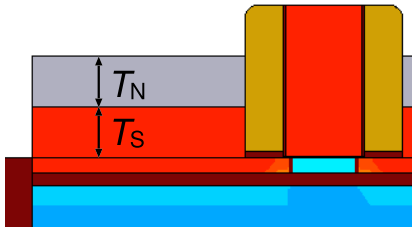

FIGURE 23. Structure of raised layer, definition of thickness of silicon (T_S) and thickness of nickel silicide (T_N) [13].

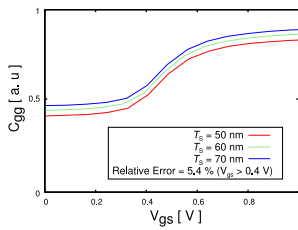

FIGURE 24. C_{gg} - V_{gs} curve of LP transistor by changing T_S in the raised layer.

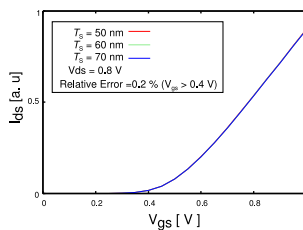

FIGURE 25. I_{ds} - V_{gs} curve of LP transistor by changing T_S in the raised layer.

as the same manner as in Section IV. Doping concentration is changed from $1 \times 10^{20} \text{ cm}^{-3}$ to $4 \times 10^{20} \text{ cm}^{-3}$.

Figure 22 show the results of CS when an Ar ion hits vertically on the NMOS region. CS is decreasing as increasing doping concentration. CS by $4 \times 10^{20} \text{ cm}^{-3}$ doping concentration in diffusion is 20% smaller than that by $1 \times 10^{20} \text{ cm}^{-3}$.

For further discussions, silicon thickness (T_S) in the raised layer on the GP and LP transistors are parameterized on device simulations in Fig. 23 [13]. CS is evaluated by changing T_S in the raised layer from 50 nm to 70 nm with the doping concentration of $1 \times 10^{20} \text{ cm}^{-3}$. From the results in Figs. 24 and 25 the raised layer has a small impact on transistor performance. CS at 50 nm T_S is 19.0% smaller than CS at 70 nm T_S .

Taking doping concentration in diffusion and T_S of the raised layer of LP and GP transistors into account, it is possible to reproduce the measurement results by device simulations.

VI. CONCLUSION

Soft-error tolerance of flip flops including low-threshold GP and high-threshold LP transistors in a 65 nm FDSOI

process was evaluated by α particle, neutron and heavy-ion irradiation and 3D device simulations. At 0.8 V supply voltage (V_{dd}), the error probability of LPDFFs was 99.88% smaller than that of GPDFFs by α particle. The average CSs of LPDFFs were 50% and 54% smaller than those of GPDFFs by Ar and Kr ions respectively. There was no error on LPDFFs at V_{dd} of 0.8 V by neutron irradiation. In order to increase the number of errors on LPDFFs, V_{dd} of GPDFFs was 0.8 V and that of LPDFFs was 0.6 V. The average SER of the LPDFFs is 68% smaller than those of GPDFFs by neutrons. The 3D simulations revealed CS of GP transistors is 3% smaller than that of LP transistors by Ar ion. CSs with the LP and GP transistors are same by Kr ion.

The cause of the inconsistency between the measurement and simulation results by Ar ion is originated from the number of carriers in diffusion, the substrate under BOX layer and silicon thickness (T_S) of the raised layer over drain and source terminals. CS on the tristate inverter with LP transistors of $4 \times 10^{20} \text{ cm}^{-3}$ doping concentration becomes 20% smaller than that of $1 \times 10^{20} \text{ cm}^{-3}$. CS at 50 nm T_S is 19.0% smaller than CS at 70 nm T_S .

Considering doping concentration in diffusion and silicon thickness of the raised layer of LP and GP transistors, the simulation results become closer to the measurement results.

LPDFF has smaller leakage current and is stronger against soft errors than GPDFF on FDSOI. FDSOI achieves both of low power and radiation hardness by using high-threshold transistors which are adequate to IoT devices operated by battery and hard to reboot.

ACKNOWLEDGMENT

The authors would like to thank to QST (National Institutes for Quantum and Radiological Science and Technology). The VLSI chip in this study has been fabricated in the chip fabrication program of VLSI Design and Education Center (VDEC) in collaboration with Renesas Electronics Corporation, Cadence Corporation, Synopsys Corporation and Mentor Graphics Corporation.

REFERENCES

- [1] R. Baumann, "The impact of technology scaling on soft error rate performance and limits to the efficacy of error correction," in *Dig. Int. Electron Devices Meeting*, Dec. 2002, pp. 329–332.
- [2] P. Roche, J.-L. Autran, G. Gasiot, and D. Munteanu, "Technology downscaling worsening radiation effects in bulk: SOI to the rescue," in *Proc. IEEE Int. Electron Devices Meeting*, Washington, DC, USA, Dec. 2013, pp. 31.1.1–31.1.4.
- [3] R. Tsuchiya *et al.*, "Silicon on thin BOX: A new paradigm of the CMOSFET for low-power high-performance application featuring wide-range back-bias control," in *IEEE Int. Electron Devices Meeting Tech. Dig. (IEDM)*, San Francisco, CA, USA, Dec. 2004, pp. 631–634.
- [4] N. Gaspard *et al.*, "Effect of threshold voltage implants on single-event error rates of d flip-flops in 28-nm bulk CMOS," in *Proc. IEEE Int. Rel. Phys. Symp. (IRPS)*, Anaheim, CA, USA, Apr. 2013, pp. SE.7.1–SE.7.3.
- [5] J. S. Kauppila *et al.*, "Utilizing device stacking for area efficient hardened SOI flip-flop designs," in *Proc. IEEE Int. Rel. Phys. Symp.*, Waikoloa, HI, USA, Jun. 2014, pp. SE.4.1–SE.4.7.

- [6] M. A. Xapsos, C. Stauffer, T. Jordan, J. L. Barth, and R. A. Mewaldt, "Model for cumulative solar heavy ion energy and linear energy transfer spectra," *IEEE Trans. Nucl. Sci.*, vol. 54, no. 6, pp. 1985–1989, Dec. 2007.
- [7] N. Sugii *et al.*, "Local V_{th} variability and scalability in silicon-on-thin-box (SOTB) CMOS with small random-dopant fluctuation," *IEEE Trans. Electron Devices*, vol. 57, no. 4, pp. 835–845, Apr. 2010.
- [8] C. W. Slayman, "Theoretical correlation of broad spectrum neutron sources for accelerated soft error testing," *IEEE Trans. Nucl. Sci.*, vol. 57, no. 6, pp. 3163–3168, Dec. 2010.
- [9] H. Maruoka, M. Hifumi, J. Furuta, and K. Kobayashi, "A non-redundant low-power flip flop with stacked transistors in a 65 nm thin BOX FDSOI process," in *Proc. 16th Eur. Conf. Radiat. Effects Compon. Syst. (RADECS)*, Sep. 2016, pp. 1–4.
- [10] K. Yamada, H. Maruoka, J. Furuta, and K. Kobayashi, "Radiation-hardened flip-flops with low-delay overhead using pMOS pass-transistors to suppress SET pulses in a 65-nm FDSOI process," *IEEE Trans. Nucl. Sci.*, vol. 65, no. 8, pp. 1814–1822, Aug. 2018.
- [11] K. Yamada, H. Maruoka, J. Furuta, and K. Kobayashi, "Sensitivity to soft errors of NMOS and PMOS transistors evaluated by latches with stacking structures in a 65 nm FDSOI process," in *Proc. IEEE Int. Rel. Phys. Symp. (IRPS)*, Burlingame, CA, USA, Mar. 2018, pp. 1–5.
- [12] P. Hazucha *et al.*, "Neutron soft error rate measurements in a 90-nm CMOS process and scaling trends in SRAM from 0.25- μ m to 90-nm generation," in *Proc. IEEE Int. Electron Devices Meeting*, Dec. 2003, pp. 21.5.1–21.5.4.
- [13] J. Furuta, K. Kojima, and K. Kobayashi, "Evaluation of heavy-ion-induced SEU cross sections of a 65 nm thin BOX FD-SOI flip-flops based on stacked inverter," in *Proc. RADECS*, Sep. 2018.



KENTARO KOJIMA was born in Shiga, Japan, in 1994. He received the B.E. degree in electronics and system engineering from the Kyoto Institute of Technology, Kyoto, Japan, in 2018.



JUN FURUTA was born in Gifu, Japan, in 1986. He received the B.E. degree and the M.E. and Ph.D. degrees in electrical and electronic engineering in informatics from Kyoto University, Kyoto, Japan, in 2009, 2011, and 2014, respectively. In 2014, he joined the Kyoto Institute of Technology as a specially appointed Assistant Professor, where he was then promoted to an Assistant Professor in 2017.



MITSUNORI EBARA was born in Osaka, Japan, in 1995. He received the B.E. degree in electronics and system engineering from the Kyoto Institute of Technology, Kyoto, Japan, in 2018, where he is currently pursuing the master's degree.



KODAI YAMADA was born in Aichi, Japan, in 1994. He received the B.E. and M.E. degrees in electronics and system engineering from the Kyoto Institute of Technology, Kyoto, Japan, in 2017 and 2019, respectively.



KAZUTOSHI KOBAYASHI (M'96) received the B.E., M.E., and Ph.D. degrees in electronic engineering from Kyoto University, Japan, in 1991, 1993, and 1999, respectively.

In 1993, he joined the Graduate School of Informatics, Kyoto University, as an Assistant Professor, where he was promoted to an Associate Professor and stayed in that position until 2009. During this time, he was also an Associate Professor of VLSI Design and Education Center with the University of Tokyo for two years. Since 2009, he has been a Professor of the Kyoto Institute of Technology. In the past he focused his research on reconfigurable architectures utilizing device variations. His current research interest is in improving the reliability (soft errors, bias temperature instability, and plasma induced damage) of current and future VLSIs. He has been researching on gate drivers for power transistors since 2013.

Dr. Kobayashi was a recipient of the IEICE Best Paper Award in 2009 and the IRPS Best Poster Award in 2013.