

# **Product **Work** Breakdown Structure**

U.S. DEPARTMENT OF COMMERCE

**Maritime Administration**

in cooperation with

**Todd Pacific Shipyards Corporation**

# Report Documentation Page

*Form Approved*  
*OMB No. 0704-0188*

Public reporting burden for the collection of information is estimated to average 1 hour per response, including the time for reviewing instructions, searching existing data sources, gathering and maintaining the data needed, and completing and reviewing the collection of information. Send comments regarding this burden estimate or any other aspect of this collection of information, including suggestions for reducing this burden, to Washington Headquarters Services, Directorate for Information Operations and Reports, 1215 Jefferson Davis Highway, Suite 1204, Arlington VA 22202-4302. Respondents should be aware that notwithstanding any other provision of law, no person shall be subject to a penalty for failing to comply with a collection of information if it does not display a currently valid OMB control number.

1. REPORT DATE <b>NOV 1980</b>	2. REPORT TYPE	3. DATES COVERED <b>00-00-1980 to 00-00-1980</b>			
4. TITLE AND SUBTITLE <b>Product Work Breakdown Structure</b>		5a. CONTRACT NUMBER			
		5b. GRANT NUMBER			
		5c. PROGRAM ELEMENT NUMBER			
6. AUTHOR(S)		5d. PROJECT NUMBER			
		5e. TASK NUMBER			
		5f. WORK UNIT NUMBER			
7. PERFORMING ORGANIZATION NAME(S) AND ADDRESS(ES) <b>Naval Surface Warfare Center CD, Code 2230 -Design Integration Tower, 9500 MacArthur Blvd Bldg 192 Room 128, Bethesda, MD, 20817-5700</b>		8. PERFORMING ORGANIZATION REPORT NUMBER			
9. SPONSORING/MONITORING AGENCY NAME(S) AND ADDRESS(ES)		10. SPONSOR/MONITOR'S ACRONYM(S)			
		11. SPONSOR/MONITOR'S REPORT NUMBER(S)			
12. DISTRIBUTION/AVAILABILITY STATEMENT <b>Approved for public release; distribution unlimited</b>					
13. SUPPLEMENTARY NOTES					
14. ABSTRACT					
15. SUBJECT TERMS					
16. SECURITY CLASSIFICATION OF:			17. LIMITATION OF ABSTRACT	18. NUMBER OF PAGES <b>89</b>	19a. NAME OF RESPONSIBLE PERSON
a. REPORT <b>unclassified</b>	b. ABSTRACT <b>unclassified</b>	c. THIS PAGE <b>unclassified</b>			

UMTRI

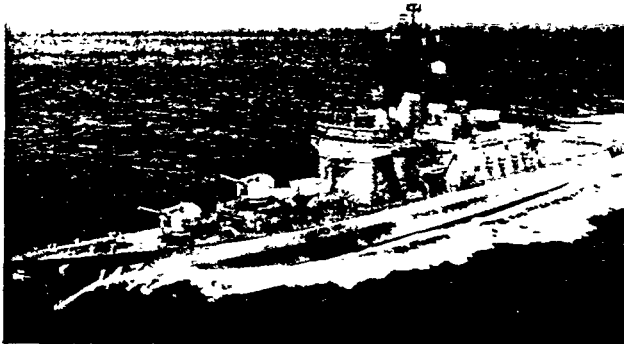
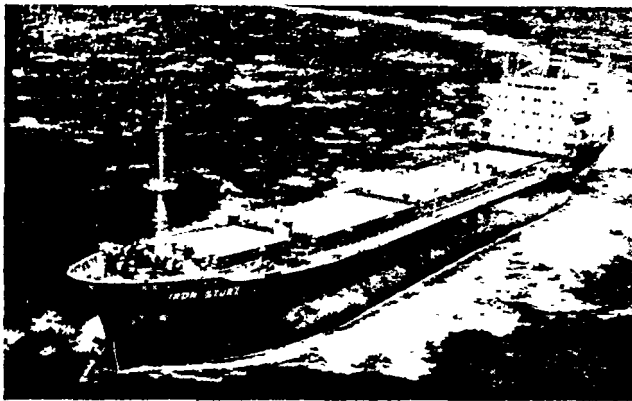
48811

## FOREWORD

The Product Work Breakdown Structure (PWBS) described herein is based upon that used by Ishikawajima-Harima Heavy industries Co., Ltd. (IHI) of Japan. It has been developed and refined during the construction of over 2,000 ships in the last two decades. Thus, PWBS is not just based on theory. It has been repeatedly proven in all IHI shipyards and in other shipyards in Asia, Europe and South America which have adopted IHI methods.

PWBS employs the logic of Group Technology (GT) which is a method for applying mass production techniques to a variety of products in widely varying quantities. As applied to ship construction, PWBS classifies components to be purchased, parts to be fabricated and planned subassemblies in order to achieve uniform and coordinated work flows. In shipbuilding, as in other industries, GT has yielded substantial benefits even when resources remained essentially unchanged.

The transition to PWBS has already begun in some U.S. shipyards. Implementation is difficult only because of human problems. PWBS features unprecedented integration of hull construction, outfitting and painting. Further, it features cost centers which exactly match a zone-oriented organization. Thus, it does not permit isolationist performers to claim credit without evaluating their impact on the work of others. Also, more so than ever before, PWBS puts "cross hairs" on the performances of shipbuilding managers and workers.



IRON STURT, a 22,000-deadweight ton multi-purpose cargo carrier, the 5,200-displacement ton helicopter destroyer SHIRANE (delivery March 1980) and the 484,000-deadweight ton tanker GLOBTIK TOKYO, not shown, were all constructed by IHI with the PWBS described herein.

## ACKNOWLEDGEMENTS

The author is Y. Okayama, Consulting Group Manager, IHI International Division.

The editor and contributing author is L.D. Chirillo, R&D Program Manager, Todd Pacific Shipyards Corporation, Seattle Division.

Special appreciation is expressed to H. Tamura, M. Muraoka, Y. Tamura, N. Yamamoto, F. Kojima and M. Fukuda, truly professional shipbuilders of IHI's Kure Shipyard, for their contributions and to L.F. McGinnes, School of Industrial & Systems Engineering, Georgia Institute of Technology, for participating in the editing effort. Appreciation is also expressed to Y. Mikami, M. Kuriki and Y. Ichinose, of IHI Marine Technology and to the people in Todd Seattle, particularly D.S. Hunter and A.E. Clark, who furnished essential support.

This book is a cooperative effort by Todd, the Maritime Administration's Office of Advanced Ship Development and the Ship Production Committee of the Society of Naval Architects and Marine Engineers

Transportation  
Research Institute

*This book is dedicated to the memory of  
a ship-material supplier  
from San Francisco, California*

*James A. Stasek  
December 31, 1925 — September 1, 1980*

UNRI

48811

TABLE OF CONTENTS

1.0 Introduction ..... 1  
    1.1 Conformance with Group Technology ..... 1  
    1.2 Work Package Classifications ..... 2  
    1.3 Work Package Productivity Value ..... 4  
    1.4 Versatility and Benefits ..... 5

2.0 An Approach to Product Work Breakdown Structure (PWBS) ..... 7  
    2.1 Dual Grouping ..... 7  
    2.2 Design and Material Definition ..... 7  
    2.3 Producing ..... 9  
    2.4 Controlling ..... 11  
    2.5 Costing ..... 12

3.0 Defining Work Packages ..... 13  
    3.1 Hull Block Construction Method ..... 13  
        3.1.1 Part Fabrication ..... 16  
        3.1.2 Part Assembly ..... 17  
        3.1.3 Sub-block Assembly ..... 17  
        3.1.4 Semi-block and block Assembly and Grand-block Joining ..... 18  
        3.1.5 Hull Erection ..... 19  
    3.2 Zone Outfitting Method ..... 33  
        3.2.1 Zone by Area by Stage ..... 33  
        3.2.2 On-unit, On-block and On-board Outfitting ..... 33  
        3.2.3 Component Procurement ..... 36  
        3.2.4 Unit Assembly and Grand-unit Joining ..... 36  
        3.2.5 On-block Outfitting ..... 37  
        3.2.6 On-board Outfitting ..... 40  
        3.2.7 Operation and Test ..... 41  
    3.3 Zone Painting Method ..... 43  
        3.3.1 Shop Primer Planning ..... 43  
        3.3.2 Primer Painting ..... 43  
        3.3.3 Finish Under-coat Painting ..... 46  
        3.3.4 Finish Painting ..... 46  
    3.4 Integrated Hull Construction, Outfitting & Painting ..... 47

4.0 Pipe Piece Family Manufacturing .....	61
4.1 Work Lots .....	65
4.2 Material Receiving .....	65
4.3 Pipe Fabrication .....	65
4.4 Pipe Piece Assembly .....	65
4.5 Pipe Piece Joining .....	66
4.6 Testing and Costing .....	66
4.7 Palletizing .....	66
5.0 Product Resources .....	67
5.1 Material .....	67
5.2 Manpower .....	71
5.3 Facilities and Expenses .....	72
6.0 Evaluation and Feedback to Estimating .....	73
6.1 Man-hour Expenditures .....	73
6.2 Production Progress .....	73
6.3 Productivity .....	74
6.4 Zone to System Transposition .....	74
7.0 Practical Suggestions .....	77
7.1 Sizing Work Packages .....	77
7.1.1 Quality .....	77
7.1.2 Quantity .....	77
7.1.3 Time .....	78
7.2 Design and Material Definition .....	78
7.2.1 Hull Construction .....	78
7.2.2 Outfitting .....	78
7.3 Material Procurement and Control .....	79
7.3.1 Hull Material .....	79
7.3.2 Outfit Material .....	79
7.4 Producing .....	79
7.4.1 Hull Construction .....	79
7.4.2 Outfitting .....	79

## LIST OF FIGURES

1-1	Reiterative Development of Work Packages . . . . .	2
1-2	Outfit Units . . . . .	3
1-3	Three Dimensional Product Work Breakdown Structure . . . . .	4
1-4	T,N and Q are Interdependent Variables . . . . .	5
1-5	Balanced T,N and Q . . . . .	5
1-6	Work Package Decision Logic Table . . . . .	6
2-1	Dual Grouping in the Management Cycle . . . . .	7
2-2	Product-oriented Design Process. . . . .	8
2-3	ZOFM Design and Production Organizations . . . . .	9
2-4	Integrated Work Processes . . . . .	10
2-5	Integrated Schedules . . . . .	11
3-1	HBCM Manufacturing Levels . . . . .	14
3-2	HBCM Product Aspects . . . . .	15
3-3	Part Fabrication . . . . .	16
3-4	Part Assembly . . . . .	17
3-5	Sub-block Assembly . . . . .	18
3-6	Block Assembly . . . . .	20
3-7	Semi-block and Block Assembly--Bottom Center . . . . .	21
3-8	Block Assembly and Grand-block Joining-Top Wing . . . . .	22
3-9	Semi-block and Block Assembly—Bottom Wing and Side . . . . .	23
3-10	Block Assembly and Grand-block Joining-Bulkhead . . . . .	24
3-11	Block Assembly and Grand-block Joining-Stern . . . . .	25
3-12	Block Assembly-Upper Deck and Engine-room Flat . . . . .	26
3-13	Semi-block and Block Assembly—Bow . . . . .	27
3-14	Semi-block and Block Assembly--Fo'c'sle . . . . .	28
3-15	Grand-block Joining--Fo'c'sle. . . . .	29
3-16	Block Assembly and Grand Block Joining--Engine-roomBottom . . . . .	30
3-17	Block Assembly-Side Shell of Engine Room . . . . .	31
3-18	ZOFM Manufacturing Levels . . . . .	34
3-19	ZOFM Product Aspects . . . . .	35

3-20	Area Subdivisions for Design and Material Preparations . . . . .	36
3-21	Various Outfit-unit Sizes . . . . .	38
3-22	Standard Machinery Unit . . . . .	39
3-23	Lube-oil Cooler Unit . . . . .	39
3-24	Hatch Cover and Coaming Unit . . . . .	39
3-25	General-service Pump Unit . . . . .	39
3-26	Radar Mast and Foremast Units . . . . .	40
3-27	On-block Outfitting--PipeTunnel. . . . .	41
3-28	On-block Outfitting-Engine-room Tank Top . . . . .	41
3-29	ZPTM Manufacturing Levels . . . . .	44
3-30	ZPTM Product Aspects . . . . .	45
3-31	ZPTM Paint Systems . . . . .	46
3-32	Grand Block--Deck and Bulkhead . . . . .	47
3-33	Grand Block--Side Shell . . . . .	48
3-34	Grand Block--Side Shell During Erection . . . . .	48
3-35	On-ceiling Outfitting-Bow . . . . .	49
3-36	On-floor Outfitting-Bow . . . . .	49
3-37	On-ceiling Outfitting-Engine-room Flat . . . . .	50
3-38	Engine-room Flat-After On-floor Outfitting. . . . .	50
3-39	On-floor Outfitting-Engine-room Flat. . . . .	51
3-40	Erection--1st Engine-room Flat . . . . .	51
3-41	On-ceiling Outfitting-Accommodation Start . . . . .	52
3-42	On-ceiling Outfitting-Accommodation Completion . . . . .	52
3-43	Grand-block Joining-Superstructure . . . . .	53
3-44	Keel Laying Plus 11 Workdays . . . . .	53
3-45	Keel Laying Plus 13 Workdays . . . . .	54
3-46	Keel Laying Plus 15 Workdays . . . . .	54
3-47	Keel Laying Plus 19 Workdays . . . . .	55
3-48	Keel Laying Plus 22Workdays--Aft . . . . .	55
3-49	Keel Laying Plus 22 Workdays—Foreward . . . . .	56
3-50	Keel Laying Plus 24 Workdays . . . . .	56
3-51	Keel Laying Plus 24 Workdays-Main Engine . . . . .	57



3-52 Keel Laying Plus 27 Workdays . . . . .	57
3-53 Keel Laying Plus 28 Workdays . . . . .	58
3-54 Keel Laying Plus 29 Workdays . . . . .	58
3-55 Keel Laying Plus 29 Workdays-Completing Superstructure . . . . .	59
3-56 Operation IRON STURT . . . . .	59
4-1 PPFM Manufacturing Levels . . . . .	62
4-2 PPFM Product Aspects . . . . .	63
4-3 Area Subdivisions for PPFM Assembly and Joining . . . . .	64
4-4 Differences in Grouping PPFM . . . . .	64
5-1 Identification Codes for Material . . . . .	68
5-2 Material Cost Classifications . . . . .	68
5-3 Cost Centers . . . . .	70
5-4 Indices for Monitoring Man-hours, Progress and Productivity . . . . .	71
5-5 Cost Classifications and Charging Methods for Facilities and Expenses . . . . .	72
6-1 <b>Management Cycle</b> . . . . .	73
6-2 Manpower Expenditures--Hull Construction . . . . .	75
6-3 Manpower Expenditures--Machinery Fitting . . . . .	75
6-4 Manpower Expenditures--Electrical Assembly Less Cable . . . . .	75
6-5 Manpower Expenditures-IElectrical Assembly Cable . . . . .	75
6-6 Production Progress—Hull Construction . . . . .	75
6-7 Productivity--Parts Fabrication . . . . .	75
6-8 Productivity--Subassembly and Block Assembly . . . . .	76
6-9 Productivity--Erection . . . . .	76
6-10 Productivity--Machinery Fitting . . . . .	76
6-11 Productivity--Electrical Fitting Less Cable . . . . .	76
6-12 Productivity Control Group . . . . .	76

*“A productive shipbuilding industry  
is an indispensable element of seapower. ”*

*The Editor*

*“Whosoever commands the sea commands  
the trade; whosoever commands the trade  
of the world commands the riches of  
the world, and consequently, the  
w o r l d i t s e l f”*

*Sir Walter Raleigh  
1552 — 1618*

## 1.0 INTRODUCTION

The work required for any large construction project must be subdivided in order to be readily analyzed and managed. Any such subdivision scheme is a work breakdown structure.

Traditional shipbuilders employ work subdivisions by ships' functional systems which are natural and appropriate for estimating and for early design stages. However, system orientation for planning, scheduling and execution is unnatural and inappropriate because it leads to poor coordination of work and generally results in work packages which are too large for effective control of material, manhours and schedules.

The way that ships, and most other manufactured artifacts, are actually produced is by procuring or fabricating parts and joining them to create subassemblies. In turn, these are combined through several manufacturing levels to produce increasingly larger subassemblies. Thus, the ideal way to subdivide ship-construction work is to focus on needed parts and subassemblies, i.e., the actual interim products that preoccupy workers. A scheme to subdivide work in accordance with an interim-product view, is a product-oriented work breakdown structure.

The need for a product-oriented work breakdown structure which conforms with the way a ship is built was identified for U.S. shipbuilders over a decade ago.<sup>1</sup> At that time there were already substantial applications by some shipbuilders abroad.

### 1.1 Conformance With Group Technology

Unlike system-oriented methodologies, product orientation facilitates identifying work by classes of problems. Where applied and exploited by shipbuilders, the logic and principles of Group Technology (GT) emerged independent

of similar developments elsewhere to enhance machine tool usage.<sup>2</sup>

In industries which produce machined parts, GT is a means for improving productivity, even for a variety of custom requirements, by grouping parts by their common characteristics. The basis for such groups, or families, is that there are common processes for the manufacture of all parts within a group. Thus, parts are classified by both design and manufacturing attributes which are reflected in coding schemes. The codes typically address form, dimensions, tolerances, material, and types and complexity of machining operations. They reflect need for exact identification of previously manufactured parts for the purpose of retrieving process standards.

In shipbuilding it is the interim products, i.e., fabricated parts and various Subassemblies, which are susceptible to similar classification by the problems their manufacture imposes. Such classifications are the singular means used by the world's most competitive shipbuilders to plan work. They are able to more uniformly distribute work between contract award and delivery for each ship and better coordinate the outputs of work-process lanes even for a simultaneous mix of ship types and sizes. Thus, they achieve many of the benefits of batch manufacturing while producing interim products that are manifestly unlike each other.<sup>3</sup>

Unique classification by certain *product aspects* conventionally relate a part or subassembly to a *system* or zone of a ship design and also to the work processes by problem *area* and by work *stage*. Thus, product aspects are classifications for both design and manufacturing attributes. This concept combined with a greater degree of interaction between design and production specialists has proven to be a powerful means for improving productivity.<sup>4</sup>

---

<sup>1</sup>"A Study of Shipbuilding Cost Estimating Methodology" for the maritime Administration by Engineering & Management Sciences Corporation dated 20 January 1969.

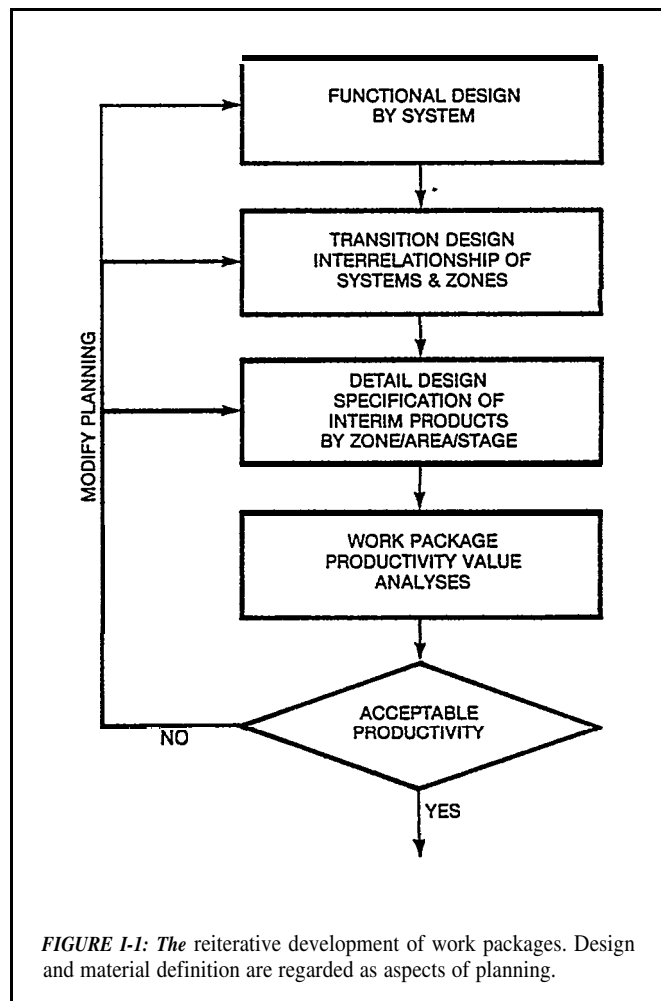
<sup>2</sup>Group Technology is "...the logical arrangement and sequences of all facets of company operations in order to bring the benefits of mass production to high variety, mixed quantity production." Group Technology A Foundation for Better Total Company Operation, G.M. Ranson, McGraw-Hill, London, 1972, p.1. Group Technology is also called Family Manufacturing.

<sup>3</sup>Also called pseudo-batch manufacturing.

<sup>4</sup>Where successfully applied there is much dependence on field engineers. In the Aioi Shipyard of Ishikawajima-Harima Heavy Industries Co., Ltd. (IHI), nearly 2% of the 1060 people assigned to hull construction fabrication and assembly are field engineers. They number almost 6% of the 715 people so assigned to outfitting and painting. Circa June 1980.

Work packages classified by product aspects are systematically analyzed in order to determine their productivity values. As shown in Figure 1-1, the analyses may be reiterative through several planning levels. Where such investment is made, the work packages are immediately improved based upon restudy following production. Thus, the work packages reflect an accumulation of experiences. They are, to a remarkable degree, adaptable to ships of different sizes and types, therefore initial costs justify amortization over subsequent ship construction projects.<sup>5</sup>

The independent emergence of the logic and principles of GT in shipbuilding caused the development of codes which typically address type of work, resources required and unique product aspects. The latter include zone codes which designate disposition of an interim product for later assembly of a larger interim product. Significantly, the



codes do not reflect need to identify whether a particular interim product has been made before as the classifications apply to ship designs of any type and size that are customized to any degree.

Emphatically, the codes do provide for identification of work problems imposed. Thus, interim products which are different looking from each other and for different ships, are grouped together for processing in accordance with a common set of solutions; see Figure 1-2.

## 1.2 Work Package Classifications

The concepts of the Product Work Breakdown Structure (PWBS) described herein, Group Technology (GT) and Family Manufacturing (FM) are similar. All feature classifications to permit grouping of products by similarities in production problems without regard for end-use systems. Logically the PWBS first divides the shipbuilding process into three basic types of work: *hull construction*, *outfitting* and *painting*, because each imposes problems that are inherently different from the others'. Further, each is readily subdivided into *fabrication* and *assembly* types of work.<sup>6</sup> It is these assembly subdivisions that are naturally linked to zones and which are the basis for zone dominance in the management cycles of the most competitive shipbuilding firms. Zone-oriented production, i.e. the Hull Block Construction Method (HBCM), is already being applied for hull construction by most shipyards. But, the same logic is not yet everywhere employed for outfitting by zones which is more complex and difficult to undertake.

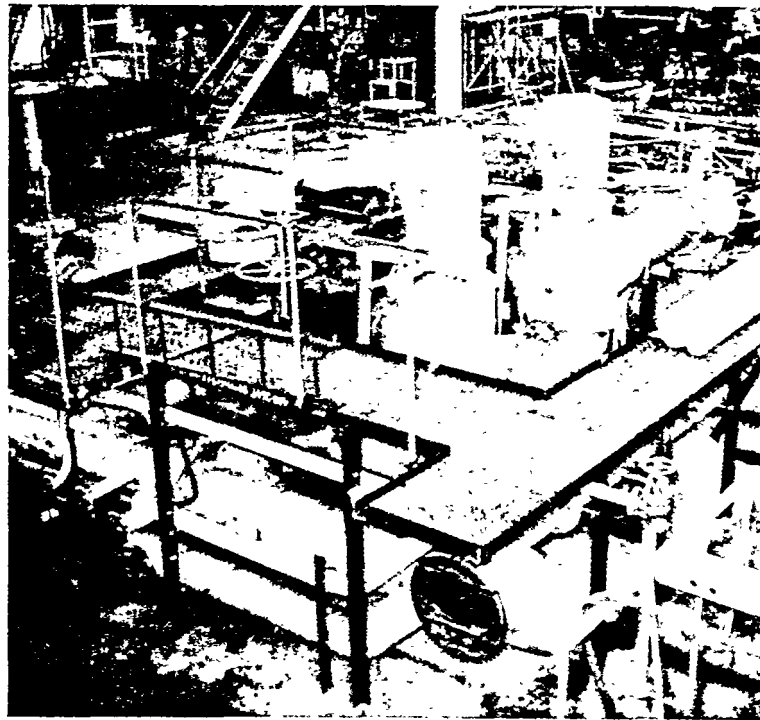
Secondly, PWBS classifies interim products in accordance with their needs for resources, i.e. material, manpower, facilities and expenses. Thus for example, different structural panels regardless of their intended locations in a ship, have resources classified and allocated in accordance with common parameters. Likewise, different outfit units are treated the same way. Definitions of the *product resources are:*

- **Material**, to be used for production, either direct or indirect, e.g., steel plate, machinery, cable, oil, etc.
- **Manpower**, to be charged for production, either direct or indirect, e.g., welder, gas cutter, fitter, finisher, rigger, material arranger, transporter, etc.
- **Facilities**, to be applied for production, either direct or indirect, e.g., buildings, docks, machinery, equipments, tools, etc.
- **Expenses**, to be charged for production, either direct or indirect, e.g., designing, transportation, sea trials, ceremonies, etc.

<sup>5</sup>Regardless of differences in functional systems, zone/area/stage classifications of comparable work packages for different size ships of the same type, change very little. Even for different type ships, such classifications remain essentially the same for work related to bows, sterns, engine rooms and superstructures

<sup>6</sup>*Painting-fabrication* applies to the manufacture of paint; *painting-assembly* applies to its application. The former is usually not applicable in shipyards.

<sup>7</sup>A methodology for zone outfitting was introduced to U.S. shipbuilders by the publication of "Outfit Planning -December 1979" by C.S. Jonson and L.D. Chirillo, for the National Shipbuilding Research Program.



**FIGURE 1-2:** Outfit units which are dissimilar in arrangement and in functions incorporated, have the same classification in a product-oriented work breakdown structure because the problems associated with their assembly are the same.

In order to optimize productivity in realistic circumstances, a ship must be constructed in accordance with a carefully established plan that envisions:

- processes for manufacturing parts and subassemblies leading to outfit units and structural blocks within time frames that can be coordinated, and
- simultaneous use of each process for the requirements of different systems even in different ships.

The third classification, by the four product aspects, addresses these needs because it contains essentials needed for control of production processes.

Two product aspects, *system* and *zone* are means for dividing a *ship design* into planned manageable parcels. Each, for example, can apply to a number of parts or to one specific assembly. Each of the latter is usually addressed by a separate work package. The other two product aspects, *area* and *stage*, are means for dividing the *work process* from material procurement to complete ship delivery. The product aspects are:

- **System** - A structural function or an operational function of a product, i.e., longitudinal bulkhead, transverse bulkhead, mooring system, fuel-oil service system, lighting system, etc.
- **Zone** - An objective of production which is any geographical division of a product, e.g., cargo hold,

superstructure, engine room, etc., and their sub-divisions or combinations [e.g., a structural block or outfit unit, a subassembly of either and ultimately a part or component).

- **Area** - A division of the production process into similar types of work problems which can be
  - by feature (e.g., curved vs. flat blocks, steel vs. aluminum structure, small diameter vs. large diameter pipe, pipe material, etc.)
  - by quantity (e.g., job-by-job vs. flow lane, volume of on-block outfitting for machinery space vs. volume of on-block outfitting for other than machinery space, etc.)
  - by quality (e.g., grade of workers required, grade of facilities required, etc.)
  - by kind of work (e.g., marking, cutting, bending, welding, blasting, bolting, painting, testing, cleaning, etc.), and
  - by anything else that creates a manifestly different work problem.
- **Stage** - a division of the production process by sequences, e.g., sub-steps of fabrication, sub-assembly, assembly, erection, outfitting on-unit, outfitting on-block, and outfitting on-board.

The three-dimensional nature of the Product Work Breakdown Structure (PWBS) described in the foregoing is illustrated in Figure 1-3.

### 1.3 Work Package Productivity Value

When an interim product is identified by product aspects, it is necessary to evaluate its efficiency as a work package which can be expressed by the formula

$$PV = f(T, N, Q)$$

where:

PV = productivity value, i.e., the productive efficiency of a work package

T = time allowed for its accomplishment, i.e. working time

N = number of units of resources; particularly components in the material list and man-hours allocated

Q = quality of work circumstance, e.g., downhand vs. overhead, high vs. low, etc., and also quality specified for the interim product

T, N and Q are interdependent and as shown in Figure 1-4 they impact differently on PV. As they cannot be evaluated separately it is useful to symbolize PV as a triangle having sides that represent T, N and Q. Optimum PV is then represented by an equilateral triangle, see Figure 1-5. In

other words, PV is optimized when the influences of T, N and Q are balanced.

The function  $f(T, N, Q)$  must be determined empirically by each shipyard and separately for each classification of the production process by problem area. In addition, each such determination must consider the immediate preceding and following work stages. For example, Q includes consideration of the quality specified for an interim product. If its contribution to PV is not enough, the quality of the interim product is not good enough for a larger assembly.

Further, productivity values cannot be precisely determined. Therefore, they are guidance to serve a judgemental process for evaluating work packages. Their use at first involves trial and error and thereafter experience. For example a geographical division of a product into seemingly ideal zones, could yield unacceptable work packages when the needed work processes are analyzed by problem areas. Zone boundaries would then be adjusted until there is an ideal compromise of zone and area considerations. Each proposed work package should be so evaluated regardless of whether it has been employed in the past. It is probable that some circumstance, especially regarding resources and time available, will have changed.

Figure 1-6 shows the applicability of PWBS to a variety of industrial methods. It is a decision logic table for evaluating work packages associated with all of the theoretically available combinations of product aspects. Where ex-

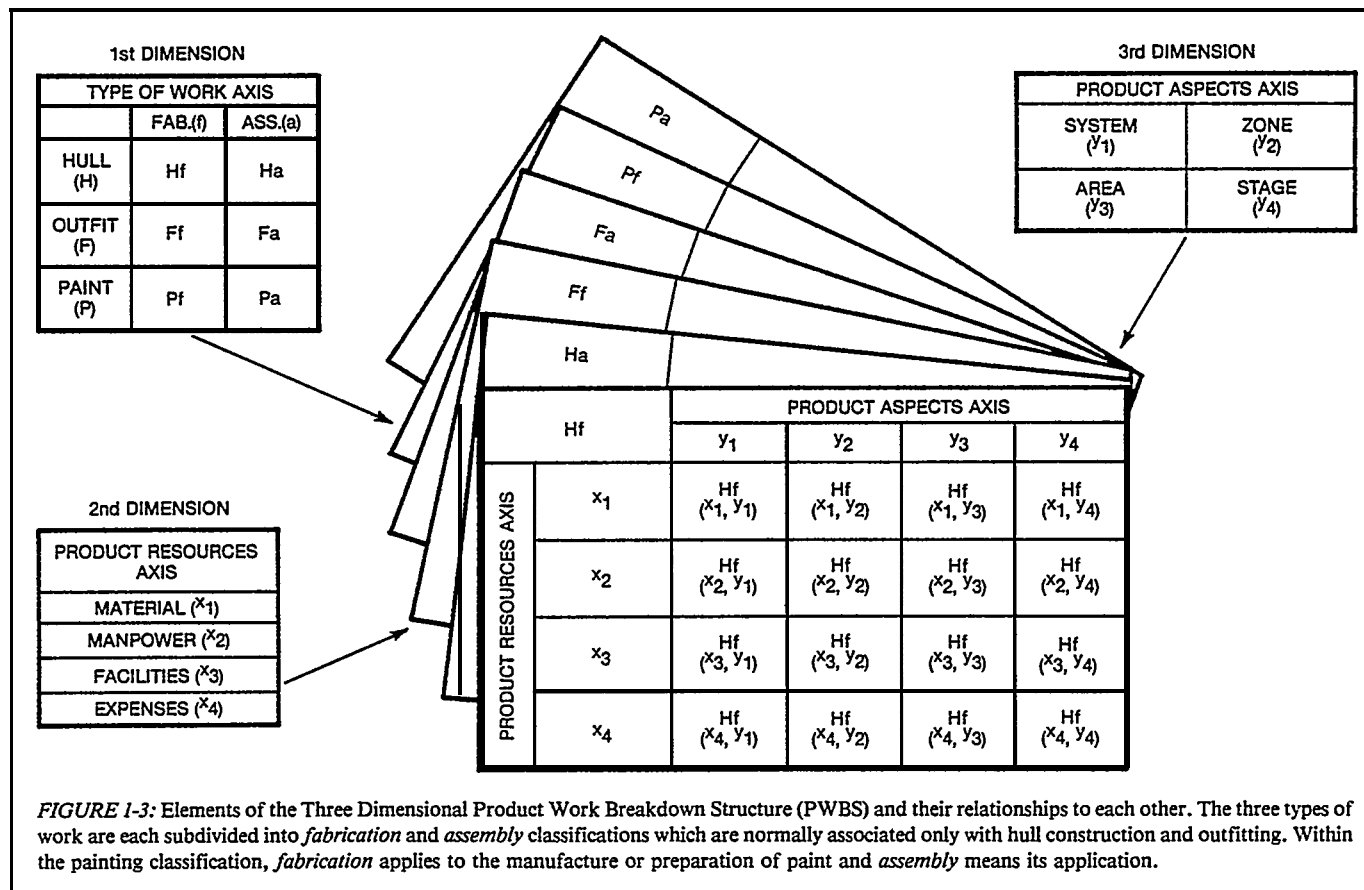
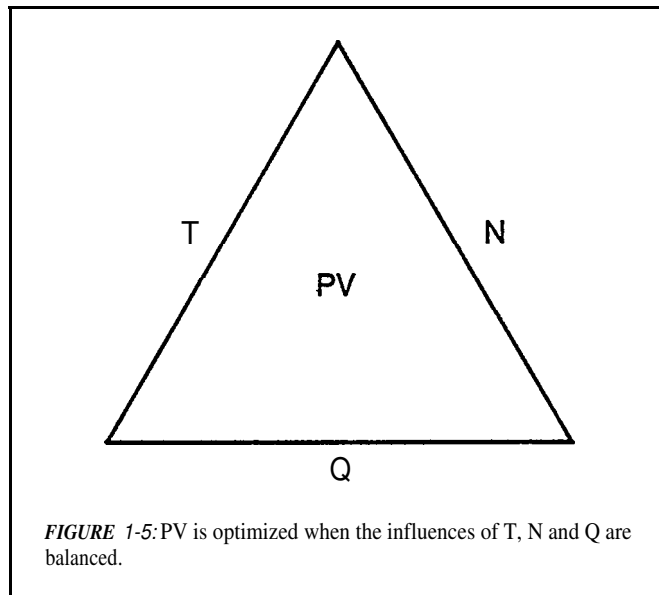
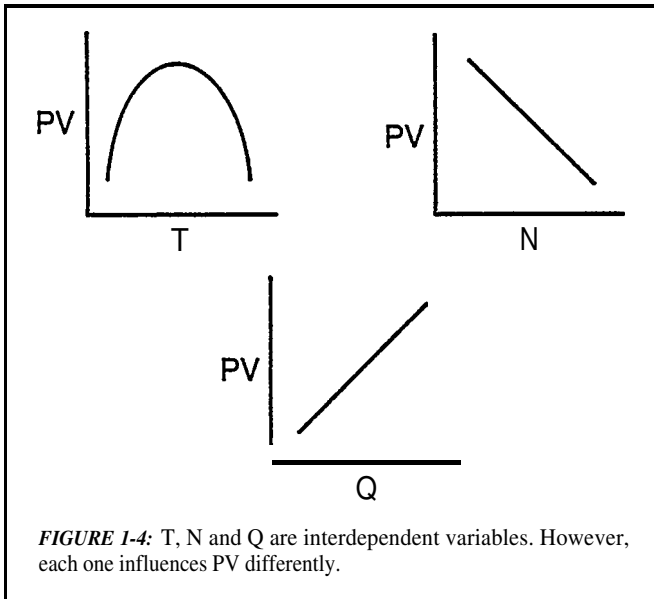


FIGURE 1-3: Elements of the Three Dimensional Product Work Breakdown Structure (PWBS) and their relationships to each other. The three types of work are each subdivided into *fabrication* and *assembly* classifications which are normally associated only with hull construction and outfitting. Within the painting classification, *fabrication* applies to the manufacture or preparation of paint and *assembly* means its application.



perience exists, many evaluations are not necessary and some are performed intuitively. The remainder are evaluated with the assistance of equations similar to that described in the foregoing.

**1.4 Versatility and Benefits**

From a product-oriented viewpoint each work package can address, theoretically, all four of the product aspects. But sometimes to fulfill other needs certain product aspects may be disregarded. When zone is eliminated, grouping is made by system, area and stage. This is the traditional System (-oriented) Work Breakdown Structure (SWBS). If system is deleted, grouping is made by zone, area and stage. This is called a Zone (-oriented) Work Breakdown Structure (ZWBS). If both system and zone are disregarded, grouping is by area and stage. This is an area-oriented work breakdown structure, a term not generally used. Figure 1-6 is marked to show specific examples of system, zone and area orientations.

Shipbuilding methods have consistently become more productive during the past three decades mainly because of the change from traditional system-oriented processes to the following zone-oriented processes:

- Hull Block Construction Method (HBCM),
- Zone Outfitting Method (ZOFM), and
- Zone Painting Method (ZPTM).

Further productivity increases were achieved by adoption of the area-oriented Pipe Piece Family Manufacturing Method (PPFM). These proven concepts have significantly contributed to:

- simpler assembly methods,
- the rationalization and automation of facilities, and
- more uniform and simultaneous workloads for fabrication shops and assembly teams.

Their benefits are manifested by:

- improved safety,
- improved work environments,
- better quality, and
- higher productivity.

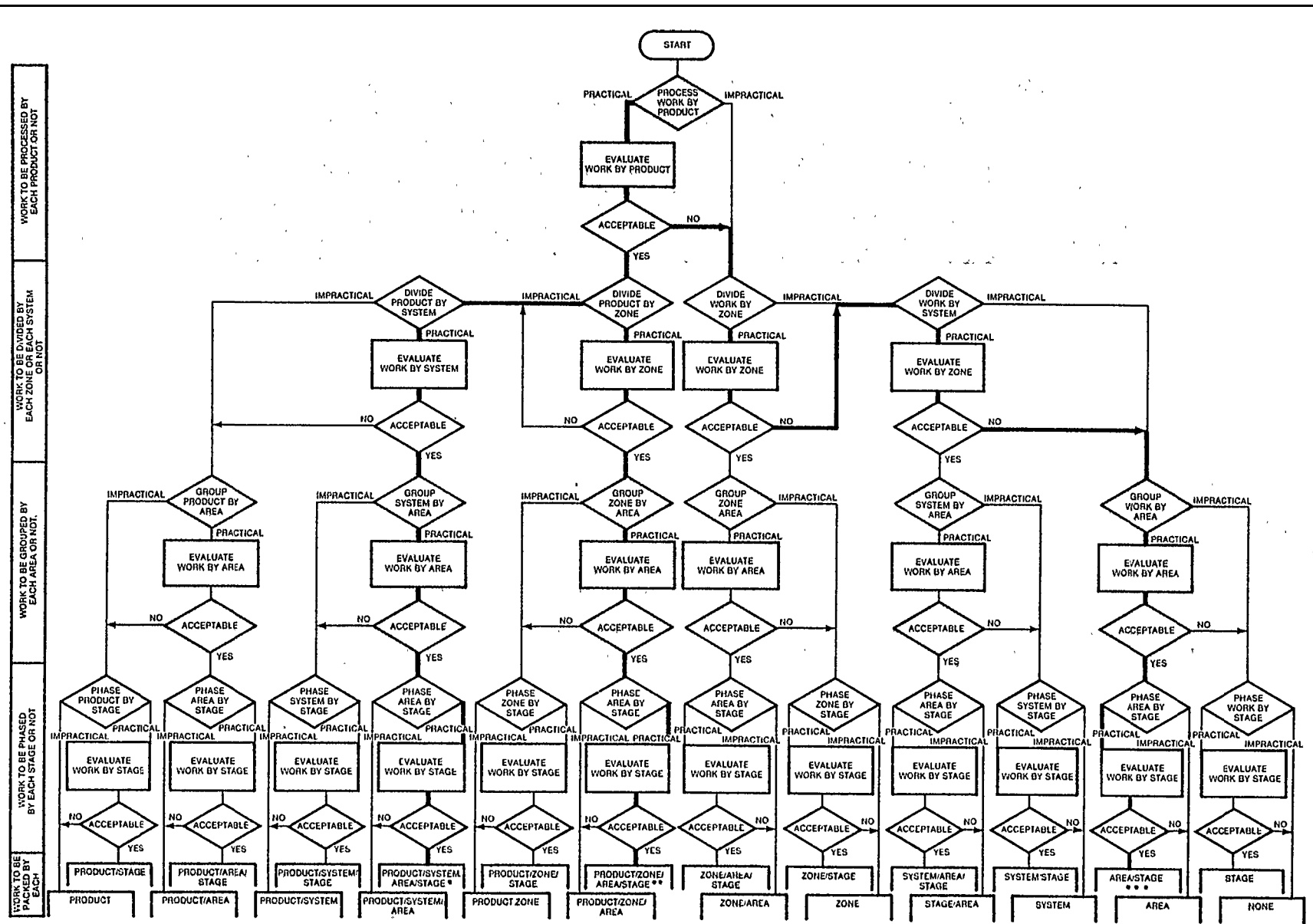


FIGURE 1-6: Work Package Decision Logic Table by Product Aspects. The combinations shown in the bottom row are theoretically derived. Therefore, some may not exist in a practical sense. The three decision paths which are especially marked are applicable to:

- \* traditional system-oriented outfitting and pipe-piece manufacturing.
- \*\* zone-oriented Hull Block Construction Method (HBCM), Zone Outfitting Method (ZOFM) and Zone Painting Method (ZOPM), and
- \*\*\* area-oriented Family Manufacturing (FM).



## 2.0 AN APPROACH TO PRODUCT WORK BREAKDOWN STRUCTURE (PWBS)

Many shipyards are equipped with modern enough facilities having sufficient capacity to build many types and sizes of both commercial and naval ships. However, the periods usually allowed for design and production are much longer than that needed by competitive shipbuilders with comparable facilities. As a consequence, their production levels relative to facilities are unnecessarily low. Significant reasons for this state of affairs are their adherence to system-oriented work breakdowns, continued dependence on system-oriented design and production organizations, and dependence on divisions of ship designs by systems for allocations of material and manpower.

### 2.1 Dual Grouping

In conventional shipbuilding, all functions of the management cycle, i.e., estimating, planning, scheduling, executing and accounting, are consistently system oriented. Cost classifications for estimated material and manpower requirements are by system. Typically, drawings and material lists are issued per system and work packages are broken down within each system for scheduling, executing and evaluating. From a limited managerial viewpoint, such consistency is favorable.

In contrast, PWBS has more than one character. It permits dual groupings, e.g., work packages by product aspects and cost classifications by product resources. Thus, manpower expenditures can be collected by zone/area/stage while material costs can be collected by system. The unique multiple character of PWBS is illustrated in Figure 2-1.

### 2.2 Design and Material Definition

The transformations of design and material definition from system to zone orientations are illustrated in Figure 2-2. As shown, a ship as a total system is separated into individual systems on functional drawings for which material lists by system are prepared. *Transformation* to zone orientation begins with a block plan for hull construction and composite drawings for outfitting. These incorporate all systems and show zone boundaries. They are further processed to add area/stage considerations which for hull construction are designated on assembly, subassembly and cutting plans. For outfitting, they are designated on working drawings (work instruction drawings) each of which is developed together with its own material list of fittings for either on-unit, on-block or on-board outfitting. The hierar-

chical subdivision continues by zone/area/stage with the preparation of detail design drawings for pipe pieces and components other than pipe and their respective material lists. As also shown in Figure 2-2, the planning process continues until each zone is broken down to a minimum level, i.e., components that are to be purchased and the material requirements for such parts that are to be fabricated.

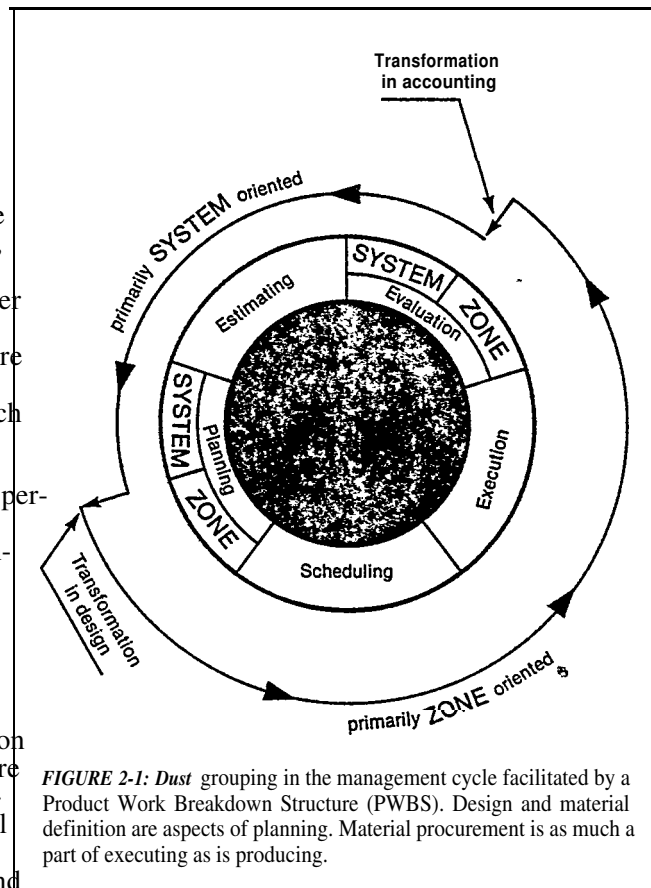


FIGURE 2-1: Dual grouping in the management cycle facilitated by a Product Work Breakdown Structure (PWBS). Design and material definition are aspects of planning. Material procurement is as much a part of executing as is producing.

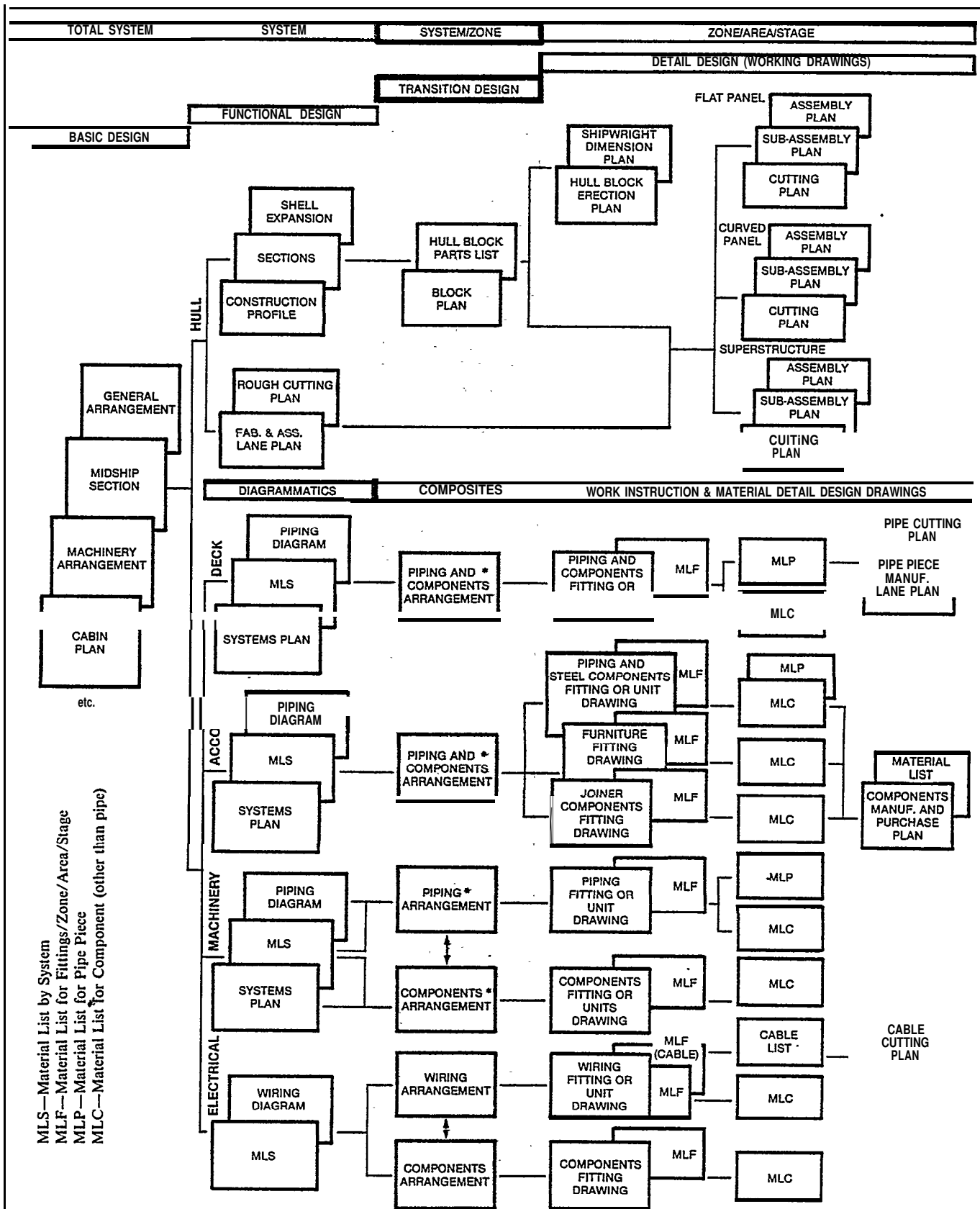
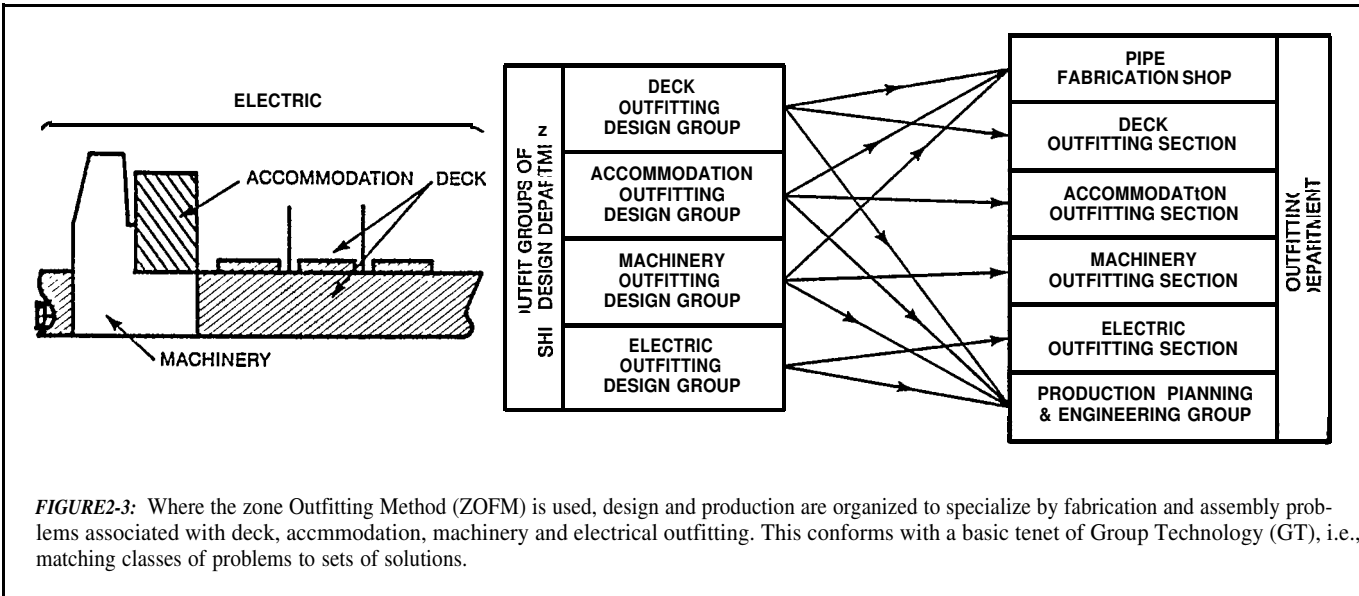


FIGURE 2-2: Pridyct-oriented Design Process. Transition Design introduces zones and interrelations with systems. The items marked "\*" are sometimes freehand. But, they are sufficient for quickly conveying arrangements and system/zone relationships to detail designers. The latter refine the arrangements and designate stages during preparation of work instruction and material detail-design drawings.



Product-oriented design features a sequence for grouping product aspects, i.e., by total system, individual system, system/zone and zone/area/stage. These groupings are respectively employed in basic design, functional design, *transition* design and detail design. Obviously, there is a need to manage a transition which interrelates systems and zones for each ship design as is already being done for hull construction by some shipbuilders who have not totally adopted zone orientation.

The zone-oriented Hull Block Construction Method (HBCM) achieved acceptance in traditional design organizations probably because in these organizations, all hull structural systems are assigned to a single design group. This facilitates the coordination needed to produce a block plan which accurately reflects the apportionment of parts of hull systems to specific blocks.

In contrast, the outfit systems are assigned to separate design groups in a traditional design organization. This separation of design responsibilities by system is satisfactory for functional design but is not suitable for detail design. It perpetuates preparation of expensive and unnecessary system-arrangement drawings resulting in delayed preparation of needed composite drawings. Primarily because of the multiplicity of outfit design groups, it is difficult to define interim products on detail design drawings by zone/area/stage and to provide structured material lists. Both are essential for zone-oriented material procurement and for control of work flows in process lanes.

Therefore, where zone outfitting has been adopted some shipbuilders have reorganized design, and even production, by classes of problems. Typical such classes as shown in

Figure 2-3, are *deck, accommodation, machinery and electrical*. People representing the various system disciplines are assigned to a-group having responsibilities for a single production-problem class. Within such groups there is improved "horizontal" communication such as that between piping and vent duct designers assigned to machinery outfitting. They become more expert about their particular class, are led away from insignificant fine tuning of systems, and instead focus on composite drawings marked to show how a ship is to be assembled and on structured material lists. They have *eliminated* system arrangement drawings and have developed surprisingly interference-free and simplified composites (drawings or scale models) directly from **diagram-matics**.

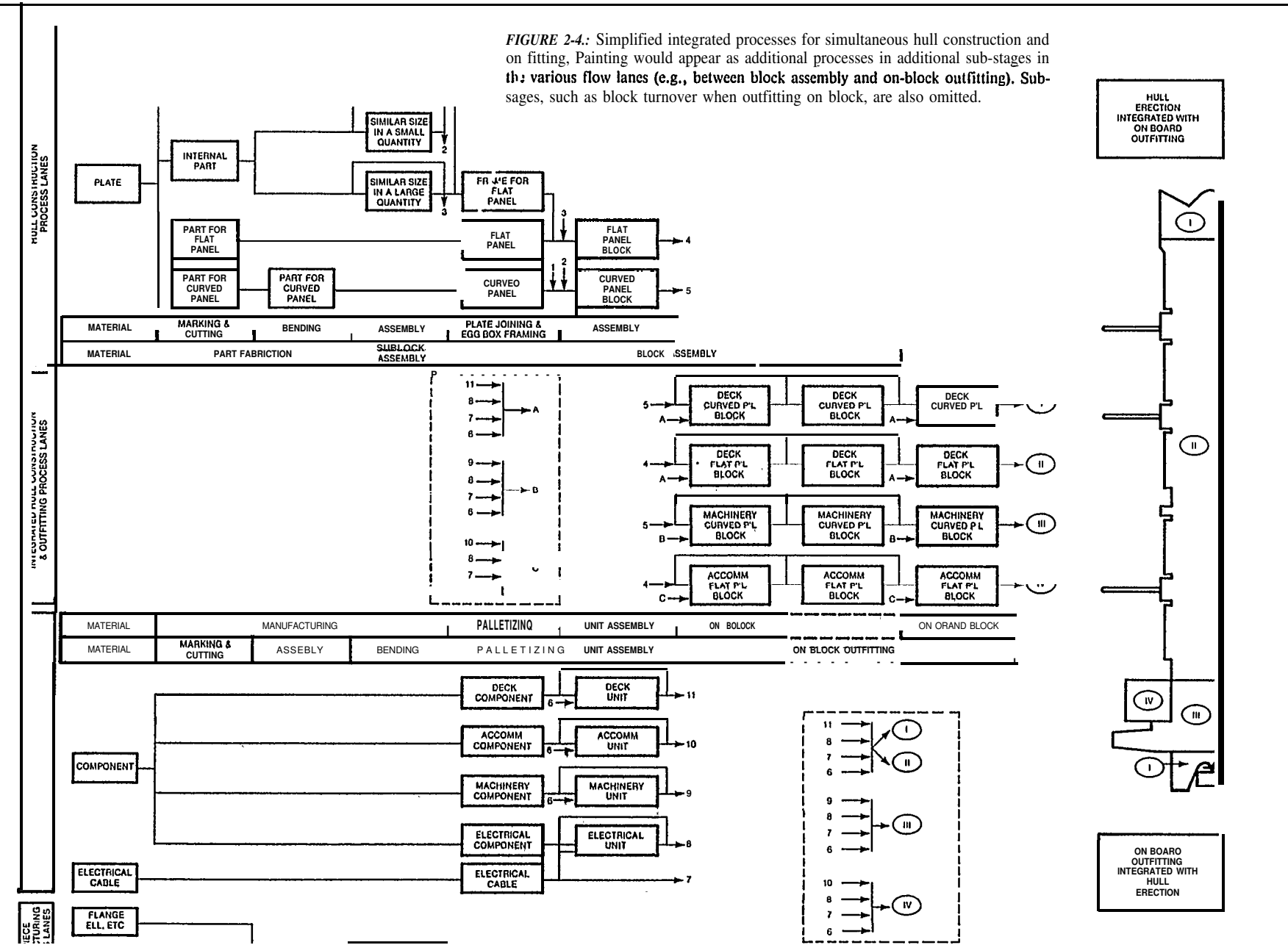
### 2.3 Producing

Figure 2-4 shows work process lanes, organized by classes of problems, and how their end products must integrate for zone-oriented production. Fabrication shops and assembly sections are grouped along the various process lanes.

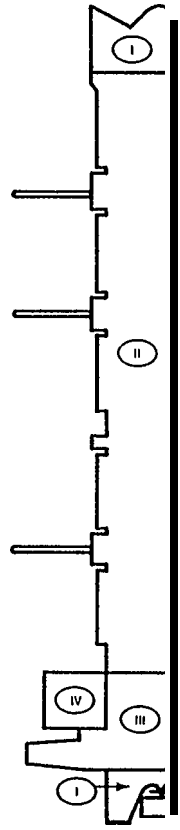
Traditionally, hull construction has always been assigned to a single producing division associated with a single trade union. Therefore, the general adoption of hull block construction in process lanes similar to those illustrated in Figure 2-4 is not surprising. However, the outfit and integrated (hull construction and outfit) process lanes shown are quite different from those of shipbuilders who still use system-oriented work packages for outfit fabrication and **assembly**.

Incorporating *electrical* as a fourth classification is a concession to tradition. Perhaps when there is general use of electric-cable splices solely to facilitate shipbuilding, assembly of electrical systems will be Planned just as if they were pipe or vent-duct systems. If the latter is unacceptable to traditionalists, it is more logical to classify *electrical* as a type of work analogous to hull construction, outfitting and painting.

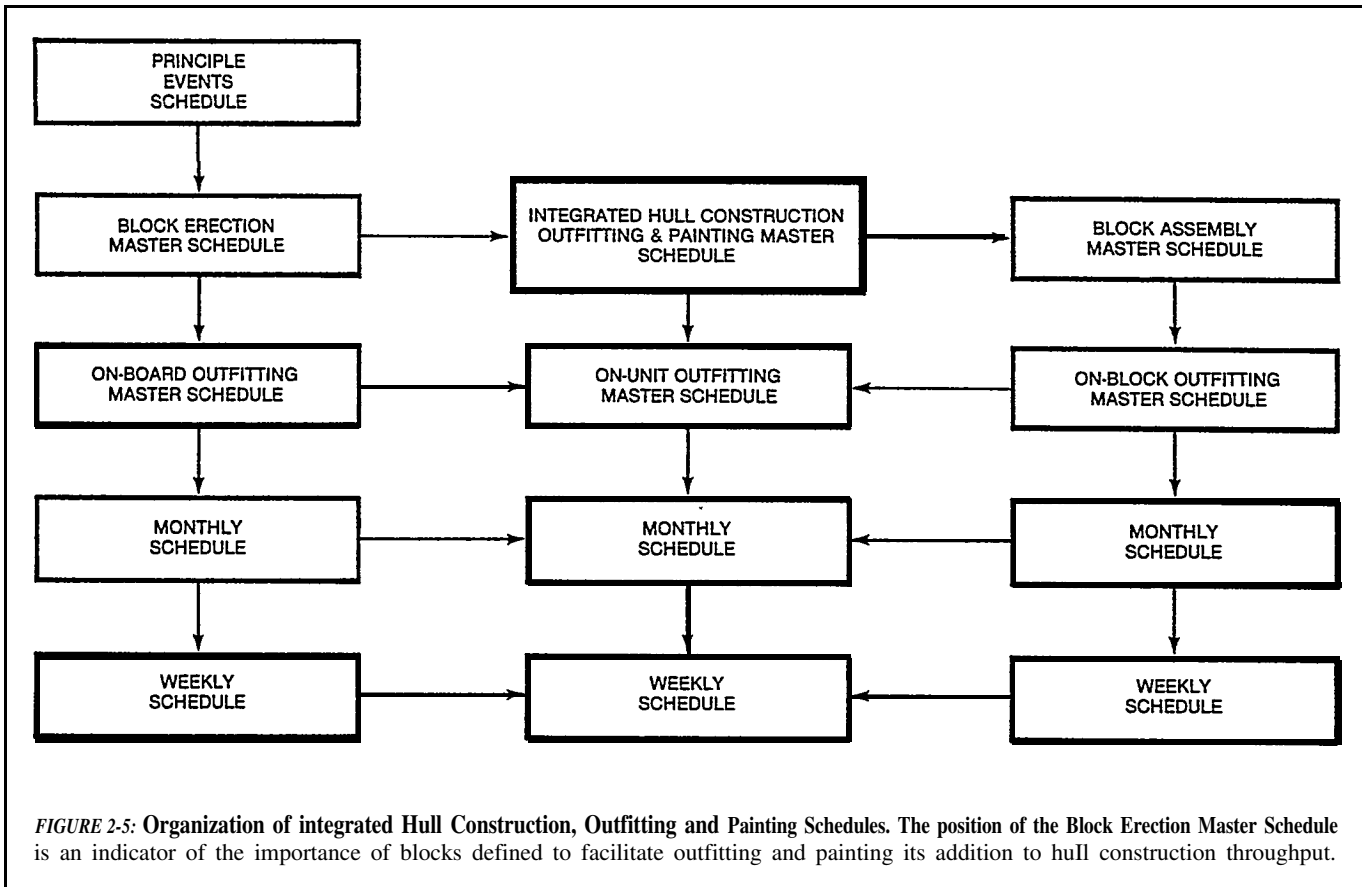
FIGURE 2-4: Simplified integrated processes for simultaneous hull construction and on fitting. Painting would appear as additional processes in additional sub-stages in the various flow lanes (e.g., between block assembly and on-block outfitting). Sub-stages, such as block turnover when outfitting on block, are also omitted.



HULL ERECTION INTEGRATED WITH ON BOARD OUTFITTING



ON BOARD OUTFITTING INTEGRATED WITH HULL ERECTION



For example, in a system-oriented production organization workers are assigned to a pipe shop which fabricates and assembles pieces required for all pipe systems. In a zone-oriented organization, such workers are assigned either to a fabrication shop or to a team specialized for a specific category of assembly problems. In addition to assembling all but high pressure pipe, each fitter assembles everything for which a manual “stick” welder or spanner wrench suffices, e.g., pipe supports, walkways, handrails, electric-cable trays, pipe and vent-duct pieces, etc. Other trades represented on a team are as needed for special or extensive welding, rigging, insulating, joinery, etc.<sup>2</sup>

Even where traditional system-organizations exist, there are means for an almost equally effective assignment of manpower. At least one shipyard, having a contract with one labor union which includes all trades, can assign people of one trade to assist those of another to a reasonable degree. Further in another shipyard, the introduction of just zone-oriented hull construction has contributed to the combining of many related specialists into two, i.e., a fitter who does some welding and a welder for special or large amounts of welding. Therefore it is probable that a general understanding of the benefits of zone outfitting will similar-

ly encourage development of an “outfitter” trade as described in the foregoing paragraph.

Zone-oriented worker skills should not be isolated to just an objective of management because they are also credited for significantly improving safety, work environment, quality and productivity. All are justification to include zone outfitting in the bargaining positions of both labor and management.<sup>3</sup>

#### 2.4 Controlling

Zone-oriented scheduling is necessary to control the flows of work on various process lanes so that the creation of interim products anticipates only immediate needs. Such scheduling coordinates hull construction, outfitting and painting and allows periods after work stages for the collection and distribution of interim products to other work stations. The goal is to minimize buffer stowages. Thus, integrated schedules as shown in Figure 2-5 are essential for the period starting with fabrication through final outfitting. The schedules should address all fabrication and assembly work including lofting and painting.

<sup>2</sup> A zone-oriented work team is consistent with the Volvo approach to job enrichment. Just as Volvo assigns a team to do all work to assemble an automobile, some shipbuilders abroad assign a team that is specialized in the production of interim products of a particular problem class.

<sup>3</sup> Some unionists advocate productivity improvement as a means for achieving job security. As a consequence of a few steel plant shutdowns the President of the United Steel Workers said “Where we see poor maintenance or the failure to innovate and stay modern we will make such matters a subject of discussion with management.” Business Week: December 24, 1979; p 46.

The most detailed schedule, e.g., a weekly schedule, should be based upon work packages which, ideally, are sized for work to be performed by two people in one week. Such work package sizes, relatively small compared to those used for system-oriented methods, facilitate control of work flows and accurate progress reporting of manpower and material costs by zone/area/stage.

The need for small work packages cannot be understated. With structured material lists they are the very essence of control because

- . progress determinations are based upon only tangible aspects, i.e., material is either unassembled or assembled<sup>4</sup>, and
- the greater number of work activities enhance flexibility.

Flexibility, i.e., the wherewithal to quickly identify good options based upon constant feedback about material procurement and work progress, is necessary for successful use of PWBS. Adjustments are needed to counter potential delays and early completions. Adjustments could include transfer of workers between process lanes, the use of overtime or short term schedule changes. The objectives are to maintain uniform work flow within each process lane and **coordinated outputs from all process lanes.**<sup>5</sup>

Composing the prerequisite work packages could be a major stumbling block without the benefit of prior experience, particularly for shipyards which have not yet instituted the Hull Block Construction Method (HBCM). However, the goal is clear; work packages per ship should be uniform in work content as much as possible. Regardless of the difficulties, managers have to keep in mind that work by system is inherently associated with diminished control. System orientation features relatively large work packages which do not address modern shipbuilding methods. Primarily they are ineffectual for control because they require execution over relatively long time periods. It is axiomatic, without effective control, costs are higher regardless of the disciplines applied for their collection.

## 2.5 Costing

Zone orientation introduced the powerful concept of control linked to many relatively small amounts of material grouped by zone/area/stage. Where applied, progress reporting and cost collections are zone oriented so that managers have tangible means of corroborating work completed in order to forecast work remaining and resources required for completion. In order to serve estimators, manpower costs by system have to be rationalized. Certain indices, described in Chapters 5.0 and 6.0 are needed for distribution of spent man-hours to systems.

The indirect collection of costs by system may seem to some people to be a degradation of feedback to estimators. However, systems-oriented large or open-ended work packages are commonly abused to absorb other work or idleness caused, for example, by the insufficient availability of work. Thus, while collecting costs by a zone-oriented method and applying them to systems in accordance with estimated distributions is less precise, it produces more accurate data due to inherently better control.

Because of the multiple character of PWBS, material usage is easily collected both by system and zone. Where functional designers are required to identify all materials per system diagrammatic, there is quick corroboration of the material estimate. If a catastrophic error is disclosed there is time for remedial measures before the major procurement effort begins.

Further, when functional designers are additionally required to divide each material list by system into lists of material required for various material ordering zones, it is possible to quickly corroborate estimated manpower requirements. This is feasible when the system/zone transformation indices are based upon material, e.g., man-hours/hundredweight of fittings, manhours/foot of electric cable, etc. Where these techniques are applied, the rapid feedback to estimators is of sufficient accuracy for immediate use in preparing another estimate.

All material requirements are listed by system for purchasing and subsequently on structured material lists for issue purposes. Therefore, the interrelationships maintained by designers permit material progressing by zone to be accurately converted to material progressing by system if a customer so desires. Similarly, the system/zone transformation indices could serve a customer's requirement to progress manpower by system.

---

<sup>4</sup> A senior manager in the world's foremost shipbuilding industry said "In Japan we have to control material because we cannot control people." Y. Mikami to L. D. Chirillo, June 1980.

<sup>5</sup> An accuracy control philosophy practiced in Japan addresses, in addition to avoidance of inaccuracies, the wherewithal to quickly identify the best option when an inaccuracy jeopardizes scheduled work flow. Knowledgeable people, assigned collaterally to an accuracy-control committee, respond quickly estimate rework and to recommend where and when it should be performed.

### 3.0 DEFINING WORK PACKAGES

Because inherently different types of work are required, a product-oriented breakdown of ship construction work should anticipate the following zone-oriented methods:

- Hull Block Construction Method (HBCM),
- Zone Outfitting Method (ZOFM), and
- Zone Painting Method (ZPTM).

Also, because large quantities and varieties of pipe pieces are needed, the work breakdown should anticipate area-oriented Family Manufacturing (FM).

Work packages are ideally sized for the three zone-oriented methods when for each process lane:

- their required working times for all manufacturing levels are the same, and
- within each manufacturing level, their work amounts are the same.

Compliance with these conditions permits each process lane to be operated as an assembly line where work starts, flows and stops in unison. In order to balance work accordingly, special manufacturing levels outside the main flow are needed to adjust work amounts and to provide for interim-product features that would otherwise be disruptive.

#### 3.1 Hull Block Construction Method (HBCM.)

Ideal blocks, i.e. zones, are key objectives as the basis for control in HBCM. But, blocks also impact on zone outfitting and painting. Therefore the definition of blocks, compared to that for other interim products, has the greatest influence on shipbuilding productivity.

Blocks should be designed so that:

- for block assembly purposes, they are assignable to one of a minimum number of work package groups considering similarities in problem area and the need to minimize variations in working times,

for block erection purposes, they will be stable configurations requiring no temporary support or reinforcement and otherwise shaped to achieve minimum working times, and

- for on-block outfitting and painting, they are sized for maximum space (area and/or volume).

Also, there should be similarities in volume, weight, shape, etc., even at the expense of design convenience, in order to distribute work evenly throughout the fabrication and assembly levels which precede block assembly. Thus, planners have to keep in mind that breaking down the work leading to block assembly requires:

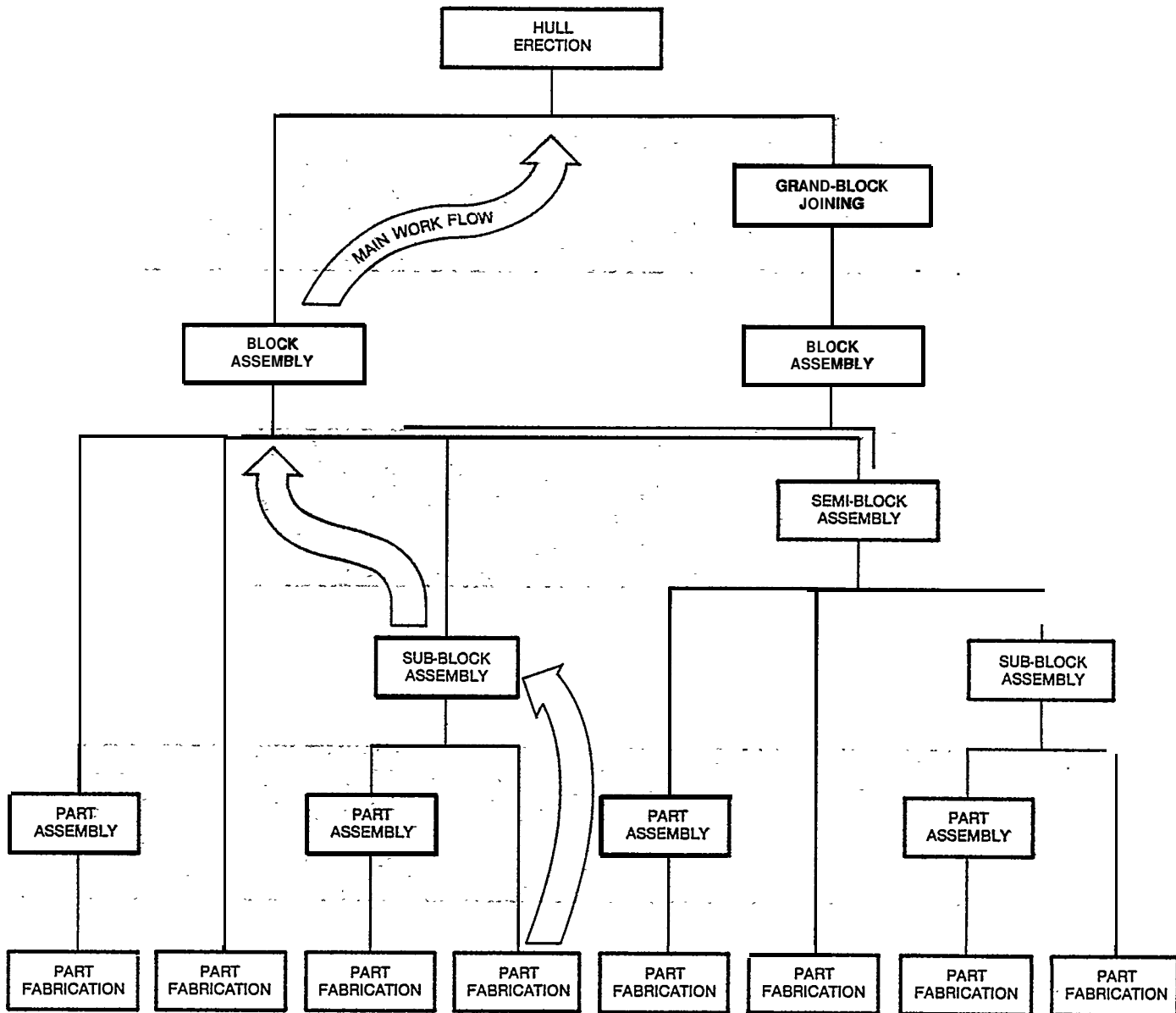
- shifting welding from difficult to down-hand positions in order to reduce the working times needed, and
- distributing much work traditionally performed during block assembly among earlier levels in order to equalize their working times.

For large ships, blocks planned in accordance with the foregoing, should also be of the largest size permitted by facilities. The same planning applied to a smaller ship of the same basic type, quickly achieves nearly the same work balance with the same “game” plan. This is an important competitive advantage. However, pertinent work package contents, working times and interim-product sizes become smaller. Thus, there is sometimes need for an additional manufacturing level for joining blocks into grand blocks.

With regard for these objectives it is practical to plan hull construction in seven levels as shown in Figure 3-1. Starting with the block level, work is subdivided down to the part fabrication level for the purpose of optimizing work flow. In contrast, work assigned to the grand block level serves to minimize the duration required for erection in a building **dock**.

Within each level other than the grand block and hull erection levels, the resulting proposed interim products are examined for similarities in their product aspects. Then, they are grouped by similarities in order to:

- further modularize the production processes,
- justify expensive but highly efficient facilities, and
- achieve manpower savings.



**FIGURE 3-1:** Typical Manufacturing Levels for the Hull Block Construction Method (HBCM). For maximum productivity the main work flow must be uniform. A *manufacturing level* is a combination of work operations which transforms various inputs into distinct interim products, e.g., raw materials into pans, parts into sub-block assemblies, etc. *Astage* as shown in Figure 3-2, is one of a number of work operations within a manufacturing level.



PLAN'G LEVEL	MFG LEVEL	PRODUCT ASPECTS										CODES		
		ZONE		AREA					STAGE			ZONE	AREA	STAGE
1	7	SHIP	FORE HULL	CARGO HOLD	ENGINE ROOM	AFT HULL	SUPERSTRUCTURE	TEST			SHIP. NO.	BLOCK CODE	STAGE CODE	
								ERECTION						
2	6	BLOCK	FLAT PANEL	CURVED PANEL	SUPERSTRUCTURE	BACK PRE-ERECTION		NIL	GRAND-BLOCK CODE	GRAND-BLOCK CODE	STAGE CODE			
						PRE-ERECTION		NIL						
						JOINING		NIL						
3	5	NIL	FLAT	SPECIAL FLAT	CURVED	SPECIAL CURVED	SUPERS' IUC	BACK ASSEMBLY		BLOCK CODE	BLOCK CODE	STAGE CODE		
								ASSEMBLY						
								FRAMING	NIL					
								PLATE JOINING	NIL					
4	4	NIL	SIMILAR SIZE IN A LARGE QUANTITY	SIMILAR SIZE IN A SMALL QUANTITY	BACK ASSEMBLY		NIL	SEMI-BLOCK CODE	SEMI-BLOCK CODE	STAGE CODE				
					ASSEMBLY									
					PLATE JOINING	NIL								
					BACK ASSEMBLY	NIL								
5	3	SUB-BLOCK	NIL			ASSEMBLY		SUB-BLOCK CODE	SUB-BLOCK CODE	STAGE CODE				
						ASSEMBLY								
6	2	SUB-BLOCK	SUB-BLOCK PART	BUILT-UP PART	BENDING		NIL	ASSEMBLED PART CODE	STAGE CODE					
					ASSEMBLY									
7	1	PART	PARALLEL PART FROM PLATE	NON-PARALLEL PART FROM PLATE	INTERNAL PART FROM PLATE	PART FROM ROLLED SHAPE	OTHER	BENDING		NIL	PART CODE	STAGE CODE		
								MARKING & CUTTING						
								PLATE JOINING	NIL					

FIGURE 3-2: Typical classifications of product aspects for the Hull Block Construction Method (HBCM).

Typical groupings by product aspects are presented in Figure 3-2. The horizontal combinations characterize the various types of work packages that are requisite and sufficient for the work to be performed for each level. Vertical combinations of the various types of work packages denote the process lanes for hull construction work flow which correspond to those simply illustrated in Figure 2-4.

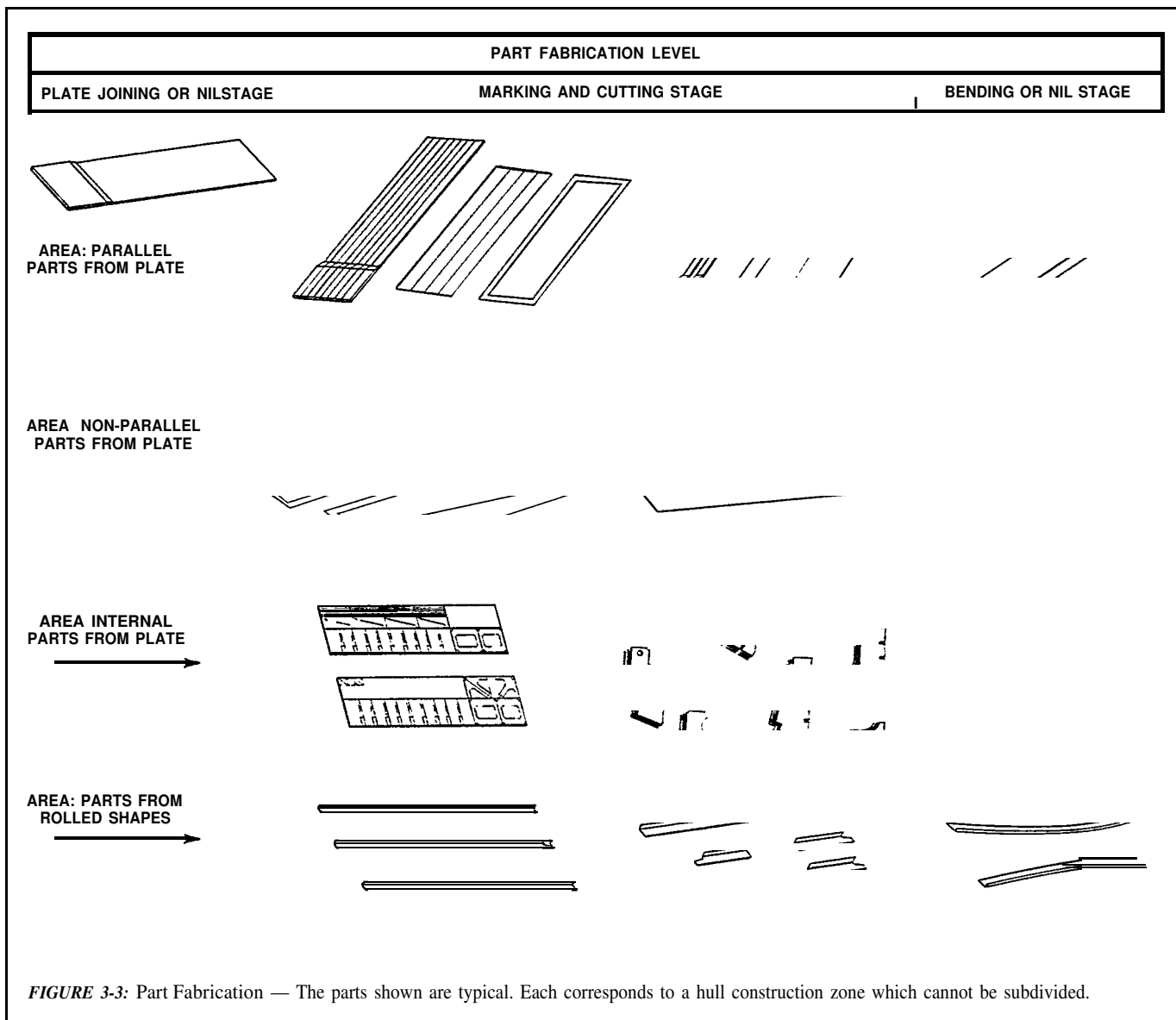
When product resources are allocated, each work package is optimally sized based upon determination of its productivity value (PV). Some reiteration can be expected because grouping by problem area at each level is dependent upon the productivity values achievable. Maximum productivity is obtained when:

- work is evenly allocated to work packages grouped by their product aspects, and
- there are quick responses to potential work unbalance such as shifting workers between manufacturing levels and/or flow lanes, authorizing overtime or even astute short-term schedule changes.

### 3.1.1 Part Fabrication

As shown in Figure 3-2, part fabrication is the first manufacturing level. It produces components or zones for hull construction which cannot be further subdivided. Typical work packages are grouped by zone and:

- by area, for associating raw materials, finished parts, fabrication processes and relevant facilities separately for:
  - parallel parts from plate
  - non-parallel parts from plate
  - internal parts from plate
  - parts from rolled shapes
  - other parts, e.g., from pipe, etc.



- by stage, after having performed groupings by zone, area, and similarities in part types and sizes, as follows:

- plate joining or nil
- marking and cutting
- **bending or nil.**<sup>1</sup>

For large quantities of parts to be bent, problem area can be subdivided by the resources available such as:

- universal press (single-axis shallow curvature)
- press with die (small parts, e.g., bracket flange)
- mechanized line-heating (double-axis shallow curvature)
- manual line-heating (double-axis deep curvature and correction of any part).

A face plate for example, is marked and nested on a plate with other such parts that can be cut in one pass by a multiflame planer. Those which require different curvatures are then grouped together provided they can be processed by a press without need to change dies. Face plates, including those that are to remain straight, are then grouped per block and distributed to succeeding work packages.

Typical groupings of work packages for parts fabrication are illustrated in Figure 3-3.

### 3.1.2 Part Assembly

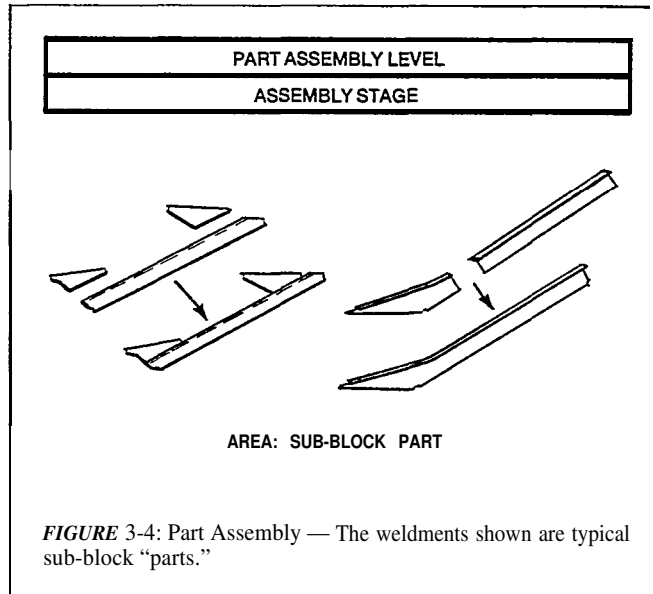
The second manufacturing level is special and outside the main work flow. Its typical work packages are grouped by area as:

- built-up part, e.g., tee- or ci-section longitudinals of large or unusual sections not rolled by mills, and
- sub-block part, e.g., a part which is a weldment, typically consisting of a bracket fitted with a face plate or flat bar, as shown in Figure 3-4.

The sub-block “part” concept is a planning technique for shifting work from the sub-block assembly level, where excessive work volume is otherwise probable, to an earlier level outside the main work flow. Undertaken with simple facilities as compared to those required for sub-block assembly (e.g. mechanized conveyors), manufacturing sub-block “parts” in the part assembly level is a means of balancing work and conserving resources. Further, as such “parts” are only used in sub-blocks, zone identification employs the same code as for sub-blocks; see Figure 3-2.

*Stage* is divided into:

- **assembly**
- bending or nil.



### 3.1.3 Sub-block Assembly

Sub-block Assembly appears in the third manufacturing level of Figures 3-1 and 3-2. A zone is generally a weldment, consisting of a number of fabricated and/or assembled parts, which will eventually be fitted on a panel during block assembly.

Typical work packages are grouped by *area* for:

- similar size in large quantities, e.g., large transverse frames, girders, floors, etc.
- similar size in small quantities.

Subassemblies falling within the first problem area regardless of their design differences can be mass-produced size-by-size on process lanes with appropriate facilities, e.g., conveyors. Those in the second category require a job-shop approach because of:

- insufficient numbers for any one size, and
- different working times required for the different sizes that are normally encountered.

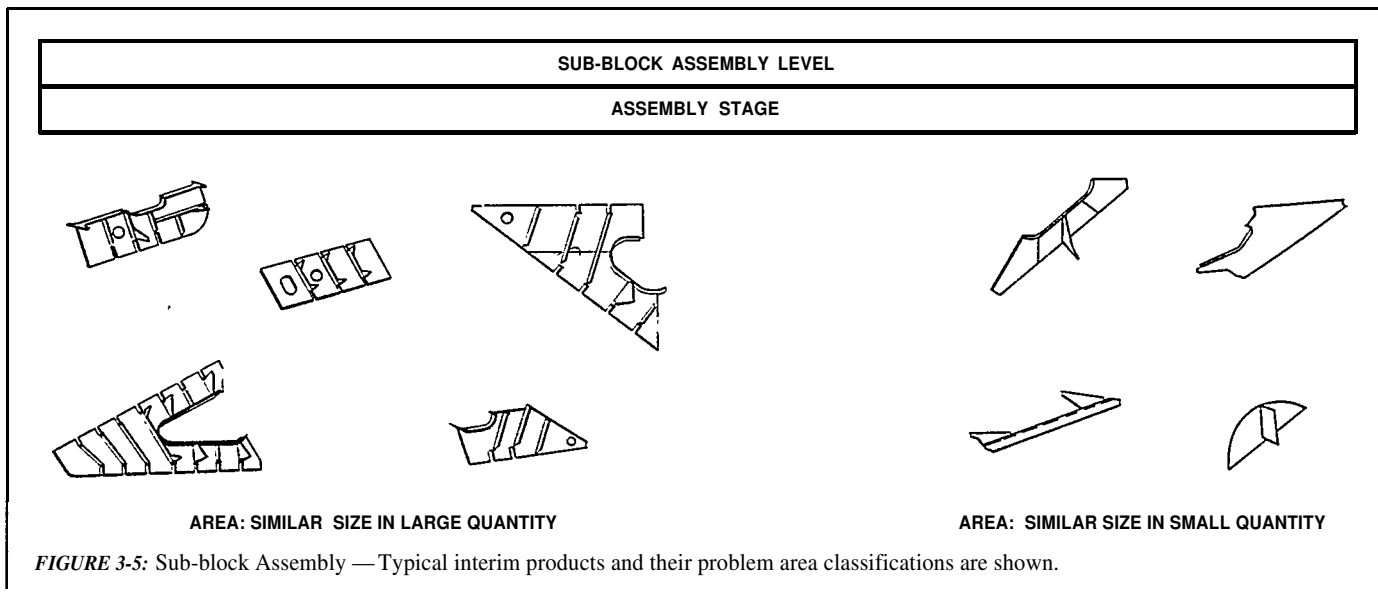
*Stage* classifications are:

- **assembly**
- back assembly or nil.

During *back assembly*, parts and/or assembled parts are fitted on the opposite side of a marked surface of a main part (it is additional fitting after overturning).

Examples are shown in Figure 3-5.

<sup>1</sup>"Nil" means no product aspect exists; thus it is left blank for its categorization and coding and is skipped in a process flow.



### 3.1.4 Semi-block and Block Assembly<sup>2</sup> and Grand-block Joining<sup>3</sup>

A block is the key zone for hull construction and as indicated in Figures 3-1 and 3-2 it may, depending on circumstances, be planned in three assembly levels, i.e.:

- semi-block assembly,
- block assembly, and
- grand-block joining.

Only block assembly is in the main work flow. The other levels provide useful planning alternatives. All are planned in accordance with the concept of grouping work packages by area and stage.

A semi-block serves the need to assemble a partial zone separate from a key zone (block) whenever a block would otherwise disrupt work flow. When a semi-block is employed, the block assembly level is where it joins its “mother” block which was processed in the main work flow.

Grand-block joining, i.e., the combining of a few blocks to create a larger block at a site near a building dock:

- reduces the working time needed for erection in a building dock,
- produces a shape that is more stable for erection purposes, and
- provides more spacious area and volume which facilitates further on-block outfitting and painting.

This level, which is outside the main flow, is needed when zone divisions from a large ship are applied to a small ship in order to quickly achieve a nearly uniform work balance. The ensuing smaller-size blocks are joined into grand blocks in order to minimize the working time needed in a building dock for erection.

The *zone* of the three levels ranges from block to ship as shown in Figure 3-2.

The *semi-block assembly level* is divided by problem *area* in the same manner as for the sub-block level. Most semi-blocks are rather small in size and two dimensional so that they can be produced in a sub-block assembly facility. In planning work, this should be the point of divergence for separating semi-block assembly from block assembly. The grouping by *stage* for semi-blocks is also the same as for sub-blocks as also shown in Figure 3-2.

The *block assembly level* is divided by problem *area* using:

- distinguishing features of the *panel needed* as a base for attaching parts, assembled parts and/or sub-blocks, and
- uniformity of working times required.

These characteristics determine whether:

- platens or pin jigs are required, and whether
- blocks are to be assembled in a flow where work starts and completes in unison.

Because of their uniqueness, superstructure blocks are addressed separately.

<sup>2</sup> “Assembly” means the combining of interim products from any lower levels in order to produce a larger interim product.

<sup>3</sup> “Joining” means to combine only interim products from the previous level in order to produce a larger interim product.

Pertinent problem *area* divisions and necessary definitions are:

- flat (working time is uniform and there are no projections from panel undersides which require special jigs or which would interfere with platens equipped with conveyors)
- special flat (sometimes called semi-flat; working time is non-uniform and/or unique jigs or supports are needed)
- curved (working time is uniform)
- special curved (working time is non-uniform and/or unique jigs or supports are needed)
- superstructure.

Special-flat and special-curved blocks, because of variations in working times and/or needed jigs, are not assembled in facilities designed for work flow where starts and completions are in unison. Thus, they require a job-shop approach.

If the quantity of blocks to be produced is small, less than five problem area classifications should be considered. Typical classifications by problem area are illustrated in Figure 3-6.

As shown in Figure 3-2, the block assembly level is phased by *stage* as follows:

- plate joining or nil
- framing or nil
- assembly
- back assembly or nil.

The assembly stage at the block level is for combining a panel with parts, assembled parts and/or sub-blocks and sometimes a semi-block. When many blocks are required it could be useful to add further classifications by problem *area* based upon internal framing, i.e.,

- egg box
- longitudinals attached before webs
- longitudinals attached after webs
- other.

At the *grand-block joining level* only three classifications by *area* are normally required:

- flat panel
- curved panel
- superstructure.

*Stage* at this level is subdivided into:

- joining or nil
- pre-erection or nil
- back pre-erection or nil.

For very small ships, the pre-erection stage provides for joining grand blocks in order to create grand-grand blocks. Back pre-erection provides for further assembly work after turnover, e.g., attaching bulwarks, chain pipes, etc.

Figures 3-7 through 3-17 show relationships between semi-blocks, blocks and grand blocks that were actually employed for construction of a 22,000 deadweight-ton general-cargo carrier. It was purposely selected as the basis for illustration because it is one of a type, i.e., it was not a ship of a standard series.

### 3.1.5 Hull Erection

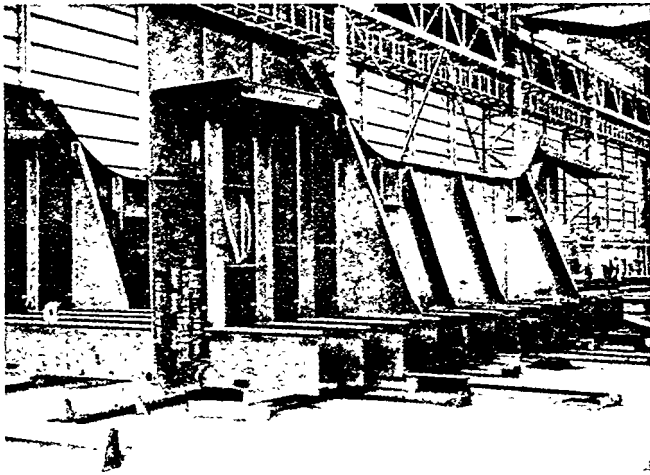
Erection is the final level of the hull construction where the entire hull is the *zone*. Problem *areas* at this level are:

- fore hull
- cargo hold
- engine room
- aft hull
- superstructure.

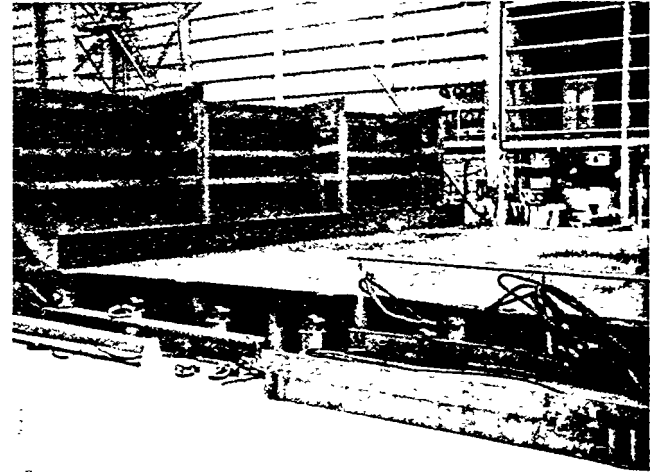
*Stage* is simply divided into:

- erection
- test.

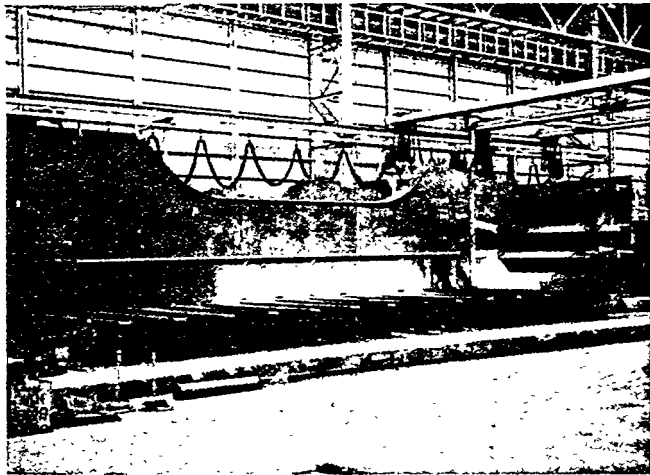
Tests at this level, such as tank tests, are independent of erection and are distinguished by the size of their work packages as compared with the tests and inspections of other levels. The latter tests and inspections are included in the packages of each level and respectively implemented at the time when each interim product is being finished.



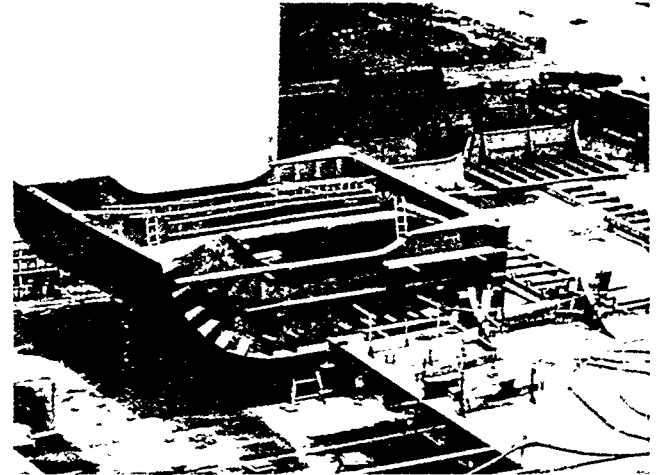
A. AREA: FLAT  
STAGE: FRAMING (EGG BOX)



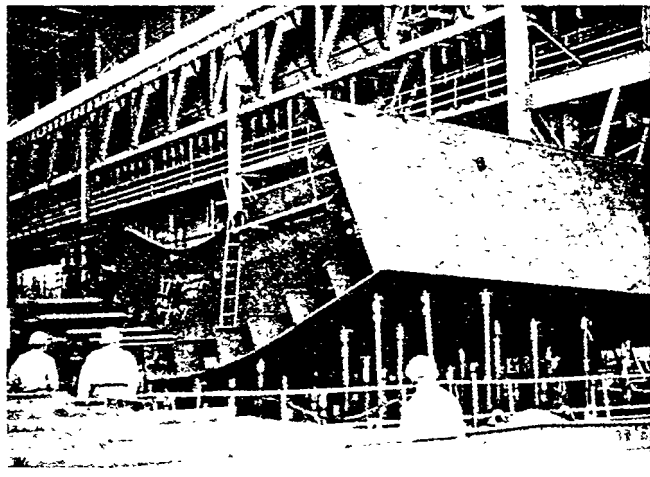
B. AREA: FLAT  
STAGE: ASSEMBLY (STARTING)



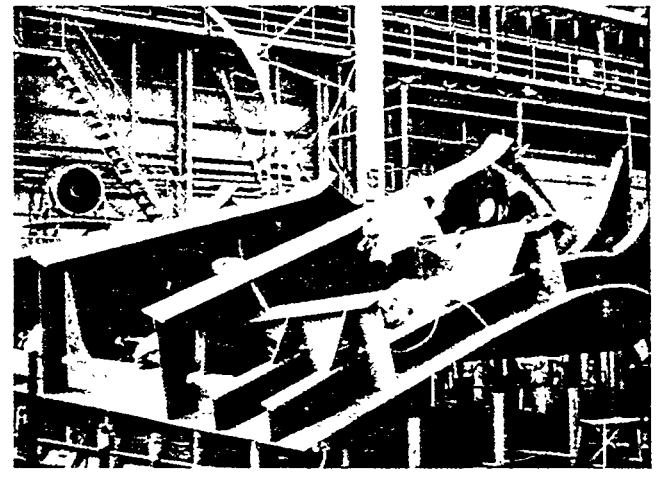
C. AREA: FLAT  
STAGE: ASSEMBLY (COMPLETING)



D. AREA: SPECIAL FLAT (NON-UNIFORM WORK CONTENT)  
STAGE: ASSEMBLY (OFF FLOW)



E. AREA: CURVED  
STAG: ASSEMBLY



F. AREA SPECIAL CURVED (NON-UNIFORM WORK CONTENT)  
STAGE ASSEMBLY (OFF FLOW)

FIGURE 3-6 Block Assembly Level — Typical problem area and stage classifications.

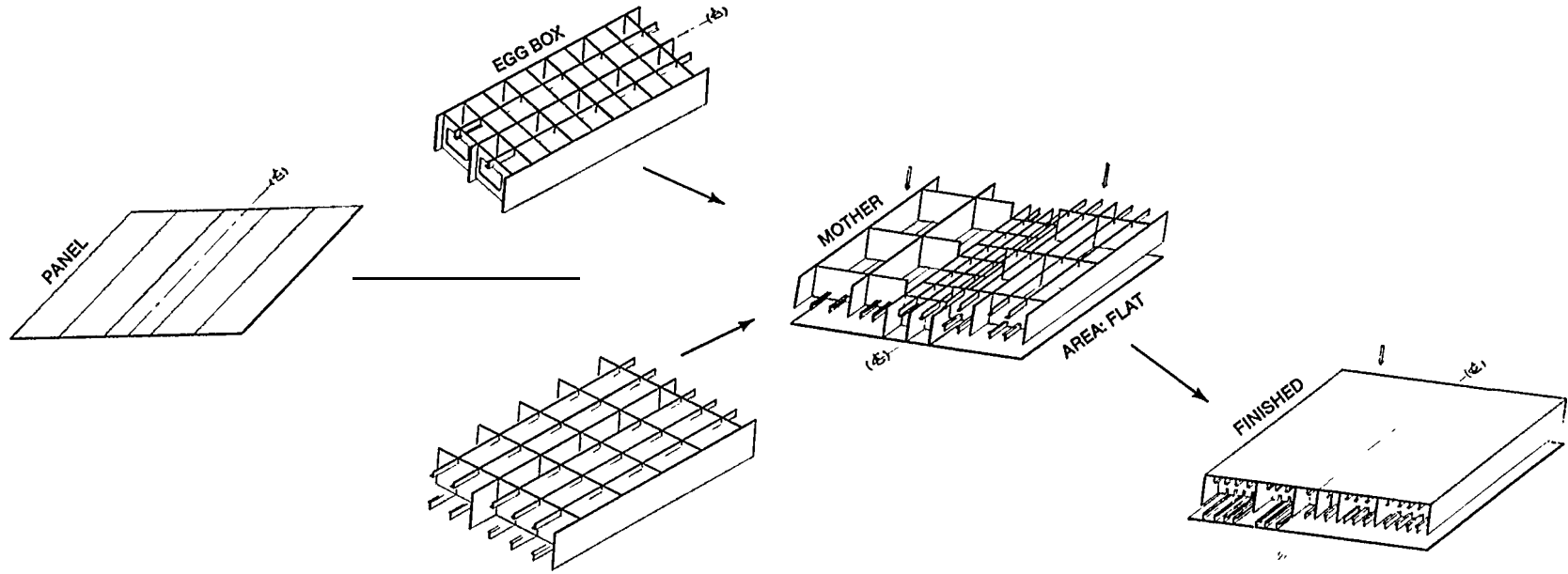
BLOCK ASSEMBLY LEVEL

PLATE JOINING STAGE

FRAMING STAGE

ASSEMBLY STAGE

BACK ASSEMBLY STAGE



SEMI-BLOCK ASSEMBLY LEVEL

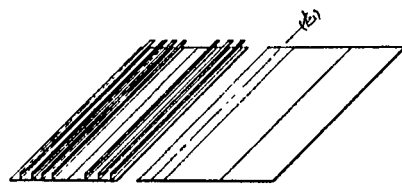
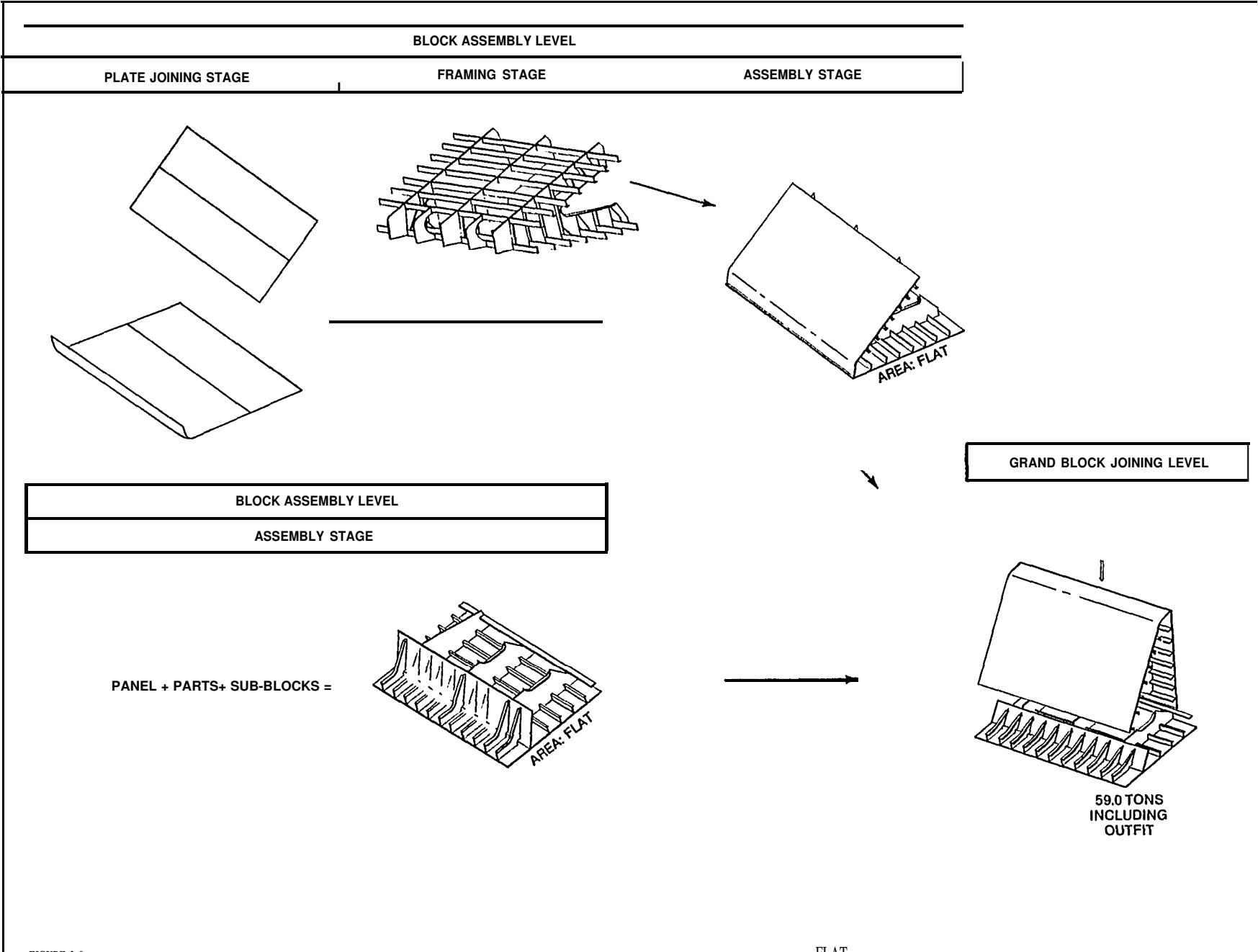


FIGURE 3-7: Semi-block and Block Assembly — Bottom Center Block of Cargo Hold. Work block could progress in a uniform work flow. The problem area classification is FLAT.

of the finished block exceeds norm.

was designated so that work for the mother





SEMI-BLOCK ASSEMBLY LEVEL  
ASSEMBLY STAGE

BLOCK ASSEMBLY LEVEL  
ASSEMBLY STAGE

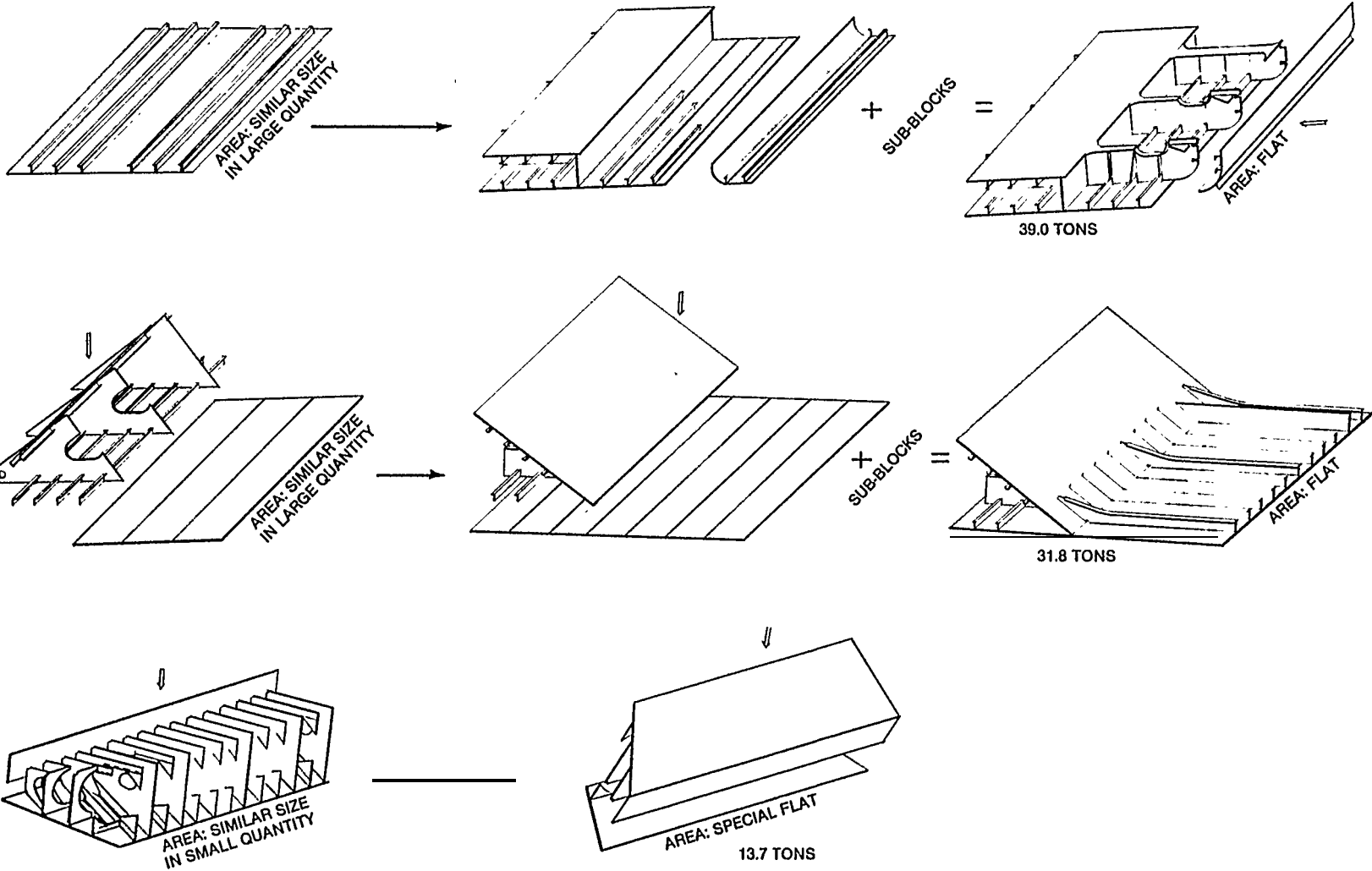
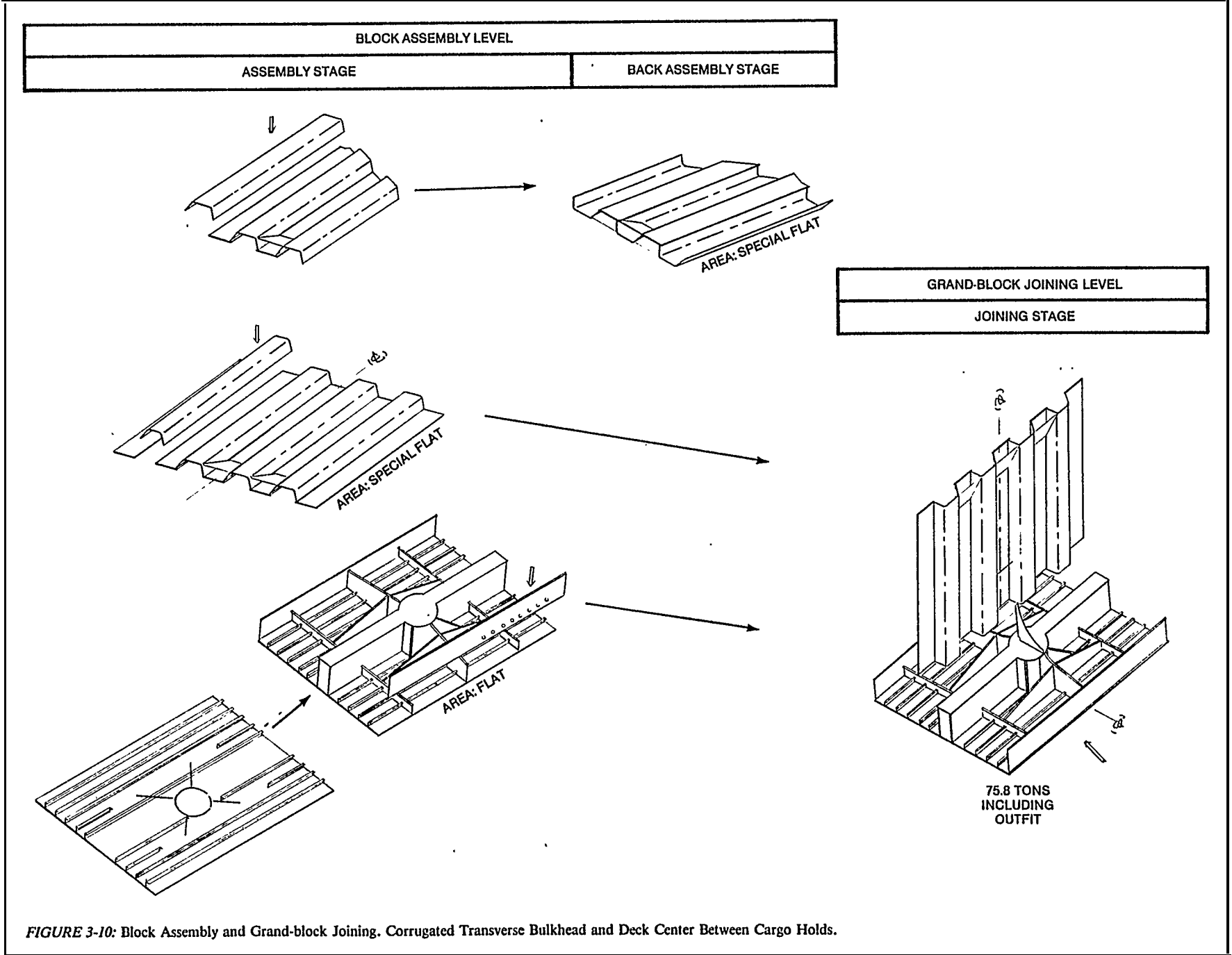
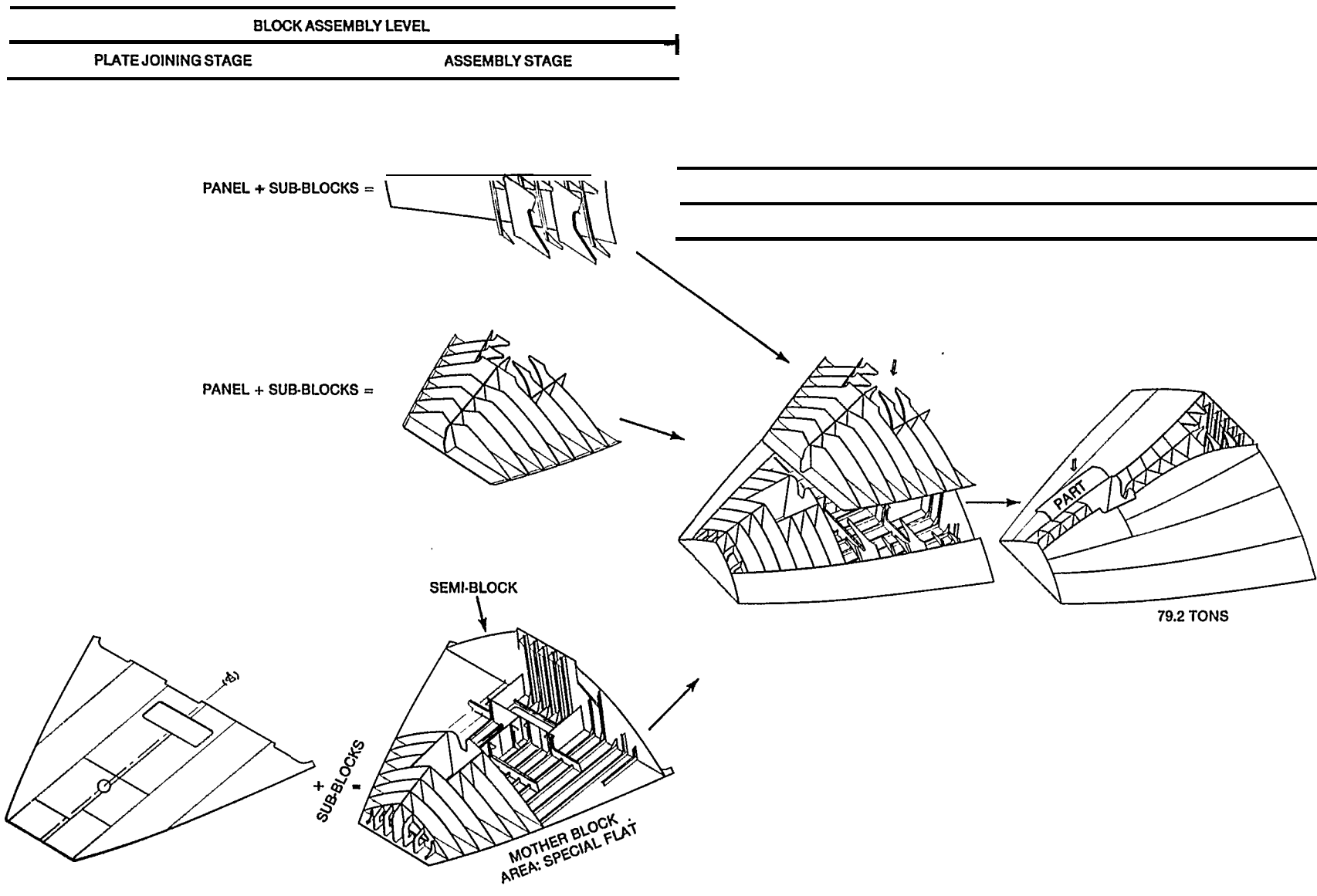


FIGURE 3-9: Semi-block and Block Assembly — Bottom Wing, Side Shell with Hopper, and Transverse Hopper in Cargo Hold. Problem area classifications SIMILAR SIZE IN LARGE QUANTITY and FLAT designate work for assembly lines (on-flow). SIMILAR SIZE IN SMALL QUANTITY and SPECIAL FLAT designate job-by-job work (off flow) because there are too few of them or because their work content is not uniform.



**FIGURE 3-10: Block Assembly and Grand-block Joining. Corrugated Transverse Bulkhead and Deck Center Between Cargo Holds.**



**FIGURE 3-11: Block Assembly and Grand-block Joining — Cant Block.** Attaching a semi-block to a mother block which is classified by area as **SPECIAL FLAT** is an exception. Also, providing for a part during grand-block joining is planned as an exception.

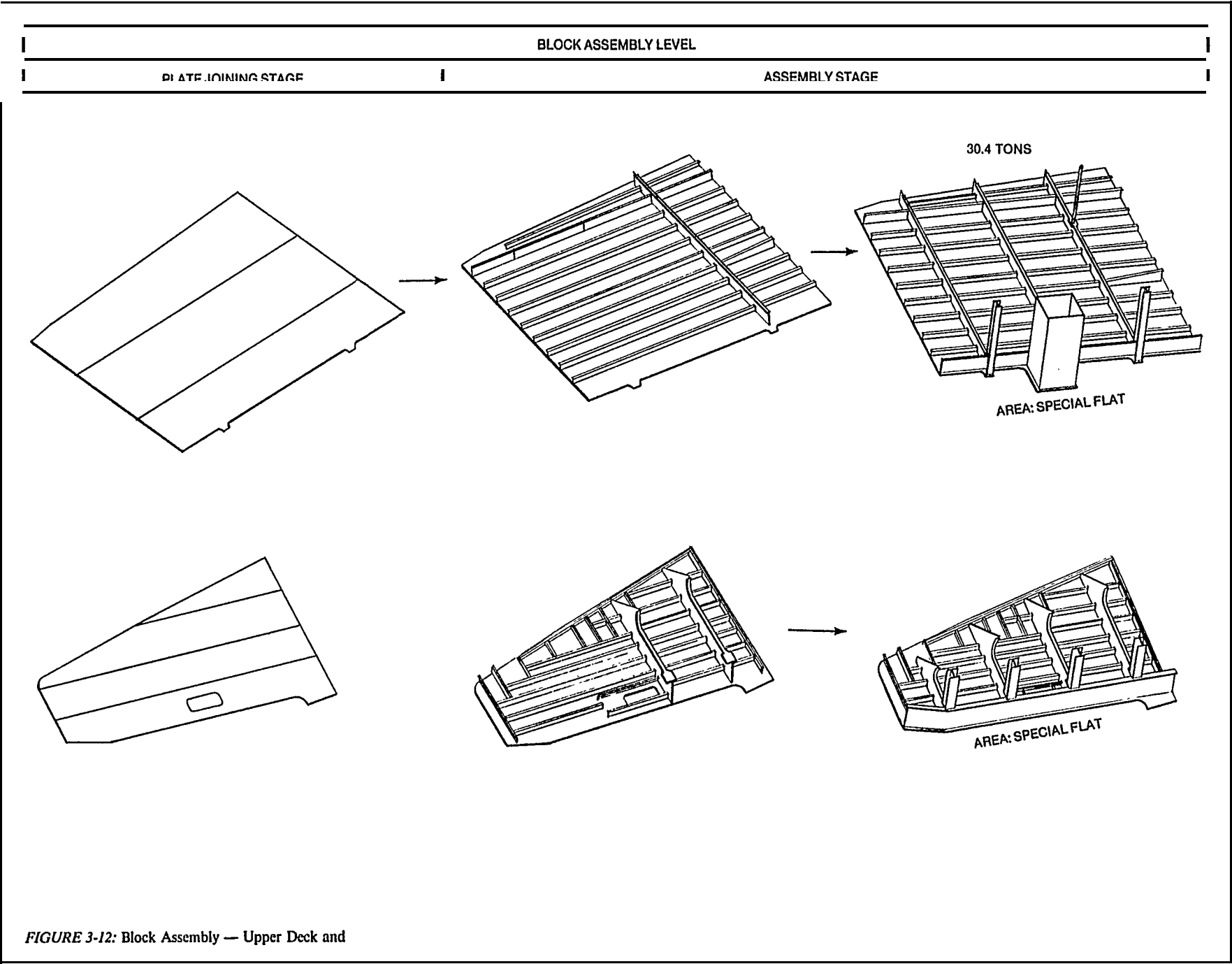
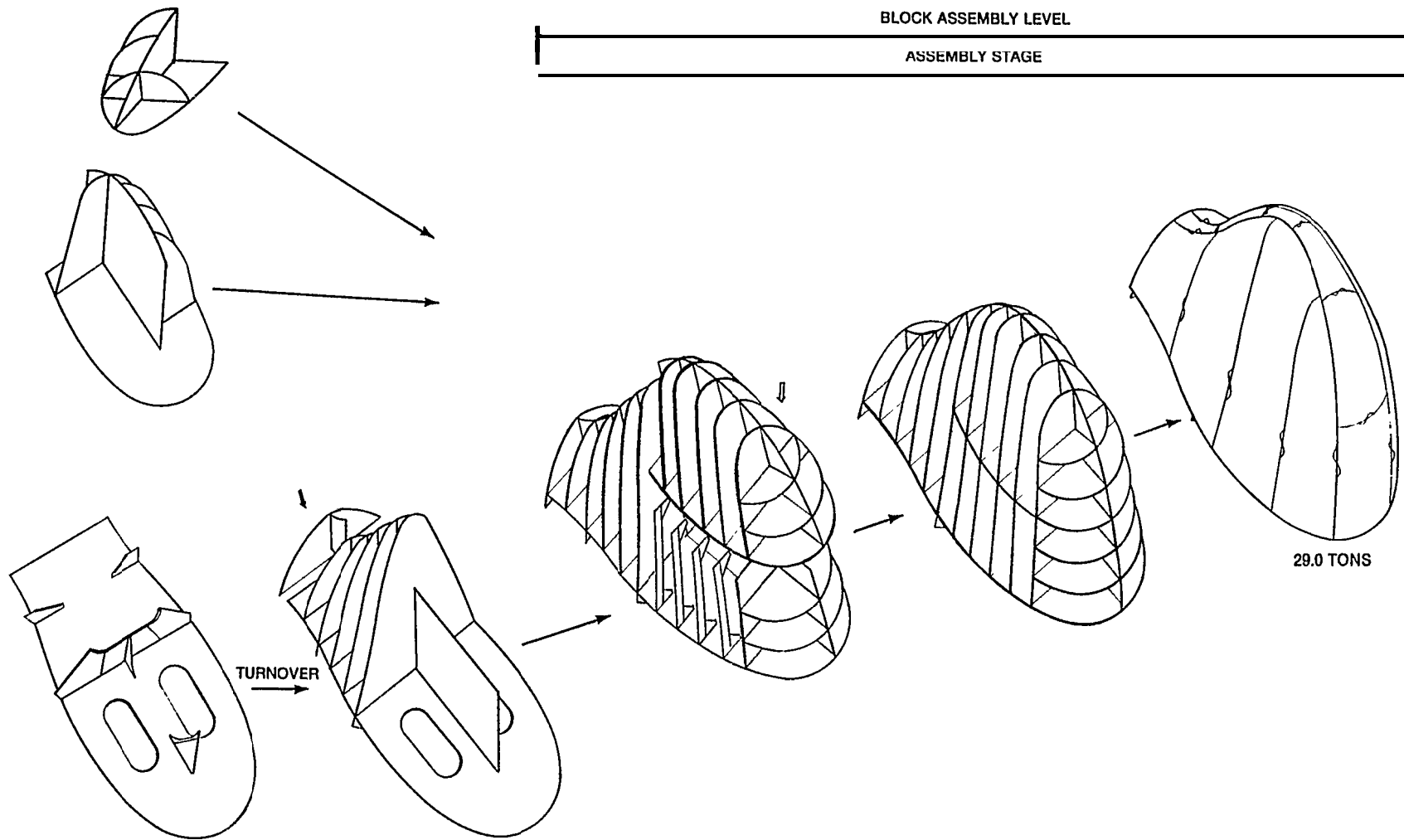


FIGURE 3-12: Block Assembly — Upper Deck and

SEMI-BLOCK ASSEMBLY LEVEL	
ASSEMBLY STAGE	BACK-ASSEMBLY STAGE

BLOCK ASSEMBLY LEVEL	
ASSEMBLY STAGE	



**FIGURE 3-13: Semi-block and Block Assembly – Bulbous Bow.** The three semi-blocks are classified by problem area as **SIMILAR** IN SMALL QUANTITY. The block, regardless of its work content, is classified as **SPECIAL FLAT** because the projections beneath require that it be assembled on a special jig.

SEMI-BLOCK ASSEMBLY LEVEL

BLOCK ASSEMBLY LEVEL

PLATE JOINING STAGE

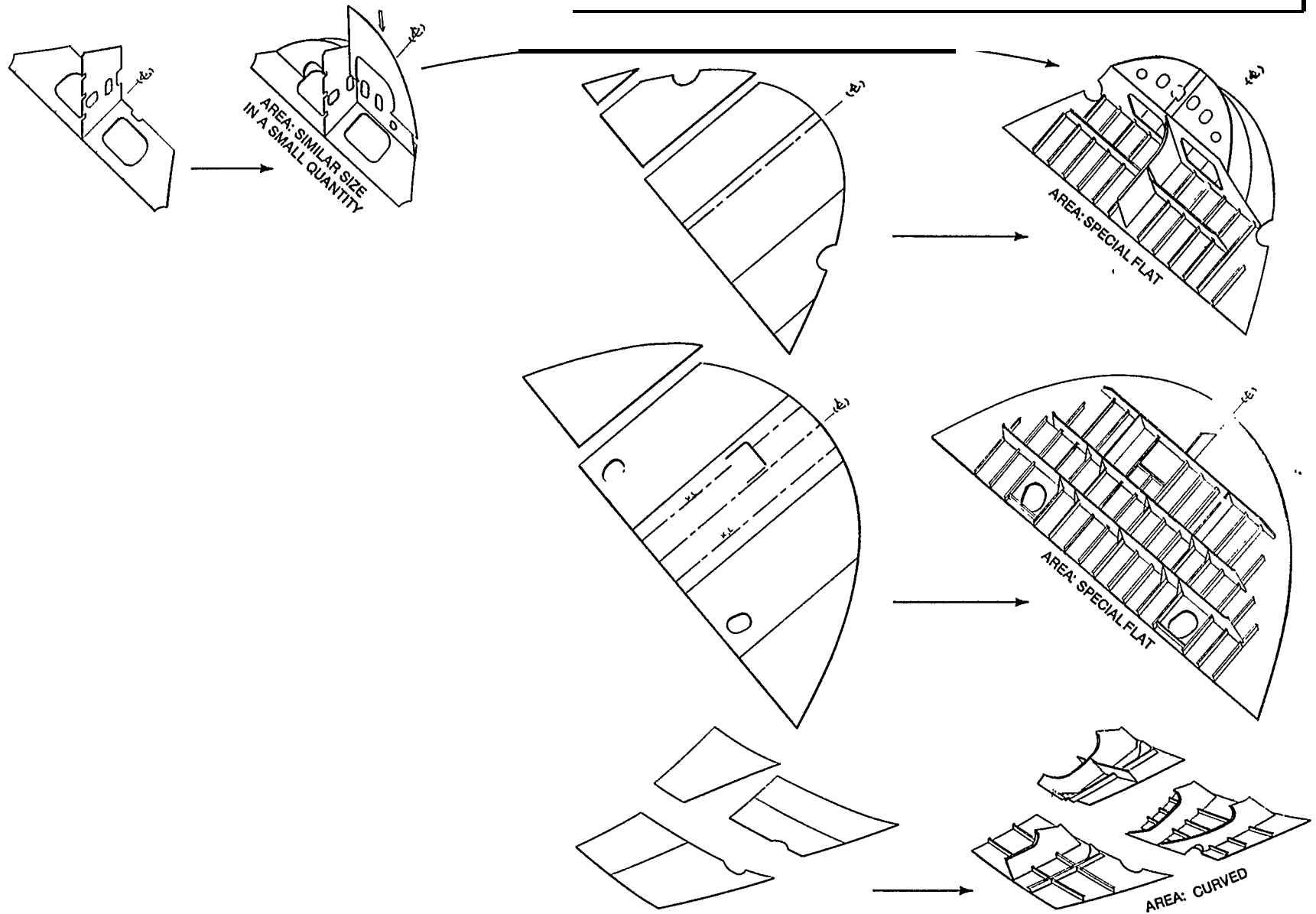
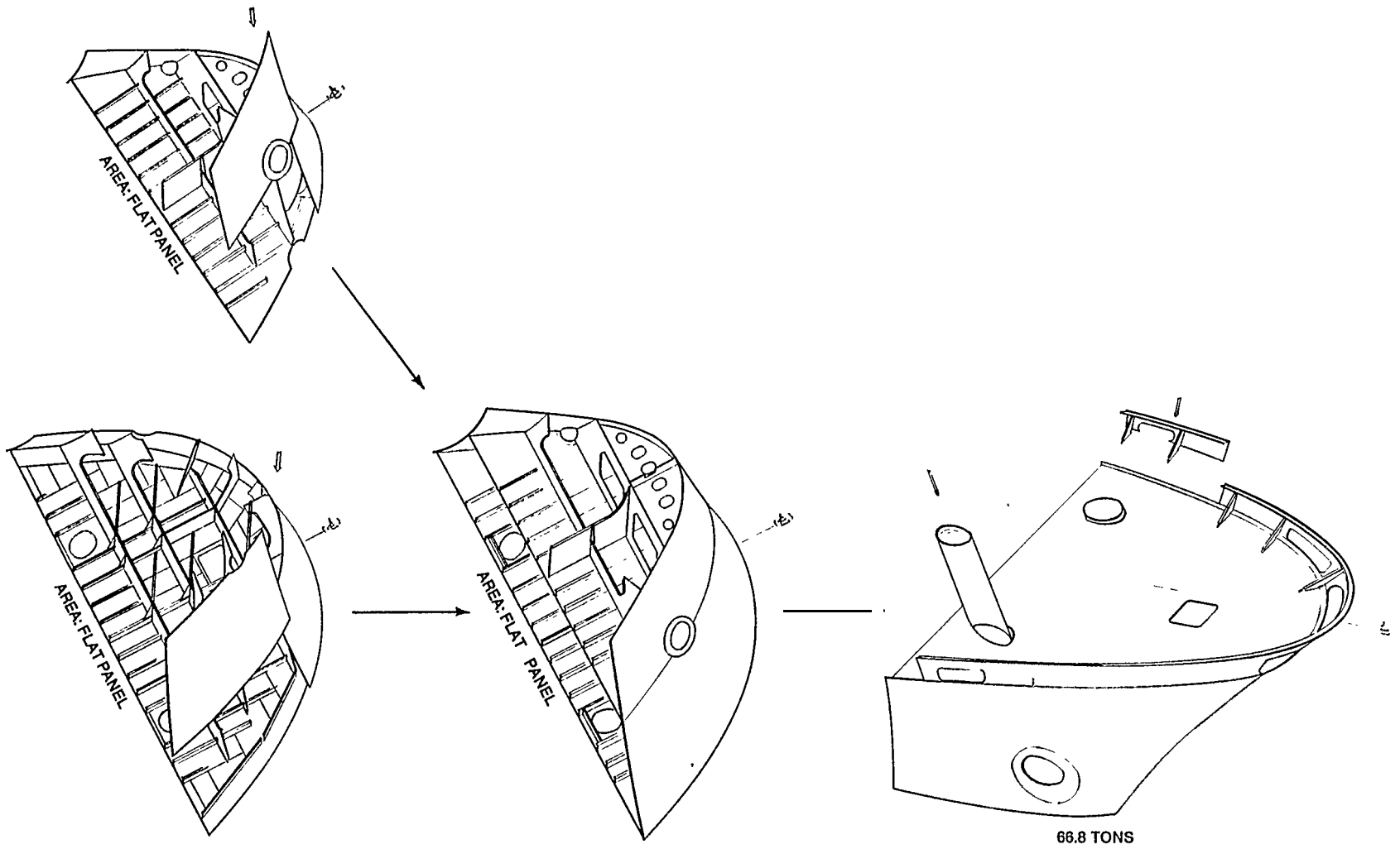
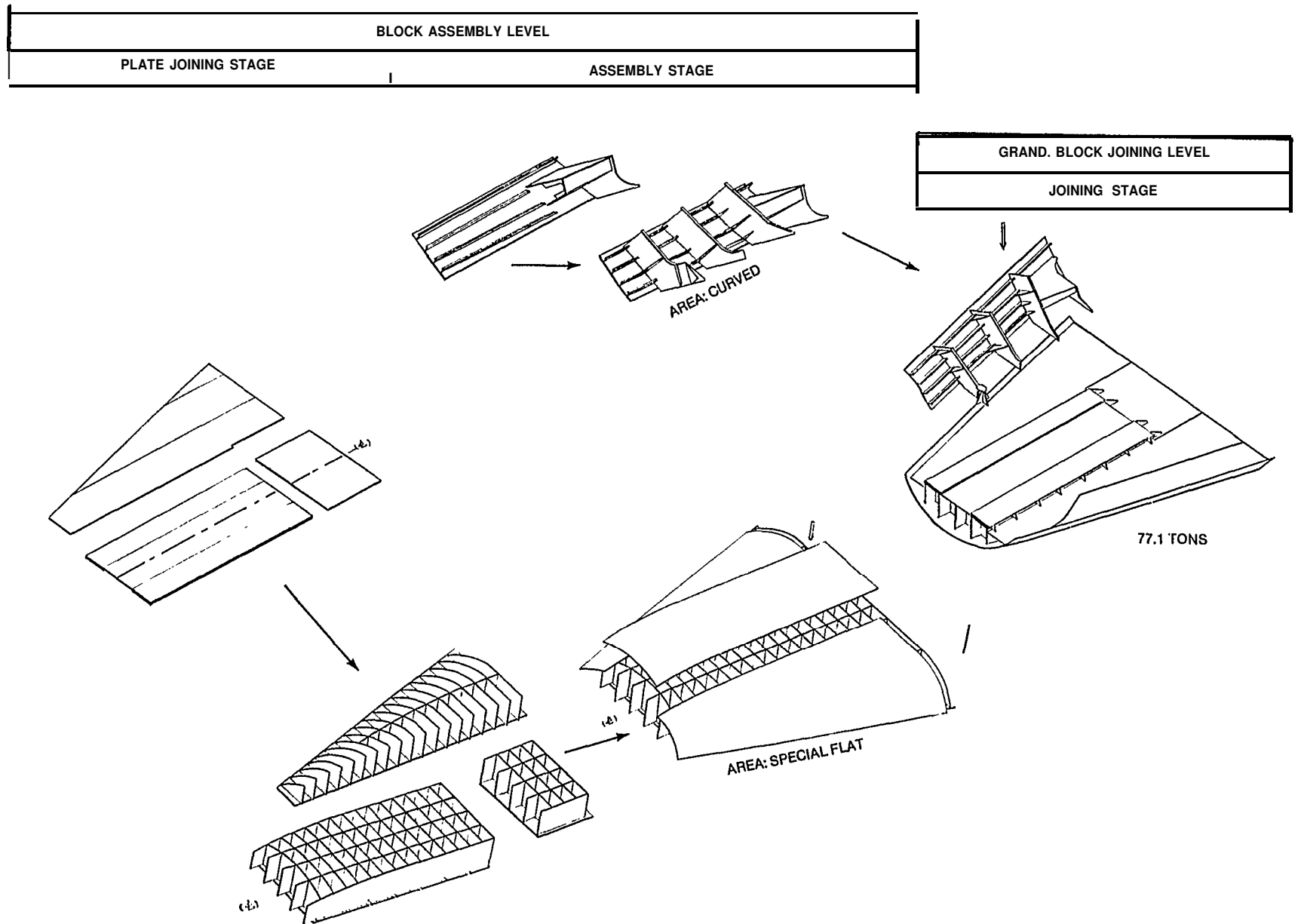


FIGURE 3-14: Semi-block and Block Assembly — Fo'c'sle and Upper Deck of Fore-body.

	RA	LOC	EV
JOINING STAGE	PRE-ERECTION STAGE		BACK PRE-ERECTION STAGE



**FIGURE 3-15:** Grand-block Joining — Fo'c'sle and Upper Deck of Fore-body.



**FIGURE 316:** Block Assembly and Grand-block Joining — Bottom of Engine Room, The engine-room bottom block is classified by area as SPECIAL FLAT because of its work content and the projection of the main-engine foundation.



BLOCK ASSEMBLY LEVEL

ASSEMBLY STAGE

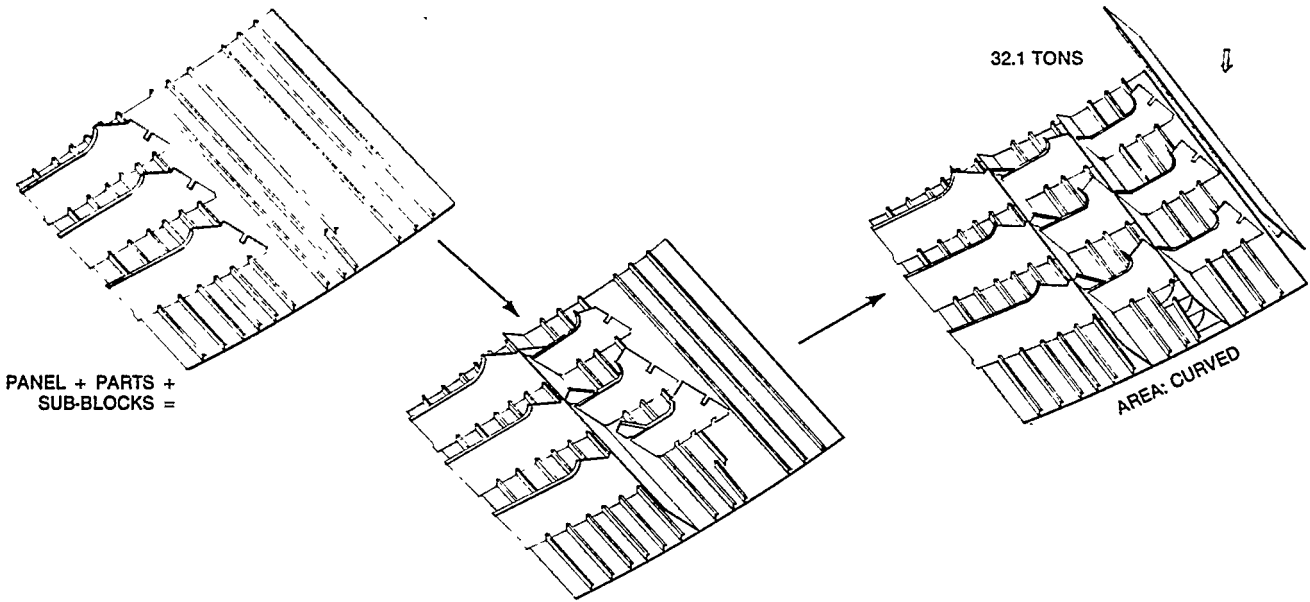


FIGURE 3-17: Block Assembly — Side Shell of Engine Room.



### 3.2 Zone Outfitting Method

The Zone Outfitting Method (ZOFM) is a natural consequence of the Hull Block Construction Method (HBCM) because both employ the same logic. Shipyards which employ ZOFM assemble most outfit components independent of or on hull blocks.

Just as for hull construction, zone divisions from a similar previously-built ship are tailored to fit a new contract design. The coded significance in work package numbers remains essentially unchanged. Thus, everyone involved in design, material definition, procurement, fabrication and assembly, has knowledge of how outfitting is to progress.

#### 3.2.1 Zone by Area by Stage

HBCM planners define interim products starting with a hull as a zone, thence subdividing it into block zones which in turn are divided into sub-block zones and so on. The process is completed when zones are defined that cannot be further subdivided, i.e., zones which correspond to parts. The nature of any of these zones associates it with a specific manufacturing level. This regimentation is natural for hull construction but not so for outfitting.

ZOFM planners have to consider, even participate in devising, block zones for hull construction. Elsewhere, they should be free to devise zones which best suit the work at hand. Their outfit zones at one manufacturing level can be independent of zones in previous or succeeding levels. For example, in hull construction zone sizes increase as manufacturing progresses. Whereas outfitting zones at earlier stages, for control purposes, could be larger and have no common boundaries with zones defined for subsequent stages. Overlapping zones are of no consequence provided they are designated for different stages. Thus, while there is greater freedom in defining outfit zones, specifying **zone by area by stage** affords absolute control of work even in a **confined region that contains portions of many systems.**<sup>4</sup>

#### 3.2.2 On-unit, On-block and On-board Outfitting

**On-unit** refers to a zone which defines an arrangement of fittings to be assembled in-house independent of hull structure. Assembly of such fittings is called outfitting on-unit. It enhances safety and reduces both required manhours and durations which would otherwise be allocated to outfitting on-block and on-board.

**On-block** for outfitting purposes refers to a rather flexible relationship between block and zone. The assembly of fittings on any structural subassembly, (e.g., semi-blocks, blocks and grand blocks) is referred to as outfitting on-block. The zone applies to that region being outfitted. The fitting arrangement on the ceiling of a block set upside down is a zone. Following block turnover, the fitting arrangement on deck is another zone.

**On-board**, is a division or zone for packaging work for the assembly of fittings during hull erection and subsequent to launching. An ideal zone for outfitting on-board avoids the need to disperse and/or continuously relocate resources, particularly workers. In general, compartments defined by shell, bulkhead, deck, or other partitions are suitable. Even entire cargo holds, tanks, engine rooms, superstructure decks, or weather decks can be useful zones for final outfitting on-board stages.

ZOFM planners addressing the need to breakdown outfit work into packages:

- first, consider outfit components for all systems in an on-board zone and try to maximize the amount fitted into on-block zones, and
- next, consider outfit components for all systems in an on-block zone and try to maximize the amount fitted into on-unit zones.

Their objective is to minimize outfit work during and after hull erection.

As in HBCM, maximum productivity is achieved when:

- work is equally apportioned to work packages grouped by product aspects at all manufacturing levels, and
- uniform and coordinated work flows are maintained by shifting workers, overtime and/or short-term schedule adjustments.

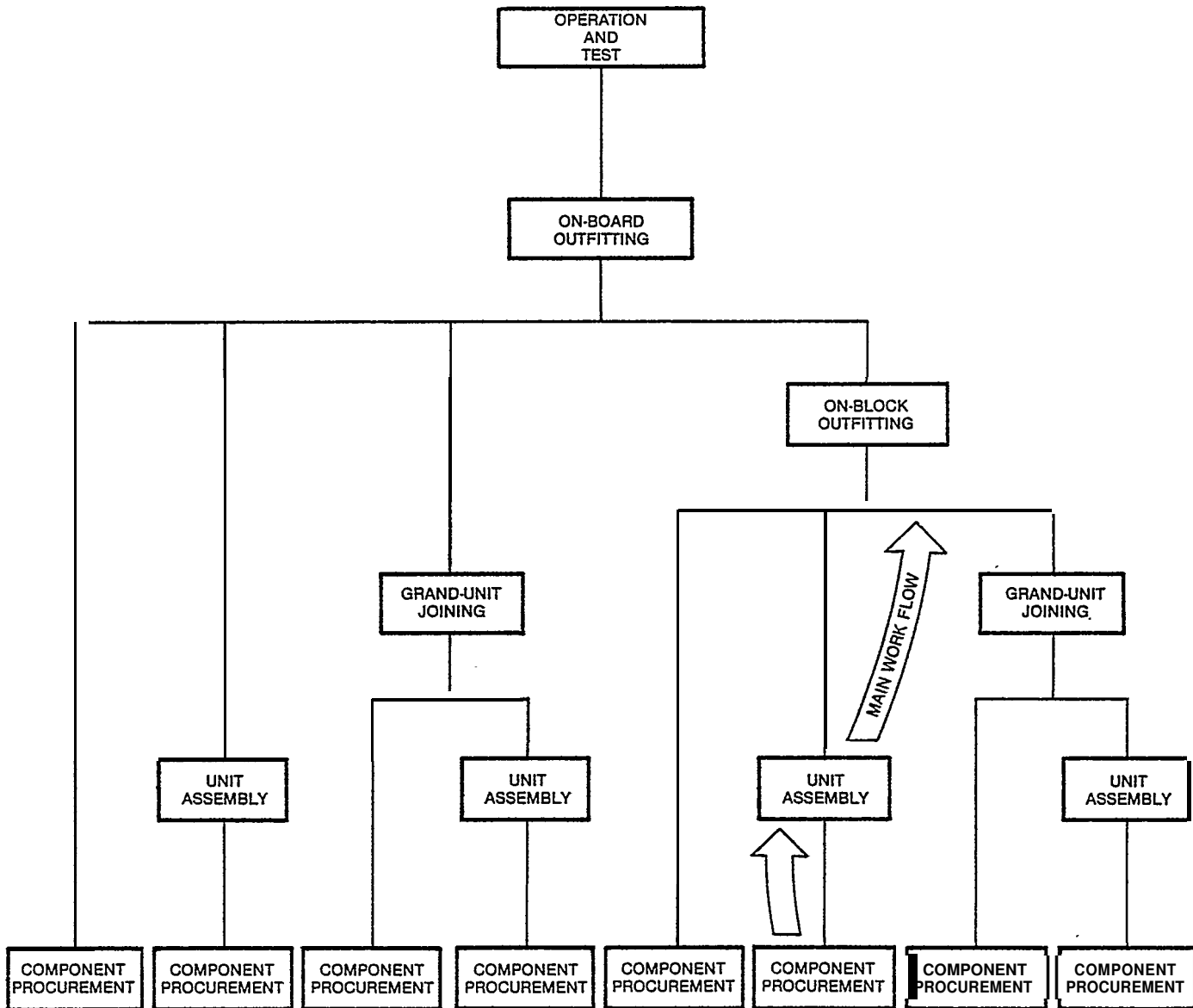
Work packages are optimally sized when their work contents are nearly uniform. The balancing of work among packages requires consideration of groups of components by the product aspects: **zone, area** and **stage**. This balancing of work strongly affects other factors, such as, the allocation of manpower and scheduling.

Other important objectives of ZOFM planners include:

- shifting fitting work, especially welding, from difficult positions to easier down hand positions thus reducing both the man-hours needed and the durations required,
- selecting and designing components so as to organize groups of fittings that can be assembled on-unit, i.e., independent of hull structure, thus simplifying planning and scheduling by keeping the different types of work separate at the earliest manufacturing levels,
- transferring work from enclosed, narrow, high or otherwise unsafe locations to open, spacious and low places thus maximizing safety and access for material handling, and

---

In IHI shipyards the word "pallet" is used to designate a zone per area per stage. Pallets sequenced in their order for execution comprise the outfitting "game" Plan. Adapting a pallet list from a previously instructed ship avoids much "reinvention-of-the-wheel." It is a singular means for shipyard managers to control the application of prior experience as compared to dependence upon experiences vested in design, material and production people acting independently. Further, the unqualified success of zone by area by stage control of outfitting introduces the prospect of significant cost savings if PWBS is applied to very large ship repair or conversion projects.



**FIGURE 3-18:** Typical Manufacturing Levels for the Zone Outfitting Method (ZOFM). For maximum productivity the main work flow should be uniform.

PLAN LEVEL	M'FG LEVEL	PRODUCT ASPECTS								
		ZONE	AREA			STAGE				
1	6	SHIP	DECK	ACCOMMODATION	MACHINERY	ELECTRICAL	OPERATION AND TEST			
2	5	ON-BOARD DIVISION	NIL	SPECIALTY/SIMILAR WORK IN SMALL VOLUME	SPECIALTY/SIMILAR WORK IN LARGE VOLUME	SPECIALTY/SIMILAR WORK BY HIGH SKILL	WELDING	NIL		
							ON-CLOSED-SPACE FITTING			
							WELDING	NIL		
							ON-OPEN-SPACE FITTING			
3	4	BLOCK	NIL	SPECIALTY/COMPONENTS IN A LARGE QUANTITY	SPECIALTY/COMPONENTS IN A SMALL QUANTITY	NIL	WELDING	NIL		
							ON-FLOOR FITTING			
				NIL	LARGE-SIZE UNIT	NIL	SMALL-SIZE UNIT	NIL	WELDING	NIL
									ON-CEILING FITTING	
4	3	UNIT	NIL	LARGE-SIZE UNIT	SMALL-SIZE UNIT	NIL	WELDING	NIL		
							JOINING			
5	2	UNIT	NIL	LARGE-SIZE UNIT	SMALL-SIZE UNIT	NIL	WELDING	NIL		
							ASSEMBLY			
6	1	COMPONENT	NIL	IN-HOUSE MANUFACTURING	OUTSIDE MANUFACTURING	PURCHASING	PALLETIZING			
				MANUFACTURING		NIL				
				DESIGN AND MATERIAL PREPARATION		NIL				

ZONE	AREA	STAGE
SHIP NO.	SHIP NO.	OPERATION CODE
OUTFITTING SIGN/ ON-BOARD ORIGINAL CODE		HULL ERECTION STAGE CODE
OUTFITTING SIGN/ BLOCK CODE	ON-BOARD WORK TYPE CODE	BLOCK ASSEMBLY STAGE CODE
UNIT ASSEMBLY SIGN/BLOCK OR ON-BOARD DIVISION OR MACHINERY UNIT CODE	BLOCK OR ON-BOARD DIVISION OR MACHINERY UNIT CODE	GRAND-UNIT SIGN
COMPONENT CODE/ PALLET CODE		UNIT SIGN
COMPONENT PROCUREMENT SIGN		NO SIGN

FIGURE 3-19: Typical classifications of product aspects for the Zone Outfitting Method (ZOFM). "Specialty" designates deck, accommodation, machinery or electrical.

- planning simultaneous execution of many work packages thus decreasing the overall fitting duration.

Considering these requirements it is practical to plan outfitting in six manufacturing levels as shown in Figure 3-18. The component, unit and grand unit levels are executed independent of the hull structural zones they will eventually be fitted in. The on-block and on-board levels are, of course, entirely dependent on structural entities.

In order to minimize the impact of these dependencies, fitting components should be assembled into units and grand units as much as possible provided that they are truly independent, i.e., rigid and stable without extraordinary temporary reinforcements or supports. This approach is the primary means for shortening the durations required for on-block and on-board outfitting.

Within each level other than that for grand units, the resulting proposed interim products are examined for similarities in their product aspects. Then, as in the HBCM, they are grouped by similarities in order to:

- further modularize the production process,
- justify expensive but highly efficient facilities, and
- achieve manpower savings.

Typical groupings by product aspects are shown in Figure 3-19. Horizontal combinations characterize the various types of work packages that are requisite and sufficient for the work to be performed for each level. Vertical combinations of the various work package types denote the process lanes for outfitting work flow which correspond to those simply illustrated in Figure 2-4.

As the implementation of ZOFM progresses, the need becomes greater for balanced planning and scheduling and cooperation between hull construction, outfitting and painting planners.

### 3.2.3 Component Procurement

As shown in Figures 3-18 and 3-19, component procurement is the initial manufacturing level. It produces interim products or zones for outfitting for which no further subdivision is needed by the shipyard. Typical work packages and material requisitions are grouped by zone and by *area* to address the separate procurement problems, i.e.,

- in-house manufacturing
- outside manufacturing
- purchasing.

These problem areas are - further classified by requirements for manufacturing drawings, purchase order specifications and raw materials as shown in Figure 3-20.

After having performed groupings by zone, area and similarities in component types and sizes, further grouping is made by *stage* as follows:

- design and material preparation or nil
- manufacturing or nil
- palletizing.

The palletized components are assigned to their respective work packages for subsequent manufacturing levels.

### 3.2.4 Unit Assembly and Grand-unit Joining

Just as a block is a key zone for hull construction, a unit is a key *zone* for outfitting which, as illustrated in Figures 3-18 and 3-19, may only require a single manufacturing level. Productivity is enhanced when units are planned which have similarities in working hours needed for assembly, numbers of components, volume, weight, design standards, etc. Grouping by such similarities facilitate organizing and uniformly loading process flow lanes.

AREA	AREA SUBDIVISIONS	
	DESIGN TO FURNISH	MATERIAL TO BE FURNISHED
IN-HOUSE MANUFACTURING	MANUFACTURING DRAWING	YES
OUTSIDE MANUFACTURING	MANUFACTURING DRAWING	YES/NO
PURCHASING	PURCHASE ORDER SPECIFICATION	SELDOM/NO

**FIGURE 3-20.** Problem *area* subdivisions for design and material preparations. When preparations for outside manufacturing are the same as for in-house, a shipyard retains much control, avoids "vendor" drawing approvals and makes eligible many small firms who do not have design or purchasing departments.

As indicated in Figure 3-21, unit sizes vary significantly. Therefore two problem areas are designated at the unit assembly level, i.e.:

- large size
- **small size.**

The distinction is by lift capacity, e.g., units that weigh more or less than one ton. If many small units are planned for assembly of larger units, another manufacturing level may be included for sub-unit assembly.

Problem areas at the unit level, could be further subdivided into:

- machinery unit (machinery combined with all adjacent components including foundation, pipe pieces, valves, supports, walkways, ladders, etc.)
- pipe unit (no machinery, just pipe pieces combined with valves, supports, walkways, etc.), and
- other (hatch covers with coaming, masts, etc.)

*Stage* for unit assembly is divided as:

- assembly
- welding or nil.

The welding stage applies when extensive or special welding requirements exist as welding incident to routine unit assembly is performed by fitters during the preceding **assembly stage.**

Competitive shipyards have developed machinery units into standard arrangements which are often adapted for various types and sizes of ships. As required design and material definition is already available, much planning for a standard machinery unit can progress just as if it was a single component. A typical standard machinery unit is shown in Figure 3-22. Pipe units are generally unique because they reflect the pipe passages and details peculiar to each type and/or size ship even among standard series ships **that are for different owners.**<sup>5</sup>

A variety of units are shown in Figures 3-23 through 3-26.

The **grand unit joining level** primarily provides for combining two or more units in order to:

- reduce the working times needed for fitting on-block and on-board, and
- produce more stable entities for erection purposes.

Classification by *area is* limited to:

- large size unit or nil

Phasing by *stage is*:

- joining
- welding or nil.

The welding stage applies only if there are special or extensive welding requirements.

### 3.2.5 *On-block Outfitting*

Outfitting components, units and grand units are sometimes fitted in a block zone defined for hull construction. However, when they are to be fitted to ceilings, blocks should be inverted because fitting down hand enhances safety and efficiency. Therefore, the outfit zone for a block set upside down encompasses everything fitted to the ceiling. Following block turnover, the outfit zone encompasses the components, units and/or grand units fitted to the floor. Turnover represents a change in stage. Specifying a zone per stage for each side suffices for absolute control of on-block outfitting.

Similarly, outfit items should be fitted in the zone of a double-bottom block before its tank top panel is installed. Then at a later stage, a different outfit zone encompasses everything to be fitted to the tanktop. Clearly the primary goals of this manufacturing level are to outfit ceilings and double bottoms when blocks can be manipulated to provide **ideal access.**

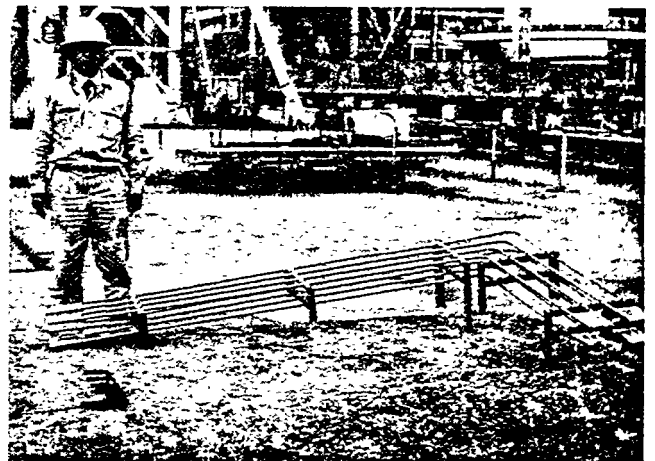
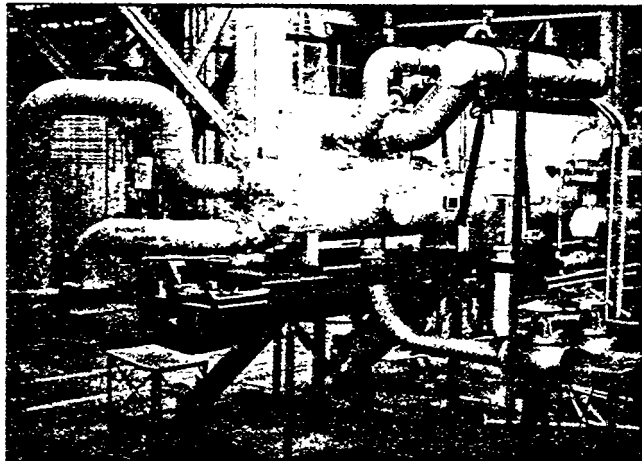
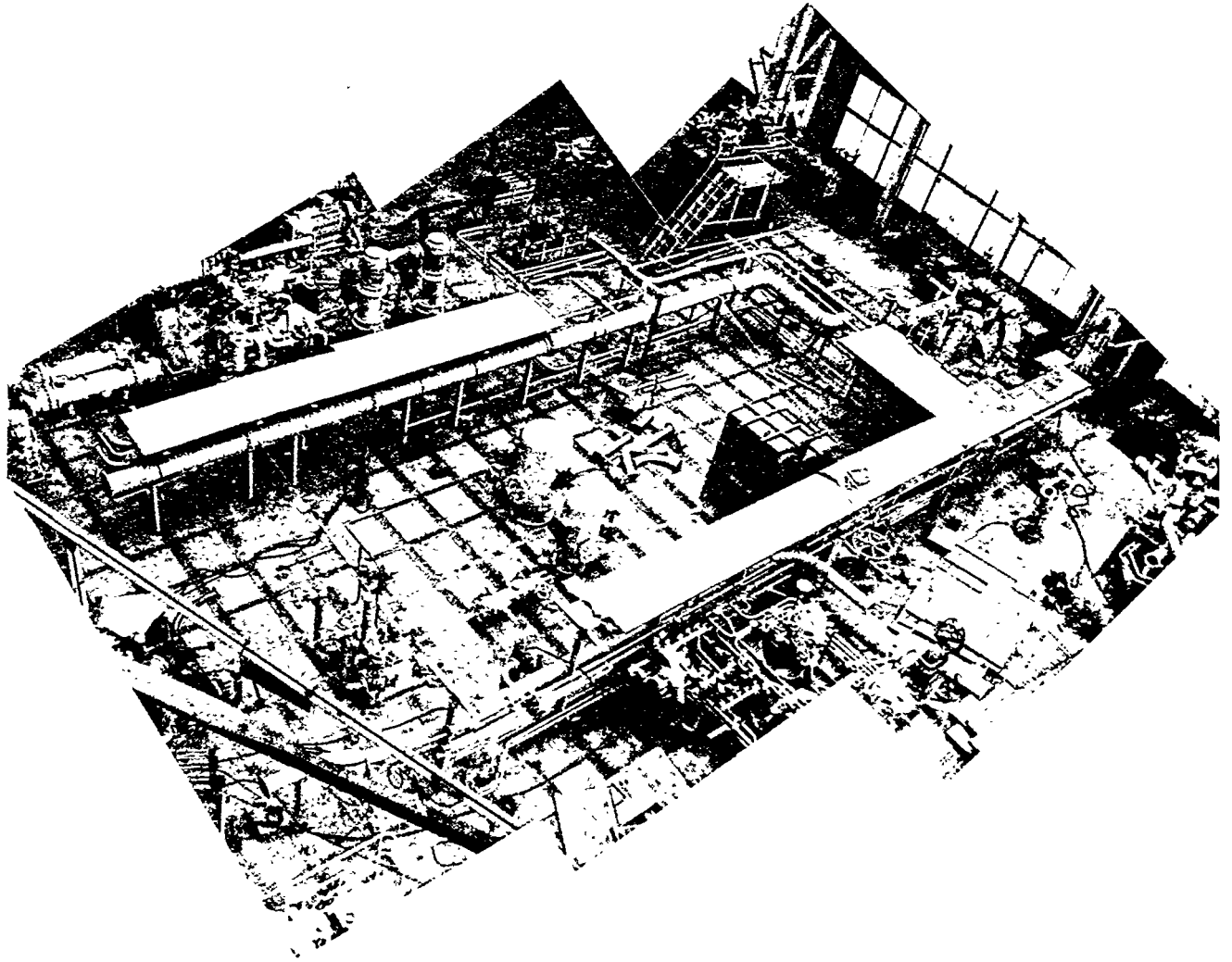
Typically, the divisions by area address problems which are inherently different so that each work package for outfitting on-block can be assigned to the appropriate team of assembly specialists for deck, accommodations, machinery or electrical. These classifications are further subdivided by the quantities of items to be fitted resulting in the following eight problem **area divisions:**

- deck: large quantity or small quantity
- accommodation large quantity or small quantity
- machinery: large quantity or small quantity <sup>6</sup>
- electrical: large quantity or small quantity.

When the items to be fitted comprise a small quantity per block, outfit work can be performed at the site where the block was assembled. When a large quantity is planned, the completed block should be transferred to an indoor or outdoor region designated for outfitting in accordance with an on-flow concept, i.e., where work packages start and complete in unison.

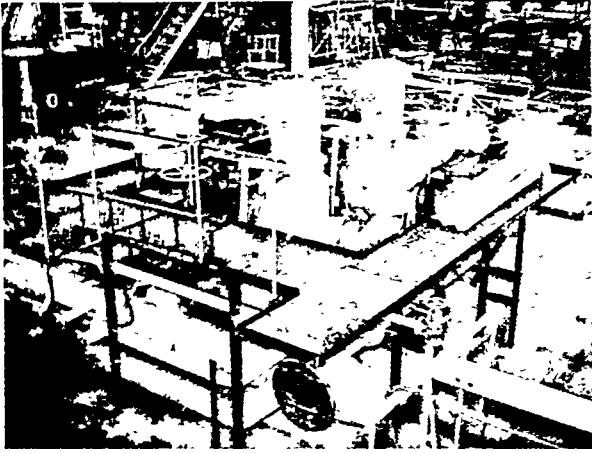
<sup>5</sup> See Design Modules, Patterns and Panels, and Arrangement Zones in "Outfit Planning - December 1979" by C. S. Jonson and L. D. Chirillo for the National Shipbuilding Research Program, pp 26-33.

<sup>6</sup> Pipe assembly problems around machinery are more similar to other machinery space assembly problems than they are to problems for assembling pipe in accommodation spaces. The great effectiveness of organizing people into design groups, fabrication shops or assembly sections, each specialized for deck, accommodation, or machinery, has been proven by the world's most competitive shipbuilders for control of both design and production. Each team within such organizations possesses a mix of pertinent and requisite skills.

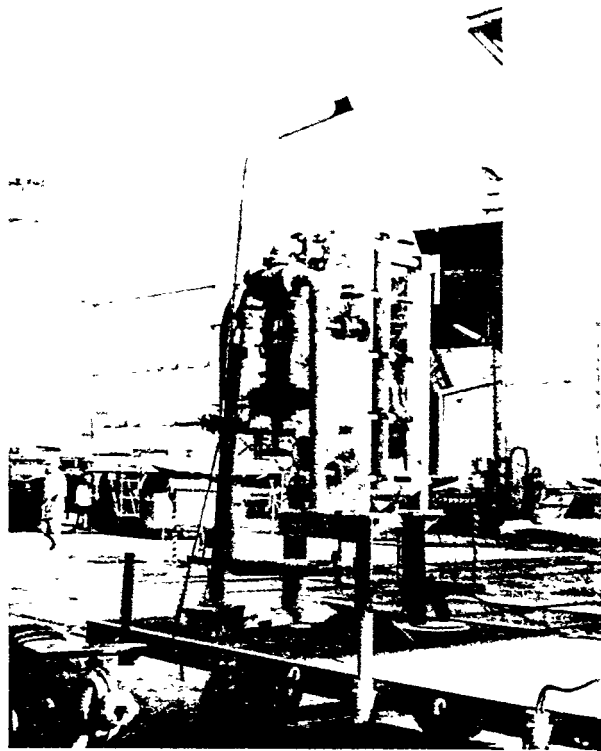


*HF*FIGURE 3-21: Unit sizes vary significantly. *Top*: Engine-room tank-top unit for a 100,000 deadweight-ton diesel-propelled tanker. *Bottom left*: Heat exchanger, foundations, pipe pieces, etc., incorporated as a unit. *Bottom right*: The author showing a small unit consisting of pneumatic tubing and supports.

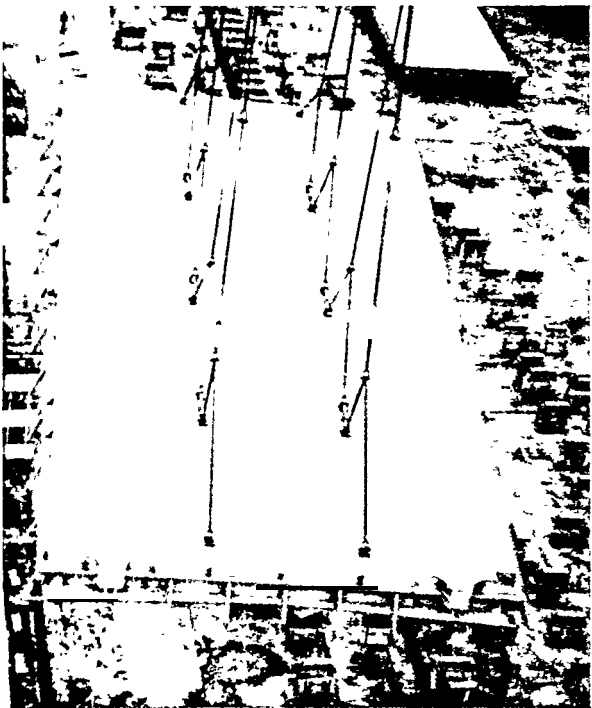




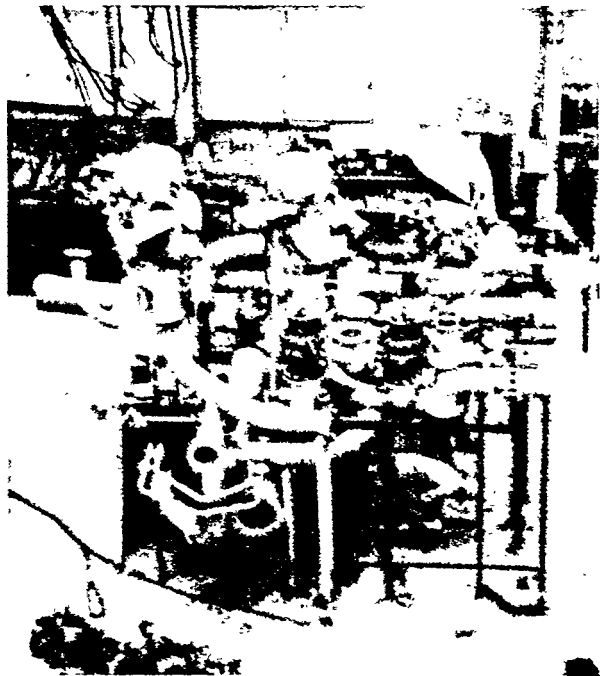
**FIGURE 3-22:** Typical Standard Machinery Unit. Resources include 8 supports, 5 walkway sections plus handrail, 30 pipe-pieces, a smaller unit consisting of 2 interconnected pumps on a common foundation, and a two worker assembly team for one week. Total weight is about 10 tons.



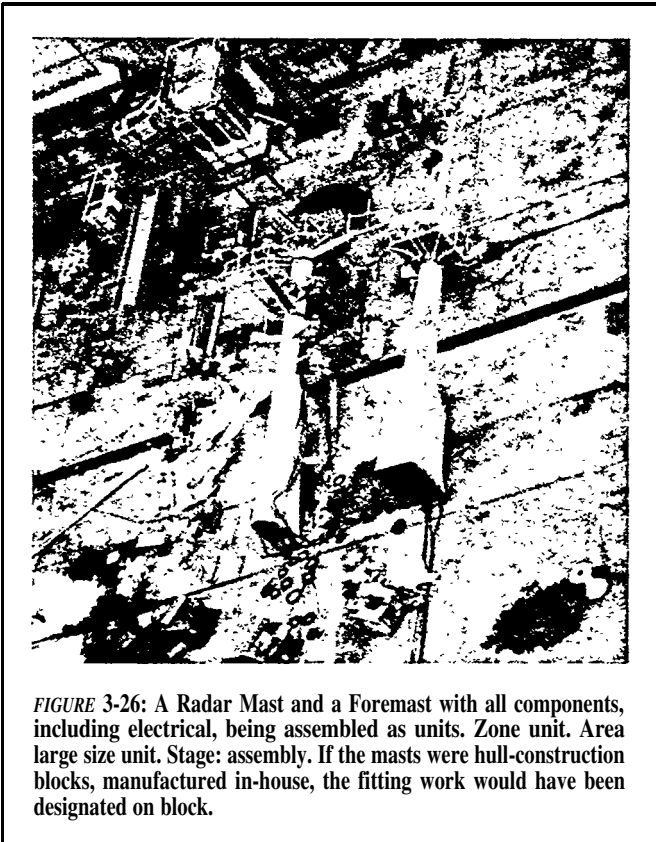
**FIGURE 3-23:** A Lube-oil Cooler, its foundation and surrounding components were assembled on unit.



**FIGURE 3-24:** A Hatch Cover and its Coaming were assembled as a unit. If the coaming was a hull-construction block manufactured in-house, fitting the hatch cover to the coaming would have been planned as on block.



**FIGURE 3-25:** Two General-service pumps, a Peak-Tank Ballast Pump, foundations and surrounding components are assembled as a unit for a 100,000 deadweight-ton tanker. *Zone:* unit. *Area:* large size unit. *Stage:* assembly.



**FIGURE 3-26:** A Radar Mast and a Foremast with all components, including electrical, being assembled as units. Zone unit. Area large size unit. Stage: assembly. If the masts were hull-construction blocks, manufactured in-house, the fitting work would have been designated on block.

Separation by *stage* is in accordance with the following sequence which reflects block turnover:

- on-ceiling fitting
- on-ceiling welding or nil
- on-floor fitting
- on-floor welding or nil.

The welding stages apply only for special or extensive welding requirements. On-ceiling fitting and welding usually is optimum for blocks. However, most on-floor fitting and welding takes place after on-ceiling outfitting is completed, blocks are turned over, and blocks are joined to create grand-blocks. In order to simplify the erection schedule and minimize duration in the building dock, such on-floor outfitting should include all grand units, units and components to the maximum extent possible.

Examples of outfitting on-block are shown in Figures 3-27 and 3-28.

### 3.2.6 On-board Outfitting

Outfitting on-board seems at first to be the same as conventional outfitting. However, the work required is susceptible to the same analyses as for on-unit and on-block outfitting. As a consequence, zone/area/stage control is applicable.

Much outfit work at this level progresses simultaneously with hull erection as shown schematically in Figure 2-4. Ideally, outfitting on-board should be limited to:

fitting components, units and/or grand units that are too large or too heavy to fit on-block (e.g., main engines, diesel generators, most units and grand units for engine room tank top, etc.),

fitting fragile and weather-vulnerable components that could be damaged if installed before compartments are enclosed (e.g., joinery, insulation, electronic equipment, etc.), and

connecting between components, units and grand units that are either fitted-on-block or on-board.

One useful method of classifying work packages by problem *area* simultaneously addresses the teams of specialists needed, work volume sizes, and skill requirements in accordance with the following twelve categories:

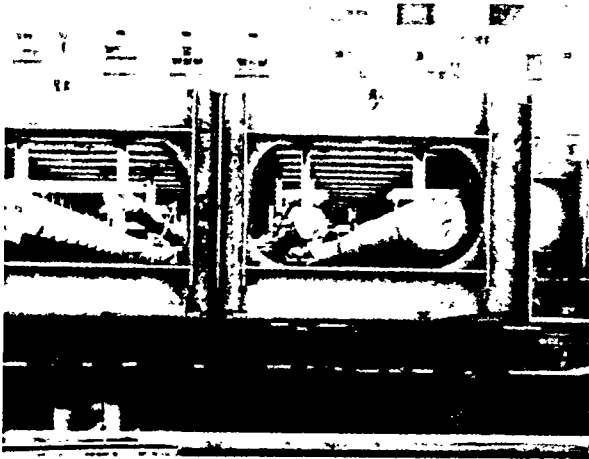
- deck: similar work in small volume, high volume, or high skill
- accommodation: similar work in small volume, high volume, or high skill
- machinery similar work in small volume, high volume, or high skill
- electrical similar work in small volume, high volume, or high skill.

Variety work in small volume should be encompassed in an on-board zone for execution by a team having the needed variety of skills. Variety work in large volume should be divided by similarities in components and units or sets of components and/or units. Zones for such problem areas should not be too long, wide, scattered or otherwise unfavorable for execution and supervision of work. At the same time planners must regard the need for high-skill fitting work required in many ship compartments. In such cases, large zones grouped by specific problem areas could be most beneficial.

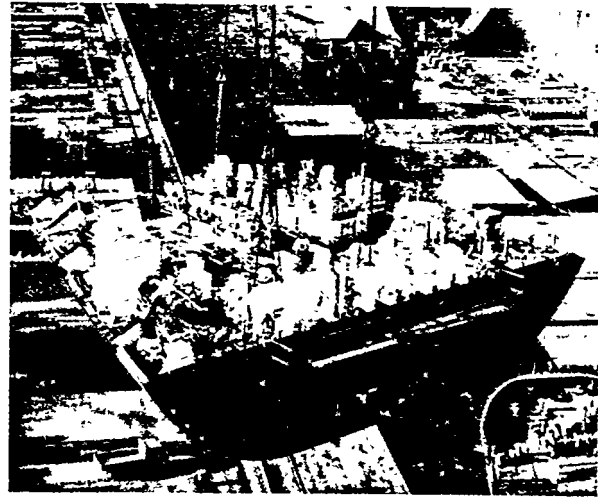
*Stage* for on-board outfitting could be divided into:

- open-space (blue sky) fitting
- open-space (blue sky) welding or nil
- closed-space fitting
- closed-space welding or nil.

The welding stages apply only if there is special or extensive welding to be done. Open-space fitting and welding should be completed before closures imposed by the continuing erection of blocks in order to take full advantage of ideal access. Therefore, such work should be incorporated in the erection schedule. Closed-space fitting and welding activities should be minimized as much as practicable as they require



**FIGURE 3-27:** On-block Outfitting in Pipe Tunnel Below Cargo Hold.



**FIGURE 3-28:** Engine-room Tank-top Components Fitted On-Block. Sometimes, as in this example, where there is sufficient lift capacity and reserved time, fitting on-block is just as efficient as fitting on-unit.

more working hours, more transportation services, longer durations, etc.

The on-board outfitting level uses on-board divisions as zones which are subdivisions of the ship as a zone as for the erection level in hull construction work.

### 3.2.7 Operation and Test

The operation and test level applies to work necessary for assessing the performance of each ship's functional systems. At this level *zone* is the entire ship.

Problems are grouped to match teams of specialists for the following *areas*:

- deck
- accommodation
- machinery
- electrical.

Further, operation and test is regarded as a single *stage*. Thus, at this level, work is packaged by one or more systems within each of the problem areas defined for the specialist teams. It is the traditional method for planning operation and test work.



### 3.3 Zone Painting Method

The Zone Painting Method (ZPTM) is a natural extension of the logic employed in both HBCM and ZOFM. It transfers much painting work, traditionally performed in a building dock or at an outfit pier, to preceding manufacturing levels by integrating painting with hull construction and outfitting processes. Painting is treated as another assembly process that ascends through manufacturing levels as typically shown in Figure 3-29. There are certain prerequisites for successful application:

- the painting interval between one coat and a next coat must be shorter than the allowable exposure period for the former,
- each hull block should be virtually finished in order to minimize surface preparation and painting rework caused by further cutting, fitting and welding, and
- the shop primers applied to plates and shapes should **not impede efficient cutting and welding.**

The main planning objectives for shifting paint related work to the manufacturing levels prior to on-board painting are to:

- shift positions from overhead to down hand or at the minimum to vertical, from high to low places, and from confined to readily accessible places,
- facilitate the use of temperature and humidity controlled buildings, especially for sophisticated coatings,
- provide safer environments without extraordinary devices that would encumber workers,
- prevent in-process rust and associated rework,
- minimize scaffolds needed only for surface preparation and painting, and
- level load work throughout the entire shipbuilding process in order to avoid large work volumes in the final stages that could jeopardize scheduled delivery.

Typical grouping of paint related work packages by their product aspects are contained in Figure 3-30. Horizontal combinations characterize the various types of work packages that are requisite and sufficient for the work to be performed for each level. Vertical combinations denote the process lanes for painting work flow. Obviously, there is need for balanced planning and scheduling and cooperation between hull construction, outfitting and painting planners. Examples of paint systems applied in accordance with ZPTM are contained in Figure 3-31.

#### 3.3.1 Shop Primer Painting

This manufacturing level applies to surface preparation for and application of shop primer to raw materials before they are processed to create structural parts or outfit components. Items which are to be pickled after their manufac-

ture are usually excluded. Thus, useful divisions by problem *area* are:

- plate
- shapes and other.

The applicable *stage* categories are:

- shot blasting
- painting.

#### 3.3.2 Primer Painting

This level is for application of an anti-corrosive, including epoxy and inorganic zinc-silicate, which is the first coat applied to a component or an on-board division (as defined in ZOFM), or a block (as defined in HBCM). These constitute the *zone* categories.

Problem *area* is grouped by:

- paint type, i.e., conventional, epoxy, inorganic zinc-silicate, etc.
- number of coats
- type of *zone*.

The latter further classifies each component, block or on-board division, by problem *area* to anticipate:

- burn or wear damage of painted surfaces during HBCM and ZOFM succeeding manufacturing levels,
- difficulty if there is a change in painting conditions, e.g., down hand to overhead, low to high, spacious to confined, etc., and
- need to maintain appearance.

These considerations again demonstrate that ZPTM, ZOFM and HBCM planning must be coordinated. Painting planners have to consider the foregoing for each zone at all ZOFM and HBCM manufacturing levels.

*Stage* at this level is separated into the following phases:

- surface preparation
- cleaning
- touch UP
- painting
- surface preparation after block turnover or nil
- cleaning after block turnover or nil
- touch up after block turnover or nil
- painting after block turnover or nil.

---

<sup>7</sup>In order to fulfill these prerequisites hull construction, outfitting and painting planners have to work together to shorten the durations between the shop primer and primer levels and between the primer and finish under-coat levels. And, managers have to ensure effective accuracy control.

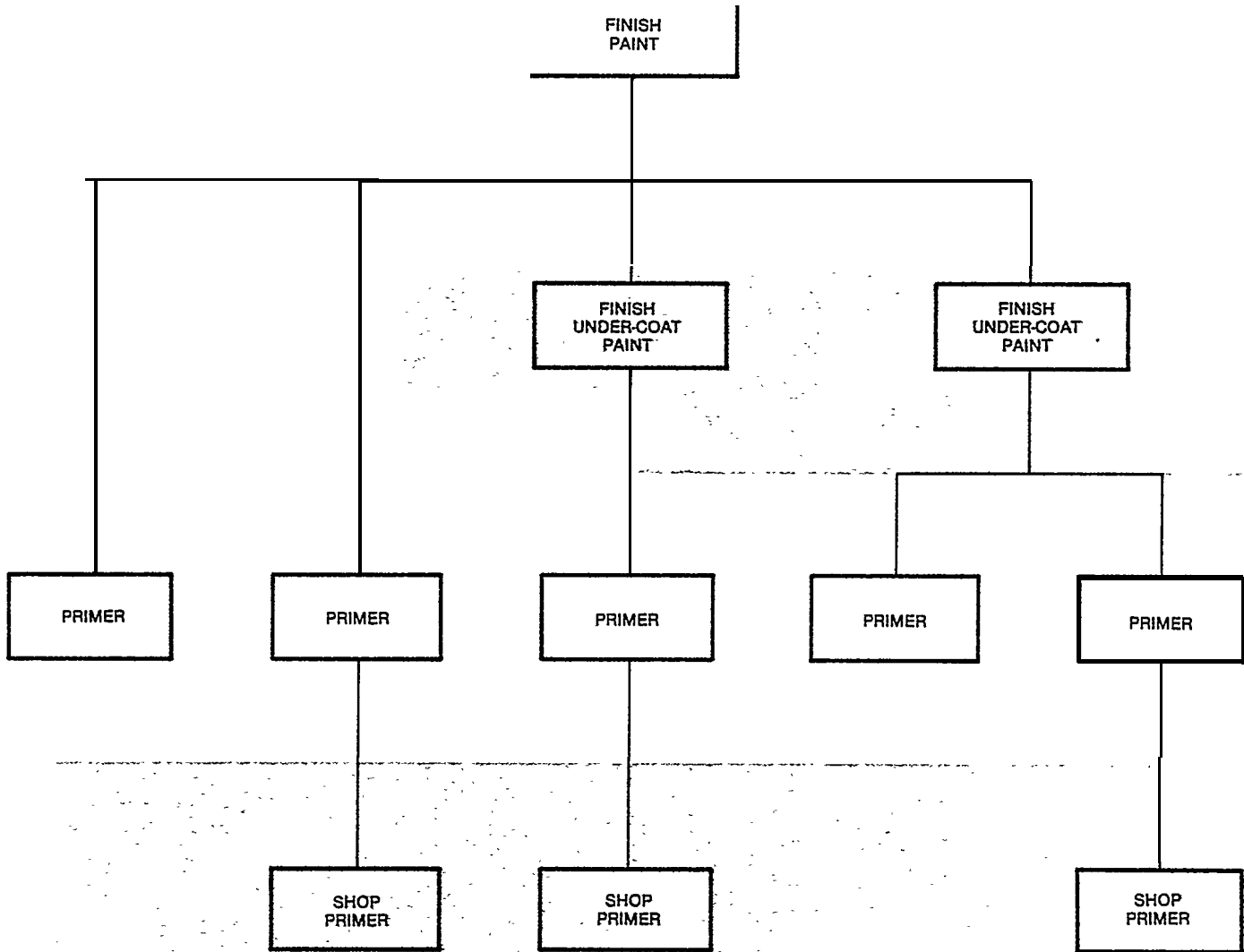


FIGURE 3-29: Typical Manufacturing Levels for the Zone Painting Method (ZPTM).

PLAN'G LEVEL	M'FG LEVEL
1	4
2	3
3	2
4	1

CTS			
		EA	
COMPONENT	UNIT TO BE FITTED AT ON-BLOCK OUTFITTING	PAINT MATERIAL NUMBER OF COATS/ TYPE OF ZONE/ PAINT SCAFFOLD REQUIRED OR NOT	PAINING
	COMPONENT FITTED ON-BLOCK AT ON-BLOCK OUTFITTING		NIL
BLOCK	NIL	PAINT MATERIAL NUMBER OF COATS/ TYPE OF ZONE/ PAINT SCAFFOLD REQUIRED OR NOT	TOUCH UP
			CLEANING
MATERIAL	NIL	PAINT MATERIAL NUMBER OF COATS/ TYPE OF ZONE	SURFACE PREPARATION
			PAINTING
PLATE	SHAPES AND OTHER	PAINT MATERIAL NUMBER OF COATS/ TYPE OF ZONE	PAINTING AFTER OVERTURNING
			TOUCH UP AFTER OVERTURNING
SHAPES AND OTHER	NIL	PAINT MATERIAL NUMBER OF COATS/ TYPE OF ZONE	CLEANING AFTER OVERTURNING
			SURFACE PREPARATION AFTER OVERTURNING
SHAPES AND OTHER	NIL	PAINT MATERIAL NUMBER OF COATS/ TYPE OF ZONE	PAINTING
			TOUCH UP
SHAPES AND OTHER	NIL	PAINT MATERIAL NUMBER OF COATS/ TYPE OF ZONE	CLEANING
			SURFACE PREPARATION
SHAPES AND OTHER	NIL	PAINT MATERIAL NUMBER OF COATS/ TYPE OF ZONE	PAINTING
			CLEANING
SHAPES AND OTHER	NIL	PAINT MATERIAL NUMBER OF COATS/ TYPE OF ZONE	SURFACE PREPARATION
			PAINTING
SHAPES AND OTHER	NIL	PAINT MATERIAL NUMBER OF COATS/ TYPE OF ZONE	CLEANING
			SURFACE PREPARATION
SHAPES AND OTHER	NIL	PAINT MATERIAL NUMBER OF COATS/ TYPE OF ZONE	PAINTING
			SHOT-BLASTING

DES		
ZONE	EA	STAGE
FINISH PAINT SIGN/ ZONE CODE	FINISH UNDER-COAT PAINT SIGN/ ZONE CODE	FINISH PAINT SIGN/ ZONE CODE
PRIMER SIGN/ ZONE CODE	PRIMER SIGN/ ZONE CODE	PAINT CODE/ NUMBER OF COATS
SHOP PRIMER SIGN/ ZONE CODE	MATERIAL CODE	PAINT CODE/ NUMBER OF COATS
STAGE CODE OF HBCM, ZOFM, OR PPFM		

FIGURE 3-30: Typical classifications of product aspects for the Zone Painting Method (ZPTM).

MANUFACTURING LEVEL	PAINT SYSTEM A	PAINT SYSTEM B
FINISH	COLOR	COLOR
FINISH UNDER-COAT	COLOR	COLORED PRIMER
PRIMER	PRIMER NUMBER OF COATS PER SPECIFICATION	PRIMER
SHOP PRIMER	SHOP PRIMER	SHOP PRIMER

FIGURE 3-31: Examples of paint systems applied in accordance with the Zone Painting Method (ZPTM). Finish under-coat and finish are not applied everywhere, i.e., they are applied only where specified.

The work at this manufacturing level is coordinated with ZOFM so that primer is applied just before the on-ceiling fitting stage and, following block turnover, just before the on-floor fitting stage. “Nil” applies to blocks that are not turned over.

### 3.3.3 Finish Under-coat Painting

This is the semi-final manufacturing level for paint application. Useful zone classifications are

- components (big in size or which become relatively inaccessible after fitting on-board such as masts, cargo booms, undersides of hatch covers, etc.)
- units which are to be fitted on-board
- outfitted blocks
- on-board divisions
- nil (applicable if epoxy is specified).

Problem area divisions are:

- paint type
- number of coats
- type of zone (as described in Part 3.3.2 for the primer painting level)
- scaffolding required only for painting or not.

The classification of work packages by stage is the same as for the primer level.

### 3.3.4 Finish Painting

Finish painting is the final manufacturing level in ZPTM. Zone, area and stage classifications are the same as in the final under-coat level except that:

- stages associated with block turnover are not applicable, and
- “nil” in the final stage “painting or nil” means a finish coat will not be applied, as in the case of epoxy.



### 3.4 integrated Hull Construction, Outfitting & Painting

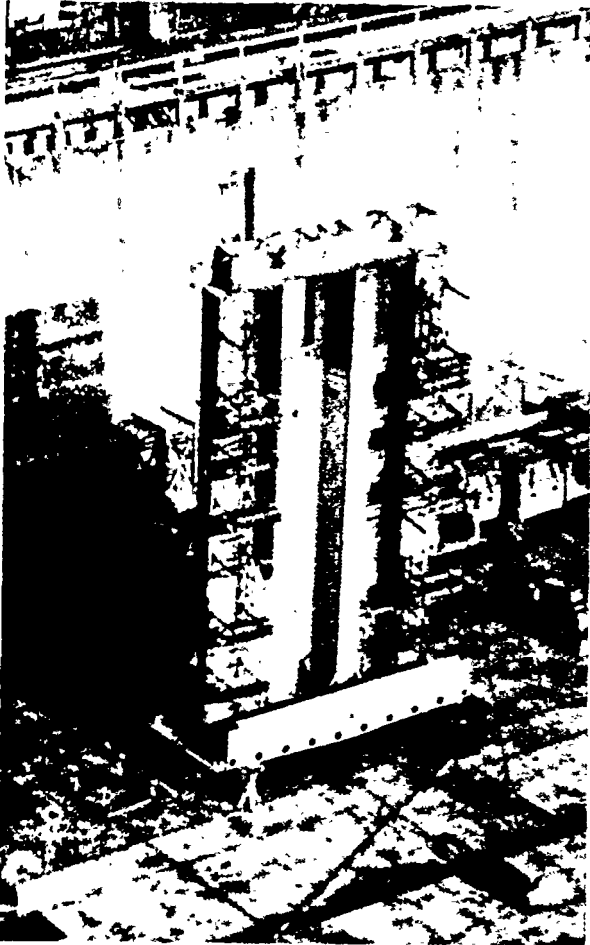
The zone-oriented methods described in Parts 3.1, 3.2 and 3.3, i.e., the:

- Hull Block Construction Method (HBCM),
- Zone Outfitting Method (ZOFM), and
- Zone Painting Method (ZPTM),

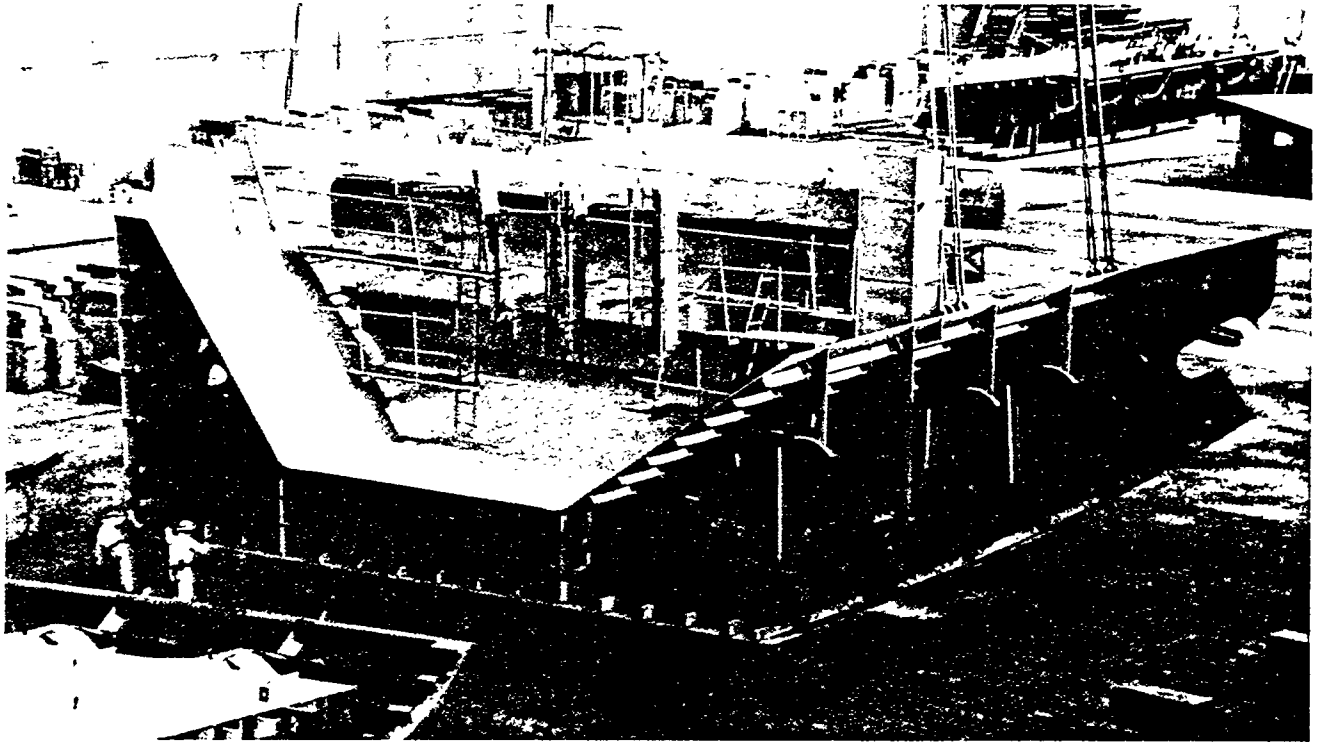
were developed from the same logic. But just understanding the logic and learning application principles are not enough.

*There is need for managers, deputy managers and field engineers in assembly organizations who are college trained or who have otherwise obtained ability to think analytically about industrial engineering matters. There is also need for extraordinary leadership to counter the tendency of people to favor one type of work at the expense of others.*

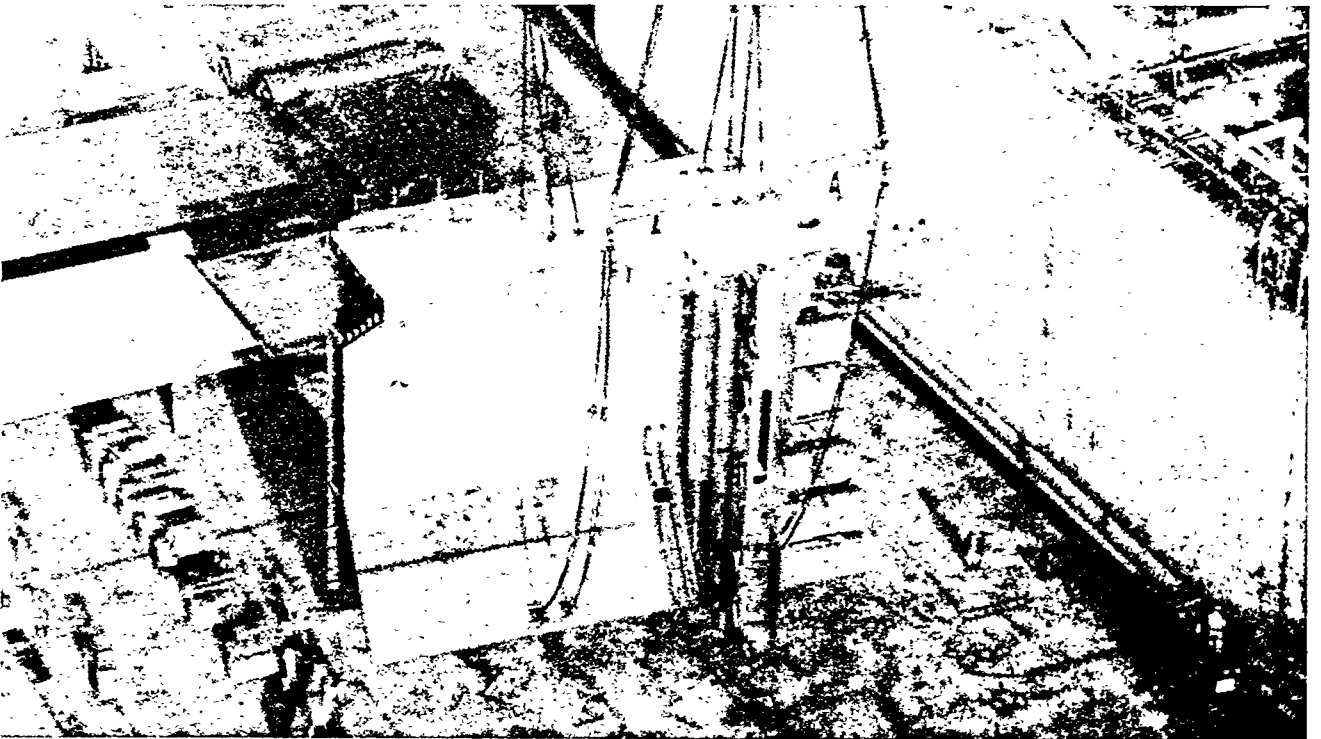
Integrated HBCM, ZOFM, and ZPTM for a 22,000 deadweight-ton multi-purpose cargo carrier, which is not one of a standard series, is illustrated in Figures 3-32 through 3-56. Typically, all work shown was performed during a single 8-hour shift per workday. Sometimes nominal overtime is applied, usually for painting.



**FIGURE 3-32:** Grand Block, upside down, of Center Deck and Center Transverse Bulkhead (similar to grand block in Figure 3-10). Temporary staging is fitted to facilitate erection welding. Most of the primer coat was applied on block before grand-block joining. After erection the bottom third will be readily accessible for application of the remaining primer coat.



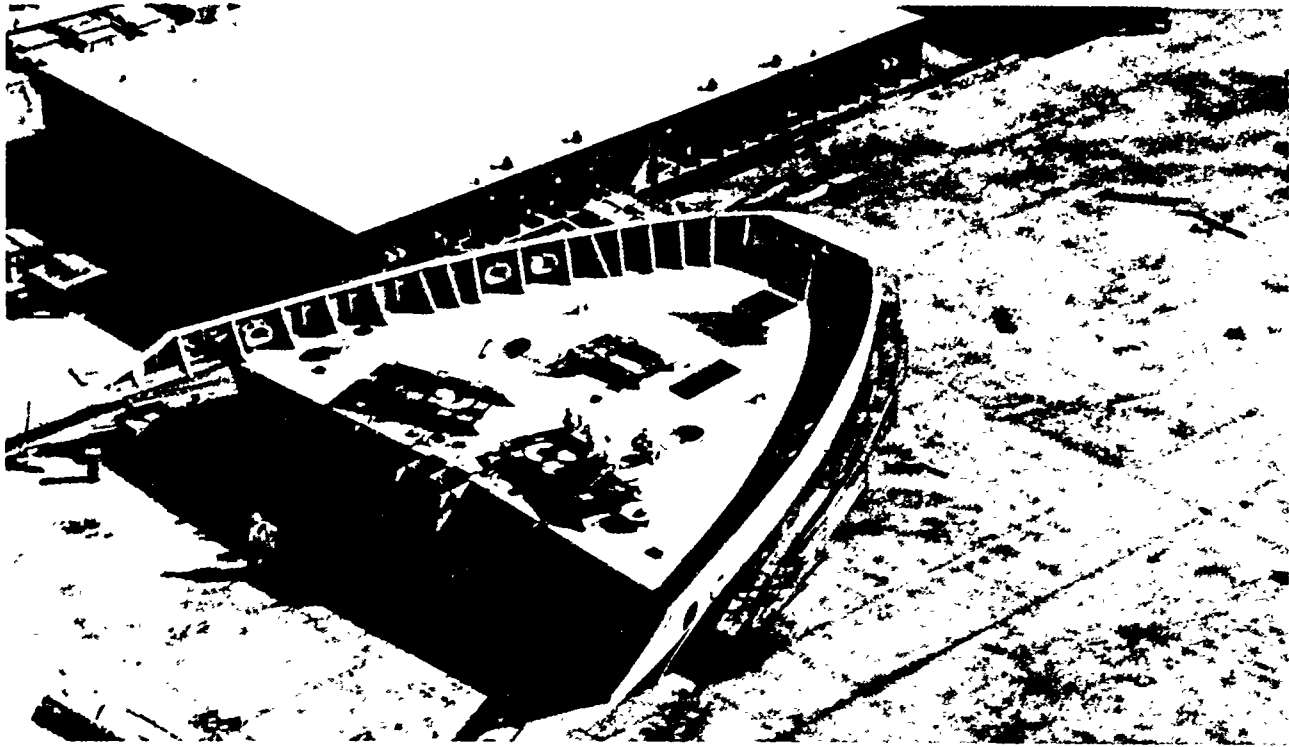
**FIGURE 3-33:** Grand Block of Side Shell, Top Side Tank, Transverse Hopper, and Side Transverse Bulkhead of Cargo Hold. Temporary staging is in place to facilitate erection welding. Primer has been applied to all surfaces except the bottom third which will be readily accessible after erection.



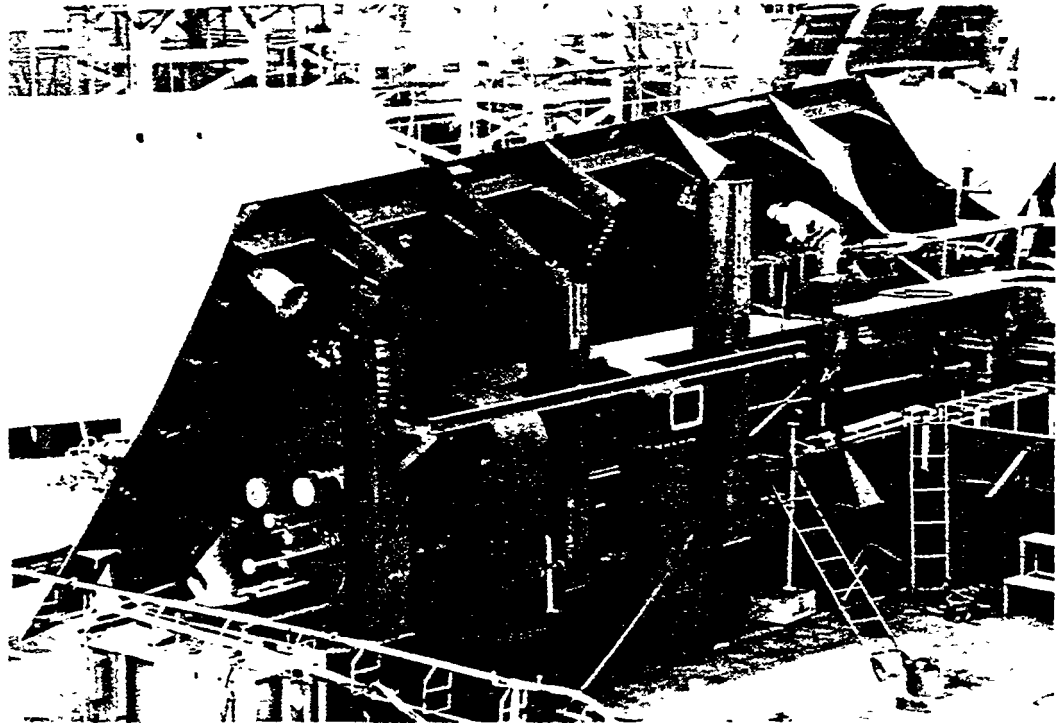
**FIGURE 3-34:** Same Grand Block as shown in Figure 3-33. The exposed shop primer, limited to the Transverse Hopper surface in this view, is in good condition.



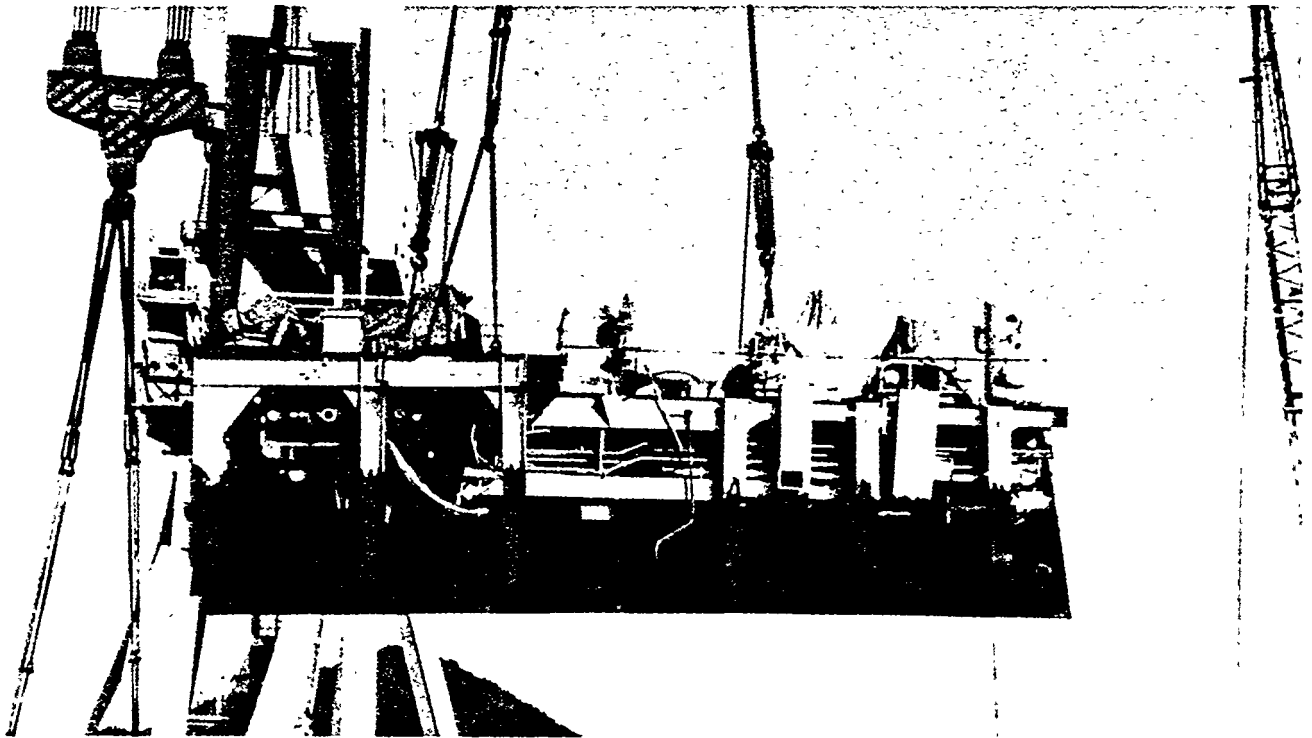
*FIGURE 3-35: On-block Outfitting Level. Zone: volume encompassed by the shell and transverse bulkhead. Area: deck components in a small quantity (work progresses off flow). Stage: on-ceiling fitting. Red primer was applied just before fitters started. A small portable crane suffices.*



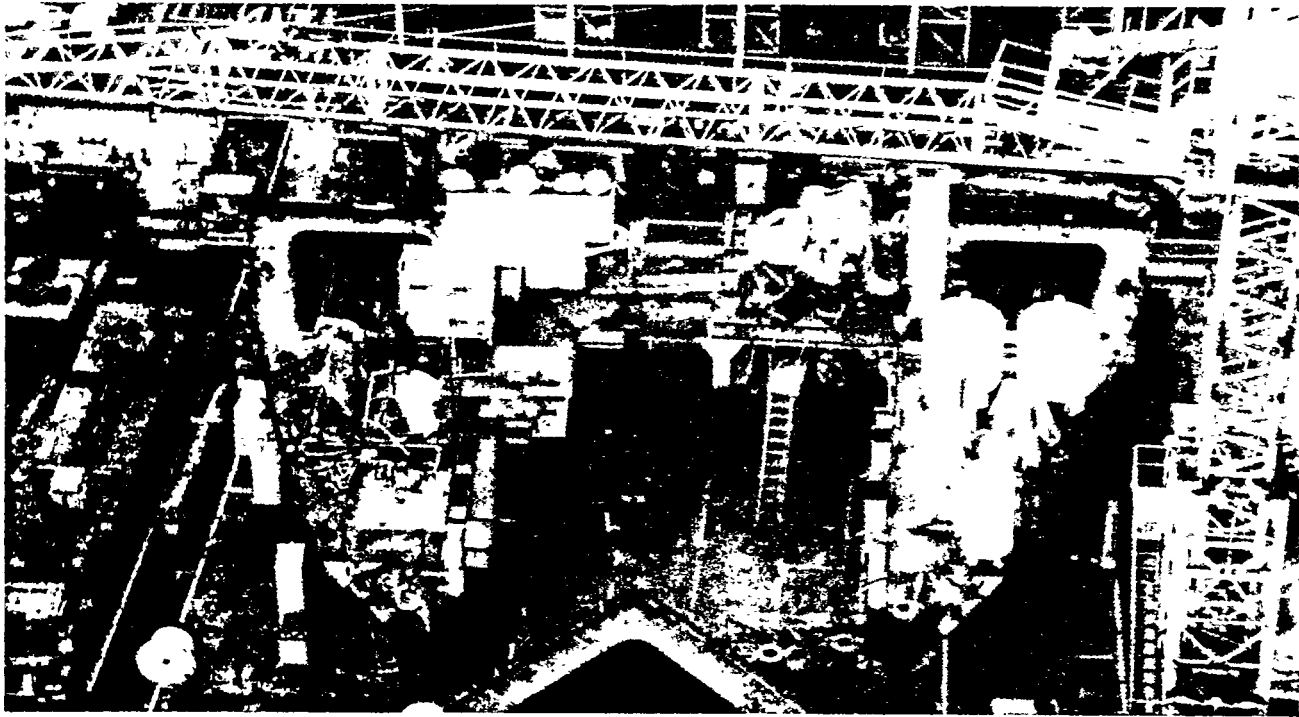
*FIGURE 3-36: On-block Outfitting Level. Zone: accessible exterior surfaces. Area: deck components in a small quantity. Stage: on-floor fitting. A primer has already been applied over shop primer except in localities where welding work remains.*



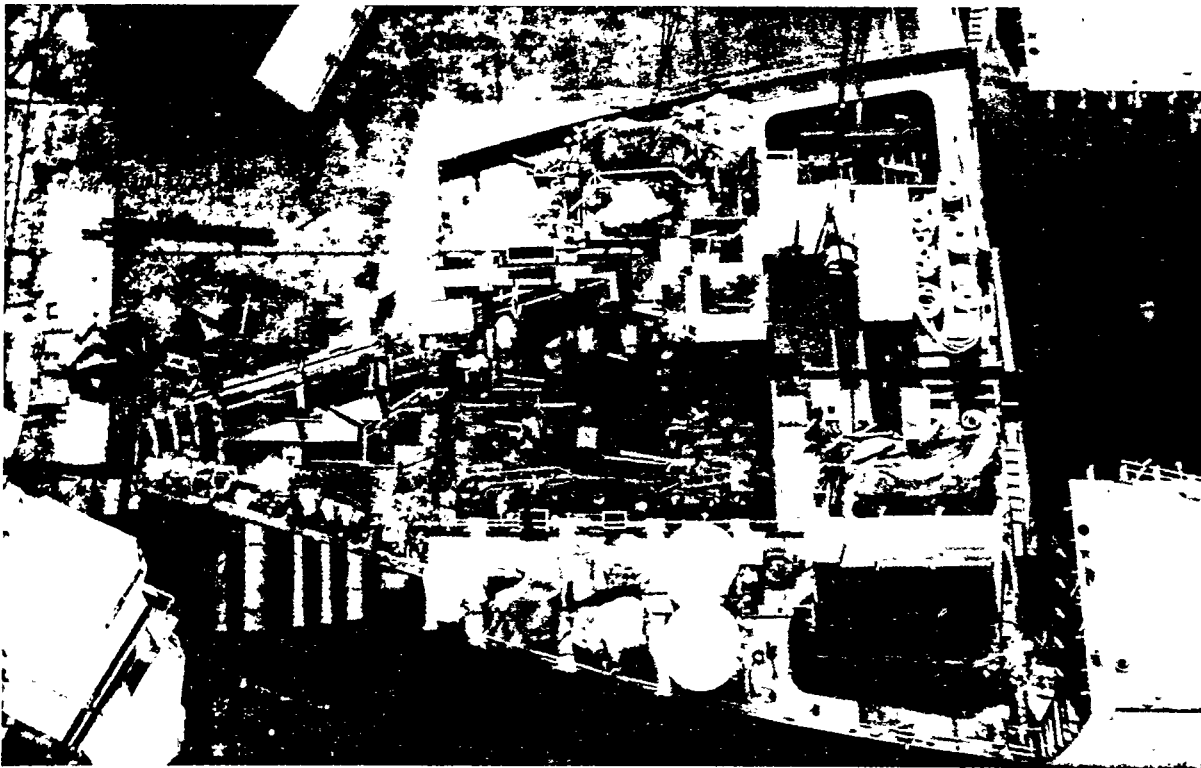
*FIGURE 3-37: On-block Outfitting Level. Zone: region encompassed by side shell, engine-room flat and columns. Area: machinery components in large quantity (on flow). Stage: on-ceiling fitting. Before fitters started, red primer was applied to readily accessible structure. A primer coat was applied to individual pipe pieces, vent-duct pieces, etc., by their in-house or outside manufacturers.*



*FIGURE 3-38: Same block as in Figure 3-37 after on-floor fitting and finish under-coat painting (white). The incomplete primer coat, shown in Figure 37, was completed just after on-floor fitting when the lower structure was readily accessible.*



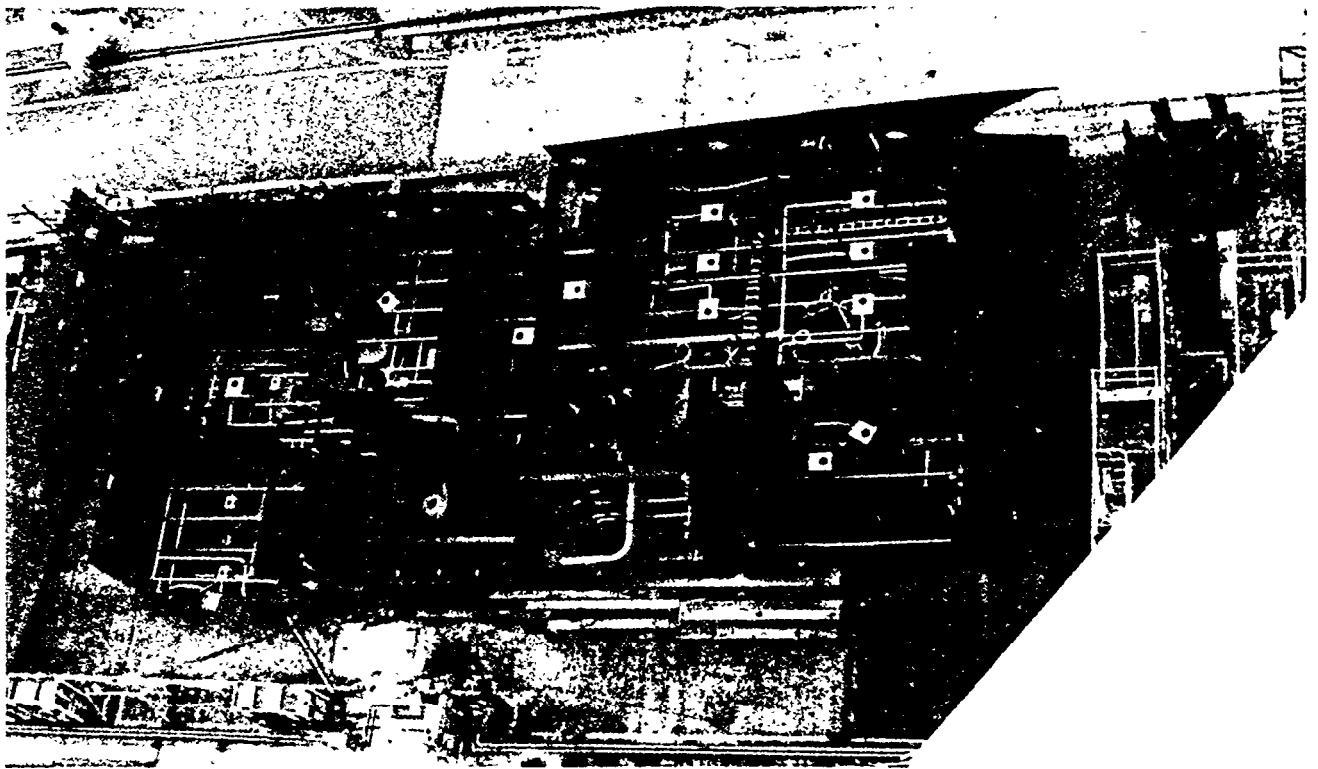
**FIGURE 3-39:** On-block Outfitting Level. The right-side block is the same one shown in Figures 3-37 and 3-38. Zone and area are as described in Figure 3-37. Stage: on-floor fitting. This on-floor work is progressing next to the building dock. A light crane, of the type used for constructing buildings, is sufficient.



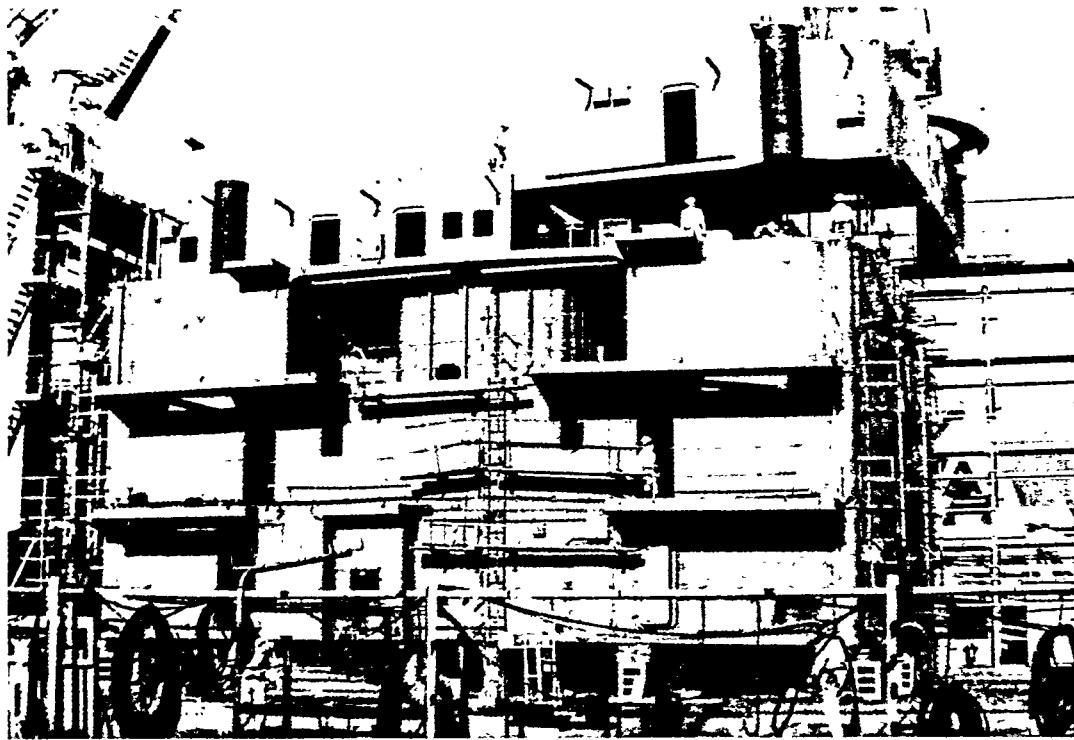
**FIGURE 3-40:** Erecting the outfitted blocks shown in Figures 3-37,3-38 and 3-39. These comprise the 1st Engine-room Flat.



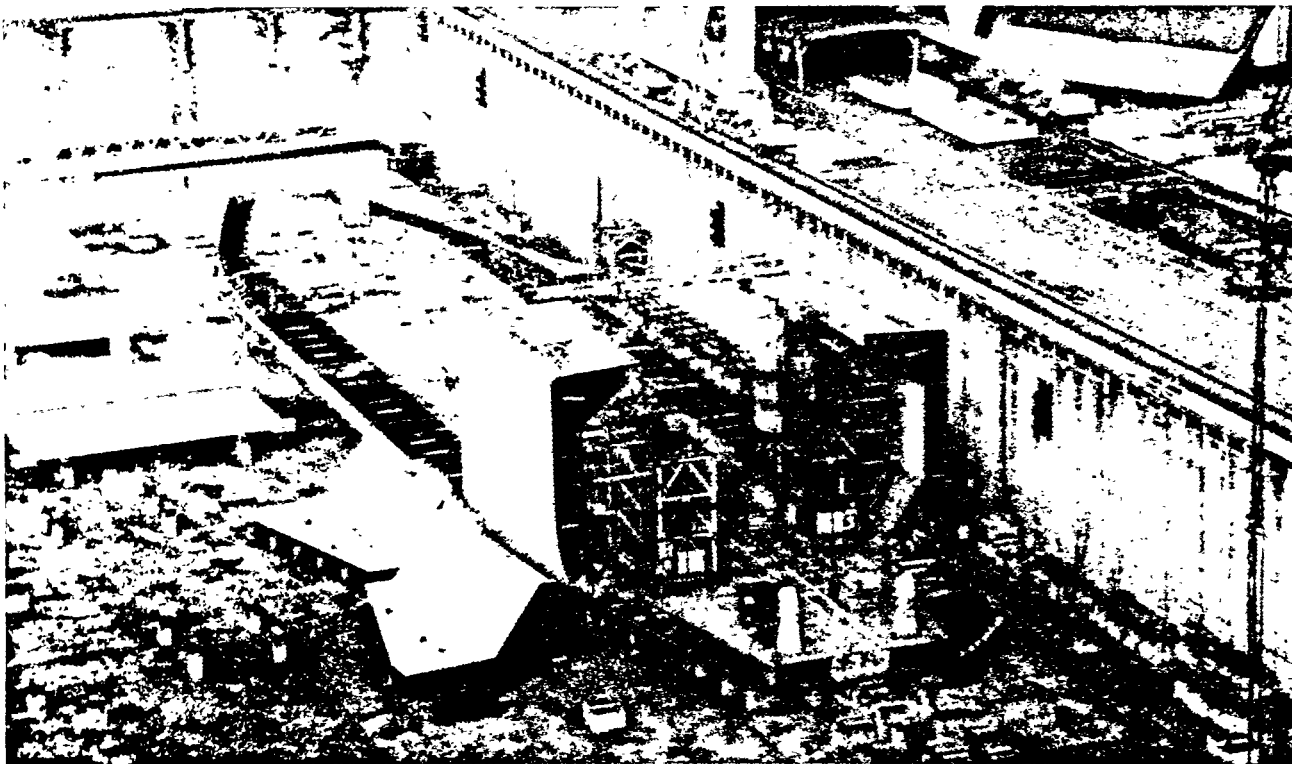
*FIGURE 3-41:* On-block Outfitting Level. Zone: half of a superstructure deck. Area: accommodation components in large quantity (on flow). Stage: on-ceiling fitting. Red primer was applied just before outfitting started.



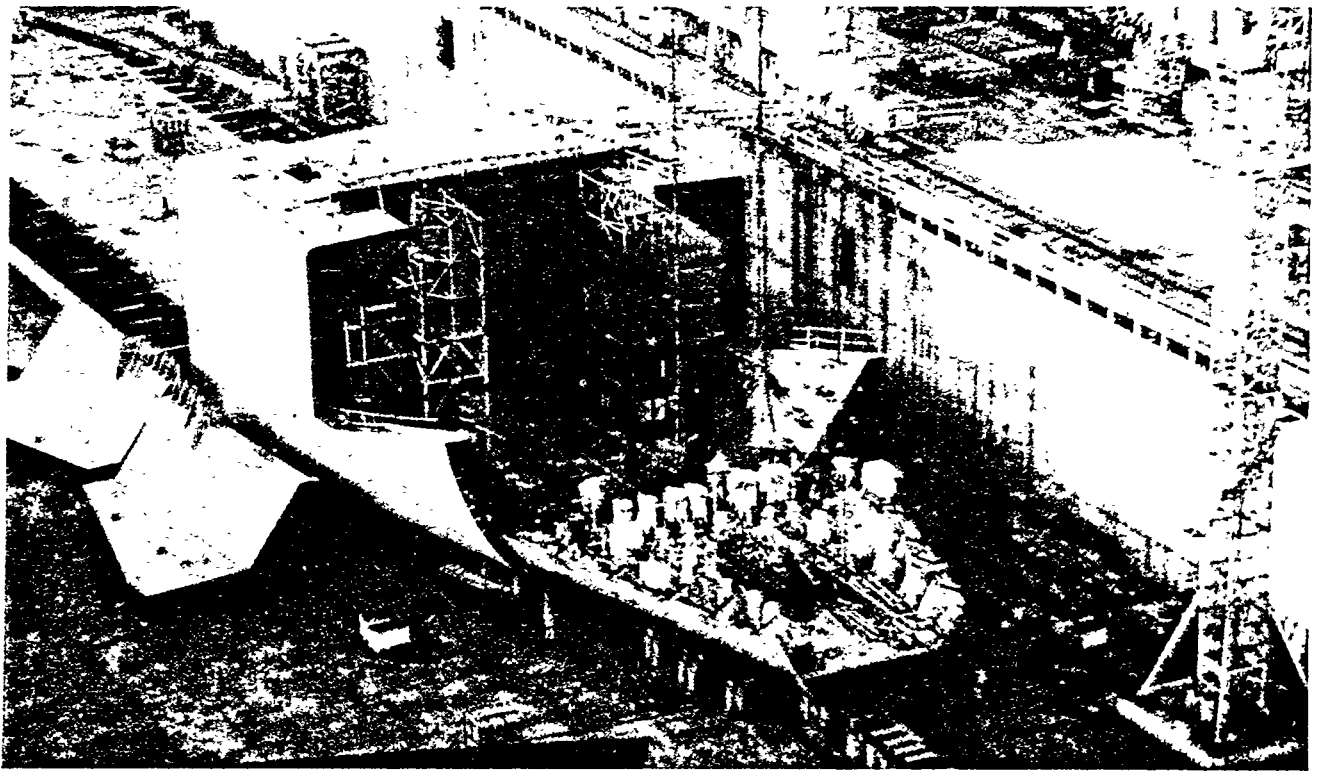
*FIGURE 3-42:* On-block Outfitting Level. Zone, *area* and *stage* are the same as in Figure 3-41. The block is different.



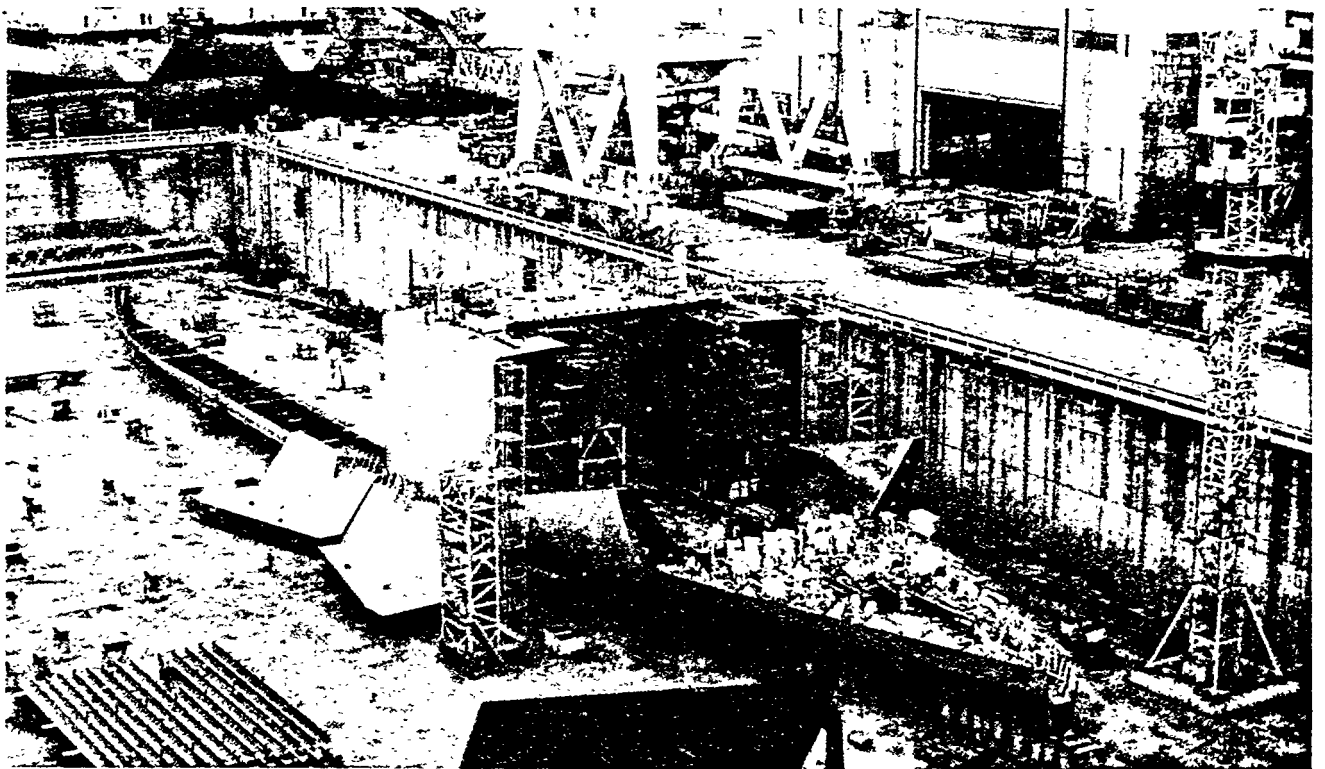
*FIGURE 3-43: Grand-block Joining Level. Zone: aft half of superstructure. Area: superstructure. Stage: pre-erection (this designates grand grand-block joining).*



*FIGURE 3-44: Erection Level. Keel laying plus 11 workdays.*



*FIGURE 3-45:* Erection Level. Landing the block shown in Figure 3-28. Keel laying plus 13 workdays.



*FIGURE 3-46:* Erection Level. Engine-room tank-top blocks are erected. Keel laying plus 15 workdays.



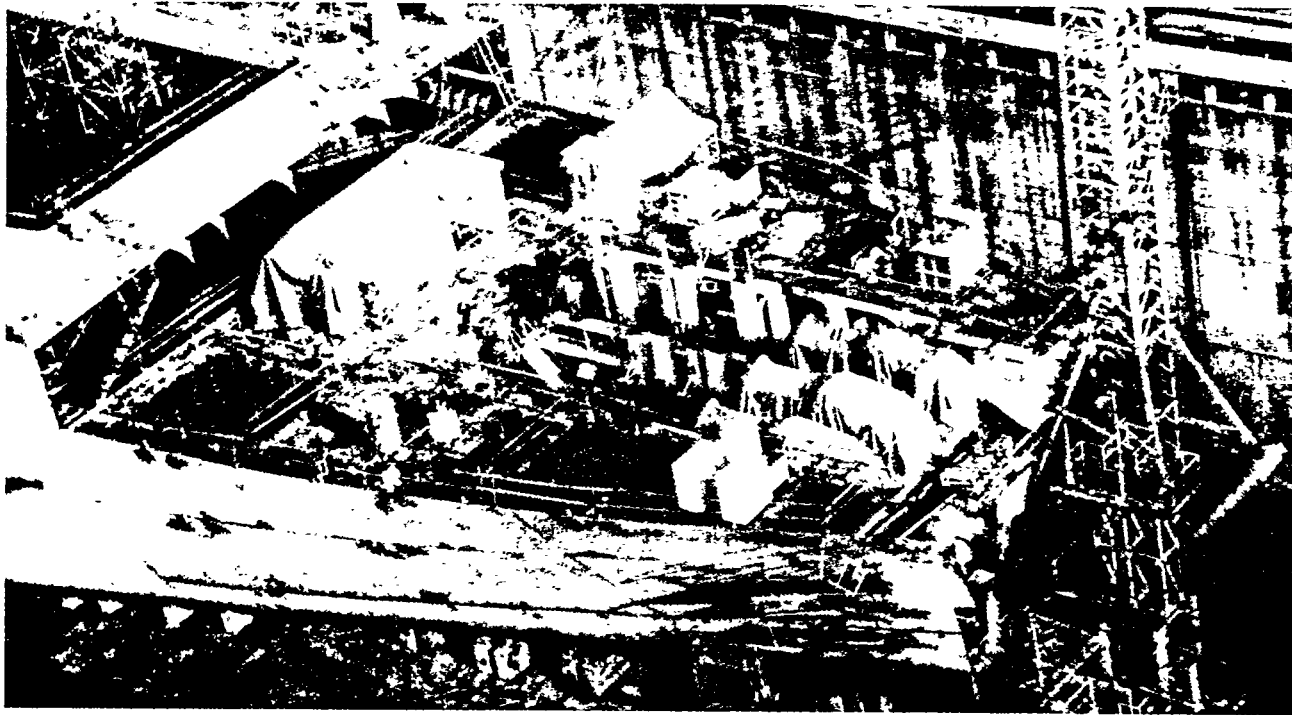


FIGURE 3-47: Erection Level. Blocks similar to those shown in Figures 3-37 through 3-40 comprise much of the 2nd Engine-room Flat. The covered control console forward and three covered diesel-generators aft, were landed during an on-open-space fitting stage (blue sky fitting). Keel laying plus 19 workdays.

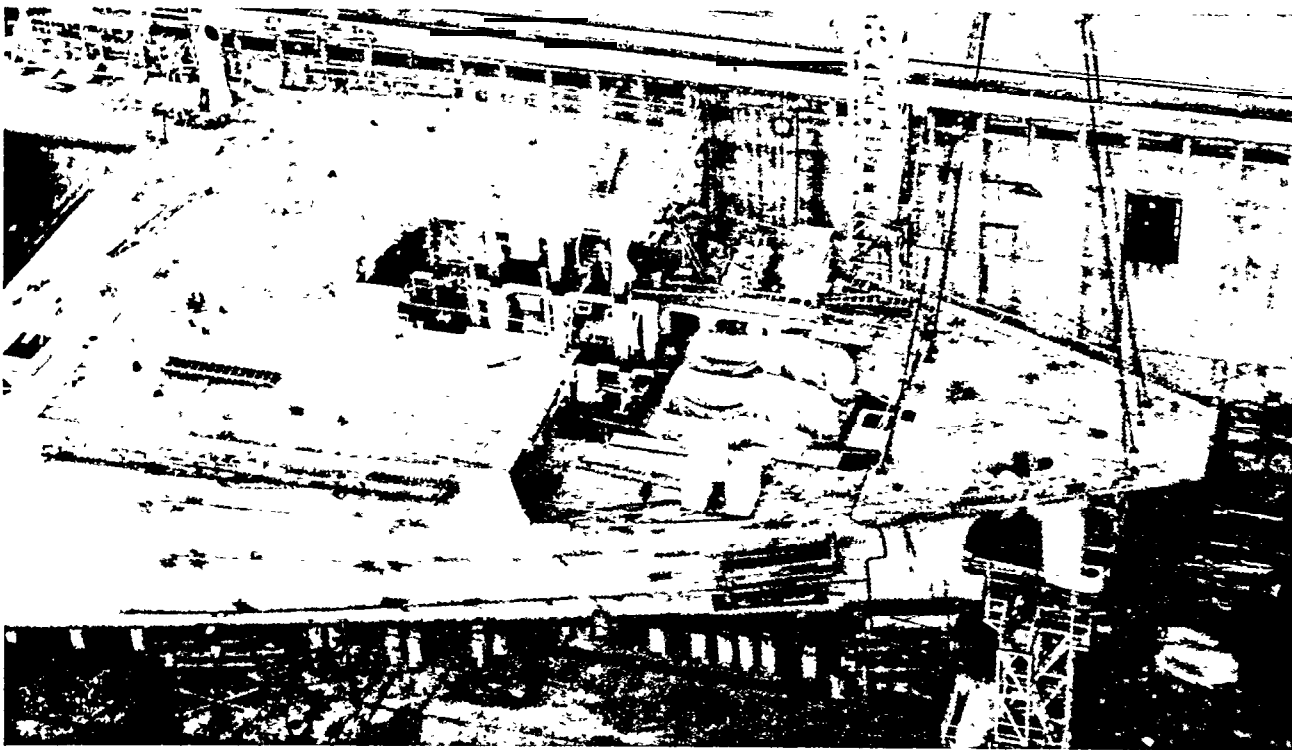
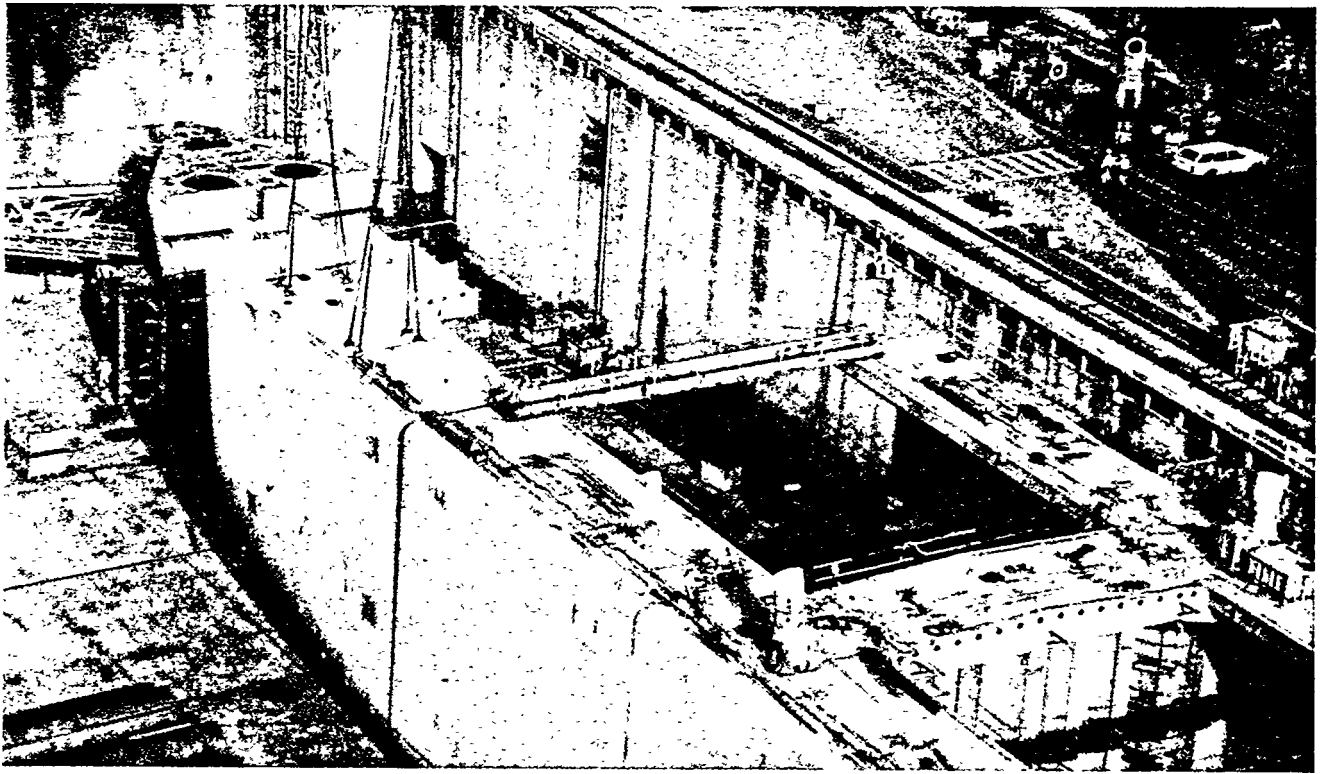
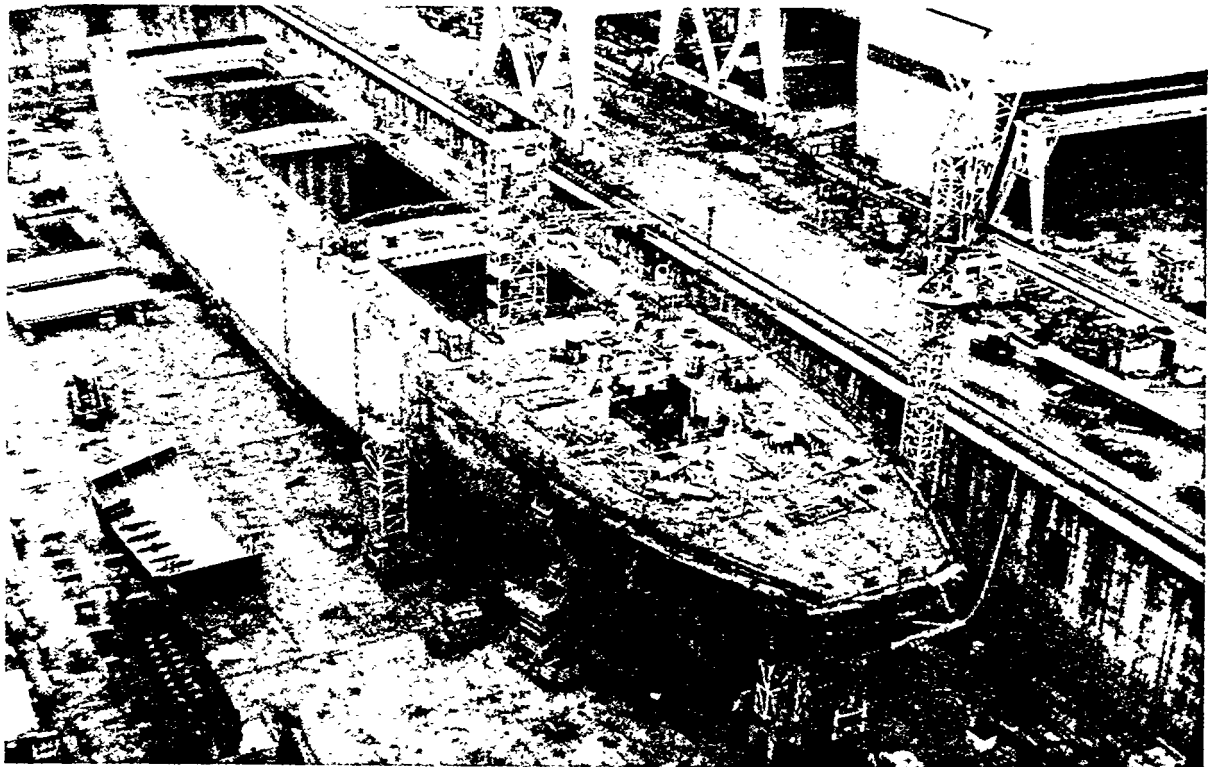


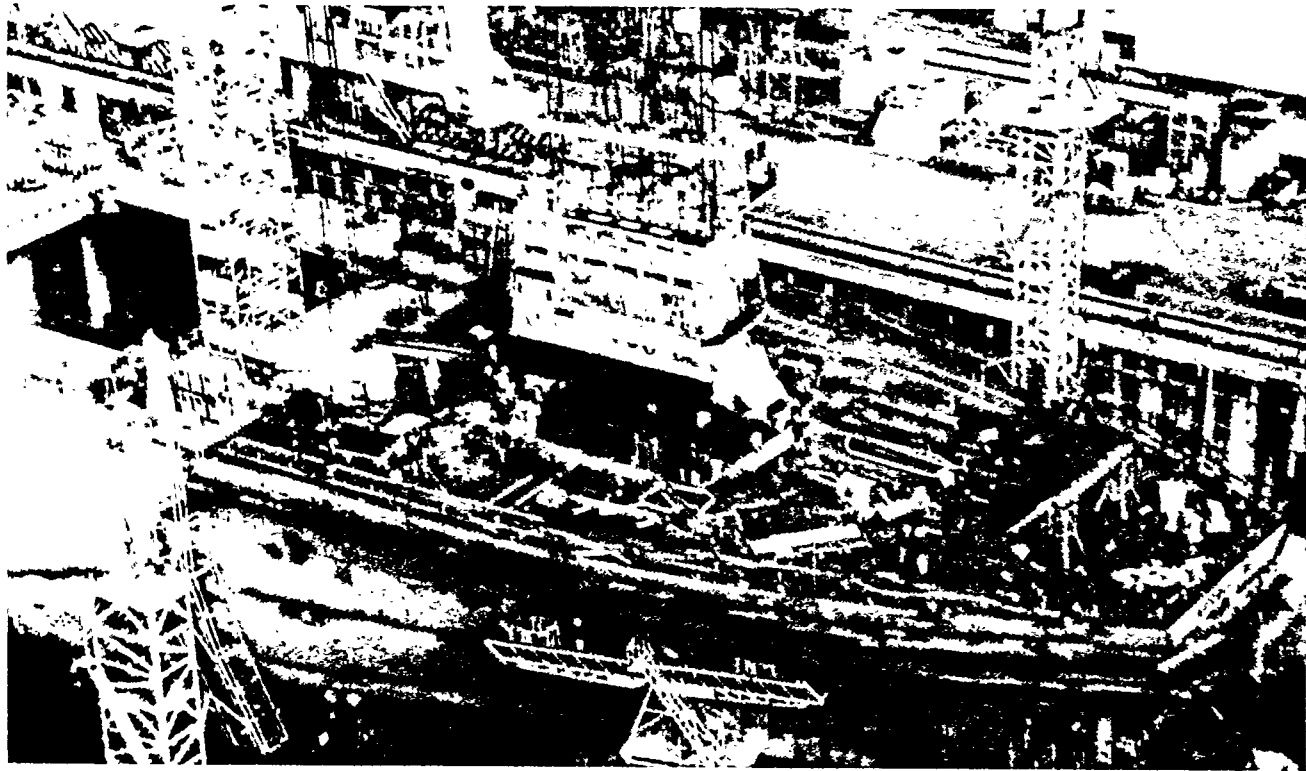
FIGURE 3-48: Erection Level. Landing the Cant Block. Finish under-coat painting was applied to ceilings of main-deck blocks before they were turned over. Keel laying plus 22 workdays.



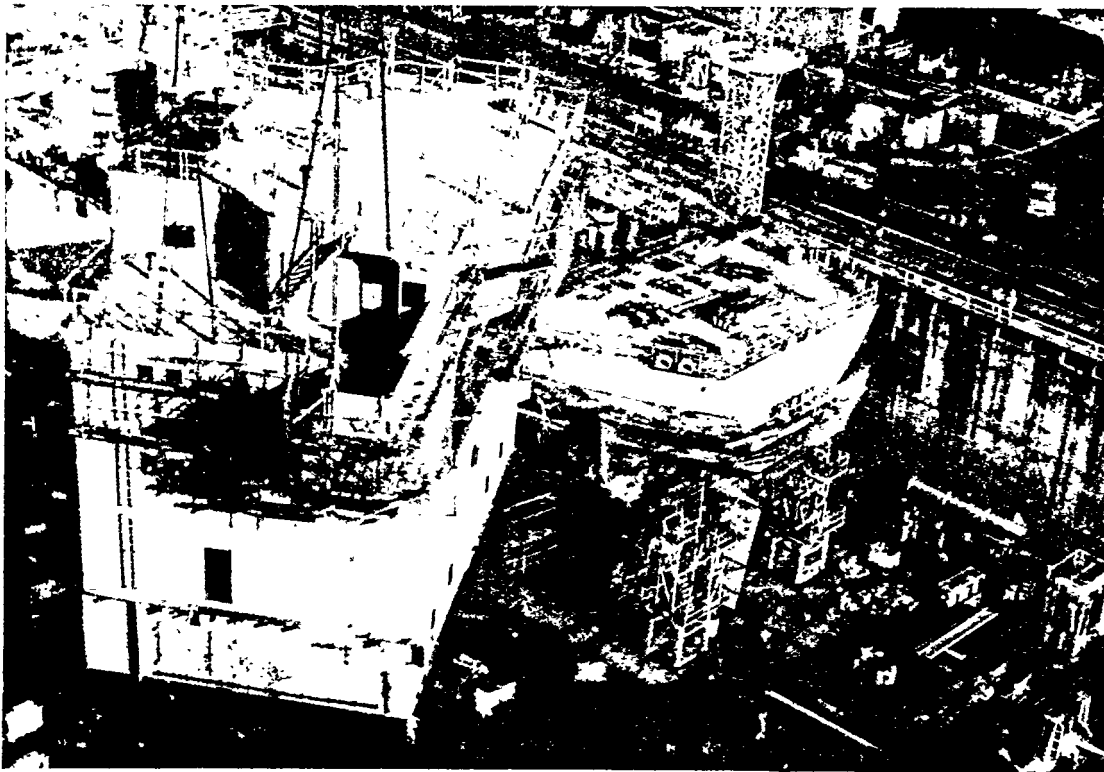
*FIGURE 3-49:* Erection Level. Landing the grand block shown in Figures 3-33 and 3-34. Keel laying plus 22 workdays.



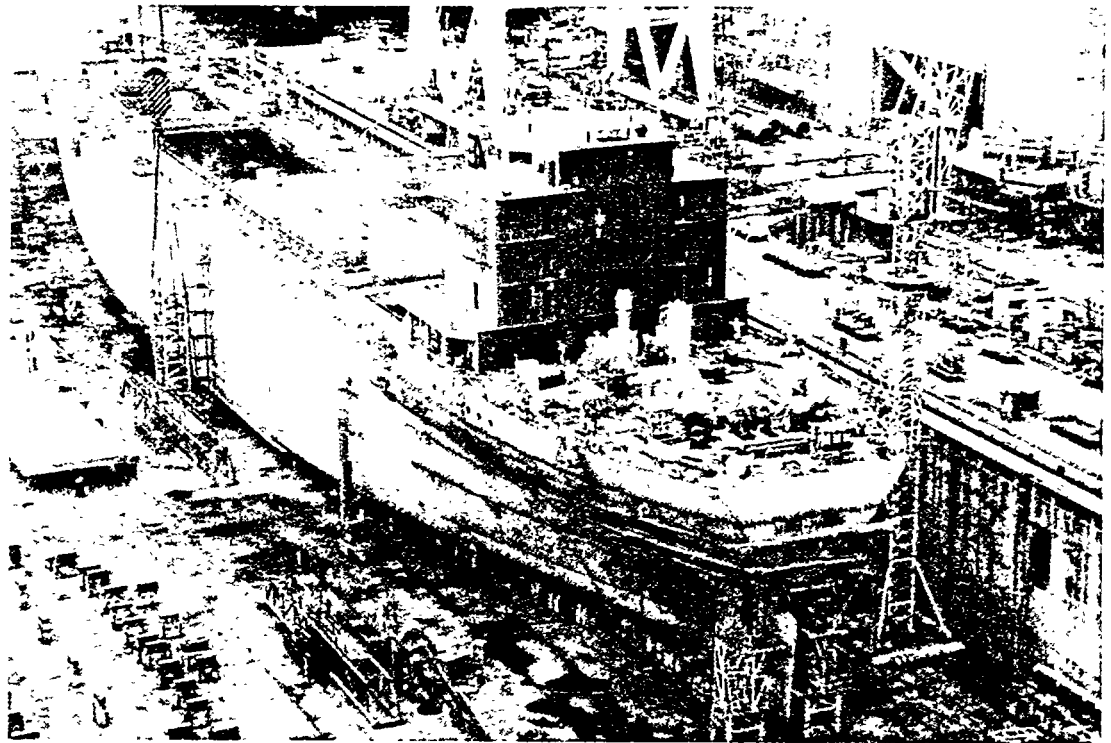
*FIGURE 3-50:* Erection Level. Keel laying plus 24 workdays.



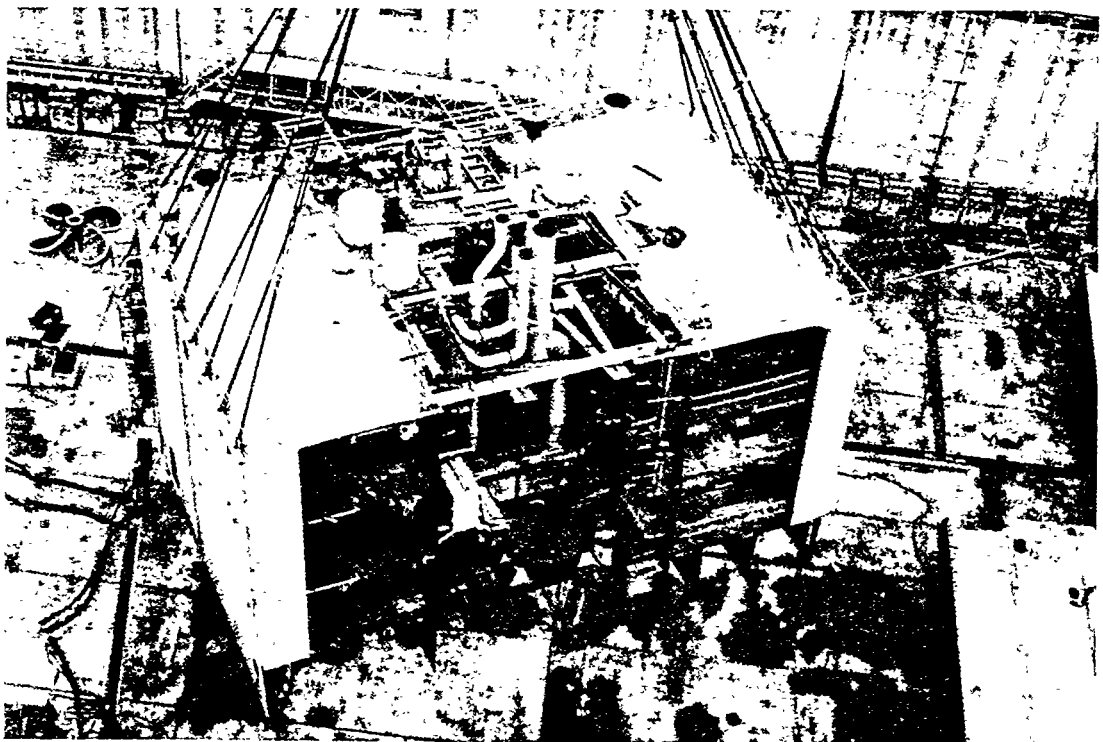
*FIGURE 3-51:* Erection Level. Landing the main engine. Stage: on-open-space fitting (blue sky fitting). Keel laying plus 24 workdays.



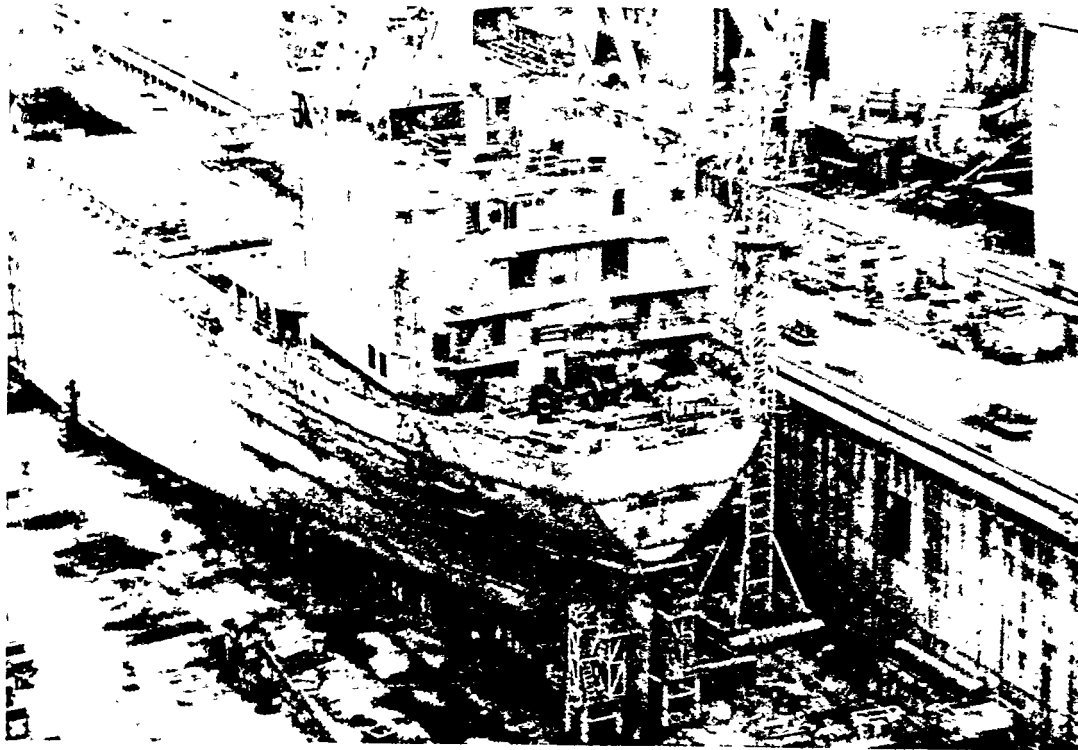
*FIGURE 3-52:* Erection Level. Landing the aft superstructure half (a grand-grand block; see Figure 3-43). Keel laying plus 27 workdays.



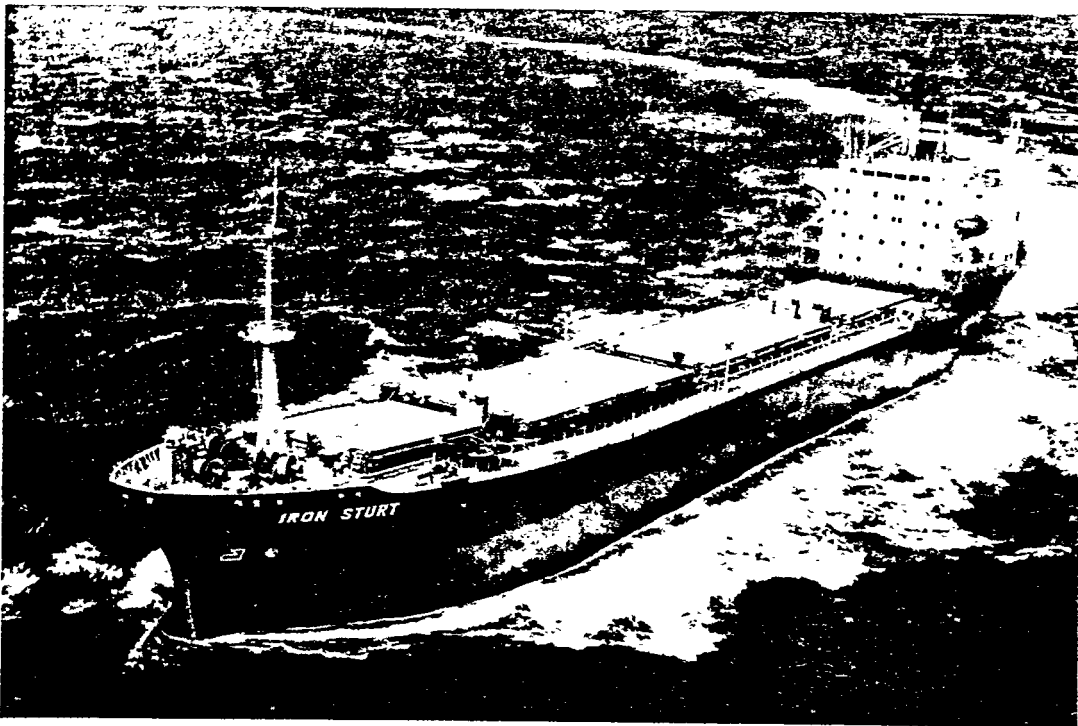
*FIGURE 3-53:* Erection Level. Finish paint was applied to the undersides of hatch-covers before the hatch cover/coaming assembly was fitted on-board. Keel plus 28 workdays.



*FIGURE 3-54:* Erection Level. Aft half of superstructure being lifted. Finish under-coat painting has been completed on all vertical surfaces. Keel plus 29 workdays.



**FIGURE 3-55:** Erection Level. Landing the aft half of superstructure on board. As described in Figure 3-43 it is a grand grand-block. Keel plus 29 workdays.



**FIGURE 3-56:** Operation and Test Level. IRON STURT Ship No. 2728, IHI Kure Shipyard. LBP — 163.0m; B — 22.9m; D — 13.6m; d — 10.0m; DWT — 22,093 metric HP — 9000. Start fabrication-18 September 1978; keel laying-5 December launching-9 February (43 workdays in building dock; shipyard was closed for 1 January holiday week); delivery 27 April 1979.



## 4.0 PIPE PIECE FAMILY MANUFACTURING

Just the engine room of a 22,000 deadweight-ton diesel-propelled ship contains about 3,600 pipe pieces. Many differences among them do not readily disclose commonalities that are useful for planning their manufacture. Group Technology (GT) is a philosophy applied by competitive shipbuilders to systematically classify pipe pieces into groups or *families* having design and manufacturing attributes which are sufficiently similar to make batch manufacturing practical. The process is called Pipe Piece Family Manufacturing (PPFM).

The collection of seemingly different pipe pieces into such families avoids laborious job-shop type planning, scheduling and manufacturing. Instead, different pieces within a family are designated for the same machines and tooling setups which are arranged in a rationalized process lane. The benefits include greater utilization of the same tool setups and simpler material handling requirements between the work stages in each process lane. The manifestly clear stage by stage progression of developing pipe pieces within such work flow lanes greatly enhances production control. Further, the separation by stages permits the switching of work flow from one process lane to another without diminishing control.

In PPFM the key zone is that which defines a planned pipe piece. It is an optimum division of a pipe line, usually consisting of:

- cut pipe (including branch when applicable),
- flanges, and/or
- elbows, sleeves, tees, etc.'

A finished pipe piece appears in Figures 3-17 and 3-18 as a component, from the "in-house manufacturing" *area* within the lowest ZOFM manufacturing level, needed for outfitting on unit, on block or on board. Thus, zone for PPFM is different from that for HBCM, ZOFM and ZPTM in that it is not derived from a hull block. Because of this difference, PPFM developed independently and is problem-area oriented as distinguished from the zone orientations of HBCM, ZOFM and ZPTM.

A further distinction is that PPFM is a fabrication process as compared to the assembly processes which characterize HBCM, ZOFM and ZPTM. Typically, PPFM is applied in the seven manufacturing levels presented in Figure 4-1. The accompanying product aspects in Figure 4-2 show that the most important considerations for grouping proposed pipe pieces by problem area must take into account similarities in:

- material specified (steel, copper, polyvinylchloride, etc.)
- bore size
- shape, i.e., straight or bent
- length
- other factors.

Horizontal combinations of the product aspects characterize the various types of work that are requisite and sufficient for the work to be performed at each level. Vertical combinations of the various work package types denote the process lanes for pipe-piece manufacturing. Typical *area* subdivisions for only the pipe fabrication, pipe piece assembly and pipe piece joining levels are presented in Figure 4-3.

The work packages, grouped by unique similarities at all levels facilitate:

- modularization of the fabrication processes, and
- justification for expensive but highly efficient facilities.

Where applied for either manual or automatic fabrication of the variety of pipe pieces needed for ships, PPFM advantages are manifested by:

- less rearrangement of jigs and tools,
- less variations in the work durations and manhours required among the same type work packages,

---

In I HI shipyards electrical conduit pieces are regarded as pipe Pieces. Thus they are included in PPFM for their manufacture and in ZOFM for outfitting on-unit, on-block and on-board just as if they were pipe pieces.

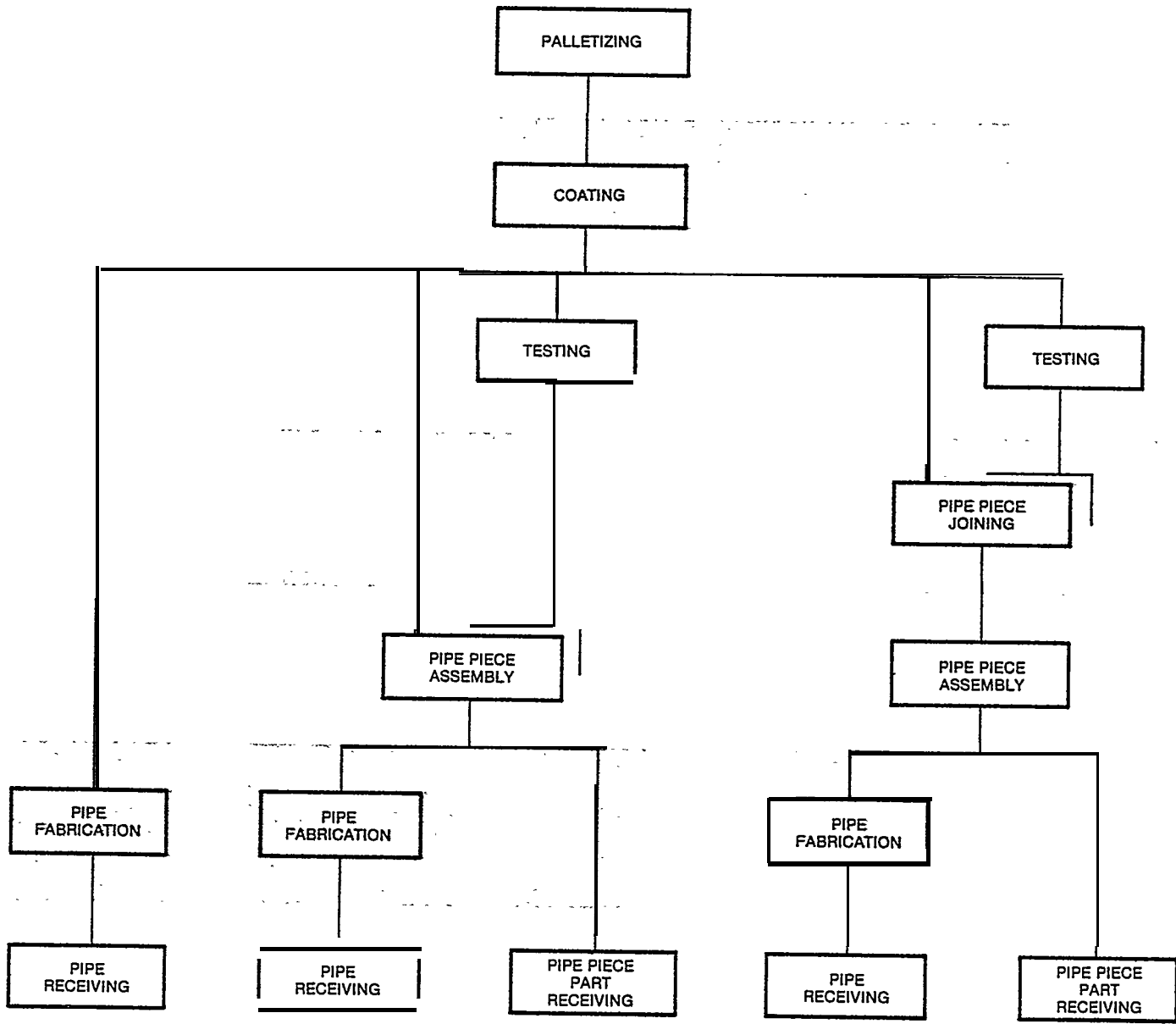


FIGURE 4-1: Typical Manufacturing Levels for the Pipe Piece Family Manufacturing Method (PPFM). Note that “Palletizing” is a manufacturing level, i.e., each pipe piece is not complete until it is grouped with other required pipe pieces for a specific pallet (zone by area by stage).



LEVEL	M'P'G LEVEL
1	7
2	6
3	5
4	4
5	3
6	2
7	1

PRODUCT ASPECTS					
ZONE		AREA		STAGE	
PALLET		DECK INCLUDING ELECTRICAL	ACCOMMODATION INCLUDING ELECTRICAL	MACHINERY INCLUDING ELECTRICAL	PALLETIZING
PIPE PIECE	NIL	COATING PROCESS		COATING	NIL
				PICKLING	NIL
		TEST PROCESS		TESTING	NIL
				FINISHING	
		PIPE MATERIAL/ X-RAY OR NIL/ BORE/STRAIGHT OR BENT/ LENGTH		WELDING	
				JOINING	
				MARKING & CUTTING	NIL
				BENDING ON PIPE PIECE	NIL
		PIPE MATERIAL/ X-RAY OR NIL/ MAIN OR BRANCH/ BORE/STRAIGHT OR BENT/LENGTH		FINISHING	NIL
				WELDING	NIL
ASSEMBLY					
CUT PIPE JOINING	NIL				
CUT PIPE	NIL	PIPE MATERIAL/PIPE MAIN OR BRANCH/ BORE		MACHINING	NIL
				BENDING ON CUT PIPE	NIL
		MARKING & CUTTING			
MATERIAL	PIPE	PIPE PIECE PART	RECEIVING		

CODES					
MATERIAL CODE		PIPE PIECE NO.	PIPE PIECE NO./ MAIN OR BRANCH SIGN	PIPE PIECE MANUFACTURING LANE CODE	PIPE PIECE MANUFACTURING LANE CODE
MATERIAL CODE		PALLET CODE	PIPE PIECE NO.	PIPE PIECE MANUFACTURING LANE CODE	PIPE PIECE MANUFACTURING LANE CODE
MATERIAL CODE		AREA	COATING CODE	PIPE PIECE MANUFACTURING LANE CODE	PIPE PIECE MANUFACTURING LANE CODE
NIL		SHOP NO.	COATING CODE	PIPE PIECE MANUFACTURING LANE CODE	PIPE PIECE MANUFACTURING LANE CODE
NIL		SHOP NO.	COATING CODE	PIPE PIECE MANUFACTURING LANE CODE	PIPE PIECE MANUFACTURING LANE CODE
NIL		STAGE	COATING CODE	PIPE PIECE MANUFACTURING LANE CODE	PIPE PIECE MANUFACTURING LANE CODE

FIGURE 4-2: Typical classifications of product aspects for the Pipe Piece Family Manufacturing Method (PPFM).

LEVEL	PIPE PIECE JOINING						
	PIPE PIECE ASSEMBLY						
		PIPE FABRICATION					
AREA	MATERIAL	X-RAY OR NIL	MAIN OR BRANCH	BORE	STRAIGHT OR BENT	LENGTH	
SUB-AREA	STEEL	NIL	MAIN	SMALL	STRAIGHT		
					BENT		
				MEDIUM	STRAIGHT	SHORT	
					BENT*	LONG**	
				LARGE	STRAIGHT	SHORT	
					BENT*	LONG**	
	BRANCH						
	x-RAY						
	NONFERROUS						
	PVC						
	OTHER						

FIGURE 4-3: Problematic subdivisions for Pipe Fabrication, Pipe Piece Assembly, and Pipe Piece Joining Levels only. Blank spaces indicate that no further subdivision exists. ● Medium and large bore pipe pieces to be bent can be assigned the same area subdivision. ● \*Similarly, long, medium and large bore pipe pieces can be assigned the same area subdivision.

MANUFACTURING METHOD	WORKING HOURS PER WORK PACKAGE	NUMBER OF WORK PACKAGES PER WORK LOT
PPFM	PRACTICALLY EQUAL	MANY
HBCM	VARIABLE	ONE
ZOFM	VARIABLE	ONE
ZPTM	VARIABLE	ONE

FIGURE 4-4: Differences in Grouping PPFM Work as Compared to Other Manufacturing Methods.

- better accuracy, and
- significant manpower savings.

#### 4.1 Work Lots

It is impractical to control PPFM with one work package per pipe piece because each is a relatively small job and a wide variety and large number of pipe pieces are needed per ship. Control by lot, i.e., a group of work packages, is far more effective provided certain principles are applied.

Within a processing lane the optimum durations required for each work stage and the times required for material handling between stages, when summed, yield the overall duration (lead time) required for a processing lane. Thus, minimizing the time required for material handling between stages also requires careful attention. Further, the durations required to manufacture all pipe pieces of a particular family should be equal to each other. These principles permit the grouping of pipe pieces into a lot, i.e., an ideal mix from different families that will fully load a facility during a designated period (work day, work week, etc.). Thus, pipe pieces which comprise a lot could be manufactured in any random sequence without diminishing control. A lot should be sized by evaluating its Productivity Value (PV), particularly in consideration of its product resources.<sup>2</sup>

Figure 4-4 shows the basic differences between work grouped for PPFM as compared to work grouped for HBCM, ZOFM and ZPTM.

#### 4.2 Material Receiving

Material receiving is the preparation, or first manufacturing, level as shown in Figures 4-1 and 4-2. Problem *area* is grouped by types of material in accordance with the following:

- pipe
- flanges, elbows, tees, sleeves, etc.

*Stage* is simply:

- material receiving.

#### 4.3 Pipe Fabrication

Pipe fabrication, the second manufacturing level, applies to processing of the pipe only, i.e., processing of the main part of the finished pipe-piece zone. Problem *area* is grouped by:

- pipe material (steel, non-ferrous, polyvinylchloride, etc.)
- main pipe or branch
- bore (small, medium, or large).

These *area divisions* and further subdivisions are incorporated in Figure 4-3.

*Stages* are phased for this level as:

- marking and cutting
- bending of cut pipe or nil
- machining or nil.

Preferably, bending should be deferred for the next manufacturing level because it is easier to attach flanges or sleeves to straight pipe. The bending stage at the pipe fabrication level is only for those exceptional cases where flanges would lose their required orientations during bending. The machining process applies to the preparation of pipe ends for welded or threaded joints.

#### 4.4 Pipe Piece Assembly

At this level flanges, sleeves, etc. are attached to cut pipe. The finished assembly is the zone for a pipe piece except for main and branch subassemblies which are to be joined to create a branch pipe piece during the next manufacturing level.

*Area* is subdivided as follows:

- x-ray test or nil
- short straight (5.5 meters or less) or bent
- long straight (over 5.5 meters).

*Stage* is phased in accordance with the following sequence

- cut pipe joining or nil
- assembling
- welding or nil
- finishing (grinding or machining) or nil
- bending or nil.

Cut pipe joining is for producing a cut pipe longer than a standard length of 5.5 meters. The welding and finishing stages for main and branch subassemblies are deferred until after they are joined to create a branch pipe piece during the next manufacturing level. Grinding on non-tested pipe pieces and machining on pipe pieces to be x-ray tested or on pipe for hydraulic systems, are deferred for accomplishment during the next manufacturing level.

<sup>1</sup>One very effective manually operated pipe shop posts a large calendar marked to show a color code assigned to each work week. A dab of paint marks each pipe piece in process with a color assigned per work lot. Thus, anyone can readily determine if the lot in process is on schedule.

#### 4.5 *Pipe Piece Joining*

The pipe piece joining level is for performing all joining not previously accomplished. Typically, it would apply to joining a main pipe subassembly to a branch pipe subassembly or to other parts such as elbows, tees, sleeves, etc. Thus, the pipe pieces finished at this level are neither simple or straight.

Area is grouped identical to that for the previous manufacturing level except that the “main or branch” subdivision shown in Figure 4-3 is not required.

*Stage is* phased as:

- marking and cutting or nil
- joining
- welding
- finishing (grinding or machining).

The marking and cutting stage at this level pertains to boring a hole in a main pipe subassembly as preparation for joining a branch.

#### 4.6 *Testing and Coating*

Testing and coating are performed at the places where each pipe piece first constitutes a zone. This means places where final work for pipe piece assembly (straight or simple) and pipe piece joining (branches, etc) are performed.

*Area* for testing is grouped by the different test processes required.

*Stage is* simply:

- testing or nil.

*Area* for coating is grouped by the different coating processes required.

*Stage is* phased as:

- pickling or nil
- coating or nil.

#### 4.7 *Palletizing*

Palletizing is the final manufacturing level and provides for the sorting of all pipe pieces (including electrical conduit) in accordance with structured material lists. Each list establishes the pipe piece requirements for a specific pallet, i.e., the pipe pieces required to outfit on-unit, on-block or on-board during a specific stage.

Problem *areas* for palletizing are

- deck
- accommodation
- machinery.

*Stage is* simply

- palletizing.

## 5.0 PRODUCT RESOURCES

In PWBS, product resources are the inputs to work packages, each of which can address a specific zone containing portions of a number of systems. Thus, resources are defined by zone. For the purposes of estimating and early material procurement, it is also necessary to identify material requirements by systems.

### 5.1 Material

Material is readily listed-by system from diagrammatics and also by zone/area/stage from working drawings. However, planning is not complete until each required item is assigned a:

- **Material Code Number** which designates type, grade size, etc. (for identification in procurement),
- **Material Cost Classification Number** which identifies a particular system and material family (for material-cost control),
- **Piece Number** which identifies, by unique serial number per system, where the item will appear (for identification in design), and a
- **Work Package Number** which identifies its end use by zone/area/stage of a specific level of a specific manufacturing method for a specific ship (for issue control).

Figure 5-1 shows how the foregoing material codes differ in their definition content because of differences in:

- Type of work, i.e., hull construction, outfitting or painting,
- Commonness, e.g., for hull construction, shipbuilding grade vs. special materials; for outfitting, materials commonly used in several systems (e.g., piping, access, ventilation or raw materials) vs. materials used only in one system,

Ž Requisition Classification, i.e.:

- Allocated (A) - requisitioned per ship in the exact quantity defined in design,

- Stock (S) - requisitioned for all ships in economic quantities based upon past usage and forecasts of future needs, and

- Allocated Stock (AS) - requisitioned per ship in the quantity defined in design plus a contingent amount added in material control based upon a history of problems, and

- Standardization, i.e.:

- for hull construction, shipbuilding grade material is of unique size per sketch (Sketch Size), of a standard size commonly used within a specific ship (Standard Within a Ship), or of standard size generally used in any type ship (Standard).

Regarding Standardization, any shipbuilding grade plate, angle, etc. for hull construction is sufficiently identified for procurement by material/grade/size. However, the same approach for all other materials would lead to voluminous purchase specifications. As shown in Figure 5-1 for outfitting and painting, materials designated “individual” are identified one-by-one with an appropriate full description for each. They are materials generally used in any type of ship. Other materials designated “family” are grouped in order to relate them by general characteristics. Except for two or three traits, a single description identifies all materials within a family.

Materials classified as “individual” are defined one-by-one in purchase specifications. Those classified as “family”, are defined family-by-family with unique traits separately defined. For example, certain valves are defined by family and their specific sizes and/or design pressures are incorporated in purchase specifications.

Designating system in each outfitting and painting material code, as shown in Figure 5-1, is useful because it facilitates standardization in material definition, cost classifications, etc. As also shown, it remains blank for common materials until their system designations become known.<sup>1</sup>

---

<sup>1</sup>“system” as used for material identification is slightly different from system of the Product Aspects. “System,” for example, includes components which make up a pipeline less machinery items, and anything else omitted for estimating convenience. System of the Product Aspects includes everything needed for designing and producing and applies to identification in a ship.

MATERIAL IDENTIFICATION FOR PROCUREMENT					MATERIAL IDENTIFICATION FOR DESIGN & PRODUCTION
WORK TYPE	COMMONNESS	REQUISITION CLASSIFICATION	STANDARDIZATION	MATERIAL CODE	SHIP PIECE NO.
HULL CONSTRUCTION MATERIAL	SHIPBUILDING GRADE	AS	SKETCH SIZE	MATERIAL/GRADE/SIZE	SHIPBLOCK, SEMI-BLOCK, OR SUB-BLOCK/PART CODE
			STANDARD WITHIN A SHIP		
STANDARD					
	OTHER	SAME AS OUTFITTING			
OUTFITTING & PAINTING MATERIAL	COMMON WITHIN SHIP	AS&S	INDIVIDUAL	BLANK/FULL DESCRIPTION	SHIP/SYSTEM/PART NO./ COMPONENT CODE (FOR OUTFITTING ONLY)
			FAMILY	NIL	
		A	INDIVIDUAL	BLANK/FULL DESCRIPTION	
			FAMILY	BLANK/FULL DESCRIPTION	
	UNCOMMON WITHIN SHIP	AS&S	INDIVIDUAL	SYSTEM/FULL DESCRIPTION	
			FAMILY	NIL	
		A	INDIVIDUAL	SYSTEM/FULL DESCRIPTION	
			FAMILY	SYSTEM/FAMILY DESCRIPTION	

FIGURE 5-1: Identification Codes for Material.

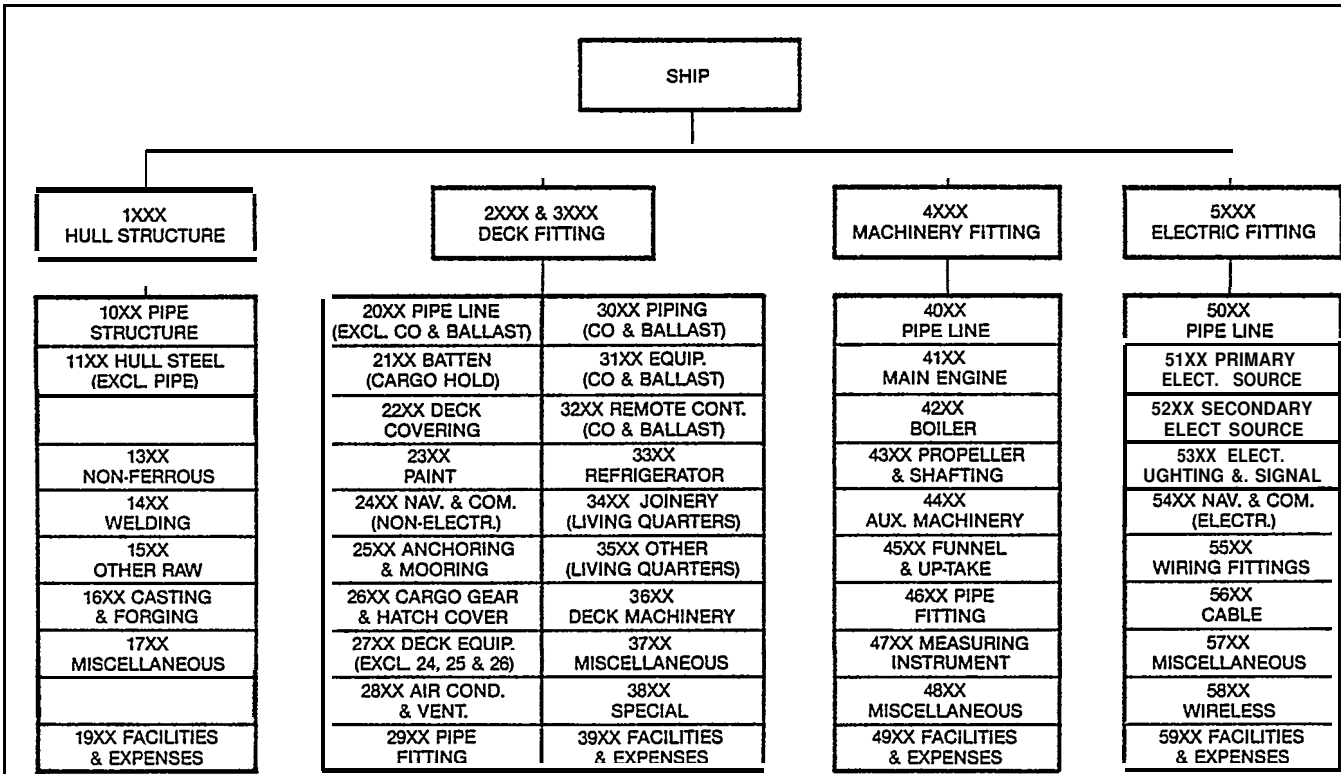


FIGURE 5-2: Typical Structure for Material Cost Classification. Except for Hull Structure, four digits are the system portion of the material code described in Figure 5-1. "XX" of 3rd and 4th digits indicates a family material code.

Part and component codes respectively identify hull and outfit *assembly* zones which are not further subdivided. Thus, they apply to purchased interim products and those manufactured in-house or by a subcontractor.

As shown in Figure 5-1, composition of a Ship Piece Number *for hull construction* is hierarchically configured as: Ship No./Block Code, Semi-block Code or Sub-block Code/Part Code. Whenever a specific manufacturing level is bypassed, its code is not included. Conversely when a part is added as an exception, see Figure 3-11, a Grand-block Joining Code is incorporated.

The Part Code should at least contain the following information:

- parent block,
- system (bulkhead, deck, longitudinal, etc.), and
- unique serial number.

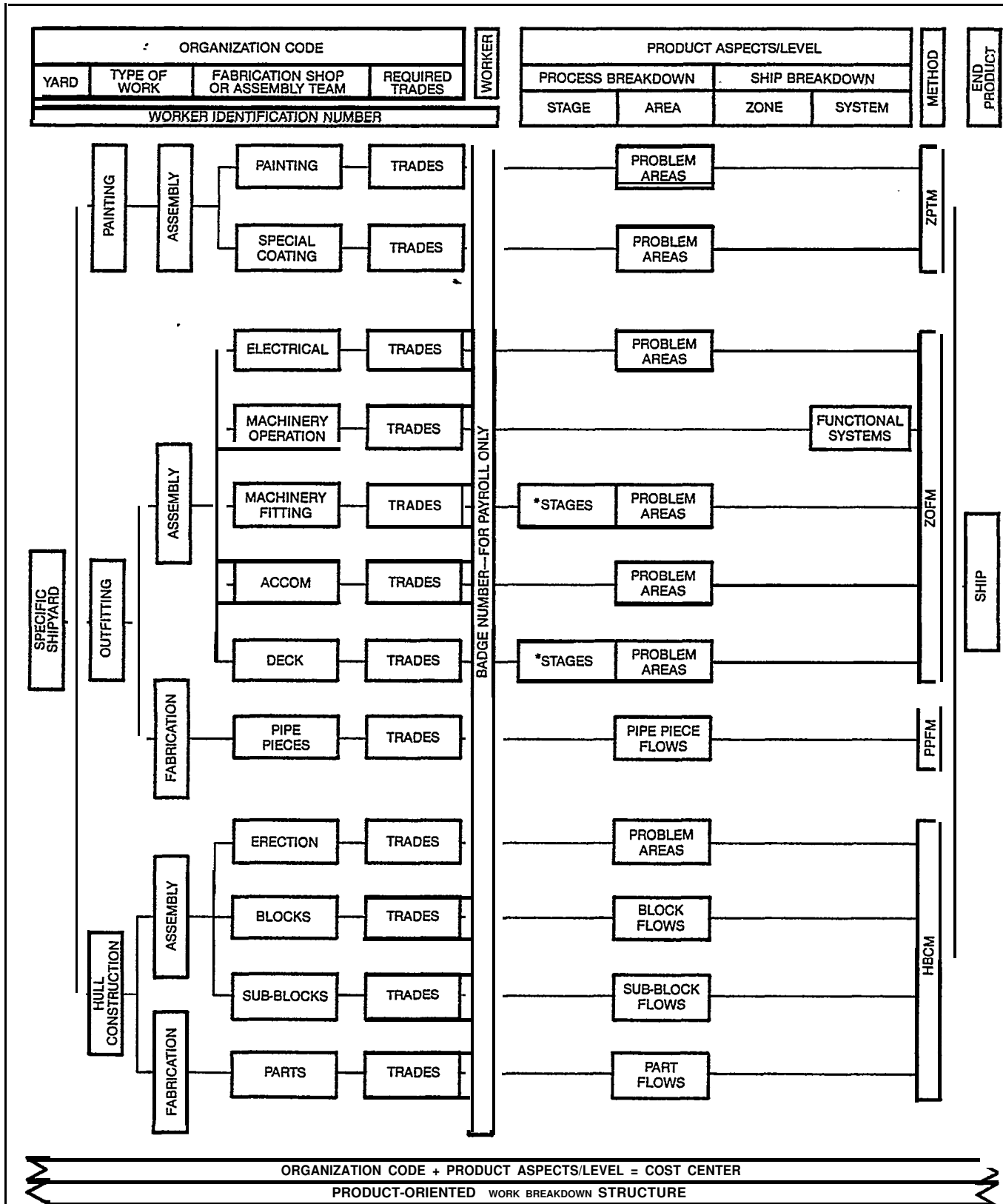
As it facilitates fabrication-shop planning, it is advisable to also include in the Part Code:

- raw-material type, and
- part shape.

Each Part Code appears in a hull-block parts list, a cutting plan and in a subassembly or assembly plan as appropriate; see Figure 2-2. Thus, all “what”, “where”, “how” and “when” questions are anticipated by completely defined product aspects, i.e., system/zone/area/stage.

The elements of the Ship Piece Number for *outfitting*, as shown in Figure 5-1, are: Ship No./System Code/Part No./Component Code. The System Code combined with the Component Code, comprise a Material Cost Classification as illustrated in Figure 5-2. The System Code combined with a Part No., provide relative positions of pieces (finished interim products only) identified in a system diagrammatic. Actual positions of pieces are as shown in each fitting drawing per zone/area/stage see Figure 2-2. Thus, all questions pertaining to outfitting are also anticipated by completely defined product aspects.

The identification codes presented in Figure 5-1 and described in the foregoing, permit each material item to be assigned to both a system-oriented material-control group and a zone-oriented material-control group. With reference to Figure 2-1, a work-package number is used for zone-oriented material control during planning, scheduling, execution and evaluation. A material cost classification number controls the same material by system for evaluation, estimating and planning. The combined use of a material code and a ship piece number permits transformations from zone-oriented to system-oriented data and vice versa.



**FIGURE 5-3:** Typical Cost Centers are separately depicted by the horizontal combinations on each line. Cost centers shown *exactly march the* shipyard organization. With few exceptions, the yardsticks used for performance measurement are based upon work packages grouped by problem area per level. Yardsticks are whatever best suits circumstances at each manufacturing level. \*Control by stage is added only when there are special or extensive welding requirements. Otherwise, welding incident to normal fitting is performed by fitters; control by problem area is sufficient.



**5.2 Manpower**

In PWBS, manpower is readily assigned by zone, which permits immediate association of man-hours allocated with those charged for manufacturing an interim product. But, reliance on such comparisons for performance measurement is avoided because:

- as there are many work packages, there would be an enormous amount of information generated which would obscure significant trends,
- there is a need to provide for both area- and system-oriented work packages in addition to those which are zone-oriented,
- different performance standards, reflecting normal throughput, are required to separately address even identical types of work at different manufacturing levels, and

an enormous effort would be required to convert "zone- or area-oriented" costs to costs by system as needed for estimating.

Because of the foregoing, manpower charges are analyzed in accordance with a **Cost Center** concept derived from the inherent applicability of PWBS to all industrial situations. Manpower charges are identified by:

- **Organization Code** which indicates the grouping of workers by shipyard (in firms that have more than one), by type of work, by fabrication shop or assembly section, and by trade,
- **Badge Number** which is a serial number assigned to identify each worker for payroll purposes only,
- **Work Package Number** which identifies a manpower allocation by zone/area/stage for a specific: type of work, manufacturing level, and ship, and
- **Cost Center Code** (Manpower Cost Classification) which identifies the total manpower charges for a number of work packages grouped per level by similarities in select combinations of product aspects (Control Group).

Typical such cost centers, which *exactly match* a shipyard organization, are shown in Figure 5-3. They feature primary dependence on collecting manpower charges from a number of work packages that are separated only by problem area per manufacturing level. The charges so collected are compared to yardsticks for progress and efficiency which themselves have been statistically determined from a history of such charges. Typical yardsticks which are the bases for judgement during performance evaluations, are shown in Figure 5-4.

			MANPOWER EXPENDITURE INDEX	PRODUCTION PROGRESS INDEX	PRODUCTIVITY INDEX	
TYPE OF WORK	HULL CONSTRUCTION	FAB	MHRS/UT	FABRICATED WT/UT	MHRS/FABRICATED WT	
		ASSEMBLY	SUB-ASSEM	"	SUBASSEMBLY WT/UT SUBASSEMBLY Wp/UT	MHRS/SUBASSEMBLY WT SUBASSEMBLY Wp/MHR
			ASSEM	"	ASSEMBLY WT/UT ASSEMBLY Wp/UT	MHRS/ASSEMBLY WT ASSEMBLY Wp/MHR
			ERECT	"	ERECTED WT/UT ERECTED Wp/UT	MHRS/ERECTED WT ERECTED Wp/MHR
	OUTFITTING	FAB	PPFM	"	MANUFACTURED WT/UT MANUFACTURED PIECES/UT	MHRS/MANUFACTURED WT MHRS/MANUFACTURED PIECES
		ASSEMBLY	DECK	"	PARAMETRIC-COMPONENT WT/UT	MHRS/PARAMETRIC-COMPONENT WT
			MACH	"	"	"
			ACCOM	"	"	"
			ELECT	"	LAID CABLE LENGTH/UT CONNECTED CABLE PIECES/UT PARAMETRIC-COMPONENT WT/UT	MHRS/LAID CABLE LENGTH MHRS/CONNECTED CABLE PIECES MHRS/PARAMETRIC-COMPONENT WT
	PAINT	ASSEM	I	"	COATED SQUARE METERS/UT	MHRS/COATED SQUARE METER

**FIGURE 5-4:** Indices for Monitoring Man-hours Spent, Progress and Productivity. MHR: man-hour. UT: unit time. WT: weight. Wp: a parametric length for welding which takes into account weld size, type and position. Parametric-component WT: weight of only fittings for which the ratios WT/UT and MHRS/WT remain almost constant. The indices for Pipe Piece Family Manufacturing (PPFM) are applied separately to each flow lane.

### 5.3 Facilities and Expenses

Facilities and expenses are product resources of a second order as compared to material and manpower. The cost classifications and charging methods described in Figure 5-5 are commonly applied by many shipyards.

Direct costs are those that can be related to specific interim products. Indirect costs are not so identifiable. Therefore, at regular time intervals, forecasts of all indirect costs to support a group of work packages, e.g., those for a manpower cost-center, are applied as overhead to the cost center using predicted direct man-hours as the basis for such apportionments. If there is no difference among apportionments, it is prudent to apply a forecast of summarized overhead charges to a higher level control group.

	COST CLASSIFICATION		CHARGING METHOD
	FACILITIES	EXPENSES	
DIRECT COSTS	<p>DEPRECIATION FOR OWNED:</p> <ul style="list-style-type: none"> <li>—DOCKAGE</li> <li>—TUGBOATS</li> <li>—FLOATING CRANES</li> <li>—ETC.</li> </ul> <p>RENTAL FEES FOR:</p> <ul style="list-style-type: none"> <li>—DOCKAGE</li> <li>—TUGBOATS</li> <li>—FLOATING CRANES</li> <li>—ETC.</li> </ul>	<p>CHARGES FOR:</p> <ul style="list-style-type: none"> <li>—SEA TRIALS</li> <li>—CEREMONIES</li> <li>—CONSTRUCTION INSURANCE</li> <li>—ETC.</li> </ul>	<p>DIRECTLY CHARGED TO A SPECIAL MATERIAL COST CLASSIFICATION; SEE 19XX, 39XX, 49XX AND 59XX IN FIGURE 5-2.</p>
INDIRECT COSTS	<p>DEPRECIATION FOR OWNED:</p> <ul style="list-style-type: none"> <li>—BUILDINGS</li> <li>—MACHINES</li> <li>—VEHICLES</li> <li>—ETC.</li> </ul> <p>CHARGES FOR:</p> <ul style="list-style-type: none"> <li>—CONSUMABLE TOOLS</li> <li>—ETC.</li> </ul>	<p>CHARGES FOR:</p> <ul style="list-style-type: none"> <li>—FRINGE BENEFITS</li> <li>—COMMUNICATIONS</li> <li>—TAXES</li> <li>—MAINTENANCE</li> <li>—POWER</li> <li>—ETC.</li> </ul>	<p>CHARGED MONTHLY TO EACH COST CENTER PER AN INDIRECT-COST RATE WHICH IS A FORECAST OF TOTAL INDIRECT COSTS DIVIDED BY A FORECAST OF TOTAL DIRECT MANHOURS.</p>

FIGURE 5-5: Cost Classifications and Charging Methods for Facilities and Expenses.

## 6.0 EVALUATION AND FEEDBACK TO ESTIMATING

The management cycle, Figure 6-1, incorporates transformations of system- and zone-oriented data in both the planning and evaluation functions. As shown in Figure 2-2, people who perform design and material definition are *the planners* who make initial transformations. However, they are very dependent on feedback from field engineers. This interaction between design and production specialists is essential for defining ideal work packages by zone, area and stage that uniformly load integrated work processes such as those shown in Figure 2-4.'

While such zone-oriented work is in-progress, there is need for evaluation which involves sorting, analyzing and reorganizing performance data collected by control groups in order to:

- monitor manhours spent, production progress and productivity, and
- feedback system-oriented data for estimating potential shipbuilding projects.

For these purposes, it is sufficient to address only *manpower* among the product resources. This is because *material is* identified both by system and zone, and *facilities* and *expenses are* charged as overhead on direct material and manpower accounts. Thus, the practical indices shown in Figure 5-4, for monitoring man-hours spent, progress and productivity, are sufficient.

### 6.1 Man-hour Expenditures

The character of the manpower index, i.e., man-hours per unit time, is the same for the various control groups of work packages which apply to all work categories. Typical accumulations of data recorded accordingly, are provided in Figures 6-2 through 6-5. The plotted curves indicate *actual* manpower costs but only *apparent* progress.

### 6.2 Production Progress

As shown in Figure 5-4 the indices for production progress use different means of measure (weight, welding

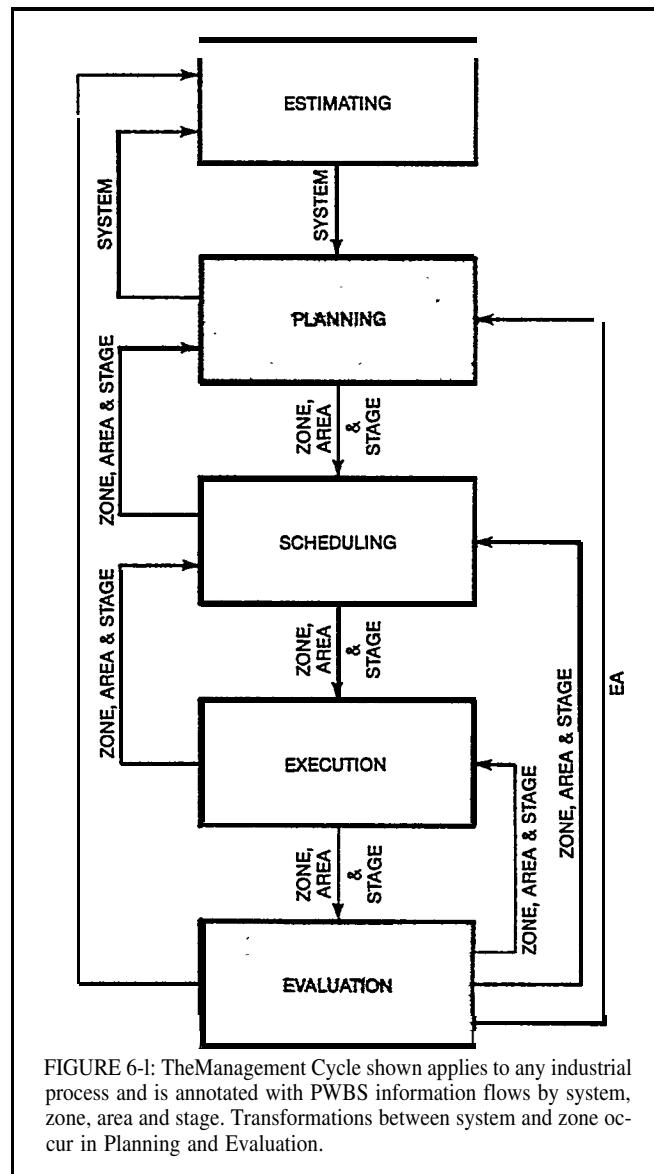


FIGURE 6-1: The Management Cycle shown applies to any industrial process and is annotated with PWBS information flows by system, zone, area and stage. Transformations between system and zone occur in Planning and Evaluation.

Achieving the needed work balance is facilitated by adapting zone, area and stage classifications (a pallet list) from a previously built ship. This permits creating coordinated schedules for material procurement (including interim products), manning, and working drawings very soon after contract award.

parameters, laid cable length, etc.) per unit time. Further, it is sometimes necessary to apply more than one for each control group of work packages. Accumulations of such data as illustrated in Figure 6-6, reflect *real* progress. When compared to pertinent schedules, they are the bases for short term adjustments, e.g., shifting workers, using overtime, etc. When the manpower cost-centers exactly match the shipyard organization, as shown in Figure 5-3, it is practical to delegate such control to the managers of fabrication shops and assembly sections.

### 6.3 Productivity

Productivity indices, as shown in Figure 5-4, utilize both manhours expended and the measures used for monitoring production progress, i.e., weight, welding parameters, laid cable length, etc. Typical plots of data so recorded are incorporated in Figures 6-7 through 6-11 relative to established efficiencies. Each of the latter is usually an average based upon the performance history associated with a specific control group of work packages. Any curve which appears above its efficiency reference indicates man-hour expenditures at an above average rate.

Productivity evaluations can be simplified by a Productivity-control Group (PCG) concept. It eliminates consideration of specific product aspects and is practical provided:

- each PCG corresponds to a specific manpower-control group, and
- the same indices for manpower expenditures, progress and productivity apply within each manufacturing level.

An example of a PCG is illustrated in Figure 6-12. Product aspects are disregarded because work packages are planned so that their efficiency values, for normal productivity, fall within a specified allowable range per manufacturing level.

The PCG concept is another example of inherent versatility in a product-oriented work breakdown. When there are unusual problems (e.g., because of new facilities or over expenditures of manpower), more control is applied by using the best suited combination of product aspects. Conversely, during routine operations the simpler PCG approach is more practical.

### 6.4 Zone to System Transposition

The productivity indices are useful for transposing manpower expenditures for zone-oriented work to the system-by-system data needed for estimating. In PWBS, man-hour expenditures can be collected by different methods for grouping work packages depending on the degree of control required. These vary from any combination of trade, manufacturing level, system, zone, area and stage, as shown in Figure 5-3, to a simple Productivity Control Group (PCG) as in Figure 6-12.

Further, there is need to separately address each material item for which there is no correlation between its weight and required fitting man-hours (e.g., a main engine, boiler, hatch cover, etc.). The fitting of each such "non-parametric" item is the subject of a separate work package. This permits the collection of man-hour expenditures per component which is immediately identifiable with a system.

Thus, in consideration of the two sources of zone-oriented data, i.e., parametric and non-parametric man hours, the total man-hours apportioned to a system can be expressed by the formulas:

$$(1) H_t = H_p + H_c$$

where

$H_t$  = total man-hours

$H_p$  = total parametric man-hours

$H_c$  = total non-parametric man-hours

$$(2) H_p = \sum e_i v_i = e_1 v_1 + e_2 v_2 + \dots$$

where

$e$  = a productivity index for a control group Of work packages

$v$  = pertinent description of that part of a system included in a control group of work packages, e.g., assembly weight, length of weld, manufactured pieces, parametric-component weight, laid cable length, etc. ( $\sum v_i$  describes the entire system)

$i$  = the number of work-package control groups in which a system is represented

$$(3) H_c = \sum h_j = h_1 + h_2 + \dots$$

where

$h$  = man-hours for fitting a non-parametric component

$j$  = the number of non-parametric components

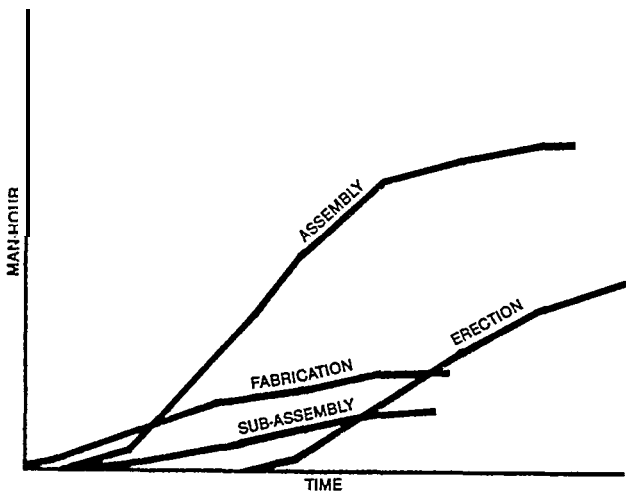


FIGURE 6-2: Manpower Expenditures-Hull Construction.

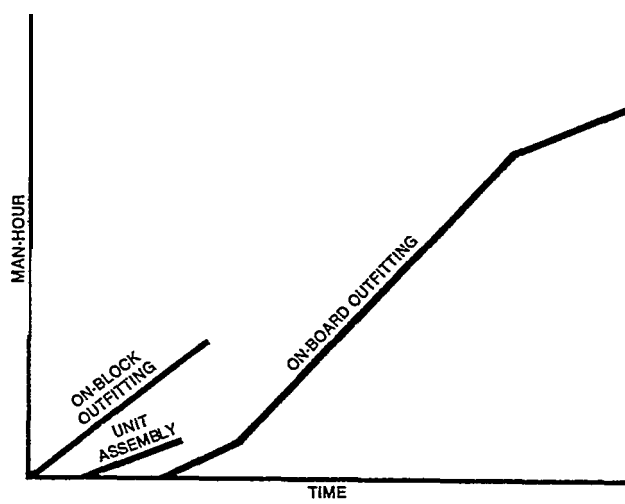


FIGURE 6-3: Manpower Expenditures-Machinery Fitting.

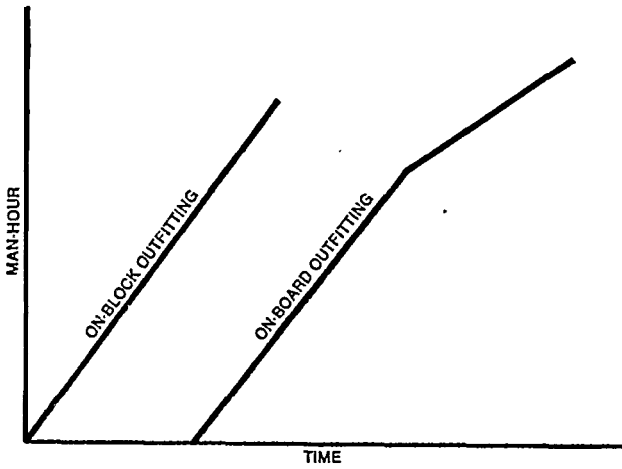


FIGURE 6-4: Manpower Expenditures-Electrical Assembly of All Components Except Cable.

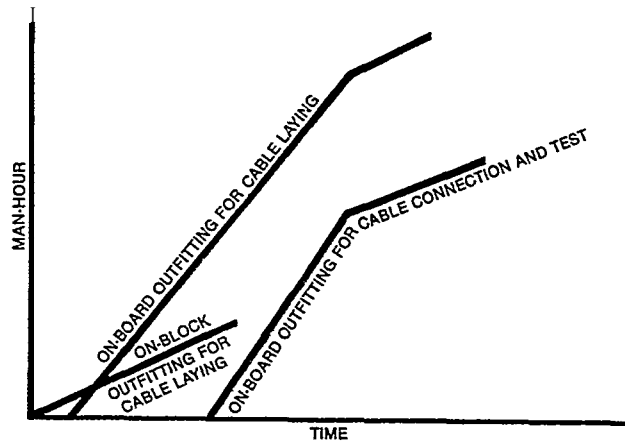


FIGURE 6-5: Manpower Expenditures-Electrical Assembly of Cable.

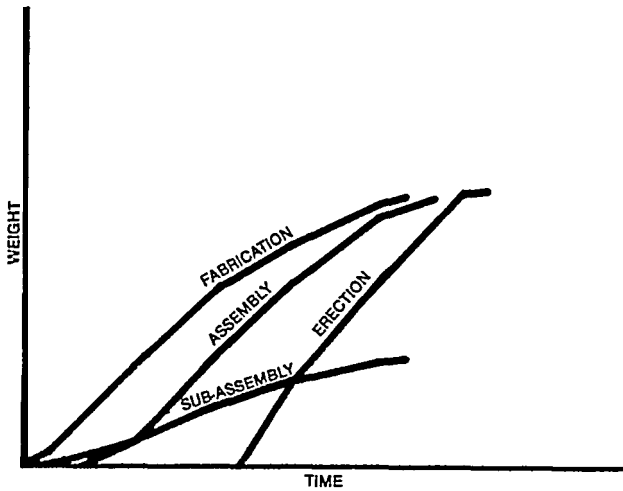


FIGURE 6-6: Production Progress-Hull Construction.

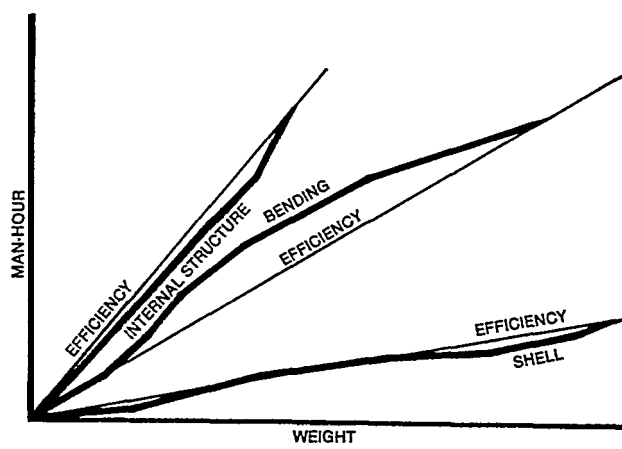


FIGURE 6-7: Productivity-Parts Fabrication. The plot for bending is by stage. The other two are by problem area. This illustrates the versatility of PWBS for fulfilling practical needs.

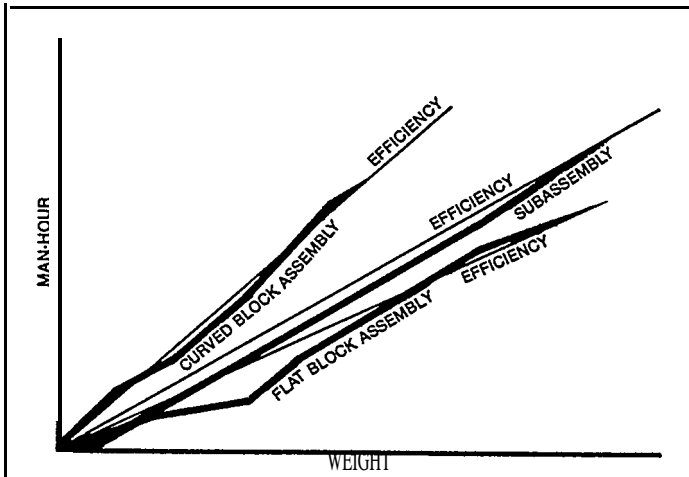


FIGURE 6-8: Productivity-subassembly and Block Assembly. The curved-block and flat-block plots are by problem area. The subassembly plot is by level.

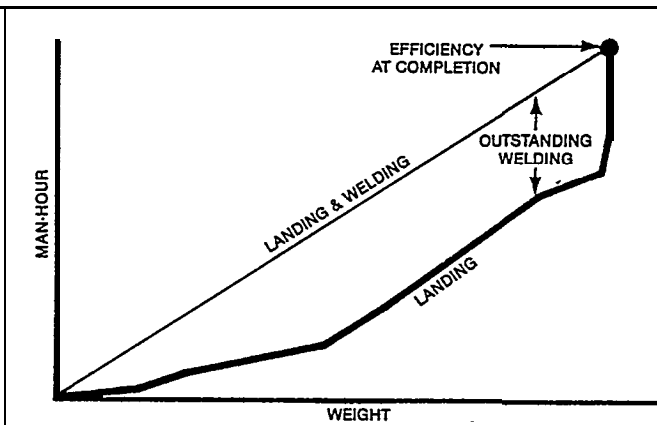


FIGURE 6-9: Productivity-Erection. In this special case the productivity index, man hours/fabricated weight, is used to establish a reference because weight accumulates rapidly as block are landed and welding man-hours lag. Managers employ the reference to monitor outstanding welding man-hours relative to landed weight.

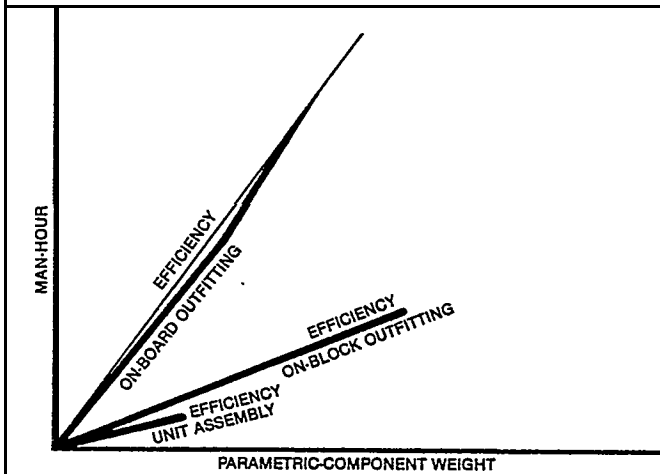


FIGURE 6-10: Productivity-Machinery Fitting. Parametric-component weight is the weight of only those items for which there are correlations between weight and fitting man-hours.

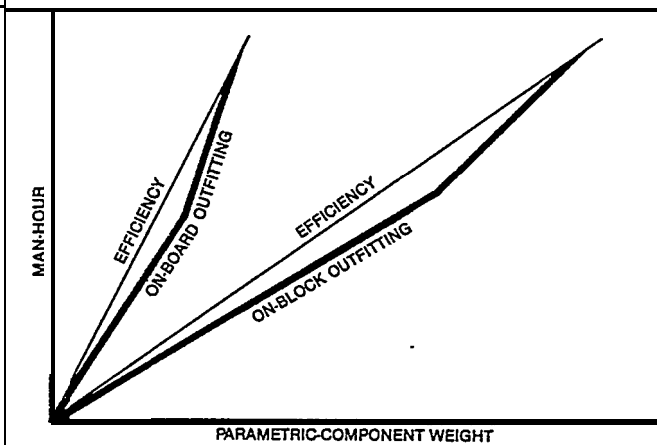


FIGURE 6-11: Productivity-Electrial Fitting of all components except cable. Each work package identifies total weight and parametric-component weight. The difference, i.e., items which comprise non-parametric-component weight, are treated as exceptions.

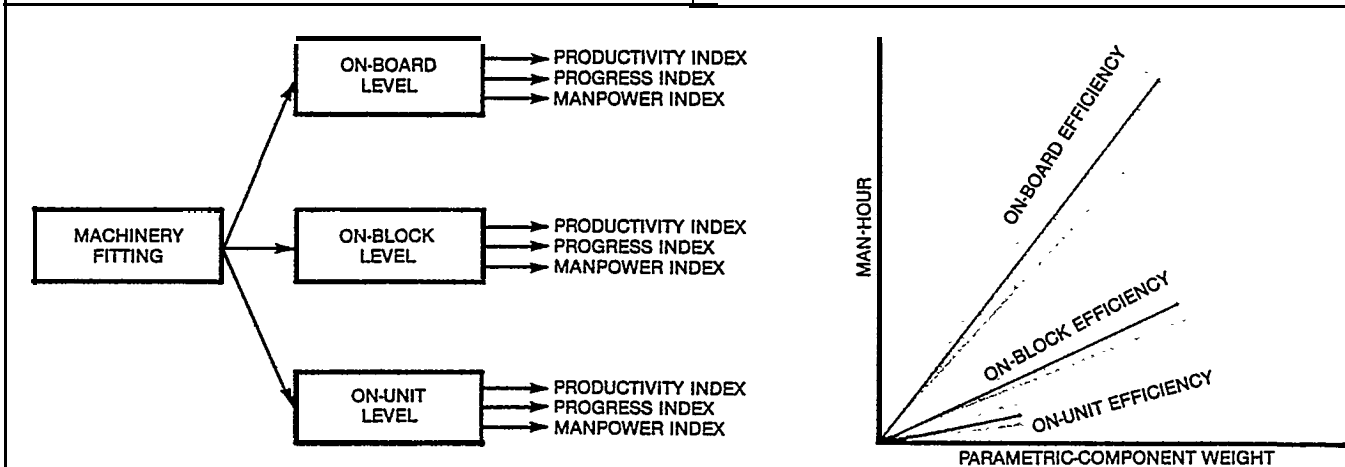


FIGURE 6-12: The Productivity-control Group (PCG) Concept as applied to Machinery Fitting. This example corresponds to a specific manpower-control group in Figure 5-3 (i.e., all elements of the Organization Code less trades). Regardless of product aspects, each work package efficiency rating falls within an allowable range specified for each manufacturing level. If normal performance causes overlap, such as is possible for on-unit and on-block efficiencies, there is no need to address them as separate PCG.

## 7.0 PRACTICAL SUGGESTIONS

PWBS facilitates the accumulation of experiences in a sequence of work packages which addresses specific interim products. Interim products for a subsequent ship-construction project, are matched to their predecessors by zone/area/stage in order to apply pertinent experiences regardless of differences in design details. Thus, a work package with a modest goal, e.g., a small assembly of outfit components, can be significantly improved in productivity value over just a few ship construction projects. This process of continuing improvement is dependent upon the reorientation of managers and workers and in particular upon the interaction of designers and field engineers. The following suggestions, by functions, are intended to assist in implementation of PWBS.

### 7.1 Sizing Work Packager

#### 7.1.1 Quality

As described in Part 1.3 herein, quality (Q) is a fundamental element for determining the productivity value (PV) and hence size of a work package. In addition to evaluating the impact of specified accuracy or functioning ability of an interim product, it also assesses the safety and efficiency of related work.

For HBCM work, Q evaluations should be made during transition design. Ideal division of a hull into blocks should result in:

- minimal welding during erection,
- stable blocks that facilitate erection,
- block and part shapes that, as much as possible, are standard within each hull and facilitate outfitting and painting.

Fulfillment of these objectives in planning results in the safest and most efficient work circumstances in production.

The Q for ZOFM work packages is considerably dependent upon hull structure. Therefore, extraordinary coordination is required during transition design so that outfit work specialists who establish the system/zone interrelationships on composites can:

- for zone considerations arrange components to facilitate the progress of outfit work zone-by-zone and group-by-group; gather and lay pipe pieces and electric cables in orderly pipe and cable passages respectively locate pipe line joints for connecting between blocks, on the same deck or flat;
- for area considerations group components in order to coordinate the start of work for machinery foundations, machinery, pipe supports, pipe pieces, walkways, etc.;
- for stage considerations phase components to reduce overhead work by fitting on-ceiling with blocks turned over and to reduce services required during on-open-space fitting of large components; and
- incorporate modularized work packages and work package components as much as possible.'

#### 7.1.2 Quantity

As described in Part 1.3 herein, quantity (N) is an indicator of the amount of all resources required for a work package. However, of the resources, material and manpower quantities are the principal N determinants.

The number of components for a work package should be limited to that which a worker can quickly sort and fit at a designated site. Otherwise, a disproportionate amount of the working time allocated is used to find needed components. Work packages which contain large components can be sized by weight.

---

"Improving Shipyard production with Standard Components and Modules" by Y. Ichinose, IHI CO., Ltd., Tokyo: proceedings of the SNAME Spring Meeting, April 26, 1978, pp. 10-1 to 10-11.

Manpower should be allocated by considering skill levels of workers and their assistants and the work volume involved. It is sometimes necessary to add manpower in order to reduce planned working time.

### 7.1.3 Time

As stated in Part 1.3 herein, time (T) is the duration allowed for accomplishment of a work package; it is working time. It is a key element for scheduling. Work packages, insofar as possible, should be organized for accomplishment within modularized time spans, e.g., within five or ten days. This facilitates scheduling of work package starts and completions *in unison* as is required for on-flow work. Durations achievable are dependent upon Q, N and workers' abilities and degrees of persistency.

## 7.2 Design and Material Definition

### 7.2.1 Hull Construction

- (1) Zone-oriented block plans and corresponding block parts lists should be prepared as intermediate plans for transforming from system-oriented functional plans (e.g., midship section, and shell expansion) to working drawings by zone/area/stage (i.e., cutting, subassembly and assembly drawings).
- (2) Hull block planning should be performed in cooperation with field engineers to facilitate outfitting and painting as well as hull construction.
- (3) Block and part coding should be made block-by-block to facilitate coordinated scheduling of work package start dates and collection and sorting of parts and subassemblies. That is, all cutting, subassembly and assembly plans should be sequenced to anticipate the block assembly master schedule. This measure is necessary to avoid producing parts and subassemblies too far in advance. Items which are produced early, generally identical parts or subassemblies, create need for more storage space and problems associated with retrieval, non-uniform lead times, deteriorating shop-primer, etc. Further, the inconsistent grouping detracts from clear understanding of the production process grouped by area and stage which is necessary for layout of smooth operating process lanes.
- (4) A block plan should apply to a group of adjacent blocks and should be organized as a compact booklet which includes necessary work instructions.
- (5) Assembly, subassembly and cutting working drawings should be prepared by zone/area/stage. These should reflect the work instructions written in the block plan.
- (6) During marking, if parts for a specific block or for blocks once or twice removed in a schedule do not occupy all of a plate, the cutting plan should devote the excess material to flat-bar for stock rather than to parts needed far in advance.

- (7) The drawing issue schedule should be established block-by-block and be in accordance with the block assembly master schedule.

### 7.2.2 Outfitting

- (1) Using diagrammatic, all material requirement should be defined by system to facilitate sorting an early identification of long-lead time, manufacturing order and short-lead time materials.
- (2) Zone-oriented drawings (composites) should be prepared as intermediate drawings for transposing from system-oriented diagrammatic to work instructions drawings. The composites need only show enough detail to establish the system and zone inter relationships.
- (3) The arrangements on composites should anticipate basic scheme for zone/area/stage, i.e., a pallet list for which there has been agreement between designer and production engineers in the field.
- (4) A composite drawing should apply to a group of adjacent zones and even overlapping zones provided the latter are planned for different stages.
- (5) Planning for outfit work packages, grouped by zone/area/stage, should be integrated with hull block planning.
- (6) Work instruction drawings should include details for all pipe lines excepting only short tubing lengths for instruments.
- (7) Codes for outfit work packages and components should incorporate zone-by-zone identifications in order to facilitate coordinated scheduling of work package start dates and collection and sorting of outfit components.
- (8) Each work package should be clearly identified by zone/area/stage on a work instruction drawing and provided with a specific material list of fittings. Such drawings developed from composites (often by tracing) should provide information, commensurate with workers' comprehension levels, such as:
  - when, relative to other interim products should specific interim product be assembled,
  - what components it is to be produced from,
  - how is it to be assembled, etc.

These instructions are important. They must be continuously updated based upon feedback from worker and field engineers to detail designers. They are meant for an organization to retain useful work experience rather than allowing experience to be just vested in individuals. Also, the instructions are needed to adequately control work flow on process lanes. Work packages classified by the work problems they impose



are matched to sets of solutions which include specific worker qualification classes. This avoids need to assign the same individuals who produced identical interim products in the past. The absence of this arbitrary restriction facilitates scheduling for process flow lanes so that they are more uniformly loaded and better coordinated with each other.

### 7.3 Material Procurement and Control

#### 7.3.1 Hull Material

- (1) Lists for raw materials should be prepared from rough cutting plans for hull structural parts based upon reference to functional plans. Thus, commitment and systematic deliveries for maintenance of a minimum supply in the shipyard can be arranged at a very early stage.
- (2) Lists for raw materials should be reprepared from detail cutting Plans based upon reference to the block plan. These lists should be used to control material issues.

#### 7.3.2 Outfit Material

- (1) Each component, except minor common items freely available in bins near work sites, should be coded by piece and work package. The coding is essential in order to identify:
  - when specific material requisition orders should be released,
  - when material should be delivered to work sites, and
  - what fittings must be collected to fulfill a work package material list (MLF).
- (2) Each component should be painted at least through the primer level (if required) and identified with its code number (painted or tagged) by its in-house or subcontractor manufacturer before it is sent to the shipyard's warehouse.
- (3) Fittings should not be issued separately to workers calling at the warehouse. They should only become available to workers in a collection of materials (pallet) delivered at a specified time and place for execution of a specific work package.
- (4) Starting as early as the beginning of basic design through completion of palletizing, lead times for fittings must be considered by everyone concerned with material definition, procurement, manufacturing warehousing and palletizing.

### 7.4 Producing

#### 7.4.1 Hull Construction

- (1) Field engineers should have contributed to hull block planning in order to insure that designers anticipated the capabilities and limits of available manpower and

facilities, and worker safety requirements. Such input should be based upon experience at work sites.

- (2) In accordance with the PWBS concept, work packages should be organized to achieve coordinated work flows on specific process lanes as illustrated in Figure 2-4.
- (3) Standards are required for accuracy control of the separate flow lanes in accordance with consistent criteria. This insures that the end products of different work stages will ultimately fit together easily because their dimensions are within allowed tolerances based on a common scheme. Thus, a system for accuracy control is essential for maintaining scheduled work flows.
- (4) In a process lane, both the safety and quality of work circumstances for a specific work stage should be frequently evaluated and always in the context of the work stages immediately before and after.
- (5) Systematic in-process material control and associated time are required between successive work processes for collecting, sorting and distributing interim products (especially small end products after fabrication and sub-block assembly processes).

#### 7.4.2 Outfitting

- (1) Outfit work package planning and classifications should be proposed by production field engineers to detail designers for incorporation on composites and work instruction drawings.
- (2) Work package planning should reflect a pallet list and the PWBS concept as typically portrayed in Figure 2-4. In other words each work package should address a zone by stage and be classified by similarities in work problems.
- (3) On-unit and on-block outfitting should be planned for accomplishment on sites adjacent to the erection site in order to avoid transportation problems immediately before erection.
- (4) The on-unit, on-block and on-board outfitting master schedules should reflect the block erection and block assembly master schedules. Careful coordination is required with other functions (e.g. design, material procurement, hull construction, painting) for such concerns as:
  - time reservations for necessary outfitting on-block before a block is completed,
  - needed lead times for design, material definition, procurement and fabrication.
- (5) Work instruction drawings grouped by zone/area/stage should be prepared for outfit workers' convenience even at some added expense in design.

- (6) Accuracy standards are required for the end products of outfit flow lanes consistent with those for hull construction and for the same reasons. Work instructions for the correction of probable misalignments should be included in order to minimize disruption to scheduled work flow when rework is necessary.
- (7) The fitting of each complicated arrangement should be in three distinct stages which may be termed "plan/do/see". That is at the:
- first stage, workers study the work instructions and discuss them with their supervisor,
  - second stage, work is performed, and at the
  - third stage, workers discuss with their supervisor, and when appropriate a field engineer, how similar future work packages could be improved.

