

Production and Muonic Decay of Heavy Quarks in e^+e^- Annihilation at 34.5 GeV

TASSO Collaboration

M. Althoff, W. Braunschweig, F.J. Kirschfink, K. Lübelmeyer, H.-U. Martyn, G. Peise, J. Rimkus, P. Rosskamp, H.G. Sander, D. Schmitz, H. Siebke, W. Wallraff

I. Physikalisches Institut der RWTH, D-5100 Aachen, Federal Republic of Germany^a

H.M. Fischer, H. Hartmann, W. Hillen¹, A. Jocksch, G. Knop, L. Köpke, H. Kolanoski, H. Kück, R. Wedemeyer, N. Wermes², M. Wollstadt³

Physikalisches Institut der Universität, D-5300 Bonn, Federal Republic of Germany^a

Y. Eisenberg⁴, K. Gather, H. Hultschig, P. Joos, W. Koch, U. Kötze, H. Kowalski, A. Ladage, B. Löhr, D. Lüke, P. Mättig, D. Notz, R.J. Nowak⁵, J. Pyrlík, D.R. Quarrie⁶, M. Rushton, W. Schütte, D. Trines, G. Wolf, Ch. Xiao

Deutsches Elektronen-Synchrotron, DESY, D-2000 Hamburg, Federal Republic of Germany

R. Fohrmann, E. Hilger, T. Kracht, H.L. Krasemann, P. Leu, E. Lohrmann, D. Pandoulas, G. Poelz, B.H. Wiik

II. Institut für Experimentalphysik der Universität, D-2000 Hamburg, Federal Republic of Germany^a

R. Beuselinck, D.M. Binnie, A.L. Campbell, P.J. Dornan, B. Foster, D.A. Garbutt, C. Jenkins, T.D. Jones, W.G. Jones, J. McCardle, J.K. Sedgbeer, W.A.T. Wan Abdullah

Department of Physics, Imperial College London SW7 2BZ, England^b

K.W. Bell, M.G. Bowler, P. Bull, R.J. Cashmore, P.E.L. Clarke, R. Devenish, P. Grossmann, C.M. Hawkes, S.L. Lloyd, G.L. Salmon, J. Thomas, T.R. Wyatt, C. Youngman

Department of Nuclear Physics, Oxford University, OX1 3RH, England^b

G.E. Forden, J.C. Hart, J. Harvey, D.K. Hasell, J. Proudfoot⁷, D.H. Saxon, P.L. Woodworth⁸

Rutherford Appleton Laboratory, Chilton, Didcot, Oxon OX11 0QX, England^b

F. Barreiro, M. Dittmar, M. Holder, B. Neumann

Fachbereich Physik der Universität-Gesamthochschule, D-5900 Siegen, Federal Republic of Germany^a

E. Duchovni, U. Karshon, G. Mikenberg, R. Mir, D. Revel, E. Ronat, A. Shapira, G. Yekutieli

Weizmann Institute, Rehovot, Israel^c

T. Barklow, A. Caldwell, M. Cherney, J.M. Izen, M. Mermikides, G. Rudolph, D. Strom, H. Venkataramania, E. Wicklund, Sau Lan Wu, G. Zoernig

Department of Physics, University of Wisconsin, Madison, WI 53706, USA^d

Received 24 November 1983

1 Now at Philips, Aachen, FRG

2 Now at SLAC, Stanford, CA, USA

3 Now at Lufthansa, Frankfurt, FRG

4 On leave from Weizmann Institute, Rehovot, Israel

5 On leave from Warsaw University, Poland

6 Now at FNAL, Batavia, IL, USA

7 Now at Argonne National Laboratory, Argonne, IL, USA

8 Now at Institute of Oceanographic Sciences, Bidston, Merseyside, UK

a Supported by the Deutsches Bundesministerium für Forschung und Technologie

b Supported by the UK Science and Engineering Research Council

c Supported by the Minerva Gesellschaft für Forschung mbH

d Supported by the US Department of Energy contract WY-76-C-02-0881

Abstract. The production of prompt muons in e^+e^- annihilation has been studied at centre of mass energies near 34.5 GeV. The measured semi-muonic branching ratios of b and c quarks are $B(b \rightarrow X\mu\nu) = 0.117 \pm 0.028 \pm 0.01$ and $B(c \rightarrow X\mu\nu) = 0.082 \pm 0.012^{+0.02}_{-0.01}$. The fragmentation functions of heavy quarks are hard, $\langle z_b \rangle = 0.85^{+0.10+0.02}_{-0.12-0.07}$ and $\langle z_c \rangle = 0.77^{+0.05+0.03}_{-0.07-0.11}$. Limits have been set on flavour changing neutral current decays: $B(b \rightarrow X\mu^+\mu^-) < 0.02$ and $B(c \rightarrow X\mu^+\mu^-) < 0.007$ (95% confidence level).

1. Introduction

The study of prompt electrons or muons produced in e^+e^- annihilation into hadronic final states provides important information on the properties of c and b quarks. Measurements at energies just above threshold for open charm or bottom production allow determination of the semi-leptonic branching ratios of the lowest lying states and of the lepton momentum spectra in their rest systems [1-3]. Measurement at energies well above threshold permits determination of the semi-leptonic branching ratios averaged over all states and also fragmentation functions of c and b quarks [4-7]. In addition, at energies above ~ 30 GeV the detection of electroweak interference effects through the observation of forward-backward asymmetries in lepton production becomes possible. In this paper we present the results of a study of prompt muon production at centre of mass energies W between 33.0 and 35.6 GeV (mean energy 34.5 GeV), using the TASSO detector at PETRA. The initial data sample consisted of 21553 accepted hadronic events, corresponding to an integrated luminosity of 75 pb^{-1} , which yielded 1136 muon candidates with momentum $> 1.5 \text{ GeV}/c$.

The TASSO detector consists of a cylindrical central detector of radius 1.35 m within a magnetic field of 5 kG. The return yoke for the magnetic field is an iron box with open sides, with a thickness of 80 cm of iron above and below the solenoid and 50 cm of iron capping the ends of the solenoid. Lead-liquid argon calorimeters are installed between the solenoid and the iron yoke. Muon detection chambers are installed 30 cm above and below the yoke iron in the horizontal plane, and in the vertical plane both above and below the beam pipe 70 cm from the end cap iron. The open sides of the yoke

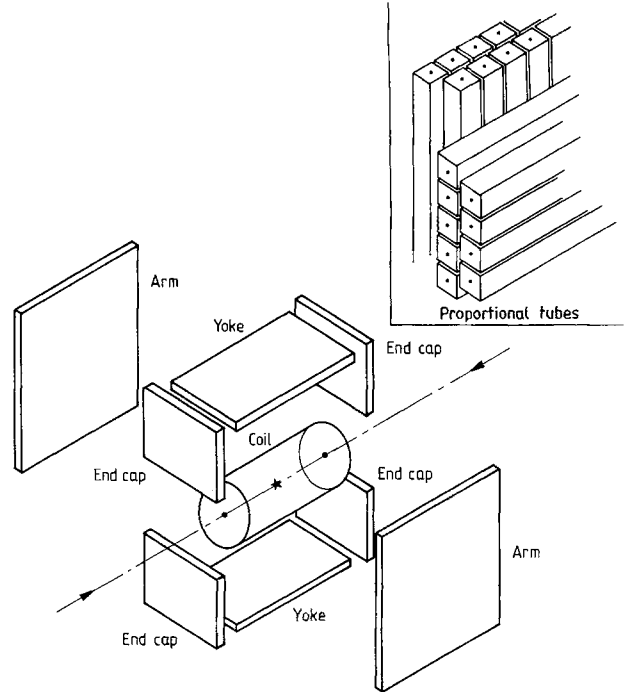

Fig. 1. Disposition of the muon detection chambers in TASSO. The insert shows the configuration of the four layers of proportional tubes

box give access to two transverse arms for hadron identification. At the far ends, 5.5 m from the interaction point, are lead-scintillator shower counters followed by iron 87 cm thick: 20 cm behind this iron are muon detection chambers. The layout of the muon detection chambers in the horizontal plane (Yoke) and vertical planes (Arms, End Caps) is shown schematically in Fig. 1. In this study of prompt muon production, information from only the central detector and the muon detection chambers has been used once an event has been accepted.

A general description of the TASSO apparatus has been given in [8, 9] and the procedure for extracting hadronic events has been given in [10]. A detailed description of the cylindrical drift chamber may be found in [11]. The precision of the central detector is important in this experiment; the cylindrical drift chamber has a momentum resolution $\sigma_p/p = 0.016\sqrt{1+p^2}$ where p is the momentum transverse to the magnetic field in units of GeV/c.

The muon detection chambers were assembled from $4 \text{ cm} \times 4 \text{ cm}$ rectangular aluminium proportional tubes. Each chamber consisted of four layers of tubes with two layers offset by 2 cm in each of two orthogonal directions, forming a double gridiron pattern. The structure is shown as an insert in Fig. 1. A general description of the muon chambers is given in [9] and a detailed description may be

found in [12]. The Yoke chambers covered a solid angle of $0.17 \times 4\pi$, the Arm chambers $0.13 \times 4\pi$ and the End Cap chambers $0.13 \times 4\pi$ steradians.

2. Selection of Muon Candidates

The first criterion for a muon candidate was that either four wires in a muon chamber fired, two adjacent in each direction, or three out of a possible four. The efficiency of wires in a single layer was determined from the ratio of hits with three wires to hits with four, and exceeded 90% in all chambers. The detection efficiency when requiring either three or four wires firing exceeded 95%. The minimum muon momentum required to penetrate the Yoke or Arm iron absorber is 1.2 GeV/c: in every hadronic event with one or more accepted hits in the muon chambers, each charged track with a momentum > 1.2 GeV/c was extrapolated to the planes of the muon chambers. An error ellipse was calculated for each extrapolated track, including the contributions of tracking errors in the central detector and multiple scattering in the magnet coil, the shower counters and the iron absorber. For each track, an area corresponding to ten standard deviations about the extrapolation point was searched for an accepted hit in the muon chambers. In the event of a hit being within 10σ of more than one extrapolated track, the hit was assigned to the more probable track (assuming, in every case, the track to be a muon). This procedure leads to some misassociation of tracks with hits, but allowance was made for this in the subsequent analysis.

Those associations with a muon confidence level $> 1\%$ (the hit lying within the contour expected to contain 99% of true muons) were accepted as good muon candidates. Those with confidence level $< 1\%$ are almost entirely background and will be referred to as bad candidates: they were used to constrain the background. Our sample of 21553 accepted hadronic events yielded 1136 good muon candidates and 889 bad candidates with momenta greater than 1.5 GeV/c. Monte Carlo studies showed that only 3% of good muon candidates and less than 1% of prompt muons are misassociated.

3. Sources of Background

The prompt muon signal due to semi-leptonic decay of particles carrying c and b quarks is diluted by muons from π and K mesons decaying within the central detector (which will be referred to as internal decays), by muons from decays occurring outside the

central detector (external decays) and by charged hadrons penetrating without interaction to the muon chambers or generating secondary hadrons which penetrate to the muon chambers (punch through). Each of these three sources of background contributes $\geq 20\%$ of the good muon candidates while prompt muons from c decay contribute $\sim 25\%$ and from b decay $\sim 10\%$. The Yoke, Arm and End Cap detectors have very different susceptibility to these different sources of background and their relative contribution is also highly momentum dependent (see Table 1).

The branching ratios and fragmentation functions of b and c quarks were extracted from the data by comparison with Monte Carlo events. The LUND generator [13] was used, with radiative corrections applied, to produce pairs of u , d , s , c , b quarks and gluons at the parton level, with subsequent hadronisation. The parameters of the generator had been chosen so as to reproduce well the principal features of the hadronic data. All generated particles were followed through the central detector and allowed to interact or scatter in the detector material and to decay within the central detector. The generated hadronic events were subjected to the same analysis programs as the data.

External decays and punch through were handled differently. We used the Monte Carlo program GHEISHA [14] to calculate for both pions and kaons the probability of penetration of the coil, counters and iron absorber by decay muons or secondary hadrons at the mean angle of incidence for each of the Yoke, Arm and End Cap detectors. The distance in the plane of the muon chambers from the extrapolated hadron was also determined. Both the probability and the radial distribution of tracks in the plane of the muon chambers were parametrised as a function of hadron type and momentum, for Yoke, Arms and End Caps [15].

Any generated hadron pointing at the iron absorber was accordingly allocated a penetration probability through either external decay or punch through, and the penetrating particle was assigned coordinates in the plane of the muon chamber. The punch through probability was corrected for the effects of extra material traversed at angles of incidence other than the mean with an exponential in the difference of the number of absorption lengths presented. (Separate studies of the penetration of hadrons incident at several angles showed that this procedure was adequate).

In the final stage of Monte Carlo generation [16], all tracks emerging from the iron absorber, regardless of origin, fired individual proportional tubes in accord with the efficiencies already deter-

Table 1. The table shows the number of good muon candidates and bad candidates, for Yoke, Arm and End Cap detectors, in each of the nine regions of the $p_L - p_T$ (GeV/c) grid fitted. Also shown are the predictions for punchthrough (PTHRU), decays external to the central detector (EXT), decays internal to the central detector (INT), $c \rightarrow X\mu\nu$ (CMU), $b \rightarrow c \rightarrow X\mu\nu$ (BCMU), $b \rightarrow X\mu\nu$ (BMU). The background numbers are the original (unfitted) predictions, the prompt muon contributions are for the heavy quark branching ratios and mean z values given as the final results (Sect. 6)

	Good muon candidates											
	$P_T < 0.6$				$0.6 < P_T < 1.2$				$1.2 < P_T$			
	$P_L < 2$				$P_L < 2$				$P_L < 2$			
	A	Y	C	Total	A	Y	C	Total	A	Y	C	Total
PTHRU	4.87	11.05	24.34	40.26	2.01	3.66	10.60	16.27	0.91	1.75	7.24	9.9
EXT	26.52	7.06	8.84	42.42	17.75	4.98	6.31	29.04	7.74	2.69	3.46	13.89
INT	11.50	24.07	21.32	56.89	5.24	12.30	11.38	28.92	2.47	5.93	6.59	14.99
CMU	9.08	15.14	8.73	32.95	4.47	8.29	5.24	18.0	1.32	2.37	2.46	6.15
BCMU	1.15	2.03	1.05	4.23	0.92	1.23	0.73	2.88	0.34	0.31	0.28	0.93
BMU	0.81	0.92	0.50	2.23	3.30	5.29	2.77	11.36	3.44	6.30	4.44	14.18
TOTAL	53.93	60.26	64.78	178.97	33.68	35.75	37.03	106.46	16.21	19.35	24.46	60.02
DATA	48.00	43.00	66.00	157	37.00	22.00	30.00	89	11.00	9.00	23.00	43
CHISQ	0.63	4.80	0.02		0.32	5.13	1.29		1.62	5.32	0.08	
	$P_T < 0.6$				$0.6 < P_T < 1.2$				$1.2 < P_T$			
	$2 < P_L < 4$				$2 < P_L < 4$				$2 < P_L < 4$			
	A	Y	C	Total	A	Y	C	Total	A	Y	C	Total
	PTHRU	12.79	16.00	30.53	59.32	7.83	7.24	17.48	32.55	2.85	2.67	7.58
EXT	29.15	9.97	10.77	49.89	21.07	7.16	6.62	34.85	5.40	2.56	3.06	11.04
INT	11.72	22.24	20.69	54.65	5.93	11.90	10.10	27.93	1.90	3.37	3.40	8.67
CMU	20.70	34.56	21.39	76.65	10.44	15.11	9.74	35.29	2.25	3.42	2.65	8.32
BCMU	1.41	2.19	1.16	4.76	0.93	1.44	0.96	3.33	0.27	0.77	0.36	1.4
BMU	2.22	2.71	1.49	6.42	6.12	10.37	4.46	20.95	6.21	9.93	5.44	21.58
TOTAL	78.00	87.67	86.04	251.71	52.33	53.22	49.37	154.92	18.88	22.71	22.48	64.07
DATA	93.00	82.00	96.00	271	51.00	53.00	60.00	164	23.00	27.00	23.00	73
CHISQ	2.59	0.35	1.11		0.03	0.00	2.22		0.87	0.79	0.01	
	$P_T < 0.6$				$0.6 < P_T < 1.2$				$1.2 < P_T$			
	$P_L > 4$				$P_L > 4$				$P_L > 4$			
	A	Y	C	Total	A	Y	C	Total	A	Y	C	Total
	PTHRU	11.56	10.38	16.33	38.27	11.26	9.47	17.58	38.31	5.84	4.98	10.77
EXT	8.81	5.23	4.27	18.31	6.82	4.58	5.17	16.57	3.42	2.12	2.39	7.93
INT	2.96	4.26	4.18	11.4	2.48	4.29	3.73	10.5	1.49	3.19	2.77	7.45
CMU	14.31	19.94	14.64	48.89	10.78	13.02	9.43	33.23	2.79	4.76	3.64	11.19
BCMU	0.11	0.47	0.20	0.78	0.34	0.31	0.20	0.85	0.20	0.39	0.17	0.76
BMU	3.45	5.10	3.57	12.12	7.68	10.71	7.15	25.54	8.78	12.20	8.26	29.24
TOTAL	41.20	45.38	43.18	129.76	39.35	42.37	43.26	124.98	22.51	27.64	28.00	78.15
DATA	45.00	46.00	41.00	132	39.00	44.00	44.00	127	21.00	24.00	34.00	79
CHISQ	0.34	0.01	0.11		0.00	0.06	0.01		0.10	0.46	1.24	

Good muon candidates $\chi^2 = 29.7/23$ degrees of freedom

mined from the data. Muon chamber hits were then associated with tracks in the central detector, using the same programs as were used with the data.

4. Analysis and Results

Because the minimum momentum needed to penetrate the Yoke and Arm absorber is 1.2 GeV/c and

the size of the error ellipse decreases rapidly with increasing momentum, the analysis was restricted to hits having associated tracks with momentum > 1.5 GeV/c.

Preliminary studies indicated a branching ratio for $b \rightarrow X\mu\nu \sim 0.12$ and for $c \rightarrow X\mu\nu \sim 0.09$, with hard fragmentation functions $\langle z_b \rangle \gtrsim 0.85$, $\langle z_c \rangle \gtrsim 0.60$, where z_b , z_c for a hadron carrying a b or c quark is given by the sum of the hadron energy (E) and the

Table 1 (continued)

Bad candidate hits												
$P_T < 0.6$				$0.6 < P_T < 1.2$				$1.2 < P_T$				
$P_L < 2$				$P_L < 2$				$P_L < 2$				
	A	Y	C	Total	A	Y	C	Total	A	Y	C	Total
P1THRU	12.92	27.96	72.03	112.92	2.81	7.63	23.64	34.08	0.88	2.38	14.62	17.88
EXT	5.26	2.72	4.18	11.23	3.69	2.21	2.99	8.89	2.60	1.32	2.09	6.01
INT	2.18	2.45	4.29	8.92	1.03	1.63	3.25	5.91	0.50	1.18	2.55	4.23
PROMPT	0.39	0.84	1.05	2.28	0.21	0.66	0.81	1.68	0.18	0.33	0.57	1.08
TOTAL	20.75	33.97	81.55	135.34	7.74	12.13	30.69	50.56	4.16	5.21	19.83	29.2
DATA	33.00	35.00	104.00	172	14.00	16.00	27.00	57	7.00	4.00	22.00	33
CHISQ	7.23	0.03	5.99		4.91	1.20	0.43		1.88	0.27	0.23	

$P_T < 0.6$				$0.6 < P_T < 1.2$				$1.2 < P_T$				
$2 < P_L < 4$				$2 < P_L < 4$				$2 < P_L < 4$				
	A	Y	C	Total	A	Y	C	Total	A	Y	C	Total
P1THRU	18.00	32.75	97.80	148.55	9.21	15.24	50.50	74.95	3.40	4.65	21.22	29.27
EXT	20.31	7.04	10.10	37.45	15.24	5.67	6.01	26.92	4.45	2.17	2.89	9.51
INT	2.91	4.78	5.22	12.91	1.68	3.11	4.00	8.79	1.08	1.97	2.39	5.44
PROMPT	1.20	1.02	1.83	4.05	0.66	0.63	1.53	2.82	0.42	0.21	0.66	1.29
TOTAL	42.42	45.59	114.95	202.96	26.79	24.65	62.04	113.48	9.35	9.00	27.16	45.51
DATA	57.00	34.00	129.00	220	31.00	23.00	48.00	102	7.00	11.00	16.00	34
CHISQ	4.86	2.86	1.66		0.64	0.11	3.08		0.57	0.43	4.45	

$P_T < 0.6$				$0.6 < P_T < 1.2$				$1.2 < P_T$				
$P_L > 4$				$P_L > 4$				$P_L > 4$				
	A	Y	C	Total	A	Y	C	Total	A	Y	C	Total
P1THRU	21.27	20.18	50.17	91.62	18.68	18.70	50.80	88.18	10.84	9.29	31.35	51.48
EXT	10.90	3.20	4.17	18.27	9.94	3.14	4.71	17.79	4.65	2.05	2.71	9.41
INT	0.90	1.21	1.89	4.0	1.63	2.48	2.33	6.44	2.43	3.51	4.94	10.88
PROMPT	0.42	0.18	0.75	1.35	0.12	0.21	0.90	1.23	0.27	0.12	0.78	1.17
TOTAL	33.49	24.77	56.98	115.24	30.37	24.53	58.74	113.64	18.19	14.97	39.78	72.94
DATA	36.00	19.00	45.00	100	38.00	20.00	47.00	105	26.00	14.00	26.00	66
CHISQ	0.18	1.30	2.44		1.86	0.81	2.28		3.25	0.06	4.63	

Bad candidates $\chi^2 = 57.6/27$ degrees of freedom (unfitted)

component of momentum in the original direction of the heavy quark (p_{\parallel}), divided by the sum of the initial energy and momentum of the heavy quark (E_Q, p_Q):

$$z = \frac{E + p_{\parallel}}{E_Q + p_Q}$$

The prompt muon spectra in the laboratory are not sensitive to the detailed shape of the heavy quark fragmentation functions $f(z)$, and so we adopted the convenient one parameter form of [17]:

$$f(z) \propto \frac{1}{z[1 - (1/z) - \epsilon/(1-z)]^2}$$

We generated seven Monte Carlo samples of $\sim 100,000$ accepted hadronic events such that

$$\langle z_b \rangle = 0.8; \quad \langle z_c \rangle = 0.45, 0.55, 0.65, 0.75$$

$$\langle z_b \rangle = 0.6, 0.7, 0.9; \quad \langle z_c \rangle = 0.55$$

and the generated prompt muon momentum spectra in the centre of mass of B and D mesons were in agreement with the results from CLEO [2] and DELCO [18] respectively*.

* The cms momentum spectra of muons from decay of c and b baryons have not been measured. For plausible rates of baryon production, our results would not be affected significantly by reasonable variations in the shapes of these spectra

Both the data and the generated muon candidates were divided into 9 momentum regions defined by the limits

$$p_T < 0.6 \text{ GeV}/c, 0.6 < p_T < 1.2 \text{ GeV}/c, 1.2 \text{ GeV}/c < p_T \\ p_L < 2.0 \text{ GeV}/c, 2.0 < p_L < 4.0 \text{ GeV}/c, 4.0 \text{ GeV}/c < p_L$$

where p_T is the transverse momentum of the track associated with a muon hit and p_L the longitudinal momentum, relative to the thrust axis of the event. The three categories of background exhibited no significant variation with either $\langle z_b \rangle$ or $\langle z_c \rangle$; the contribution of muons from c decay following b decay is everywhere small and showed no significant variation with $\langle z_b \rangle$. The variation of the contribution of muons from b decay with $\langle z_b \rangle$ and from decay of primary c quarks with $\langle z_c \rangle$ was precisely determined with a quick Monte Carlo without simu-

lation of the detector, generating 10^5 muonic decays for eight values of both $\langle z_b \rangle$ and $\langle z_c \rangle$. These variations were parametrised as either a flat, linear or quadratic function of $\langle z \rangle$, and normalised to the results obtained from the Monte Carlo samples which included simulation of the detector.

A fit was then performed to the good muon candidates in the four variables: branching ratio for $b \rightarrow X \mu \nu$, $\langle z_b \rangle$, branching ratio for $c \rightarrow X \mu \nu$ and $\langle z_c \rangle$. The Monte Carlo results for both good muon candidates and bad candidates are compared with the data in Table 1 for the best fit, which yielded results

$$B(b \rightarrow X \mu \nu) = 0.117 \pm 0.028$$

$$\langle z_b \rangle = 0.85 \begin{array}{l} +0.10 \\ -0.12 \end{array}$$

$$B(c \rightarrow X \mu \nu) = 0.082 \pm 0.012$$

$$\langle z_c \rangle = 0.77 \begin{array}{l} +0.05 \\ -0.07 \end{array}$$

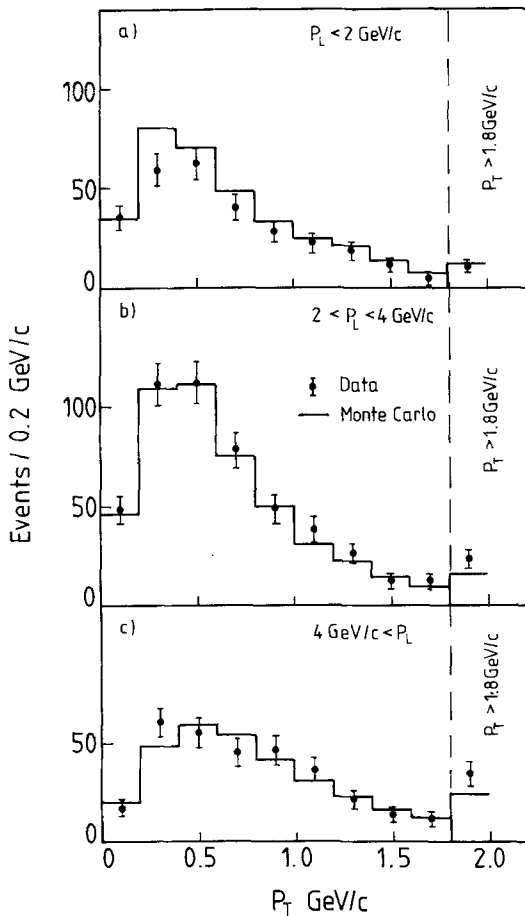

Fig. 2a-c. p_T distribution of good muon candidates. **a** $p_L < 2 \text{ GeV}/c$, **b** $2 < p_L < 4 \text{ GeV}/c$, **c** $4 \text{ GeV}/c < p_L$. The points with error bars are the data; the histograms Monte Carlo results using the original (unfitted) estimates of background and the final results (Sect. 6) for b and c branching ratios and fragmentation functions. The last bin in each case contains hits with $p_T > 1.8 \text{ GeV}/c$

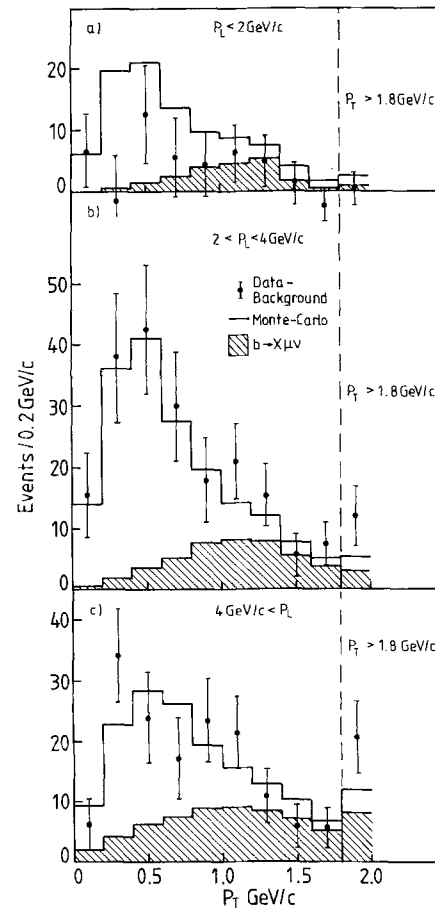

Fig. 3a-c. p_T distribution of good muon candidates after subtraction of the estimated background. The histogram shows the fitted prompt muon spectrum and the contribution of $b \rightarrow X \mu \nu$ is shown separately. The last bin in each case contains results for $p_T > 1.8 \text{ GeV}/c$

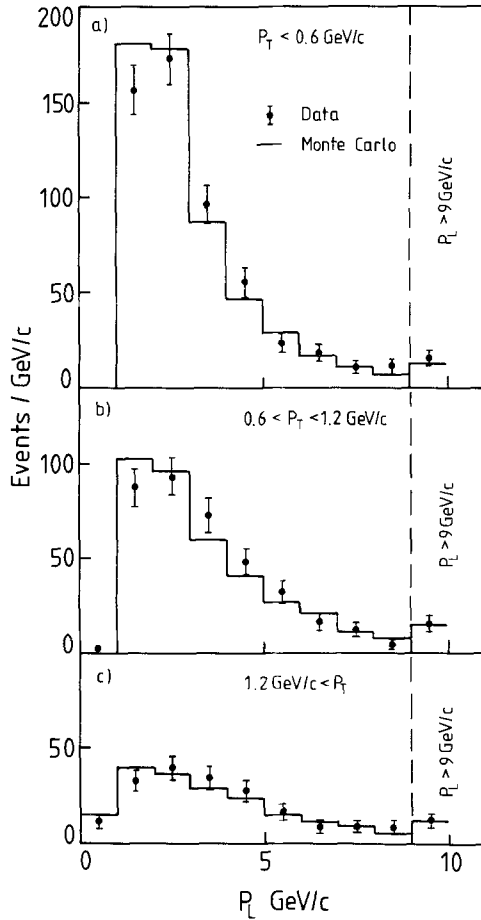

Fig. 4a-c. p_L distribution of good muon candidates. **a** $p_T < 0.6$ GeV/c, **b** $0.6 < p_T < 1.2$ GeV/c, **c** 1.2 GeV/c $< p_T$. The points with error bars are the data; the histograms Monte Carlo results using the original (unfitted) estimates of background and the final results (Sect. 6) for b and c branching ratios and fragmentation functions. The last bin in each case contains hits with $p_L > 9$ GeV/c

where the errors are purely statistical and include both the effects of correlations and the (small) contribution of Monte Carlo statistical errors. We note that the properties of hadrons carrying b quarks are determined primarily through the data with $p_T > 1.2$ GeV/c and those of hadrons carrying c quarks through the data with $p_T < 0.6$ GeV/c. The fit to the good muon candidates yielded $\chi^2 = 29.5/23$ degrees of freedom (χ^2 confidence level 0.18). The bad candidates are contributed primarily by the tails of the radial distributions from internal decay, external decay and punch through, and are more susceptible to error resulting from misassociation. Testing the predicted bad candidates against the data yielded $\chi^2 = 57.6/27$ degrees of freedom. There is no indication of any systematic error in the comparison of the bad candidate data with the calculated background.

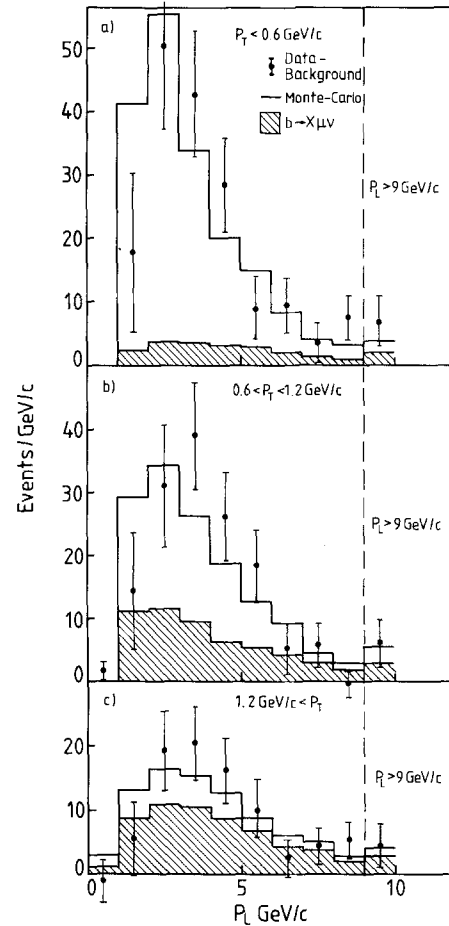

Fig. 5a-c. p_L distribution of good muon candidates after subtraction of the estimated background. The histogram shows the fitted prompt muon spectrum and the contribution of $b \rightarrow X \mu \nu$ is shown separately. The last bin in each case contains results for $p_L > 9$ GeV/c

The data and Monte Carlo calculations are compared as functions of p_T, p_L in Figs. 2-5.

5. Systematic Errors

We checked that the generated charged particle multiplicity and momentum spectrum are in excellent agreement with the data, and that the prompt muon momentum spectra in the B and D meson rest frames are in agreement with CLEO and DELCO results respectively [2, 18]. The external decay background generated by GHEISHA was checked against an independent Monte Carlo program.

Both the absolute punch through rates and the radial distribution of punch through hadrons as predicted by GHEISHA are in fair agreement with such

meagre data as exist at relatively low momentum [15]. We have nonetheless carried out an extensive study of the effects of selecting subsamples of the data and of varying the backgrounds, using the bad candidate data as a constraint.

Since the background is expected to be most uncertain at low momentum, we made four parameter fits to the good muon candidates omitting data with $p_L < 2$ GeV/c and $p_T < 0.6$ GeV/c, < 1.2 GeV/c, and all p_T . We also fitted the good muon candidates in the Yoke, Arm and End Cap detectors separately, and in each pair of detectors.

We included the bad candidates in the fit and allowed the various components of the background to float in absolute magnitude. We also kept the total punch through, external decay and internal decay constant (good muon candidates + bad candidates), while changing the relative proportions of good muon candidate and bad candidate hits. Most of these studies in which the background was fitted were made with nine extra parameters, (Yoke, Arms, Caps; internal decays, external decays, punch through) where the permitted variations in the three longitudinal momentum regions were related. A number of different relations were tested: the best of these fits was obtained when the background contributions were allowed to change in magnitude, the predicted number of good and bad muon candidates in the i^{th} category of background and the j^{th} detector being allowed to vary by factors $(1 + 3x_{ij})$, $(1 + 2x_{ij})$, $(1 + x_{ij})$ for $0 < p_L \leq 2$ GeV/c, $2 < p_L \leq 4$ GeV/c, $4 < p_L$ respectively, where the nine quantities x_{ij} are the additional parameters in the fit. The fit yielded $\chi^2 = 49.8/41$ degrees of freedom (χ^2 confidence level = 0.16, good muon candidates $\chi^2 = 12.3$, bad candidates $\chi^2 = 37.5$) and the results

$$\begin{aligned} B(b \rightarrow X \mu \nu) &= 0.123 \pm 0.028 \\ \langle z_b \rangle &= 0.82 \pm 0.11 \\ B(c \rightarrow X \mu \nu) &= 0.106 \pm 0.018 \\ \langle z_c \rangle &= 0.70 \pm 0.07. \end{aligned}$$

A fit with similar confidence level was also obtained by making a thirty one parameter fit, in which the variation of the three components of background for Yoke, Arm, Caps and for the three regions of p_L were unrelated. This fit yielded $\chi^2 = 30.1/23$ degrees of freedom (χ^2 confidence level = 0.16, good muon candidates $\chi^2 = 9.9$, bad candidates $\chi^2 = 20.3$) and the results

$$\begin{aligned} B(b \rightarrow X \mu \nu) &= 0.106 \begin{matrix} +0.035 \\ -0.028 \end{matrix} \\ \langle z_b \rangle &= 0.85 \pm 0.15 \end{aligned}$$

$$\begin{aligned} B(c \rightarrow X \mu \nu) &= 0.078 \begin{matrix} +0.032 \\ -0.02 \end{matrix} \\ \langle z_c \rangle &= 0.79 \begin{matrix} +0.08 \\ -0.14 \end{matrix} \end{aligned}$$

The four parameters of interest remained extremely stable regardless of the recipe employed. In particular, we checked explicitly that our hard fragmentation functions are not spurious by allowing the background variation to increase with p_L . The origin of this stability can be appreciated from inspection of Table 1: the contribution of different sources of hits to different regions of the $p_T - p_L$ grid and to Yoke, Arms and Caps varies to such an extent that the background and prompt muon components are tightly constrained by the 54 separate data bins fitted, despite permitting individual background components to fall as low as zero or grow to twice the originally calculated value.

6. Final Results for Heavy Quark Branching Ratios and Fragmentation Functions

Since we have no evidence that our original background estimates are significantly in error, we give as our final results the answers obtained fitting to the good muon candidates alone, with the original estimate of background contributions

$$\begin{aligned} B(b \rightarrow X \mu \nu) &= 0.117 \pm 0.028 \text{ (statistical)} \pm 0.01 \text{ (systematic)} \\ \langle z_b \rangle &= 0.85 \begin{matrix} +0.10 \\ -0.12 \end{matrix} \text{ (statistical)} \begin{matrix} +0.02 \\ -0.07 \end{matrix} \text{ (systematic)} \\ B(c \rightarrow X \mu \nu) &= 0.082 \pm 0.012 \text{ (statistical)} \begin{matrix} +0.02 \\ -0.01 \end{matrix} \text{ (systematic)} \\ \langle z_c \rangle &= 0.77 \begin{matrix} +0.05 \\ -0.07 \end{matrix} \text{ (statistical)} \begin{matrix} +0.03 \\ -0.11 \end{matrix} \text{ (systematic)} \end{aligned}$$

The systematic errors reflect the spread of results obtained as described in Sect. 5: our systematic errors are relatively small due primarily to the use of the bad candidates to constrain the background.

The mean values of z_b , z_c and their errors correspond to the following values of the parameter ε [17]:

$$\begin{aligned} \varepsilon_b &= 0.0025 \begin{matrix} -0.0025 & -0.0013 \\ +0.029 & +0.011 \end{matrix} \\ \varepsilon_c &= 0.006 \begin{matrix} -0.005 & -0.003 \\ +0.017 & +0.052 \end{matrix} \end{aligned}$$

and to

$$\begin{aligned} \langle x_b \rangle &= 0.81 & +0.04 & +0.02 \\ & & -0.09 & -0.05 \\ \langle x_c \rangle &= 0.71 & +0.05 & +0.04 \\ & & -0.07 & -0.11 \end{aligned}$$

where $x = E_{\text{hadron}}/E_{\text{beam}}$.

The results are compared in Table 2 with other measurements of these parameters, for heavy quark decay into muons and into electrons. Our results are in very good agreement with these other measurements, except that they are hardly compatible with the result $\langle z_c \rangle = 0.46 \pm 0.02 \pm 0.05$ from [6].

Our results are certainly compatible with measurements of the D^* and D^0 fragmentation functions [19, 20, 26, 27], where the results are given in terms of the variable x (the energy of the charmed hadron divided by the beam energy). Values of the quantity $\langle x_c \rangle$ obtained from fitting these data in x with the form of [17] are given in Table 2. We find

that our result for $\langle z_c \rangle$ corresponds to $\langle x_c \rangle = 0.71^{+0.05+0.04}_{-0.07-0.11}$, which is entirely compatible with the direct measurements. Measurement of the D^* fragmentation properties with the TASSO detector [20] yielded $\langle x_{D^*} \rangle = 0.58 \pm 0.04$, corresponding to $\langle z_{D^*} \rangle = 0.65^{+0.06}_{-0.05}$. A three parameter fit to the good muon candidate hits with $\langle z_c \rangle$ fixed at 0.65 yielded $\chi^2 = 33/24$ degrees of freedom (χ^2 confidence level = 0.11) and

$$B(b \rightarrow X \mu \nu) = 0.141 \pm 0.026 \text{ (statistical)}$$

$$\langle z_b \rangle = 0.90 \pm 0.09 \text{ (statistical)}$$

$$B(c \rightarrow X \mu \nu) = 0.078 \pm 0.012 \text{ (statistical)}.$$

Hard fragmentation functions for heavy quarks have been predicted on a variety of theoretical grounds [17, 21–24] and the relation $\langle z_Q \rangle \sim 1 - \frac{k}{m_Q}$ is expect-

Table 2. Results on semileptonic branching ratios and fragmentation functions of heavy quarks

Exp.	Ref.	W GeV	Muons			
			$B(b \rightarrow X \mu \nu)$	$\langle z_b \rangle$	$B(c \rightarrow X \mu \nu)$	$\langle z_c \rangle$
CLEO	[2]	10.55	$0.122 \pm 0.017 \pm 0.031$	-	-	-
MAC	[5]	29	$0.155^{+0.054}_{-0.029}$	0.8 ± 0.1	-	$0.17 - 0.67$
MARK-J	[6]	33–38	$0.105 \pm 0.015 \pm 0.013$	$0.75 \pm 0.03 \pm 0.06$	$0.115 \pm 0.01 \pm 0.017$	$0.46 \pm 0.02 \pm 0.05$
CELLO	[7]	14, 22, 34	$0.088 \pm 0.034 \pm 0.03$	-	$0.123 \pm 0.029 \pm 0.039$	-
TASSO	This work	34.5	$0.117 \pm 0.028 \pm 0.01$	$0.85^{+0.10+0.02}_{-0.12-0.07}$	$0.082 \pm 0.012^{+0.02}_{-0.01}$	$0.77^{+0.05+0.03}_{-0.07-0.11}$
Electrons						
			$B(b \rightarrow X e \nu)$	$\langle z_b \rangle$	$B(c \rightarrow X e \nu)$	$\langle z_c \rangle$
review	[1]	3.77–7.4	-	-	0.078 ± 0.014 0.08 ± 0.02 0.072 ± 0.02 0.082 ± 0.019	-
CLEO	[2]	10.55	$0.127 \pm 0.017 \pm 0.013$	-	-	-
CUSB	[3]	10.55	$0.132 \pm 0.008 \pm 0.014$	-	-	-
MARK II	[4]	29	$0.116 \pm 0.021 \pm 0.017$	$0.75 \pm 0.05 \pm 0.04$	$0.063 \pm 0.012 \pm 0.021$	-
CELLO	[7]	14, 22, 34	$0.141 \pm 0.058 \pm 0.03$	-	-	-
D^*						
						$\langle x_c \rangle$
MARK II	[19]	29				0.58 ± 0.06
TASSO	[20]	34.5				0.58 ± 0.04
HRS	[26]	29				0.51 ± 0.04
CLEO	[27]	10.5				0.63 ± 0.02

The values of $\langle x_c \rangle$ have been obtained from the results of fits to the function of [17] in terms of the variable x_c .

ed to obtain. Taking $m_c=1.8$ GeV, $m_b=5$ GeV and fitting the parameter k we obtained a good fit ($\chi^2=30/24$ degrees of freedom, χ^2 confidence level =0.17) with

$$k=0.44 \pm 0.12 \text{ (statistical)} \begin{matrix} +0.15 \\ -0.05 \end{matrix} \text{ (systematic)}$$

corresponding to

$$\langle z_b \rangle = 0.91 \begin{matrix} -0.025 & -0.03 \\ +0.025 & +0.01 \end{matrix}$$

$$\langle z_c \rangle = 0.755 \begin{matrix} -0.07 & -0.08 \\ +0.07 & +0.03 \end{matrix}$$

The branching ratios extracted for the heavy quarks agree very well with other measurements and the hard fragmentation functions inferred are in good agreement with other measurements and with theoretical expectations. Thus our measurements of prompt muon production at 34.5 GeV are in agreement with the assumption that the only sources are particles carrying c and b quarks. The results summarised in Table 2 are in good agreement with $e-\mu$ universality in the weak interactions of both b and c quarks.

7. Multiple Muon Production

Our sample contains one event with three good muon candidates and forty three events with two good muon candidates with $p > 1.5$ GeV/c. The results shown in Table 3 are in accord with the assumption that the only sources of prompt muons are $b \rightarrow X \mu \nu$, $c \rightarrow X \mu \nu$, but only 12 events containing two good candidates both due to prompt muons are expected, the remainder consisting of events with one prompt muon and one background hit and events with two background hits.

The data with two hits in the same jet, associated with oppositely charged particles, may be used to set limits on the flavour changing neutral current processes $b \rightarrow X \mu^+ \mu^-$, $c \rightarrow X \mu^+ \mu^-$. There are 13 events in this category, whereas 11 are expected assuming

Table 3. Disposition of events containing two good muon candidates with momentum > 1.5 GeV/c. Monte Carlo results are shown in parentheses

Same jet		Opposite jets	
opposite charges	same charges	opposite charges	same charges
13 (11)	9 (5)	16 (17)	5 (10)

no production of $\mu^+ \mu^-$ pairs. The number of events which could represent heavy quark decay into muon pairs is thus 2 ± 3.3 , less than 8.6 at the 95% confidence limit. The Monte Carlo reproduces the single hit results with such accuracy that these errors are dominated by statistics.

The limit of 8.6 events corresponds to $B(b \rightarrow X \mu^+ \mu^-) < 0.02$ and $B(c \rightarrow X \mu^+ \mu^-) < 0.007$, assuming muon spectra in the heavy quark centres of mass similar to the single muon spectra in the charged current processes. More stringent limits on $B(b \rightarrow X \mu^+ \mu^-)$ have already been reported [28].

8. Electroweak Effects

The forward backward asymmetry of events containing a good muon candidate with $p > 1.5$ GeV/c, $p_T > 1.2$ GeV/c has been measured. We find 89 cases where the jet containing a μ^+ goes forward (in the direction of the positron beam) or the jet containing a μ^- goes backwards, and 106 cases where the jet containing a μ^+ goes backwards or a μ^- jet goes forwards. The measured forward-backward asymmetry is thus

$$A_{\text{measured}} = -8.7 \pm 7.1 \%$$

This number must be corrected for geometrical acceptance, background due to punchthrough and decay, and the contribution of $c \rightarrow X \mu \nu$, assumed to have a true asymmetry of +14%. The measured asymmetry then corresponds to a true asymmetry for particles carrying a b quark, over the full solid angle, of

$$A = -37.5 \pm 27.5 \%$$

to be compared with

$$A^{\text{GWS}} = -27 \%$$

expected for b quarks in the standard model. Other measurements of the b quark asymmetry have been reported in [7, 29].

9. Conclusions

The production of prompt muons has been studied in $e^+ e^-$ annihilation at a mean energy of 34.5 GeV. The results are in agreement with the assumption that the only sources of prompt muons are the semi-leptonic decays of b and c quarks, and we obtain branching ratios

$$B(b \rightarrow X \mu \nu) = 0.117 \pm 0.028 \pm 0.01$$

$$B(c \rightarrow X \mu \nu) = 0.082 \pm 0.012 \begin{matrix} +0.02 \\ -0.01 \end{matrix}$$

The fragmentation functions of heavy quarks are hard,

$$\langle z_b \rangle = 0.85 \begin{matrix} +0.10 & +0.02 \\ -0.12 & -0.07 \end{matrix}$$

$$\langle z_c \rangle = 0.77 \begin{matrix} +0.05 & +0.03 \\ -0.07 & -0.11 \end{matrix}$$

The latter result is consistent with direct measurements of the fragmentation functions of D^* and D^0 mesons.

Hadrons containing a b quark are produced with a forward-backward asymmetry of

$$A = -37.5 \pm 27.5 \%$$

to be compared with the value

$$A^{\text{GWS}} = -27 \%$$

expected within the standard model.

We have set limits on possible flavour changing neutral current decays of b and c quarks:

$$B(b \rightarrow X \mu^+ \mu^-) < 0.02$$

$$B(c \rightarrow X \mu^+ \mu^-) < 0.007$$

at the 95% confidence limit.

Acknowledgements. We are indebted to H. Fesefeldt for supplying us with his Monte Carlo program GHEISHA and for a number of useful discussions. We are grateful to R.K. Carnegie for his important contributions to the early stages of this work. We gratefully acknowledge the support of the DESY directorate and the PETRA machine group. We wish to thank the technical service groups at DESY and all the engineers and technicians at the collaborating institutes for their valuable help. Those of us from outside DESY wish to thank the DESY directorate for the hospitality extended to us while working at DESY.

References

1. G.H. Trilling: Phys. Rep. **75 C**, 57 (1981) (review)
2. CLEO Collab. K. Chadwick et al.: Phys. Rev. **D 27**, 475 (1983)
3. CUSB Collab. C. Klopstein et al.: Phys. Lett. **130 B**, 444 (1983)
4. MARK II Collab. M.E. Nelson et al.: Phys. Rev. Lett. **50**, 1542 (1983)
5. MAC Collab. E. Fernandez et al.: Phys. Rev. Lett. **50**, 2054 (1983)
6. MARK-J Collab. B. Adeva et al.: Phys. Rev. Lett. **51**, 443 (1983)
7. CELLO Collab. H.J. Behrend et al.: Z. Phys. C - Particles and Fields **19**, 291 (1983)
8. TASSO Collab. R. Brandelik et al.: Phys. Lett. **83 B**, 261 (1979)
9. TASSO Collab. R. Brandelik et al.: Phys. Lett. **92 B**, 199 (1980)
10. TASSO Collab. R. Brandelik et al.: Phys. Lett. **113 B**, 499 (1982)
11. H. Boerner et al.: Nucl. Instrum. Methods **176**, 151 (1980)
12. M. Ogg, D. Phil: Thesis Oxford 1981; RHEL Report RL-HEP-T-89
13. B. Andersson, G. Gustafson, T. Sjöstrand: Phys. Lett. **94 B**, 211 (1980); T. Sjöstrand: Lund preprints LU TP 82-3, 82-7 (1982); Comput. Phys. Commun. **27**, 243 (1982); **28**, 229 (1983)
14. H. Fesefeldt: Aachen PITHA report, in preparation
15. P. Grossmann: Oxford University Report OUNP 74/83
16. J. Thomas: D. Phil. Thesis Oxford (1983)
17. C. Peterson et al.: Phys. Rev. **D 27**, 105 (1983)
18. DELCO Collab. W. Bacino et al.: Phys. Rev. Lett. **43**, 1073 (1979)
19. MARK II Collab. J.M. Yelton et al.: Phys. Rev. Lett. **49**, 430 (1982)
20. TASSO Collab. M. Althoff et al.: Phys. Lett. **126 B**, 493 (1983)
21. J.D. Bjorken: Phys. Rev. **D 17**, 171 (1978)
22. M. Suzuki: Phys. Lett. **71 B**, 139 (1977)
23. M.G. Bowler: Z. Phys. C - Particles and Fields **11**, 169 (1981)
24. J. Oliensis: Phys. Rev. **D 23**, 1430 (1981)
25. JADE Collab. W. Bartel et al.: Phys. Lett. **114 B**, 71 (1982)
26. HRS Collab. S. Ahlen et al.: Phys. Rev. Lett. **51**, 1147 (1983)
27. CLEO Collab. P. Avery et al.: Phys. Rev. Lett. **51**, 1139 (1983)
28. JADE Collab. W. Bartel et al.: DESY 83-049 (1983) and ref. [15] therein; MARK-J collab. B. Adeva et al.: Phys. Rev. Lett. **50**, 799 (1983); See also S. Stone: Talk delivered at Int. Symp. on Lepton and Photon Interactions at High Energy, Cornell 1983
29. B. Naroska: Talk delivered at Int. Symp. on Lepton and Photon Interactions at High Energy, Cornell 1983