



City Research Online

City, University of London Institutional Repository

Citation: Qian, K., Liang, S., Fu, F. & Li, Y. (2021). Progressive Collapse Resistance of Emulative Precast Concrete Frames with Various Reinforcing Details. *Journal of Structural Engineering*, 147(8), 04021107.. doi: 10.1061/(ASCE)ST.1943-541X.0003065

This is the accepted version of the paper.

This version of the publication may differ from the final published version.

Permanent repository link: <https://openaccess.city.ac.uk/id/eprint/25755/>

Link to published version: [https://doi.org/10.1061/\(ASCE\)ST.1943-541X.0003065](https://doi.org/10.1061/(ASCE)ST.1943-541X.0003065)

Copyright: City Research Online aims to make research outputs of City, University of London available to a wider audience. Copyright and Moral Rights remain with the author(s) and/or copyright holders. URLs from City Research Online may be freely distributed and linked to.

Reuse: Copies of full items can be used for personal research or study, educational, or not-for-profit purposes without prior permission or charge. Provided that the authors, title and full bibliographic details are credited, a hyperlink and/or URL is given for the original metadata page and the content is not changed in any way.

City Research Online:

<http://openaccess.city.ac.uk/>

publications@city.ac.uk

25 530004 (corresponding author), qiankai@gxu.edu.cn

26 ²Research Student, College of Civil Engineering and Architecture at Guangxi University, Nanning, China
27 530004, liangshilin@st.gxu.edu.cn

28 ³Senior Lecturer ⁴(Associate Professor) in Structural Engineering, School of Mathematics, Computer
29 Science and Engineering, City, University of London, U.K., Feng.Fu.1@city.ac.uk

30 ⁴Associate Professor, Key Laboratory of Urban Security and Disaster Engineering of Ministry of Education,
31 Beijing University of Technology, Beijing 1000124, China, yili@bjut.edu.au

32 INTRODUCTION

33 Progressive collapse is defined as the spread of an initial local failure from element to element,
34 which eventually results in the collapse of an entire structure or a disproportionately large part of
35 it (ASCE SEI7 2010). The collapse of Alfred P. Murrah Federal Building, Oklahoma City, 1995
36 and twin towers in World Trade Center, New York, 2001 have all demonstrated the disastrous
37 consequences of progressive collapse. To minimize the potential of such disaster, alternate load
38 path (ALP) method, which is one of direct design methods from DoD (2010) and GSA (2013), is
39 commonly utilized for practical design and analysis due to its threat-independent feature. In ALP
40 method, various column removal scenarios are analyzed to assess the load redistribution capacity
41 of the remaining building to bridge the initial damage (Stevens et al 2011; Fu,2016).

42 Based on ALP method, extensive tests (Sasani 2008; Sasani and Kropelnicki 2008; Yi et al.
43 2008; Sadek et al. 2011; Qian et al.2020; Qian and Li 2012a, b; Yu et al. 2013; Lew et al. 2014;
44 Qian et al. 2015; Valipour et al. 2015; Shan et al. 2016; Lu et al. 2017; Lin et al. 2019; Yu et al.
45 2020; Deng et al. 2020) had been carried out. Sasani (2008) and Sasani and Kropelnicki (2008)
46 carried out pioneer in-situ tests to quantify the dynamic behavior of RC frames subjected to
47 column removal explosively. However, as the column longitudinal reinforcement was not clearly
48 removed in the tests, the measured dynamic response in these in-situ tests was not obvious and
49 only elastic response was captured. In addition, these in-situ dynamic tests indicated that upper
50 stories worked together to redistribute the load, caused by the removed columns. Therefore,
51 several dynamic tests (Qian and Li 2012b; Yu et al. 2014; Qian and Li 2017) relied on single-story

52 beam-column sub-assemblages were carried out to study the behavior of prototype multi-story
53 frames equivalently. These dynamic tests indicated that the internal force may be amplified due to
54 dynamic effects (Qian and Li 2012b). However, the dynamic effects will not change the failure
55 mode and mobilization of load resisting mechanisms (Qian et al. 2020). Therefore, majority of
56 existing tests regarding progressive collapse were single-story beam-column sub-assemblages
57 subjected to quasi-static loading regime (Orton et al. 2008; Su et al. 2009; Qian and Li 2013; Yu
58 et al. 2013; Qian et al. 2016; Ren et al. 2016; Yu et al. 2020; Deng et al. 2020). Although extensive
59 tests were carried out to investigate the load resisting mechanism of RC frames subjected to
60 different column missing scenarios, tests on precast concrete (PC) frames against progressive
61 collapse were rare. Kang and Tan (2015; 2017) investigated performance of PC beam-column sub-
62 assemblages with emulative connections subjected to column removal scenarios. Qian and Li
63 (2018; 2019) experimentally quantified the load resisting mechanism of PC beam-column sub-
64 structures with dry connections to resist progressive collapse. The effects of PC slabs were
65 incorporated in Qian and Li (2018). It should be noted that the load resisting mechanisms of PC
66 frames against progressive collapse varies in different types of beam-column connections. Thus,
67 more studies are needed for deeper understanding of the progressive collapse resistance of PC
68 frames with different beam-column connections or reinforcing details. For this reason, in this paper,
69 three emulative PC beam-column sub-assemblages with different reinforcement details in beam-
70 column connections were tested to quantify the effects of connection details on load resisting
71 mechanisms of emulative PC frames. One additional RC beam-column sub-assemblages were also
72 tested just as a reference test.

73 **EXPERIMENTAL PROGRAM**

74 **Frame Design**

75 The prototype building used in the tests was a nine-story moment resisting frame, which was
76 non-seismically designed in accordance with ACI 318-14 (2014) and PCI handbook (PCI 2010).
77 The design live load (LL) and dead load (DL) were 2.0 kPa and 5.5 kPa, respectively. Similar to
78 the tests of Yu and Tan (2013), in this study, a series of beam-column sub-assemblages, composed
79 of two beams, two enlarged side columns, and one middle column stub, were extracted from the
80 prototype building for test. They were one-half scaled due to spacing and capacity limitation of
81 the lab. Three PC frames (IA, SA, and UB) and one RC frame (RC) were designed and tested. As
82 shown in Table 1, the notation “IA” denoted PC frame with Insufficient Anchorage for beam
83 bottom reinforcements in the connection. “SA” represented PC frame with Sufficient Anchorage
84 for beam bottom reinforcements in the connection. “UB” indicated PC frame with additional U-
85 shaped bars passing through the middle joint, while the beam bottom reinforcements were bent up
86 90° and terminated at the beam end. In the fabrication of PC frames, the process can be divided
87 into following steps. Firstly, the precast units (hatched area in Fig. 1) were casted. Then, the
88 horizontal interfaces were grinded 4 mm deep intentionally to enhance the bond between precast
89 elements and cast-in-situ toppings. After assembling PC columns and beams, additional U-shaped
90 bars were added passing through the joints continually for UB. Finally, 50 mm depth topping layer
91 and remaining part of the joints were casted on site.

92 For RC, as shown in Fig. 1(a), the bottom reinforcements in beam were continuous with
93 curtailment. Moreover, the curtailment of longitudinal of bottom rebar followed the prototype
94 frame design. The beam cross section was 250 mm×150 mm with shear link of R6@100
95 throughout the whole span. As shown in Fig. 1(b), the beam bottom reinforcements of IA were

96 straight lap-spliced with an anchorage length of 230 mm, which was less than the required length
97 of 365 mm in accordance with ACI 318-14 (2014) and thus, the anchorage strength for the bottom
98 reinforcements was insufficient. This frame was designed to study the influence of insufficient
99 anchorage strength on the progressive collapse behavior of PC frames. For comparison, as shown
100 in Fig. 1(c), the bottom reinforcements of SA were bent up 90° and protruded into joint to achieve
101 sufficient anchorage strength. As shown in Fig. 1(d), UB has U-shaped trough with length of 370
102 mm in each beam end, its bottom reinforcements in PC beams were bent up 90° and terminated at
103 beam ends. To continuously connect the PC components, two U-shaped bottom bars were added
104 passing through the middle joints.

105 **Material Properties**

106 The material properties of reinforcement are tabulated in Table 2. Based on cylinder tests, the
107 concrete compressive strength of RC frame on test day was 32 MPa. For PC frames, the first
108 batch concrete used for precast units had a compressive strength of 36 MPa while the second
109 batch concrete for cast-in-situ topping was 47 MPa, as required by PCI (2010).

110 **Test Setup and Instrumentation**

111 Fig. 2 illustrates the test setup and instrumentation layout. The side column was pin supported
112 and connected to an A-frame by two rollers installed horizontally. To release redundant horizontal
113 constraint from the pin support, a series of steel rollers [Item 8 in Fig. 2(b)] were placed beneath
114 the pin support. The middle column was removed notionally before test to simulate the initial
115 damage. Displacement-controlled loading method was applied on top of the missing column
116 location through a hydraulic jack [Item 2 in Fig. 2(b)]. To prevent out-of-plane failure, the frame
117 was restrained by a steel assembly [Item 3 in Fig. 2(b)] installed beneath the hydraulic jack [Item
118 2 in Fig. 2(b)]. A load cell [Item 1 in Fig. 2(b)] above the hydraulic jack was employed to measure

119 the applied load. Meanwhile, a load cell [Item 7 in Fig. 2(b)] was installed below each pin support
120 to measure the vertical reactions. To record horizontal reactions at the side column,
121 tension/compression load cell [Item 4 in Fig. 2(b)] was installed in each horizontal roller. A series
122 of linear variable displacement transducers (LVDTs) [Item 5 in Fig. 2(b)] were installed along the
123 beam to measure its deformation shape. Four LVDTs [Item 6 in Fig. 2(b)] were also installed along
124 the side columns to determine the stiffness of horizontal constraints. Moreover, strain gauges were
125 attached along reinforcements before casting.

126 **TEST RESULTS**

127 In this study, a series of half-scaled beam-column sub-assemblages were tested to investigate
128 the load resisting mechanisms of emulative PC frames against progressive collapse. Critical results
129 are tabulated in Table 3 whereas detailed results are discussed in below.

130 **Load Resistance and Failure Mode**

131 ***RC***

132 Fig. 3 gives the vertical load-displacement curve of test frames. For RC, the yield of beam
133 rebar was first observed at bottom beam rebar close to the middle column. The yield load (YL),
134 which was defined as the load when the beam longitudinal reinforcement yielding was first
135 measured, was 37 kN corresponding to a middle joint displacement (MJD) of 36 mm. When the
136 MJD reached 90 mm, the first peak load (FPL) of 52 kN was measured. The FPL was also called
137 as CAA capacity because the FPL was attributed into the enhanced flexural capacity due to
138 mobilization of CAA. Subsequently, the load resistance of the frame began to drop due to concrete
139 crushing. When the MJD exceeded 280 mm, the vertical load began to re-ascend because of
140 commencement of TCA. Penetrated cracks were observed when the MJD beyond this loading
141 stage. The penetrated cracks were uniformly distributed along the beam length with further

142 increasing MJD, which indicated tensile axial force developed in the beam. When the MJD
143 reached 410 mm, one of bottom rebars at beam-middle column interface fractured, causing sudden
144 drop of load resistance. The failure of the frame with complete loss of its load resistance occurred
145 at a MJD of 712 mm. The ultimate load (UL, which was defined as the maximum resistance of the
146 frame) or TCA capacity of this frame was 94 kN. The failure mode of RC is shown in Fig. 4. All
147 longitudinal reinforcement at one beam end nearby the middle column was fractured and severe
148 concrete crushing and spalling were observed there.

149 **IA**

150 PC frame IA had similar dimensions and rebar ratio as RC. However, the anchorage length
151 of the bottom rebar in IA was only 230 mm, which was less than the requirement of ACI 318-14
152 (2014). The YL and FPL of IA were 38 kN and 42 kN, respectively. The FPL of IA was only 81%
153 of that of RC, because the bottom reinforcements were pulled out from middle column, which
154 prevented further strain hardening. However, the pull-out of bottom reinforcements did not prevent
155 the mobilization of TCA and thus, the UL of IA was 98 kN, which was about 104% of that of RC.
156 This could be explained as the pull-out of bottom reinforcements close to the middle column
157 prevents the fracture of these reinforcements but the residual bond between concrete and
158 reinforcements allowed further development of tensile force in these bottom reinforcements at
159 TCA stage. Therefore, it was expected that the UL of IA could have been further increased if the
160 hydraulic jack had greater stroke capacity. However, the measured UL was still used for
161 comparison purpose herein. The failure mode of IA is shown in Fig. 5. It could be found that the
162 beam bottom reinforcements anchored into the middle column were pulled out and no rebar was
163 fractured. Moreover, different to RC, obvious horizontal cracks were formed at the interfaces
164 between PC units and cast-in-situ topping layer.

165 **SA**

166 For SA, the beam bottom reinforcements were bent up to 90° and anchored into the joints.
167 The YL and FPL of SA were 38 kN and 51 kN, respectively, which were very close to that of RC.
168 When the MJD reached 390 mm and 446 mm, beam bottom reinforcements near the middle
169 column fractured in sequence. At a MJD of 660 mm, the UL of 81 kN was measured. Subsequently,
170 top reinforcements of left beam near to the middle column fractured, as a result, SA lost its load
171 resistance suddenly. The UL of SA was approximately 86% of that of RC. This may due to the
172 higher bond stress caused by higher concrete strength in cast-in-situ topping layer casted on site,
173 which led to earlier fracture of the beam top longitudinal reinforcements. The failure mode of SA
174 is shown in Fig. 6. It was found that both top and bottom longitudinal reinforcements near the
175 middle column fractured completely. Moreover, horizontal cracks were also observed between PC
176 units and cast-in-situ topping layer.

177 **UB**

178 UB had U-shaped bars trough with length of 370 mm at the beam ends. Beam bottom
179 reinforcements were bent up 90° and did not pass through or be anchored into the column.
180 Additional U-shaped bars passed through the middle column to assemble the PC beams and
181 columns. The first yield of the beam reinforcements was noticed in the additional U-shaped bars
182 near the beam-middle column interfaces. The YL and FPL of UB were 38 kN and 48 kN,
183 respectively. Rebar fracture first occurred at the U-shaped bar near to the middle column at a MJD
184 of 341 mm. The UL of 75 kN, which was only 80% of that of RC, was measured at a MJD of 651
185 mm, which was only 91% of that of RC. As mentioned above, the lower UL could be explained
186 as the higher concrete strength in topping layer resulted in higher bond stress and earlier fracture
187 of beam top longitudinal reinforcements. The failure mode of UB is shown in Fig. 7, similar to

188 aforementioned PC frames, horizontal cracks and concrete crushing were observed at beam ends.
189 Moreover, it was found that plastic hinge was formed at the edge of the trough.

190 **Horizontal Reaction Force**

191 Fig. 8 shows horizontal reaction force-displacement curve of test frames. Negative and
192 positive values represented compressive and tensile reaction force, respectively. As shown in the
193 figure, compressive reaction force was measured first and indirectly demonstrated the
194 mobilization of CAA. The maximum horizontal compressive forces (MHCF) were -178 kN, -158
195 kN, -176 kN, and -169 kN for RC, IA, SA, and UB, respectively. Therefore, compared to RC
196 frame, PC frame with insufficient anchorage developed less CAA capacity. However, PC frame
197 with sufficient anchorage or additional U-shaped bar in connection zone could develop similar
198 CAA capacity as RC frame. At MJD of 354 mm, 303 mm, 308 mm, and 300 mm, compressive
199 reaction force transferred to tensile. The maximum horizontal tensile forces (MHTF) of RC, IA,
200 SA, and UB were 154 kN, 172 kN, 162 kN, and 138 kN, respectively. Therefore, PC frame with
201 insufficient anchorage could even develop greater TCA capacity than the RC counterpart, which
202 agreed with the vertical load-displacement behavior well.

203 **Deflection of the Double-Span Beam**

204 Fig. 9 shows the beam deflection of UB in various stages. The beam of UB was deformed in
205 a double-curvature manner from the beginning of the test. The beam shown symmetrical profile
206 until the first rebar fracture at a displacement of 341 mm. After that, asymmetry deflection of the
207 beam became evident. After beam bottom rebar close to the middle column fractured, the rotation
208 of the beam concentrated there. It could be found that the measured rotation of the beam ends near
209 the middle column was similar to the chord rotation, which was defined as the ratio of MJD to the
210 clear beam span in DoD (2010). However, the rotation of the beam ends near to the side column

211 was less than the chord rotation.

212 **Strain Gauge Reading**

213 Fig. 10 shows the strain profile of the beam longitudinal rebar in SA. As shown in the figure,
214 the beam bottom rebar near the middle column yielded first, whereas the beam top rebar near the
215 side column yielded subsequently. This was because the flexural capacity of the joints in the
216 middle column was lower than that of side column, while they experienced similar bending
217 moment demands. At compressive zones, all compressive rebar strains declined when the CAA
218 became exhausted and then tensile strains were observed for all measurement points due to
219 development of the TCA. Similar observations were measured in RC. Fig. 11 gives the rebar strain
220 variation measured in IA. Similar to SA, the rebar near the side column yielded latter than the one
221 near the middle column. Moreover, the strain in B12 dropped suddenly at a MJD of 122 mm,
222 indicating pulling-out failure of the beam bottom rebar. However, tensile strain of about 1200 $\mu\epsilon$
223 was observed after the rebar pulling-out in the subsequent loading history. This could be attributed
224 to the residual bond between the pulling-out rebar and concrete. Fig. 12 shows the strain variation
225 in beam longitudinal rebar and U-shaped rebar of UB. It could be found that the first yield of the
226 rebar occurred in the U-shaped rebar near the middle column since the beam bottom longitudinal
227 rebars were bent up 90° and terminated at the beam ends. In general, the development of strain of
228 the beam top rebar was similar to SA.

229 **DISCUSSION OF TEST RESULTS**

230 **Effects of Reinforcing Details**

231 As shown in Fig. 3 and Table 3, the FPL of RC, IA, SA, and UB were 52 kN, 42 kN, 51 kN,
232 and 48 kN, respectively. Therefore, the CAA capacity of IA achieved only 81% of that of RC
233 because beam bottom reinforcements near to the middle column were pulled out. However, the

234 CAA capacity of SA and UB was approximately 98% and 92% of RC and thus, PC frame with
 235 sufficient anchorage or additional U-shaped bar connection could develop similar CAA capacity
 236 as RC frame. The UL of RC, IA, SA, and UB were 94 kN, 98 kN, 81 kN, and 75 kN, respectively.
 237 It was found that IA could attain the highest UL although pulling-out failure occurred at the beam
 238 end near to the middle column. This was because the pull-out of bottom reinforcements prevented
 239 the fracture of these rebar, while the residual bond between these pulling-out rebar and concrete
 240 could still increase the horizontal tensile reaction force at TCA stage. As mentioned previously,
 241 the relatively lower UL of SA and UB was mainly due to the higher bond stress between beam top
 242 rebar and cast-in-situ topping layer, which led to the earlier rebar fracture and lower deformation
 243 capacity.

244 **Load Resistance De-Composition**

245 As shown in Fig. 13, force analysis was carried out to de-composite the contribution of load
 246 resistance. It can be seen that the load resistance P equals to the summation of vertical projections
 247 of the shear force (V) and axial force (N) at the critical sections.

$$248 \quad P = (N \sin \theta + V \cos \theta) \quad (1)$$

249 where θ is the local rotation of the beam segment near to the middle column and it can be
 250 determined by the measured displacements of D_3 and D_4 ($\theta = \arctan\left(\frac{4(D_4 - D_3)}{L}\right)$); D_3 is the
 251 vertical displacement at the position with $L/4$ away from the middle column whereas D_4 is the
 252 MJD; L is beam clear span.

253 The shear force (V) and axial force (N) can be determined by Eqs. 2 and 3:

$$254 \quad N = (V_L \tan \theta + H_t + H_b) \cos \theta \quad (2)$$

$$255 \quad V = (V_L - N_s i \theta) / \theta \quad (3)$$

256 The bending moment at the beam end near to the middle column (M_M) and the one near to
 257 the side column (M_S) can be determined by Eqs. 4 and 5:

$$258 \quad M_M = V_L l - H_t (D_4 + 0.35) - H_b (D_4 - 0.35) \quad (4)$$

$$259 \quad M_S = 0.2 V_L - 0.3 H_t + 0 E \quad (5)$$

260 where H_t and H_b are the horizontal reaction forces at the top and bottom roller, respectively;
 261 V_L is the vertical reaction force measured at the pin support; l is distance from the center of the
 262 left side column to the critical section.

263 The de-composition of the load resistance of IA, SA, and UB are given in Fig. 14. It can be
 264 seen that, at small deformation stage, the shear force provided majority of the load resistance. With
 265 the increase of MJD, the contribution of shear force decreased because of evanishment of the
 266 flexural action due to concrete crushing, while the load resistance from the axial force transferred
 267 from negative to positive because the beginning of TCA. At large deformation stage, the tensile
 268 axial force dominated the load resistance and the contribution from shear force kept decreasing.
 269 However, based on this analysis, it was incorrect to conclude that at large deformation stage, the
 270 load resistance purely attributed into TCA.

271 The variation of bending moments at the beam ends are shown in Fig. 15. The overall trend
 272 of the bending moment was similar to that of load resistance from the shear force. As mentioned
 273 above, the contribution of the shear force actually reflected the load resisting contribution of
 274 flexural action. As shown in Fig. 15, due to pulling-out failure of the beam bottom reinforcements,
 275 the maximum bending moment of IA at the beam end near to the middle column was much lower
 276 than that of SA and UB.

277 **Tie Force**

278 The ultimate chord rotation which was defined as the ultimate displacement to the beam clear span
279 of RC, IA, SA, and UB were 0.24, 0.23, 0.24, and 0.22, respectively. As tested results had indicated
280 that 0.20 radian rotational capacity requirement of DoD (2010) could be satisfied for tested RC
281 and PC frames, the tie-force requirements of DoD (2010) were evaluated herein. The required tie-
282 force can be determined by Eq. 6.

283
$$Fp = 6W_F L_1 L_p \quad (6)$$

284 where W_F is the floor load (7.6 kN/m² as a result of load combination of (1.2DL + 0.5LL));
285 L_1 is the distance between column centers; L_p is the allowed floor width (0.91 m in DoD (2010)
286 and 0.46 m herein as 1/2 scaled frames).

287 The required tie forces were listed in Table 3. It was found that the measured tie-forces (UL
288 herein) were greater than the required tie-forces for all frames. Therefore, PC beams with
289 emulative connections could provide sufficient tie-force to resist progressive collapse.

290 **Proposal New TCA Model and Evaluation of Existing CAA Models for PC Frames**

291 To facilitate practical applications of TCA, a simplified model was proposed herein to predict the
292 TCA capacity. Based on the test results, it was found that the UL was mainly controlled by the top
293 reinforcements as the bottom reinforcements fracture earlier and therefore, only tensile forces in
294 the top reinforcements were considered in the proposed model. As illustrated in Fig. 16, the angle
295 θ of the tensile forces can be determined by the points of resultant forces in the beam end sections.
296 Thus, the proposed model can be expressed as follows

297
$$P_{TCA} = 2f_u A_{st} \sin \theta \quad (7)$$

298 where f_u and A_{st} are the ultimate strength and area of the top reinforcement at the section
299 near to the middle column, respectively.

300 The calculated results from the proposed model were compared with the test results in Fig.
301 3. The calculated results agreed with the test results well although slightly under-estimation was
302 obtained. Actually, for safety's sake, conservative result is preferred for design.

303 Compared to TCA, CAA raises much lower demand in continuity of rebar and deformation
304 capacity. Therefore, it is preferred to prevent progressive collapse relying on CAA. Yu and Tan
305 (2014) and Lu et al. (2018) proposed analytical models to assess the CAA capacity. For the models,
306 please refer to corresponding paper due to spacing limitation. The reliability of these models for
307 evaluation of CAA capacity of PC frames was quantified herein. As shown in Fig. 17a, both
308 models may overestimate the CAA capacity of IA due to pulling-out failure of the bottom
309 reinforcements near to the middle column. As shown in Figs. 17(b-d), both analytical models
310 predicted the CAA capacity of remaining specimens reasonably. However, as Yu and Tan (2014)'s
311 model relied on iteration, for simplicity, Lu et al. (2018)'s model was recommended for PC
312 specimens with emulative connections.

313 **CONCLUSIONS**

314 Based on test results and analytical analysis, the following conclusions can be drawn:

- 315 1. In general, the load resisting mechanisms of emulative PC frames with emulative connections
316 were similar to that of RC frame. Beam action, compressive arch action, and tensile catenary
317 action were mobilized in sequence for PC frames to resist progressive collapse.
- 318 2. For IA, pulling-out failure prone to occur at the bottom reinforcements near to the middle joint,
319 which prevented the sufficient development of CAA capacity. However, the pulling-out of
320 bottom reinforcements could provide additional TCA capacity, which was beneficial for

321 ultimate load capacity at large deformation stage.

322 3. UB and SA could develop comparable yield load and CAA capacity as that of RC. Comparing
323 to RC frame, PC frames with emulative joints may achieve relatively lower deformation
324 capacity due to higher concrete strength used for cast-in-situ topping layer.

325 4. PC frames with emulative connections had comparable rotation capacity as RC frame and PC
326 beams could provide sufficient tie-force as required by DoD (2010).

327 5. The proposed TCA model was able to predict the TCA capacity reasonably. Both CAA models
328 from Lu et al. (2018) and Yu and Tan (2014) could predict CAA capacity well. However,
329 considering the convenience, Lu et al. (2018)'s model was recommended.

330 **Data Availability**

331 Some or all data, models, or code that support the findings of this study are available from the
332 corresponding author upon reasonable request.

333 **ACKNOWLEDGMENTS**

334 This research was supported by a research grant provided by the Natural Science Foundation of
335 China (Nos. 51778153,52022024). Any opinions, findings and conclusions expressed in this paper
336 are those of the writers and do not necessarily reflect the view of Natural Science Foundation of
337 China.

338 **REFERENCES**

339 ACI (American Concrete Institute). 2014. "Building code requirements for structural concrete
340 (ACI 318-14) and commentary (318R-14)." ACI Committee 318. Farmington Hills, MI: ACI.
341 ASCE. 2010. "Minimum design loads for buildings and other structures." ASCE/SEI 7. Reston,
342 VA: ASCE.

343 DoD (Department of Defense). 2010. "Design of building to resist progressive collapse." UFC 4-
344 023-03. Washington, DC: DoD.

345 GSA (US General Service Administration) 2013. "Progressive collapse analysis and design
346 guidelines for new federal office buildings and major modernization projects." Washington,
347 DC: GSA.

348 Deng, X.F., Liang, S.L., Fu, F. and Qian, K. 2020. "Effects of high-strength concrete on
349 progressive collapse resistance of reinforced concrete frame." *Journal of Structural*
350 *Engineering*, 146(6):4020078

351 Fu, F. 2016. "Structural analysis and design to prevent disproportionate collapse." CRC Press.
352 ISBN 978-1-4987-8820-5.

353 Kang, S. B., and K. H. Tan. 2015. "Behaviour of precast concrete beam–column sub-assemblages
354 subject to column removal." *Eng. Struct.* 93 (Mar): 85-96.

355 Kang, S. B., and K. H. Tan. 2017. "Progressive collapse resistance of precast concrete frames with
356 discontinuous rebar in the joint." *J. Struct. Eng.* 143 (9): 04017090.

357 Lew, H. S., J. A. Main, Y. H. Bao, F. Sadek, V. P. Chiarito, S. D. Robert, and J. O. Torres. 2017.
358 "Performance of precast concrete moment frames subjected to column removal: Part 1,
359 experimental study." *PCI J.* 62 (5): 35-52.

360 Lin, K. Q., Lu, X. Z., Li, Y., Zhou, W. D., and Guan, H. 2019. "A novel structural detailing for the
361 improvement of seismic and progressive collapse performance of RC frames." *Earthquake*
362 *Eng. Struct. Dyn.* 48 (13): 1451-1470.

363 Lu, X. Z., K. Q. Lin, C. F. Li, and Y. Li. 2018. "New analytical calculation models for compressive
364 arch action in reinforced concrete structures." *Eng. Struct.* 168 (Aug): 721-735.

365 Lu, X. Z., K. Q. Lin, Y. Li, H. Guan, P. Q. Ren, and Y. L. Zhou. 2017. "Experimental investigation

366 of RC beam-slab substructures against progressive collapse subjected to an edge-column-
367 removal scenario.” Eng. Struct. 149 (Aug): 91-103.

368 Orton, S., J. O. Jirsa, and O. Bayrak. 2009. “Carbon fiber-reinforced polymer for continuing in
369 existing reinforced concrete buildings vulnerable to collapse.” ACI Struct. J. 106 (5): 608–616.

370 PCI (Precast Prestressed Concrete Institute). PCI design handbook. 7th ed.; 2010.

371 Qian, K., and B. Li. 2018. “Performance of precast concrete substructures with dry connections to
372 resist progressive collapse.” J. Perform. Constr. Facil. 32 (2): 4018005.

373 Qian, K., and B. Li. 2019. “Investigation into resilience of precast concrete floors against
374 progressive collapse.” ACI Struct. J. 116 (2): 171-182.

375 Qian, K., Liang, S.L, Fu, F. and Fang, Q. 2019. “Progressive collapse resistance of precast concrete
376 beam-column sub-assemblages with high-performance dry connections.” Engineering
377 Structures, 198: 109552

378 Qian, K., and B. Li. 2012a. “Dynamic performance of RC beam-column substructures under the
379 scenario of the loss of a corner column—Experimental results.” Eng. Struct. 42 (May): 154-
380 167.

381 Qian, K., and B. Li. 2012b. “Slab effects on response of reinforced concrete substructures after
382 loss of corner column.” ACI Struct. J. 109 (6): 845-855.

383 Qian, K., and B. Li. 2013. “Performance of three-dimensional reinforced concrete beam-column
384 substructures under loss of a corner column scenario.” J. Struct. Eng. 139 (4): 584-594.

385 Qian, K., and B. Li. 2015. “Quantification of slab influence on the dynamic performance of RC
386 frames against progressive collapse.” J. Perform. Constr. Facil. 29 (1): 04014029.

387 Qian, K., B. Li, and J. X. Ma. 2015. “Load-carrying mechanism to resist progressive collapse of
388 RC buildings.” J. Struct. Eng. 141 (2): 04014107.

389 Qian, K., B. Li, and Z. Zhang. 2016. "Influence of multicolumn removal on the behavior of RC
390 floors." *J. Struct. Eng.* 142 (5): 04016006.

391 Qian, K., S. L. Liang, X. Y. Xiong, F. Fu, and Q. Fang. 2020. "Quasi-static and dynamic behavior
392 of precast concrete frames with high performance dry connections subjected to loss of a
393 penultimate column scenario." *Eng. Struct.* 205 (Dec): 110115.

394 Weng, Y. H., K. Qian, F. Fu, and Q. Fang. 2020. "Numerical investigation on load redistribution
395 capacity of flat slab substructures to resist progressive collapse." *Journal of Building
396 Engineering*, 29: 101109.

397 Ren, P. Q., Y. Li, X. Z. Lu, H. Guan, and Y. L. Zhou. 2016. "Experimental investigation of
398 progressive collapse resistance of one-way reinforced concrete beam-slab substructures under
399 a middle-column-removal scenario." *Eng. Struct.* 118 (Apr): 28–40.

400 Sadek, F., J. A. Main, H. S. Lew, Y. H. Bao. 2011. "Testing and analysis of steel and concrete
401 beam-column assemblies under a column removal scenario." *J. Struct. Eng.* 137 (9): 881-892.

402 Sasani M, and S. Sagiroglu. 2008. "Progressive collapse resistance of Hotel San Diego." *J. Struct.
403 Eng.* 134 (3): 478-488.

404 Sasani M. 2008. "Response of a reinforced concrete infilled-frame structure to removal of two
405 adjacent columns." *Eng. Struct.* 30 (Mar): 2478–2491.

406 Shan, S. D., S. Li, S. Y. Xu, and L. L. Xie. 2016. "Experimental study on the progressive collapse
407 performance of RC frames with infill walls." *Eng. Struct.* 111 (Jan): 80-92.

408 Stevens, D., B. Crowder, D. Sunshine, K. Marchand, R. Smilowitz, E. Williamson, and M.
409 Waggoner. 2011. "DoD research and criteria for the design of buildings to resist progressive
410 collapse." *J. Struct. Eng.* 137 (9): 870-880.

411 Su, Y. P., Y. Tian, and X. S. Song. 2009. "Progressive collapse resistance of axially-restrained

412 frame beams.” *ACI Struct. J.* 106 (5): 600-607.

413 Valipour, H., N. Vessali, S. J. Foster, and B. Samali. 2015. “Influence of concrete compressive
414 strength on the arching behaviour of reinforced concrete beam assemblages.” *Advances in
415 Structural Engineering*, 18 (8): 1199-1214.

416 Yu, J., and K. H. Tan. 2013. “Structural behavior of RC beam-column sub-assemblages under a
417 middle column removal scenario.” *J. Struct. Eng.* 139 (2): 233–250.

418 Yu, J., and K. H. Tan. 2014. “Analytical model for the capacity of compressive arch action of
419 reinforced concrete sub-assemblages.” *Magazine of Concrete Research*, 66 (3): 109–126.

420 Yu, J., and K. H. Tan. 2017. “Structural behavior of reinforced concrete frames subjected to
421 progressive collapse.” *ACI Struct. J.* 114 (1): 63–74.

422 Yu, J., Luo, L. Z., and Fang, Q. 2020. “Structural behavior of reinforced concrete beam-slab
423 assemblies subjected to perimeter middle column removal scenario.” *Eng. Struct.* 208: 110336.

424 Yu, J., T. Rinder, A. Stolz, K. H. Tan, and W. Riedel. 2014. “Dynamic progressive collapse of an
425 RC assemblage induced by contact detonation.” *J. Struct. Eng.* 140 (6): 04014014.

426

427

428

429

430

431

432

433

434

435
436
437
438
439

Table 1. Frame Details

Test ID	Reinforcing details in middle joint	Beam clear span (mm)	Span/depth ratio	Beam longitudinal rebar			
				A-A section		B-B section	
				Top	Bottom	Top	Bottom
RC	Continuity	2750	11	3T12	2T12	2T12	2T12
IA	Insufficient anchorage	2750	11	3T12	2T12	2T12	2T12
SA	Sufficient anchorage	2750	11	3T12	2T12	2T12	2T12
UB	U-shaped bar	2750	11	3T12	4T12	2T12	2T12

440
441

Table 2. Material Properties of Rebar

Items		Nominal diameter (mm)	Yield strength (MPa)	Ultimate strength (MPa)	Elongation (%)
Transverse rebar	R6	6	346	485	18.4
Longitudinal	T12	12	438	576	15.3
reinforcements	T16	16	466	603	16.8

442 Note: R6 represents plain rebar with diameter of 6 mm; T12 and T16 represent deformed rebar with diameter of 12
443 mm and 16 mm, respectively.

444

Table 3. Test Results

Test ID	MJD at FPL (mm)	MJD at UL (mm)	Resistance re-ascending (kN)	FPL (kN)	UL (kN)	MHCF (kN)	MHTF (kN)	F _p (kN)
RC	90	712	280	52	94	-178	154	63
IA	68	690	266	42	98	-158	172	63
SA	66	660	220	51	81	-176	162	63
UB	76	651	244	48	75	-169	138	63

445 Note: MJD represents vertical displacement; FPL and UL represent first peak load and ultimate load, respectively;
446 MHTF and MHCF represent maximum horizontal tensile force and maximum horizontal compressive force,
447 respectively. F_p is the required peripheral tie force.

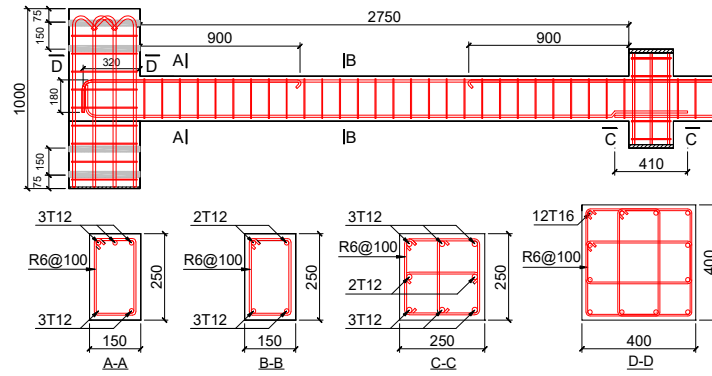

(a)

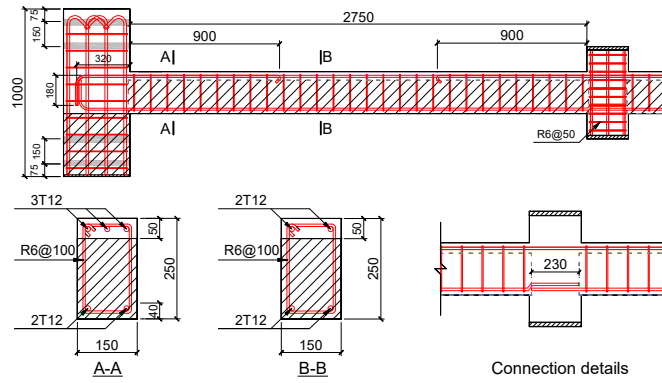

(b)

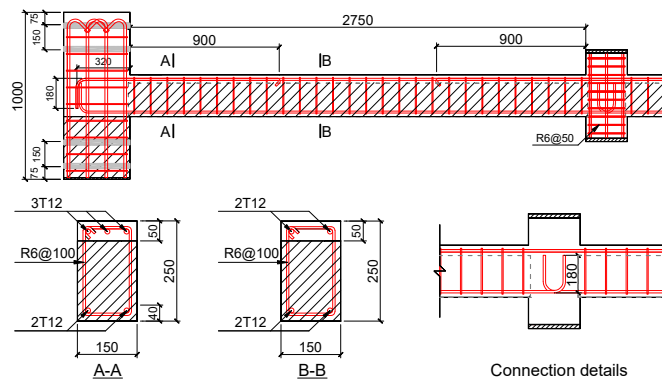

(c)

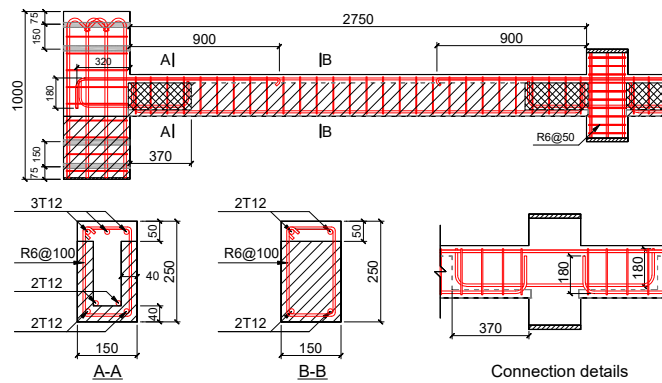

(d)

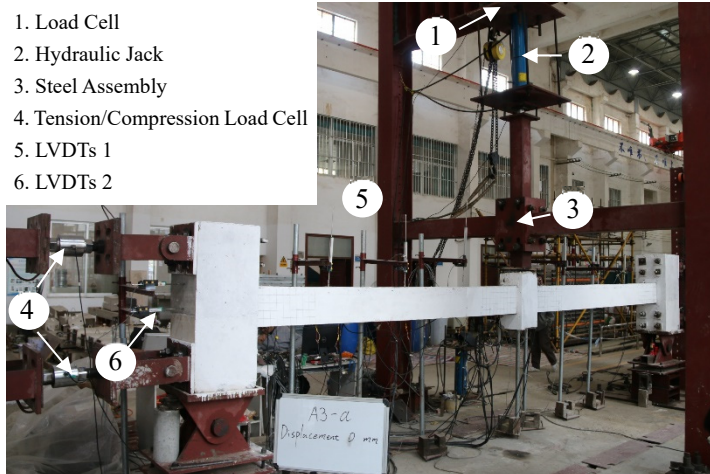

(a)

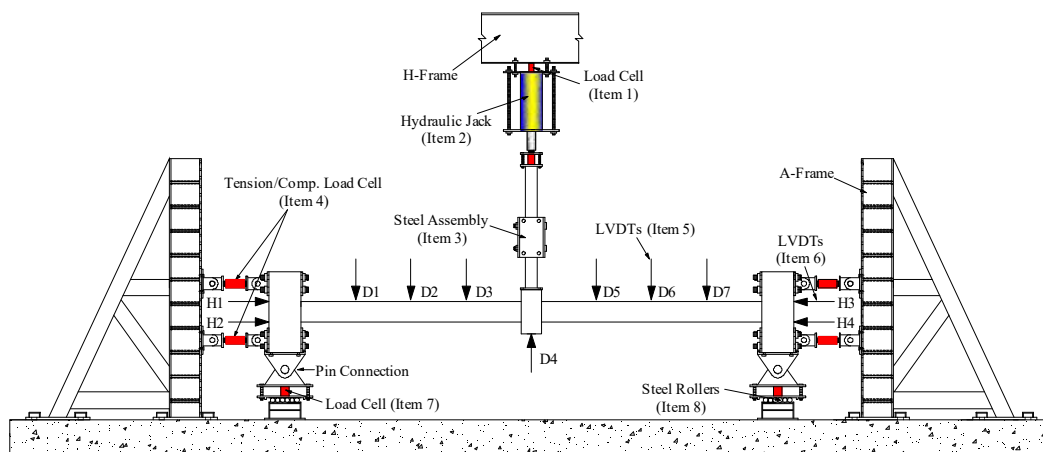

(b)

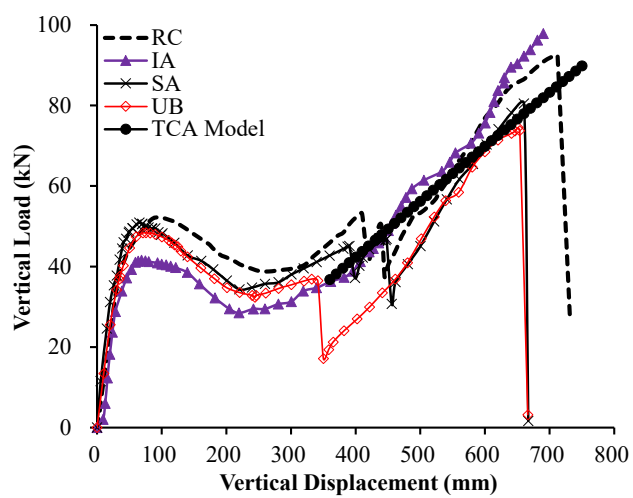

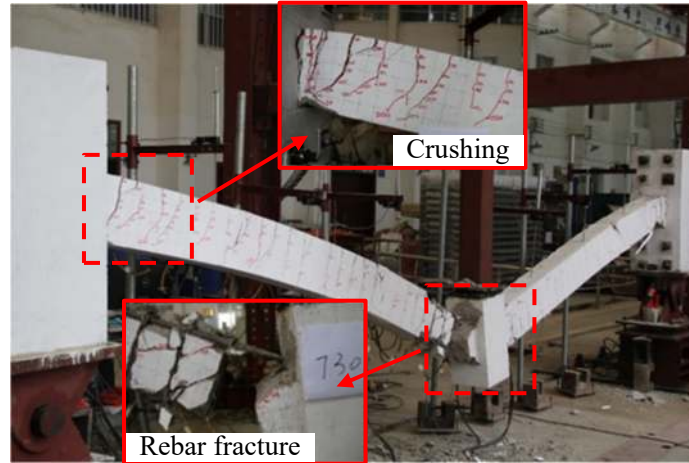

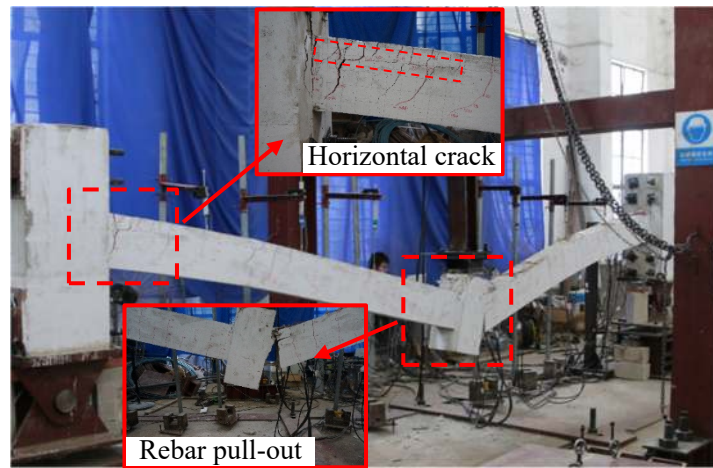

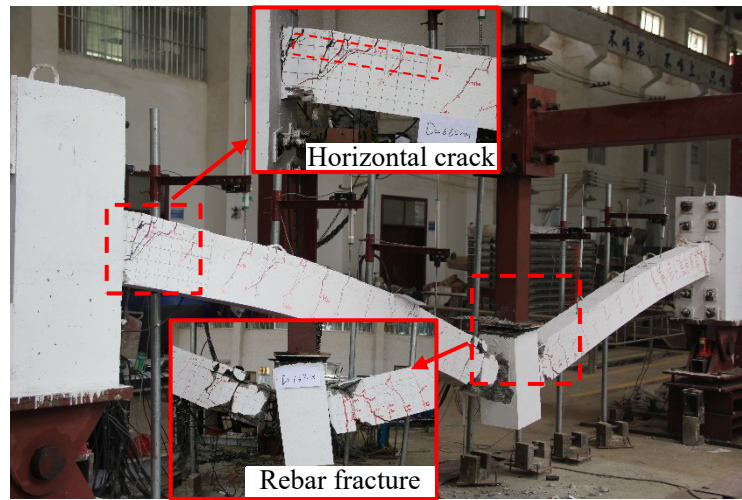

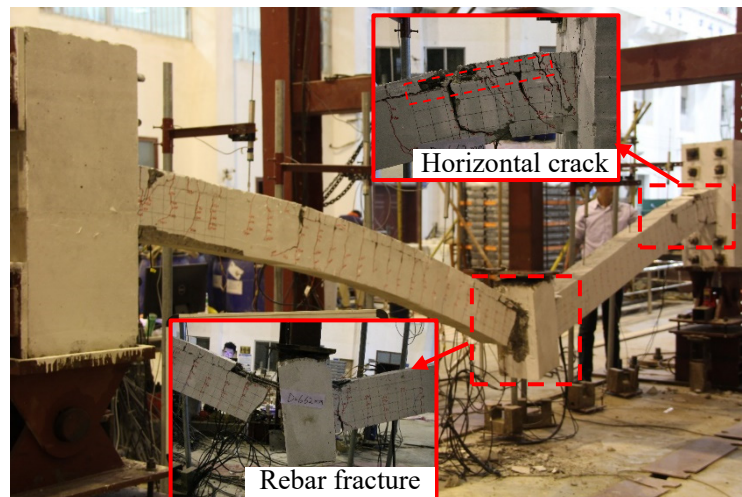

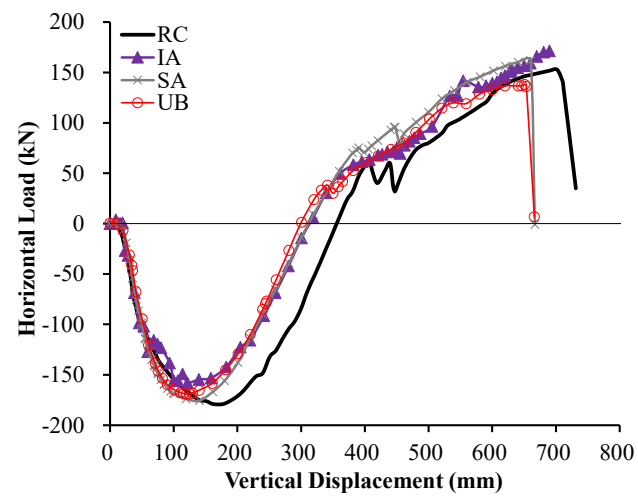

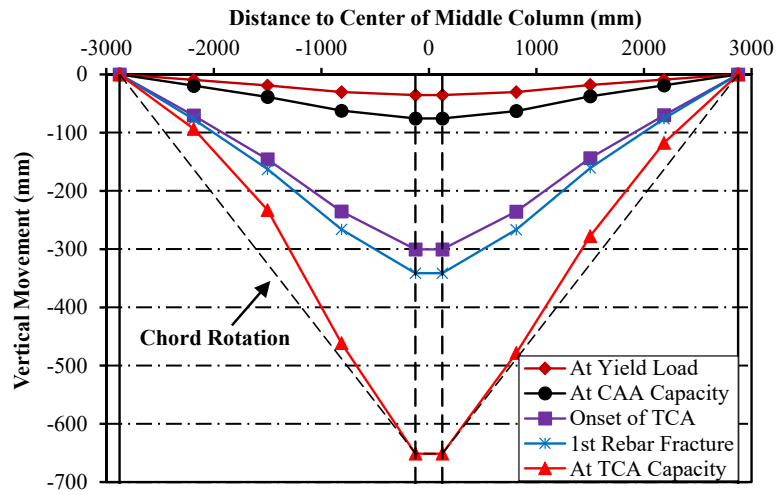

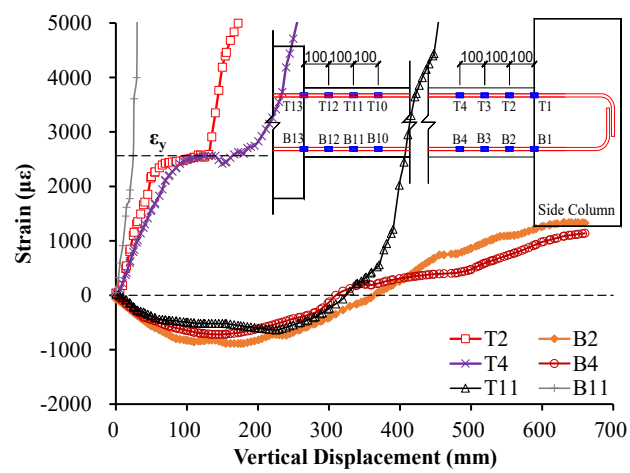

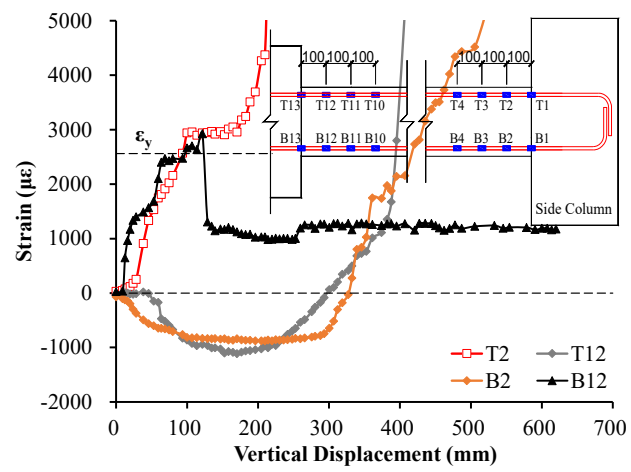

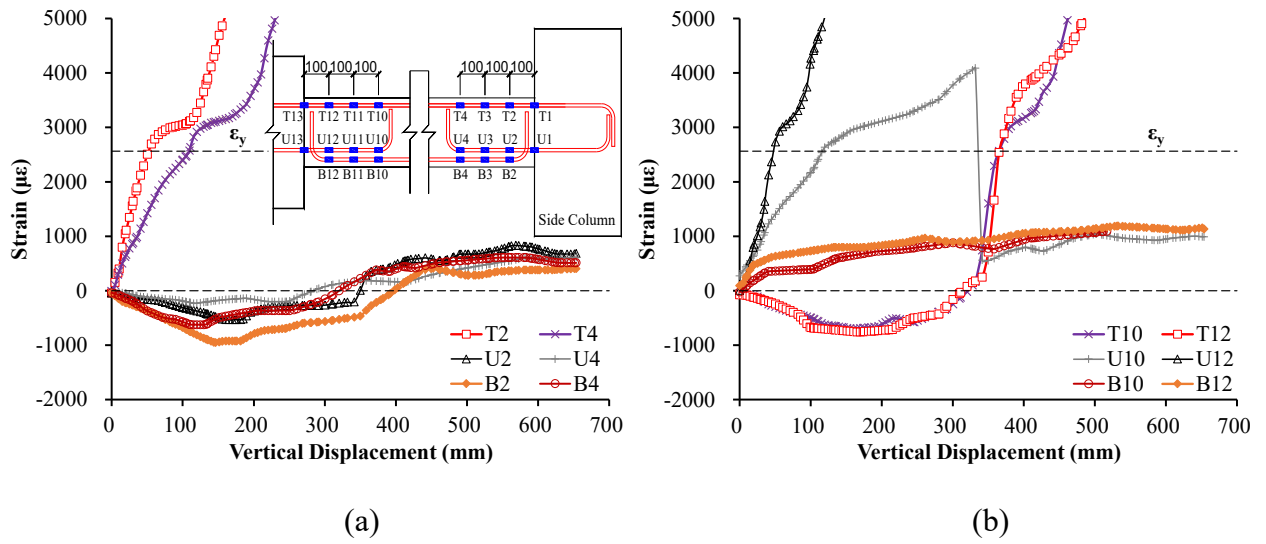

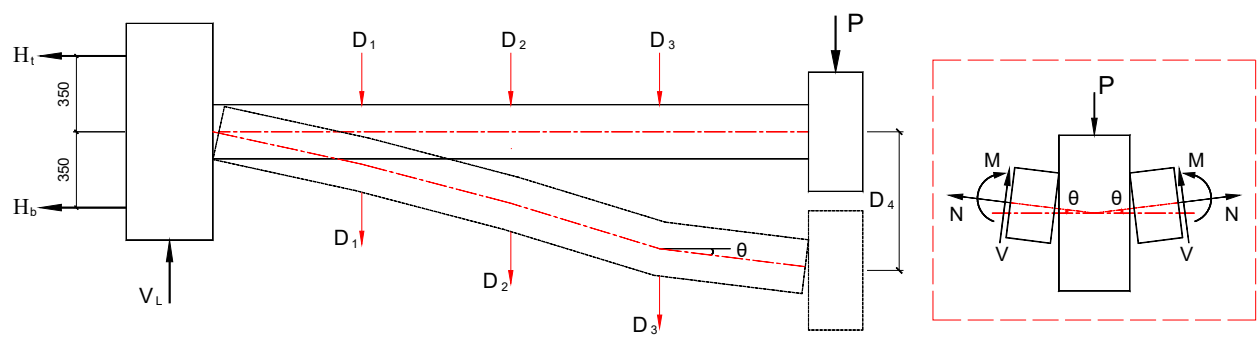

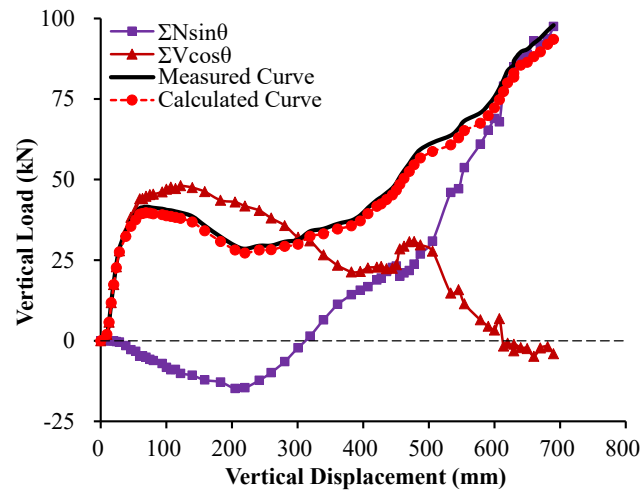

(a)

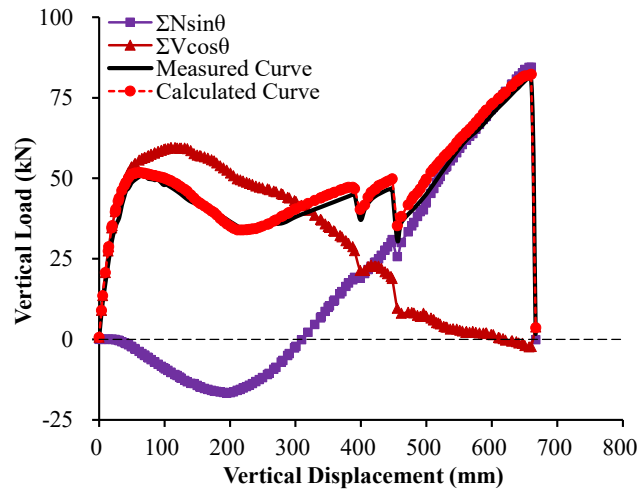

(b)

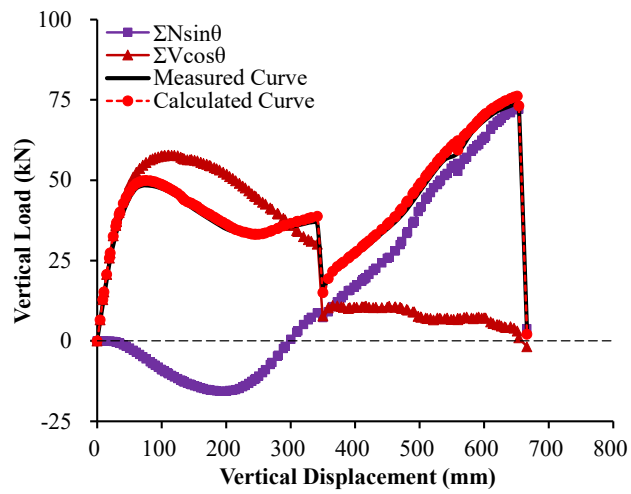

(c)

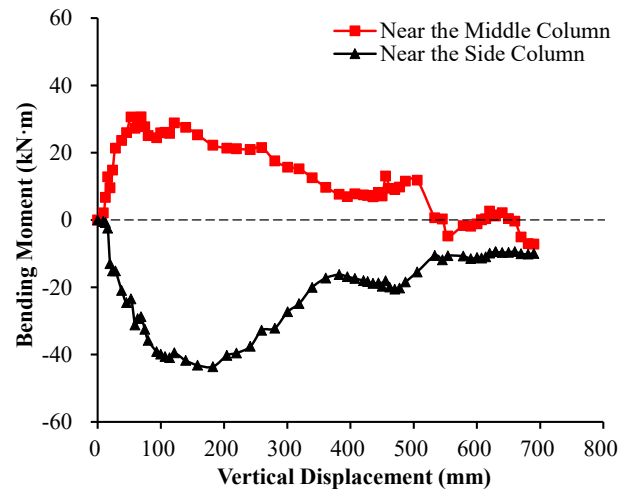

(a)

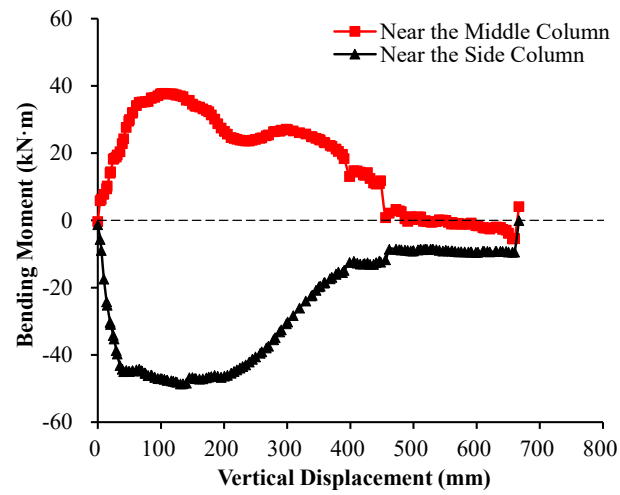

(b)

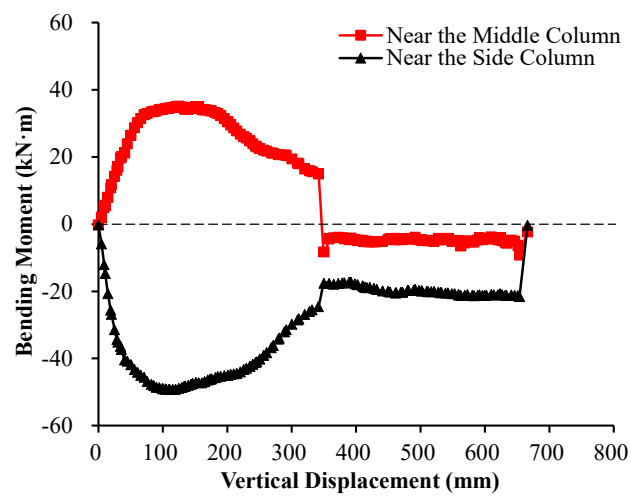

(c)

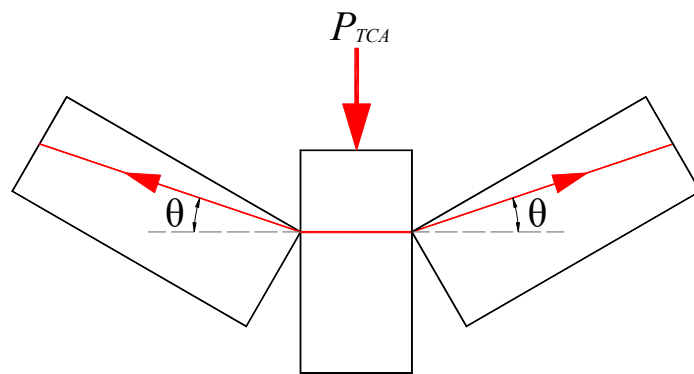

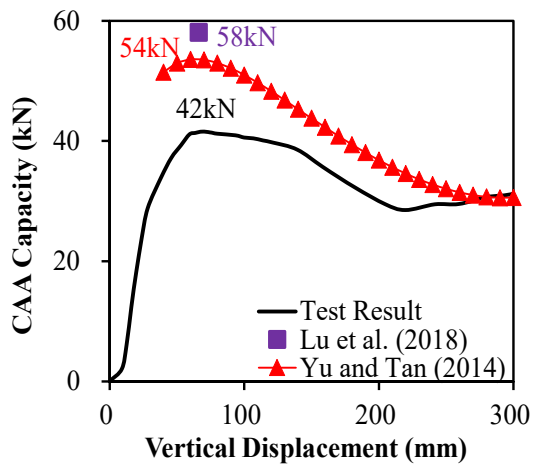

(a)

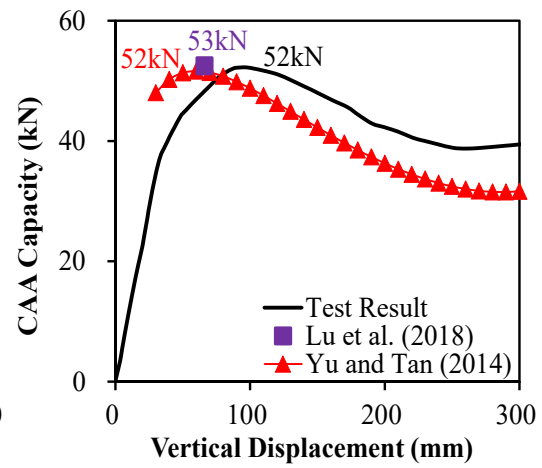

(b)

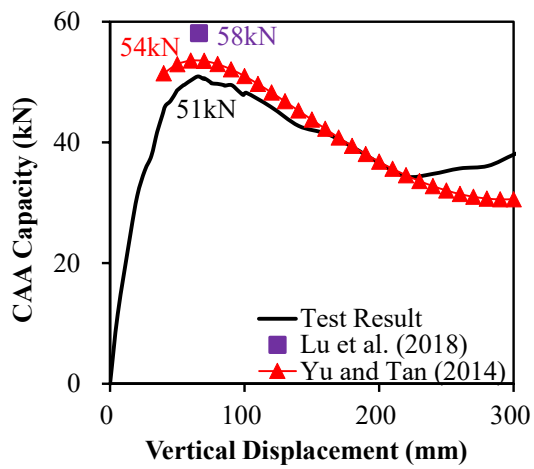

(c)

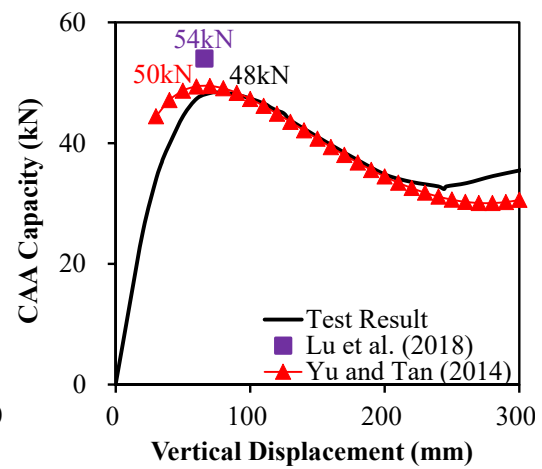

(d)

Figure Captions

Fig. 1. Details of test frame: (a) RC; (b) IA; (c) SA; (d) UB

Fig. 2. Test setup: (a) photo, (b) drawing

Fig. 3. Vertical load-displacement curves

Fig. 4. Failure mode of RC

Fig. 5. Failure mode of IA

Fig. 6. Failure mode of SA

Fig. 7. Failure mode of UB

Fig. 8. Horizontal reaction force-displacement curves

Fig. 9. Deformation shape of double-span beam of UB

Fig. 10. Strain of beam rebar in SA

Fig. 11. Strain of beam rebar in IA

Fig. 12. Strain of beam rebar in UB: (a) near the side column; (b) near the middle column

Fig. 13. Relationship between internal forces at critical section and load resistance

Fig. 14. Load resistance de-composition: (a) IA; (b) SA; (c) UB

Fig. 15. Bending moment at the beam ends: (a) IA; (b) SA; (c) UB

Fig. 16. Proposed TCA model

Fig. 17. Comparison of measured CAA capacity with theoretical one: (a) IA; (b) RC; (c) SA; (d) UB