



# LUND UNIVERSITY

## Properties of Materials at High Temperatures Steel

Anderberg, Yngve

1983

[Link to publication](#)

*Citation for published version (APA):*

Anderberg, Y. (1983). *Properties of Materials at High Temperatures Steel*. (LUTVDG/TVBB--3008--SE; Vol. 3008). Division of Building Fire Safety and Technology, Lund Institute of Technology.

*Total number of authors:*

1

### General rights

Unless other specific re-use rights are stated the following general rights apply:

Copyright and moral rights for the publications made accessible in the public portal are retained by the authors and/or other copyright owners and it is a condition of accessing publications that users recognise and abide by the legal requirements associated with these rights.

- Users may download and print one copy of any publication from the public portal for the purpose of private study or research.
- You may not further distribute the material or use it for any profit-making activity or commercial gain
- You may freely distribute the URL identifying the publication in the public portal

Read more about Creative commons licenses: <https://creativecommons.org/licenses/>

### Take down policy

If you believe that this document breaches copyright please contact us providing details, and we will remove access to the work immediately and investigate your claim.

LUND UNIVERSITY

PO Box 117  
221 00 Lund  
+46 46-222 00 00

rilem



Lund Institute  
of Technology

PROPERTIES OF MATERIALS AT  
HIGH TEMPERATURES  
STEEL

Edited by

Y Anderberg



RILEM-COMMITTEE 44-PHT

BEHAVIOUR OF STEEL AT HIGH  
TEMPERATURES

by

Yngve Anderberg

February 1983

Members of the committee:

H.L. Malhotra (Chairman), United Kingdom

Y. Anderberg, Sweden

B. Alexander, United Kingdom

D. Cluzel, France

G. Gantvoort, Holland

S. Hadvig, Denmark

Ch. Hildebrand, Leipzig, GDR

P.J. Hovde, Norway

J. Lindner, Poland

A. Cavaleiro e Silva, Portugal

U. Schneider, Kassel, FGR



## FOREWORD

During mid-seventies international discussions indicated that research into fire and fire behaviour of structures was being pursued by a number of international organizations; a Commission of CIB (W14) was studying basic fire phenomena and had been asked by the liaison committee of the international engineering associations to provide a common approach for the design of structures against fire. Various materials committees were starting work on design codes and CIB/W14 set up a Code Advisory Panel to provide some general principles. A directorate of the EEC Commission started activity on the harmonization of fire test standards and fire safety codes. The fire test standards were prepared by the ISO Technical Committee TC 92. One obvious omission in this system was the absence of agreed data on material properties which could be used in the structural design codes. An approach was made to the RILEM Permanent Committee, as the General Council was known at that time, to initiate a technical committee to deal with this topic. Approval was given in 1977 for the formation of Committee 44 - PHT and it met for the first time in April 1978. The active membership of the committee came from many countries as the list on the inside front page shows. Over a period of 5 years the committee held 10 meetings, including a special seminar in the middle of 1982 in the Hague.

When examining the range of materials to be studied, maximum emphasis was placed on the major materials of construction, i.e. concrete, masonry, steel and wood but others having an important role in the building construction were also included. However it was necessary to keep the work within manageable proportions and the maximum effort was devoted to the study of concrete and steel. The list of materials examined is as follows:

Concrete; dense and lightweight,  
Steel; structural, reinforcing and prestressing,  
Wood; soft and hardwoods,  
Masonry; brick and concrete blocks,  
Plastics; constructional,  
Gypsum; plaster and board.

The amount of data available on concrete and steel was large and it required much effort on the part of the specialist panels to consolidate the information. For steel this task was undertaken by Dr. Y. Anderberg who also edited the final document. The amount of data was so extensive that it became difficult for the RILEM secretariat with its limited resources to publish it. Lund Institute of Technology has kindly come to our assistance and agreed to publish the information so that it may become available to individuals and associations who are interested in this field. I wish to express my personal thanks and those of the RILEM Secretariat to Dr. Anderberg and the Division of Building Fire Safety and Technology for this most valuable help.

The document is unique in presenting information for the first time in this collective form and in a way that direct comparisons can be made. It has also highlighted areas where further research may be successfully carried out. Determination of the physical properties under transient heating conditions and their expression as a mathematical model will assist fire engineers in the design and analysis of structures exposed to fire conditions.

I appreciate the valuable help given by all committee members of 44 - PHT during our meeting in various host institutes and my only regret is that we were not able to complete the work on some of the other materials. Data on concrete is being published simultaneously. No doubt another RILEM technical committee will be able to take in on board.

H.L. Malhotra  
Chairman 44 - PHT

# C o n t e n t

## Preface

### Part I: Introduction

	Page
1 Background	1
2 Different methods of testing	2
2.1 Steady state tests	3
2.1.1 $\sigma$ - $\epsilon$ relationship, stress rate controlled	4
2.1.2 $\sigma$ - $\epsilon$ relationship, strain rate controlled	4
2.1.3 Creep	5
2.1.4 Relaxation	5
2.2 Transient tests	5
2.2.1 Failure temperature, total deformation	6
2.2.2 Restraint forces	6

### Part II: Steel properties

3 Particular properties	18
3.1 Tensile strength	18
3.2 Modulus of elasticity	40
3.3 Thermal strain	48
3.4 Creep strain	51
3.5 Stress-strain characteristics	57
3.5.1 Steady state data	57
3.5.2 Transient state data	77
3.6 Relaxation	93



	Page
3.7 Thermal properties	97
3.8 Residual properties	102
4 A review and comparative study of different properties	108
5 Analytical modelling	114
5.1 Models	114
5.2 Comparison test and calculation	116
5.3 How to compare results obtained at different test procedures	127

### Part III: Steel literature

6 References	0
6.1 Particular properties	I
6.1.1 General properties	I
6.1.2 Tensile strength	VII
6.1.3 Modulus of elasticity	XI
6.1.4 Thermal strain	XIII
6.1.5 Creep strain	XIV
6.1.6 Stress-strain characteristics	XVI
6.1.6.1 Steady state tests	XVI
6.1.6.2 Transient tests	XVIII
6.1.7 Compressive strength	XIX
6.1.8 Relaxation	XX
6.1.9 Thermal properties	XXI
6.1.10 Residual properties after cooling	XXIII
6.2 Structural behaviour	XXV
6.3 Analytical models	XXVI
6.3.1 Material behaviour	XXVI
6.3.2 Structural behaviour	XXVII
7 Symbols and abbreviations	XXIX

## Preface

The objectives of the technical committee are to identify those properties and characteristics, which are of importance, survey the existing knowledge, evaluate the data and the relevant literature, suggest activity in areas not already covered and provide facilities for the dissemination of information in papers and by discussion.

In this report the main features of the behaviour of steel at high temperature are summarized and discussed. The report is divided into three parts:

- Part I - INTRODUCTION
- Part II - STEEL PROPERTIES
- Part III - STEEL LITERATURE

### Part I: INTRODUCTION

#### 1 Background

Many investigations on mechanical properties of steels at high temperatures have been reported during the last 30 years. However, the results are sometimes hard to interpret and to compare with other investigations due to the fact that

- test specimens are different (variation in chemical composition, shape and size)
- descriptions are incomplete
- test procedures differ
- test conditions are not comparable
- unsatisfactory accuracy and reliability of testing equipment.

Therefore, it is useful to try to clarify and elucidate the main characteristics and features of steel behaviour and the different test methods used.

A careful distinction is made between stabilized temperature tests and transient tests, and also between hot-rolled and cold-worked reinforcing steel and structural and prestressing steel. These steels behave in many ways differently. The most important properties are discussed and a comparative study is made of test results from different sources. The paper also briefly discusses analytical models of steel. In many papers one agrees to the fact that in a deformation process of steel the total strain can be separated into three components, i.e. thermal strain, instantaneous stress-related strain and creep strain. These strains are also discussed separately.

In the list of references the properties of steel are divided into a number of main headings following the same sequence as in chapter 3. Further, each property includes subheadings, which separate the three categories of steel, i.e. structural steel, reinforcing steel and prestressing steel. A few references to other materials such as cast iron are included. The reference list also contains sections on structural behaviour and analytical models of steel and steel structures.

## 2 Different methods of testing

There exist two main groups of tests, steady state tests and transient tests. Material properties measured are closely related to the test method used. It is therefore of great importance that the test conditions are well defined.

During a fire situation the material is normally subjected to transient processes with varying temperature and stress, and to understand this, transient tests are needed. Steady state tests cannot be used solely to explain the stress-strain characteristics of steel in all cases.

Mechanical properties of steel can be established by following a number of different test procedures. The three main test parameters are the heating process, application and control of load, and control of strain. These can have constant values or be varied during testing, giving steady state or transient conditions depending on the heating procedure.

Six practical regimes which can be used for determining mechanical properties are illustrated in Fig. 1. Properties in these regimes are as follows:

steady state tests

- stress-strain relationship (stress rate controlled)
- stress-strain relationship (strain rate controlled)
- creep
- relaxation

transient tests

- total deformation, failure temperature (stress control)
- total forces, restraint forces (strain control).

### 2.1 Steady state tests

Steady state tests are characterized by a heating period,  $t_H$ , and a period of time,  $t_S$ , during which the temperature of the specimen is stabilized before any load is applied, as shown in Fig. 2. The time  $t_S$  depends on the size of the specimen, but is usually not more than 0.5 h. The strain measured before the load is applied corresponds to the thermal expansion.

After time  $t_H + t_S$  the temperature is kept constant and four types of steady state tests are usually carried out as indicated above. Properties related to these tests are described below.

### 2.1.1 $\sigma$ - $\epsilon$ relationship, stress rate controlled

After the stabilized period of heating, the specimen is subjected to a constant rate of loading until failure occurs (see Fig. 3a). The data obtained provide  $\sigma$ - $\epsilon$  relationships at different temperatures of the type shown in Fig. 3b and can be used to establish compressive or tensile strength, modulus of elasticity and ultimate strain at collapse. For prestressing steels, however, there exists no yielding plateau as indicated in Fig. 3b. The stress-strain relationship is often obtained at a high rate of loading,  $\dot{\sigma}$ , (loading time 1-2 minutes) in order to avoid the influence of creep, which is of importance above about 400°C for ordinary steel (for cold-worked steel above about 250°C). The influence of creep results in a displaced  $\sigma$ - $\epsilon$  curve and a lower ultimate (rupture) strength, which will be illustrated in chapter 4.

### 2.1.2 $\sigma$ - $\epsilon$ relationship, strain rate controlled

$\sigma$ - $\epsilon$  relationships measured under strain rate control are closely related to the test described above. After the stabilized period of heating the specimen is loaded at a specified strain rate,  $\dot{\epsilon}$ , as indicated in Fig. 4a. This test yields  $\sigma$ - $\epsilon$  curves as illustrated in Fig. 4b. Depending on the strain rate, the influence of creep above a certain temperature level yields differing  $\sigma$ - $\epsilon$  curves. This will be illustrated in chapter 4.

In these kinds of tests the maximum stress is reached for a given strain and at higher strains the stress decreases somewhat with failure occurring at much greater strains than in the corresponding stress controlled  $\sigma$ - $\epsilon$  tests. The  $\sigma$ - $\epsilon$  curves obtained not only provide properties mentioned in 2.1.1, but also mechanical dissipation energy. The ultimate strain, however, is related to the maximum stress level and not to the failure state.

### 2.1.3 Creep

When the desired temperature is attained in a creep test, the specimen is loaded and the load is then kept constant during the whole test period as shown in Fig. 5a. At the time  $t_H + t_S$ , when the load is applied, the immediate response results in an instantaneous elastic strain and thereafter a deformation as function of time, i.e. creep, takes place, which is illustrated at different temperatures in Fig. 5b. The test period of interest during a fire is usually from 2-4 hours. A typical creep curve is shown in Fig. 6 indicating that the creep process contains three phases, i.e. primary, secondary and a tertiary phase. Normally, only the initial creep, i.e. the primary and the secondary phase, are studied.

### 2.1.4 Relaxation

A relaxation test is closely related to a creep test, but when the specimen has been loaded the initial strain is kept constant and the decrease in stress is measured during the whole test period. Fig. 7a illustrates the whole strain history. The reduction of stress or relaxation as function of time, which is due to the creep, is shown in Fig. 7b. Normally, a period of 2-4 hours is of interest during fire situations.

## 2.2 Transient tests

Transient temperature tests or non-steady state tests are characterized by a varying temperature (often increasing linearly, see Fig. 8) and a simultaneous load. The load can be applied before heating or developed during heating by restraint against thermal expansion. These two types of transient tests are carried out with load and strain control, respectively. The second alternative appears only in compression. Properties related to these tests are described below.

### 2.2.1 Failure temperature, total deformation

A load is applied to the specimen before heating; heating proceeds at a specified rate ( $\dot{T} = 5\text{-}50^{\circ}\text{C}/\text{min}$ ) until failure occurs. Usually, the load is constant as shown in Fig. 9a. Total deformation as a function of time is recorded until the failure point, i.e. when the strain rate or total strain is approaching infinity. The temperature measured at that critical point is called the failure (critical) temperature. Typical results are illustrated in Fig. 9b for different load levels. The result is very much influenced by the rate of heating as creep cannot be avoided. The curves enable failure temperatures which provide strength/temperature relationships to be found in Fig. 9c. Similar relationships can be obtained from steady state  $\sigma\text{-}\epsilon$  curves.

If one plots the total deformation minus the thermal strain, against the temperature, one obtains curves as illustrated in Fig. 9d. From these curves,  $\sigma\text{-}\epsilon$  relationships can be constructed in which the creep strain corresponding to a specified heating rate is included, Fig. 9e. The heating rate has a great influence on these  $\sigma\text{-}\epsilon$  curves, just as the strain rate has in steady state  $\sigma\text{-}\epsilon$  tests. This is illustrated in chapter 3.5.2 and 4.

### 2.2.2 Restraint forces

If the deformation is kept constant during a transient heating process, restraint forces arise. The deformation can be zero or correspond to the initial strain response of load application before heating as indicated in Fig. 10a. In such a strain controlled transient test at temperatures above about  $550\text{-}600^{\circ}\text{C}$ , the total force (initial load + restraint force) is independent of the initial load, which can also be zero, see Fig. 10b. If the total load minus the initial load is considered, one will obtain differing curves depending on the varying influence of creep. Measurements of restraint forces can only be carried out on steel structures with no buckling influence, i.e. very short columns.

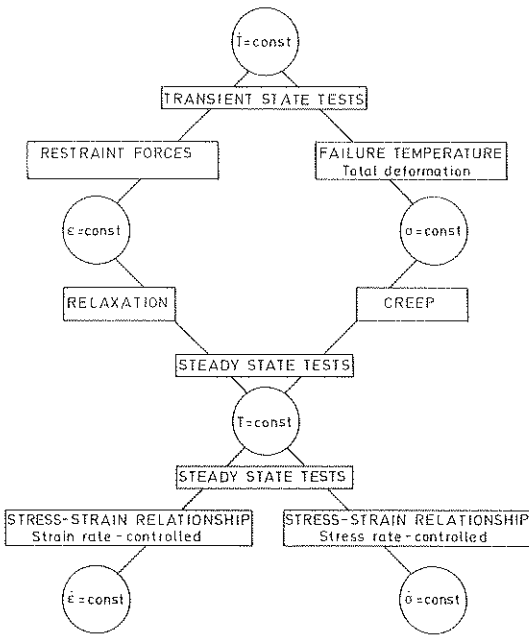

Fig 1 Different testing regimes for determining mechanical properties



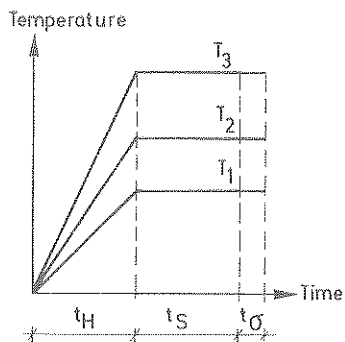

Fig 2 Typical steady state temperature curve

$t_H$  = heating period

$t_S$  = stabilizing period

$t_\sigma$  = loading period (1-3 minutes)

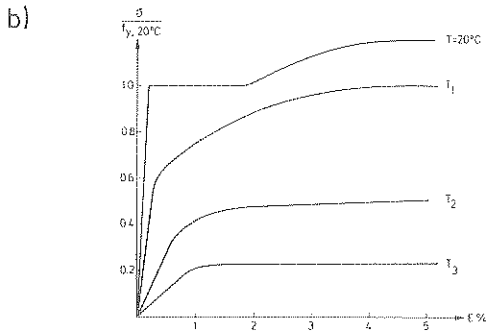
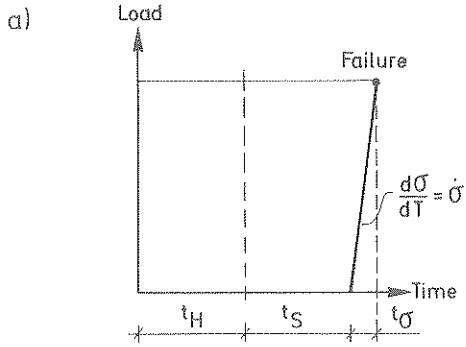

Fig 3 Stress rate controlled  $\sigma$ - $\epsilon$  tests

- a) Loading procedure
- b) Typical results

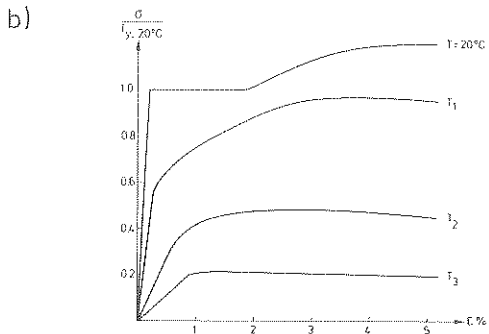
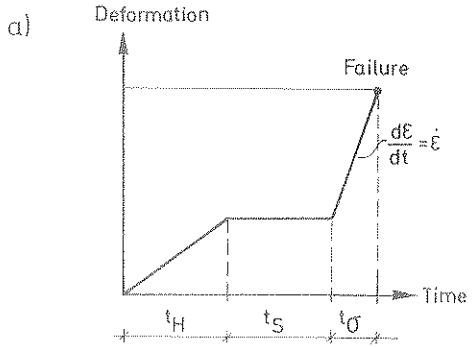

Fig 4 Strain rate controlled  $\sigma$ - $\epsilon$  tests  
a) Deformation procedure  
b) Typical results

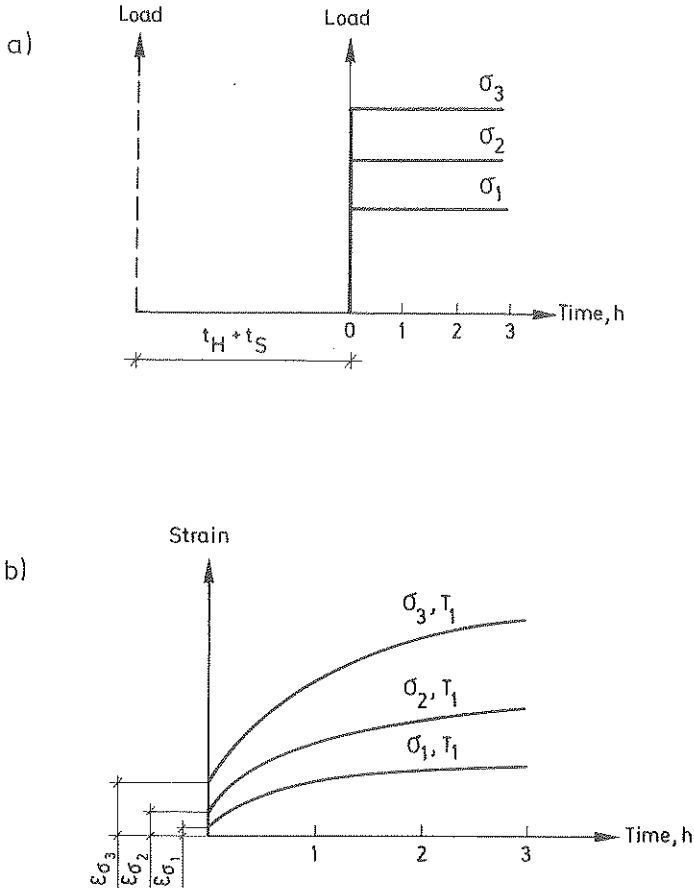

Fig 5 Creep tests

a) Loading procedure

b) Typical results

$\epsilon_{\sigma}$  - instantaneous stress-related strain

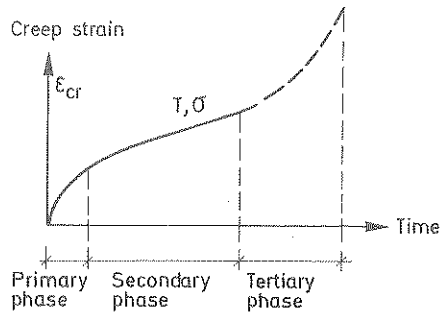

Fig 6 Typical creep curve

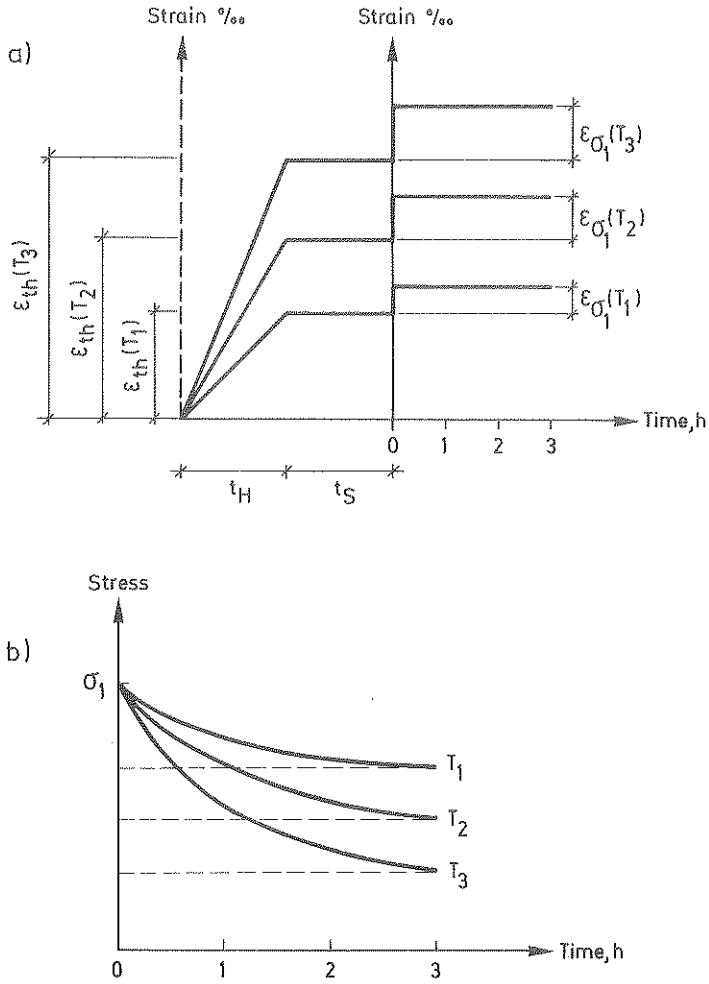

Fig 7 Relaxation tests  
a) Strain history  
b) Typical results

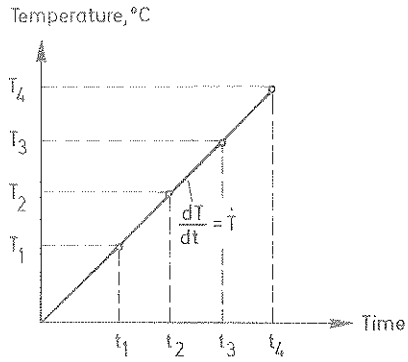

Fig 8 Typical transient state temperature curve

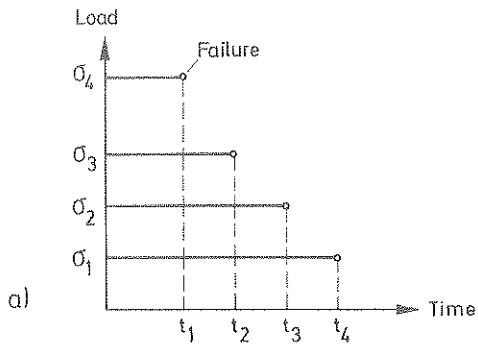

Fig 9 Transient tests with load control

a) Load history

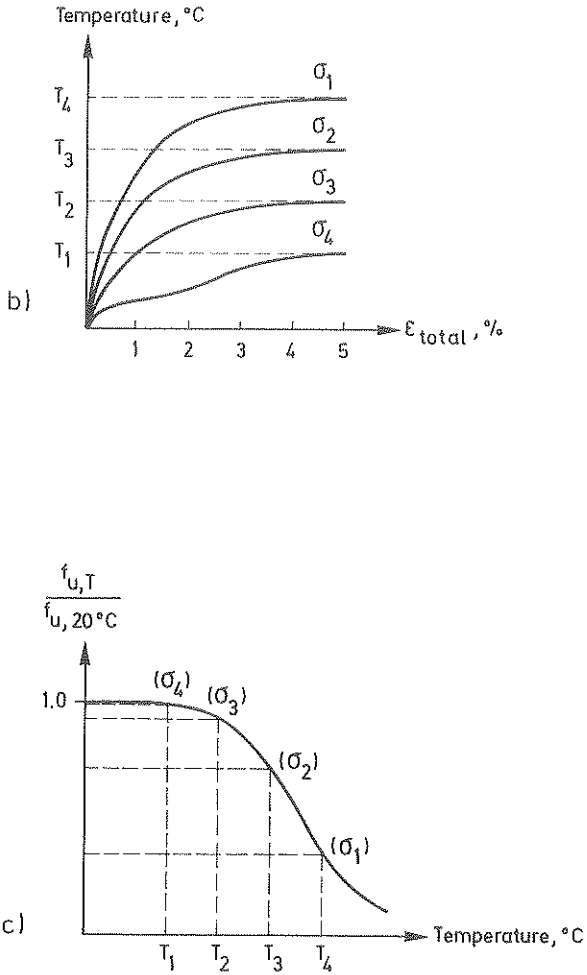

Fig 9 Transient tests with load control

b) Typical deformation curves

c) Typical strength-temperature relationships



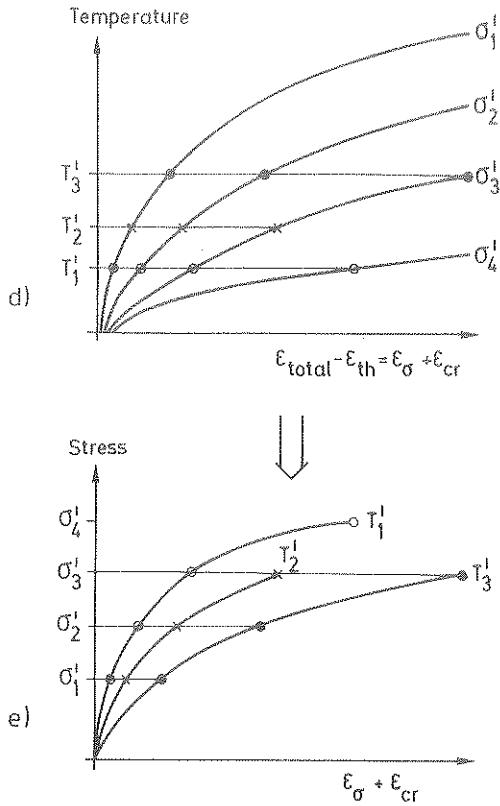

Fig 9 Transient tests with load control

d) Typical  $\epsilon$ - $T$  curves at four different stress levels.

$$\epsilon = \epsilon_{tot} - \epsilon_{th}$$

e) Calculated  $\sigma$ - $\epsilon$  curves (including creep) at different temperatures

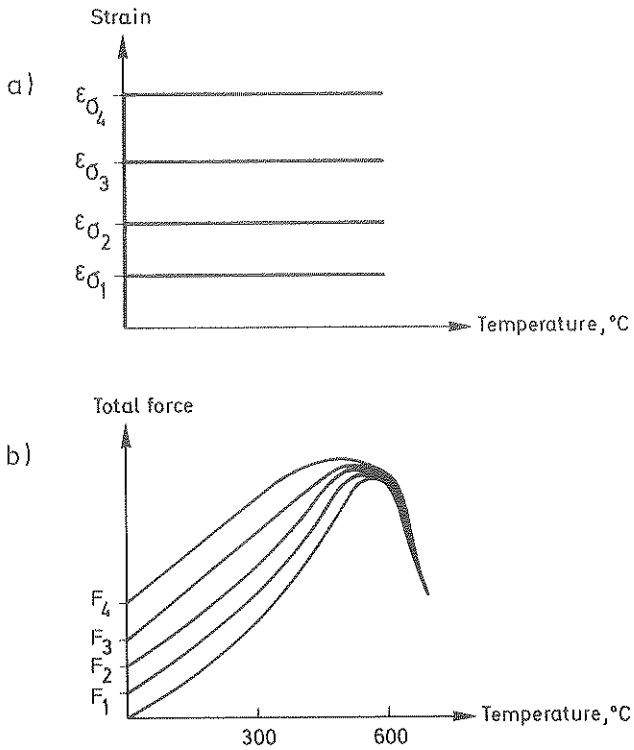

Fig 10 Transient tests with strain control  
a) Strain history  
b) Typical curves of restraint forces

Part II: STEEL PROPERTIES

3 Particular properties

Properties of steel obtained or derived from different tests described above are collected in this chapter. The data are based on a literature survey and the source can always be found in the reference list in part III, chapter 6.

The presentation is based on relevant data as far as possible and the basic test conditions and the strength characteristics, the chemical composition (when available) and the reference are always given. This is a screening of individual reports on reinforcing, structural and prestressing steel, and further data may continuously appear in future.

3.1 Tensile strength

It is not only important to define the precise meaning of tensile strength, but also to define the type of test whether steady state or transient state. It can be the ultimate tensile strength,  $f_u$  (rupture strength), or the tensile strength related to a specified residual stress induced strain in the  $\sigma$ - $\epsilon$  curve as principally illustrated in Fig 11. The stress which produces for instance a residual strain of 0.2% is called the 0.2% proof stress or the yield stress,  $\sigma_{0.2}$ , although the yielding plateau for hot-rolled steels disappears at temperatures above 300°C. When the strength is defined by the proof stress for a given residual, non-recoverable strain, for instance 0.2% and 0.5%, it will be denoted  $f_{0.2}$  and  $f_{0.5}$ .

When the ultimate strength is measured in a transient test with constant load control it can either be related to the critical temperature when the strains reach infinite values or to a strain rate criteria, for instance  $\dot{\epsilon} = 1.0 \cdot 10^{-4} \cdot s^{-1}$ . If it is connected to a strain rate criteria this will be specially indicated when presenting data. The ultimate strength and proof stress are obtained from  $\sigma$ - $\epsilon$  curves at different temperature levels or from load controlled transient tests as described in chapter 2.2.1

Depending on the test procedure the creep may influence the strength-temperature curve and, therefore, it must be considered when comparing such curves from different laboratories. The creep results in a decreased value of the tensile strength above about 250°C and 400°C for cold-worked and hot-rolled steel, respectively.

Parameters of importance in an analysis of the tensile strength are

in steady state  $\sigma$ - $\epsilon$  tests

- rate of stress,  $\dot{\sigma}$ , at stress rate control
- rate of strain,  $\dot{\epsilon}$ , at strain rate control

and in load controlled transient tests

- rate of temperature increase,  $\dot{T}$
- strain rate criteria.

Depending on the test characteristics the influence of creep is different.

A general conclusion is that the relative decrease in tensile strength of all hot-rolled and prestressing steels is almost the same, which means that the original strength has little influence on the strength-temperature curve. The 0.2% proof stress and the ultimate strength of such steels obtained in steady state and transient state tests have at 500-550°C 50% of its original value left, and at 700°C about 20%. For prestressing steel the 50 and 20% limits are reached at 350-400°C and 500°C, respectively. Fig. 11 indicates that cold-worked steel has a higher strength-temperature curve. Too little data are available to make a certain conclusion.

The influence of strain rate,  $\dot{\epsilon} = 0.1-100 \cdot 10^{-3} \cdot \text{min}^{-1}$ , is illustrated in Fig 8 and at  $600^{\circ}\text{C}$  the strength value varies from  $0.65$  to  $0.3 \cdot f_{0.2, 20^{\circ}\text{C}}$ . In Fig 9 different rates of loading,  $0.03-1.63 \text{ MPa/s}$ , result in strength values  $0.35-0.25 \cdot f_{0.2, 20^{\circ}\text{C}}$  at  $600^{\circ}\text{C}$ .

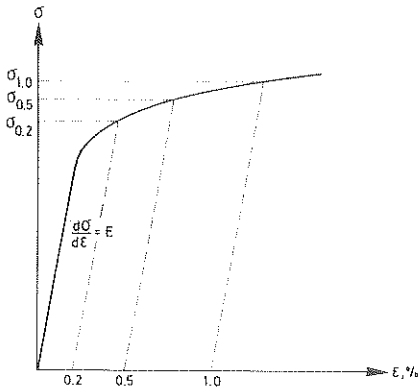

Fig 11 The principal for determining the proof stress, which is based on the residual stress induced strain

### 3.1 TENSILE STRENGTH

a) Structural steel : ASTM A36,  $f_{0.2,20^{\circ}\text{C}} = 300 \text{ MPa}$   
 $f_{u,20^{\circ}\text{C}} = 440 \text{ MPa}$

Test conditions : Steady state  
: Strain rate control  
 $\dot{\epsilon} = 72 \cdot 10^{-3} \cdot \text{min}^{-1}$

Specimen :  $\varnothing = 5.2 \text{ mm}$ ,  $l = 23 \text{ mm}$

Chem. composition : C P S Mn Si  
0.19 0.007 0.03 0.71 0.09

Remarks : Ultimate strength and 0.2% proof stress as function of temperature

Reference : Harmathy & Stanzak (1970)

Fig 1

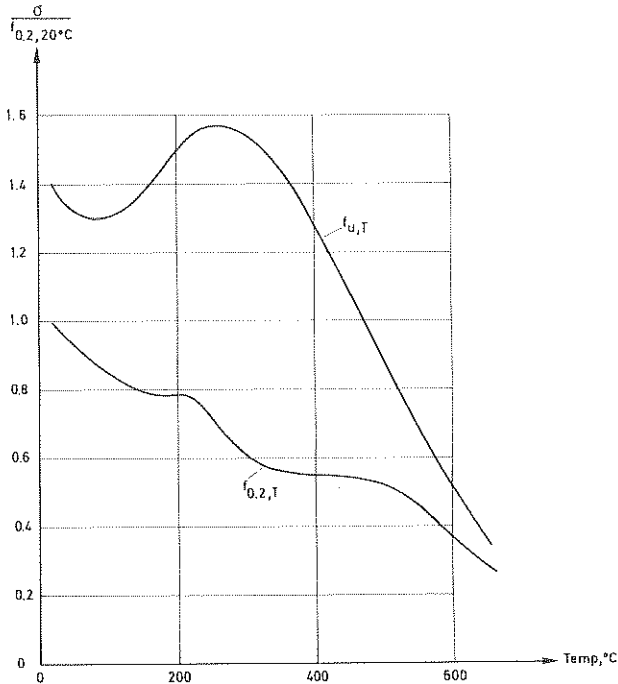

### 3.1 TENSILE STRENGTH

a) Structural steel : CSA G40.12,  $f_{0.2,20^{\circ}\text{C}} = 340 \text{ MPa}$

$f_{u,20^{\circ}\text{C}} = 520 \text{ MPa}$

Steady state

Test conditions : Strain rate control  
 $\dot{\epsilon} = 51-76 \cdot 10^{-3} \cdot \text{min}^{-1}$

Specimen :  $\varnothing = 5.2 \text{ mm}$ ,  $l = 23 \text{ mm}$

Chem. composition	C	P	S	Mn	Si	Cu
	0.195	0.015	0.019	1.40	0.022	0.08
	Ni	Cr				
	0.03	0.01				

Remarks : Ultimate strength and 0.2% proof stress as function of temperature

Reference : Harmathy & Stanzak (1970)

Fig 2

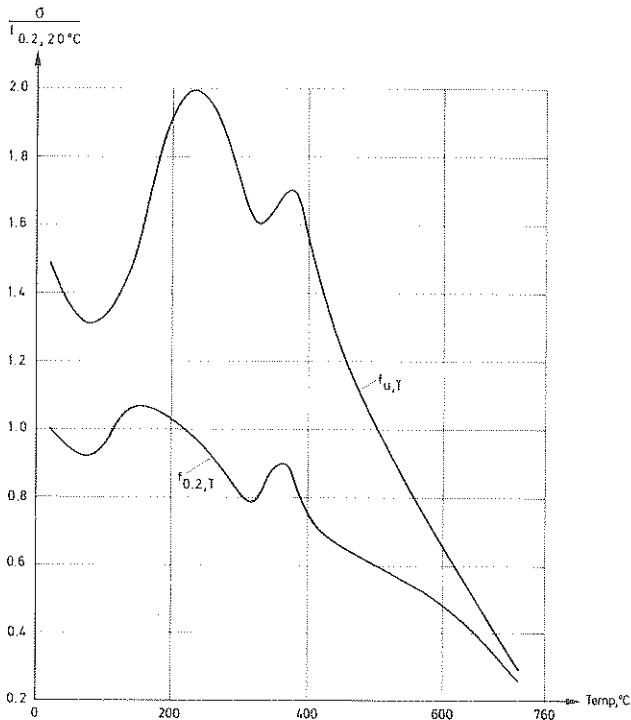

### 3.1 TENSILE STRENGTH

a) Structural steel : Different kinds

Test conditions : Steady state  
Strain rate control,  $\dot{\epsilon} = 16.7 \cdot 10^{-3} \cdot \text{min}^{-1}$

Specimen :  $\phi = 6.3 \text{ mm}$ ,  $l = 57 \text{ mm}$

Chem. composition :

Remarks : 0.2% proof stress for  
different kinds of steel as function  
of temperature

Reference : Teesside Laboratories (1980)

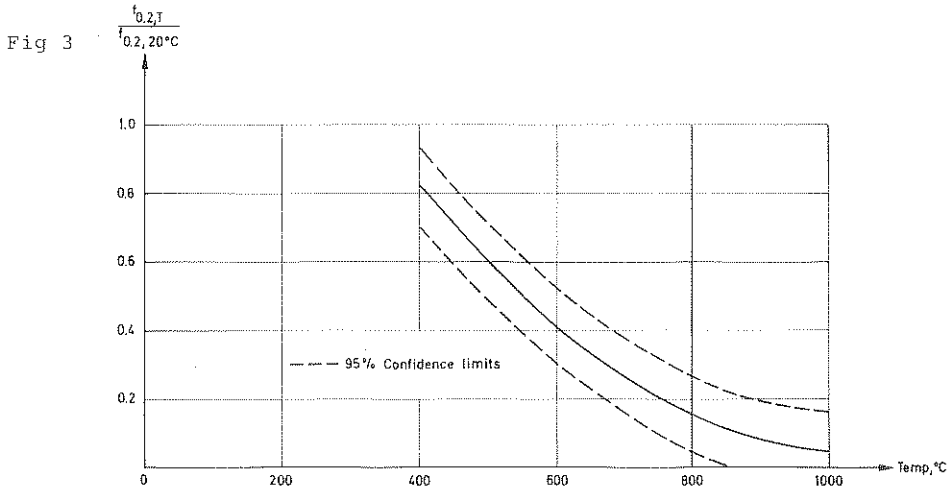



### 3.1 TENSILE STRENGTH

a) Structural steel : Steel 37,  $f_{0.2, 20^{\circ}\text{C}} = 250 \text{ MPa}$

Test conditions : Steady state  
Strain rate control,  $\dot{\epsilon} = 2 \cdot 10^{-3} \cdot \text{min}^{-1}$

Specimen :  $\phi = 7.2 \text{ mm}$ ,  $l = 71 \text{ mm}$

Chem. composition : C P S Mn Si Cr  
0.27 0.033 0.041 0.65 0.128 0.16  
Ni  
0.086

Remarks : Proof stress related to  
different stress induced strains

Reference : Skinner, D.H. (May 1972)

Fig 4

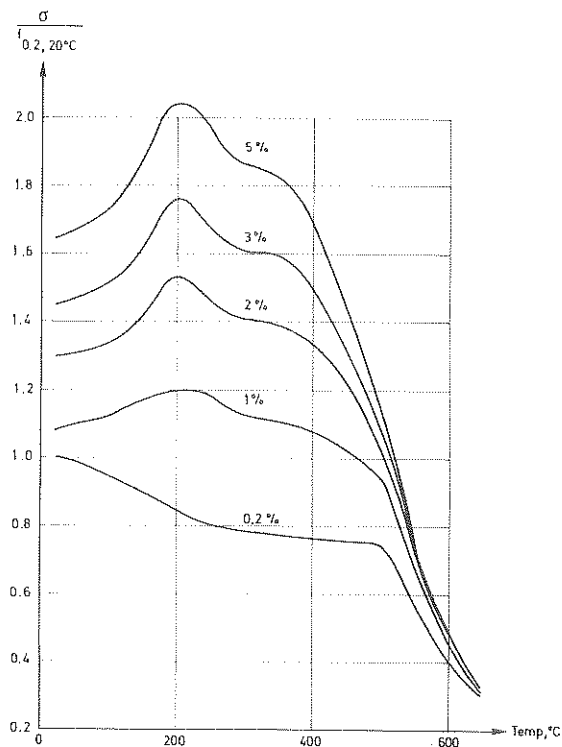

### 3.1 TENSILE STRENGTH

- a) Structural steel : ① St 60/90,  $f_{0.2,20^{\circ}\text{C}} = 590 \text{ MPa}$   
c) Prestressing steel : ② St 145/165,  $f_{0.2,20^{\circ}\text{C}} = 1520 \text{ MPa}$   
                          ③ St 160...180,  $f_{0.2,20^{\circ}\text{C}} = 1570 \text{ MPa}$

Test conditions : Steady state  
                          Stress rate control,  $\dot{\sigma}$  is unknown

Specimen : ① Hot-rolled,  $\phi = 26 \text{ mm}$   
                  ② Cold-drawn,  $\phi = 5.2 \text{ mm}$   
                  ③ Cold-drawn,  $\phi = 5 \text{ mm}$

Chem. composition :

Remarks : 0.2% proof stress as function of temperature

Reference : Dannenberg et al (1959)

Fig 5

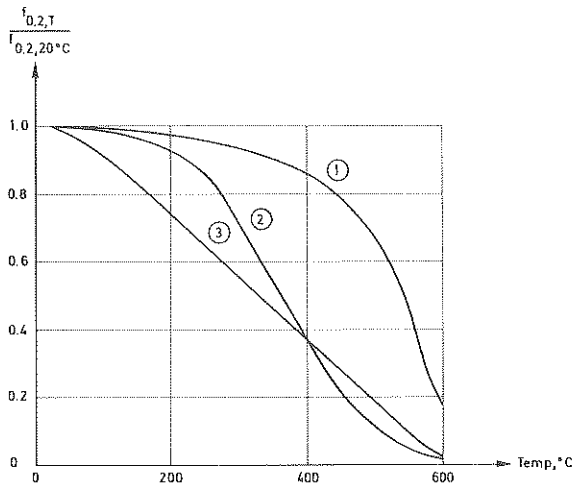

### 3.1 TENSILE STRENGTH

- a) Structural steel : ① St 60/90,  $f_{u,20^{\circ}\text{C}} = 1050$  MPa  
c) Prestressing steel : ② St 145/165,  $f_{u,20^{\circ}\text{C}} = 1650$  MPa  
                          ③ St 160...180,  $f_{u,20^{\circ}\text{C}} = 1740$  MPa

Test conditions : Steady state  
                          Stress rate control,  $\dot{\epsilon}$  is unknown

Specimen : ① Hot-rolled,  $\varnothing = 26$  mm  
                          ② Cold-drawn,  $\varnothing = 5.2$  mm  
                          ③ Cold-drawn,  $\varnothing = 5$  mm

Chem. composition :

Remarks : Ultimate strength (rupture strength)  
                          as function of temperature

Reference : Dannenberg et al (1959)

Fig 6

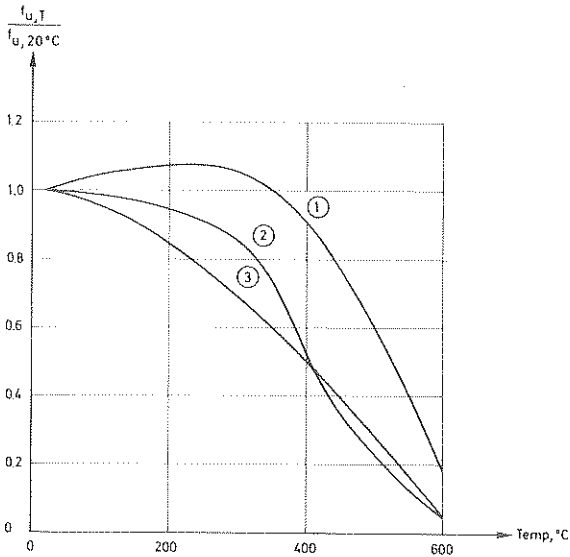

### 3.1 TENSILE STRENGTH

a) Structural steel : Plate steel A36,  $f_{0.2,20^{\circ}\text{C}} = 300 \text{ MPa}$   
Low carbon  $f_{u,20^{\circ}\text{C}} = 440 \text{ MPa}$

Test conditions : Steady state

Specimen :

Chem. composition :

Remarks : Ultimate strength and 0.2% proof stress  
as function of temperature

Reference : Klippstein (1979)

Fig 7

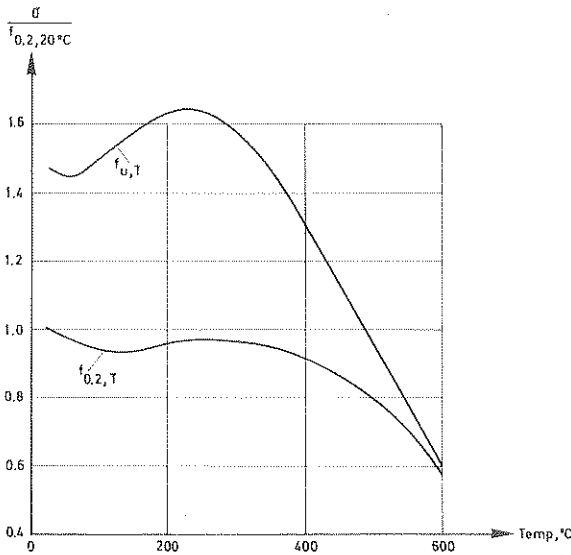

### 3.1 TENSILE STRENGTH

a) Structural steel : Steel 37,  $f_{0.2,20^{\circ}\text{C}} = 250 \text{ MPa}$   
 $f_{u,20^{\circ}\text{C}} = 496 \text{ MPa}$

Test conditions : Steady state  
Strain rate control,  
 $\dot{\epsilon} = 0.1-100 \cdot 10^{-3} \cdot \text{min}^{-1}$

Specimen :  $\phi = 7.2 \text{ mm}$ ,  $\ell = 71 \text{ mm}$

Chem. composition : C P S Mn Si Cr  
Ni  
0.086

Remarks : The influence of strain rate  $\dot{\epsilon}$  on 0.2% proof stress

Reference : Skinner (1972)

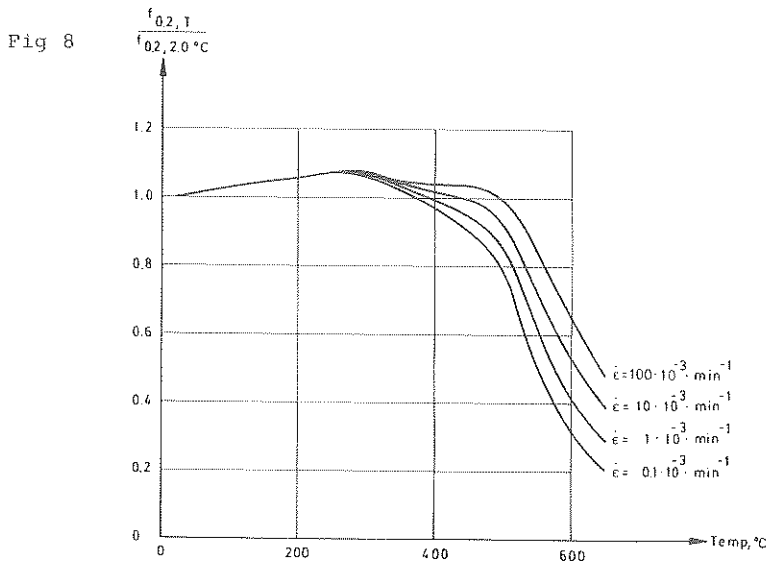

3.1 TENSILE STRENGTH

a) Structural steel : SIS 14 1411,  $f_{0.2,20^{\circ}\text{C}} = 340 \text{ MPa}$

Test conditions : Steady state  
Stress rate control  
①  $\dot{\sigma} = 1.63 \text{ MPa/s}$   
②  $\dot{\sigma} = 0.03 \text{ MPa/s}$

Specimen :  $l = 95 \text{ mm}$ ,  $b = 15 \text{ mm}$ ,  $t = 3 \text{ mm}$

Chem. composition : C P S Mn Si Cr  
Ni  
0.086

Remarks : The influence of rate of loading on  
0.2% proof stress

Reference : Thor, J. (1972)

Fig 9

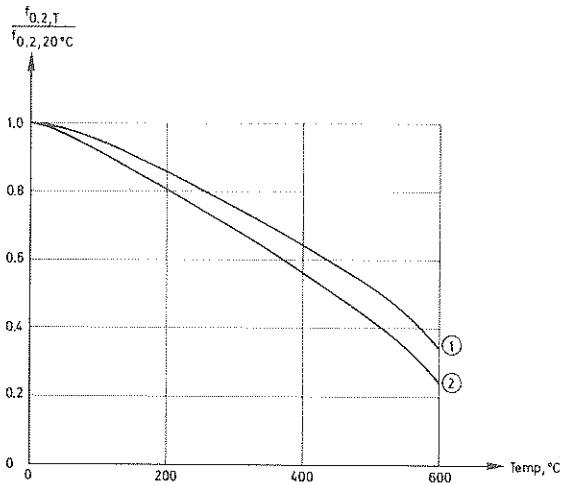

### 3.1 TENSILE STRENGTH

b) Reinforcing steel : Different kinds

Test conditions : Steady state  
Stress rate control,  
 $\dot{\sigma} = 3.5 \text{ MPa/s}$

Specimen :  $\phi = 8-10 \text{ mm}$ ,  $l = 100 \text{ mm}$   
Hot-rolled

Chem. composition :

Remarks : Proof stress related to different  
stress induced strains

Reference : Anderberg (1978)

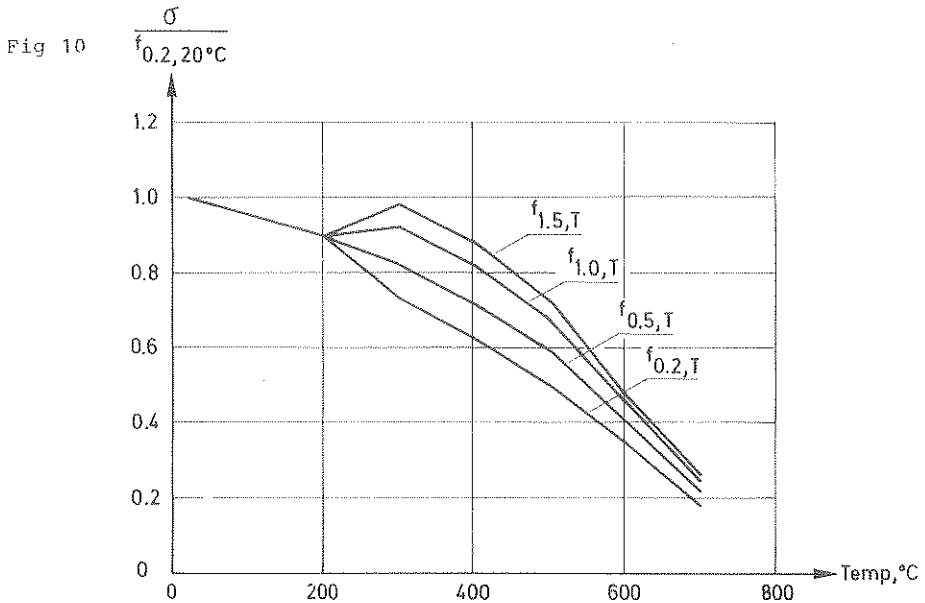

### 3.1 TENSILE STRENGTH

- b) Reinforcing steel : ① BSt 42/50 RU,  $f_{0.2, 20^{\circ}\text{C}} = 430 \text{ MPa}$   
② BSt 42/50 RK,  $f_{0.2, 20^{\circ}\text{C}} = 430 \text{ MPa}$

Test conditions : Transient state with load control  
Rate of heating,  $\dot{T} = 3.8 - 24^{\circ}\text{C/min}$

- Specimen : ① Hot-rolled,  $\phi = 16 \text{ mm}$ ,  $l = 10 \times \phi$   
② Cold-worked,  $\phi = 18 \text{ mm}$ ,  $l = 10 \times \phi$

Chem. composition :

Remarks : Ultimate strength (rupture strength)  
as function of temperature

Reference : Ruge & Winkelmann (1978-80)

Fig 11

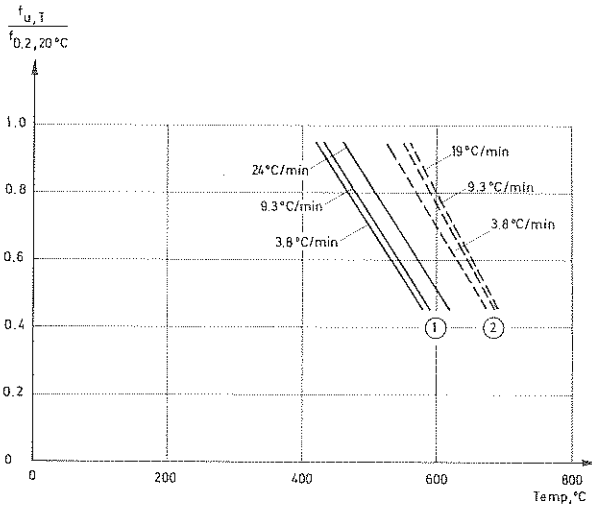



### 3.1 TENSILE STRENGTH

- b) Reinforcing steel : ① BSt 42/50 RU,  $f_{0.2, 20^{\circ}\text{C}} = 430 \text{ MPa}$   
② BSt 42/50 RK,  $f_{0.2, 20^{\circ}\text{C}} = 430 \text{ MPa}$

Test conditions : Transient state with load control  
Rate of heating,  $\dot{T} = 3.8 - 19^{\circ}\text{C}/\text{min}$   
Failure temperature criteria,  $\dot{\epsilon} = 1.0 \cdot 10^{-4} \cdot \text{s}^{-1}$

Specimen : ① Hot-rolled,  $\phi = 16 \text{ mm}$ ,  $l = 10 \times \phi$   
② Cold-worked,  $\phi = 18 \text{ mm}$ ,  $l = 10 \times \phi$

Chem. composition :

Remarks : Ultimate strength as function of temperature, related to the strain rate  
 $\dot{\epsilon} = 1.0 \cdot 10^{-4} \cdot \text{s}^{-1}$

Reference : Ruge & Winkelmann (1978-80)

Fig 12

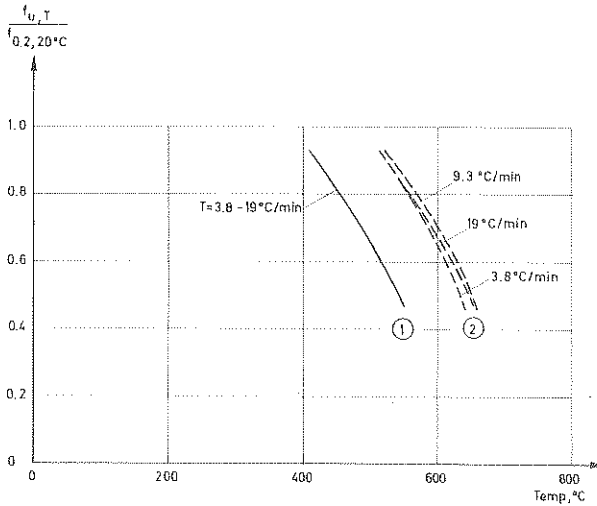

### 3.1 TENSILE STRENGTH

c) Prestressing steel :  $f_{0.2, 20^{\circ}\text{C}} = 1559 \text{ MPa}$   
 $f_{u, 20^{\circ}\text{C}} = 1848 \text{ MPa}$

Test conditions : Steady state  
Strain rate control,  $\dot{\epsilon}$  is unknown  
 $t_s = 10 \text{ min}$

Specimen :  $\varnothing = 4.5 \text{ mm}$

Chem. composition :

Remarks : Ultimate strength and 0.2% proof stress  
as function of temperature

Reference : Voves, B. (1978)

Fig 13

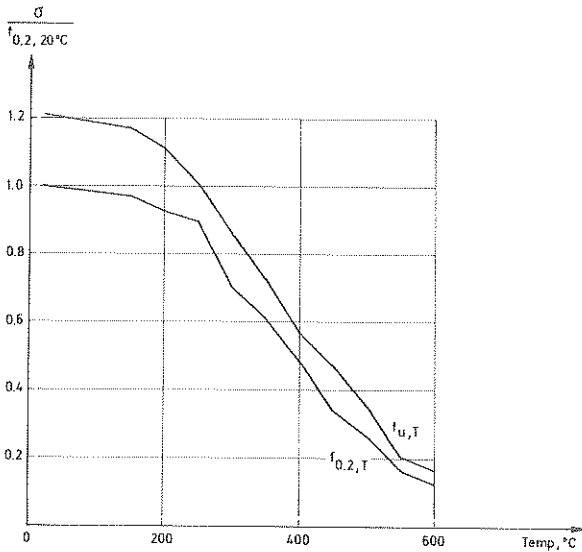

### 3.1 TENSILE STRENGTH

c) Prestressing steel : 87 E 35,  $f_{u,20^{\circ}\text{C}} = 1700 \text{ MPa}$   
Fagersta steel,  $f_{u,20^{\circ}\text{C}} = 1900 \text{ MPa}$

Test conditions : Steady state  
Strain rate control,  
 $\dot{\epsilon} = 75 \cdot 10^{-3} \cdot \text{min}^{-1}$

Specimen :  $\varnothing = 4.3 \text{ mm}$ ,  $l = 200 \text{ mm}$

Chem. composition :

Remarks : Ultimate strength as function of temperature

Reference : Anderberg (1983)

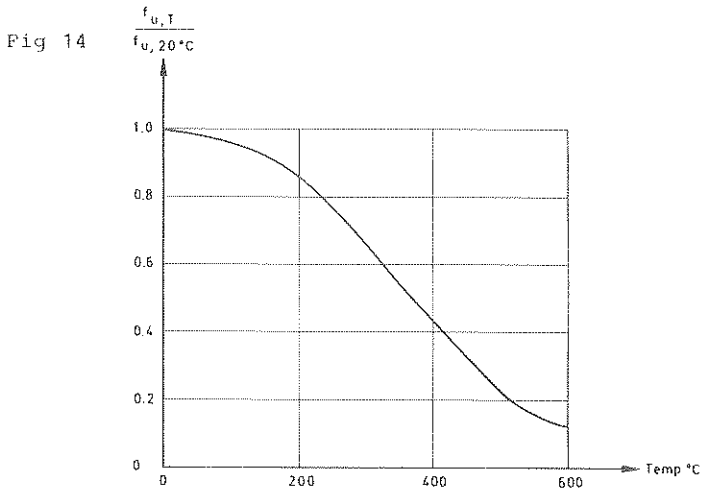

### 3.1 TENSILE STRENGTH

c) Prestressing steel : ASTM A 421,  $f_{0.2,20^{\circ}\text{C}} = 1470 \text{ MPa}$   
 $f_{u,20^{\circ}\text{C}} = 1720 \text{ MPa}$

Test conditions : Steady state  
: Strain rate control  
 $\dot{\epsilon} = 19\text{-}29 \cdot 10^{-3} \cdot \text{min}^{-1}$

Specimen :  $\phi = 4.4 \text{ mm}$ ,  $l = 23 \text{ mm}$

Chem. composition : 

	C	P	S	Mn	Si
	0.749	0.012	0.031	0.78	0.187

Remarks : Ultimate strength and 0.2% proof stress as function of temperature

Reference : Harmathy & Stanzak (1970)

Fig 15

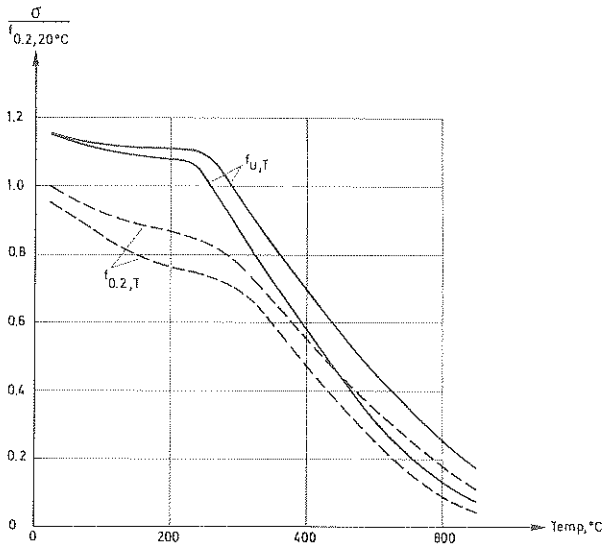

### 3.1 TENSILE STRENGTH

c) Prestressing steel :  $f_{0.2,20^{\circ}\text{C}} = 1070 \text{ MPa}$   
 $f_{u,20^{\circ}\text{C}} = 1630 \text{ MPa}$

Test conditions : Steady state

Specimen :

Chem. composition	C	P	S	Mn	Si
	0.78	0.024	0.022	0.63	0.21

Remarks : Ultimate strength and 0.2% proof stress as function of temperature

Reference : Cahill (1965)

Fig 16

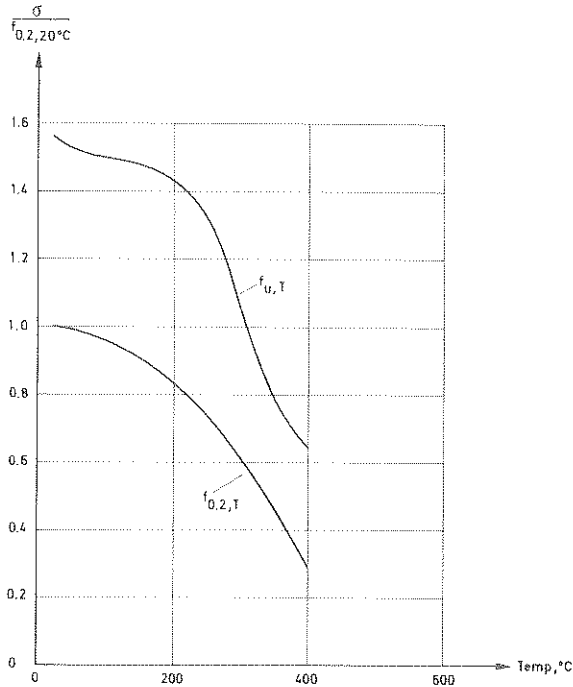

### 3.1 TENSILE STRENGTH

c) Prestressing steel :  $f_{0.2, 20^{\circ}\text{C}} = 1559 \text{ MPa}$   
 $f_{u, 20^{\circ}\text{C}} = 1848 \text{ MPa}$

Test conditions : Transient state with load control  
Rate of heating,  $\dot{T} = 12^{\circ}\text{C}/\text{min}$

Specimen :  $\varnothing = 4.5 \text{ mm}$

Chem. composition :

Remarks : Ultimate strength (rupture strength)  
as function of temperature

Reference : Voves, B. (1978)

Fig 17

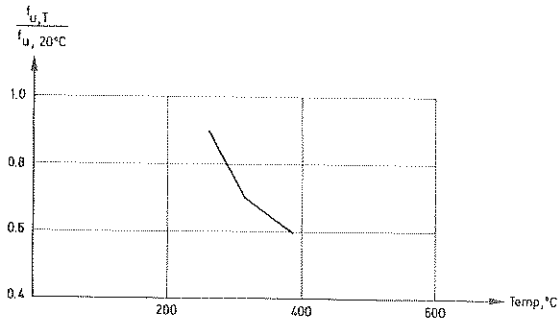

### 3.1 TENSILE STRENGTH

c) Prestressing steel : St 1570/1770, 1  $f_{0.2,20^{\circ}\text{C}} = 1570 \text{ MPa}$

2  $f_{u,20^{\circ}\text{C}} = 1660 \text{ MPa}$

Test conditions : Transient state with load control  
Rate of heating,  $\dot{T} = 4^{\circ}\text{C}/\text{min}$   
Failure temperature criteria,  
 $\dot{\epsilon} = 1.0 \cdot 10^{-4} \cdot \text{s}^{-1}$

Specimen : ① Cold-worked,  $\phi = 7.5 \text{ mm}$   
② " " ,  $\phi = 5.0 \text{ mm}$   
 $\ell = 10 \times \phi$

Chem. composition : Ultimate strength as function of temperature, related to the strain rate  
 $\dot{\epsilon} = 1.0 \cdot 10^{-4} \cdot \text{s}^{-1}$

Remarks :

Reference : Ruge & Winkelmann (1978-80)

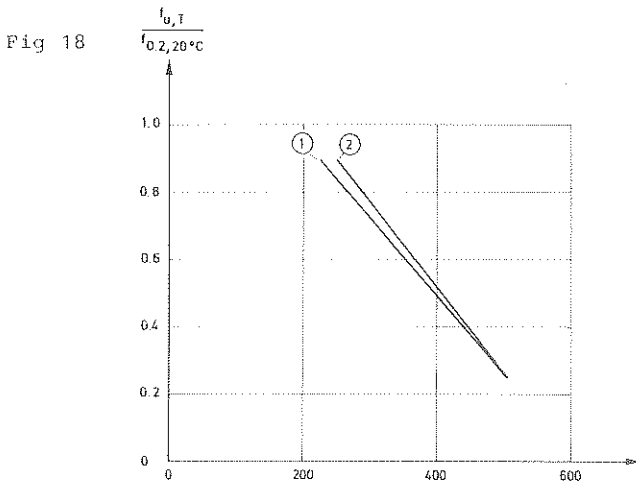

### 3.1 TENSILE STRENGTH

a) Prestressing steel : PTV  $f_{u,20^{\circ}\text{C}} = 1750$  MPa  
LTP " = 1550 MPa  
LTR " = 1550 MPa  
PTS " = 1700 MPa

Test conditions : Transient state with load control  
Rate of heating,  $\dot{T}$  is unknown

Specimen :

Chem. composition :

Remarks : Ultimate strength (rupture strength)  
as function of temperature

Reference : Baus, Brenneisen & Langueville (1968)

Fig 19

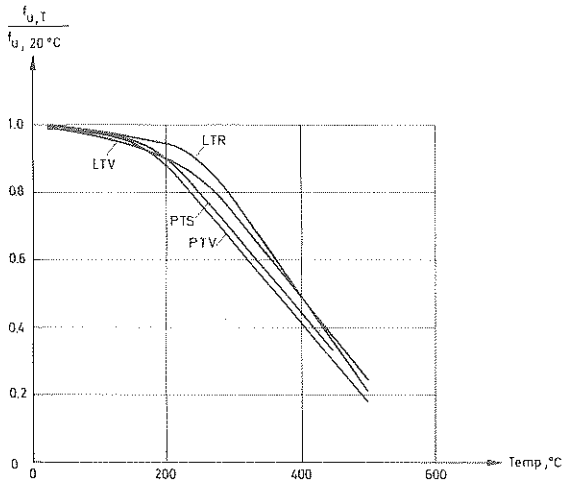



### 3.2 Modulus of elasticity

The variation of the modulus of elasticity with time,  $E_T$ , can be directly obtained from  $\sigma$ - $\epsilon$  relationships as the initial inclination of the curve. If the  $\sigma$ - $\epsilon$  relationships include creep strains the value of  $E_T$  will be somewhat decreased. The test conditions are therefore of importance, when comparing results from different sources. If  $E_T$  is determined in a dynamic test the result can also differ. If  $E_T$  is obtained from constructed  $\sigma$ - $\epsilon$  curves which are related to transient tests (see chapter 3.5.2) the influence of creep cannot be avoided.

The modulus of elasticity decreases with temperature and at 500-550°C the value is about  $0.5 \cdot E_{20^\circ\text{C}}$ . The original strength characteristics seems to have little influence on  $E_T$ . Essential results are summarized in Fig 1-7.

### 3.2 MODULUS OF ELASTICITY

a) Structural steel : Plate steel A36,  $f_{0.2,20^{\circ}\text{C}} = 300 \text{ MPa}$   
Low carbon  $f_{u,20^{\circ}\text{C}} = 440 \text{ MPa}$

Test conditions : Steady state

Specimen :

Chem. composition :

Remarks : Modulus of elasticity

Reference : Klippstein (1979)

Fig 1

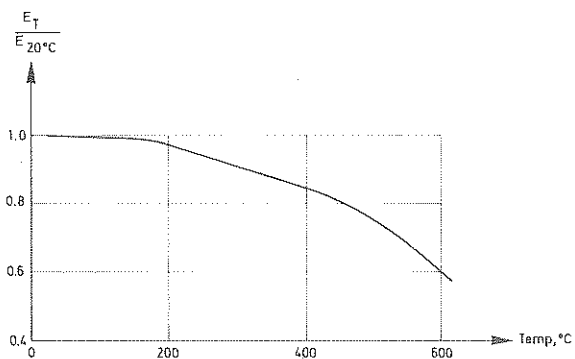

### 3.2 MODULUS OF ELASTICITY

a) Structural steel : Various steels

Test conditions :

Specimen :

Chem. composition :

Remarks : Modulus of elasticity

Reference : Stirland (1980)  
Teesside Laboratories

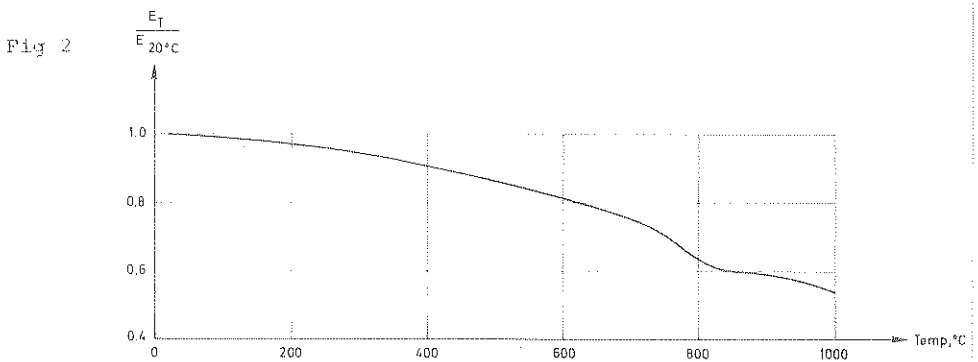

### 3.2 MODULUS OF ELASTICITY

a) Structural steel : Carbon steels

Test conditions : Steady state

Specimen :

Chem. composition :

Remarks : Modulus of elasticity (mean curve from three sources: Garofalo (1950), Lea et al (1914), Versé (1935))

Reference : Harmathy (1967)

Fig 3

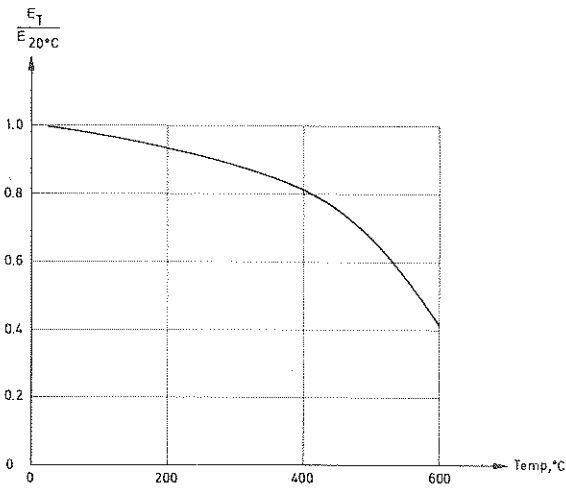

### 3.2 MODULUS OF ELASTICITY

a) Structural steel :

Test conditions : Steady state  
Stress rate control,  $\dot{\sigma} = 1.63 \text{ MPa/s}$

Specimen :

Chem. composition :

Remarks : Modulus of elasticity

Reference : Thor, J. (1972)

Fig 4

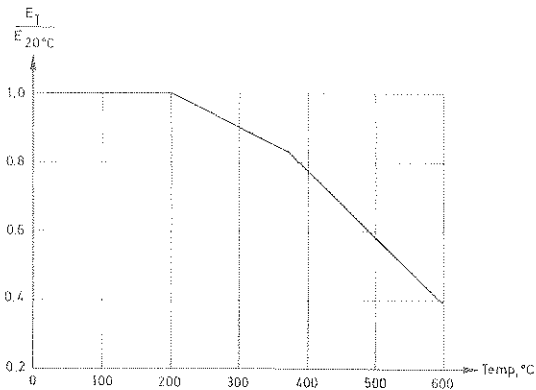

### 3.2 MODULUS OF ELASTICITY

a) Structural steel : Fe E 24,  $f_{0.2, 20^{\circ}\text{C}} = 270 \text{ MPa}$

Test conditions : Transient state  
Constant load control  
Rate of heating,  $\dot{T} = 10^{\circ}\text{C}/\text{min}$

Specimen :

Chem. composition :

Remarks : Modulus of elasticity

Reference : Copier, W.J. (1972)

Fig 5

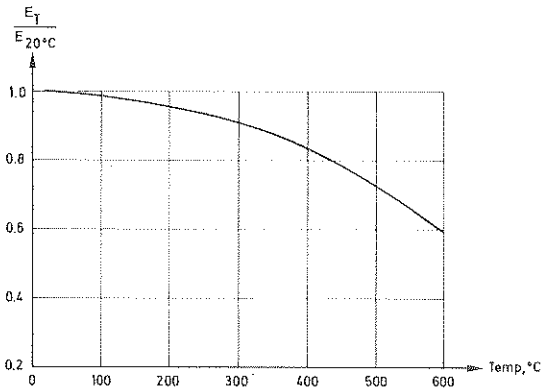

### 3.2 MODULUS OF ELASTICITY

b) Reinforcing steel : Different kinds, Ks 40, Ks 60

Test conditions : Steady state  
Stress rate control,  $\dot{\sigma} = 3.5 \text{ MPa/s}$

Specimen : Hot-rolled,  $\phi 8-10$ ,  $l = 100 \text{ mm}$

Chem. composition :

Remarks : Modulus of elasticity (mean curve)

Reference : Anderberg (1978)

Fig 6

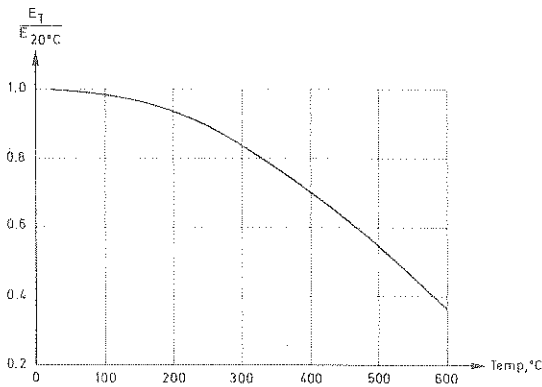

### 3.2 MODULUS OF ELASTICITY

c) Prestressing steel : St 1570/1770,  $E_{20^{\circ}\text{C}} = 2.14 \cdot 10^5$  MPa

Test conditions : Steady state  
Rate of stress,  $\dot{\sigma}$  is unknown

Specimen : Cold-worked,  $\phi = 7.5$  mm

Chem. composition :

Remarks : Modulus of elasticity

Reference : Ruge & Winkelmann (1978-80)

Fig 7

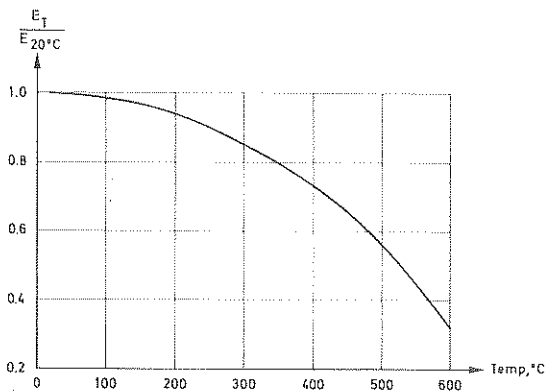



### 3.3 Thermal strain

The thermal strain or thermal expansion is measured on unloaded specimens in a transient test. Investigations published in literature indicate small deviations for structural and prestressing steels. Type of steel and strength characteristics seem to have no significant influence. In Fig 1 the thermal strain for structural steel is taken from four different sources. The curves are relatively close together. For reinforcing steels there is only one source of information available which indicates lower thermal strain than other steels as shown in Fig 2. In this figure the results from a prestressing steel are also indicated.

### 3.3 THERMAL STRAIN

Fig 1 Thermal strain (expansion) for structural steel as function of temperature

- ① St 37-2, Ruge & Winkelmann (1978-80)
- ② Steel 37, Skinner (1972)
- ③ A 36, Harmathy (1967)
- ④ Stirland (1980)

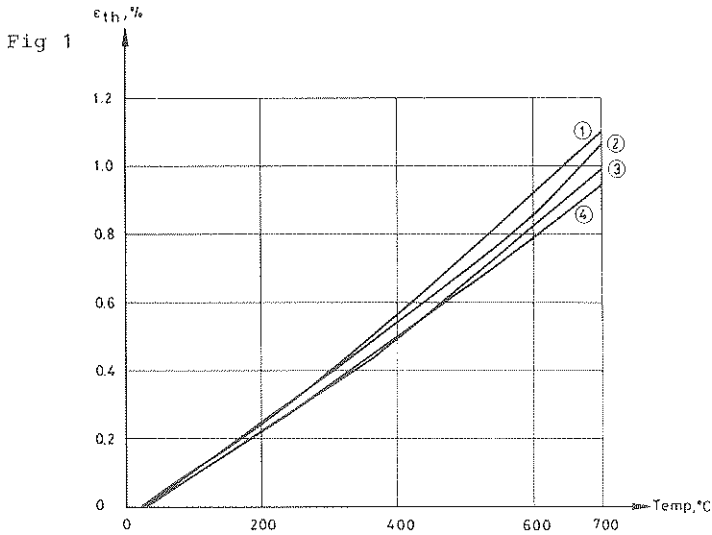

### 3.3 THERMAL STRAIN

Fig 2 Thermal strain (expansion) for ① reinforcing and ② prestressing steel as function of temperature

① Anderberg (1978)

② Ruge & Winkelmann (1978-80)

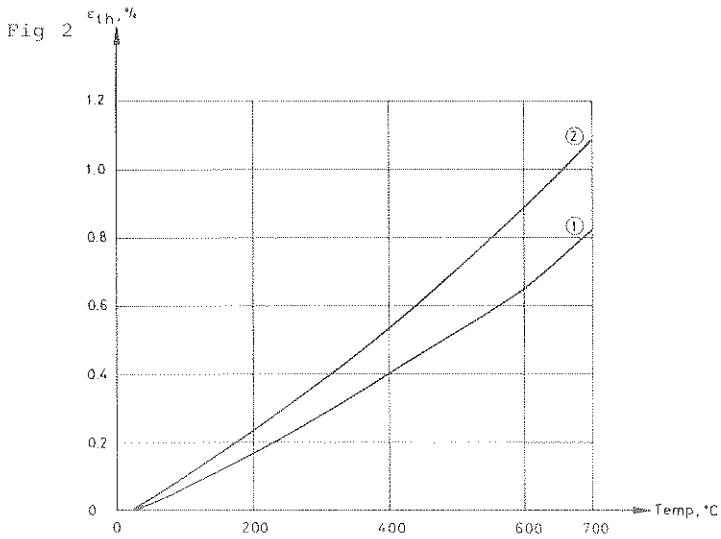

### 3.4 Creep strain

Creep behaviour is unique for every type of steel and a common description is hard to find. This is due to the fact that the chemical composition and the degree of processing strongly influences this. The creep tendency seems not to be related to the 0.2% proof stress or other strength characteristics at room temperature. Therefore the absolute value of stress is used when describing creep analytically. Analytical creep models will be presented in chapter 5. The creep starts to be of importance at about 250°C for cold-worked steel and at about 400°C for hot-rolled steel.

The creep strain can only be directly measured in steady state tests and if the stress is kept constant it can be separated into two phases as illustrated in Fig 6. However, the creep from steady state tests can be used in order to predict the creep process in transient tests, which is illustrated in chapter 5.

Measurements on creep at high temperatures are very complicated and the accuracy and reliability of the testing equipment are of decisive importance for the results. In Fig 5 creep results are shown from two identical tests on specimens from the same heat. The creep strain after 1.5 h indicates a difference of about 20%. If the specimens are not from the same heat deviation may rise to 40%. The scatter in the results are not only due to the testing equipment but also to the difference in shape and processing of the specimen.

Some results on creep published in literature are illustrated in Fig 1-5. More results for analytical studies are given in chapter 5.

### 3.4 CREEP STRAIN

a) Structural steel : Al 149,  $f_{0.2, 20^{\circ}\text{C}} = 250 \text{ MPa}$   
X-60,  $f_{0.2, 20^{\circ}\text{C}} = 450 \text{ MPa}$

Test conditions : Steady state  
Constant load control

Specimen :

Chem. composition :

Remarks : Creep at  $500^{\circ}\text{C}$  for different load levels

Reference : Knight et al (1971)

Fig 1

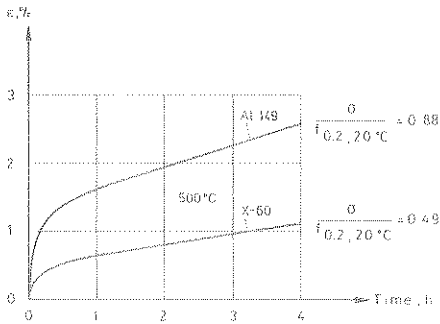

### 3.4 CREEP STRAIN

a) Structural steel : Steel 37,  $f_{0.2,20^{\circ}\text{C}} = 250 \text{ MPa}$   
 $f_{u,20^{\circ}\text{C}} = 496 \text{ MPa}$

Test conditions : Steady state  
Constant load control

Specimen :  $\varnothing = 7.2 \text{ mm}$ ,  $l = 71 \text{ mm}$

Chem. composition : C P S Mn Si Cr  
Ni  
0.086

Remarks : Creep at  $550^{\circ}\text{C}$  for different load levels

Reference : Skinner (1972)

Fig 2

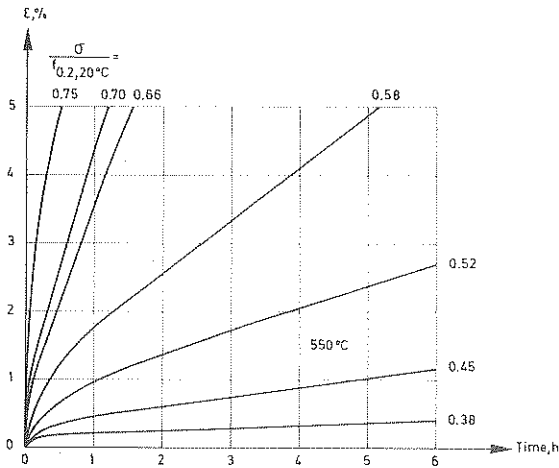

### 3.4 CREEP STRAIN

b) Reinforcing steel : Ks 40,  $f_{0.2,20^{\circ}\text{C}} = 456 \text{ MPa}$   
                               : Ks 60,  $f_{0.2,20^{\circ}\text{C}} = 710 \text{ MPa}$

Test conditions : Steady state  
                               Constant load control

Specimen :  $\varnothing = 8 \text{ mm}$ ,  $l = 100 \text{ mm}$   
                               Hot-rolled

Chem. composition : C      P      S      Mn    Si  
                               : 0.41  0.029  0.039  0.66  0.27

Remarks : Creep at about  $600^{\circ}\text{C}$  for different  
                               load levels

Reference : Anderberg (1978)

Fig 3

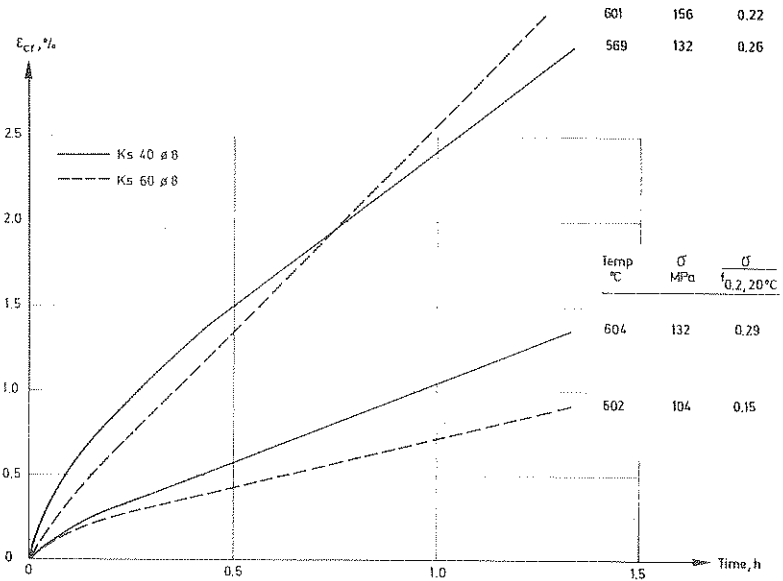

### 3.4 CREEP STRAIN

b) Reinforcing steel : Ks 40, different kinds

Test conditions : Steady state  
Constant load control

Specimen :  $\varnothing = 8\text{mm}$ ,  $l = 100\text{ mm}$   
Hot-rolled

Chem. composition :

Remarks : Creep at about  $650^{\circ}\text{C}$  for  
different hot-rolled steels

Reference : Anderberg (1978)

Fig 4

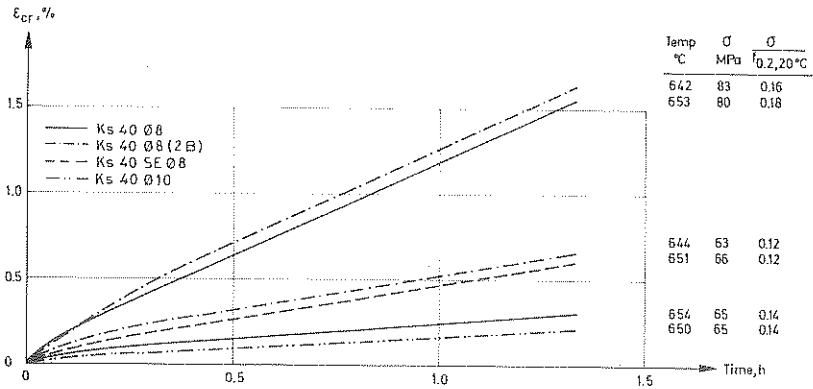



### 3.4 CREEP STRAIN

b) Reinforcing steel : Ks 40,  $f_{0.2,20^{\circ}\text{C}} = 483 \text{ MPa}$

Test conditions : Steady state  
Constant load control

Specimen :  $\varnothing = 10 \text{ mm}$ ,  $l = 100 \text{ mm}$   
Hot-rolled

Chem. composition : C P S Mn Si  
: 0.31 0.024 0.021 0.75 0.27

Remarks : Deviation in results in two  
creep tests with specimens from  
the same heat

Fig 5

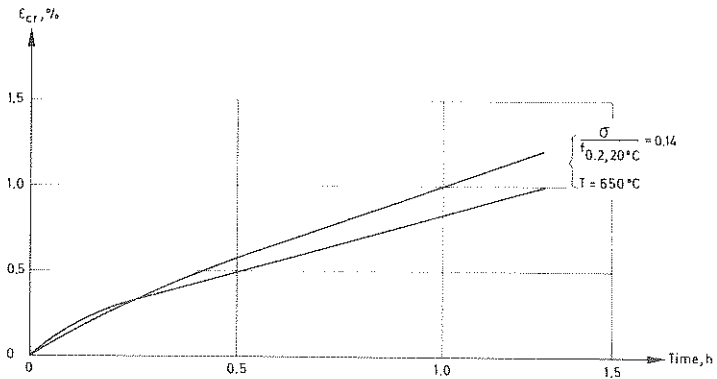

### 3.5 Stress-strain characteristics

The data presented are divided into two categories, namely steady state and transient state properties. A survey of the most important properties related to the test procedure is given.

#### 3.5.1 Steady state data

$\sigma$ - $\epsilon$  relationships obtained under strain rate or stress rate control are illustrated in eighteen (18) diagrams for the three types of steel: structural, reinforcing and prestressing steel. All curves are drawn dimensionless and are related to  $f_{0.2,20^{\circ}\text{C}}$ .

The stress-strain relationship is often obtained at a high rate of stress or a high rate of strain (test duration period less than 1-2 min for structural and reinforcing steel and less than 1/2 min for prestressing steel) in order to avoid the influence of creep which is of importance above about 250 and 400 $^{\circ}\text{C}$  for hot-rolled and cold-worked steels, respectively. At these higher temperatures a slow stress rate or strain rate (test duration period is more than about 1 h for structural and reinforcing steel and more than about 5 min for prestressing steel) considerably influence the amount of creep observed. This results in a displaced  $\sigma$ - $\epsilon$  curve and a lower ultimate strength.

It can be generally stated for hot-rolled steel that the ultimate strength (maximum point in the  $\sigma$ - $\epsilon$  curve) at 500 and 600 $^{\circ}\text{C}$  decreases to about 0.8 and 0.5 of  $f_{0.2,20^{\circ}\text{C}}$ , respectively, if the test duration period is short (high rate of stress or strain). For prestressing steel the comparative values are about 0.45 and 0.25 of  $f_{0.2,20^{\circ}\text{C}}$ .

Some comparisons have also shown that steels that are not cold-worked have very similar dimensionless  $\sigma$ - $\epsilon$  relationships at elevated temperatures.

In the presented test results the strain rate,  $\dot{\epsilon}$ , has been varied from 2 to  $200 \cdot 10^{-3} \cdot \text{min}^{-1}$  for structural steel and from 25 to  $700 \cdot 10^{-3} \cdot \text{min}^{-1}$  for prestressing steel. This means a variation of the test duration period from about 1 h to 1 min and from about 6 min to 20 s, respectively. The influence of  $\dot{\epsilon}$  can be separately studied in Figs 7 and 17.

The stress rate,  $\dot{\sigma}$ , has been varied from 0.03 to 3.5 MPa/s, which means a variation of the test duration period from about 2.5 h to 15 s. The influence of  $\dot{\sigma}$  is illustrated in Figs 10, 11 and 13.

It can be generally noticed that the maximum decrease of ultimate strength due to creep effects amounts to about 15% of  $f_{0.2, 20^\circ\text{C}}$  at 550-600°C except for prestressing steel.

3.5.1 STEADY STATE DATA

a) Structural steel : CSA G40.12,  $f_{0.2,20^{\circ}\text{C}} = 340 \text{ MPa}$

Test conditions : Strain rate control  
 $\dot{\epsilon} = 51-76 \cdot 10^{-3} \cdot \text{min}^{-1}$

Specimen :  $\phi = 5.2 \text{ mm}$ ,  $l = 23 \text{ mm}$

Chem. composition : C P S Mn Si Cu  
0.195 0.015 0.019 1.40 0.022 0.08  
N Cr  
0.03 0.01

Remarks :  $\sigma$ - $\epsilon$  relationships

Reference : Harmathy & Stanzak (1970)

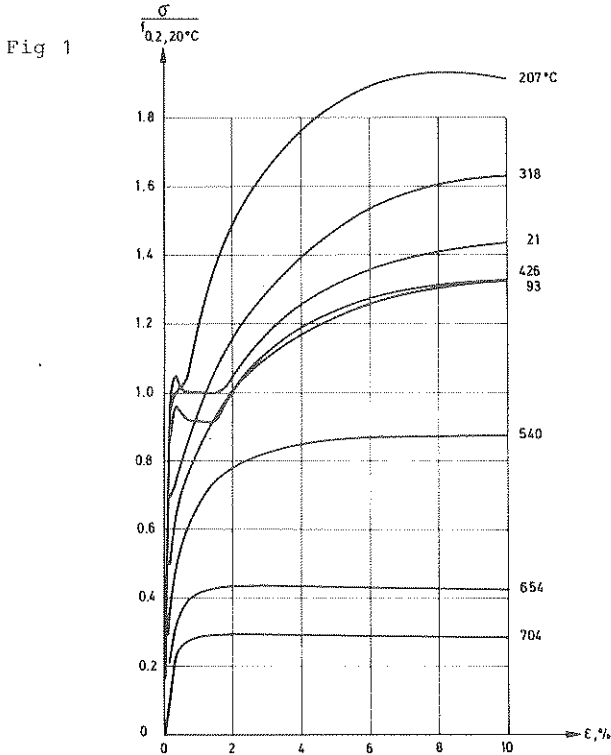

3.5.1 STEADY STATE DATA

a) Structural steel : ASTM A36,  $f_{0.2,20^{\circ}\text{C}} = 300 \text{ MPa}$

Test conditions : Strain rate control  
 $\dot{\epsilon} = 72-102 \cdot 10^{-3} \cdot \text{min}^{-1}$

Specimen :  $\varnothing = 5.2 \text{ mm}$ ,  $l = 23 \text{ mm}$

Chem. composition : C P S Mn Si  
0.19 0.007 0.03 0.71 0.09

Remarks :  $\sigma$ - $\epsilon$  relationships

Reference : Harmathy & Stanzak (1970)

Fig 2

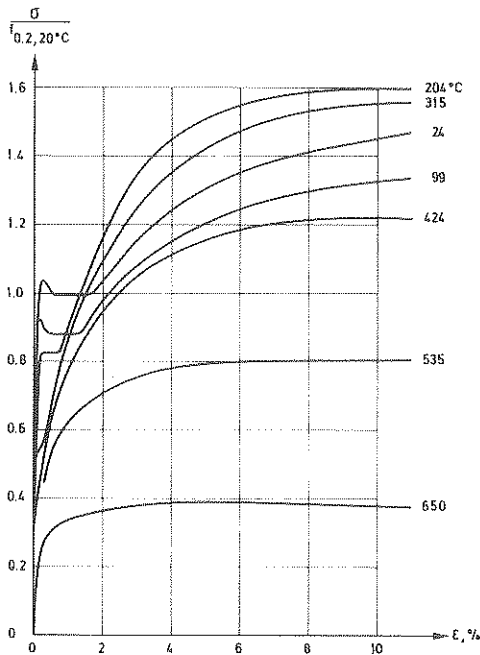

3.5.1 STEADY STATE DATA

a) Structural steel : Grade 43A,  $f_{0.2,20^{\circ}\text{C}} = 260 \text{ MPa}$

Test Conditions : Strain rate control,  $\dot{\epsilon} = 17 \cdot 10^{-3} \cdot \text{min}^{-1}$

Specimen :  $\varnothing = 6.3 \text{ mm}$ ,  $l = 57 \text{ mm}$

Chem. composition :

Remarks :  $\sigma$ - $\epsilon$  relationships

Reference : Teesside Laboratories (1980)

Fig 3

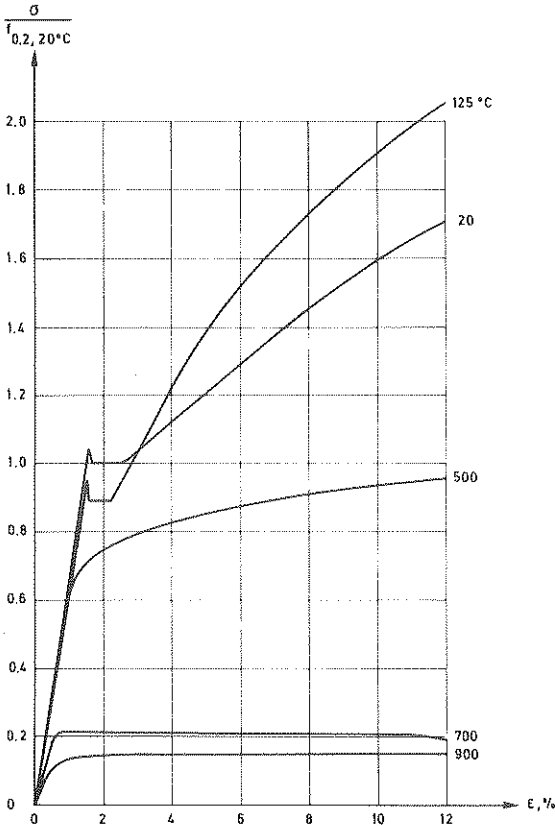

3.5.1 STEADY STATE DATA

a) Structural steel : Steel 37,  $f_{0.2,20^{\circ}\text{C}} = 253 \text{ MPa}$

Test conditions : Strain rate control  
 $\dot{\epsilon} = 2 \cdot 10^{-3} \cdot \text{min}^{-1}$

Specimen :  $\varnothing = 7.2 \text{ mm}$ ,  $l = 71 \text{ mm}$

Chem. composition : C P S Mn Si Cr  
0.27 0.033 0.041 0.65 0.128 0.16  
Ni  
0.086

Remarks :  $\sigma$ - $\epsilon$  relationships

Reference : Skinner (1972)

Fig 4

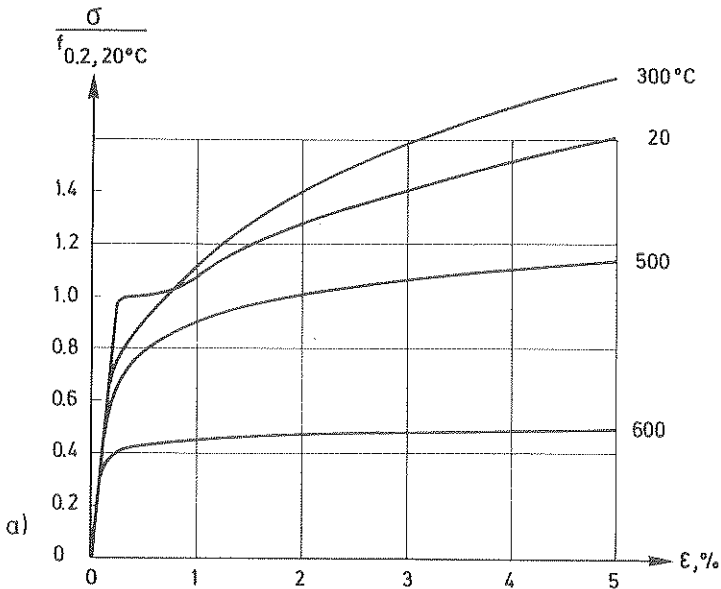

3.5.1 STEADY STATE DATA

a) Structural steel : ,  $f_{0.2, 20^{\circ}\text{C}} = 265 \text{ MPa}$

Test conditions : Strain rate control  
 $\dot{\epsilon} = 5 \cdot 10^{-3} \cdot \text{min}^{-1}$

Specimen :  $\varnothing = 8 \text{ mm}$ ,  $l = 100 \text{ mm}$

Chem. composition :

Remarks :  $\sigma$ - $\epsilon$  relationships

Reference : Jörgensen et al (1980)

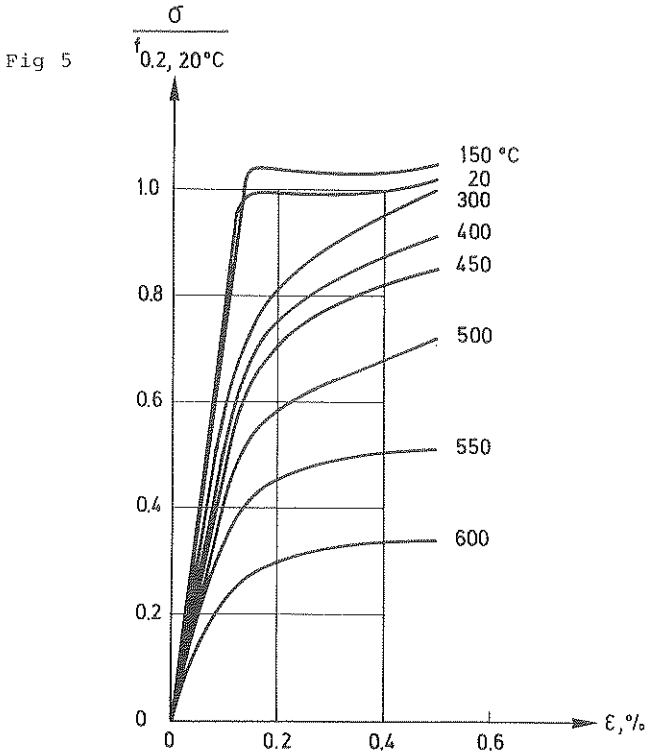



3.5.1 STEADY STATE DATA

a) Structural steel :  $f_{0.2, 20^{\circ}\text{C}} = 265 \text{ MPa}$

Test conditions : Strain rate control  
 $\dot{\epsilon} = 200 \cdot 10^{-3} \cdot \text{min}^{-1}$

Specimen :  $\phi = 8 \text{ mm}, l = 100 \text{ mm}$

Chem. composition :

Remarks :  $\sigma$ - $\epsilon$  relationships

Reference : Jörgensen et al (1980)

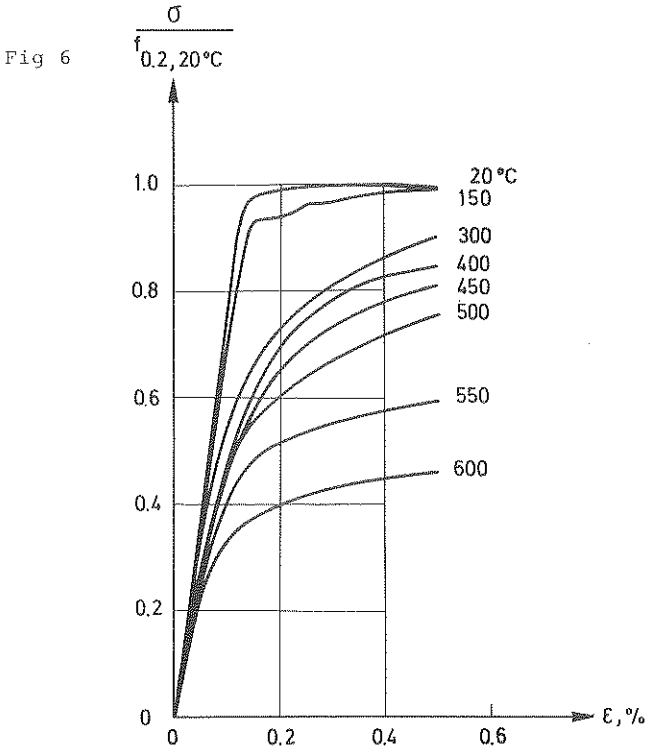

3.5.1 STEADY STATE DATA

a) Structural steel :  $f_{0.2, 20^{\circ}\text{C}} = 265 \text{ MPa}$

Test conditions : Strain rate control  
①  $\dot{\epsilon} = 200 \cdot 10^{-3} \cdot \text{min}^{-1}$   
②  $\dot{\epsilon} = 5 \cdot 10^{-3} \cdot \text{min}^{-1}$

Specimen :  $\phi = 8 \text{ mm}, \ell = 100 \text{ mm}$

Chem. composition :

Remarks : Influence of strain rate on  $\sigma$ - $\epsilon$  relationship att  $550^{\circ}\text{C}$  and  $600^{\circ}\text{C}$

Reference : Jörgensen et al (1980)

Fig 7

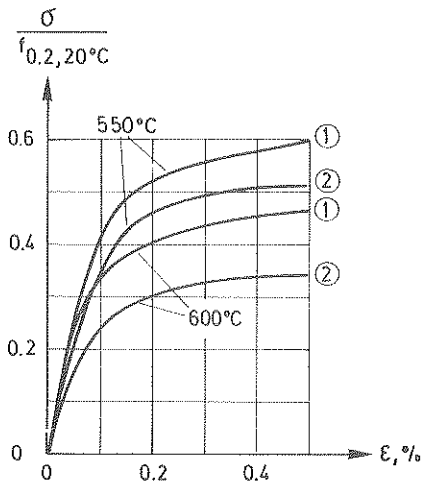

3.5.1 STEADY STATE DATA

a) Structural steel : SIS 141411,  $f_{0.2,20^{\circ}\text{C}} = 340 \text{ MPa}$

Test conditions : Stress rate control,  $\dot{\sigma} = 1.63 \text{ MPa/s}$

Specimen :  $l = 95 \text{ mm}$ ,  $b = 15 \text{ mm}$  and  $t = 3 \text{ mm}$

Chem. composition :

Remarks :  $\sigma$ - $\epsilon$  relationships

Reference : Thor, J. (1972)

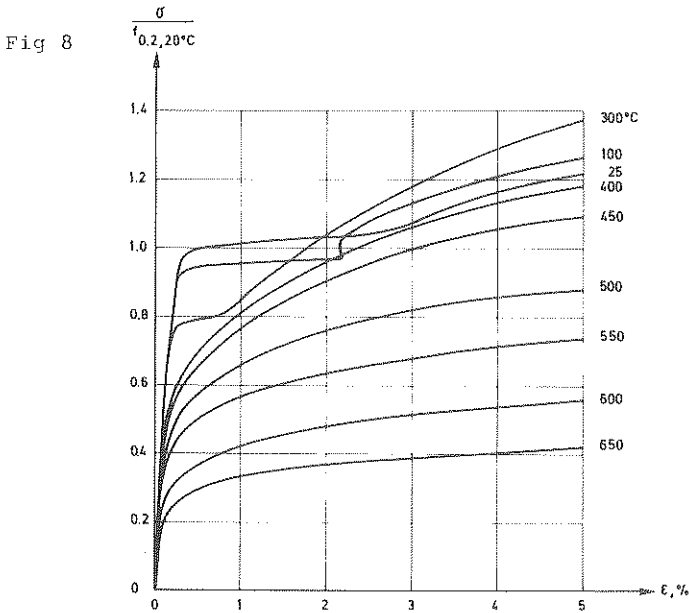

3.5.1 STEADY STATE DATA

a) Structural steel : SIS 141411,  $f_{0.2,20^{\circ}\text{C}} = 340 \text{ MPa}$

Test conditions : Stress rate control,  $\dot{\sigma} = 0.03 \text{ MPa/s}$

Specimen :  $l = 95 \text{ mm}$ ,  $b = 15 \text{ mm}$  and  $t = 3 \text{ mm}$

Chem. composition :

Remarks :  $\sigma$ - $\epsilon$  relationships

Reference : Thor, J. (1972)

Fig 9

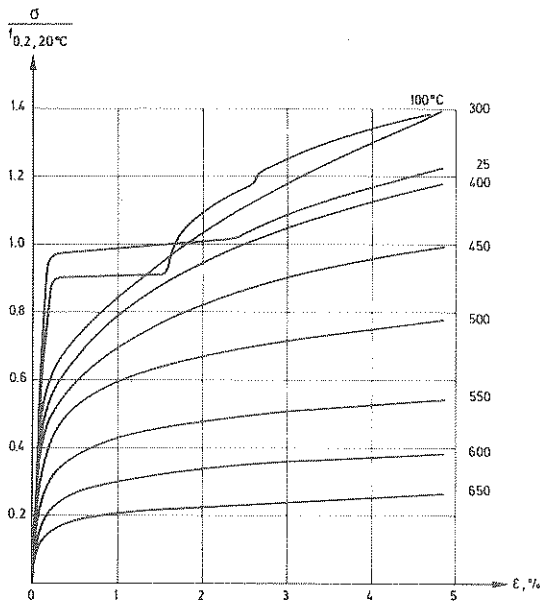

3.5.1 STEADY STATE DATA

a) Structural steel : SIS 141411,  $f_{0.2,20^{\circ}\text{C}} = 340 \text{ MPa}$

Test conditions : Stress rate control  
①  $\dot{\sigma} = 1.61 \text{ MPa/s}$   
②  $\dot{\sigma} = 0.32 \text{ MPa/s}$   
③  $\dot{\sigma} = 0.03 \text{ MPa/s}$

Specimen :  $l = 95 \text{ mm}$ ,  $b = 15 \text{ mm}$  and  $t = 3 \text{ mm}$

Chem. composition:

Remarks : Influence of stress rate on  $\sigma$ - $\epsilon$  relationship at  $550^{\circ}\text{C}$

Reference : Thor, J. (1972)

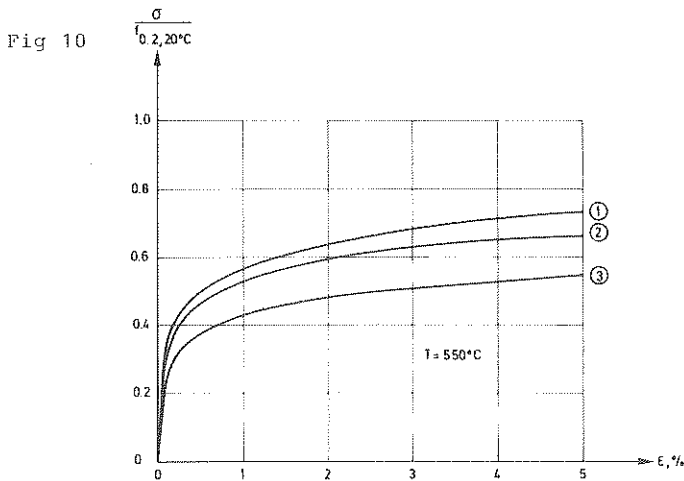

3.5.1 STEADY STATE DATA

a) Structural steel : SIS 141411,  $f_{0.2,20^{\circ}\text{C}} = 340 \text{ MPa}$

Test conditions : Stress rate control  
①  $\dot{\sigma} = 1.62 \text{ MPa/s}$   
②  $\dot{\sigma} = 0.32 \text{ MPa/s}$   
③  $\dot{\sigma} = 0.03 \text{ MPa/s}$

Specimen :  $l = 95 \text{ mm}$ ,  $b = 15 \text{ mm}$  and  $t = 3 \text{ mm}$

Chem. composition :

Remarks : Influence of stress rate on  $\sigma$ - $\epsilon$  relationship at  $600^{\circ}\text{C}$

Reference : Thor, J. (1972)

Fig 11

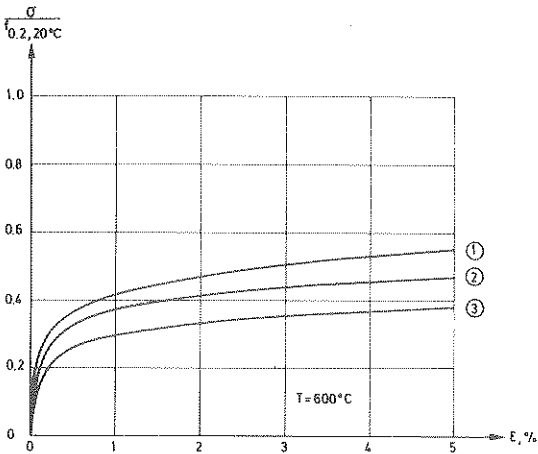

3.5.1 STEADY STATE DATA

b) Reinforcing steel : Different kinds

Test conditions : Stress rate control,  $\dot{\sigma}=3.5$  MPa/s

Specimen :  $\phi = 8-10$  mm,  $l = 100$  mm  
Hot-rolled

Chem. composition :

Remarks :  $\sigma$ - $\epsilon$  relationships

Reference : Anderberg (1978)

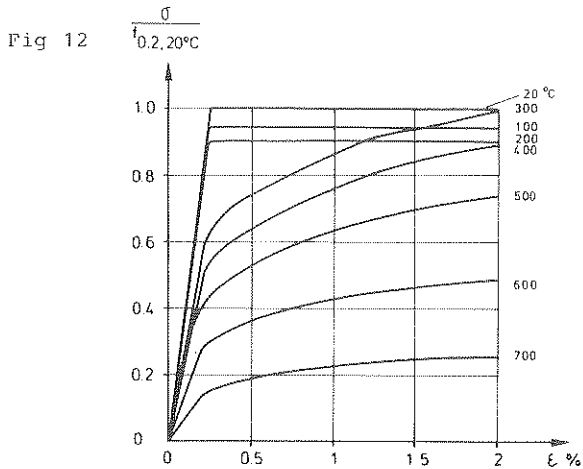

### 3.5.1 STEADY STATE DATA

b) Reinforcing steel : Different kinds

Test conditions : Stress rate control  
 $\dot{\sigma} = 3.5$  and  $0.07$  MPa/s

Specimen :  $\phi = 8-10$  mm,  $l = 100$  mm  
Hot-rolled

Chem. composition :

Remarks : Influence of stress rate on  $\sigma$ - $\epsilon$  relationship at different temperatures

Reference : Anderberg (1978)

Fig 13

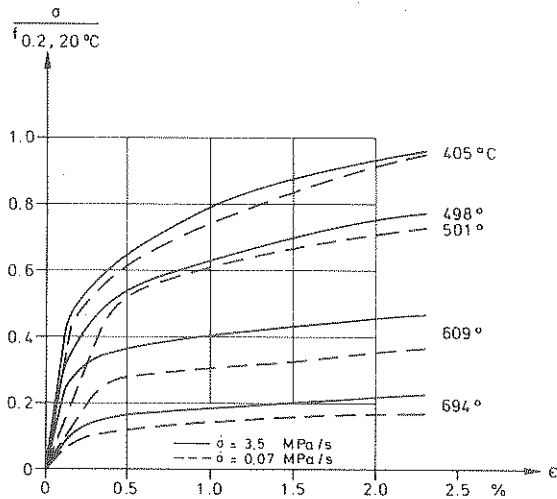



3.5.1 STEADY STATE DATA

c) Prestressing steel : ASTM A421,  $f_{0.2,20^{\circ}\text{C}} = 1470 \text{ MPa}$   
 $f_{u,20^{\circ}\text{C}} = 1720 \text{ MPa}$

Test conditions : Strain rate control  
 $\dot{\epsilon} = 19-29 \cdot 10^{-3} \cdot \text{min}^{-1}$

Specimen :  $\phi = 4.4 \text{ mm}$ ,  $l = 23 \text{ mm}$

Chem. composition : C P S Mn Si  
0.749 0.012 0.031 0.78 0.187

Remarks :  $\sigma$ - $\epsilon$  relationships

Reference : Harmathy & Stanzak (1970)

Fig 14

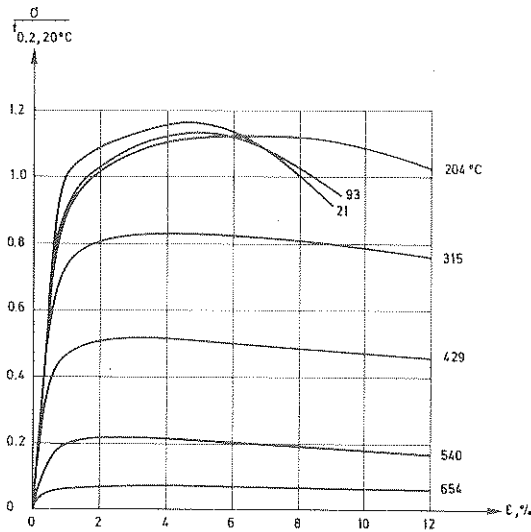

3.5.1 STEADY STATE DATA

c) Prestressing steel : ASTM A421,  $f_{0.2,20^{\circ}\text{C}} = 1470 \text{ MPa}$   
 $f_{u,20^{\circ}\text{C}} = 1720 \text{ MPa}$

Test conditions : Strain rate control  
 $\dot{\epsilon} = 56-98 \cdot 10^{-3} \cdot \text{min}^{-1}$

Specimen :  $\varnothing = 4.4 \text{ mm}$ ,  $\ell = 23 \text{ mm}$

Chem. composition : C P S Mn Si  
0.794 0.012 0.031 0.78 0.187

Remarks :  $\sigma$ - $\epsilon$  relationships

Reference : Harmathy & Stanzak (1970)

Fig 15

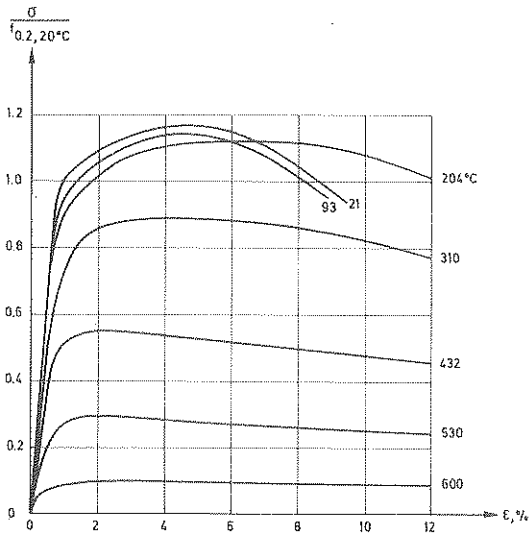

### 3.5.1 STEADY STATE DATA

c) Prestressing steel : ASTM A421,  $f_{0.2,20^{\circ}\text{C}} = 1470 \text{ MPa}$   
 $f_{u,20^{\circ}\text{C}} = 1720 \text{ MPa}$

Test conditions : Strain rate control  
 $\dot{\epsilon} = 370-700 \cdot 10^{-3} \cdot \text{min}^{-1}$

Specimen :  $\varnothing = 4.4 \text{ mm}$ ,  $l = 23 \text{ mm}$

Chem. composition : C P S Mn Si  
0.794 0.012 0.031 0.78 0.187

Remarks :  $\sigma$ - $\epsilon$  relationships

Reference : Harmathy & Stanzak (1970)

Fig 16

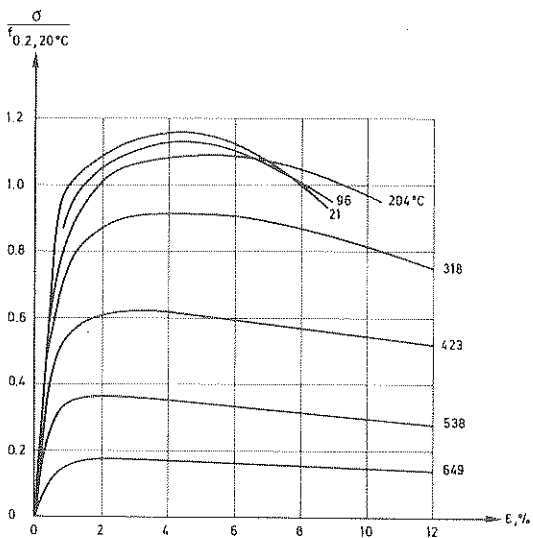

### 3.5.1 STEADY STATE DATA

c) Prestressing steel : ASTM A421,  $f_{0.2,20^{\circ}\text{C}} = 1470 \text{ MPa}$   
 $f_{u,20^{\circ}\text{C}} = 1720 \text{ MPa}$

Test conditions : Strain rate control  
①  $\dot{\epsilon} = 550 \cdot 10^{-3} \cdot \text{min}^{-1}$   
②  $\dot{\epsilon} = 80 \cdot 10^{-3} \cdot \text{min}^{-1}$   
③  $\dot{\epsilon} = 25 \cdot 10^{-3} \cdot \text{min}^{-1}$

Specimen :  $\phi = 4.4 \text{ mm}$ ,  $l = 23 \text{ mm}$

Chem. composition : C 0.749 P 0.012 S 0.031 Mn 0.78 Si 0.187

Remarks : Influence of strain rate on  $\sigma$ - $\epsilon$  relationship at  $430^{\circ}\text{C}$  and  $540^{\circ}\text{C}$

Reference : Harmathy & Stanzak (1970)

Fig 17

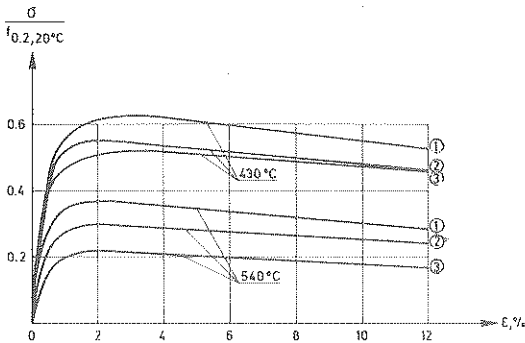

3.5.1 STEADY STATE DATA

c) Prestressing steel :  $f_{0.2, 20^{\circ}\text{C}} = 1559 \text{ MPa}$   
 $f_{u, 20^{\circ}\text{C}} = 1848 \text{ MPa}$

Test conditions : Steady state  
Strain rate control,  $\dot{\epsilon}$  is unknown  
 $t_s = 10 \text{ min}$

Specimen :  $\phi = 4.5 \text{ mm}$

Chem. composition :

Remarks :  $\sigma$ - $\epsilon$  relationships

Reference : Voves, B. (1978)

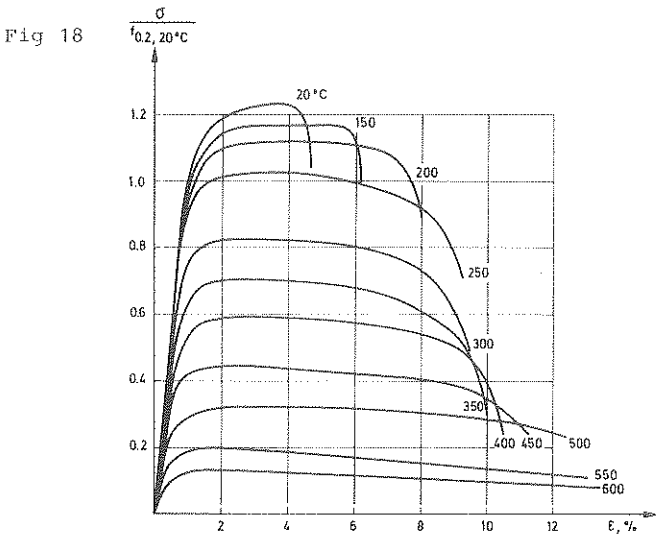

### 3.5.2 Transient state data

In this chapter two kinds of data will be presented namely deformation as function of temperature and constructed  $\sigma$ - $\epsilon$  relationships as described in section 2.2.1. The deformation can be total or total deformation minus initial elastic strain and/or thermal strain. Results are presented in fifteen (15) diagrams with constructed  $\sigma$ - $\epsilon$  curves in Figs 6, 7, 8 and 15.

The deformation-temperature curves are very much influenced by the rate of heating,  $\dot{T}$ , and in the presented results it has been varied from 1.7 to 50°C/min. For protected steel the rate of heating is in most cases between 5 and 10°C/min.

Some of the results indicate an instability phase of the steel which suddenly results in increased deformation and give a more or less marked plateau in the diagram, see Figs 1, 3, 9, 12, 13 and 14. This deformation instability occurs at the load level  $0.6-0.9 \cdot f_{0.2, 20}^{\circ\text{C}}$ . How the rate of heating influences this behaviour is not clear.

Due to the rate of heating, the time for the creep to develop is different and this influences the total deformation. As a consequence this also makes the critical temperature dependent on the value of  $\dot{T}$ . By studying the results presented in the diagrams, the following decrease in failure temperature is obtained:

<u>Source</u>	<u><math>T, \text{ }^{\circ}\text{C}/\text{min}</math></u>	<u>Decrease, <math>^{\circ}\text{C}</math></u>
Skinner (1972)	10-1.7	35
Copier (1972)	50-5	40
Ruge & Winkelmann (1978-80)	10-4	20

It may be noted that there are great differences in the deformation curves taken from different sources.

Finally, it can be noticed that in  $\sigma$ - $\epsilon$  curves constructed from transient data a great deal of creep is included. The results for structural steel given in Figs 6 and 7 are in a relatively good agreement.

3.5.2 TRANSIENT STATE DATA

a) Structural steel : FeE 24,  $f_{0.2, 20^{\circ}\text{C}} = 270 \text{ MPa}$

Test conditions : Constant load control  
Rate of heating,  $\dot{T} = 10^{\circ}\text{C}/\text{min}$

Specimen :

Chem. composition :

Remarks : Total deformation minus thermal strain  
as function of temperature at different  
load levels

Reference : Copier, W.J. (1972)

Fig 1

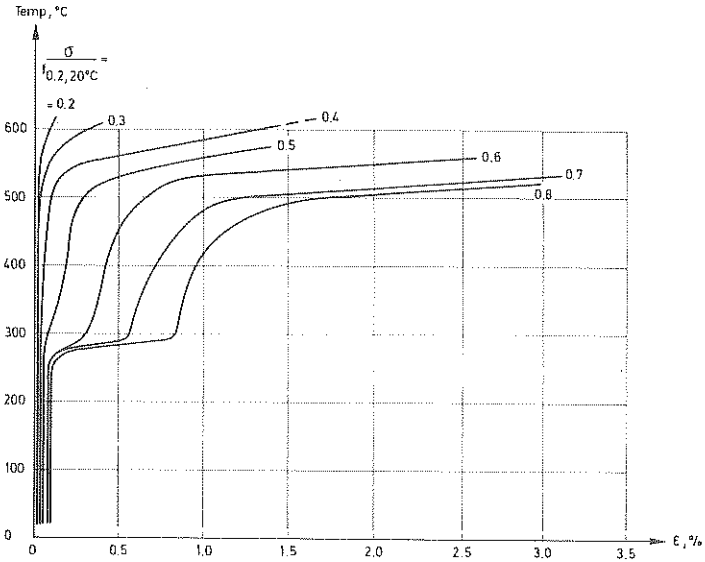

3.5.2 TRANSIENT STATE DATA

a) Structural steel : Fe E24,  $f_{0.2, 20^{\circ}\text{C}} = 270 \text{ MPa}$

Test conditions : Constant load control  
Rate of heating,  $\dot{T} = 5, 10, 50^{\circ}\text{C}/\text{min}$

Specimen :

Chem. composition :

Remarks : Influence of rate of heating on total deformation minus thermal and initial elastic strain as function of temperature at different load levels

Reference : Copier, W.J. (1972)

Fig 2

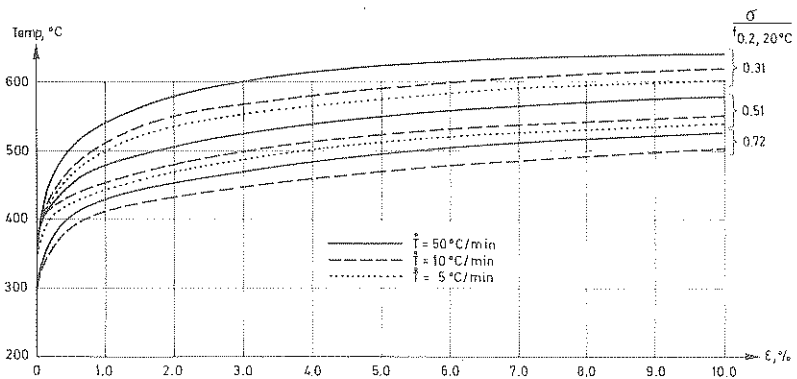



3.5.2 TRANSIENT STATE DATA

a) Structural steel : St 52,  $f_{0.2, 20^{\circ}\text{C}} = 480 \text{ MPa}$

Test conditions : Constant load control  
Rate of heating,  $\dot{T} = 4$  and  $10^{\circ}\text{C}/\text{min}$

Specimen :  $b = 10 \text{ mm}$ ,  $l = 100 \text{ mm}$

Chem. composition :

Remarks : Total deformation minus thermal strain  
and initial elastic strain as function  
of temperature at different load levels

Reference : Ruge & Winkelmann (1978-80)

Fig 3

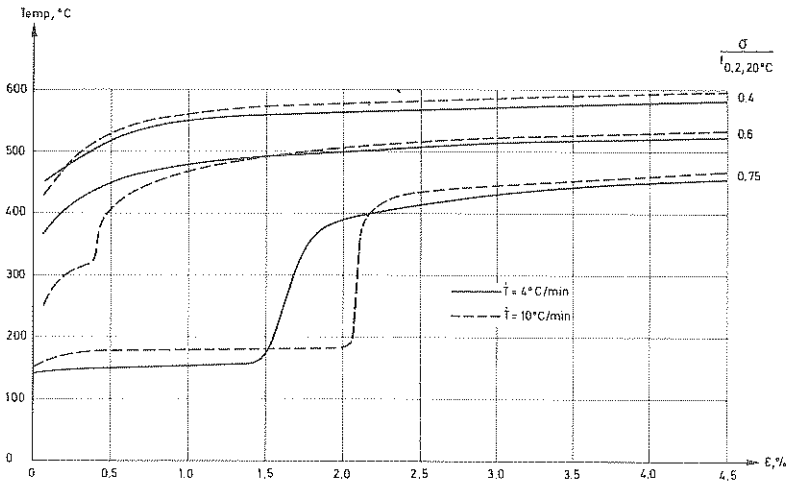

3.5.2 TRANSIENT STATE DATA

a) Structural steel : Steel 37,  $f_{0.2,20^{\circ}\text{C}} = 250 \text{ MPa}$   
 $f_{u,20^{\circ}\text{C}} = 496 \text{ MPa}$

Test conditions : Constant load control  
Rate of heating,  $\dot{T} = 1.7$  and  $10^{\circ}\text{C}/\text{min}$

Specimen :  $\phi = 7.2 \text{ mm}$ ,  $l = 71 \text{ mm}$

Chem. composition : C P S Mn Si Cr  
0.27 0.033 0.041 0.65 0.128 0.16  
Ni  
0.86

Remarks : Total deformation minus thermal and  
initial elastic strain as function of  
temperature at different load levels

Reference : Skinner (1972)

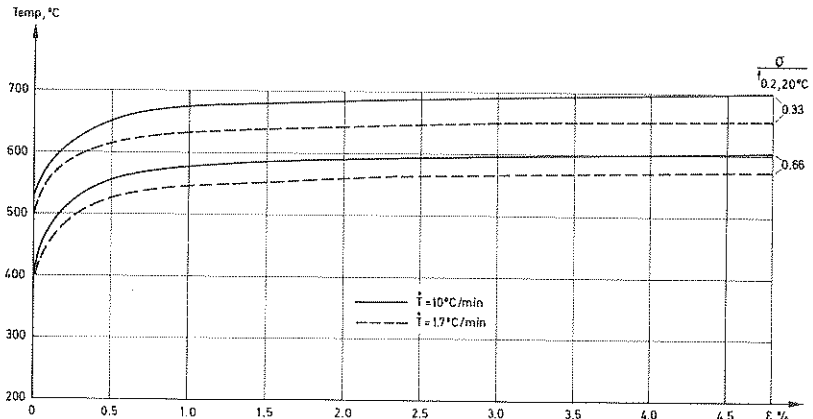

Fig 4

### 3.5.2 TRANSIENT STATE DATA

a) Structural steel : Steel 37,  $f_{0.2,20^{\circ}\text{C}} = 250 \text{ MPa}$   
 $f_{u,20^{\circ}\text{C}} = 496 \text{ MPa}$

Test conditions : Constant load control  
Rate of heating,  $\dot{T} = 1.7 \text{ and } 10^{\circ}\text{C/min}$

Specimen :  $\phi = 7.2 \text{ mm}$ ,  $l = 71 \text{ mm}$

Chem. composition : C 0.27 P 0.033 S 0.041 Mn 0.65 Si 0.128 Cr 0.16  
Ni 0.086

Remarks : Influence of rate of heating on total deformation minus thermal strain as function of temperature at different load levels

Reference : Skinner (1972)

Fig 5

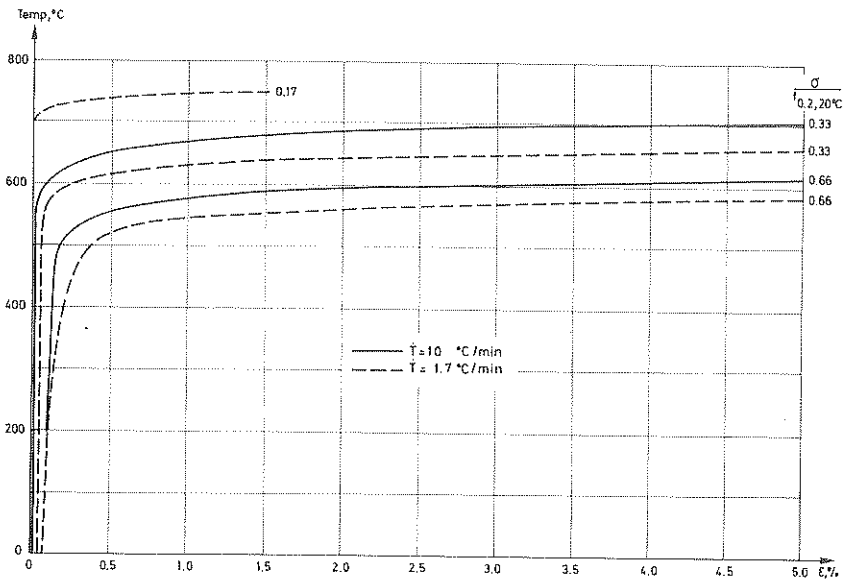

3.5.2 TRANSIENT STATE DATA

a) Structural steel : St 37-2,  $f_{0.2,20^{\circ}\text{C}} = 255 \text{ MPa}$

Test conditions : Constant load control  
Rate of heating,  $\dot{T} = 10^{\circ}\text{C}/\text{min}$

Specimen :  $b = 10 \text{ mm}$ ,  $l = 100 \text{ mm}$

Chem. composition :

Remarks : Constructed  $\sigma$ - $\epsilon$  relationships

Reference : Ruge & Winkelmann (1978-80)

Fig 6

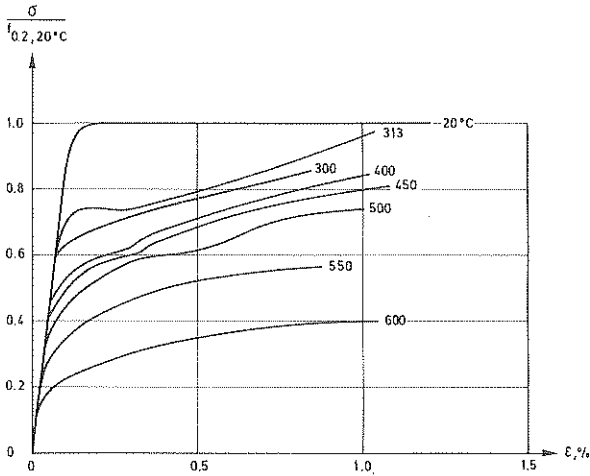

3.5.2 TRANSIENT STATE DATA

a) Structural steel : FeE 24,  $f_{0.2, 20^{\circ}\text{C}} = 270 \text{ MPa}$

Test conditions : Constant load control  
Rate of heating,  $\dot{T} = 10^{\circ}\text{C}/\text{min}$

Specimen :

Chem. composition :

Remarks : Constructed  $\sigma$ - $\epsilon$  relationships

Reference : Copier, W.J. (1972)

Fig 7

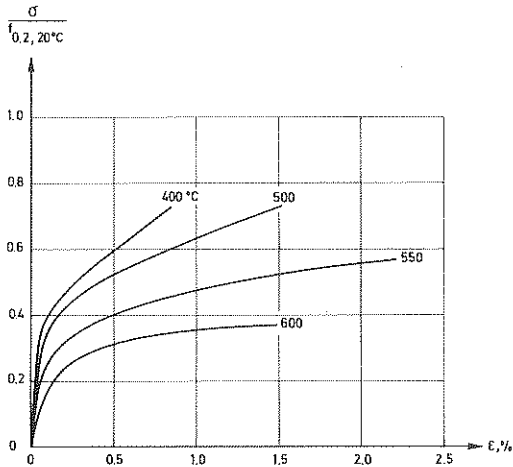

3.5.2 TRANSIENT STATE DATA

a) Structural steel : Fe E24,  $f_{0.2, 20^{\circ}\text{C}} = 270 \text{ MPa}$

Test conditions : Constant load control  
Rate of heating,  $\dot{T} = 10^{\circ}\text{C}/\text{min}$

Specimen :

Chem. composition :

Remarks : Constructed  $\sigma$ - $\epsilon$  relationships for ECCS

Reference : Witteveen, J. et al (1977)

Fig 8

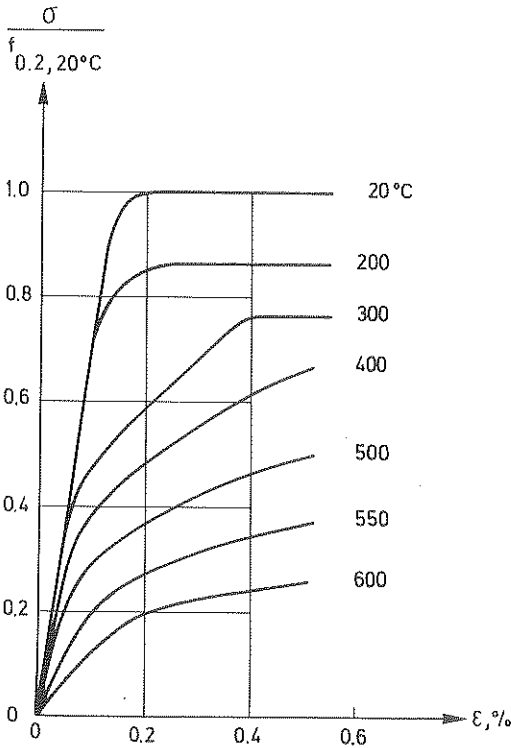

3.5.2 TRANSIENT STATE DATA

b) Reinforcing steel : Ks 60,  $f_{0.2,20^{\circ}\text{C}} = 710 \text{ MPa}$

Test conditions : Constant load control  
Rate of heating,  $\dot{T} = 10^{\circ}\text{C}/\text{min}$

Specimen :  $\varnothing = 8 \text{ mm}$ ,  $\ell = 100 \text{ mm}$

Chem. composition : C P S Mn Si  
0.31 0.040 0.041 1.11 0.033

Remarks : Total deformation minus initial elastic strain as function of temperature at different load levels

Reference : Anderberg (1982)

Fig 9

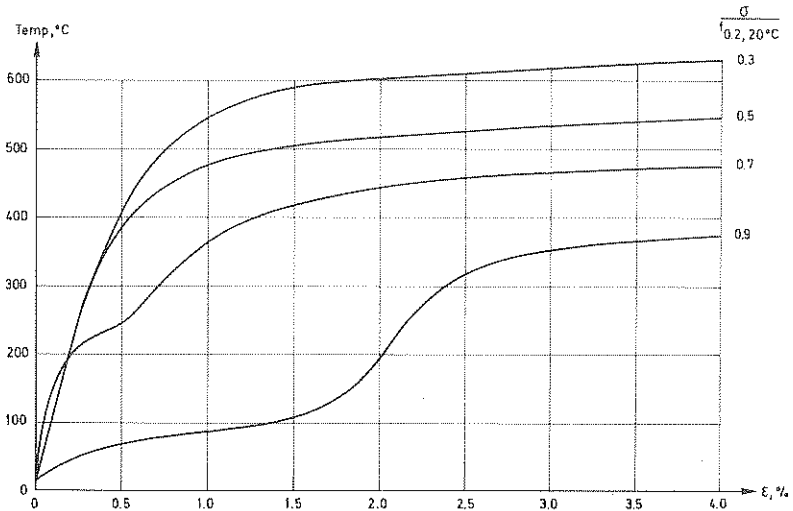

3.5.2 TRANSIENT STATE DATA

- a) Reinforcing steel : ① Hot-rolled,  $f_{0.2,20^{\circ}\text{C}} = 210\text{-}670$  MPa  
② Torsteel,  $f_{0.2,20^{\circ}\text{C}} = 430\text{-}460$  MPa

Test conditions : Constant load control  
Rate of heating,  $\dot{T} = 10^{\circ}\text{C}/\text{min}$

Specimen :  $\phi = 10$  mm,  $l = 400$  mm  
① Hot-rolled  
② Cold-worked

Chem. composition :

Remarks : Total deformation minus initial elastic strain at different load levels as function of temperature

Reference : Soretz (1967)

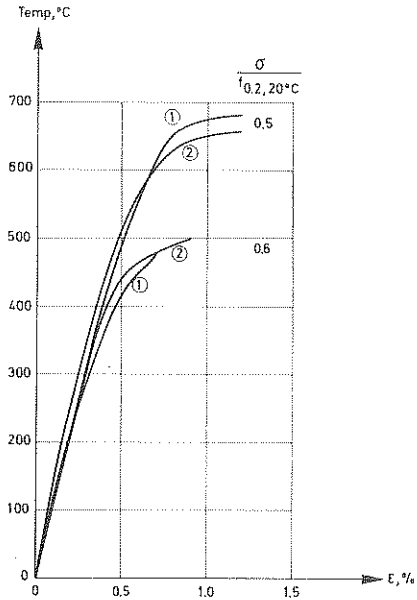

Fig 10



3.5.2 TRANSIENT STATE DATA

c) Prestressing steel :  $f_{0.2, 20^{\circ}\text{C}} = 1559 \text{ MPa}$   
 $f_{u, 20^{\circ}\text{C}} = 1848 \text{ MPa}$

Test conditions : Constant load control  
Rate of heating,  $\dot{T} = 12^{\circ}\text{C}/\text{min}$

Specimen :  $\varnothing = 4.5 \text{ mm}$

Chem. composition :

Remarks : Total deformation as function of temperature at different load levels

Reference : Voves, B. (1978)

Fig 11

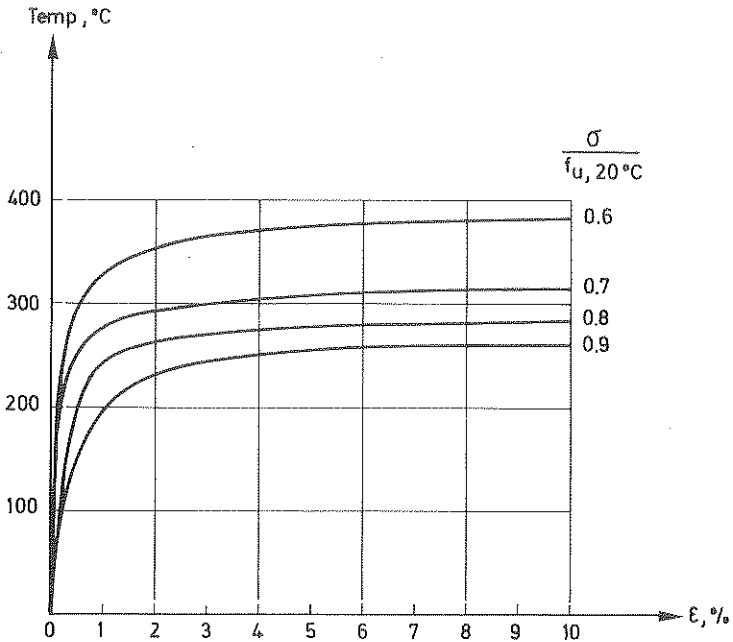

3.5.2 TRANSIENT STATE DATA

c) Prestressing steel : St 1570/1770,  $f_{0.2,20^{\circ}\text{C}} = 1570 \text{ MPa}$

Test conditions : Constant load control  
Rate of heating,  $\dot{T} = 4^{\circ}\text{C}/\text{min}$

Specimen : Cold-drawn,  $\phi = 7.5 \text{ mm}$ ,  $l = 10 \times \phi$

Chem. composition :

Remarks : Total deformation minus initial elastic strain as function of temperature at different load levels

Reference : Ruge & Winkelmann (1978-80)

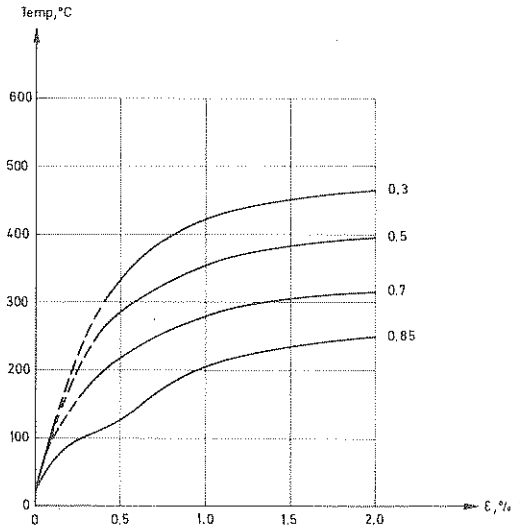

Fig 12

### 3.5.2 TRANSIENT STATE DATA

c) Prestressing steel : St 1570/1770,  $f_{0.2, 20^{\circ}\text{C}} = 1570 \text{ MPa}$

Test conditions : Constant load control  
Rate of heating,  $\dot{T} = 4^{\circ}\text{C}/\text{min}$

Specimen : Cold-worked,  $\phi = 7.5 \text{ mm}$ ,  $\ell = 10 \times \phi$

Chem. composition :

Remarks : Total deformation minus thermal strain  
and initial elastic strain as function  
of temperature at different load levels

Reference : Ruge & Winkelmann (1978-80)

Fig 13

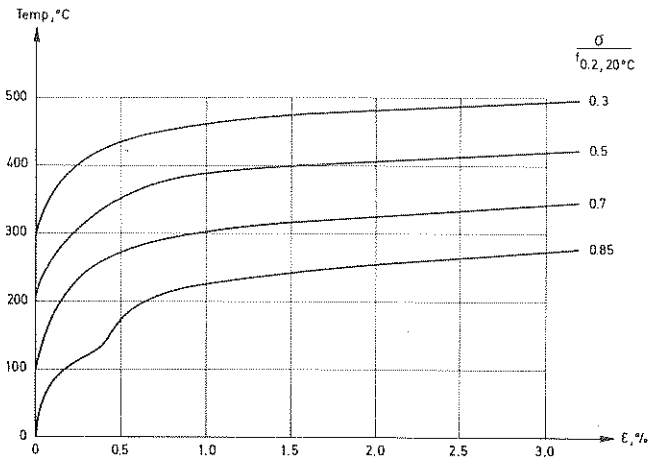

3.5.2 TRANSIENT STATE DATA

c) Prestressing steel : St 1570/1770,  $f_{0.2,20^{\circ}\text{C}} = 1660 \text{ MPa}$

Test conditions : Constant load control  
Rate of heating,  $\dot{T} = 4^{\circ}\text{C}/\text{min}$

Specimen : Cold-worked,  $\phi = 5 \text{ mm}$ ,  $l = 10 \times \phi$

Chem. composition :

Remarks : Total deformation minus initial elastic strain as function of temperature at different load levels

Reference : Ruge & Winkelmann (1978-80)

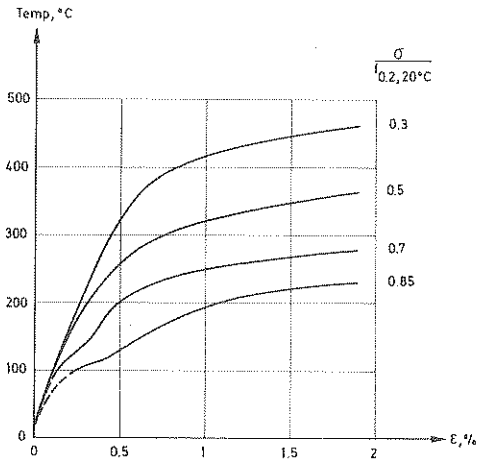

3.5.2 TRANSIENT STATE DATA

c) Prestressing steel : St 1570/1770,  $f_{0.2, 20^{\circ}\text{C}} = 1570 \text{ MPa}$

Test conditions : Constant load control  
Rate of heating,  $\dot{T} = 4^{\circ}\text{C}/\text{min}$

Specimen : Cold-drawn,  $\phi = 7.5 \text{ mm}$

Chem. composition :

Remarks : Constructed  $\sigma$ - $\epsilon$  relationships

Reference : Ruge & Winkelmann (1978-80)

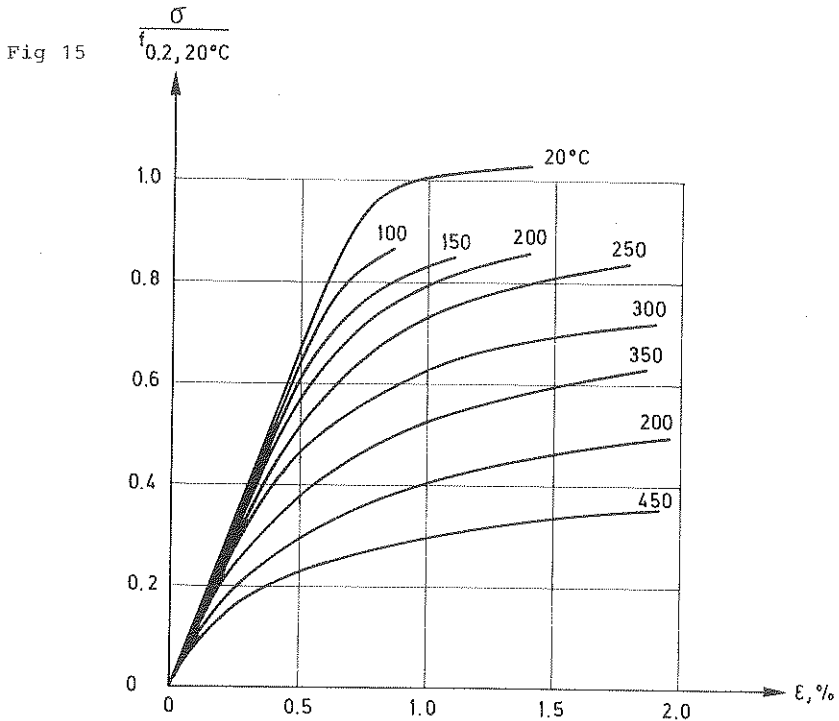

### 3.6 Relaxation

A relaxation test is in most cases carried out at constant strain and temperature and the stress decrease is studied as a function of time. However, in a fire-exposed prestressed concrete structure the temperature is varying and the loss in prestress is due to substantial relaxation. As the temperature increases the relaxation process develops more rapidly, which makes the situation more complicated. The relaxation in prestressed concrete structures can only be studied analytically, which is only done fragmentarily so far.

Dimensionless relaxation curves for reinforcing and prestressing steel are illustrated in Figs. 1-3 from Anderberg (1983), Cahill (1965) and Voves (1978). The results deviate very much from each other, the reason of which is hard to find when only three sources are to be found.

### 3.6 RELAXATION

c) Prestressing steel :  $f_{0.2,20^{\circ}\text{C}} = 1070 \text{ MPa}$   
 $f_{u,20^{\circ}\text{C}} = 1630 \text{ MPa}$

Test conditions : Steady state  
An initial strain related to 0.2% proof stress at each test temperature was kept constant during the test

Specimen :

Chem. composition	C	P	S	Mn	Si
	0.78	0.024	0.022	0.63	0.21

Remarks : Relaxation at different temperatures

Reference : Cahill (1965)

Fig 2

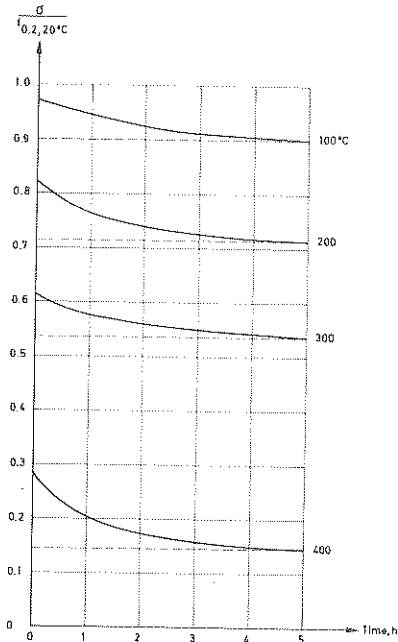

3.6 RELAXATION

b) Reinforcing steel :  $f_{0.2,20^{\circ}\text{C}} = 710 \text{ MPa}$

$f_{u,20^{\circ}\text{C}} = 880 \text{ MPa}$

Test conditions : An initial strain related to different load levels was kept constant at different temperatures

Specimen :  $\varnothing = 8 \text{ mm}$

Chem. composition : 

	C	P	S	Mn	Si
:	0.31	0.040	0.33	1.11	0.041

Remarks : Relaxation at different temperatures

Reference : Anderberg (1983)

Fig 1

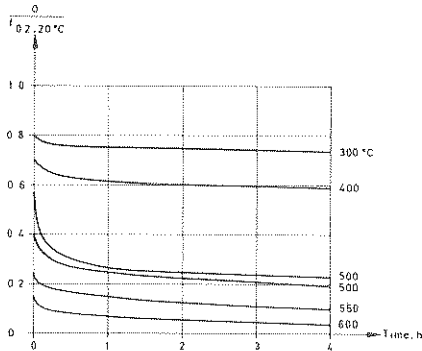



### 3.6 RELAXATION

c) Prestressing steel :  $f_{0.2,20^{\circ}\text{C}} = 1559 \text{ MPa}$   
 $f_{u,20^{\circ}\text{C}} = 1848 \text{ MPa}$

Test conditions : Steady state  
An initial strain related to different load levels was kept constant at different temperatures

Specimen :  $\phi = 4.5 \text{ mm}$

Chem. composition :

Remarks : Relaxation at different temperatures

Reference : Voves, B. (1978)

Fig 3

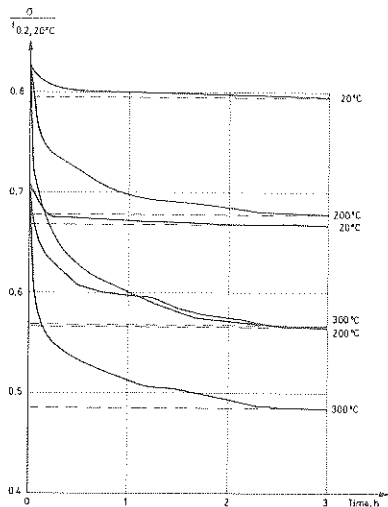

### 3.7 Thermal properties

Information about thermal properties of steel is in literature very limited. Four references are sorted out representing the thermal conductivity, specific heat and specific volumetric enthalpy as function of temperature for structural steel, see Figs 1-4. The thermal conductivity curves taken from three different investigations seem to be in good agreement with each other.

### 3.7 THERMAL PROPERTIES

- a) Structural steel : ① Fe 52  
② Fe 33, Fe 37, Fe 44

Remarks : Thermal conductivity as function of temperature

Reference : ① and ② Stirland (1980)  
③ Alpsten (1967), Wickström (1979)

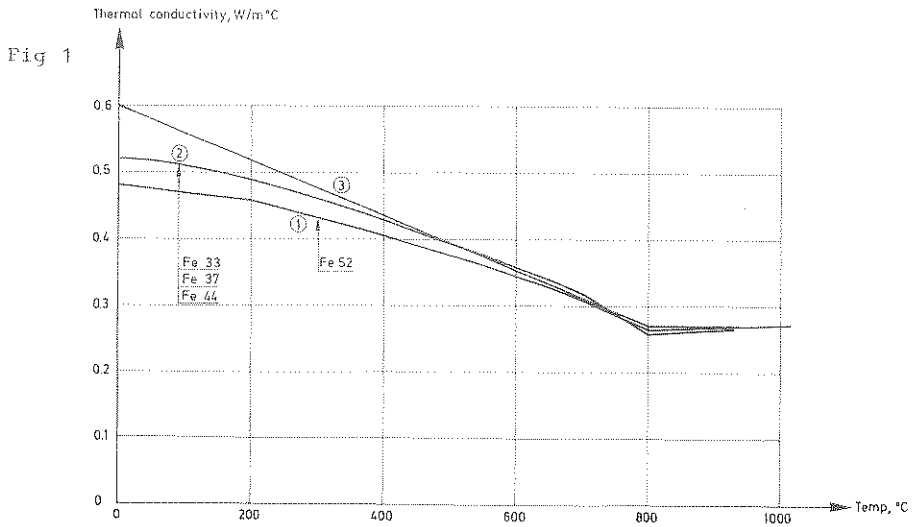

### 3.7 THERMAL PROPERTIES

a) Structural steel :

Remarks : Specific heat as function of temperature

Reference : Stirland (1980)

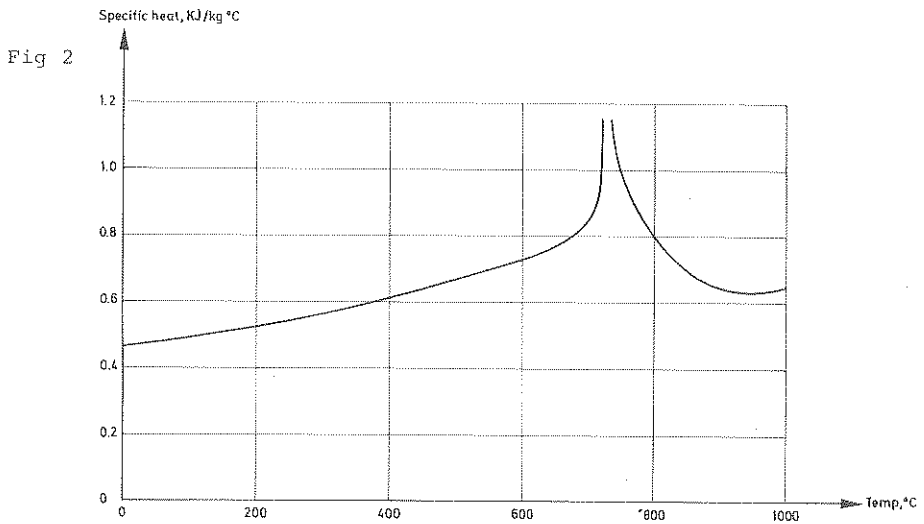

### 3.7 THERMAL PROPERTIES

a) Structural steel :

Remarks : Specific volumetric enthalpy  
as function of temperature

Reference : Alpsten (1967), Wickström (1979)

Fig 3

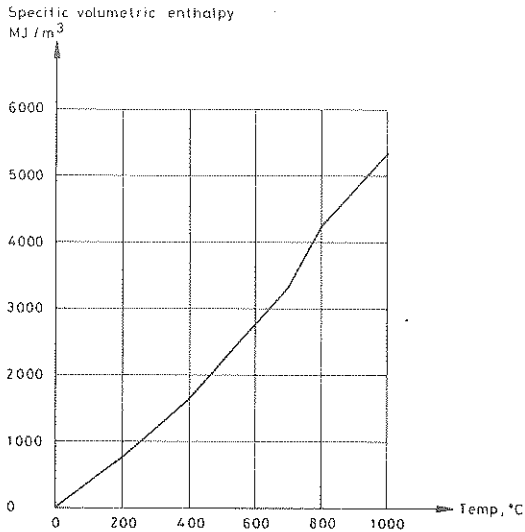

### 3.7 THERMAL PROPERTIES

a,b,c) Different steels :

Remarks : Thermal conductivity as function of temperature

Reference : Schneider & Diederichs (1981)

Fig 4

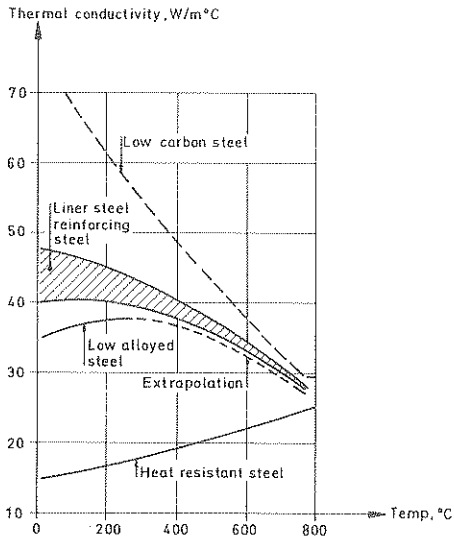

### 3.8 Residual properties

Residual properties as 0.2% proof tensile stress and ultimate tensile strength are illustrated in Figs 1-5. The residual 0.2% proof stress is only meaningful to be measured when the specimen is unloaded during heating and cooling. Hot-rolled steel is not influenced by temperature as concerns neither 0.2% proof stress nor tensile strength. Cold-drawn steel may have some decrease in strength above 500°C (see Fig 4, specimen is loaded during heating), which, however, only amounts to 10% of the original strength. Prestressing steel does not recover from temperatures above about 250°C and exposed to 600°C the residual strength reaches about 0.6  $f_{0.2,20^{\circ}\text{C}}$ .

### 3.8 RESIDUAL PROPERTIES

- a) Structural steel : ① St 60/90,  $f_{0.2,20^{\circ}\text{C}} = 590 \text{ MPa}$
- c) Prestressing steel : ② St 145/165,  $f_{0.2,20^{\circ}\text{C}} = 1520 \text{ MPa}$   
③ St 160...180,  $f_{0.2,20^{\circ}\text{C}} = 1570 \text{ MPa}$
- Test conditions : No loading during heating or cooling
- Specimen : ① Hot-rolled,  $\phi = 26 \text{ mm}$   
② Cold-drawn,  $\phi = 5.2 \text{ mm}$   
③ Cold-drawn,  $\phi = 5 \text{ mm}$
- Chem. composition :
- Remarks : Residual 0.2% proof tensile stress
- Reference : Dannenberg et al (1959)

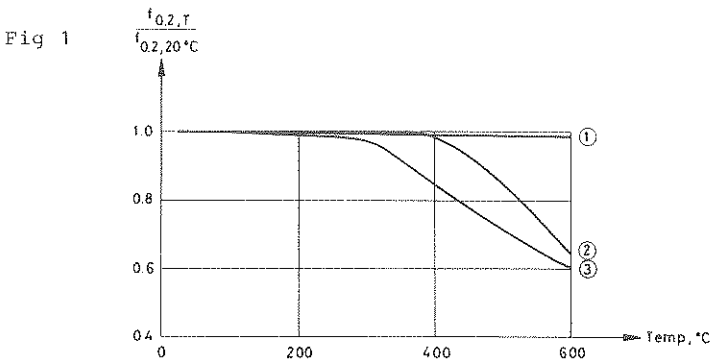



### 3.8 RESIDUAL PROPERTIES

- a) Structural steel : ① St 60/90,  $f_{u,20^{\circ}\text{C}} = 590 \text{ MPa}$
- c) Prestressing steel : ② St 145/165,  $f_{u,20^{\circ}\text{C}} = 1650 \text{ MPa}$   
③ St 160...180,  $f_{u,20^{\circ}\text{C}} = 1740 \text{ MPa}$
- Test conditions : No loading during heating or cooling
- Specimen : ① Hot-rolled,  $\phi = 26 \text{ mm}$   
② Cold-drawn,  $\phi = 5.2 \text{ mm}$   
③ Cold-drawn,  $\phi = 5 \text{ mm}$
- Chem. composition :
- Remarks : Residual ultimate tensile strength
- Reference : Dannenberg et al (1959)

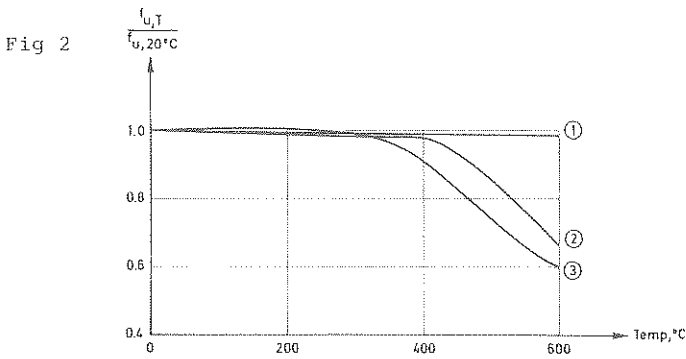

3.8 RESIDUAL PROPERTIES

a) Structural steel : BSt 37-2,  $f_{0.2,20^{\circ}\text{C}} = 255 \text{ MPa}$

Test conditions : Rate of heating,  $\dot{T} = 10^{\circ}\text{C}/\text{min}$

Specimen :  $b = 10 \text{ mm}$ ,  $l = 100 \text{ mm}$

Chem. composition :

Remarks : Residual ultimate tensile strength

Reference : Ruge & Winkelmann (1978-80)

Fig 3

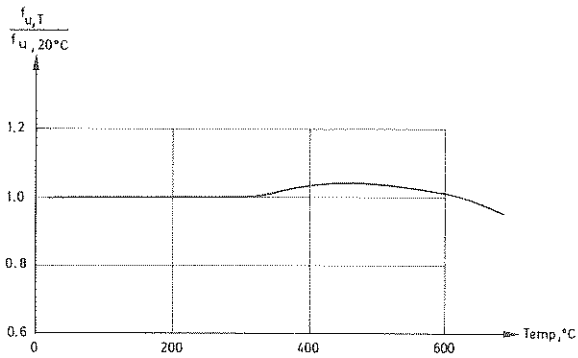

### 3.8 RESIDUAL PROPERTIES

b) Reinforcing steel : BST 42/50 RK ①  $f_{0.2, 20^{\circ}\text{C}} = 430 \text{ MPa}$   
②  $f_{0.2, 20^{\circ}\text{C}} = 470 \text{ MPa}$

Test conditions : Rate of heating,  $\dot{T} = 10^{\circ}\text{C}/\text{min}$

Specimen :  $\phi = 18 \text{ mm}, l = 10 \times \phi$   
 $\phi = 28 \text{ mm}, l = 10 \times \phi$   
Cold-drawn

Chem. composition :

Remarks : Residual ultimate tensile strength

Reference : Ruge & Winkelmann (1978-80)

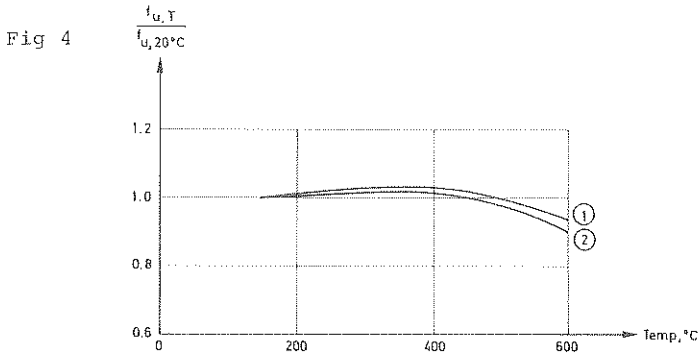

3.8 RESIDUAL PROPERTIES

c) Prestressing steel :  $f_{0.2, 20^{\circ}\text{C}} = 1559 \text{ MPa}$   
 $f_{u, 20^{\circ}\text{C}} = 1848 \text{ MPa}$

Test conditions : Heated to a specified temperature level with a stabilizing period of 10 minutes before a cooling down to room temperature

Specimen :  $\phi = 4.5 \text{ mm}$

Chem. composition :

Remarks : Residual ultimate tensile strength and 0.2% proof stress

Reference : Voves, B. (1978)

Fig 5

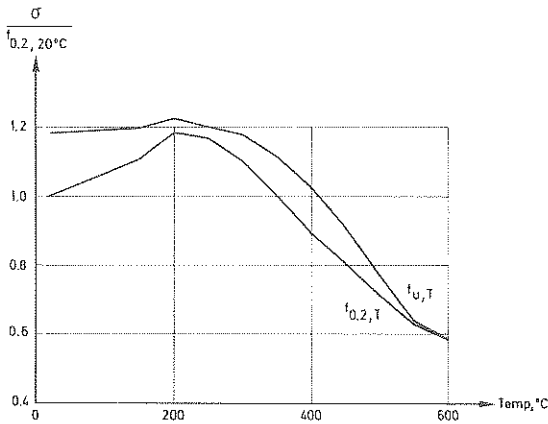

#### 4 A review and comparative study of different properties

When the results are comparable (i.e. test procedure is similar), it can be shown that the relative decrease in ultimate tensile strength with increasing temperature in most cases is almost the same for all steels, prestressing steels and others separated. Some deviations may occur for cold-worked steel. For hot-rolled steel the decrease in 0.2% proof stress has the same tendency.

When comparing the ultimate strength curves obtained from a steady state test with stress rate control and from a transient state test, a difference can be observed as illustrated for hot-rolled steels in Fig 12. The transient test results are here about 10% lower at temperatures above 450°C. If, however, the stress rate had been chosen much lower, the curves should be much closer to each other.

$\sigma$ - $\epsilon$  relationships on stress rate controlled steady state conditions for Swedish hot-rolled steel and different structural steels are compared in Figs 13-15. The  $\sigma$ - $\epsilon$  curves shown in Fig 13 are in good agreement due to very similar test conditions. The agreement is not that good in Figs 14 and 15, which may be explained by the fact that the exact test conditions are not known for Reichel's results.

A similar comparison is illustrated for two kinds of structural steel under strain rate controlled steady state conditions. The  $\sigma$ - $\epsilon$  curves are in good concordance with each other.

In transient tests the rate of heating influences the deformation-temperature curve. Comparing results when  $\dot{T} = 10^{\circ}\text{C}/\text{min}$  for reinforcing and structural steels, curves as illustrated in Fig 17 are obtained. The curves are quite close to each other. The instability phase at about 275°C, however, are more marked in Copier's results.

From transient test results  $\sigma$ - $\epsilon$  curves can be evaluated. Such curves on structural steel from two different sources are compared in Fig 18. The curves from Ruge & Winkelmann are all above those from Copier.

In Fig 19  $\sigma$ - $\epsilon$  curves from steady state and transient state tests on prestressing steel are compared. The curves on steady state conditions are lying above the corresponding constructed curves. If, however, the stress rate or strain rate in the steady state test is chosen lower, the curves are approaching each other.

Theoretically, it is possible to evaluate what stress rate or strain rate in a steady state test that shall be coupled with a certain rate of temperature increase in a transient test in order to get the same  $\sigma$ - $\epsilon$  curve or ultimate strength. Analytical modelling will be discussed and illustrated in chapter 5.

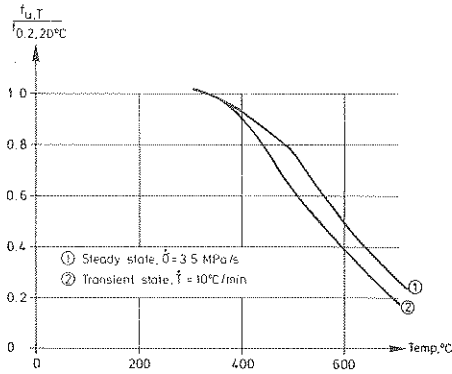

Fig 12 Ultimate strength as function of temperature for hot-rolled steels in (1) a steady state test and in (2) a transient state test. Anderberg (1982)

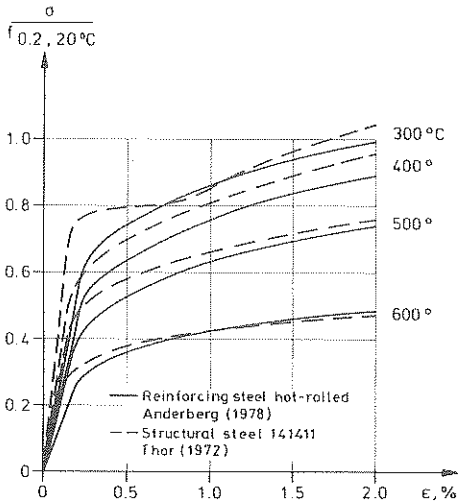

Fig 13  $\sigma$ - $\epsilon$  curves from steady state tests under stress rate control for reinforcing and structural steel.  $\dot{\sigma} = 3.5$  and  $1.6 \text{ MPa/s}$ , respectively

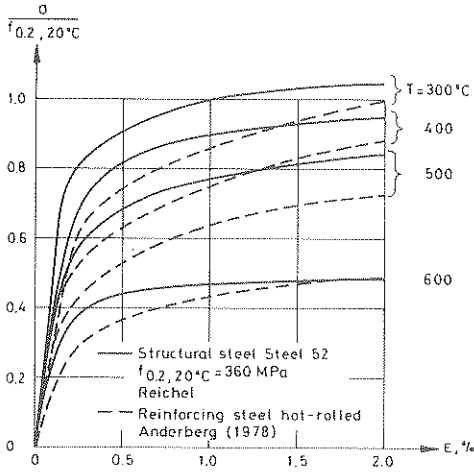

Fig 14  $\sigma$ - $\epsilon$  curves from steady state tests under stress rate control for structural and reinforcing steel

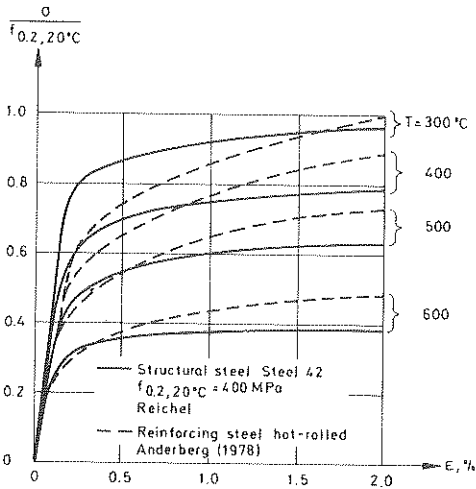

Fig 15  $\sigma$ - $\epsilon$  curves from steady state tests under stress rate control for structural and reinforcing steel



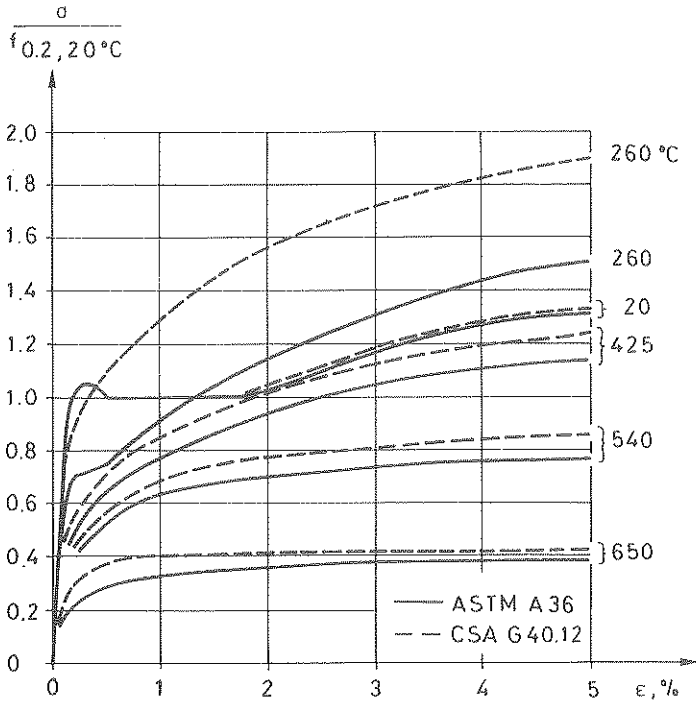

Fig 16  $\sigma$ - $\epsilon$  curves from steady state tests under strain rate control for different structural steels.  
 $\dot{\epsilon} = 50-100 \cdot 10^{-3} \cdot \text{min}^{-1}$ . Harmathy & Stanzak (1970)

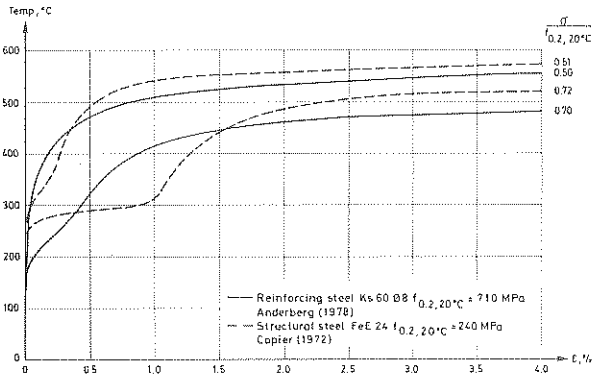

Fig 17 Total deformation minus initial elastic and thermal strain as function of temperature for reinforcing and structural steel.  
 $\dot{T} = 10^\circ\text{C}/\text{min}$

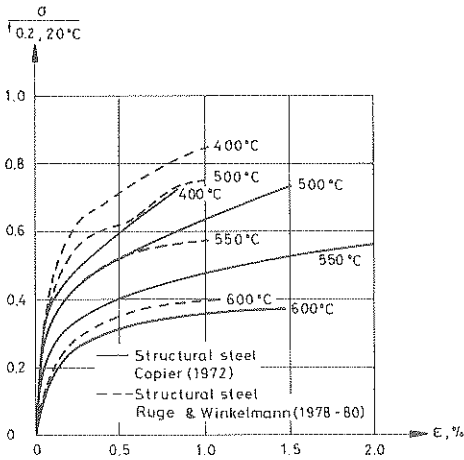

Fig 18 Calculated  $\sigma$ - $\epsilon$  curves from transient tests for structural steel.  
 $\dot{T} = 10^\circ\text{C}/\text{min}$ .

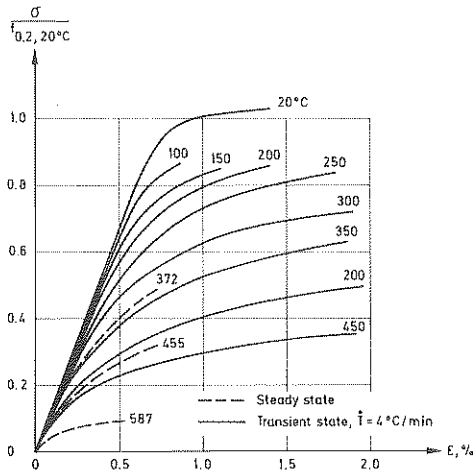

Fig 19 A comparison of  $\sigma$ - $\epsilon$  curves for prestressing steel St 1570/1770 obtained from steady state and transient state tests

## 5 Analytical modelling

### 5.1 Models

It is generally agreed that the deformation process of steel at elevated temperatures can be described by the three strain components defined below, namely thermal strain, instantaneous, stress-related strain and creep strain. Thus

$$\epsilon_{\text{total}} = \epsilon_{\text{t}} = \epsilon_{\text{th}}(T) + \epsilon_{\sigma}(T, \sigma) + \epsilon_{\text{cr}}(t, T, \sigma) \quad (1)$$

where

$\epsilon_{\text{th}}(T)$  = thermal strain

$\epsilon_{\sigma}(T, \sigma)$  = instantaneous, stress-related strain based on  $\sigma$ - $\epsilon$  relationship

$\epsilon_{\text{cr}}(t, T, \sigma)$  = creep strain or time dependent strain

The strains are found separately in steady state tests and several analytical expressions are presented in literature. Behaviour models based on steady state data only partially predict the transient behaviour of any given fire process, load and strain history.

An analytical description of the  $\sigma$ - $\epsilon$  curve as a function of temperature can be made in different ways as illustrated in Figs 20 and 21. In the first case the curve is approximated by two straight lines and in the second case by an elliptic branch placed between straight lines. The curve can also be approximated by other analytical expressions.

Models of creep are in most cases based on a concept put forward by Dorn (1954), in which the effect of variable temperatures is considered. The extension of the model to be applicable to variable stress can, for instance, be based on the strain hardening rule.

The creep strain is assumed to be dependent on the magnitude of stress and on the temperature-compensated time evaluated

from the expression

$$\theta = \int_0^t e^{-\frac{\Delta H}{RT}} dt \quad (h) \quad (2)$$

where

$\Delta H$  = activation energy of creep, J/mol  
 $R$  = gas constant, J/mol·K  
 $t$  = time

The relation between creep strain,  $\epsilon_{cr}$ , and temperature-compensated time,  $\theta$ , at different stress levels is shown principally in Fig 22. The change from the curved branch to the straight line (primary and secondary phase) is denoted by  $\theta_0$  and the intersection between the straight line and the creep axis is called  $\epsilon_{cr,0}$ . The slope of the straight line is called  $Z$ . Harmathy (1967) has derived an analytical expression between  $\epsilon_{cr}$  and the parameters  $\theta$ ,  $Z$  and  $\epsilon_{cr,0}$  as follows:

$$\epsilon_{cr} = (\epsilon_{cr,0}/\ln 2) \operatorname{arcosh} (2^{Z\theta/\epsilon_{cr,0}}) \quad (3)$$

A modified expression is also made by Plem (1975) where the primary phase is defined by a parabolic equation and the secondary phase by a linear slope. The transfer occurs at time  $\theta_0$ . The mathematical formula is

$$\left. \begin{aligned} \epsilon_{cr} &= \epsilon_{cr,0} \left( 2 \cdot \sqrt{\frac{Z \cdot \theta}{\epsilon_{cr,0}}} \right) && \text{when } 0 \leq \theta \leq \theta_0 \\ \epsilon_{cr} &= \epsilon_{cr,0} \left( 1 + \frac{Z \cdot \theta}{\epsilon_{cr,0}} \right) && \text{when } \theta \geq \theta_0 \end{aligned} \right\} \quad (4)$$

where

$$\theta_0 = \frac{\epsilon_{cr,0}}{Z} \quad (5)$$

A simplified way is to approximate the creep curve by two straight branches with slopes  $Z_p$  and  $Z_s$  (Anderberg 1978)

as illustrated in Fig 23. The creep strain is an explicit function of time, temperature and stress, where

$$\epsilon_{cr}(t, T, \sigma) = t \cdot Z(T, \sigma) \quad (6)$$

$$\left. \begin{aligned} \dot{\epsilon}_{cr} &= Z_p(T, \sigma) & \text{if } 0 \leq t \leq t_t \\ \dot{\epsilon}_{cr} &= Z_s(T, \sigma) & \text{if } t > t_t \end{aligned} \right\} \quad (7)$$

Nomograms for the rate of creep in primary and secondary phase for reinforcing steel Ks 40 Ø8 were published by Anderberg (1978). These nomograms including the determination of the transition time,  $t_t$ , are given in Fig 24. These diagrams facilitate an estimation of the magnitude of creep.

The Dorn-Harmathy creep theory has not only been used by Harmathy but also by Thor (1972). In Figs 25-27 the validity of the creep model can be studied. The agreement is satisfactory. In Anderberg (1978) the modified version of the Dorn-Harmathy theory has been used and the concordance between test and calculation is shown in Figs 28-30.

Creep parameters for different kind of steels and used in calculations are collected in Table 5.1. The following equations are governing Z and  $\epsilon_{cr,0}$ :

$$\epsilon_{cr,0} = A \cdot \sigma^B \quad (8)$$

$$Z = \begin{cases} C \cdot \sigma^D & \text{if } \sigma \leq \text{SIG } 1 \\ H \cdot e^{F \cdot \sigma} & \text{if } \sigma > \text{SIG } 1 \end{cases} \quad (9)$$

The coefficients in these equations are given in Table 5.1 for steels accounted for in three sources, 1. Thor (1972), 2. Harmathy & Stanzak (1970) and 3. Anderberg (1978).

## 5.2 Comparison test and calculation

Using the complete behaviour model as expressed in Eq (1), any test can be simulated. The total deformation as a function of

temperature measured in a transient test,  $\dot{T} = 10^{\circ}\text{C}/\text{min}$ , is calculated in Anderberg (1983) and the comparison is illustrated in Fig 31. The calculation is very close to the measured curves.  $\sigma$ - $\epsilon$  curves from steady state and transient state tests at different temperatures are compared to each other in Fig 32. Agreement between calculations and measurements is also close in this case. The curve of the steady state conditions contains no creep due to the high stress rate. In the curve of the transient state conditions the influence of creep, however, is of importance. The difference between the curves at  $\epsilon > 2\%$  and the decrease in ultimate strength at 500 and 600 $^{\circ}\text{C}$  amount to about 15% of  $f_{0.2,20^{\circ}\text{C}}$ .

$\sigma$ - $\epsilon$  curves from steady state tests (strain controlled) on prestressing steel are compared to calculated data in Fig 33. The agreement is very good up to the maximum stress. However, the negative slope is not obtained in the calculation which may be due to a contraction of the steel area during the experiment. The reduced cross-section causes a decrease in total load but the stress may be constant?

It is also possible to simulate a relaxation test. A comparison is made between measured curves (Cahill 1965) and curves predicted on the basis of creep data according to A421-65 (Harmathy 1967). The result is illustrated in Fig 34. The American prestressing steel seems to be a little more sensitive to relaxation above 300 $^{\circ}\text{C}$ , but at 400 $^{\circ}\text{C}$  the curves are close to each other.

The predictions illustrated above indicate that any test process can be calculated satisfactorily, when the model is based on steady state data.

Table 5.1

Creep parameters for different kind of steels (1) Thor (1972), (2) Harmathy-Stanzak (1970) and (3) Anderberg (1978)

Stál	$f_{0,2,20^{\circ}\text{C}}$ MPa	A	B	C $\text{min}^{-1}$	D	H $\text{min}^{-1}$	F	$\frac{\Delta H}{R}$ K	STG 1 MPa
(1)	1312 (test 1)	$5.56 \cdot 10^{-6}$	1.722	$6.083 \cdot 10^{+9}$	7.808	$1.383 \cdot 10^{+23}$	0.0578	55 800	108
	1312 (test 2)	$2.66 \cdot 10^{-7}$	2.248	$9.95 \cdot 10^{+8}$	7.644	$5 \cdot 10^{+21}$	0.0601	53 900	108
	1411 (Thor)	$3.52 \cdot 10^{-7}$	2.08	$6.767 \cdot 10^{+12}$	8.402	$4.417 \cdot 10^{+27}$	0.0603	66 000	118
	A36-66	$4.07 \cdot 10^{-6}$	1.75	$6.217 \cdot 10^{+6}$	4.70	$2 \cdot 10^{+14}$	0.0434	38 900	103
	2172	$2.085 \cdot 10^{-6}$	2.30	$1.33 \cdot 10^{+10}$	5.38	$1.083 \cdot 10^{+19}$	0.0446	50 000	108
	G40-12	$1.766 \cdot 10^{-7}$	1.00	$4.733 \cdot 10^{+7}$	3.25	$6.17 \cdot 10^{+12}$	0.0319	36 100	103
(2)	A421-65	$9.262 \cdot 10^{-5}$	0.67	$3.253 \cdot 10^{+6}$	3.0	$1.368 \cdot 10^{+12}$	0.0145	30 600	172
(3)	Ks 40 $\emptyset$ 10	$28.5 \cdot 10^{-9}$	1.037	$1.16 \cdot 10^{+9}$	4.7	$4.3 \cdot 10^{+16}$	0.0443	45 000	84
	Ks 40 $\emptyset$ 8	$3.39 \cdot 10^{-7}$	0.531	$7.6 \cdot 10^{+5}$	4.72	$1.25 \cdot 10^{+13}$	0.0512	40 000	90
	Ks 40 $\emptyset$ 8	$19.9 \cdot 10^{-6}$	1.28	$4.05 \cdot 10^{+4}$	7.26	$5.0 \cdot 10^{+17}$	0.0384	47 000	120
	Ks 40 SP $\emptyset$ 8	$38.6 \cdot 10^{-9}$	1.117	$5.8 \cdot 10^{+7}$	3.83	$4.133 \cdot 10^{+13}$	0.0414	40 000	96
	Ks 60 $\emptyset$ 8	$2.06 \cdot 10^{-6}$	0.439	$5.111 \cdot 10^{+7}$	2.93	$2.65 \cdot 10^{+14}$	0.0313	40 000	90
	Ps 50 $\emptyset$ 5	$1.10 \cdot 10^{-6}$	0.557	$9.738 \cdot 10^{+6}$	4.47	$2.133 \cdot 10^{+15}$	0.0368	40 000	100
	Ps 50 $\emptyset$ 6	$1.28 \cdot 10^{-7}$	0.844	$1.367 \cdot 10^{+8}$	3.94	$1.62 \cdot 10^{+15}$	0.0368	41 000	133

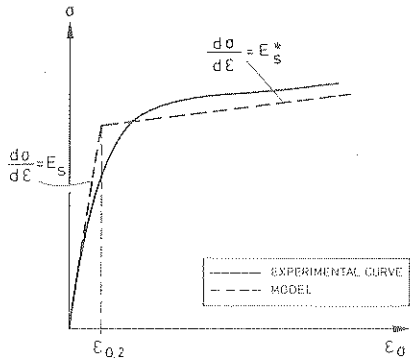

Fig 20 Simplified model of the stress-strain curve for steel

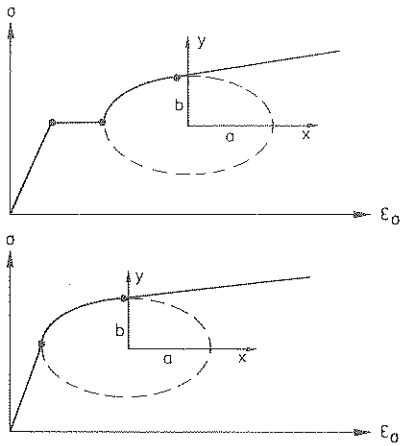

Fig 21 Refined model of the stress-strain curve for steel



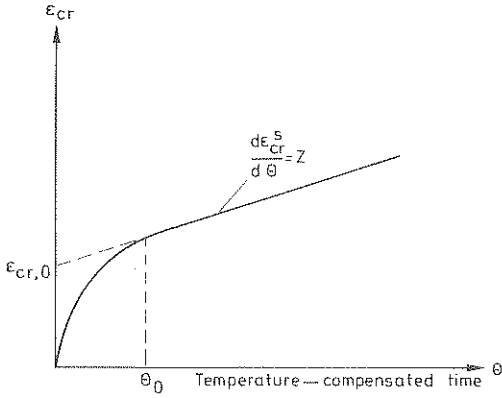

Fig 22 Principal creep curve for steel according to Dorn's theory

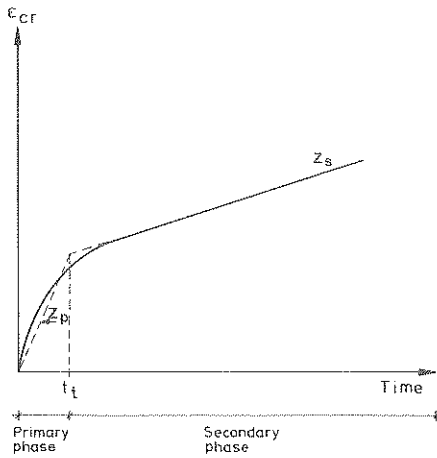

Fig 23 Measured creep curve approximated by two straight branches with slopes  $Z_p$  and  $Z_s$

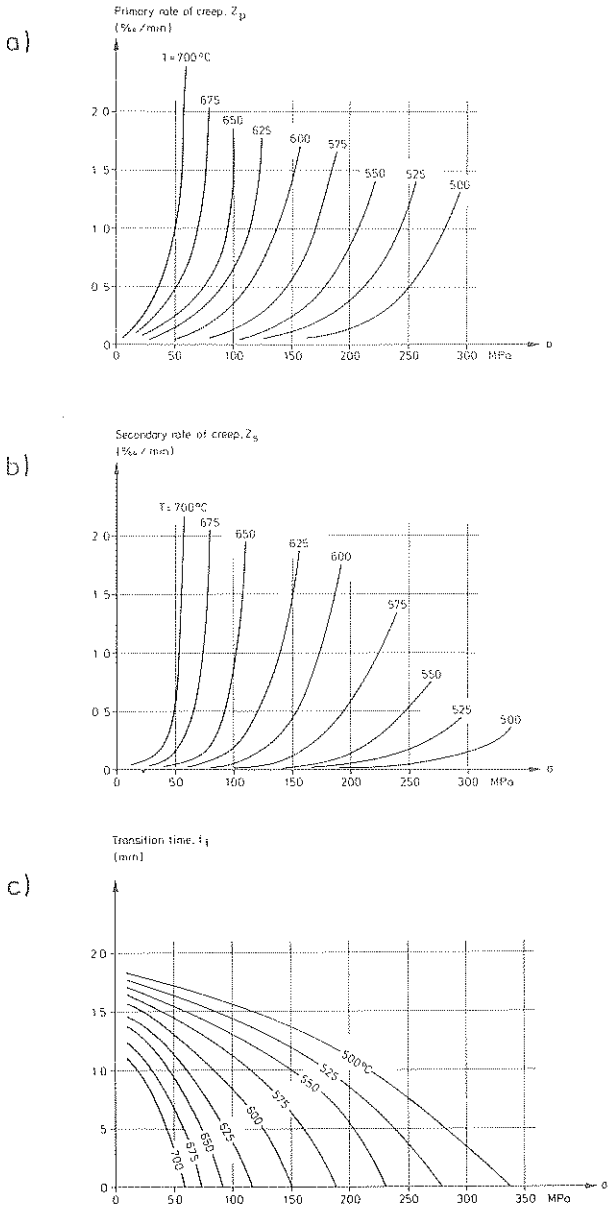

Fig 24 Nomogram for rate of creep

- a) Primary phase
- b) Secondary phase
- c) Transition between primary and secondary phase

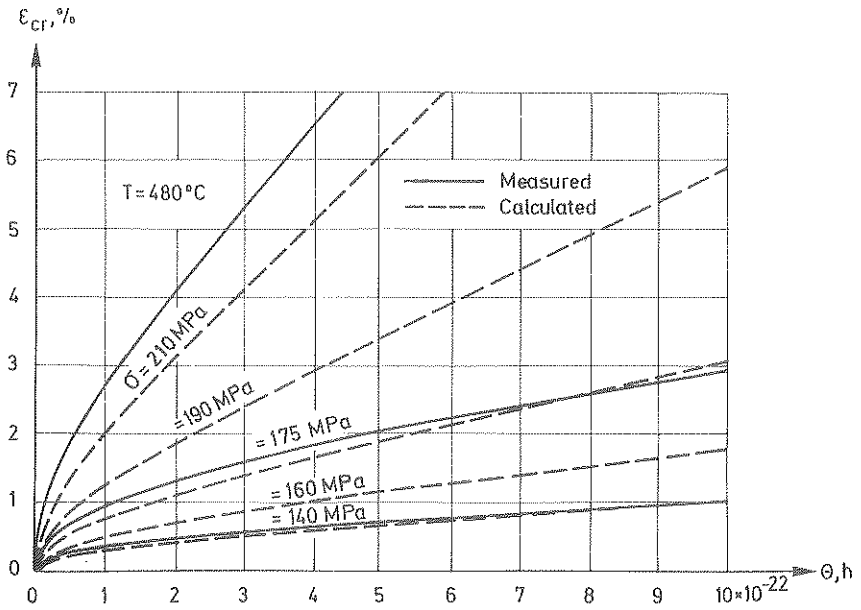

Fig 25 Measured and predicted creep (Dorn-Harmathy theory) at different stress levels. Structural steel ASTM A36,  $f_{0.2, 20^\circ\text{C}} = 300 \text{ MPa}$ , Harmathy (1967)

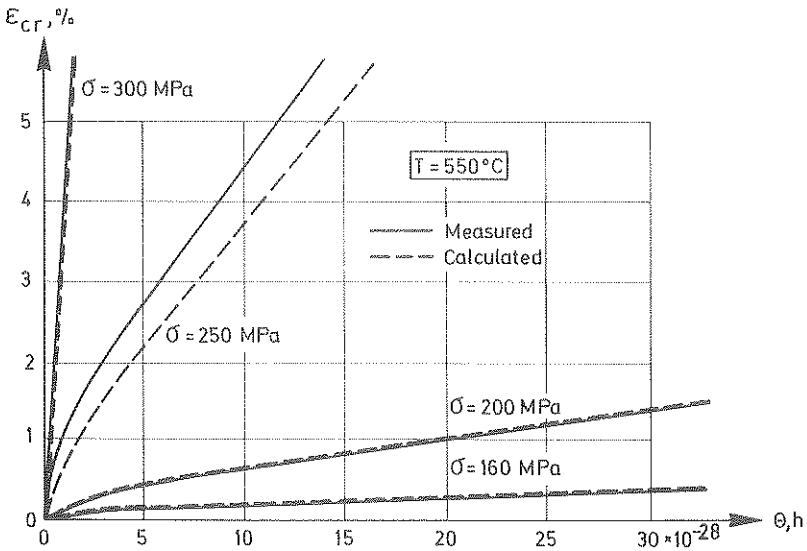

Fig 26 Measured and predicted creep (Dorn-Harmathy theory) at different stress levels. Structural steel SIS 142172,  $f_{0.2, 20^\circ\text{C}} = 340 \text{ MPa}$ , Thor (1972)

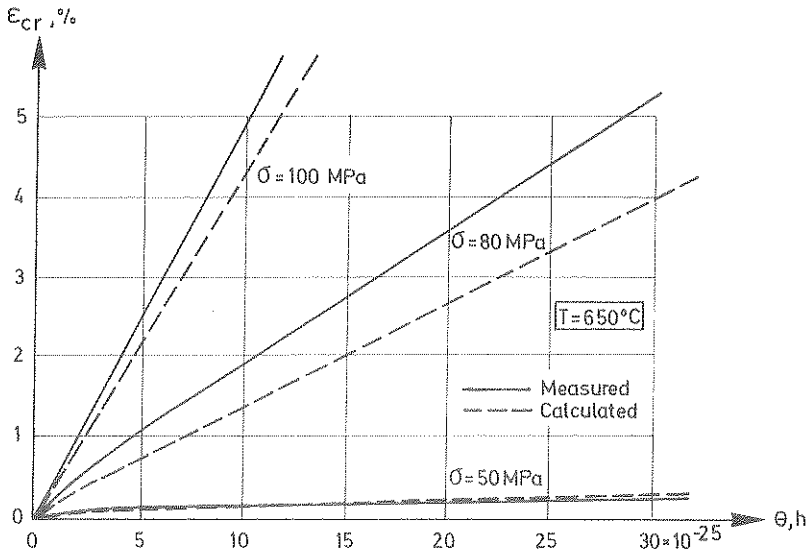

Fig 27 Measured and predicted creep (Dorn-Harmathy theory) at different stress levels. Structural steel SIS 142172,  $f_{0.2, 20^{\circ}\text{C}} = 340 \text{ MPa}$ , Thor (1972)

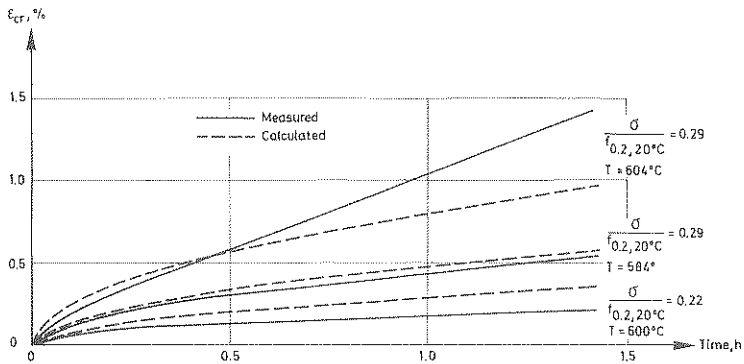

Fig 28 Measured and predicted creep (modified Dorn-Harmathy theory) at different stress levels. Reinforcing steel Ks 40 Ø8,  $f_{0.2, 20^{\circ}\text{C}} = 456 \text{ MPa}$ , Anderberg (1978)

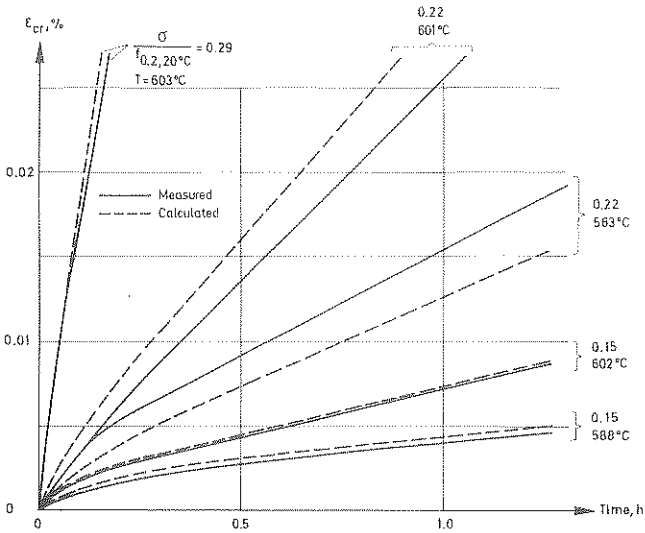

Fig 29 Measured and predicted creep (modified Dorn-Harmathy theory) at different stress levels. Reinforcing steel Ks 60 Ø8,  $f_{0.2,20^\circ\text{C}} = 710 \text{ MPa}$ , Anderberg (1978)

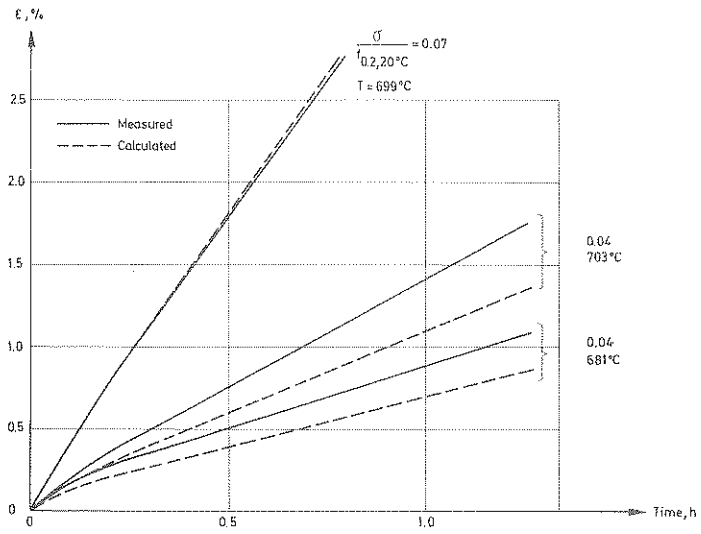

Fig 30 Measured and predicted creep (modified Dorn-Harmathy theory) at different stress levels. Reinforcing steel Ks 60 Ø8,  $f_{0.2,20^\circ\text{C}} = 710 \text{ MPa}$ , Anderberg (1978)

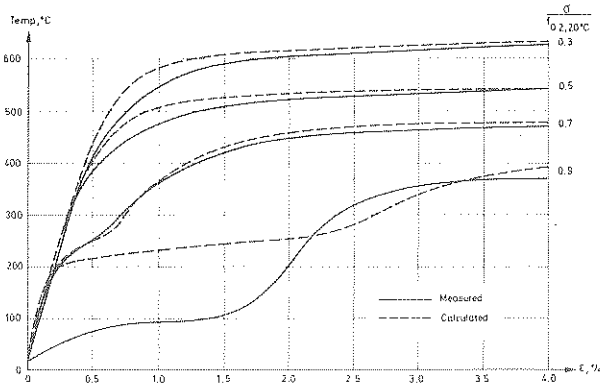

Fig 31 Measured and predicted total deformation as a function of temperature at different load levels in a transient process,  $\dot{T} = 10^\circ\text{C}/\text{min}$ . Reinforcing steel Ks 60 Ø8,  $f_{0.2, 20^\circ\text{C}} = 710 \text{ MPa}$ , Anderberg (1978)

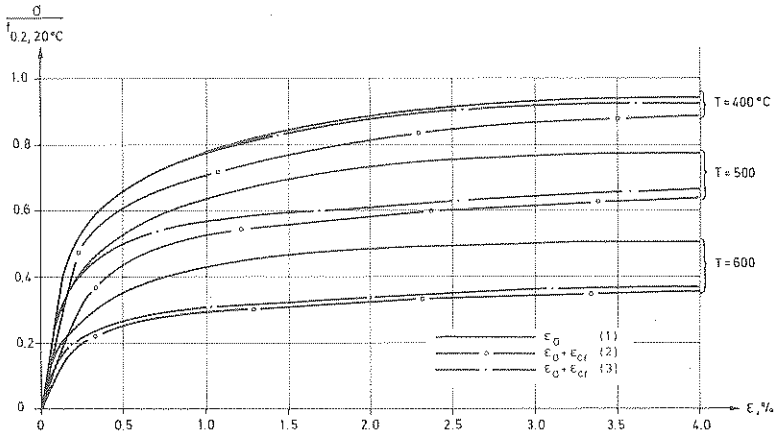

Fig 32 Measured and predicted  $\sigma$ - $\epsilon$  curves from steady state and transient state tests.

1. Steady state test, stress-controlled,  $\dot{\sigma} = 3.5 \text{ MPa/s}$
2. Transient state test, constructed curve,  $\dot{T} = 10^\circ\text{C}/\text{min}$
3. Transient process, curve derived analytically,  $\dot{T} = 10^\circ\text{C}/\text{min}$

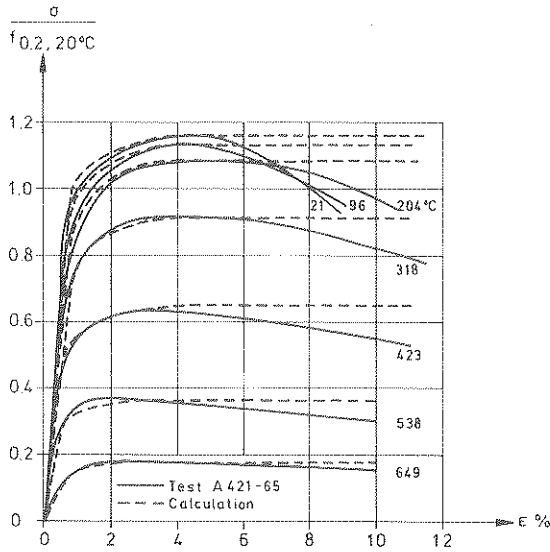

Fig 33 Measured and predicted  $\sigma$ - $\epsilon$  curves from strain controlled steady state tests on prestressing steel ( $\dot{\epsilon} = 700 \cdot 10^{-3} \cdot \text{min}^{-1}$ ). Anderberg (1983)

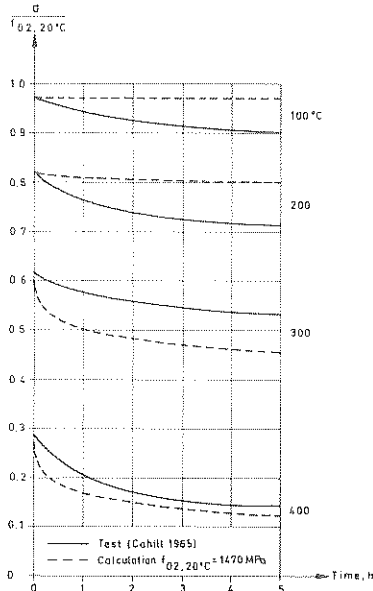

Fig 34 Measured and predicted relaxation curves for pre-stressing steel. Calculation is based on creep data of A421-65, published in Harmathy 1967. Anderberg (1983)

### 5.3 How to compare results obtained at different test procedures

Analytical modelling opens up the possibility of relating steady state and transient state tests. For instance, the strain or stress rate can be determined in steady state tests to give the same ultimate strength as occurs in a transient test for a given rate of heating.

The predicted influence of stress and strain rates on the stress-strain relationship under steady state conditions can be studied in Figs 35-37. From such curves the ultimate strength as a function of temperature can be evaluated (Figs 38-41). In Fig 40 a-b, the influence of stress and strain rates on the ultimate strength under steady state conditions is illustrated. The influence of rate of temperature under transient state conditions is given in Fig 40 c. The ultimate strength is defined by the stress at which the strain is 4%, the thermal strain excluded.

In the analytical modelling (Anderberg 1983) the strain and stress rate in a steady state procedure to give the same ultimate strength as under transient state conditions is found, if the rate of heating is chosen to 10°C/min. The result is shown in Fig 40 d for a specific reinforcing steel (Ks 60,  $f_{0.2,20^{\circ}\text{C}} = 710$  MPa). The strain and stress rates obtained by computation are thus

$$\dot{\epsilon} = 20\%/min$$

and

$$\dot{\sigma} = 0.20 \text{ MPa/s} = 12 \text{ MPa/min}$$

These values presented here vary somewhat depending on the type of steel, which is shown in Table 5.3.1 for

- a) structural steel 1411,  $f_{0.2,20^{\circ}\text{C}} = 340$  MPa
- b) hot-rolled reinforcing steel Ks 40,  $f_{0.2,20^{\circ}\text{C}} = 456$  MPa
- c) hot-rolled reinforcing steel Ks 60,  $f_{0.2,20^{\circ}\text{C}} = 710$  MPa
- d) prestressing steel ASTM A 421-65,  $f_{0.2,20^{\circ}\text{C}} = 1470$  MPa



Table 5.3.1 (Anderberg 1983)

Type of steel	$\dot{T}$ °C/min	$\dot{\sigma}$ MPa/s	$\dot{\epsilon}$ %/min
Steel 1411	10	0.20	10
Ks 40	10	0.20	10
Ks 60	10	0.20	20
ASTM A 421-65	10	0.50	10

For the additional steels in Table 5.3.1 the results of computation are given in Figs 38-39, 41.

If the strength-temperature curve, based on the transient state condition where for instance  $\dot{T} = 10^{\circ}\text{C}/\text{min}$  is accepted as a reference curve, test results can be directly interpreted and, thus, comparable. If the rates  $\dot{\epsilon}$  and  $\dot{\sigma}$  are below the values mentioned above, the measured ultimate strength should be corrected upwards. If one has the opposite situation the strength values are corrected downwards.

The rate of stress or strain in a steady state test and the rate of temperature in a transient test are governing the development of creep which causes the change in the ultimate strength. The influence of creep for three different procedures is also fully illustrated in Figs 35-41. It is also important to observe that there is a great difference between the time history of creep development in a stress and strain controlled steady state test. This is principally illustrated in Fig 42, where curve 1 represents a stress-strain curve at a very high stress or strain rate and curve 2 and 2' represent a curve at a slow stress and strain rate, respectively. The points A and A' indicate the time at which creep starts to be significant and point B is the assumed failure point ( $\epsilon = 4\%$ ). In the stress controlled test the time to reach point A is about 50% of the total testing period but in the strain controlled test the corresponding time is only about 15%. If a test is carried out at  $600^{\circ}\text{C}$  at the stress rate  $\dot{\sigma} = 12 \text{ MPa}/\text{min}$  and at the strain rate  $\dot{\epsilon} = 20\%/ \text{min}$  the testing period amounts to 22 and 2 min, respectively. Although these differences exist, the creep influence on the ultimate strength is the same. In the corresponding transient test this period is about 58 min. This means that the testing period is not a critical parameter in the analytical study by rather the time period of the test when creep develops.

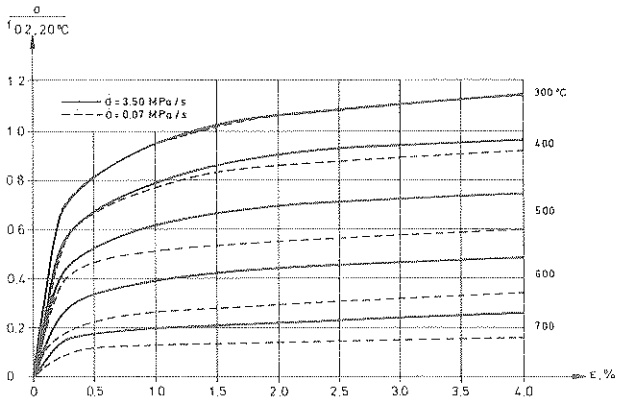

Fig 35 Predicted  $\sigma$ - $\epsilon$  curves at different stress rates for reinforcing steel ( $K_s 60$ ,  $f_{0.2, 20^\circ\text{C}} = 710 \text{ MPa}$ ). Anderberg (1983)

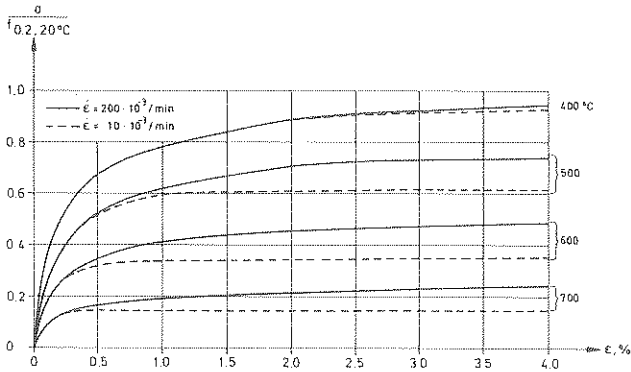

Fig 36 Predicted  $\sigma$ - $\epsilon$  curves at different strain rates for reinforcing steel ( $K_s 60$ ,  $f_{0.2, 20^\circ\text{C}} = 710 \text{ MPa}$ ). Anderberg (1983)

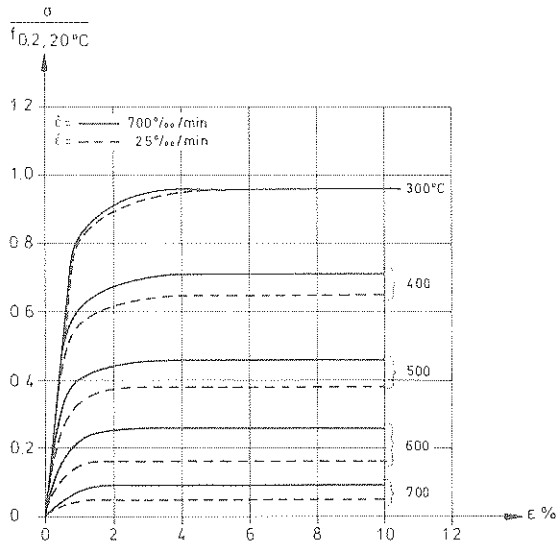
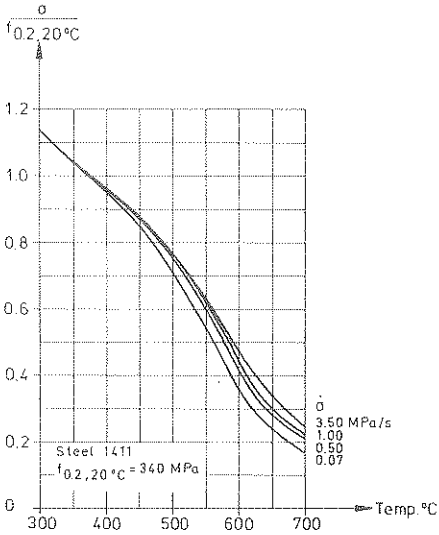
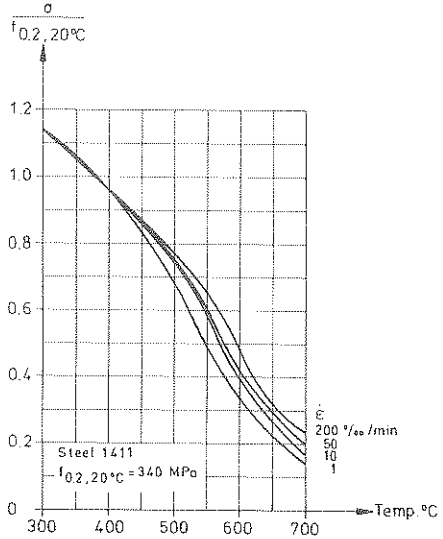

Fig 37 Predicted  $\sigma$ - $\epsilon$  curves at different strain rates for prestressing steel (A 421-65,  $f_{0.2, 20^{\circ}\text{C}} = 1470$  MPa). Anderberg (1983)



a)



b)

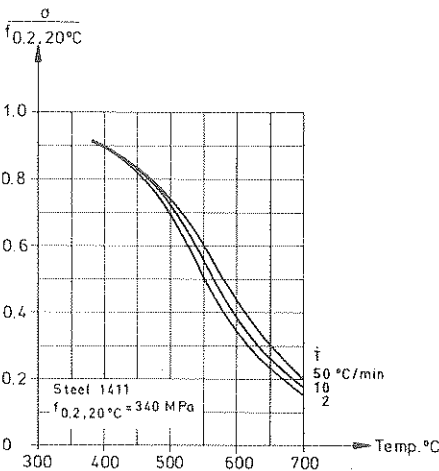

c)

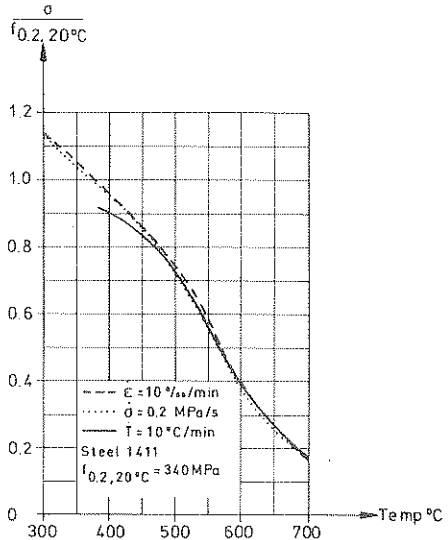

d)

Fig 38 Predicted ultimate strength versus temperature for structural steel.

- a) Steady state, stress rate controlled
- b) Steady state, strain rate controlled
- c) Transient state
- d) Comparison between steady state and transient state

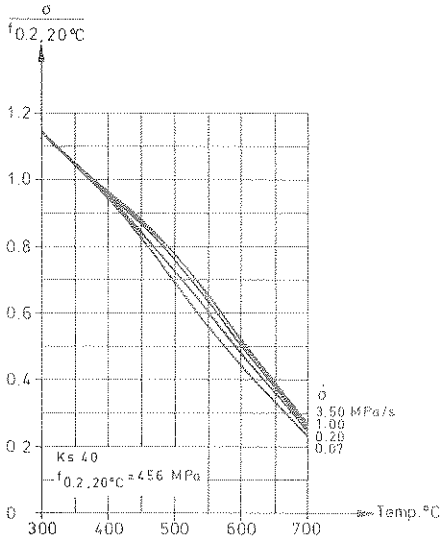

a)

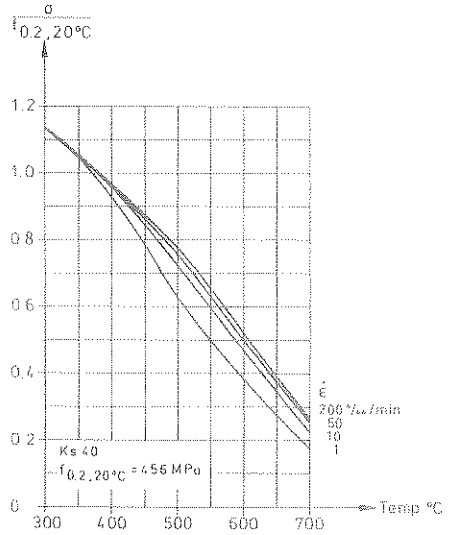

b)

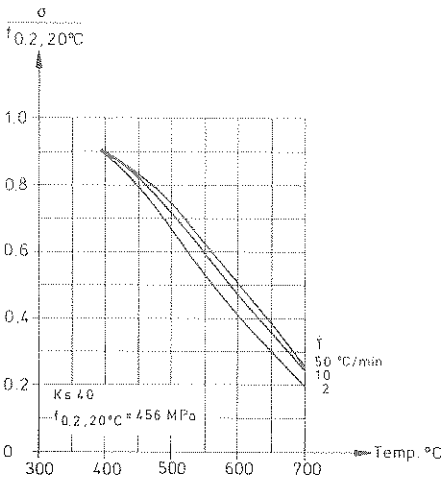

c)

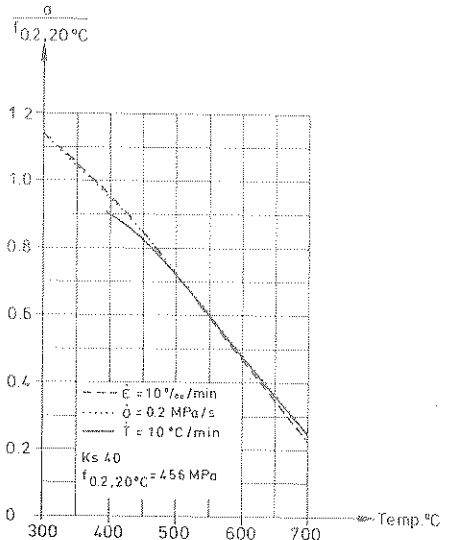

d)

Fig 39 Predicted ultimate strength versus temperature for reinforcing steel.

- a) Steady state, stress rate controlled
- b) Steady state, strain rate controlled
- c) Transient state
- d) Comparison between steady state and transient state

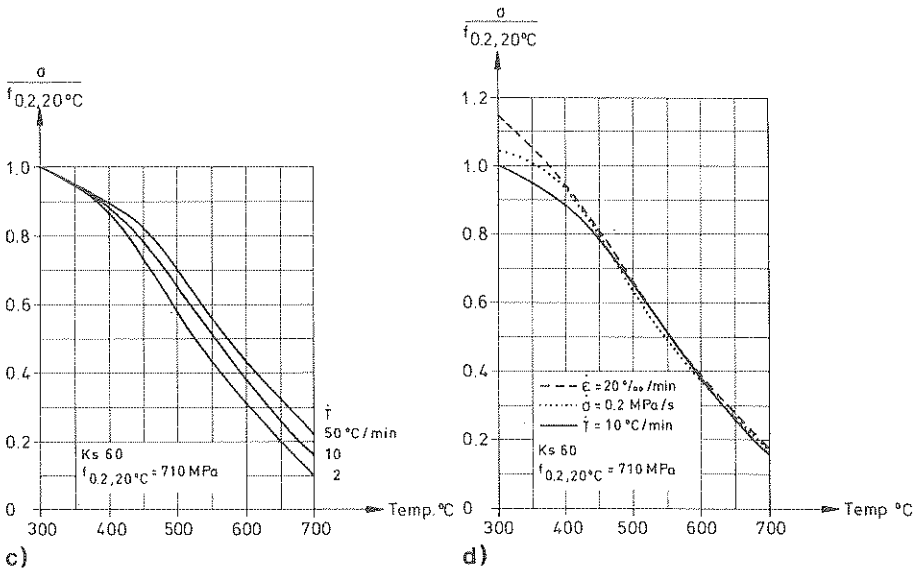
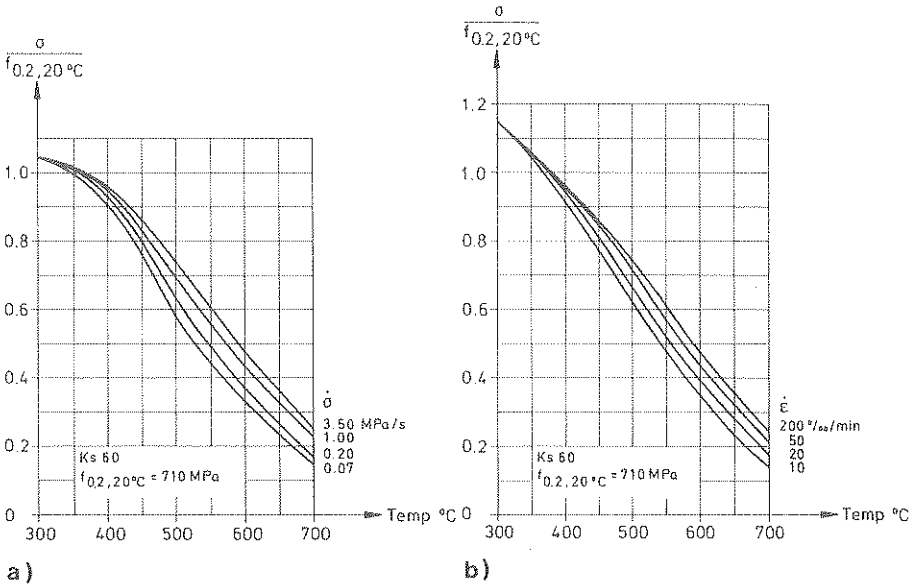
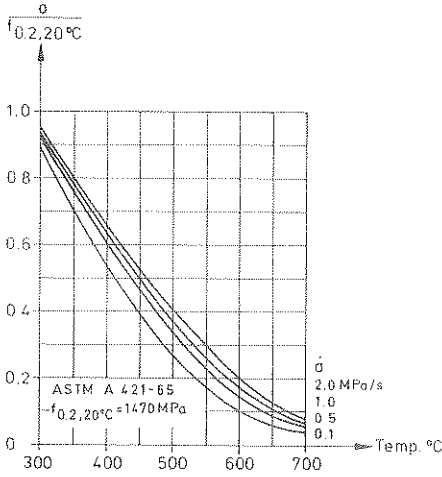
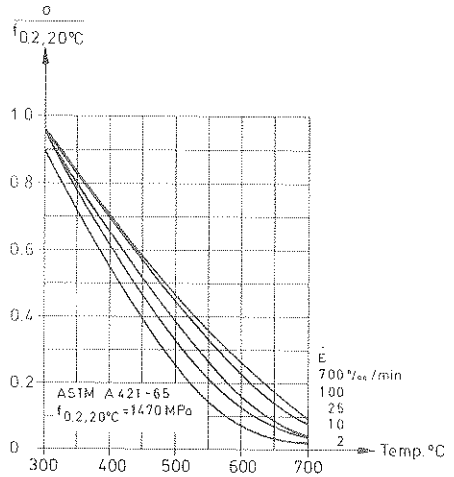

Fig 40 Predicted ultimate strength versus temperature for reinforcing steel.

- a) Steady state, stress controlled
- b) Steady state, strain controlled
- c) Transient state
- d) Comparison between steady state and transient state



a)



b)

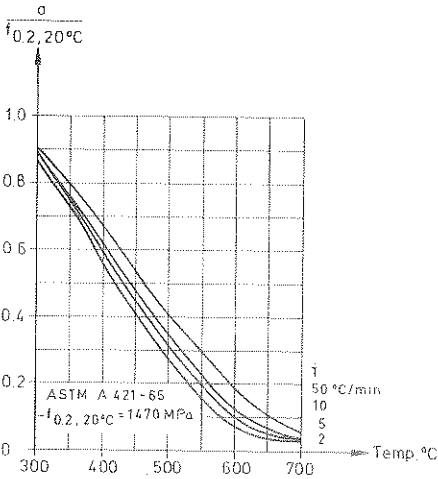

c)

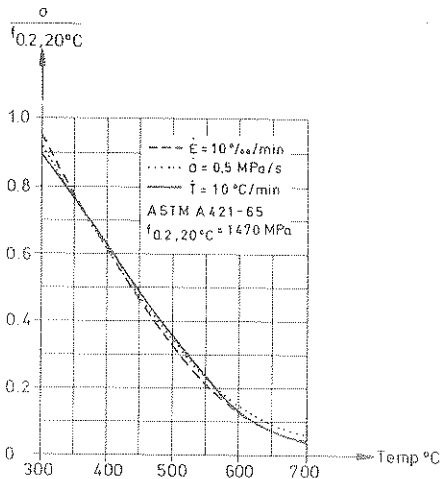

d)

Fig 41 Predicted ultimate strength versus temperature for prestressing steel.

- a) Steady state, stress rate controlled
- b) Steady state, strain rate controlled
- c) Transient state
- d) Comparison between steady state and transient state

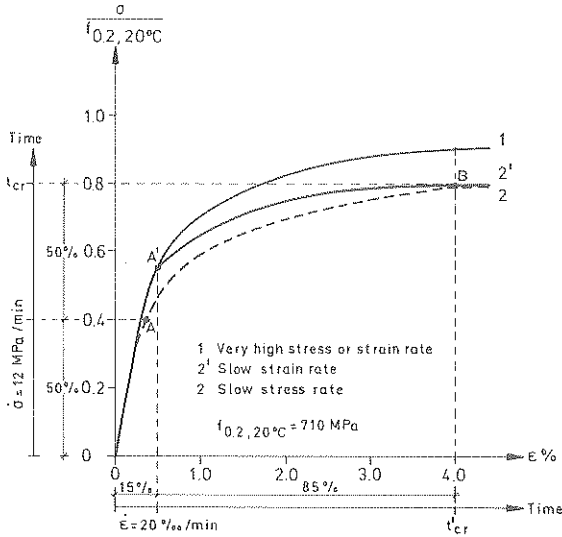

Fig 42 Principal  $\sigma$ - $\epsilon$  curves in stress and strain rate controlled steady state tests with time scales indicated ( $t'_{cr}$  and  $t_{cr}$  represent the testing period).



Part III: STEEL LITERATURE

6 References

6.1 Particular properties

6.1.1 General properties

6.1.2 Tensile strength

6.1.3 Modulus of elasticity

6.1.4 Thermal strain

6.1.5 Creep strain

6.1.6 Stress-strain characteristics

6.1.6.1 Steady state tests

6.1.6.2 Transient tests

6.1.7 Compressive strength

6.1.8 Relaxation

6.1.9 Thermal properties

6.1.10 Residual properties after cooling

6.2 Structural behaviour

6.3 Analytical models

6.3.1 Material

6.3.2 Structures

Subheadings

a) Structural steel

b) Reinforcing steel

c) Prestressing steel

d) Cast iron

e) Insulation material for steel protection

6.1 PARTICULAR PROPERTIES

6.1.1. General properties Additional headings  
a) Structural steel

Andrews, C.W.: Verhalten des Stahls bei erhöhten Temperaturen (Behaviour of steel at high temperatures) Stahl und Eisen (73), (1953).

Copier, W.Y.: Kruip van staal bij brand (Creep of steel during fire) Report No. BI-72-73/05.3. 6.1.3, 6.1.6.2, 11.640. Institute TNO for Building Materials and C 1 Building Structures, Delft, The Neatherlands, October 1972.

Diederichs, U., Ehm, C., Schneider, U.: Effect of temperature on steel and concrete for PCRV's. Technische Universität Braunschweig, 1981. 6.1.2, 6.1.3, 6.1.4, 6.1.6.1

Glen, J.: Elevated tensile, creep and rupture properties of various carbon steels. Proc. of Joint Conf. BISRA and ISI, Eastbourne (1966). 6.1.2, 6.1.5

Groenhaut, R., Knight, D., Skinner, D.H.: Steel properties for fire resistance. Melbourne Research Laboratories (MRL 6/1), May 1969. 6.1.2-6, 6.1.8, 6.1.9, 6.1.10

Gantwoort, G.J.: The mechanical properties of reinforcing and prestressing steel during and after fire. Institute TNO, Delft, The Neatherlands, Spetember 1979. 6.1.2-10 b and c

Harada, T., Furumura, F.: The behaviour of steel at high temperatures (in Japanese). Conseil International du Bâtiment. (CIB/CTF 67/24).

6.1 PARTICULAR PROPERTIES

6.1.1. General properties	Additional
a) Structural steel	headings
Harmathy, T.Z., Stanzak, W.W.: Elevated temperatures tensile and creep properties of some structural and prestressing steels. Nat. Res. Council Canada. Res. Paper 424 of Div. Bldg Res. NCR 11163, Ottawa 1970.	6.1.1, 6.1.2, 6.1.5, 6.1.6.1 a and c
Harmathy, T.Z.: Deflection and failure of steel supported floors and beams in fire. ASTM No. 422 C 2 1967.	6.1.3-5,
Harris, G.T.: Verhalten des Stahles bei erhöhten Temperaturen (Behaviour of steel at elevated temperatures). Stahl und Eisen (75), H.3, (1955)	
Knight, D.C.: Evaluation of the behaviour of steel in fires, Melbourne Research Laboratories, June 1971.	6.1.2
Reichel, V.: Behaviour of building steels at elevated temperatures. The Building Research Institute, Prag, Pers. Mitteilung.	6.1.2-6, 6.1.8, 6.1.10
Ritter, J.C., McPherson, R.: Anisothermal stress relaxation in a carbon-manganese steel. Journal of the Iron and Steel Institute, October 1970, pp 935-941.	6.1.2, 6.1.3, 6.1.5, 6.1.8
Ruge, J., Winkelmann, O.: Deformation behaviour of reinforcing and structural steel at high temperatures. Sonderforschungsbereich 148, Brandverhalten von Bauteilen, Arbeitsbericht 1978, 80 pp 147-192, Part II, Braunschweig, June 1980.	6.1.3c, 6.1.4c, 6.1.6b, c, 6.1.10b
Ros und Eichinger: Festigkeitseigenschaften der Stähle bei hohen Temperaturen (Strength of steel at high temperatures). EMPA, Bericht Nr. 138, Zürich (1941).	

6.1 PARTICULAR PROPERTIES

6.1.1. General properties	Additional headings
a) Structural steel	
Saito, H.: Fire resistance design for steel structures, BRI Research Paper No. 53, Building Research Institute 1972.	6.1.2, 6.1.3, 6.1.6.1
Saito, H.: Fire resistance design for steel structures, Building Research Institute, May 1976.	6.1.2, 6.1.3, 6.1.10
Simmons, W.F., Cross, H.C.: Elevated temperature properties of carbon steels, ASTM STP 180, 1955.	
Skinner, D.H.: Measurement of high temperature properties of steel, Melbourne Research Laboratories (MRL 6/10), May 1972.	6.1.2-6, 6.1.9
Skinner, D.H.: Behaviour of steel during fires, Melbourne Research Laboratories, May 1972.	
Skinner, D.H.: Mechanical behaviour of steel during fires, Melbourne Research Laboratories, November 1974.	
Stirland, C.: Steel properties at elevated temperatures for use in fire engineering calculations, Document ISO/TC92/WG15/No. 14, September 1980.	6.1.3, 6.1.4, 6.1.6.1, 6.1.9
Oding, I.A.: Strength of steels, ONTI, Moscow-Leningrad, 1937.	
Witteveen, J., Twilt, L.: Bijlaard, F.S.K.: The stability of braced and unbraced frames at elevated temperatures, Institute TNO for Building Materials and Building Structures, Delft 1977.	

6.1. PARTICULAR PROPERTIES

6.1.1. General properties

Additional  
headings

a) Structural steel

Zenkov, N.I.: Change of building steels strength under exposure of high temperatures, Industry Building, N11, 1957.

Zenkov, N.I.: Building materials and its behaviour in condition of fire, High Fire-Technical USSR School, Moscow, 1974.

Welter, G.: Elastizität und Festigkeit von Spezialstählen bei hohen Temperaturen (Elasticity and strength of special steels at high temperatures). Forschungsarbeiten auf dem Gebiete des Ingenieurwesens, Verlag des Vereins Deutscher Ingenieure, H. 230, Berlin (1921). 6.1.2,  
6.1.3,  
6.1.6.1

FIP/CEB Recommendations for the design of reinforced and prestressed concrete structural members for fire resistance, Guides to good practice, 1975. 6.1.1 b  
and c

FIP/CEB Report on methods of assessment of the fire resistance of concrete structural members, 1978. 6.1.1 b  
and c

b) Reinforcing steel

Anderberg, Y.: Mechanical properties of reinforcing steel at elevated temperatures (Armeringsståls mekaniska egenskaper vid höga temperaturer), In Swedish with English Summary, Tekniska meddelande nr 36, Halmstad Järnverk AB, Lund 1978. 6.1.2-6.1.6  
6.3

Bannister, J.: Steel reinforcement and tendons for structural concrete, Concrete July-August 1968.

6.1 PARTICULAR PROPERTIES

6.1.1. General properties

Additional  
headings

b) Structural steel

Bannister, J.L.: Steel reinforcement and tendons for structural steel, University College Cardiff, Concrete, July 1968.

Lancaster, R.I.: Steel reinforcement, Structural Concrete, Vol. 3 No. 4, July-August 1966.

Milovanov, A.F.: Influence of temperature on physico-technical properties of concrete and reinforcement and fire resistance of reinforced concrete constructions, Proceedings of V Congress FIP, Cement and Concrete Association, London 1968.

Woodman, G.D., Copeland, W.R.: The behaviour of reinforcing steels at elevated temperatures, J. Instn. Engrs. Aurt., 38(3), 53-9, 1966.

c) Prestressing steel

Abrams, C.: The behaviour at high temperature of steel strands for prestressed concrete, Bulletin 134 of the Research Department of the PCA, Skokie, Illinois, USA, 1961.

Bannister, J.: Steel reinforcement and tendons for structural concrete, Concrete, July-August 1968.

Baus, Brenneisen, K., Langueville: Contribution 6.1.2 c à l'étude du comportement au feu du béton précontraint (Contribution to the study of prestressed concrete structures), Université de Liège, 1968.

6.1 PARTICULAR PROPERTIES

6.1.1. General properties

c) Prestressing steel

Bates, S.C.C., u. Corson, R.H.: Effect of temperature on prestressing wires, Conference on Prestressed Concrete Pressure Vessels, Inst. Civil Engineers, 1968. Also in Institution of Civil Engineers, Conference on Prestressed Concrete Pressure Vessels, Proceedings, 1967.

Brenneisen, K.: Résultats au feu des armatures de précontrainte (Results of heating prestressing steel), Université de Liège, 1978.

Cahill, T.: The behaviour of prestressing wire at elevated temperatures, Proc. of Symp. of Fire Resistance of Prestressed Concrete at Braunschweig, 1965.

Cornish, R.C., Stevens, A.G., Skinner, S.H.: Short term creep and tensile data on AS A82 wire, BHP Report No. MRL/6/6.

Harmathy et al - see 6.1.1 a.

Ruge, J., Winkelmann, O. - see 6.1.1 a.

d) Insulation material for steel protection

Homer, R.D.: The protection of cold-formed structural elements against fire.

6.1. PARTICULAR PROPERTIES

6.1.2. Tensile strength

Additional  
headings

a) Structural steel

Boué, P.: Das Verhalten von Stahl und Stahlkonstruktionen bei Temperaturen, wie sie im Brande auftreten (Behaviour of steel and steel structures at elevated temperatures). Der Feuerschutz im Stahlhochbau - insbesondere Stahlstützen. D. Ausschusses für Stahlbau H21.

Fritsch, G., Siegel, R.: Kalt- und Warmfliesskurven von Baustählen (Yield curves of structural steel at high temperatures), Zentralinstitut für Fertigungstechnik des Maschinenbaus, Karl-Marx-Stadt (1965).

Glen, J. - see 6.1.1 a.

Groenhaut et al - see 6.1.1 a.

Gantwoort - see 6.1.1 a.

Harmathy et al - see 6.1.1 a.

Holmes, R., Pook, L.P.: Plain fatigue strength of a carbon manganese steel at elevated temperatures, National Engineering Laboratory, NEL Report No. 583 East Kilbride (1974).

Jörgensen et al - see 6.1.6.1 a.

Klippstein, K.H. - see 6.3.2.

6.1.3,  
6.1.6.1

Knight, D.C. - see 6.1.1 a.

Kosiorek, M.: The effect of high temperature on the basic mechanical properties, Institute of Building Technology, Warsaw, 1979. 6.1.3 a and c



6.1. PARTICULAR PROPERTIES

6.1.2. Tensile strength Additional  
a) Structural steel headings

Miller, R.F.: The strength of carbon steels for elevated temperature applications, ASTM (54), Proceedings (1954).

Reichel, V. - see 6.1.1 a.

Ritter, J.C. et al - see 6.1.1 a.

Ros, Eichinger - see 6.1.1 a.

Saito, H. - see 6.1.1 a.

Skinner, D.H., Knight, D.C.: Elevated temperature tensile properties of AS A151, October 1971, Melbourne Research Laboratories.

Skinner, D.H. - see 6.1.1 a.

Skinner et al - see 6.1.1 a.

Smith, A.J., Jenkinson, D.J., Armstrong: Creep 6.1.5  
and rupture properties of carbon steels,  
Proceedings, Inst. of Mechanical Engineers,  
Vol. 174 (1960).

Smith, G.V.: Evaluation of the elevated temperature tensile and creep-rupture properties of 1/2 Cr-1/2 Mo, 1 Cr-1/2 Mo and 1 1/4 Cr-1/2 Mo-Si steels, ASTM, DS50, September 1973.

Stevens, A.G., Cornish, R.C., Skinner, D.H.:  
Tensile data on four structural steels, November 1971, Melbourne Research Laboratories.

Welter, G. - see 6.1.1 a.

White, A.E., Clarke, C.L., Wilson, R.L.: The fracture of carbon steels at high temperatures, Americ. Soc. Metals, Transactions (25) (1937).

6.1. PARTICULAR PROPERTIES

6.1.2. Tensile strength

b) Reinforcing steel

Anderberg, Y. - see 6.1.1 b.

Dannenber, J.: Festigkeitsuntersuchung des Bewehrungsstahls bis 600°C (Strength investigation of reinforcing steel up to 600°C), DAFStB, H. 132, Ernst & Sohn, Berlin (1959).

Gantwoort, G.J. - see 6.1.1 a.

Skinner, D.H.: Fire resistance of hot rolled and cold worked steels, April 1971.

c) Prestressing steel

Day, M.F., Jenkinson, E.A., Smith, A.I.: Effect of elevated temperatures on high tensile wires for prestressed concrete, Proc. Inst. Civil Eng. Vol. 16 May 1969, pp 55-70.

Harmathy, T.Z. et al - see 6.1.1 a.

Marks, G., Watson, J.D.: High temperature strengths of some deformed bars, October 1972, Melbourne Research Laboratories.

Rehn et al - see 6.1.6.1 c.

Voves, B.: Behaviour of prestressed concrete structures during fire, Czech Technical University, Prague, Czechoslovakia.

FIP/CEB - see 6.1.1 a.

6.1. PARTICULAR PROPERTIES

6.1.2. Tensile strength

d) Cast iron

Davies, V. de L.: Stress-rupture testing of Aluminium - 1% Nickel - 0.5% Iron Alloy, Journal of Institute of Metals, Vol. 89 1960-61, SINTEF, Trondheim, Norway.

Davies, V. de L., Bakken, K.: Stress-rupture testing of extended hypoeutectic aluminium-silicon-magnesium-nickel alloys, Journal of Nuclear Materials, Vol. 13 No. 1, SINTEF, Trondheim, April 1964, Norway.

Davies, V. de L., Bakken, K.: High temperature low cycle fatigue of an extended aluminium-magnesium-nickel alloy, SINTEF, Trondheim, September 1965, Norway.

6.1. PARTICULAR PROPERTIES

6.1.3. Modulus of elasticity

Additional  
headings

a) Structural steel

Garofolo, E., Malenock, P.R., Smith, G.V.: The influence of temperature on the elastic constants of some commercial steels - Determination of elastic constants, ASTM Special Technical Publication (STP) 129 (1952).

Groenhaut, et al - see 6.1.1a.

Gantwoort, G.J. - see 6.1.1a.

Jørgensen et al - see 6.1.6.1a.

Klippstein, K.H. - see 6.3.2

6.1.2, 6.1.6.1

Kosiorek, M. - see 6.1.1a.

Lea, F.C., Crowther, O.H.: The change of the modulus of elasticity and of other properties of metals with temperature, Engineering, Vol. 98, 1914, p. 487.

Reichel, V. - see 6.1.1a.

Ritter, J.C. et al - see 6.1.1a.

Ros, Eichinger - see 6.1.1a.

Saito, H. - see 6.1.1a.

Stirland - see 6.1.1a.

Welter, G. - see 6.1.1a.

Verse, G.: The elastic properties of steel at high temperatures, Transactions American Society of Mechanical Engineers, Vol. 57, 1935, p. 1.

6.1. PARTICULAR PROPERTIES

6.1.3. Modulus of elasticity

b) Reinforcing steel

Anderberg, Y. - see 6.1.1b.

Gantwoort, G.J. - see 6.1.1a.

c) Prestressing steel

Reichel, V. - see 6.1.1c.

Ruge, J., Winkelmann, O. - see 6.1.1a.

6.1. PARTICULAR PROPERTIES

6.1.4. Thermal strain

a) Structural steel

Groenhaut et al - see 6.1.1a.

Reichel, V. - see 6.1.1a.

Skinner, D.H. - see 6.1.1a.

Stirland, C. - see 6.1.1a.

b) Reinforcing steel

Anderberg, Y. - see 6.1.1b.

c) Prestressing steel

Ruge, J., Winkelmann, O. - see 6.1.1a.

6.1. PARTICULAR PROPERTIES

6.1.5. Creep strain

a) Structural steel

Dorn, J.E.: Some fundamental experiments on high temperature creep, Journal of the Mechanics and Physics of Solids, Vol. 3 (1954).

Dorn, J.E.: Progress in understanding high temperature creep, Guillet Memorial Lecture, ASTM 1962.

Glen, J. - see 6.1.1a.

Groenhaut et al - see 6.1.1a.

Gantwoort, G.J. - see 6.1.1a.

Harmathy et al - see 6.1.1a.

Jørgensen et al - see 6.1.1a.

Knight et al - see 6.3.1

Reichel, V. - see 6.1.1a.

Ritter et al - see 6.1.1a.

Skinner, D.H. - see 6.1.1a.

Skinner, D.H., Stevens, A.G.: Anisothermal creep of fire steels, May 1972, Melbourne Research Laboratories.

Skinner, D.H., Stevens, A.G., Marks, G.L.: Fire resistance properties of three steels, March 1973, Melbourne Research Laboratories.

Skinner, D.H., Carnish, R.C., Toyama, M.: Parameters for short-term and anisothermal creep, April 1973, Melbourne Research Laboratories.

6.1. PARTICULAR PROPERTIES

6.1.5. Creep strain

a) Structural steel

Thor, J.: Investigation of creep properties of various types of structural steels exposed to fire (Undersökning av olika konstruktionsståls krypegenskaper under brandförhållanden, in Swedish), Jernkontorets forskning D40, Stockholm 1972.

b) Reinforcing steel

Anderberg, Y. - see 6.1.1b.

Reichel, V. - see 6.1.1a.

c) Prestressing steel

Harmathy et al - see 6.1.1c.



6.1. PARTICULAR PROPERTIES

6.1.6. Stress-strain characteristics

6.1.6.1 Steady state tests

Additional  
headings

a) Structural steel

Gantwoort, G.J. - see 6.1.1a.

Groenhaut et al - see 6.1.1a.

Harmathy et al - see 6.1.1a.

Jørgensen, J.R., Sørensen, A.H.: Mechanical 6.1.2,  
properties of structural steel at elevated 6.1.3,  
temperatures, Institute of Building Technology 6.1.5,  
and Structural Engineering, Aalborgs Universi- a  
tetscenter, July 1980.

Magnusson, S.E. - see 6.3.2.

Reichel, V. - see 6.1.1a.

Saito, H. (1972) - see 6.1.1a.

Skinner, D.H. (1972) - see 6.1.1a.

Stirland, C. (1980) - see 6.1.1a.

Teeside Laboratories: Elevated temperature tensile  
properties of structural steels manufactured by  
the British Steel Corporation, British Steel Corpo-  
ration, Report No. T/RS/11/80C, July 1980.

b) Reinforcing steel

Ruge, J., Winkelmann, O. - see 6.1.1a.

6.1. PARTICULAR PROPERTIES

6.1.6. Stress-strain characteristics

6.1.6.1 Steady state tests

c) Prestressing steel

Dannenberg, Deutschmann, Melchiour: Warmzerreissversuche mit Spannstählen (Tensile strength of prestressing steels at high temperatures) DAFStB, Heft 122, Ernst & Sohn, Berlin (1957).

Gantwoort, G.J. - see 6.1.1a.

Harmathy et al - see 6.1.1c.

Rehm, G, Nürnberger, U.: Zur Frage der Dauerhaltbarkeit von Spannstählen (Mitteilung des Lehrstuhls für Werkstoffe im Bauwesen am Otto-Graf-Institut der Universität Stuttgart) (On the question of duration of stability of prestressing steels), Betonwerk + Fertigteil-Technik, Heft 9 (1976)

Ruge, J., Winkelmann, O. - see 6.1.1a.

6.1.6.2 Transient tests

a) Structural steel

Copier, W.J. - see 6.1.1a.

Ehm, H., Witteveen, J.: Die kritische Temperatur bei hochtemperaturbeanspruchten Bau- und Betonstählen (The critical temperature for high temperature stressed structural and reinforcing steel), Stahlbau, H. 11 (1970).

Gantwoort, G.J. - see 6.1.1a.

Ruge, J., Winkelmann, O.: Method for the determination of a critical value in case of instationary heating when simulating the influence of fire on steel (in German), Materialprüf. 19 (1977), No. 8 August.

6.1. PARTICULAR PROPERTIES

6.1.6. Stress-strain characteristics

6.1.6.2 Transient tests

a) Structural steel

Witteveen, J.: Brandveiligheid Staalconstructies (Fire resistance of steel structures), Centrum Bouwen in Staal, Rotterdam 1966.

Witteveen, J., Twilt, L.: On the behaviour of steel columns at elevated temperatures, Colloquium on Column Strength, Paris 1972.

b) Reinforcing steel

Ruge, J., Winkelmann, O.: Deformation behaviour of concrete and prestressing steels at high temperatures, Sonderforschungsbereich 148, Brandverhalten von Bauteilen, Arbeitsbericht 1975-77, pp B4.1-56, Part II, Braunschweig, July 1977.

Soretz, S.: Tor-Stahl bei Brandtemperaturen (Tor steel on fire conditions), Schweizer Archiv, Heft 1, 1955.

Soretz, S.: Fatigue behaviour of high yield steel reinforcement, Concrete and Constructional Engineering, July 1965.

Soretz, S.: Tensile tests on reinforcing steel under sustained load and increasing temperature, Tor-Islog Steel Corporation, Luxemburg, Vienna, Vol. 31 (1967).

c) Prestressing steel

Jäniche, W., Wascheidt, H.: Warmkriechversuche an Spannstählen (Load controlled transient tests on prestressing steels at high temperature), FIP-Commission on Fire Resistance of prestressed concrete (Juni 1965)

Voves, B. - see 6.1.2c.

6.1. PARTICULAR PROPERTIES

6.1.7. Compressive strength

a) Structural steel

Ingberg, S.H., Sale, P.D.: Compressive strength and deformation of structural steel and cast iron shapes at temperatures up to 950°C, Proceedings, American Society for Testing and Materials, (26), Part III, Philadelphia (1926).

Sale, P.D.: Compressions-tests of structural steel at elevated temperatures, Journal of Research of the National Bureau of Standards, Vol. 13 (1934).

De Falco, F.D.: Investigation of the compressive response of modern structural steels at fire load temperatures, University of Connecticut, 1974 (Structural steel A36).

6.1. PARTICULAR PROPERTIES

6.1.8. Relaxation

a) Structural steel

Groenhaut, G.J. - see 6.1.1a.

Reichel, V. - see 6.1.1a.

Ritter et al - see 6.1.1a.

b) Reinforcing steel

Reichel, V. - see 6.1.1a.

c) Prestressing steel

Cahill, T., Branch, G.D.: Long term relaxation behaviour of stabilized prestressing wires and strands.

FIP: Concrete for fire resistance construction, a Cembureau report prepared with the assistance of FIP 1979.

Voves, B. - see 6.1.2c.

d) Cast iron

Davies, V. de L., Augland, B., Christensen, N.: Relaxation of pearlitic cast iron, Journal of the Iron and Steel Institute, Vol. 202, April 1964.

6.1. PARTICULAR PROPERTIES

6.1.9. Thermal properties

a) Structural steel

Alpsten, G.: Egenspänningar i varmvalsade stålprofiler (Residual stresses in hot-rolled steel sections). Institutionen för brobyggnad, KTH, Stockholm, 1967 (In Swedish).

(conductivity of steel specific volumetric enthalpy MJ/m<sup>3</sup> TASEF)

Butler, I.: Thermal diffusivity of metals at elevated temperatures, USNRDL TR 177, pp 1 - 27, 1957 (AD 143 863).

Fink, K. et al: Physikalische Eigenschaften von Stählen, insbesondere von warmfesten Stählen (Physical properties of steel especially hot-rolled steel), Thyssenforschung 2. Jahrg. 1970, Heft 2.

Groenhaut et al - see 6.1.1a.

Lie, T.T., Stanzak, W.W.: Fire resistance of protective steel columns, National Research Council of Canada, Research Paper No. 574, Ottawa 1973.

Lindner, J., Stens, W.: Fire protection of buildings, Warsaw, 1974.

Pogorzelski, J.A.: Thermal properties of some building materials, Building Research Institute, Warsaw, Poland, 1979.

Richter, Fr.: Die wichtigsten physikalischen Eigenschaften von 52 Eisenwerkstoffen (The most important physical properties of 52 iron materials), Forschungsinstitut der Mannesmann AG, Verlag Stahleisen mbH, Düsseldorf, H. 8 (1973).

6.1. PARTICULAR PROPERTIES

6.1.9. Thermal properties

a) Structural steel

Schneider, U., Diederichs, U.: Physical properties of steel and concrete up to melting and ablation, Technical University of Braunschweig, 1981.

Sidles, Danielson: Thermal conductivity of metals at high temperatures, USA EC Report ISC-198, pp. 1-24, 1951.

Sidles: Thermal diffusivity of metals at high temperatures, USA EC Report TID-5185 (Rev.) (Del.), 110-6, 1953.

Skinner, D.H. - see 6.1.1a.

Stirland, C. - see 6.1.1a.

BISRA: Physical constants of some commercial steels at elevated temperatures, The British Iron and Steel Research Association, Butterworths Scientific Publications, London (1953).

C.T.I.C.M.: Prévision par le calcul du comportement au feu des structures en acier, recommandations établies par le C.T.I.C.M., Puteaux (France) - septembre 1975.

Wickström, U.: TASEF-2 - A computer program for temperature analysis of structures exposed to fire, Report No. 79-2, Lund Institute of Technology, Lund 1979.

6.1. PARTICULAR PROPERTIES

6.1.10. Residual strength

a) Structural steel

Gantwoort, G.J. - see 6.1.1a.

Groenhaut et al - see 6.1.1a.

Klingsch, W., Winkelmann, o.: Investigation of residual strength of reinforcing and structural steel exposed to fire, Sonderforschungsbereich 148, Brandverhalten von Bauteilen, Arbeitsbericht 1978-80, pp. 337-353, Part I, Braunschweig, June 1980.

Reichel, V. - see 6.1.1a.

Saito, H. - see 6.1.1a.

Smith, C.I. et al: The reinstatement of fire damaged steel framed structures, British Steel Corporation, Teeside Research Laboratories, Fire Safety Journal 4(1981).

b) Reinforcing steel

Winkelmann et al - see 6.1.1a.

Reichel, V. - see 6.1.1a.

c) Prestressing steel

Abrams, M.S., Erlin, B.: Estimating post-fire strength and exposure temperature of prestressing steel by a metallographic method, Bulletin 219 of the Research Department of the PCA, Skokie, Illinois, 1967.



6.1. PARTICULAR PROPERTIES

6.1.10. Residual strength

c) Prestressing steel

FIP/CEB - see 6.1.1a.

6.2. STRUCTURAL BEHAVIOUR

Hoffend, F.: Behaviour of fire-exposed steel columns with eccentric load, axial restraint and partly insulated, Sonderforschungsbereich 148, Brandverhalten von Bauteilen, Arbeitsbericht 1978-80, pp. 29-59, Part I, Braunschweig, June 1980.

Hoffend, F.: Fire tests of steel frames - Experimental and theoretical study, Sonderforschungsbereich 148, Brandverhalten von Bauteilen, Arbeitsbericht 1978-80, pp. 61-78, Part I, Braunschweig, June 1980.

Witteveen, J., Twilt, L., Bijlaard, F.S.K.: The stability of braced and unbraced frames at elevated temperatures, Institute TNO, Liège 1977.

6.3. ANALYTICAL MODELS

6.3.1. Material behaviour

Anderberg, T. - see 6.1.1b.

Anderberg, Y.: Fire behaviour of steels and concrete structures. Presented at the seminar on Three decades of structural Fire Safety at FRS in Borehamwood. Lund Institute of Technology, 1983.

Anderberg, Y.: Modelling steel behaviour. Presented at the international conference on "Design of structures against fire" at Aston University, April 1986.

Copier, W.J. - see 6.1.1a.

Dorn, J.E.: Some fundamental experiments on high temperature creep, Journal of the mechanics and Physics of Solids, Vol. 3, 1954.

Gantwoort, G.J. - see 6.1.1a.

Harmathy, T.Z.: A comprehensive creep model, National Research Council of Canada, Research Paper No. 324, Ottawa 1967.

Knight, D., Skinner, D.H., Lay, M.G.: Prediction of isothermal creep, Melbourne Research Laboratories, April 1971.

Plem, E.: Theoretical and experimental investigations of point set structures, Swedish Council for Building Research, Document D9:1975.

6.3. ANALYTICAL MODELS

6.3.2. Structural behaviour

Anderberg, Y.: Fire-exposed hyperstatic concrete structures - An experimental and theoretical study, Bulletin No. 55, Lund Institute of Technology, Lund 1976.

Anderberg, Y., Forsén, N.E.: Fire Resistance of concrete structures. Nordic Concrete Research, No. 1, 1983.

Von Beer, G.: Nichtlineare Temperaturspannungsbe-  
rechnung mit Hilfe der Finite-Element-Methode  
unter besonderer Rücksichtnahme auf extreme Hitze-  
einwirkung (Non-linear temperature and stress cal-  
culation with FEM at elevated temperatures), Der  
Stahlbau 9(1976).

Eslami, M.R.: Creep relaxation of a beam of gene-  
ral cross section, subjected to mechanical and  
thermal loads, Journal of Mechanical Design, Trans-  
actions of the ASME Vol 100, October 1978.

Forsén, N.E.; STEELFIRE. Finite element program for  
nonlinear analysis of steel frames exposed to fire.  
Multiconsult AS, Oslo 1983.

Harmathy, T.Z.: Deflection and failure of steel  
supported floors and beams in fire, National Research  
Council of Canada, Division of Building Research,  
Paper No. 193, Ottawa 1966.

Harmathy, T.Z.: Creep deflection of metal beams in  
a transient heating process, with particular refe-  
rence to fire, National Research Council of Canada,  
Division of Building Research, Paper No. 673, Ottawa  
1976.

- 6.3. ANALYTICAL MODELS Additional  
6.3.2. Structural behaviour headings

Kruppe, J.: Collapse temperature of steel structures, Journal of the Structural Division, pp. 1769-1788, September 1979.

Lie, T.T.: Fire resistance of structural steel, Engineering Journal No. 15, pp. 116-125, 1978, American Institute of Steel Construction.

Magnusson, S.E.: Stålpelares verkningssätt och bärförmåga vid brand (Mode of action and load-bearing capacity of steel columns) in Swedish, Lund Institute of Technology, Lund 1979. 6.1.6.1

Pogorzelski, J.A.: Recommendations for calculating the fire resistance of steel structures, Warsaw 1979.

Smith, C.I.: The fire resistance of unprotected steel beams, Document ISO/TC92/W15 No. 13, September 1980.

Stanzak, W.W., Lie, T.T.: Fire resistance of unprotected steel columns, Journal of the Structural Division, ASCE, Vol. 99, No. ST5, May 1973.

Thor, J.: Statiskt bestämda stålbalkars deformation och bärförmåga vid brandpåverkan - Experimentell och teoretisk undersökning (Deformation and loadbearing capacity of fire-exposed steel beams - An experimental and theoretical investigation), Swedish Steel Institute, Report 22:9, Stockholm 1972.

7 Symbols and abbreviations

$c_p$	specific heat	$\text{kJ/kg}^\circ\text{C}$
$I$	specific volumetric enthalpy	$\text{MJ/m}^3$
$\lambda$	thermal conductivity	$\text{W/m}^\circ\text{C}$
$E_{20^\circ\text{C}}$	modulus of elasticity at room temperature	
$E_T$	---	temperature T
$f_{0.2, 20^\circ\text{C}}$	0.2 % proof stress at room temperature	
$f_{0.2, T}$	---	temperature T
$f_{u, 20^\circ\text{C}}$	ultimate strength at room temperature	
$f_{u, T}$	---	temperature T
$t$	time	(h, s)
$T$	temperature	$^\circ\text{C}$
$\dot{T}$	rate of heating	$^\circ\text{C/min}$
$\epsilon$	strain	
$\dot{\epsilon}$	rate of strain	$\text{s}^{-1}$
$\epsilon_{th}$	thermal strain	
$\epsilon_\sigma$	stress-related strain	
$\epsilon_{ct}$	creep strain	
$\sigma$	stress	MPa
$\dot{\sigma}$	rate of stress	MPa/s

