

Title	Proposal of Hydrogen Blistering Mechanism Associated with Disbonding between 2 · 1/4Cr-1Mo Steel and Type 309 Overlaid Metal
Author(s)	Matsuda, Fukuhisa; Nakagawa, Hiroji; Tsuruta, Sanae
Citation	Transactions of JWRI. 15(2) P.379-P.380
Issue Date	1986-12
Text Version	publisher
URL	http://hdl.handle.net/11094/5363
DOI	
rights	本文データはCiNiiから複製したものである
Note	

Osaka University Knowledge Archive : OUKA

<https://ir.library.osaka-u.ac.jp/>

Osaka University

Proposal of Hydrogen Blistering Mechanism Associated with Disbonding between 2.1/4Cr-1Mo Steel and Type 309 Overlayed Metal

Fukuhisa MATSUDA *, Hiroji NAKAGAWA ** and Sanae TSURUTA ***

KEY WORDS: (Austenitic Stainless Steel) (Heat Resistant Materials) (Hydrogen Embrittlement) (Cracking)

It has been widely said that the disbonding between 2.1/4 Cr-1Mo steel and type 309 overlayed metal which occurs during shutdown period of desulfurizing reactor is caused by very high hydrogen accumulation at the bonding interface and residual stress.¹⁾ The authors, however, have shown²⁾ in simulated disbonding test utilizing electrolytic hydrogen charge that thinning the thickness of 2.1/4Cr-1Mo steel makes the disbonding severer. This implies that the residual stress has not so much effect on the disbonding. On the other hand, the maximum hydrogen content at the bonding interface is shown to reach about 300 ppm during the shutdown period.³⁾ Well, it is well known⁴⁾ in the field of hydrogen induced cracking (HIC) in carbon steel that such high content of hydrogen is enough to cause blistering that occurs generally at the interface between matrix and inclusion. Therefore, the authors have tried to study if the similar mechanism would act on the disbonding.

Mainly type 309 and partly 308 overlayed metal were made by submerged-arc strip-cladding process on 2.1/4Cr-1Mo steel of 115 mm thickness. The welding conditions were welding current of 1200 A, arc voltage of 27 V and welding speed of 2.5 mm/sec. After the welding, the welds were heat-treated under the condition of 690°C × 24 hrs. The chemical compositions and the microstructures of the weld are shown elsewhere.²⁾

Disbonding test was done by electrolytic hydrogen charging technique and autoclave. For the electrolytic hydrogen charging test, tapered specimen shown in Fig. 1 was used. The specimen was set to the small electrolytic vessel shown in Fig. 2 that was designed so as to be mounted on the stage of optical microscope. Glycerine was applied on the top surface, and the bubbling of hydrogen gas and the blistering were observed through microscope. The Electrolyte used was aqueous solution of 5% sulfuric acid to which phosphorus was added. Current density used was 0.1 A/cm².

The specimen configuration for autoclave testing is shown in Fig. 3. The surface of overlayed metal was ground

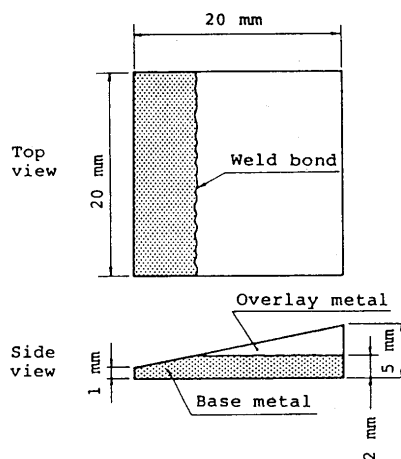

Fig. 1 Specimen configuration for direct observation of hydrogen gas bubbling and blistering with electrolytic hydrogen charge.

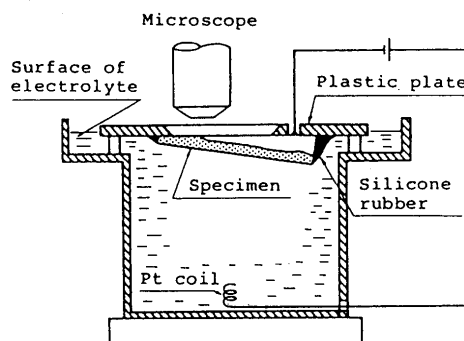

Fig. 2 Direct observation technique during electrolytic hydrogen charge.

to the thickness of 0.5, 1.0 and 1.5 mm to make the blistering noticeable, if it occurred. The conditions of autoclave were hydrogen pressure of 220 kgf/cm², temperature of 450°C, holding time of 48 hr and cooling rate of about 350°C/hr to minimize the escape of hydrogen through thin overlayed metal.

During electrolytic hydrogen charging test, the bubbling of hydrogen gas was detected in HAZ at first, and the bubbling position moved gradually toward the bonding

† Received on Nov. 5, 1986

* Professor

** Research Instructor

*** with Nippon Steel Corp.

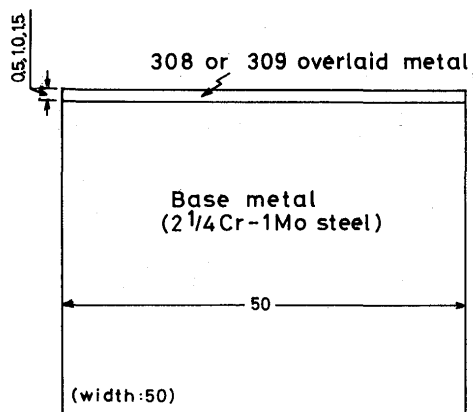

Fig. 3 Specimen configuration for the test in autoclave.

interface, coinciding the change in the thickness. After about 50 min from the start, the bubbling was observed at the tip of carbide layer in the overlaid metal that was highly hardened zone. In the region composed of austenite and several percent of delta, however, no bubbling was observed even after six hour and even near the carbide layer. Instead the blistering was observed from about 3 hr as shown in Fig. 4.

Similar phenomenon of blistering was also observed in the specimen tested by autoclave. An example is shown in Fig. 5. The maximum height of the blistering was about

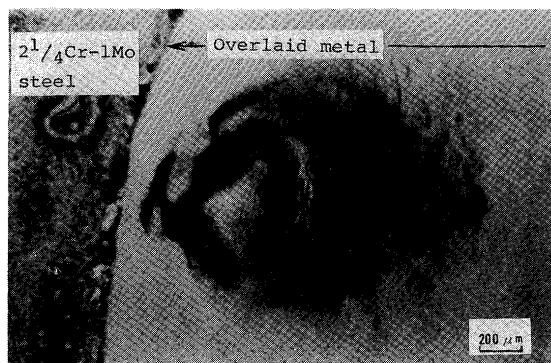

Fig. 4 Blistering in overlaid metal near carbide layer during electrolytic hydrogen charge.



Fig. 5 Example of blistering occurred after autoclave test. The thickness of overlaid metal: 0.5 mm.

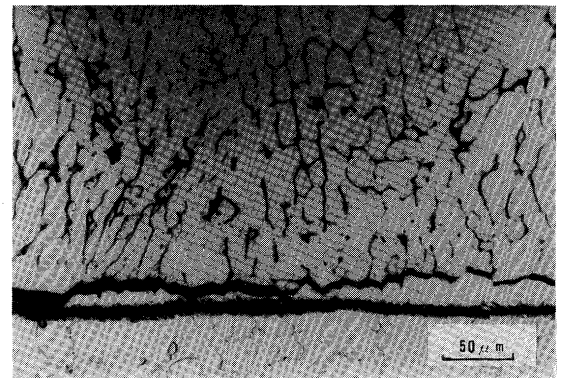

Fig. 6 Microstructure near disbonding associated with blistering.

0.08 mm in the specimen which had overlaid metal of 0.5 mm thickness. Figure 6 shows the microstructures around the disbonding associated with the blistering, which gives the same feature as that in usual testing.¹⁾

Both Figs. 4 and 5 strongly suggests that very high pressure of hydrogen gas causes the disbonding. The maximum hydrogen content accumulated at the bonding interface during the shutdown reaches about 300 ppm as mentioned. This equilibrates with about 60,000 MPa of hydrogen gas according to Sievert's law.⁵⁾ Of course, this pressure may be overestimated because fugacity correction⁶⁾ was not done. Nevertheless, this estimation means that hydrogen gas once precipitated has sufficiently high pressure to cause blistering. This behavior is the same as hydrogen blistering in HIC in principle. The difference between them is that the hydrogen gas in the disbonding tends to occur at matrix-carbide interface along grain-boundary, while usual blistering in HIC occurs at matrix-inclusion interface irrespective grain-boundary.

Therefore, the authors would like to propose that hydrogen blistering mechanism must not be ignored in the problem of disbonding, although any blistering could not be observed so far in disbonding because of large thickness of overlaid metal.

The authors would like to thank Mitsubishi Heavy industries for the offering of materials used and the execution of autoclave.

References

- 1) K. Ohnishi: J. Japan Weld. Soc., 54 (1985), p. 154 (in Japanese)
- 2) F. Matsuda, et al.: Trans. JWRI, 13 (1984), p. 263.
- 3) K. Kinoshita: J. Japan Weld. Soc., 54 (1985), p. 330 (in Japanese).
- 4) A. Ikeda: J. Iron & Steel Inst. Japan, 70 (1984), p. 792 (in Japanese).
- 5) S. Nomura and M. Hasegawa: Bulletin of Japan Inst. Met., 15 (1976), p. 563 (in Japanese).
- 6) F. de Kazincy: Acta Met., 7 (1959), p. 525.