

## Prospective techno-economic and environmental assessment of carbon capture at a refinery and CO<sub>2</sub> utilisation in polyol synthesis

Fernández-Dacosta, Cora; Van Der Spek, Mijndert; Hung, Christine Roxanne; Oregonni, Gabriel David; Skagestad, Ragnhild; Parihar, Prashant; Gokak, D. T.; Strømman, Anders Hammer; Ramirez, Andrea

**DOI**

[10.1016/j.jcou.2017.08.005](https://doi.org/10.1016/j.jcou.2017.08.005)

**Publication date**

2017

**Document Version**

Final published version

**Published in**

Journal of CO<sub>2</sub> Utilization

**Citation (APA)**

Fernández-Dacosta, C., Van Der Spek, M., Hung, C. R., Oregonni, G. D., Skagestad, R., Parihar, P., Gokak, D. T., Strømman, A. H., & Ramirez, A. (2017). Prospective techno-economic and environmental assessment of carbon capture at a refinery and CO<sub>2</sub> utilisation in polyol synthesis. *Journal of CO<sub>2</sub> Utilization*, 21, 405-422. <https://doi.org/10.1016/j.jcou.2017.08.005>

**Important note**

To cite this publication, please use the final published version (if applicable).  
Please check the document version above.

**Copyright**

Other than for strictly personal use, it is not permitted to download, forward or distribute the text or part of it, without the consent of the author(s) and/or copyright holder(s), unless the work is under an open content license such as Creative Commons.

**Takedown policy**

Please contact us and provide details if you believe this document breaches copyrights.  
We will remove access to the work immediately and investigate your claim.

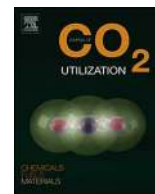

## Prospective techno-economic and environmental assessment of carbon capture at a refinery and CO<sub>2</sub> utilisation in polyol synthesis



Cora Fernández-Dacosta<sup>a,\*</sup>, Mijndert van der Spek<sup>a</sup>, Christine Roxanne Hung<sup>b</sup>, Gabriel David Oregioni<sup>b</sup>, Ragnhild Skagestad<sup>c</sup>, Prashant Parihar<sup>d</sup>, D.T. Gokak<sup>d</sup>, Anders Hammer Strømman<sup>b</sup>, Andrea Ramirez<sup>a,e</sup>

<sup>a</sup> Copernicus Institute of Sustainable Development, Utrecht University, Heidelberglaan 2, 3584 CS Utrecht, The Netherlands

<sup>b</sup> Industrial Ecology Programme, Department of Energy and Process Engineering, Norwegian University of Science and Technology, Trondheim, 7491, Norway

<sup>c</sup> Tel-Tek, Kjølnes ring 30, 3918, Porsgrunn, Norway

<sup>d</sup> Corporate Research and Development Centre, Bharat Petroleum Corporation Limited, Greater Noida, UP, 201306, India

<sup>e</sup> Department of Engineering, Systems and Services, Faculty of Technology, Policy and Management, Delft University of Technology Jaffalaan 5, 2628 BX Delft, The Netherlands

### ARTICLE INFO

#### Keywords:

Carbon capture and utilisation  
CO<sub>2</sub> economy  
CO<sub>2</sub>-based polyols  
CO<sub>2</sub> emissions reduction  
Pedigree analysis

### ABSTRACT

CO<sub>2</sub> utilisation is gaining interest as a potential element towards a sustainable economy. CO<sub>2</sub> can be used as feedstock in the synthesis of fuels, chemicals and polymers. This study presents a prospective assessment of carbon capture from a hydrogen unit at a refinery, where the CO<sub>2</sub> is either stored, or partly stored and partly utilised for polyols production. A methodology integrating technical, economic and environmental models with uncertainty analysis is used to assess the performance of carbon capture and storage or utilisation at the refinery.

Results show that only 10% of the CO<sub>2</sub> captured from an industrial hydrogen unit can be utilised in a commercial-scale polyol plant. This option has limited potential for large scale CO<sub>2</sub> mitigation from industrial sources. However, CO<sub>2</sub> capture from a hydrogen unit and its utilisation for the synthesis of polyols provides an interesting alternative from an economic perspective. The costs of CO<sub>2</sub>-based polyol are estimated at 1200 €/t polyol, 16% lower than those of conventional polyol. Furthermore, the costs of storing the remaining CO<sub>2</sub> are offset by the benefits of cheaper polyol production. Therefore, the combination of CO<sub>2</sub> capture and partial utilisation provides an improved business case over capture and storage alone. The environmental assessment shows that the climate change potential of this CO<sub>2</sub> utilisation system is 23% lower compared to a reference case in which no CO<sub>2</sub> is captured at the refinery. Five other environmental impact categories included in this study present slightly better performance for the utilisation case than for the reference case.

### 1. Introduction

Carbon dioxide can be used as feedstock in the synthesis of fuels, chemicals and materials [1,2]. CO<sub>2</sub> utilisation has recently gained interest and is, for instance, part of the latest European Union strategy to mitigate climate change [3]. Identifying and understanding the

challenges and performance of CO<sub>2</sub> utilisation technologies, however, is complex. There is no current consensus on what role these technologies can play in realising large reductions in CO<sub>2</sub> emissions [1]. To play a major role, the environmental performance of utilisation options should lead to extensive net CO<sub>2</sub> emission reductions. However, studies have shown that, depending on the process and system boundaries, net

**Abbreviations:** BEC, bare erected cost; CC, climate change; CCS, carbon capture and storage; CCU, carbon capture and utilisation; CCUS, carbon capture utilization and storage; CCS/U, carbon capture storage and utilisation; cPC, cyclic propylene carbonate; DMC, double metal cyanide; EDD, environmental due diligence; EDDiCCUT, Environmental Due Diligence of novel CO<sub>2</sub> Capture and Utilization Technologies; EPCC, engineering, procurement and construction costs; FD, fossil depletion; FE, freshwater eutrophication; FU, functional unit; G, glycerol; HP, high pressure; HT, human toxicity; LCA, life cycle assessment; LCI, life cycle inventory; LCOE, levelised cost of electricity; LCOP, levelised cost of product; LHV, lower heating value; LP, low pressure; MDEA, methyl diethanolamine; MPG, monopropylene glycol; NMVOC, non-methane volatile organic carbon; PBP, payback period; PMF, particulate matter formation; PEC, purchased equipment costs; PO, propylene oxide; POF, photochemical oxidant formation; PP, polyether polyol; PPC, polyethercarbonate polyol; PSA, pressure swing adsorption; PU, polyurethane; R & D, research & development; REF, reference case; SA, system area; TA, terrestrial acidification; WGS, water gas shift

\* Corresponding author.

E-mail addresses: [C.FernandezDacosta@uu.nl](mailto:C.FernandezDacosta@uu.nl) (C. Fernández-Dacosta), [M.W.vanderspek@uu.nl](mailto:M.W.vanderspek@uu.nl) (M. van der Spek), [christine.hung@ntnu.no](mailto:christine.hung@ntnu.no) (C.R. Hung), [gabriel.d.oregioni@ntnu.no](mailto:gabriel.d.oregioni@ntnu.no) (G.D. Oregioni), [ragnhild.skagestad@tel-tek.no](mailto:ragnhild.skagestad@tel-tek.no) (R. Skagestad), [pariharprashant@bharatpetroleum.in](mailto:pariharprashant@bharatpetroleum.in) (P. Parihar), [gokakdt@bharatpetroleum.in](mailto:gokakdt@bharatpetroleum.in) (D.T. Gokak), [anders.hammer.stromman@ntnu.no](mailto:anders.hammer.stromman@ntnu.no) (A.H. Strømman), [C.A.RamirezRamirez@tudelft.nl](mailto:C.A.RamirezRamirez@tudelft.nl) (A. Ramirez).

<http://dx.doi.org/10.1016/j.jcou.2017.08.005>

Received 28 November 2016; Received in revised form 8 June 2017; Accepted 5 August 2017

Available online 15 September 2017

2212-9820/ © 2017 Elsevier Ltd. All rights reserved.

emissions could in fact increase [2,4]. Besides reducing net CO<sub>2</sub> emissions, CO<sub>2</sub> utilisation needs to be a viable candidate for upscaling and offer sufficient revenue to become a realistic solution to climate change.

Although most literature sources link CO<sub>2</sub> utilisation to the power sector, CO<sub>2</sub> utilisation can and probably will be implemented in industrial clusters [5,6]. It is therefore important to assess how such concepts could also be integrated in industrial CO<sub>2</sub> mitigation strategies. The refinery sector is responsible for 10% of industrial emissions, of which 20% originates from the production of hydrogen [7]. Hydrogen production processes have the advantage that CO<sub>2</sub> separation facilities are already (partially) available on-site [8,9]. Furthermore, CO<sub>2</sub> capture can be implemented in hydrogen manufacturing units using commercially available technology in a cost-effective manner since the CO<sub>2</sub> stream is emitted at relatively high pressure. Moreover, waste heat integration from nearby facilities may reduce the energy (and cost) penalty of the capture unit [10].

One utilisation route that has drawn attention is the synthesis of polyethercarbonate polyol (PPC) for polyurethanes [11]. Different research groups have studied the feasibility of CO<sub>2</sub>-based polyol synthesis [12,13], and the manufacturing process has been described in several patents [14–17]. Moreover, Covestro (formerly BAYER Material Science) started a demonstration production line in 2016 in Dormagen, Germany, with a capacity of 5 kt/a of polyol for application in polyurethane (PU) flexible foams Bio-based News, 2016 indicating the technical feasibility of the option. Environmental assessments have shown that polyol synthesis based on a pilot plant for CO<sub>2</sub> capture from a power plant had lower global warming impacts than traditional polyol manufacturing routes [18]. However, the environmental assessment of this study was carried out at a demonstration scale rather than at commercial scale. Also, the mismatch between the CO<sub>2</sub> amounts emitted by the source and the amounts used by the CO<sub>2</sub> sink were not addressed. An integrated assessment of the technology, costs, and elaborate environmental impacts of CO<sub>2</sub> utilisation for polyol production at full commercial scale with system boundaries including an alternative CO<sub>2</sub> source and steam production, is yet to be carried out.

Polyols are already included in the chemicals product portfolio of some refinery companies. Therefore, the use of the large amounts of CO<sub>2</sub> emitted at a refinery for on-site polyol synthesis may benefit from synergies. With a current global polyols market of about 6.7 Mt/a, a demand of 0.12 Mt/a of CO<sub>2</sub> for polymer application is estimated if the European polyol market continues to grow at the expected rates [11]. However, this amount is small compared to the CO<sub>2</sub> emissions from industrial hydrogen units (220 Mt/a of CO<sub>2</sub>, [10]). To achieve a substantial CO<sub>2</sub> emission reduction, the same amounts of CO<sub>2</sub> waste captured at the refinery should be used as feedstock for polyol synthesis. As an alternative, the combination of partial CO<sub>2</sub> utilisation with partial CO<sub>2</sub> storage could be an interesting CO<sub>2</sub> mitigation option for industrial sources.

Due to their early stage of development [19], the knowledge base of most carbon capture and utilisation (CCU) technologies is characterized by large uncertainties and limited information due to confidentiality or the lack of process data. Therefore, a comprehensive uncertainty analysis that allows a better understanding of the knowledge gaps and robustness of the results must accompany an evaluation of the technology performance.

In this study, an integrated techno-economic and environmental assessment in combination with uncertainty analysis is conducted of CO<sub>2</sub> utilisation for polyol production at a refinery. The goal of this study is to investigate whether the implementation of CCU in combination with partial carbon storage is a cost-effective mitigation option for this industrial sector.

The structure of this paper is as follows: the integrated approach applied is presented in Section 2. The three different case studies developed are described in Section 2.1. The technical modelling is explained in Section 2.2. Based on the results of the technical models, an economic evaluation is carried out (Section 2.3). Technical and

economic models are used to develop a life cycle inventory and perform an environmental assessment (Section 2.4). Section 2.5 describes the uncertainty analysis. In Section 3, the outcomes and key indicators of the technical, economic, environmental and uncertainty assessments are presented and discussed. Finally, in Section 4, the limitations and the major implications of this research are addressed.

## 2. Methodology

This research uses the environmental due diligence (EDD) framework developed as part of the European EDDiCCUT project [20]. The framework provides a systematic assessment of existing and emerging carbon capture, storage and utilisation (CCS/U) technologies by integrating technical performance, cost estimation and life cycle inventory data with uncertainty analysis. The key elements of the framework and their application to the case study are described in this section.

### 2.1. Scoping

To assess whether the implementation of this CO<sub>2</sub> utilisation option in combination with partial carbon storage (CCUS) has advantages with respect to the common practice in industry, a reference case was designed: a refinery with a hydrogen unit without CO<sub>2</sub> capture and a conventional polyol synthesis process. Additionally, a case with carbon capture and storage (CCS) but without CO<sub>2</sub> utilisation was investigated to understand potential benefits of CCUS over CCS. To ensure system equivalence, in the reference and CCS cases, the same amount of hydrogen, polyol are produced as in the CCUS case.

The three different systems investigated are:

- i) Reference case (REF), Fig. 1a: refinery with H<sub>2</sub> manufacturing unit without CO<sub>2</sub> capture; conventional polyol synthesis.
- ii) Storage case (CCS), Fig. 1b: refinery with H<sub>2</sub> manufacturing unit with CO<sub>2</sub> capture and storage; conventional polyol synthesis.
- iii) Utilisation and partial storage case (CCUS), Fig. 1c: refinery with H<sub>2</sub> manufacturing unit with CO<sub>2</sub> capture and utilisation for CO<sub>2</sub>-based polyol synthesis. The captured CO<sub>2</sub> that cannot be used in polyol synthesis is stored, similar to case ii.

The temporal scope for all cases is 2015 and the geographical location is Northwestern Europe. The same process sizes were defined for the three cases: 77 kt/a of H<sub>2</sub> production and 250 kt/a of polyol production (based on a world-class scale plant). The different processes that are part of the value chains have been combined in interconnected system areas (SA) taking into account sequence, location and similarities. In this way, data is consistently organized and easily shared among the different research disciplines (technical, economic and environmental). Fig. 1 presents the SAs of each case study. A more detailed description of each process is provided in the Supplementary material.

#### 2.1.1. H<sub>2</sub> production

The reference case (Fig. 2a) is based on data from a real refinery in Asia, which produces 77 kt/a of H<sub>2</sub> at 99.99% purity via naphtha steam reforming followed by a water gas shift reaction (WGS) and pressure swing adsorption (PSA). In this refinery, desulphurised naphtha and steam are pre-heated to 520 °C and fed to the reformer (860 °C, 25 bar). After heat recovery, the reformer products flow to the WGS reactor (400 °C, 25 bar). The WGS product stream contains 43 wt% water, which is removed in a process condensate separator unit. After water removal, H<sub>2</sub> is recovered in a pressure swing adsorption unit (PSA, 40 °C, 25 bar) with an overall yield of 89 wt%. The offgas of the PSA unit is fed to the furnace section of the reformer and burned with air for heat recovery. The energy provided by burning the PSA offgas is not enough to drive the endothermic steam reforming reactions, so

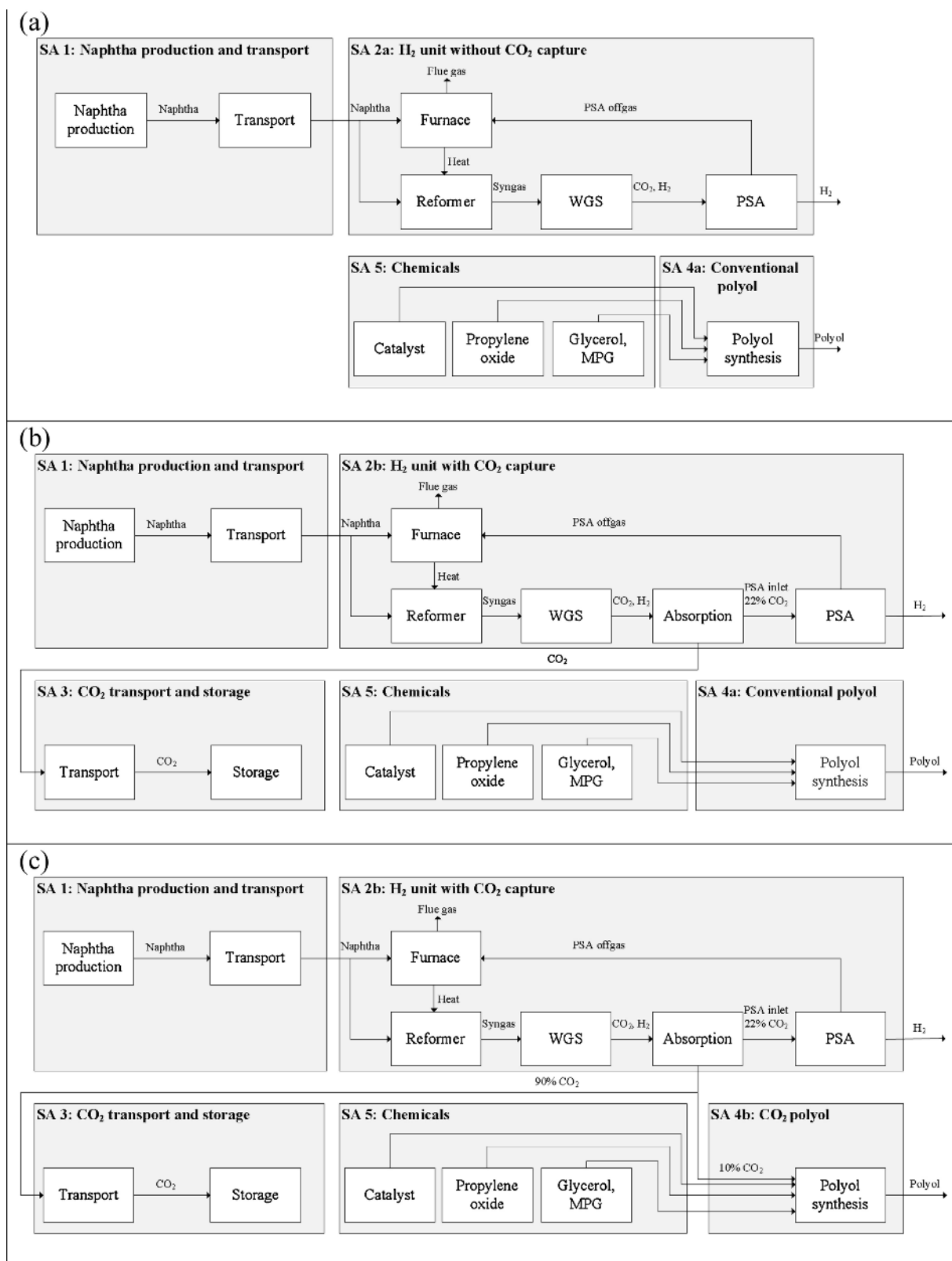

Fig. 1. System areas (SA) of the different case studies. (a) Reference case (REF), (b) storage case (CCS), (c) utilisation case (CCU). MPG: monopropylene glycol; PSA: pressure swing adsorption; WGS: water gas shift.

additional naphtha is used as fuel to achieve the reformer temperature and duty requirements. Hot flue gases and process gas from the reformer are cooled by preheating the reformer feed and by generating steam. In the reference case, there is no carbon capture, thus 890 kt/a of

CO<sub>2</sub> are emitted to the atmosphere.

Alternatively, CO<sub>2</sub> can be captured in the H<sub>2</sub> unit (Fig. 2c). As in the previous case, H<sub>2</sub> is produced via naphtha steam reforming followed by a WGS reaction. The most efficient CO<sub>2</sub> capture point in steam

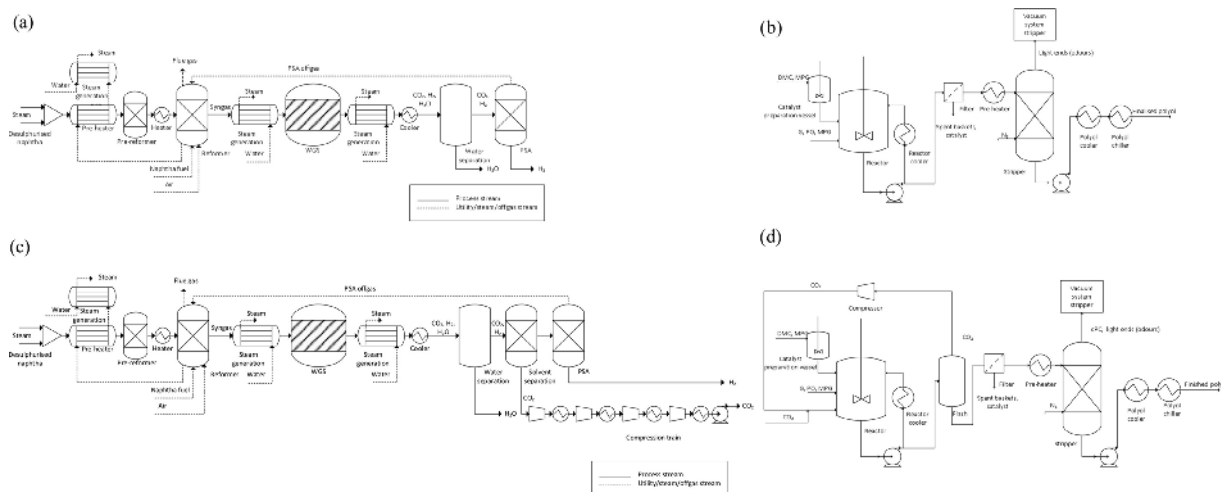

Fig. 2. Process flow diagrams. (a) H<sub>2</sub> unit without CO<sub>2</sub> capture; (b) Conventional polyol synthesis; (c) H<sub>2</sub> unit with CO<sub>2</sub> capture; (d) CO<sub>2</sub>-based polyol synthesis. cPC: cyclic propylene carbonate; DMC: double metal cyanide; MPG: monopropylene glycol; PO: propylene oxide; PSA: pressure swing adsorption; WGS: water gas shift.

reforming facilities is upstream the PSA unit [10]. Chemical absorption with ADIP-X solvent (a mixture of methyl diethanolamine (MDEA) and piperazine) leads to a capture efficiency of 95% of the total CO<sub>2</sub> emissions, which corresponds to 552 kt/a of CO<sub>2</sub>. Also in this case, the offgas of the PSA unit is burned in the furnace of the reformer. Since the CO<sub>2</sub> is captured upstream the PSA, the PSA offgas has higher calorific value, and consequently naphtha fuel requirements for the furnace are lowered with respect to the reference case. The reduced CO<sub>2</sub> content in the feed gas will affect the PSA cycles and time, which should be adjusted so the separation targets are met despite the CO<sub>2</sub> feed variation. Note that the impact of CO<sub>2</sub> capture on the performance of the PSA unit is however not covered in the scope of this study. H<sub>2</sub> recovery efficiency in the PSA was assumed 89% for all cases.

The captured CO<sub>2</sub> can be either transported for storage (CCS case) or be partially utilised in polyol synthesis and partially stored (CCUS case). In the CCS case, a compression train formed by four compression stages with intercoolers and a final pump is applied to reach 110 bar. At that pressure, CO<sub>2</sub> is in a supercritical state for transport 2.5 km onshore and 95 km to an offshore aquifer, where it is stored. In the CCUS case, the CO<sub>2</sub> stream is split after the second compression stage (20 bar). The required amount of CO<sub>2</sub> is used in polyol synthesis while the rest is further compressed to 110 bar and sent to storage. In the CCS and CCUS cases, CO<sub>2</sub> emissions are reduced to 271 kt/a. Further details are provided in the Supplementary material.

### 2.1.2. Polyol synthesis

Propylene oxide (PO), glycerol (G) and monopropylene glycol (MPG) are the starting materials in the synthesis route of conventional polyether polyol (PP), (Fig. 2b). The reaction takes place at 135 °C and 3 bar [21]. Double metal cyanide (DMC) is used as catalyst, recovered via filtration after the reaction step and disposed as waste. Odours and other impurities are removed from the polyol product in a vacuum-stripping step (140 °C, 25 mbar, [15,21]).

The manufacture of CO<sub>2</sub>-based polyol follows similar steps as the conventional route (Fig. 2d). The key difference is that part of the PO used in the conventional route is substituted by CO<sub>2</sub>. Reaction conditions are 135 °C and 20 bar [21]. After the reaction, the excess CO<sub>2</sub> is recovered in a flash step and recycled back to the reaction. Cyclic propylene carbonate (cPC) is produced as a by-product [13,18]. In this study, we assume it is removed in the vacuum stripper together with the odours [15]. The CO<sub>2</sub> content in the polyol is 20 wt% [22,18] because at higher shares, the polyol viscosity increases to the point of making it unsuitable for flexible PU foam application [13,23]. In the Supplementary material, a more detailed description

of each process is provided.

### 2.2. Technical - process modelling

Process models were developed for the H<sub>2</sub> unit with and without CO<sub>2</sub> capture and for the conventional and CO<sub>2</sub>-based polyol synthesis (SA 2a, 2b, 4a and 4b in Fig. 1).

The H<sub>2</sub> unit was modelled in Aspen Plus V8.4. Using process data from a refinery hydrogen manufacturing unit in Asia, the model of the H<sub>2</sub> unit was validated with good accuracy ( $\pm 1\%$  deviation with refinery process data, Appendix A). The process streams, pieces of equipment and the efficiencies of the reformer, WGS and PSA unit are equal regardless the location of the H<sub>2</sub> unit. However, cooling water temperature, cooling requirements and availability vary depending on the local ambient temperature. Since the geographical scope of this study is Northwestern Europe, sea filtered water at 15 °C with no limited availability is used to fulfill the cooling requirements.

The model of the capture unit was based on a previous in-house study at Utrecht University [10]. The H<sub>2</sub> concentration entering the PSA must be equal to or greater than 70 mol% for an economical PSA process that achieves 85% per-pass H<sub>2</sub> separation [24]. The H<sub>2</sub> concentration entering the PSA was 72 mol% in the model of the H<sub>2</sub> unit without capture and 91 mol% in the model of the H<sub>2</sub> unit with capture.

The conventional polyol production process was assessed with a spreadsheet model using reaction parameters, polyol properties and process line-ups described by experts in polyol R&D and manufacturing [21]. The CO<sub>2</sub>-based polyol model was based on several literature sources [12,13,18] and patents [14–17] and also specified in a spreadsheet. Following consultation with experts from the polyol manufacturing sector [21], the heat of reaction of the CO<sub>2</sub>-based polyol is reduced compared to the heat of reaction of the conventional polyol, by the amount of CO<sub>2</sub> introduced into the polyol. The PO ring opening reaction is exothermic [25] and the CO<sub>2</sub> bond breaking is an endothermic reaction [26]. Since in the CO<sub>2</sub>-based polyol synthesis, CO<sub>2</sub> substitutes part of the PO that reacts, the total heat released in the CO<sub>2</sub>-based polyol is lower than that of conventional polyol. The overall polymerization reaction in both conventional and CO<sub>2</sub>-based polyol synthesis is exothermic, but the energy released in the CO<sub>2</sub>-based polyol is lower. Although an external cooler is required in both exothermic reaction steps, the cooling requirement of the CO<sub>2</sub>-based polyol synthesis is lower than that of the conventional polyol. Details on the data used in the polyols models are reported in Appendix A and the Supplementary material. Using these models, the mass and heat balances and the equipment sizes of the three cases (REF, CCS, CCUS) were

**Table 1**

Key performance indicators. LCOP: levelised cost of product; PBP: payback period; NMVOC: non-methane volatile organic carbon.

Technical	Units
CO <sub>2</sub> emissions	kt/a
CO <sub>2</sub> utilised	kt/a
CO <sub>2</sub> stored	kt/a
Naphtha fuel consumption	kt/a
PO consumption	kt/a
Primary energy use	GWh
Economic	Units
Capex	MC
Opex	MC/a
LCOP <sub>25</sub> - H <sub>2</sub>	€/GJ H <sub>2</sub>
LCOP <sub>25</sub> - PPC	€/kg polyol
Break-even CO <sub>2</sub> price	€/t CO <sub>2</sub>
PBP	years
Environmental	Units
Climate change	kg CO <sub>2</sub> eq
Photochemical oxidant formation	kg NMVOC
Fossil depletion	kg oil eq

calculated. Key performance indicators were selected to compare the technical performance of the three alternatives (Table 1).

CO<sub>2</sub> flows were chosen to evaluate the emissions reduction and potential for utilization. Naphtha fuel consumption was selected to quantify the savings in the cases with CO<sub>2</sub> capture, due to an enhanced heating value of the PSA offgas burned in the furnace of the reformer. PO is the main feedstock for polyol synthesis, and replaced by CO<sub>2</sub> in the utilization case. The primary energy use indicator reflects the increase in energy demand due to the capture unit and compression train in the capture cases and the additional energy of the CO<sub>2</sub>-based polyol production.

### 2.3. Economic – cost estimation

To carry out the cost estimation, it was assumed that the H<sub>2</sub> unit and the polyol plant are extensions to an existing plant located in Northwestern Europe. They are built in an existing industrial area with all utilities and support in place. Specific control rooms or buildings were excluded. The host site was assumed to deliver the utilities and therefore facilities such as cooling towers or steam production were excluded from the cost estimates. The same level of detail was implemented for each case study (REF, CCS, CCUS), allowing a fair comparison of the results.

To estimate the capital costs, a detailed equipment list was derived from the technical models. The Capex of SA 2 (H<sub>2</sub> unit) was based on a previous detailed in-house economic evaluation of a H<sub>2</sub> unit with the same pieces of equipment and stream compositions, but with smaller capacity [10]. The different sizes of the equipment were adjusted to the equipment sizes required in this study using the exponent method [27]. The scale exponent varies for different types of plants. As a typical value for petrochemical processes, 0.65 was chosen [27].

For estimating capital costs of SA 4 (polyol synthesis), design conditions and equipment size from the technical models were used as input to the Aspen Capital Cost Estimator. Aspen software provided the purchased equipment costs (PEC). Based on the PEC, the bare erected costs of the equipment (BEC) and the engineering, procurement and construction costs (EPCC) were estimated applying typical factors for project capital cost items (Supplementary material, [28]). To calculate the total plant costs, a 20% project contingency was assumed.

The Opex estimates for all SAs were based on the mass and energy flows from the technical models and current or historical market prices of utilities and chemicals. Labour costs were estimated based on the amount of operators and engineers per SA and their assumed wages

(based on [29,30]). Maintenance costs were assumed 4% of the capital costs [27]. Appendix B provides further details on the values assumed for the Opex estimation.

Data from the European Zero Emission Platform [31] was used as basis for estimating CO<sub>2</sub> transport and storage costs (SA 3). It was assumed that the number of injection wells drilled is proportional to the amount of CO<sub>2</sub> stored and that the field has constant injectivity and permeability. Therefore, the storage costs provided in the ZEP report were proportionally adjusted to the amount of CO<sub>2</sub> stored in each case study. Transport costs were estimated based on the pipeline diameter, length and pressure drop using an in-house pipeline model.

Economic analyses of CO<sub>2</sub> capture systems typically use the levelised cost of electricity (LCOE) as economic performance indicator [32]. In this study, we used an analogous indicator called the levelised cost of product (LCOP), (Table 1). LCOP is a measure of the H<sub>2</sub> and polyol prices that the production plants need to receive in order to achieve a required return on investment. It incorporates all cash flows into and out of the project, levelised over the project lifetime, and normalized over the levelised amount of H<sub>2</sub> and/or polyol that is generated in that period. The LCOP was calculated for the two products of the system, H<sub>2</sub> and polyol, following Eq. (1):

$$LCOP = \frac{\sum_{i=1}^n \frac{I_i + O_i}{(1+r)^i}}{\sum_{i=1}^n \frac{P_i}{(1+r)^i}} \quad (1)$$

Where:

LCOP: Levelised cost of product, (€/GJ H<sub>2</sub>, €/kg polyol)

I<sub>i</sub>: Investment cost in year i, (€/a)

O<sub>i</sub>: Operational costs in year i, (€/a)

r: Real discount rate, (%)

P<sub>i</sub>: Product production in year i, (GJ H<sub>2</sub>, kg polyol)

This indicator allows the comparison of the economic performance of H<sub>2</sub> and polyol synthesis following different routes, as in the three cases investigated (REF, CCS and CCUS). In the CCUS case, the LCOP per kg of polyol included the costs of polyol production and a share of the costs of CO<sub>2</sub> capture and compression. This fraction was estimated using the mass percentage of the captured CO<sub>2</sub> that was used for polyol production. The LCOP per MJ of H<sub>2</sub> included the costs of SA 1, SA 2, SA 3 and the remaining capture and compression costs.

A break-even analysis was carried out based on the LCOP of H<sub>2</sub> and polyol, their annual production capacities and the amount of CO<sub>2</sub> emitted in each case study. The break-even analysis shows the minimum cost of CO<sub>2</sub> (€/t) that would make the CCS and CCUS cases, including CO<sub>2</sub> capture, transport and storage, economically more attractive than the reference case.

The payback period (PBP) was also estimated to compare the time needed to recover the investment in each case study. A H<sub>2</sub> market price of 1135 €/t was assumed based on crude prices of about 45 US\$/barrel (refinery data), since naphtha derived from crude is the source of H<sub>2</sub>. The market price of the polyol was estimated based on the values reported in Shen et al. [33], which are specific for flexible polyols for polyurethane foam application. The value was updated to 2015 using the chemical products price index [34] so a value of 1700 €/t of polyol was used for the payback period calculation.

### 2.4. Environmental - life cycle assessment

In this framework, a hybrid life cycle assessment (LCA) was used. Hybrid life cycle approaches combine economic and process (technical) data to develop life cycle inventories (LCI) with high detail from process flows and improved completeness by addition of cost data. This allows for input of plant-specific production and capital expenses data that can improve LCA modelling as conventional LCA comprises a high resolution of bottom-up physical processes but suffers from incomplete system boundaries [35].

The environmental assessment comprises the inventory development and impact quantification for the whole value chain. A hybrid approach was applied to assess the environmental performance of the H<sub>2</sub> production, CO<sub>2</sub> capture, CO<sub>2</sub> compression and both conventional and CO<sub>2</sub>-based polyol units. For these units, process data from the technical assessment was supplemented with the capital cost data to model the infrastructure (Supplementary material). The value chains (including infrastructure) for naphtha and precursor chemicals and CO<sub>2</sub> transport and storage, were modelled entirely using a process LCA approach. Key assumptions taken and the full LCI are in the Supplementary material. Advanced contribution analysis and structural path analysis [36] were used to determine key processes and process chains responsible for environmental impacts.

Seven environmental impact indicators were evaluated applying the ReCiPe 1.11 characterization methodology with the hierarchist approach (2012) [37]. The complete list of the environmental indicators evaluated is presented in Appendix C. The *ecoinvent* v.3.2 database (2015) [38] was used to characterise the physical background of the production systems. The 2011 dataset from the EXIOBASE 3.3 environmentally extended, multi-regional supply-use/input-output database [39] was used to model the economic background for infrastructure of some SAs for hybrid modelling. Since a key driver of applying CCU is to reduce CO<sub>2</sub> emissions and to substitute fossil feedstock by CO<sub>2</sub>, from the seven indicators included in the environmental assessment, climate change (CC) and fossil depletion (FD) were selected as key environmental performance indicators to compare the CCUS system with the reference and CCS system (Table 1). Photochemical oxidant formation (POF) was also selected as a key indicator to capture the differences in impact from the H<sub>2</sub> unit with and without carbon capture due to a different composition of the PSA offgas.

As the goal of the study is to assess the co-production of hydrogen and polyols, the system expansion approach is used for fair comparison of the three systems. The functional unit for all three cases is thus the production of 1 MJ H<sub>2</sub> (LHV base), 0.03 kg polyols and 0.187 kg low pressure steam. In the REF and CCS cases, the polyols are produced through conventional synthesis, while in the CCUS case some of the captured CO<sub>2</sub> is used as a feedstock to the novel polyol synthesis. Annual product output, or plant capacity, remained constant for all three cases, at 77 kt/a H<sub>2</sub> production and 250 kt/a polyol production. To allow a fair comparison, the same net output of 1727 kt/a of low pressure steam from heat integration is assumed in the three case studies. As a result, additional low pressure steam, which is produced in a natural gas boiler, is required to meet this output in the CCS and CCUS cases.

### 2.5. Uncertainty analysis

Qualitative and quantitative uncertainties were identified performing pedigree analysis and sensitivity analysis, respectively. Pedigree analysis addresses the strengths and weaknesses in the knowledge base underlying a parameter and/or model by carefully reviewing the background of that parameter/model [40,41]. In combination with sensitivity analysis, pedigree analysis allows understanding the limitations of the prospective assessment carried out for the CCS and CCUS technologies studied in this work. Uncertainties, strengths and weaknesses of particular areas are identified at an early stage, which is added value information for researchers, companies and policy makers when assessing the performance of emerging CCS/U technologies.

To minimize subjectivity, pre-defined pedigree matrices were used (Appendix D). For each research discipline (technical, economic, environmental), a different pedigree matrix was applied, reflecting the specific characteristics of technical, economic, or environmental data and models. An ordinal scale from 0 (weak) to 4 (strong) was used to evaluate the knowledge strength of each parameter or model. The scores were expressed with a colour code to aid the easy interpretation

**Table 2**

Sensitivity analysis to technical and economic input parameters. Base value and % of change.

Input parameter	Units	Base value	% Change
<b>Technical</b>			
Polyol selectivity	%	94	± 5%
Heat of reaction	kJ/kg polyol	16.34	± 25%
Reaction P	bar	20	± 20%
Reaction T	°C	135	± 26%
CO <sub>2</sub> excess	%	40	± 25%
Chilled water T	°C	10	± 50%
<b>Economic</b>			
Naphtha price	€/tonne	480	± 20%
PO price	€/tonne	1400	± 20%
Glycerol price	€/tonne	730	± 20%
Capex H <sub>2</sub> unit	M€	156	−30%/ +50%
Capex polyol	M€	21	−30%/ +50%
Real discount rate	%	7.5	± 30%

of the uncertainty status (red for low knowledge base/high uncertainty, green for high knowledge base/low uncertainty).

Sensitivity analysis was conducted for the technical and economic models of the CCUS case. A contribution analysis of the SAs to the environmental impacts was carried out for the environmental assessment. Six technical input parameters were varied to assess their impact on the primary energy requirements of the total production system (H<sub>2</sub> unit with capture (SA 2b) and the CO<sub>2</sub>-polyol synthesis (SA 4b), (Table 2). All these parameters (with exception of the chilled water temperature) are reaction parameters of the CO<sub>2</sub>-polyol synthesis. They were selected because the CO<sub>2</sub>-polyol is the most novel part of the system and therefore the level of uncertainty of those input parameters is intrinsically higher (results shown in Section 3.1.1, Table 5). The economic parameters chosen for the sensitivity analysis were the prices of the major feedstocks (naphtha, PO and glycerol), the Capex of the H<sub>2</sub> unit and polyol SA and the discount rate. The Capex was varied −30% to +50% because this is the inaccuracy range of the estimated baseline values [42]. The effect of varying these parameters on the LCOP of H<sub>2</sub> and polyol was calculated to identify in which scenarios CCUS for polyols is still an interesting business case.

## 3. Results and discussion

The results of the technical, economic and environmental models developed for the reference, CCS and CCUS cases are discussed in the next sections. The technical model outputs are presented first because the cost estimation built upon them. Since both the technical and economic results were used for the life cycle assessment, the environmental results are presented last. Uncertainty analysis outcomes are discussed within each research area (technical, cost and environmental).

**Table 3**

Technical performance indicators of the REF, CCS, and CCUS systems.

Performance indicator	Units	REF	CCS	CCUS
<b>CO<sub>2</sub> flows</b>				
CO <sub>2</sub> emissions	kt/a	890	271	271
CO <sub>2</sub> stored	kt/a	–	552	495
CO <sub>2</sub> utilised	kt/a	–	–	58
<b>Major feedstock and energy flows</b>				
Naphtha fuel consumption	kt/a	70	60	60
PO consumption	kt/a	243	243	202
Primary energy use	GWh	125	613	623

### 3.1. Technical assessment

Table 3 shows the key results of the technical models. Further details of the energy and mass balances are shown in Appendix A.

The combination of H<sub>2</sub> and polyol production processes is interesting from both the refinery and polyol manufacturing perspectives. CO<sub>2</sub> capture in the refinery leads to lower emissions. In the CCS and CCUS cases, there is a reduction of 65% of the CO<sub>2</sub> emissions with respect to the reference case. The remaining 35% of CO<sub>2</sub> is emitted to the atmosphere as part of the reformer furnace flue gas. More specifically, since the commercial-scale polyol plant (250 kt/a of polyol production) can only use 10% of the CO<sub>2</sub> captured from the typically sized hydrogen plant (77 kt/a of H<sub>2</sub> produced), the rest of the captured CO<sub>2</sub> is sent to storage in the CCUS case. This is a relevant finding because it shows the limitations of this CO<sub>2</sub> utilisation option in mitigating the CO<sub>2</sub> emissions of an industrial source. Alternatively, the implementation of CO<sub>2</sub> utilisation to larger markets such as transport fuels have been investigated [43]. The production of fuels from CO<sub>2</sub> would not contribute to mitigation of CO<sub>2</sub> emissions by long-term storage time before the CO<sub>2</sub> is re-emitted to the atmosphere as in the polyol case, but by integrating renewable energy into the fuel-value chain [44].

From a refinery perspective, 14 wt% less naphtha is needed as fuel for the reformer furnace in the CCS and CCUS cases. Since CO<sub>2</sub> is captured upstream the PSA, the PSA offgas has an enhanced heating value and contributes more heat to the reformer furnace. The use of CO<sub>2</sub> as feedstock for the polyol synthesis reduces the requirements on fossil resource demand. CO<sub>2</sub>-based polyol benefits from 17 wt% lower PO feedstock requirement. Although the reduction of the amounts of naphtha and PO feedstock seems small, it has a substantial positive impact on the economic and environmental performances of the CCUS case (next sections). So although the CO<sub>2</sub> utilisation capability of CO<sub>2</sub>-based polyols is small, there is added value in a significant replacement of fossil feedstock.

Note also that the introduction of a capture unit and a compression train requires extra utilities (Table 4). In all case studies, there is low-pressure (LP) steam produced from heat integration (indicated by the minus sign). However, in the CCS and CCUS cases, part of the produced steam is required in the CO<sub>2</sub> capture unit; the net steam production is reduced by 35% as compared to the reference case. Cooling water and electricity requirements are larger in the CCS and CCUS cases as compared with the reference case (115% and 290%, respectively) because of the capture unit and compression train. Therefore, the primary energy use increases in the CCS and CCUS cases with respect to the reference case (Table 3). The CCUS case shows slightly more primary energy used with respect to the CCS case due to more steam and electricity needed in the pre-heater of the stripper and in the compressor for recycle CO<sub>2</sub>.

#### 3.1.1. Uncertainty analysis

The knowledge base uncertainty of the different research areas was systematically assessed using pre-defined pedigree matrices (Appendix D). Scores for the pedigree criteria of the technical input data and submodels are presented in Tables 5 and 6.

The input parameters have a high score for the Proxy criterion since they were based on data from the refinery and information from industrial experts in carbon capture and polyol synthesis. The Theoretical

**Table 4**  
Utility flows into the REF, CCS, and CCUS systems.

Model output	Units	REF	CCS	CCUS
LP steam	kt/a	−1 727	−1 126	−1 117
Cooling water	kt/a	11 251	24 422	24 364
Electricity	kW	1 920	7 424	7 576

understanding is also of good quality. The Empirical basis and the Methodological rigour show a higher level of uncertainty. The input data of the conventional polyol process were provided by experts of a polyol R & D and manufacturing plant [21]. However, the input data of the CO<sub>2</sub>-based polyol was derived from conventional polyol data and thereby the level of uncertainty increased. The Validation process is the criterion with the lowest scores, especially for the polyol SAs. The values of the conventional polyol were validated against data from experts of a polyol manufacturing site. However, this was not done for the CO<sub>2</sub>-based polyols. Although there is experimental work and a demonstration plant has been built for CO<sub>2</sub>-based polyols, publicly available peer-reviewed or independent industrial independent information that could be used for validation purposes was unavailable.

The pedigree assessment of the technical submodels shows good Theoretical understanding and Methodological rigour. The CO<sub>2</sub>-based polyol system area presents higher uncertainty in the Methodological rigour since the model was derived from the conventional polyol system. The Modelling resources scored 2 for all SAs except for the conventional polyol synthesis, which scored 3. Most of the technical models were developed by a single modeller with limited expertise in this area but with enough time to build skills for the specific purpose. However, for the conventional polyol, senior and junior polyol technologists contributed to the development of the model, and therefore the Modelling resources present higher scores. As for the input data, the Validation process shows the highest uncertainties. The models of the H<sub>2</sub> unit were validated by comparing them with data from a real refinery (Appendix A), and therefore they have the highest score. Although there is no information on a real refinery with the specific CO<sub>2</sub> capture unit included in the models, CO<sub>2</sub> capture by chemical absorption has been applied to other systems. The model of the capture unit could thus be validated although the measurements included proxy variables or spanned a limited domain. In the case of the polyol processes, the flowsheets were validated by personal communication with experts from a polyol manufacturing site [21]. This information was not peer-reviewed, and therefore lower pedigree scores were given to these SAs. There was no validation performed for the thermodynamics, chemistry, and kinetics included in the models, resulting in the low scores.

Besides the qualitative pedigree analysis, a sensitivity analysis was carried out to quantify the effect that six selected input parameters have on the primary energy requirements for the polyol system area (SA 4b), and for the overall system (SA 2b and SA 4b).

Fig. 3 shows that the reaction temperature is the parameter with the largest influence on the primary energy requirement of the polyol system area ( $\pm 10\%$ ). The temperature of the reaction products flowing into the pre-heater of the stripper varies and therefore affects the amount of steam consumed in the pre-heater. However, variations in the reaction pressure have the most important effect on the overall system (Fig. 3b). This is because the reaction temperature only affects the polyol system area, while the reaction pressure also affects the CO<sub>2</sub> compression train. Therefore, changes in the reaction pressure have larger implications in the primary energy requirements of the overall system. Nevertheless, the primary energy use of the overall system only shows minor changes ( $\pm 2\%$ ) because only 10% of the total amount of CO<sub>2</sub> captured is used in the polyol synthesis. This shows that changes to input parameters in the polyol SA only have a minor impact on the energy use of the overall system. It also means that the higher uncertainty in the knowledge base of the polyol model has little impact on the performance of the total system. The higher uncertainty of the polyol SA is therefore justified for the purpose of assessing the technical performance on the integrated system.

### 3.2. Economic assessment

Table 7 displays the economic performance indicators of the reference, CCS and CCUS cases. The Capex is 60% lower in the reference case because it does not include a capture unit nor a compression train.



**Table 5**  
Pedigree scores for technical input data.

	Proxy	Empirical basis	Theoretical understanding	Methodological rigour	Validation process
<b>SA 2a: H<sub>2</sub> unit without CO<sub>2</sub> capture</b>					
Feed streams	4	3	4	3	-
Design parameters	3	3	4	4	3
Boundary conditions	4	2	4	3	3
Other physical properties	4	4	4	4	3
<b>SA 2b: CO<sub>2</sub> capture unit</b>					
Feed streams	4	3	4	3	3
Design parameters	3	2	3	3	2
Boundary conditions	4	2	4	3	3
Other physical properties	4	4	4	4	3
<b>SA 4a: Conventional polyol</b>					
Feed streams	4	3	4	3	-
Design parameters	3	3	3	2	1
Boundary conditions	4	2	4	3	3
Other physical properties	4	3	4	3	1
<b>SA 4b: CO<sub>2</sub>-based polyol</b>					
Feed streams	4	3	4	2	-
Design parameters	3	2	3	2	1
Boundary conditions	4	2	4	3	3
Other physical properties	4	2	4	2	0

**Table 6**  
Pedigree scores for technical submodels.

	Theoretical understanding	Methodological rigour	Modelling resources	Validation process
<b>SA 2a: H<sub>2</sub> unit without CO<sub>2</sub> capture</b>				
Flowsheet	4	3	2	4
Thermodynamics	4	4	2	3
Chemistry & Kinetics	4	3	2	3
<b>SA 2b: CO<sub>2</sub> capture unit</b>				
Flowsheet	4	3	2	2
Thermodynamics	3	3	2	2
Chemistry & Kinetics	3	3	2	2
<b>SA 4a: Conventional polyol</b>				
Flowsheet	4	3	3	1
Thermodynamics	3	3	3	1
Chemistry & Kinetics	3	3	3	0
<b>SA 4b: CO<sub>2</sub>-based polyol</b>				
Flowsheet	3	2	2	1
Thermodynamics	3	2	2	0
Chemistry & Kinetics	3	2	2	0

The cost of PO (included in the Opex) is the main driver of the differences among the total cost in the three cases. In the CCUS case, the CO<sub>2</sub> captured from the refinery replaces 17 wt% of the PO used as feedstock for polyol synthesis. Thus, whilst the LCOP per GJ of H<sub>2</sub> is higher in the CCS and CCUS cases (+58/+55% compared to the reference), the LCOP per kg polyol produced is the lowest in the utilisation case

**Table 7**  
Economic performance indicators of the REF, CCS, and CCUS systems.

Performance indicator	Units	REF	CCS	CCU
Capex	M€	155	391	383
Opex	M€/a	384	390	332
LCOP <sub>25</sub> - H <sub>2</sub>	€/GJ H <sub>2</sub>	5.0	7.8	7.7
LCOP <sub>25</sub> - PPC	€/kg polyol	1.4	1.4	1.2
Break-even CO <sub>2</sub> cost	€/t CO <sub>2</sub>	-	47	-47
PBP	years	5	8	6

\*break-even CO<sub>2</sub> cost estimated with LCOP.  
PBP estimated with market prices (1135 €/t H<sub>2</sub>; 1700 €/t polyol).

(-16% with respect to the reference and CCS cases).

The break-even analysis shows that 47 €/t (Table 7) is the minimum CO<sub>2</sub> cost that would make the CCS case economically more attractive than the reference case. However, a negative CO<sub>2</sub> cost (coincidentally, also -47 €/t) would be required to make the reference case more cost-effective than the CCUS case. This shows that at system level (both H<sub>2</sub> unit and polyol plant), CCUS is the most economically interesting alternative. The reduction in the polyol costs in the CCUS case compensates for the higher LCOP of H<sub>2</sub>. Implementation of carbon capture at refineries sets a business case when CO<sub>2</sub> is partially utilised as in the CCUS case, but not when there is only CO<sub>2</sub> storage, as in the CCS case.

Assuming a H<sub>2</sub> market price of 1135 €/t and a polyol market price of 1700 €/tonne, the payback period (PBP) is 5 years in the reference case, 8 years in the CCS case and 6 years in the CCUS case. The high PBP of the CCS case can be explained by the additional capital investment required for the capture and compression unit and the lack of economic

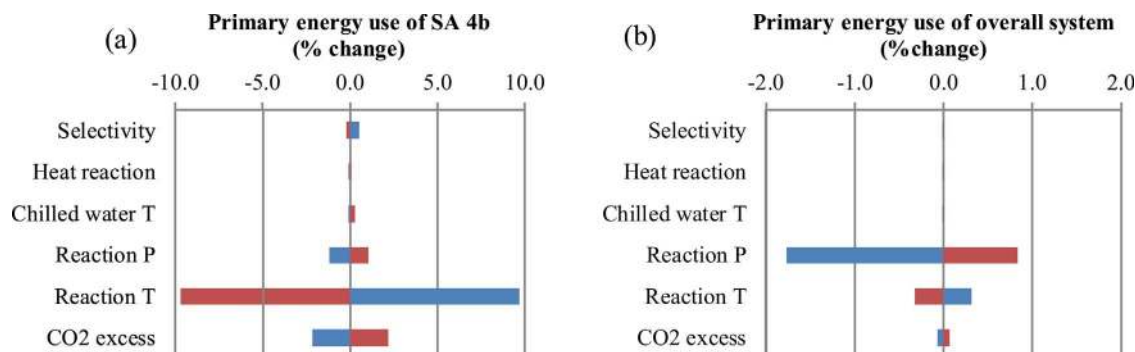

**Fig. 3.** Tornado diagram: sensitivity of primary energy use to selected input parameters. (a) Polyol synthesis. (b) Overall system: H<sub>2</sub> unit with capture and CO<sub>2</sub>-polyol synthesis.

**Table 8**

Capex contribution per system area (M€). The dashes (–) are due to only operational cost for that system area.

System area	REF (M€)	CCS (M€)	CCUS (M€)
1	Naphtha production & transport	–	–
2a	H <sub>2</sub> unit without CO <sub>2</sub> capture	135	–
2b	H <sub>2</sub> unit with CO <sub>2</sub> capture	–	156
3	CO <sub>2</sub> transport and storage	–	215
4a	Conventional polyol synthesis	20	20
4b	CO <sub>2</sub> -based polyol synthesis	–	21
5	Chemicals	–	–
Total H <sub>2</sub> unit + storage	135	370	361
Total polyol	20	20	22
TOTAL	155	391	383

**Table 9**

Opex contribution per system area (M€/a).

System area	REF (M€/a)	CCS (M€/a)	CCUS (M€/a)
1	Naphtha production & transport	33.7	28.7
2a	H <sub>2</sub> unit without CO <sub>2</sub> capture	2.6	–
2b	H <sub>2</sub> unit with CO <sub>2</sub> capture	–	10.1
3	CO <sub>2</sub> transport and storage	–	2.8
4a	Conventional polyol synthesis	1.1	1.1
4b	CO <sub>2</sub> -based polyol synthesis	–	1.3
5	Chemicals	346.9	346.9
Total H <sub>2</sub> unit	36.3	41.7	40.4
Total polyol	348.0	348.0	291.6
TOTAL	384.4	389.7	332.0

benefits from CO<sub>2</sub> utilisation due to lower PO feedstock demand, both of which are present in the CCUS case.

In **Tables 8 and 9**, the Capex and Opex are presented per system area. The Capex of the H<sub>2</sub> unit is larger when it includes a CO<sub>2</sub> capture unit and compression (SA 2b in CCS and CCUS cases). There is a small difference in the Capex of CO<sub>2</sub> transport and storage (SA 3) between the CCS and the CCUS cases. In the CCUS case, 10% of the captured CO<sub>2</sub> is used in polyol synthesis, and therefore the CO<sub>2</sub> transported and stored is 90% of the CO<sub>2</sub> transported and stored in the CCS case. The CO<sub>2</sub> flow determines the costs of storage and the pipeline diameter. However, its length and materials are the main drivers of the Capex. Since the pipeline diameter is very similar and the length is the same in both cases, the Capex for transport is only slightly lower in the CCUS case. Details on transport and storage costs are available in the Supplementary material.

The CO<sub>2</sub>-based polyol route (SA 4b) has only slightly (3%) higher Capex than the conventional route (SA 4a). The difference is caused by an additional flash vessel and a compressor, which are required to separate and recycle the excess of CO<sub>2</sub> after the reaction. Note, however, that additional costs of PPC and cPC separation are not included in this study, meaning that in a real plant, the capital costs of the CO<sub>2</sub>-based polyol process may be higher.

The operational costs are mainly caused by the feedstock (naphtha production and transport (SA 1) and chemicals (SA 5)). The Opex of SA 1 is 15% lower in the CCS and CCUS cases. This is due to naphtha fuel savings as a result of the enhanced heat content of the PSA offgas burned in the reformer furnace (as the CO<sub>2</sub> is captured upstream the PSA unit). This partially compensates for the operational costs of CO<sub>2</sub> capture and compression in the CCS and CCUS cases. The Opex of the

**Table 10**

Pedigree scores for economic input data. The dashes (–) are due to only operational cost for that system area.

	Proxy	Reliability of source	Completeness (only equipment)	Completeness (other parameter)	Validation process
<b>SA 1: Naphtha production and transport</b>					
Capex	–	–	–	–	–
Opex	3	1	–	3	0
<b>SA 2a: H<sub>2</sub> unit without CO<sub>2</sub> capture</b>					
Capex	–	2	–	–	–
Opex	3	3	–	2	0
<b>SA 2b: CO<sub>2</sub> capture unit</b>					
Capex	–	2	2	3	2
Opex	3	3	–	2	0
<b>SA 3: CO<sub>2</sub> transport and storage</b>					
Capex	–	2	1	3	1
Opex	–	2	–	2	1
<b>SA 4a: Conventional polyol</b>					
Capex	–	2	1	3	1
Opex	–	3	–	2	0
<b>SA 4b: CO<sub>2</sub>-based polyol</b>					
Capex	–	2	1	3	1
Opex	–	3	–	2	0
<b>SA 5: Chemicals</b>					
Capex	–	–	–	–	–
Opex	3	3	–	2	0

H<sub>2</sub> unit (SA 2b) of the CCS and CCUS cases is a factor of 3.7 higher than in the reference case because of the energy penalty of CO<sub>2</sub> capture and compression. Replacing part of the PO by CO<sub>2</sub> reduces the Opex of CO<sub>2</sub>-polyol production by 14% with respect to the conventional route. The savings in PO feedstock in the CCUS case compensate for the extra operational costs due to CO<sub>2</sub> capture, transport and storage. Consequently, the CCUS case has the lowest total Opex among all cases.

The Opex for storage in the CCUS case is 10% lower than in the CCS case, which is proportional to the amount of CO<sub>2</sub> stored. However, the Opex for transport in the CCUS case is higher than in the CCS case because it requires additional pump work due to higher pressure drop. Details on transport and storage costs are available in the Supplementary material.

### 3.2.1. Uncertainty analysis

The pedigree scores assigned to the economic input data are shown in **Table 10**. The scores of the criterion *Proxy* were the highest and the ones for the *Reliability of source* were intermediate. The Capex input data was derived from independent open literature and therefore scored a 2. The Opex input data sources were qualified estimates by industrial experts supported by industry data and therefore it scored a 3. However, CO<sub>2</sub> transport and storage scores a 2 since the Opex was based on the ZEP reports (2011) [31,45], which include inputs from industrial partners, but do not explicitly constitute an industrial quote and assumptions are not fully documented. *Completeness of equipment* scored relatively low since only the major units were included in the equipment list. This is typical practice in the early phases of a project, when the initial feasibility is evaluated and rough choices about design alternatives are made. Input data for the other parameters included in the Capex estimation was mostly complete. As already indicated in the technical assessment, the *Validation* criterion had the largest uncertainties. The Capex of the H<sub>2</sub> and the capture units were validated against independent cost estimation of the same equipment and scope. However, due to scarce availability of real project data on polyol systems, they scored 1 in the Capex validation. Opex data was taken from only one source and not compared with other independent data. Although the *Reliability* of the sources is appropriate (pedigree score of 3), the values were not validated and therefore they scored a 0.

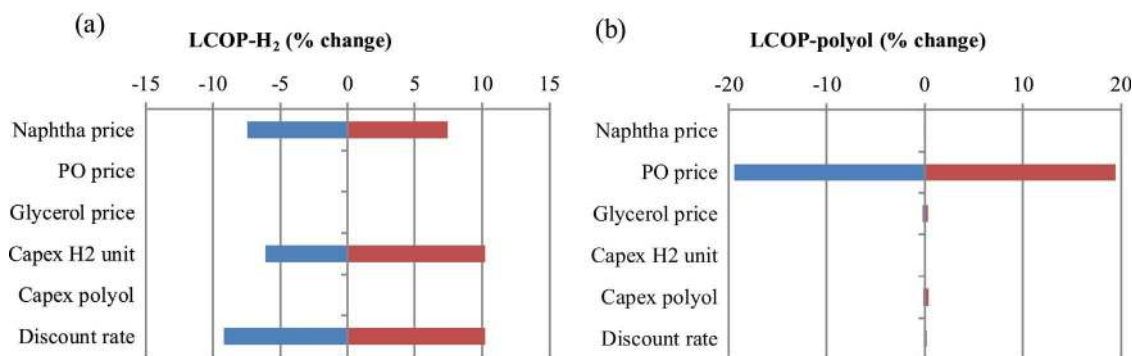

Fig. 4. Tornado diagram: sensitivity of LCOP to selected input parameters. (a) Hydrogen. (b) Polyol.

The sensitivity analysis shows that the economic parameters have different impact in the LCOP of the hydrogen and the polyol (Fig. 4). Both product costs are largely affected by the price of their respective major feedstocks (naphtha and PO), although the LCOP of the polyol is twice as sensitive as the hydrogen one ( $\pm 19\%$  and  $\pm 8\%$ , respectively). Whereas the LCOP of H<sub>2</sub> is also affected by changes in the Capex and the discount rate, the LCOP of the polyol is stable against variations in these economic parameters. Although the accuracy of the baseline value of the Capex for the polyol plant was  $-30\%$  to  $+50\%$ , the sensitivity analysis shows that those inaccuracies have no impact on the final product costs. The LCOP of polyol is directly influenced by the PO price but this does not negatively affect the competitiveness of the CO<sub>2</sub>-polyols. Since PO is also the feedstock for the synthesis of conventional polyol, at higher prices of PO, the CO<sub>2</sub>-polyol process will have a larger economic advantage over the traditional route.

### 3.3. Environmental assessment

Selected key environmental indicators are shown in Table 11. The full list of results for the seven impact categories assessed are in Appendix C.

Fig. 5 shows the environmental burdens of the three cases, broken into contributions from the system areas, relative to the reference case. Typical trends of CCS scenarios are observed, where advantages in climate change impacts are identified for CCS over the reference scenario, but moderate increases in other environmental impact categories. Overall, an improvement of the CCUS case over the reference is observed in all but one impact category, *i.e.*, photochemical oxidant formation (POF). This implies an overall conclusion that CCUS appears to have an improved environmental performance over both the REF and the CCS cases for the impact categories evaluated. However, the differences range between 2 and 14% improvement over the REF case and may in some cases potentially fall within uncertainty margins.

From the figure, the REF and CCS cases show similar impacts in terrestrial acidification (TA), freshwater eutrophication (FE), particular matter formation (PMF) and human toxicity (HT). In both cases, these

Table 11

Environmental performance indicators of the REF, CCS, and CCUS systems per functional unit of 1 MJ H<sub>2</sub>, 0.03 kg polyols and 0.187 kg low pressure steam. NMVOC: non-methane volatile organic carbon.

Performance indicator	Acronym	Units	REF	CCS	CCUS
Climate change	CC	kg CO <sub>2</sub> eq	2.6E-1	2.2E-1	2.0E-1
Photochemical oxidant formation	POF	kg NMVOC	8.0E-4	8.9E-4	8.3E-4
Fossil depletion	FD	kg oil eq	1.0E-1	1.1E-1	9.8E-2

impacts are dominated by the higher demand of polyol precursors in the conventional polyol synthesis used in both of these cases. The use of these polyol precursors are reduced by use of captured CO<sub>2</sub> in the CCUS case and is evident in the lower SA 5 impacts in these categories. On the other hand, the carbon capture process induces similar trends in CC, POF and FD impacts for the CCS and CCUS cases. These arise from the carbon capture process (SA 2), which reduces the CC impact relative to the REF case, but increases relative POF impacts because the PSA offgas, which is released to the atmosphere, is richer in CO.

As shown in Fig. 5, the naphtha value chain, H<sub>2</sub> production unit, and the chemicals value chain (SA 1, 2, and 5, respectively) dominate the impacts. Within each of these system areas, a few key processes contribute to the majority of the environmental impacts. From the contribution analysis and structural path analysis, the production of propylene oxide reactant in SA 5 is a major source of emissions for conventional polyol synthesis in the REF and CCS cases. In particular, these methods indicate that important contributions to all of the impact categories for SA 5 include the direct emissions from the production of propylene oxide and its precursors (chlorine, sodium hydroxide, propylene) and their required energy of production, which is partially sourced from coal. Naphtha production and transport (SA1) for all cases is also a key contributor, particularly to PMF and FD, while the combustion of naphtha and steam reforming in SA 2 (H<sub>2</sub> unit) are the dominant processes contributing to CC and POF.

The CCS case presents a slight increase in most of the impact categories relative to the reference case. The reduction in naphtha fuel consumption in the furnace due to higher heating value of the PSA offgas (post-CO<sub>2</sub> capture) does not fully compensate for the increase on the impacts associated with the extra fuel required for the capture unit and the electricity needed for CO<sub>2</sub> compression. In the CCUS case, CO<sub>2</sub> replaces part of the energy intensive PO feedstock for polyol synthesis, offsetting the increase of energy consumed due to the capture unit and compression train. As a consequence, all of the investigated impacts in the CCUS case decrease relative to the reference and CCS cases, with the exception of POF. A complete list of the seven indicators included in the environmental assessment can be found in Appendix C.

#### 3.3.1. Uncertainty analysis

The uncertainty of the LCI is evaluated in Table 12 below. The evaluation criteria can be found in Appendix D. Infrastructure for SA 1, 3 and 5 are modelled from *ecoinvent* and therefore not as highly rated due to differences in some of the correlation parameters and some missing flows. Similarly, the operations part of the LCI for SA 1 and SA 5 modelled from *ecoinvent* are not completely representative of the cases studied here. From the table, it can be seen that the chemicals used in the facility (SA 5), show the lowest scores, representing a lack of available and representative data to model the required chemicals. In particular, proxy chemicals were necessary to model the DMC catalyst and the ADIP-X solvent, and the database processes used for the propylene oxide, monopropylene glycol and glycerol are somewhat

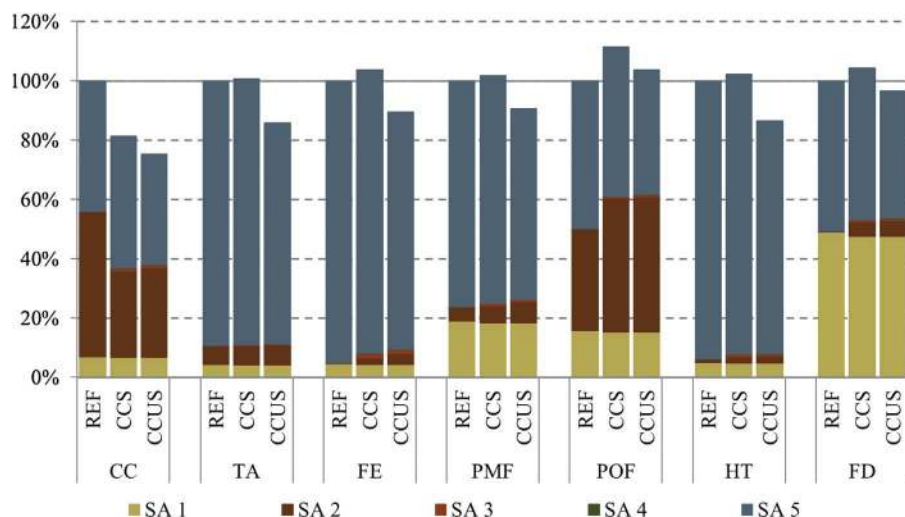

Fig. 5. Contribution analysis for all cases, relative to the reference case (%). SA 1: Naphtha production and transport; SA 2: H<sub>2</sub> unit with or without carbon capture; SA 3: CO<sub>2</sub> transport and storage; SA 4: Polyol synthesis; SA 5: Chemicals.

Table 12  
Pedigree scores for environmental LCI.

	Reliability of source	Completeness	System representativeness	Temporal correlation	Geographical correlation
<b>SA 1: Naphtha production and transport</b>					
Operation	3	3	3	2	2
Infrastructure	3	2	3	2	2
<b>SA 2a: H<sub>2</sub> unit without CO<sub>2</sub> capture</b>					
Operation	3	3	3	3	3
Infrastructure	3	3	3	3	3
<b>SA 2b: H<sub>2</sub> unit with CO<sub>2</sub> capture</b>					
Operation	3	3	3	3	3
Infrastructure	3	3	3	3	3
<b>SA 3: CO<sub>2</sub> transport and storage</b>					
Operation	3	3	3	3	3
Infrastructure	3	2	2	2	2
<b>SA 4a: Conventional polyol</b>					
Operation	2	3	3	3	3
Infrastructure	2	3	3	3	3
<b>SA 4b: CO<sub>2</sub>-based polyol</b>					
Operation	1	3	3	3	3
Infrastructure	1	3	3	3	3
<b>SA 5: Chemicals</b>					
Operation	3	2	2	2	2
Infrastructure	2	2	2	2	2

outdated and incomplete. This same SA is a significant contributor to all of the studied impact categories (Fig. 5), which indicates an incentive to obtain higher quality data for the chemicals used in this system.

Due to the novelty of the technology, the CO<sub>2</sub>-polyol system area received low scores in *Reliability*. This is a reflection of the low scores received for this system area in the technical and economic performance parameters. However, the results presented in Fig. 5 indicate negligible contribution of the CO<sub>2</sub>-polyol system area to overall impact in the investigated categories, so the low scores in for this system area are of less concern. The remaining system areas score fairly high as these were based on the technical modelling, which was specific to the plants studied.

The differences in results between REF, CCS and CCUS cases are generally small, and given the uncertainty assessment, the conclusion that CCUS is the environmentally superior option should be used carefully.

#### 4. Conclusions

A detailed technical, economic, and environmental impact

assessment combined with uncertainty analysis was carried out to evaluate the feasibility of using CO<sub>2</sub> captured from a hydrogen manufacturing unit at a refinery complex. In the CCUS case, 10% of the total captured CO<sub>2</sub> is utilised in polyol synthesis while the remainder of the CO<sub>2</sub> is stored. The results show that this combination of CCUS and CCS can provide a feasible option to reduce the CO<sub>2</sub> emissions associated with this type of refinery operations while improving the business case. From an economic point of view, a refinery could choose to build a small capture unit to satisfy the CO<sub>2</sub> demand for polyol synthesis. In this case, all of the captured CO<sub>2</sub> would be used and partial storage would not be needed. The capture unit would be significantly smaller, and there would be no transport and storage costs. However, economies of scale might have a negative impact on the costs and the refinery will not profit from naphtha savings. This alternative case was not included in the present study because it would effectively only represent a 10% reduction in total CO<sub>2</sub> emissions for the system and the cases were defined with large CO<sub>2</sub> emission reductions goals.

When capturing all CO<sub>2</sub> emitted at a H<sub>2</sub> unit of a refinery, both CO<sub>2</sub> emissions and the amount of naphtha fuel used in the reformer furnace decrease (65 wt% and 14 wt% with respect to the reference case, respectively). By utilising the captured CO<sub>2</sub> in polyol synthesis, propylene oxide demand decreases with 17 wt% compared to the conventional polyol synthesis. These factors have a large impact in the comparison of the economic and environmental performance of the three cases included in this research.

From the H<sub>2</sub> unit perspective, the savings in naphtha fuel are not large enough to compensate for the extra costs of the capture unit and compression train required in the CCS and CCUS cases. The LCOP of H<sub>2</sub> is 7.8 and 7.7 €/GJ H<sub>2</sub> in the CCS and CCUS cases, respectively. This value is 58% (CCS case) and 55% (CCUS case) higher with respect to the reference case in which no CO<sub>2</sub> is captured. However, the levelised costs of polyol decrease to 1.2 €/kg polyol in the CCUS case, 16% lower than in the conventional process. A break-even analysis carried out at the system level showed that the reduced costs of the CO<sub>2</sub>-polyol in the CCUS case compensate for the increase in H<sub>2</sub> costs, thus making the CCUS case more economically attractive than the reference case. However, a minimum CO<sub>2</sub> cost of 47 €/t would be required for making the CCS case more cost-effective than the reference case. The results indicate that using 10% of the total CO<sub>2</sub> captured from the refinery and storing the rest of the CO<sub>2</sub> presents an interesting business case for refineries because expensive PO feedstock is replaced by waste CO<sub>2</sub>. CO<sub>2</sub> utilisation in combination with partial storage provides an economic advantage compared to storage alone and to a reference case

without CO<sub>2</sub> capture. The uncertainty analysis shows that these economic results are robust because the most uncertain system areas (polyol production excluding feedstock costs) have low impact on the overall economics.

The environmental assessment revealed that the introduction of the CCUS process in the hydrogen unit in combination with storage of the remaining CO<sub>2</sub> reduces the climate change impacts by 23% compared to the reference case. Of the other 6 environmental impact categories included in the LCA, all but one (POF) present slightly better performance in the utilisation case than in the reference case where no CO<sub>2</sub> is captured. However, the differences between the three cases are approximately 15%, indicating relatively small differences in environmental performance outside of CC. Propylene oxide feedstock used in the polyol synthesis, and its precursors, the naphtha value chain and naphtha combustion are identified as a particularly environmentally intensive contributors in this system. Given the uncertainties in the model, the environmental determination of the investigated systems remains inconclusive.

## Appendix A. Technical modelling

The Peng-Robinson equation of state, which is appropriate for hydrocarbon systems, was used in the modelling of the H<sub>2</sub> unit in the Aspen Plus software. A Gibbs free energy reactor was used to model the reformer, and for the WGS a stoichiometric reactor with a conversion of 0.74 of the component CO (refinery data). The outputs of the models of the H<sub>2</sub> unit without capture were validated against data from a real refinery in Asia (Table A1). The H<sub>2</sub> unit of the real refinery does not include a capture unit.

A review of the technical design values of the polyol synthesis reported in the literature was performed [12–18] and together with experts in polyol R & D and manufacturing [21] specific values shown in Table A2 were used to develop the polyol models. Details on the literature review, explanation of the values selected and the spreadsheet calculation performed for polyol synthesis are in the Supplementary material.

The overall mass and energy balances of the reference, CCS and CCUS cases are shown in Table A3.

The mass and energy balances of the H<sub>2</sub> unit with and without are shown in Table A4.

The mass and energy balances of the polyol synthesis are shown in Table A5.

**Table A1**  
Technical model validation of the H<sub>2</sub> unit. % Deviation from real refinery data.

Model parameter	Syngas before WGS	PSA inlet
Δ(Total flow)	< 1%	– 1%
Δ(Pressure)	< 1%	– 2%
Δ(Temperature)	< 1%	< 1%
Δ(Mass fraction)	< 1%	< 1%
Δ(H <sub>2</sub> O)	< 1%	< 1%
Δ(H <sub>2</sub> )	< 1%	< 1%
Δ(CO)	< 1%	< 1%
Δ(CO <sub>2</sub> )	< 1%	– 1%
Δ(CH <sub>4</sub> )	< 1%	1%
Δ(Naphtha)	< 1%	< 1%

**Table A2**  
Technical values used in the polyol models.

Parameter	Units	Conventional	CO <sub>2</sub> -based	Source
Polyol functionality	–	2.8	2.8	Eleveld [21]
Starter	MPG/G	20/80	20/80	based on polyol functionality
Heat of reaction	kJ/mol	81	64	Eleveld [21]
CO <sub>2</sub> excess	%	–	40	Haider et al. [14]
Catalyst type	–	DMC	DMC	all references used for the model <sup>a</sup>
Catalyst amount	ppm	150	150	Eleveld [21]
Polyol selectivity	%	100	94	von der Assen and Bardow [18]
cPC selectivity	%	0	6	von der Assen and Bardow [18]
Molecular weight	kg/kmol	3200	3938	model output

**Table A3**  
Overall mass and energy balance of the reference, CCS and CCU cases.

Materials	Units	REF	CCS	CCUS
Naphtha feed	kt/a	234	234	234
HP steam feed	kt/a	1 083	1 083	1 083
Propylene Oxide	kt/a	243	243	202
Mono Propylene Glycol	kt/a	2	2	2
Glycerol	kt/a	5	5	5
Utilities				
LP steam	kt/a	– 1 727	– 1 126	– 1 117
Cooling water	kt/a	11 251	24 422	24 364
Chilled water	kt/a	169	169	138
Electricity	kW	1 920	7 454	7 576

**Table A4**  
Mass and energy balance of the H<sub>2</sub> unit. With and without capture.

CO <sub>2</sub> flows	Units	No capture	
Capture			
CO <sub>2</sub> emissions	kg/kg H <sub>2</sub>	12	4
CO <sub>2</sub> captured	kg/kg H <sub>2</sub>	–	7
Materials & Utilities	Units	No capture	
Capture			
HP steam feed	kg/kg H <sub>2</sub>	14	14
Naphtha feed	kg/kg H <sub>2</sub>	3	3
Naphtha fuel	kg/kg H <sub>2</sub>	0.91	0.78
Naphtha avoided	kg/kg H <sub>2</sub>	–	0.13
Net LP steam consumed	kg/kg H <sub>2</sub>	– 23	– 15
Cooling water	kg/kg H <sub>2</sub>	7	308
Electricity	kWh/kg H <sub>2</sub>	0.16	0.73

**Table A5**  
Mass and energy balance of polyol synthesis. Conventional and CO<sub>2</sub>-based.

Materials	Units		
Conventional	CO <sub>2</sub> -based		
CO <sub>2</sub> utilised	kg/kg polyol	–	0.23
PO consumption	kg/kg polyol	0.97	0.81
G consumption	kg/kg polyol	0.02	0.02
MPG consumption	kg/kg polyol	0.01	0.01
Utilities	Units		
Conventional	CO <sub>2</sub> -based		
Cooling water	kg/kg polyol	1.43	1.14
Chilled water	kg/kg polyol	0.68	0.55
Steam	kg/kg polyol	0.02	0.05
Electricity	kWh/kg polyol	0.01	0.01

## Appendix B. Economic modelling

For economic data used in the modelling see [Tables B1–B5](#).

Utility costs were estimated based on historical data adjusted for inflation. Labour costs were estimated based on the amount of operators and

engineers per SA and their individual costs per year. Wage information was retrieved from the Norwegian Confederation of Trade Unions [29] and the Confederation of Norwegian Enterprises [30]. The same manning was assumed for the conventional and CO<sub>2</sub>-based polyol plants, one extra engineer and one extra operator shift were added for the capture unit. One shift rotation contains six operators.

**Table B1**  
Chemicals price.

Chemical	Price (€/t)	Source
Naphtha	480	Quotenet [52]
PO	1400	ICIS [53]
MPG	1550	Proxy, 150 €/t higher than PO
Glycerol	730	Scott et al. [54]

**Table B2**  
Utilities costs.

Utility	Units	Cost	Source
Naphtha	€/tonne	480	Quotenet [52]
Cooling water	€/m <sup>3</sup>	0.025	Sinott [55]
Steam	€/tonne	21.25	Sinott [55]
Electricity	€/kWh	0.10	Eurostat [56]

**Table B3**  
Salary of operators and engineers.

	Units	Operator	Engineer
Number employers per shift	–	6	1
Yearly salary per employee	k€	62	100
Insurance, extras	k€	22	37.5
Total per employee	k€	84	137.5

**Table B4**  
Labour costs.

System area	Manning		Costs (k€/a)	
	Operator	Engineer	Operator	Engineer
H <sub>2</sub> without capture	2	2	1012	276
H <sub>2</sub> with capture	3	3	1520	414
Conventional polyol	1	1	506	138
CO <sub>2</sub> -polyol	1	1	506	138

**Table B5**  
Economic modelling assumptions.

Item	Units	Value
Project lifetime	years	25
Construction time	years	3
Real discount rate	%	7.5

## Appendix C. Environmental modelling

The complete list of the environmental indicators is shown in [Table C1](#).

**Table C1**  
Environmental indicators.

Performance indicator		Units	REF	CCS	CCUS
Climate Change	CC	kg CO <sub>2</sub> eq	2.6E-1	2.2E-1	2.0E-1
Terrestrial Acidification	TA	kg SO <sub>2</sub> eq	7.1E-4	7.2E-4	6.5E-4
Freshwater Eutrophication	FE	kg P eq	6.2E-5	6.5E-5	5.6E-5
Particulate Matter Formation	PMF	kg PM <sub>10</sub> eq	3.1E-4	3.1E-4	2.8E-4
Photochemical Oxidant Formation	POF	kg NMVOC eq	8.0E-4	8.9E-4	8.3E-4
Human Toxicity	HT	kg 1.4 DB eq	3.5E-2	3.5E-2	3.0E-2
Fossil Depletion	FD	kg oil eq	1.0E-1	1.1E-1	9.8E-2

## Appendix D. Pedigree matrices

Uncertainty analysis was performed using pre-defined pedigree matrices for each research area. See [Tables D1–D5](#).

**Table D1**  
Pedigree matrix for technical input data.

SCORE	Proxy	Empirical basis	Theoretical understanding	Methodological rigour	Validation process
4	A direct measure of the desired quantity	Controlled experiments and large sample, direct measurements	Well established theory	Best available practice in well established discipline	Compared with independent measurements of same variable over long domain
3	Good fit to measure	Historical/field data, uncontrolled experiments, small sample, direct measurements	Accepted theory with partial nature (in view of the phenomenon it describes)	Reliable method common within established discipline; best available practice in immature discipline	Compared with independent measurements of closely related variable over shorter period
2	Well correlated but not measuring the same thing	Modelled/derived data, indirect measurements	Accepted theory with partial nature and limited consensus on reliability	Acceptable method but limited consensus on reliability	Measures are not independent, include proxy variables or have limited domain
1	Weak correlation but commonalities in measure	Educated guesses, indirect approximation, rule of thumb estimate	Preliminary theory	Preliminary methods, unknown reliability	Weak and very indirect validation
0	Not correlated and not clearly related	Crude speculation	Crude speculation	No discernable rigour	No validation performed

**Table D2**  
Pedigree matrix for technical submodels.

SCORE	Theoretical understanding	Methodological rigour	Modelling resources	Validation process
4	Well established and accepted theory	Best available practice in well-established discipline	High expertise from multiple practitioners in subject matter and minimal time constraints	The (sub)model as a whole has been compared with independent measurements
3	Accepted theory with partial nature (in view of the phenomenon it describes)	Reliable method common within established discipline; Best available practice in immature discipline	Good expertise from single practitioner and minimal time constraints	Parts of the (sub)model have been compared with independent measurements
2	Accepted theory with partial nature and limited consensus on reliability	Acceptable method but limited consensus on reliability	Limited expertise but enough time to build skill for the specific purpose; medium to high expertise but constrained in time	Measures are not independent, include proxy variables or have limited domain
1	Preliminary theory	Preliminary methods; unknown reliability	Limited expertise and limited time available	Weak and very indirect validation
0	Crude speculation	No discernable rigour	No expertise in the subject matter and big time constraints	No validation performed



**Table D3**  
Pedigree matrix for economic input data.

SCORE	Proxy	Reliability of source	Completeness (only for equipment list)	Completeness (all other parameters)	Validation process
4	A direct measure of the desired quality	Measured/official industrial, vendor, and/or supplier data	Representative data for all line items (processes, instruments, electro, civil, mechanical, etc.)	Complete data from a large number of samples over a representative period	Compared with independent data from similar systems that have been built
3	Good fit to measure	Qualified estimate by industrial expert supported by industry data	Representative data for all process equipment (equipment list, heat and mass balance, PFD)	Complete data from a large number of samples but for unrepresentative periods or from representative periods but for a small number of samples	Compared with independent data of similar systems that have not been built
2	Correlated but does not measure the same thing	Reviewed data derived from independent open literature	Representative data for most important process equipment (equipment list, heat and mass balance, PFD)	Almost complete data but from a small number of samples or for unrepresentative periods or incomplete data from adequate number of samples and periods	Validation measurements are not independent, include proxy variables or have limited domain
1	Weak correlation but commonalities in measure	Non-reviewed data from open literature	Data from an adequate number process parameters (heat and mass balance, PFD)	Almost complete data but from a small number of samples and unrepresentative periods	Weak and indirect validation
0	Not correlated and not clearly related	Non-qualified estimate or unknown origin	Only high level or incomplete data available	Incomplete data from a small number of samples for an unrepresentative period	No validation performed

**Table D4**  
Pedigree matrix for environmental LCI.

SCORE	Reliability of source	Completeness	System representativeness	Temporal correlation	Geographical correlation
4	Verified data based on measurements	Data for all value chain processes and flows	Exact data on processes and materials under study	Less than 2 years of difference	Data from area under study
3	Verified data partly based on assumptions or non-verified data based on measurements	Data for all flows from adequate value chain processes	Data on processes and materials based on same technology	Less than 5 years of difference	Data from area with similar production conditions
2	Non-verified data partly based on assumptions	Data for adequate flows from adequate value chain processes	Data on processes and materials based on analogous technology	Less than 10 years of difference	Average data from larger area in which the area under study is included
1	Qualified estimate	Data for limited value chain processes or flows	Data on processes and materials based on different technology	Less than 15 years of difference	Data from area with slightly similar production conditions
0	Non-qualified estimate or unknown origin	Incomplete data or no details	Data on different processes or materials	Age of data unknown or more than 15 years of difference	Data from unknown area or area with different production conditions

## Appendix E. Supplementary data

Supplementary data associated with this article can be found, in the online version, at <http://dx.doi.org/10.1016/j.jcou.2017.08.005>.

## References

- [1] IEA, CCS 2014. What Lies in Store for CCS? (2014).
- [2] M. Cuéllar-Franca, A. Azapagic, Carbon capture, storage and utilisation technologies: a critical analysis and comparison of their life cycle environmental impacts, *J. CO<sub>2</sub> Util.* (2015) 82–102, <http://dx.doi.org/10.1016/j.jcou.2014.12.001>.
- [3] SETIS, Carbon Capture, Utilization and Storage. SETIS Magazine of the European Commission, (2016).
- [4] W. Schakel, G. Oreggioni, B. Singh, A.H. Strømman, C.A. Ramírez, Assessing the techno-environmental performance of CO<sub>2</sub> utilization via dry reforming of methane for the production of dimethyl ether, *J. CO<sub>2</sub> Util.* 16 (2016) 138–149, <http://dx.doi.org/10.1016/j.jcou.2016.06.005>.
- [5] P. Markewitz, W. Kuckshinrichs, W. Leitner, J. Linssen, P. Zapp, R. Bongartz, A. Schreiber, T.E. Muller, Worldwide innovations in the development of carbon capture technologies and the utilization of CO<sub>2</sub>, *Energy Environ. Sci.* 2012 (5) (2012) 7281–7305, <http://dx.doi.org/10.1039/c2ee03403d>.
- [6] S.J. Bennett, D.J. Schroeder, S.T. McCoy, Towards a framework for discussing and assessing CO<sub>2</sub> utilisation in a climate context, *Energy Procedia* 63 (2014) 7976–7992, <http://dx.doi.org/10.1016/j.egypro.2014.11.835>.
- [7] IEA, UNIDO, Technology Roadmap: Carbon Capture and Storage in Industrial Applications, (2011).
- [8] Air products, News Release: Air Products Celebrates Texas Carbon Capture Demonstration Project Achievement, (2013) <http://www.airproducts.com/Company/news-center/2013/05/0510-air-products-celebrates-texas-carbon-capture-demonstration-project-achievement.aspx>.
- [9] Shell, Media Release: Shell Launches Quest Carbon Capture and Storage Project, (2015) <http://www.shell.com/media/news-and-media-releases/2015/shell-launches-quest-carbon-capture-and-storage-project.html>.
- [10] J.C. Meerman, E.S. Hamborg, T. van Keulen, A. Ramírez, W.C. Turkenburg,

- A.P.C. Faaij, Techno-economic assessment of CO<sub>2</sub> capture at steam methane reforming facilities using commercially available technology, *Int. J. Greenhouse Gas Control* 9 (2012) 160–171, <http://dx.doi.org/10.1016/j.ijggc.2012.02.018>.
- [11] M. Pérez-Fortes, E. Tzimas, Carbon capture and utilisation – synthesis of fuels, chemicals and materials, *SETIS Mag.* 11 (2016) 43–45 <https://setis.ec.europa.eu/publications/setis-magazine/carbon-capture-utilisation-and-storage/carbon-capture-and-utilisation-%E2%80%93>
- [12] D.J. Darensbourg, S.J. Wilson, What's new with CO<sub>2</sub>? Recent advances in its copolymerization with oxiranes, *Green Chem.* 14 (2012) 2665–2671, <http://dx.doi.org/10.1039/c2gc35928f>.
- [13] J. Langanke, A. Wolf, J. Hofmann, K. Böhm, M.A. Subhani, T.E. Müller, W. Leitner, C. Gürtler, Carbon dioxide (CO<sub>2</sub>) as sustainable feedstock for polyurethane production, *Green Chem.* 16 (2014) 1865–1870, <http://dx.doi.org/10.1039/C3GC41788C>.
- [14] K.W. Haider, K.G. Mcdaniel, J.E. Hayes, J. Shen, Polyether Carbonate Polyols Made via Double Metal Cyanide (DMC) Catalysis, (2008) (WO 2008013731 A1).
- [15] D. Mijolovic, M. Kummeter, M. Stoesser, S. Bauer, S. Goettke, Process for Preparing Polyether Carbonate Polyols, (2012) (US 8324419 B2).
- [16] J. Hofmann, C. Gürtler, S. Grasser, A. Wolf, Process for the Production of Polyether Carbonate Polyols, (2014) (US2014/0256908A1).
- [17] T.E. Müller, C. Gürtler, M.A. Subhani, Method for Producing Polyether Carbonate Polyols, (2014) (US 20140323670 A1).
- [18] N. von der Assen, A. Bardow, Life cycle assessment of polyols for polyurethane production using CO<sub>2</sub> as feedstock: insights from an industrial case study, *Green Chem.* 16 (2014) 3272, <http://dx.doi.org/10.1039/c4gc00513a>.
- [19] GCCSI, The Global Status of CCS: 2011, Global CCS Institute, Canberra, Australia, 2011.
- [20] EDDiCCUT, Environmental Due Diligence of CO<sub>2</sub>, (2012) [www.eddiccut.com](http://www.eddiccut.com).
- [21] M. Eleveld, Shell, Personal Communication, (2015).
- [22] Bio-based news, Bio-based News, (2016) <http://news.bio-based.eu/premiere-for-new-raw-material-covestro-launches-industrial-production-of-plastics-using-carbon-dioxide/>.
- [23] A. Prokofyeva, C. Gürtler, CO<sub>2</sub> as building block for the chemical industry, United Nations Climate Change Conference, Bonn, Germany, 2014 [https://unfccc.int/files/bodies/awg/application/pdf/04\\_bayer\\_angelina\\_prokofyeva.pdf](https://unfccc.int/files/bodies/awg/application/pdf/04_bayer_angelina_prokofyeva.pdf).
- [24] P. Spath, A. Aden, T. Eggeman, M. Ringer, B. Wallace, J. Jechura, Biomass to Hydrogen Production. Detailed Design and Economics Utilizing the Battelle Columbus Laboratory Indirectly-Heated Gasifier, National Renewable Energy Laboratory, 2005 (Technical Report NREL/TP-510-37408).
- [25] O. Nuyken, S.D. Pask, Ring-opening polymerization—an introductory review, *Polymers* 5 (2013) 361–403, <http://dx.doi.org/10.3390/polym5020361>.
- [26] R.T. Sanderson, Polar Covalence. Chapter 4-Multiple Bonds, Academic Press, Elsevier, 1991, pp. 53–68.
- [27] G. Towler, R. Sinnott, Capital Cost Estimating. *Chem Eng Des Princ Pract Econ Plant Process Des.* second ed., Oxford, Butterworth-Heinemann, 2013.
- [28] E.S. Rubin, C. Short, G. Booras, J. Davison, C. Ekstrom, M. Matuszewski, S. McCoy, A proposed methodology for CO<sub>2</sub> capture and storage cost estimates, *Int. J. Greenhouse Gas Control* 17 (2013) 488s–503s.
- [29] LO, Norwegian Confederation of Trade Unions, (2014) [www.lo.no/lonn-tariff](http://www.lo.no/lonn-tariff).
- [30] NHO, Confederation of Norwegian Enterprise, (2014) <https://www.nho.no/en>.
- [31] ZEP, The Costs of CO<sub>2</sub> Storage: Post-demonstration CCS in the EU, Zero Emissions Platform, IEAGHG, 2011.
- [32] M.W. van der Spek, E. Sanchez Fernandez, N.H. Eldrup, R. Skagestad, C.A. Ramirez, A.P.C. Faaij, Unravelling uncertainty and variability in early stage techno-economic assessments of carbon capture technologies, *Int. J. Greenhouse Gas Control* 56 (2016) 221–236, <http://dx.doi.org/10.1016/j.ijggc.2016.11.021>.
- [33] L. Shen, J. Haufe, M.K. Patel, Product Overview and Market Projection of Emerging Bio-based Plastics. Final Report PRO-BIP 2009, Group Science, Technology and Society, Utrecht, the Netherlands, 2009.
- [34] SETIS Magazine, Carbon Capture Utilisation and Storage 11 (2016) 43–45 [https://setis.ec.europa.eu/system/files/setis-magazine\\_11\\_ccus\\_final.pdf](https://setis.ec.europa.eu/system/files/setis-magazine_11_ccus_final.pdf).
- [35] C.T. Hendrickson, L.B. Lave, H.S. Matthews, Environmental Life Cycle Assessment of Goods and Services: An Input-output Approach, *Resour. for the Future*, Washington, D.C., 2006.
- [36] G.P. Peters, E.G. Hertwich, Structural analysis of international trade: environmental impacts of Norway, *Econ. Syst. Res.* 18 (2) (2006) 155–181.
- [37] ReCiPe, Mid/Endpoint Method Version 1.11, (2012).
- [38] Ecoinvent, Ecoinvent Data v.3.2, (2015) [www.ecoinvent.ch](http://www.ecoinvent.ch).
- [39] A. Tukker, A. de Koning, R. Wood, T. Hawkins, S. Lutter, J. Acosta, J.M. Rueda Cantuche, M. Bouwmeester, J. Oosterhaven, T. Drosowski, T.J. Kuennen, Exiopol – development and illustrative analyses of a detailed global MR EE SUT/IOT, *Econ. Syst. Res.* 25 (1) (2013) 50–70, <http://dx.doi.org/10.1080/09535314.2012.761952>.
- [40] P. Klopogge, J.P. van der Sluijs, A.C. Petersen, A method for the analysis of assumptions in model-based environmental assessments, *Environ. Modell. Software* 26 (2011) 289–301, <http://dx.doi.org/10.1016/j.envsoft.2009.06.009>.
- [41] M. van der Spek, A. Ramirez, A. Faaij, Improving model uncertainty evaluation by using pedigree matrices. A case study on CO<sub>2</sub> capture with monoethanolamine, *Comput. Chem. Eng.* 85 (2016) 1–15, <http://dx.doi.org/10.1016/j.compchemeng.2015.10.006>.
- [42] P. Christensen Dysert, L.R. Dysert, AACE International Recommended Practice 18R-97 – Cost Estimate Classification System –As Applied in Engineering, Procurement and Construction for the Process Industries, Morgantown, West Virginia, 2005.
- [43] I. Dimitriou, P. Garcia-Gutierrez, R.H. Elder, R.M. Cuellar-Franca, A. Azapagic, R.W.K. Allen, Carbon dioxide utilisation for production of transport fuels: process and economic analysis, *Environ. Sci.* 8 (2015) 1775–1789, <http://dx.doi.org/10.1039/c4ee04117h>.
- [44] G. Centi, S. Perathoner, CO<sub>2</sub>-based energy vectors for the storage of solar energy, *Greenhouse Gas Sci. Technol.* 1 (2011) 21–35, <http://dx.doi.org/10.1002/ghg3.3>.
- [45] ZEP, The Costs of CO<sub>2</sub> Transport: Post-demonstration CCS in the EU, Zero Emissions Platform, IEAGHG, 2011.
- [52] Quotenet, Quotenet, (2015) <http://www.quotenet.com/commodities/naphtha>.
- [53] ICIS, Propylene Oxide: Miscellaneous, FD NEW Contract Price Assessment from 30 to 10-2005 to 30-11-2015. Data file, (2015) (Retrieved from ICIS Dashboard on 04-11-2015).
- [54] E.L. Scott, M.E. Bruins, J.P.M. Sanders, Rules for the Bio-based Production of Bulk Chemicals on a Small Scale, Biobased Commodity Chem., Wageningen UR, the Netherlands, 2013 [www.vpp.wur.nl/UK/](http://www.vpp.wur.nl/UK/).
- [55] R. Sinott, *Chemical Engineering Design: Coulson and Richardson's Chemical Engineering* vol. 6, (2005).
- [56] Eurostat, Eurostat, (2016) [http://ec.europa.eu/eurostat/statistics-explained/index.php/File:Electricity\\_and\\_gas\\_prices,\\_second\\_half\\_of\\_year,\\_2013%E2%80%9315\\_\(EUR\\_per\\_kWh\).YB16.png](http://ec.europa.eu/eurostat/statistics-explained/index.php/File:Electricity_and_gas_prices,_second_half_of_year,_2013%E2%80%9315_(EUR_per_kWh).YB16.png).



**Cora Fernández-Dacosta** is a researcher at the Copernicus Institute of Sustainable Development at Utrecht University, the Netherlands. Her research focuses in the design, techno-economic and environmental assessment of processes to convert waste streams into products. She is a Chemical Engineer with a Professional Doctorate in Engineering, Process and Equipment design from Delft University of Technology.



**Mijndert van der Spek** studied at Delft University of Technology in the fields of energy systems engineering and chemical engineering. He worked for Shell Chemicals for three years as a polyol plant technologist before returning to academia to pursue a PhD in CO<sub>2</sub> capture, utilisation, and storage.



**Christine Roxanne Hung** is a researcher at the Programme for Industrial Ecology at the Norwegian University of Science and Technology (NTNU) in Trondheim, Norway. She has a Masters in Industrial Ecology from NTNU.



**Gabriel D. Oreggioni** has been working in the field of energy conversion technologies for more than 5 years. His main research interests are related to the technical and environmental assessment of energy production processes. He has a PhD in Chemical Engineering (University of Edinburgh), having focused his dissertation on the optimal design of adsorptive carbon capture processes. Currently he is a researcher at the NTNU Industrial Ecology Program, his main duties involve the development of LCA studies for CO<sub>2</sub> capture and utilisation technologies.



**Ragnhild Skagestad** works in Tel-Tek, a national research institute in Porsgrunn, Norway. In Tel-Tek she works in several projects with tasks including cost estimation, CCS and energy optimization. She completed her Masters of Product Development and Production at NTNU in 2004, and has been working in Tel-Tek since 2006.



**Anders Hammer Strømman** is a professor of industrial ecology in the Department of Energy and Process Engineering at the Norwegian University of Science and Technology (NTNU) in Trondheim, Norway.



**Prashant Udaysinh Parihar** is Manager at Corporate R & D Centre, Bharat Petroleum Corporation Limited, India. He has a Masters in Chemical Engineering from Institute of Chemical Technology, India. He has more than 10 years of experience in research & development in the areas of process development, design of experiments and optimization of refining processes.



**Andrea Ramírez** is full professor of Low Carbon Systems and Technologies at Delft University of Technology and associate professor at the Copernicus Institute, Utrecht University. Her research aims at developing methodologies and tools that build bridges between fundamental research at laboratory scale and the insights needed by stakeholders on potential benefits and impacts of these technologies when implemented. Her research portfolio includes projects that assess the sustainability of novel bio-based materials and chemicals, and novel CO<sub>2</sub> capture and utilization technologies.



**D.T. Gokak** is Chief Manager at Corporate R & D Centre, Bharat Petroleum Corporation Limited, India. He has a Doctorate Degree in Chemistry from M.S. University of Baroda, India. He has more than 30 years of experience in research & development in the areas of Catalysis and Catalytic processes, Fuel Testing, Product Development Biofuels and Bitumen.