

PROTOTYPE DEVELOPMENT PROGRESS TOWARD A 500KV SOLID STATE MARX MODULATOR*

G.E. Leyh, Stanford Linear Accelerator Center, Menlo Park, CA USA

Abstract

This paper examines in closer detail the practical advantages and pitfalls of a solid-state Marx configuration, and explores a design approach with emphasis on performance, wall-plug efficiency, cost of manufacture, availability and ease of service. The paper presents electrical diagrams, mechanical CAD layout and preliminary prototype test data.

INTRODUCTION

Several interesting proposals [1] [2] [3] [4] for solid-state Marx bank modulators have emerged in recent years. Richter-Sand et al [3] have demonstrated a long-pulse 30 cell, 30kV 400A Marx bank at 7.5kW average power with sub-microsecond edge speeds. Casey et al [4] have demonstrated a 5 cell, 50kV design, capable of edge speeds better than 100ns at 24kV and 210A output.

Strategies for optimizing scalability, throughput, efficiency, cost and reliability have yet to be fully explored in the published works. These practical issues will ultimately become of vital concern in evaluating the large-scale feasibility of the Marx bank approach.

DESIGN CONSIDERATIONS

The basic Marx circuit suggested by [3] and [4] is shown in Figure 1. Each Marx 'cell' consists of an energy storage capacitor, an IGBT switch, a free-wheeling diode and a common-mode inductive isolator that distributes the DC prime power to the next cell. An arbitrary number of cells are stacked to obtain the desired output voltage at the load. The input to output voltage transformation ratio is simply equal to the total number of cells.

Scaling Limitations

There must be an ultimate limit to the number of cells in a practical Marx bank design. Several factors come into play here:

- Current inrush from increasing stray capacitance.
- Excessive charging current in the lower isolators.
- Lower efficiency as output impedance increases.
- Decreasing reliability as the number of cells increases.

Single-point Failure Risks

The probability of critical component failure increases directly with the number of cells. In the basic design scheme of Figure 1, the failure of any single IGBT or capacitor will fail the entire modulator by shorting out the input DC power. These critical single-point failures must be eliminated in any practical design with large numbers of cells. The transmission scheme for vital control data and timing fiducials must also be massively parallel in nature, to avoid single-point control-induced failures.

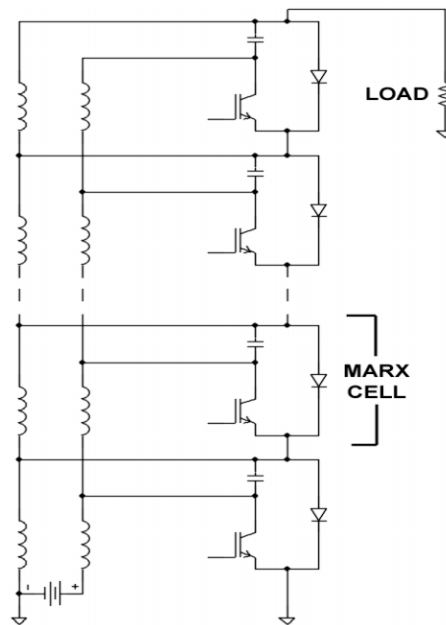

Figure 1: Basic IGBT Marx Design.

Design Robustness

For applications that require long run-times between scheduled maintenance, the modulator must be able to seamlessly 'work around' component failures as they occur during normal operation. In a practical Marx design this requires keeping a certain number of spare cells in 'standby' mode, which the modulator could bring online as needed. The number of spare cells would depend on the length of the desired run-time and the overall reliability of the cells.

DESIGN OPTIMIZATIONS

The design example for this paper is a solid-state 500kV, 550A Marx modulator, operating at 120PPS. Given that the highest voltage IGBT silicon currently available is 6500V, an IGBT-based design will obviously require a large number of cells.

It is possible to construct larger voltage cells by using multiple IGBTs in series within each cell. However this scheme does not ultimately reduce the total number of IGBTs or HV diodes required, and introduces the risk of over-voltage damage to the slowest IGBT within each cell. MOVs or snubbers across each IGBT can reduce this risk, but at increased component expense and switching loss. Using a higher cell count avoids this risk entirely, allows the use of lower DC input voltages, and provides finer control resolution of the output waveform.

* Work supported by the U.S. Department of Energy under contract DE-AC03-76SF00515.

The improved IGBT Marx topology is shown below.

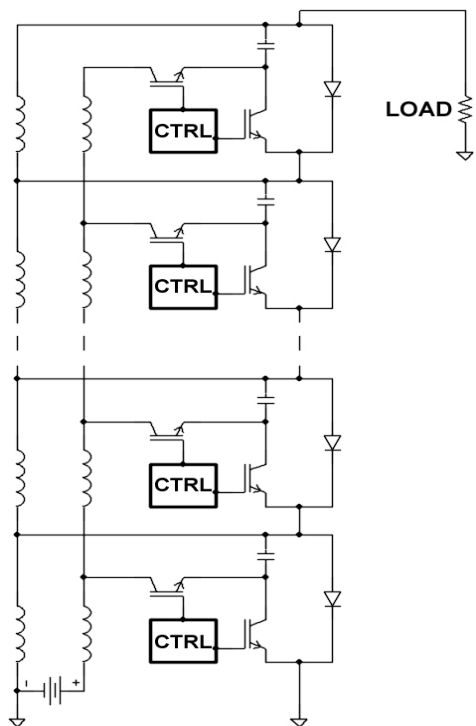

Figure 2: Improved Design with HV Control.

Mitigating Single-point Failures

Failures of any IGBT or capacitor in the basic Marx design of Fig. 1 will fail the entire modulator. These single-point risks are mitigated by adding a simplified high-side IGBT buck regulator to each cell, as shown in Figure 2. This regulator serves three vital functions:

1. Control of inrush currents during the charging cycle.
2. Local regulation of the cell operating voltage.
3. Isolation of the cell from the main DC charging path, in the event of a cell failure.

Each cell receives timing and control signals directly via wideband RF using inexpensive off-the-shelf 2.4GHz telecom chipsets. This avoids the potential single-point failures of a daisy-chained or optically-coupled communications link. Each local cell control circuit also performs real-time corrections of timing skew introduced by its own IGBT, allowing the cells to be automatically synchronized to within a few nS without the need for manual adjustments.

Electric Field Control

Assuming a 500kV risetime of 250nS, electric field movements can reach speeds of 2MV/uS. It is critical not only to minimize the stray capacitance of the cell structures to ground, but to shield the local cell control electronics from these fast electric fields as well.

In order to shield individual cells and to simplify the overall mechanical design, the Marx bank is arranged into 32 individually shielded blocks, as illustrated in Figure 3.

The stack lies horizontally as shown, with a backbone that runs through the center of the stack. The individual

block assemblies weigh about 21kg each and are removed from the top for servicing. The two blocks closest to the klystrons are reserved for klystron utilities, pumps and diagnostics. The klystron filament power is derived by switch-mode converting the local HVDC on the backbone into suitable voltages and currents.

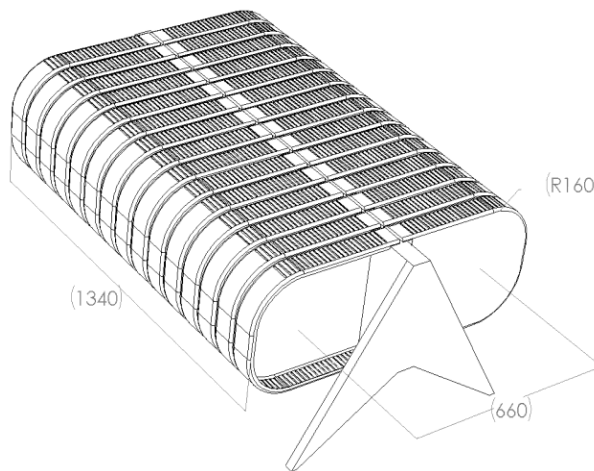

Figure 3: Proposed Marx Modulator. Dimensions in mm.

The outer aluminum casing of each block structure is radiused to minimize the electric field on the outer surface. The total stored energy in the stray stack capacitance at 500kV is about 5J, and the two klystron cathodes contribute approximately 25J total.

Block-level Integration

Each block generates 18kV total from its 12 cells. The block layout attempts to minimize bulk inductance while allowing enough space for the free passage of oil. The internal arrangement of the block is shown in Figure 4.

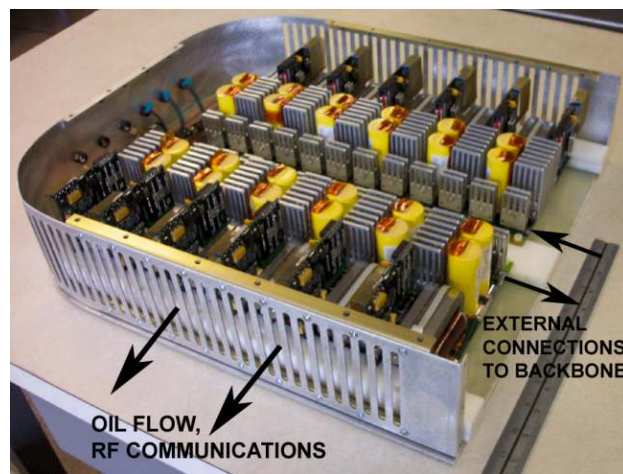

Figure 4: Block Assembly containing 12 Marx Cells.

The 12 Marx cells are arranged in two rows of six, with the free-wheeling diodes placed closest to the central plane. The FWDs have the shorter heatsinks, and the IGBTs use the larger ones between the capacitors. The control module of each cell faces towards the outside, allowing the 2.4GHz antenna an aperture through the vertical slots in the shielding.

Marx Cell Design

Each cell consists of an IGBT array, energy storage capacitor, free-wheeling diode, inductive isolator and a cell control module, arranged as shown in Figure 5.

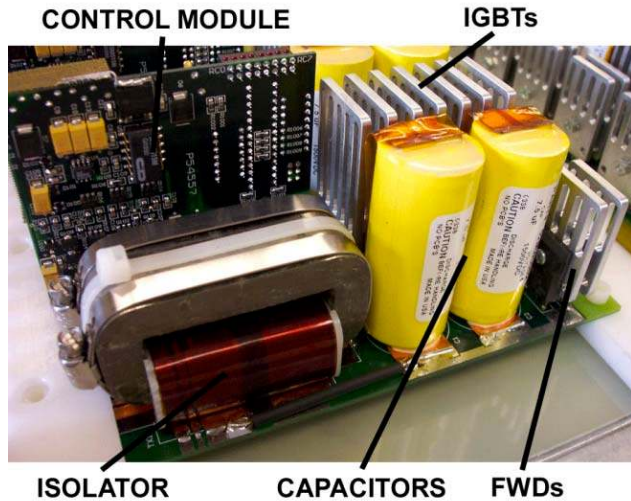

Figure 5: A Marx Cell.

All of the components including the inductive isolator are designed to surface-mount to the PCB to reduce cost. The cell control module mounts vertically to the main board, and contains the DC regulators, timing circuitry, PIC microcontroller and IGBT gate drivers.

Effects of capacitive surge currents

Stray capacitance in the klystron and the Marx bank itself will shunt a substantial amount of current to ground as the voltage rises. This surge current is in addition to the normal load current and must be supported by the IGBTs, energy storage capacitors and FWDs in each cell. Dynamic EM simulations of the stack predict peak IGBT surge currents of about 1000A, dropping to the nominal 550A within about 150ns. For the single-block test we added a 5000pF capacitive load in parallel to the 32ohm resistive load to simulate the 30-block capacitive load of 166pF. The measured surge current was about 850A x 200ns, owing to the current-limiting action of the IGBTs. No irregular circuit performance or overheating was observed in repetitive pulsed operation.

Waveform efficiency at 18kV, 550A output

It is important to shape the output voltage waveform so the klystron can use as much of the pulse energy as possible. Since the NLC klystrons are normally operated in the space-charge limited regime, the klystron beam current I_b is proportional to the beam voltage V_b to the 3/2 power. The instantaneous beam power is therefore proportional to $V_b^{5/2}$. The waveform efficiency is calculated by plotting the waveform of $V_b^{5/2}$, and placing the largest possible rectangle under the waveform with the required pulse width. The calculated efficiency is then simply the area of the rectangle divided by the total area under the $V_b^{5/2}$ waveform.

Figure 6 below shows the output voltage and current waveforms of a complete Marx block operating at 18kV and 550A, into a 32ohm resistive load. Figure 7 shows the calculated waveform efficiency based on the voltage waveform $V_b^{5/2}$. The $V_b^{5/2}$ waveform and the usable area are both multiplied by a constant of 6e-7 in order to plot them on the same graph as V_b for comparison.

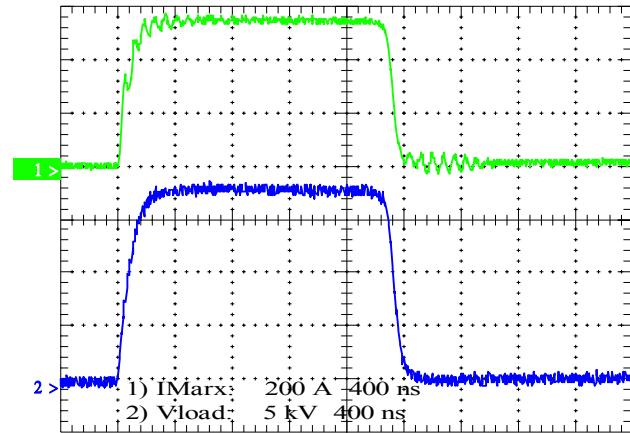

Figure 6: Output voltage and current waveforms.

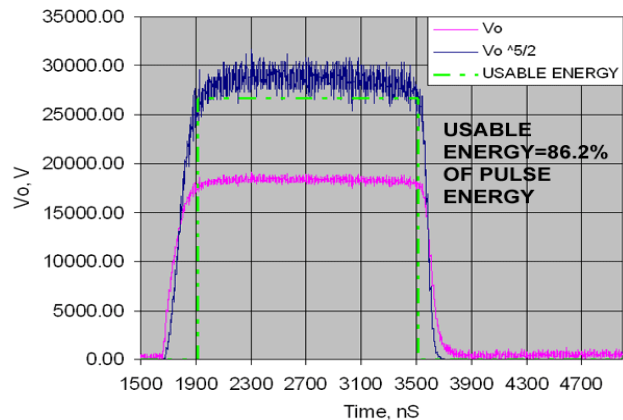

Figure 7: Waveform efficiency.

CONCLUSION

At this early stage there appears to be no fundamental limits preventing a solid-state Marx design from providing 500kV, 550A service to two klystrons with nominal load capacitance. Further test results will be presented in future papers.

REFERENCES

- [1] Anatoly Krasnykh SLAC, Box 4349 Stanford, CA 94309 "ANALYSES OF KLYSTRON MODULATOR APPROACHES FOR NLC" XX Intl Linac Conference, LINAC2000, Monterey, CA
- [2] A. Krasnykh, R. Akre, S. Gold, R. Koontz "A SOLID-STATE MARX-TYPE MODULATOR FOR DRIVING A TWT" 24th International Modulator Symposium, June 2000
- [3] R.J. Richter-Sand, R.J. Adler, R. Finch, B. Ashcraft "MARX-STACKED IGBT MODULATORS FOR HIGH VOLTAGE, HIGH POWER APPLICATIONS" North Star Research Corp, Albuquerque NM USA (505) 888-4908
- [4] Jeffrey A. Casey, Floyd O. Arntz, Marcel P.J. Gaudreau, Michael Kempkes Diversified Technologies, Inc. 35 Wiggins Ave. Bedford, MA USA "SOLID-STATE MARX BANK MODULATOR FOR THE NEXT LINEAR COLLIDER" 2003 Particle Accelerator Conference, May 12-16, Portland, Oregon