



City Research Online

City, University of London Institutional Repository

Citation: Kyriacou, P. A. (2005). Pulse oximetry in the oesophagus. *Physiological Measurement*, 27(1), doi: 10.1088/0967-3334/27/1/R01

This is the accepted version of the paper.

This version of the publication may differ from the final published version.

Permanent repository link: <https://openaccess.city.ac.uk/id/eprint/14690/>

Link to published version: <https://doi.org/10.1088/0967-3334/27/1/R01>

Copyright: City Research Online aims to make research outputs of City, University of London available to a wider audience. Copyright and Moral Rights remain with the author(s) and/or copyright holders. URLs from City Research Online may be freely distributed and linked to.

Reuse: Copies of full items can be used for personal research or study, educational, or not-for-profit purposes without prior permission or charge. Provided that the authors, title and full bibliographic details are credited, a hyperlink and/or URL is given for the original metadata page and the content is not changed in any way.

Pulse oximetry in the oesophagus

P A Kyriacou

School of Engineering and Mathematical Sciences, City University, London EC1V 0HB, UK

E-mail: PKyriacou@city.ac.uk

Abstract

Pulse oximetry has been one of the most significant technological advances in clinical monitoring in the last two decades. Pulse oximetry is a non-invasive photometric technique that provides information about the arterial blood oxygen saturation (SpO_2) and heart rate, and has widespread clinical applications. When peripheral perfusion is poor, as in states of hypovolaemia, hypothermia and vasoconstriction, oxygenation readings become unreliable or cease. The problem arises because conventional pulse oximetry sensors must be attached to the most peripheral parts of the body, such as finger, ear or toe, where pulsatile flow is most easily compromised. Since central blood flow may be preferentially preserved, this review explores a new alternative site, the oesophagus, for monitoring blood oxygen saturation by pulse oximetry. This review article presents the basic physics, technology and applications of pulse oximetry including photoplethysmography. The limitations of this technique are also discussed leading to the proposed development of the oesophageal pulse oximeter. In the majority, the report will be focused on the description of a new oesophageal photoplethysmographic/ SpO_2 probe, which was developed to investigate the suitability of the oesophagus as an alternative monitoring site for the continuous measurement of SpO_2 in cases of poor peripheral circulation. The article concludes with a review of reported clinical investigations of the oesophageal pulse oximeter.

Keywords: pulse oximetry, photoplethysmography, perfusion, oesophagus

1. Introduction

Pulse oximetry has been one of the most significant technological advances in clinical monitoring in the last two decades (Alexander *et al* 1989, Bowes *et al* 1989, Anonymous 2003, Tremper and Barker 1989, Welch 2005). Pulse oximetry is a non-invasive photometric technique that provides information about the arterial blood oxygen saturation (SpO_2) and

heart rate, and has widespread clinical applications. The use of pulse oximeters has been described in many settings: hospital, outpatient, domiciliary use and in veterinary clinics. In the early 1990s pulse oximetry became a mandated international standard for monitoring during anaesthesia following the publication in 1986 of the Harvard minimum standards for monitoring. Kelleher (1989) reviewed 220 references in an article published in 1989. In a follow-up review in 1992, Severinghaus and Kelleher (1992) found more than 500 new reports between 1989 and October 1991. Nearly 5000 further reports on pulse oximetry have been published since October 1991.

Although generally reliable, pulse oximeters do fail, in particular, in patients undergoing prolonged procedures such as cardiac, vascular, reconstructive or neuro-surgery, at just the time when the measurement of blood oxygen saturation would be clinically of most value (Ralston *et al* 1991, Reich *et al* 1996). Many of their limitations, both physiological and technical, will be discussed in this review. The hypothesis underlying this review is that a more central site, such as the oesophagus, will remain adequately perfused in the above-mentioned clinical situations, giving the possibility of monitoring SpO₂ at the oesophagus when conventional peripheral oximetry fails.

This review will first outline the basic physics, technology and applications of pulse oximetry including photoplethysmography. The limitations of this technique are also discussed leading to the proposed development of the oesophageal pulse oximeter. In the majority, the report will be focused on the description of a new oesophageal photoplethysmographic/SpO₂ probe, which was developed to investigate the suitability of the oesophagus as an alternative monitoring site for the continuous measurement of SpO₂ in cases of poor peripheral circulation. The technological developments of such a pulse oximeter and the results from clinical investigations will be presented.

2. Photoplethysmography and pulse oximetry

Photoplethysmography is a non-invasive optical technique widely used in the study and monitoring of the pulsations associated with changes in blood volume in a peripheral vascular bed (Roberts 1982, Dorlas and Nijboer 1985, Higgins and Fronek 1986, Lindberg and Oberg 1991). Whether the term 'plethysmography' is a misnomer is a matter of debate, yet the title has received general consent. Challoner (1979) made an excellent review of photoplethysmography. As discussed in Challoner's review, Hertzman in 1937 first coined the term plethysmograph. It was pointed out above that there is not total agreement that this is a strictly accurate name. An etymological definition would suggest that a plethysmograph records volume; thus, volumetric changes are recorded in the blood vessels of an organ. However, whether photoplethysmography measures only blood volume changes is open to question. The origin of the photoplethysmographic (PPG) signal has been the subject of continuing debate (Challoner 1979, Roberts 1982).

In photoplethysmography the emitted light, which is made to transverse the skin, is reflected, absorbed and scattered in the tissue and blood. The modulated light level which emerges, is measured using a suitable photodetector. It is possible for the hand or finger to be directly transilluminated where the light source, usually in the region of 800 nm to 960 nm, is on one side of the skin and the detector on the other side. This method, also called *transmission mode*, is limited to areas such as the finger, the ear lobe or the toe (Nijboer *et al* 1981, Mendelson and Ochs 1988). However, when light is directed down into the skin a proportion of this is backscattered so that it emerges from the skin adjacent to the light source. The light source and the photodetector can be positioned side by side. This method, also called the *reflection mode*, allows measurements on virtually any skin area (Nijboer *et al* 1981,

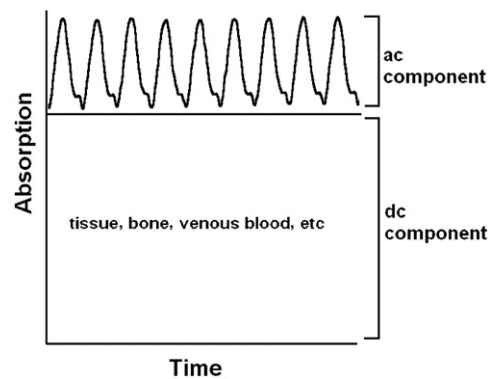

Figure 1. Photoplethysmographic (PPG) waveform as measured by transmission through tissue.

Mendelson and Ochs 1988). The intensity of the transmitted or reflected light which reaches the photodetector is measured and the variations in the photodetector current are assumed to be related to blood volume changes underneath the probe (Nijboer *et al* 1981, Roberts 1982). These variations are electronically amplified and recorded as a voltage signal called the photoplethysmograph. The photoplethysmographic signal (figure 1) is divided into two components:

- (i) A dc PPG component, a relatively constant voltage offset of which the magnitude is determined by the nature of the material through which the tissue passes (skin, cartilage, venous blood, etc).
- (ii) A pulsatile or ac PPG component synchronous with the heart rate is often assumed to be related to the arterial blood volume pulse. The ac PPG pulse shapes are indicative of vessel compliance and cardiac performance.

Pulse oximeters, as will be discussed in more detail in the following sections, estimate arterial blood oxygen saturation by shining light at two different wavelengths, red and infrared, through vascular tissue. In this method, the ac pulsatile PPG signal associated with cardiac contraction is assumed attributable solely to the arterial blood component. The amplitudes of the red and infrared ac PPG signals are sensitive to changes in arterial oxygen saturation because of differences in the light absorption of oxygenated and deoxygenated haemoglobin at these two wavelengths. From the ratios of these amplitudes, and the corresponding dc photoplethysmographic components, arterial blood oxygen saturation (SpO_2) is estimated. Hence, the technique of pulse oximetry relies on the presence of adequate peripheral arterial pulsations, which are detected as photoplethysmographic signals (Mendelson and Ochs 1988, Webster 1997).

3. Physics and technology of pulse oximetry

Theoretical descriptions of pulse oximetry often begin with a discussion of the Beer–Lambert law of light absorption (Webster 1997). It is beyond the scope of this review to describe in detail the Beer and Lambert approach, as it has been discussed and explained in detail in the literature (Webster 1997). It will be useful though to note that by itself this approach is incomplete, as it does not adequately account for the effects of a physical phenomenon called light scattering present within the tissue region under investigation. Biological tissue is a highly light-scattering medium and little information about its optical properties is available

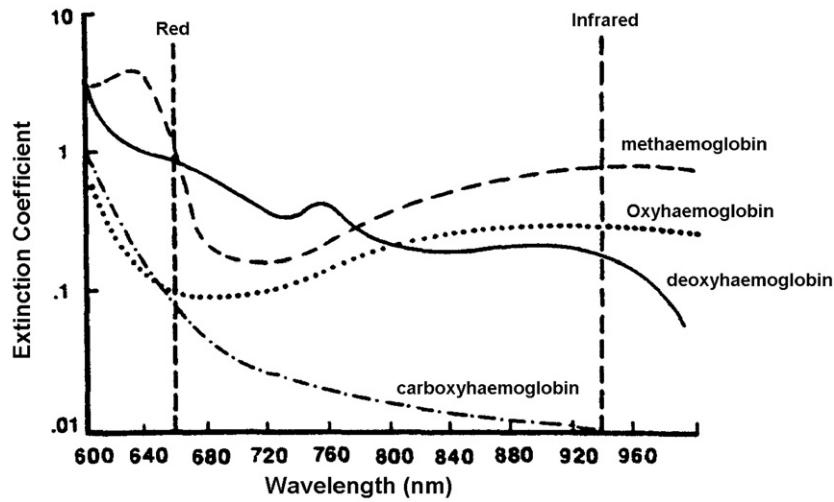

Figure 2. Extinction coefficients ($\text{Lmmol}^{-1} \text{cm}^{-1}$) of the four most common haemoglobin species; oxyhaemoglobin (HbO_2), deoxyhaemoglobin (Hb), carboxyhaemoglobin (COHb) and methemoglobin (MetHb) at the wavelengths of interest in pulse oximetry.

(Shimada *et al* 1984, Delpy 1988, Wray *et al* 1988, Schmitt 1991, Shvartsman and Fine 2003, Finlay and Foster 2004). In conventional practice, the effects of light scattering are accounted for by empirically calibrating the sensor and oximeter, and this appears to work well, but only up to a certain point (Fine and Weinreb 1995, Webster 1997). Assumptions inherently made during an empirical calibration are valid only for a limited range of saturations, and become invalid under extreme conditions. Nevertheless, the Beer–Lambert law approach helps to develop an understanding of the absorbance of light as it passes through living tissue and why and how pulse oximetry works.

3.1. Wavelengths for pulse oximetry

Pulse oximeters determine arterial blood oxygen saturation by measuring the light absorbance of tissue at two different wavelengths and using the arterial blood pulsation to differentiate between absorbance of arterial blood and other absorbers (skin, bone, venous blood). A good choice of wavelength is where there are large differences in the extinction coefficients of deoxyhaemoglobin and oxyhaemoglobin (Mannheimer *et al* 1997a) (figure 2). Another criterion for the wavelength selection is the relative flatness of the absorption spectra around the chosen wavelength (Moyle 1994, Mannheimer *et al* 1997b). The two conventional wavelengths used in pulse oximetry are 660 nm (red) and 940 nm (near infrared).

3.2. Calibration of commercial pulse oximeters

It could be considered that accurate values of SpO_2 can be obtained by application of simultaneous equations describing the Beer–Lambert law, but this is not the case, and most modern pulse oximeters apply the ‘red: infrared ratio’ (R) to a ‘look-up table’ (Moyle 1994).

$$R(\text{ratio}) = \frac{ac_{660}/dc_{660}}{ac_{940}/dc_{940}}. \quad (1)$$

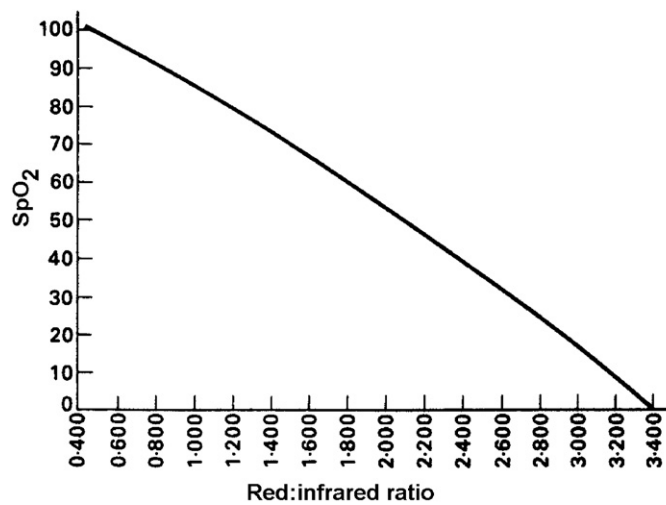

Figure 3. Empirical relationship between arterial saturation and 'red:infrared' ratio (R).

The manufacturers calibrate pulse oximeters empirically by correlating the measured ratio (R) of ac/dc signals from the red and infrared photoplethysmographs obtained from a large group of healthy volunteers with arterial oxygen saturation (SaO_2) values generally greater than 70%. Blood SaO_2 values are obtained directly from a standard *in vitro* CO-oximeter. This calibration procedure involves desaturating the subjects by asking them to breathe hypoxic gas mixtures and collecting optical measurements of blood samples at different steady-state oxygenation levels. Consequently, different brands of pulse oximeters may display slightly different values, depending on the internal calibration of the oximeter. A typical relationship between the ratio (R) and SpO_2 is shown in figure 3.

One of the limitations of this traditional calibration method is the limited range of oxygen saturation that can be acquired. Ethical issues prevent intentional desaturation of healthy subjects below a certain point due to the risk of hypoxic brain damage.

3.3. Technical developments of commercial pulse oximeters

A typical commercial pulse oximeter consists of an opto-electronic probe that operates either in reflectance or in transmittance mode and a microprocessor-controlled electronic system (figure 4). The technology of pulse oximetry and the advancements in signal processing for eliminating motion artefact or dealing with low amplitude PPGs is well reviewed (Polge 1987, Wukitsch *et al* 1988, Severinghaus 1993, Webster 1997, Goldman *et al* 2000). This section describes briefly the main blocks comprising the pulse oximeter system, such as the analogue and digital processing, the microprocessor and the front display (figure 4).

The pulse oximeter probe has a single photodetector receiving signals from the infrared (IR) and red (R) emitters. The currents through the emitters are controlled by the emitter driver, which comprises a pair of current sources (R and IR) and a multiplexer. Emitter drive currents may vary between 40 mA and 120 mA. The multiplexer turns the red and infrared emitters on and off at a rate of approximately 325 Hz in sequence (but varies with different manufacturers) (Webster 1997). The multiplexed PPG signals from the photodetector are received by a transimpedance amplifier that converts the current output into a signal voltage. The mixed PPG signals are separated into red and infrared with the use of a demultiplexer. The signals are then

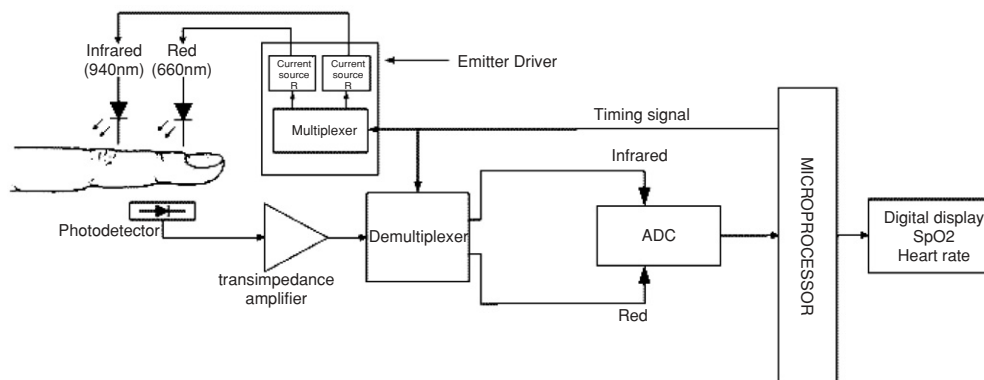

Figure 4. Basic block diagram of a commercial transmission mode pulse oximeter.

converted by an analogue-to-digital converter (ADC) into a form suitable for manipulation by the microprocessor. The digitized information is processed by the microprocessor to compute the blood oxygen saturation from the ratio (R) derived from the signal at the red wavelength compared with the signal at the infrared wavelength. Pulse oximeters usually display blood oxygen saturation (SpO_2) in per cent together with heart rate, and photoplethysmograph.

4. Pulse oximeter probes and their applications

4.1. Pulse oximetry probes

The probe of the original pulse oximeter as described by Yoshiya *et al* (1980) was based on a bulky fibre optic cable. The fibre optic cable in this implementation was used only as a guide to conduct light from a quartz halogen lamp to the remote measurement side and to conduct the light transmitted through the tissue back to the photodetector. The light source and the photodetector were both housed inside the oximeter. Narrow-bandpass interference optical filters were used in combination with a mechanical chopper to select properly the red and infrared wavelengths (Mendelson 1992). An improved design of a non-invasive pulse oximeter probe was introduced in the United States in the early 1980s (figure 5).

This much simpler design, which dominates most of the commercial pulse oximeters nowadays, consists of a pair of small red and infrared emitters and a single highly sensitive silicon photodetector mounted inside either a reusable spring loaded clip (figure 5), or a disposable adhesive wrap (Mendelson 1992). A flexible cable connecting the probe and the pulse oximeter unit carries electric power to the emitters and the signal from the photodetector. A synopsis of different types of pulse oximetry probes used today in the clinical setting is presented below.

4.1.1. MRI probes. When a pulse oximeter is used during magnetic resonance imaging (MRI), the very high magnetic field strengths involved with this imaging modality may give erroneous readings or no readings at all (Wahr *et al* 1995). To overcome the problem manufacturers have produced pulse oximeters where all of the electronic and optical components are in the housing of the main unit. The light energy is directed to and from the patient by optical fibres. The complete pulse oximeter is kept beyond the influence of the magnetic field (approximately 3 m) of the MRI scanner (Webster 1997).



Figure 5. Typical reusable spring loaded clip pulse oximetry probe.

4.1.2. Foetal probes. This is an area of continued research since no probe yet is used in routine foetal monitoring (Dildy *et al* 1994, Dildy 2004). Several designs of foetal pulse oximetry probes have been developed over the last few years. The probes are guided into the cervix and must be placed beyond the presenting part and the transcervical region (just beyond the cervix). The probe is placed on the temple of the foetus and therefore has less interference from hair (Webster 1997).

4.1.3. Reusable probes. Generally, all probes with nonadhesive or disposable adhesive sensors are reusable probes. The main advantage of reusable pulse oximetry probes is the low use cost involved. However, reusable probes require cleaning between patients to minimize the risk of cross contamination (Kelleher 1989).

4.1.4. Disposable probes. In the past few years, many pulse oximeter manufacturers have produced disposable probes. One of the advantages of disposable probes is the elimination of any form of cross contamination between patients since disposable probes are used on a single patient.

4.2. Applications of pulse oximetry

Pulse oximeters, as has been discussed above, are non-invasive, easy to use and readily available. Due to these characteristics, they have an abundance of clinical applications. This may be seen as an overstatement, but as more and more pulse oximeters are coming in use, more and more hypoxaemic events are being seen as precursors of pathological events. Some of the main areas in which they are used are anaesthesia, patient transport, childbirth, neonatal and paediatric care, dentistry and oral surgery, sleep studies and many other applications. Some of them are described briefly.

4.2.1. Anaesthesia. The pulse oximeter is most often and most importantly used when anaesthesia is given. Several studies have shown that desaturation is often a problem

during induction of anaesthesia (Drummond and Park 1984). This is the most critical time of general anaesthetic because of the side effects of the induction agents, onset of neuromuscular blockade, loss of protective reflexes, mechanical problems with the airway, respiratory depression and problems with tracheal intubation.

4.2.2. Emergency medicine. Anaesthetists were quick to see the enormous benefit to the safety of the patient of using pulse oximeters, and doctors, nurses and medical technicians involved in emergency care soon recognized the advantage of pulse oximetry (Lambert and Crinnion 1989). A retrospective study by Anderson *et al* (1988) showed that failure to recognize hypoxaemia has been identified as one of the major avoidable causes of death in trauma patients. Pulse oximeters are now regularly used in accident and emergency departments and in the pre-hospital care of the sick and injured.

4.2.3. Postoperative recovery. The period between the end of surgery and when the patient is fully conscious is often when hypoxaemia is most likely to go unnoticed. The greatest risk during this period is respiratory failure. For these reasons the pulse oximeter must be used regularly in the postoperative recovery phase (Tyler *et al* 1985, Pullerits *et al* 1987, Kelleher 1989, Moyle 1994).

4.2.4. Childbirth. The process of labour and delivery is a stressful time for both the mother and the foetus. If the foetus does not have sufficient metabolic reserve to withstand this ordeal, it is at risk of hypoxia and of sustaining subsequent brain damage (Minnich *et al* 1990). Many difficulties have been encountered when attempting to monitor foetal pulse oximetry. The obvious problem is that the foetus is not accessible. The potential application of pulse oximetry to foetal monitoring during labour has been demonstrated by several groups (Gardosi *et al* 1991, Klauser *et al* 2005).

4.2.5. Neonatal and paediatric care. Low and high arterial oxygen levels can both be damaging to newborn infants. Infants who are hypoxic may develop organ damage, and hypoxia may also cause pulmonary hypertension (Moyle 1996). The great concern of neonatal paediatricians is to prevent retinopathy of prematurity, which is caused by high levels of retinal oxygenation and may lead to blindness (Moyle 1994). It is, therefore, essential to monitor accurately the oxygen levels of sick and premature newborn infants.

4.2.6. Dentistry and oral surgery. Many papers have recommended the use of pulse oximetry during general anaesthesia for dental procedures, pointing out that pulse oximeters should be applied to all patients even for short procedures (Hovagim *et al* 1989).

4.2.7. Sleep studies and exercise. Many people become desaturated during sleep or heavy exercise. The cause of desaturation during sleep is due to a disorder known as sleep apnoea (Webster 1997). Desaturation can occur during heavy exercise due to poor ventilation or chronic obstructive pulmonary disease (COPD). The use of pulse oximetry during sleep and exercise aids in the diagnosis of these respiratory problems (Trang *et al* 2004).

4.3. Future applications of pulse oximetry

Although pulse oximetry seems to be at the peak of its development, there is always room for further improvement and optimization. Many of these improvements relate to specific

applications. Improvements, which will increase the performance of pulse oximetry during transport, are to lengthen the battery life in portable units. Reducing the occurrence of false alarms would be beneficial in all applications, but especially during long-term monitoring when staff cannot always be in the room. The application of foetal pulse oximetry is an exciting on-going research by many groups (Dildy 2001, Reuss 2004). In this unique application, sensor attachment to the foetal scalp must be improved. Other potential applications of pulse oximetry have been suggested for monitoring oxygen saturation via the retinal fundus in the eye (De Kock *et al* 1993, Nelson *et al* 2005). The direct application of pulse oximetry to an organ, such as the liver, the kidney, the gut or the colon, will be a very useful application in determining organ SpO₂, regardless if the patients SpO₂ as measured from an extremity (finger) is normal (Denobile *et al* 1990, Yilmaz *et al* 1999, Crerar-Gilbert *et al* 2002).

5. Limitations of pulse oximeters

5.1. Calibration assumptions

Initially, the conversion from absorbancy ratios to arterial oxygen saturation as described in previous sections is based on experimentally derived calibration curves (figure 3). These curves are based on measurements in healthy young volunteers after induction of hypoxaemia (Moyle 1994, Sinex 1999). An unavoidable limitation is that pulse oximeters can only be as accurate as their empirical calibration curves. Understandably, researchers were limited in the degree of haemoxaemia inducible in these volunteers, to a SaO₂ of approximately 75% to 80%. Therefore the shape of the curve (figure 3) below these levels (75% to 85%) must be extrapolated, with obvious implications for the accuracy of pulse oximetry at low saturation levels. Studies showed such great inaccuracy and bias at low oxygen saturation that manufacturers revised early calibration curves and software (Severinghaus and Naifeh 1987). More studies, however, continued to show significant bias, increasing as oxygen saturation decreases, although it has been justifiably pointed out that few, if any, clinical treatment decisions will hinge on whether the oxygen saturation is actually 50% or 60% (Kelleher 1989).

5.2. Dyshaemoglobinaemias

Many substances in the blood can interfere optically with pulse oximetry. This interference generally takes the form of false absorbers, or components besides deoxyhaemoglobin or oxyhaemoglobin that will absorb light within the red and near-infrared wavelengths used in pulse oximetry. The most significant potential false absorbers in the circulation are carboxyhaemoglobin (*COHb*) and methaemoglobin (*MetHb*) (Kelleher 1989, Richardson 2005). Being two-wavelength devices, pulse oximeters can only deal with two haemoglobin species (deoxyhaemoglobin and oxyhaemoglobin). Therefore, both *COHb* and *MetHb* will cause errors in the pulse oximeter readings (Barker and Tremper 1987, Barker *et al* 1989). When the presence of these Hb species is suspected, pulse oximetry should be supplemented by *in vitro* multiwavelength CO-oximetry.

5.3. Intravenous dyes

Intravenous dyes are known to have potentially profound effects on pulse oximetry readings, resulting in falsely low measured oxygen saturations. Methylene blue, with very high absorbance at 660 nm, causes spurious decrease in SpO₂ (Kessler *et al* 1986, Scheller *et al* 1986, Sidi *et al* 1987).

5.4. Anaemia

Anaemia appears to adversely affect the accuracy of pulse oximetry, although the mechanism is unclear, and it may do so only in the presence of hypoxia. In theory, anaemia should not affect pulse oximetry at all, as the ratio of relative absorbances should be preserved and unchanged by changes in total haemoglobin concentration within the sample (Severinghaus and Koh 1990). A study of non-hypoxic human patients with acute anaemia showed good accuracy with pulse oximetry (Jay *et al* 1994).

5.5. Skin pigmentation and nail polish

Skin pigmentation has shown variable effects on pulse oximetry (Volgyesi and Spahr-Schopfer 1991, Bickler *et al* 2005). Primarily, dark pigmentation appears to make adequate light penetration more difficult, with significantly more signal detection failures. More concerning are some studies of pigmentation effects which have shown overestimation of oxygen saturation, both in models and in human subjects (Ries *et al* 1989). Similarly, there is evidence for the effects of nail polish on pulse oximetry, but little consensus on occurrence or degree (Kataria and Lampkins 1986, Cote *et al* 1988, Chan *et al* 2003).

5.6. Electromagnetic interference

Electromagnetic interference (EMI) can affect the accuracy of pulse oximeters and other medical devices. It may be generated by many sources, mostly man made but it may also result from atmospheric events.

5.7. Interference due to electrocautery

Electrocautery can interfere with pulse oximetry by artifactually decreasing SpO₂ readings, or by setting off false alarms (Wahr *et al* 1995). The cause is the wide spectrum of radio frequency emissions picked up directly by the photodetector in the pulse oximeter probe (Block and Detko 1986). New signal extraction technology (*MASIMO*) claims to be more accurate in the presence of electrocautery (Wahr *et al* 1995).

5.8. Signal artefact

Most commonly, problems in pulse oximetry arise from signal artefact. Signal artefact results from false sources of signal or from a low signal-to-noise ratio. False signal can arise from detection of non-transmitted light (ambient sources or optical shunt) or from non-arterial sources of alternating signal. A low signal-to-noise ratio results from inadequate signal complicated by an excess of physiological or technical noise. The oximetry system as outlined in the previous sections assumes that the sum of the light absorbed and the light transmitted is equal to the incident light, with no other light loss or gain affecting the detector. Ambient light, however, is potentially a major source of interference (Fluck *et al* 2003). Recognizing this, designers of pulse oximeters divided the emitter and detector activities into three sensing periods, cycling at hundreds of times per second. Two of these periods use light emitted by the emitters at each of the two incident wavelengths. In the third period neither emitter is activated and the photodiode detector measures only ambient light, the influence of which is subsequently eliminated from the emitter-illuminated sensing periods. However, cases of ambient light interference still occur (Hanowell *et al* 1987). Implicated sources include fluorescent lighting, surgical lamps, fiber optic instruments and sunlight. Covering

the probe with an opaque shield offers a simple solution. Optical shunting occurs when light from the emitters reaches the photodetector without passing through an arterial bed. This occurs most commonly with inappropriate probe selection, as when a digit probe is placed on the ear lobe, or with probe misplacement (Barker *et al* 1993, Webster 1997). In both ambient light interference and optical shunt, the result is the addition of false signal to both wavelengths emitted (Kelleher and Ruff 1989). Non-arterial sources of alternating signal most commonly result from motion artefact. Motion artefacts, such as during shivering, seizure activity or exercise, are usually recognized by false or erratic heart rate displays or by distorted photoplethysmographic waveforms (Severinghaus and Kelleher 1992, Hanning and Alexander-Williams 1995). When interference does occur from motion artefact it again tends to be additive into both the red and infrared wavelength channels (Pologe 1987), with a resultant absorbance ratio (R) becoming nearer to 1 and an SpO₂ approaching 85% (see figure 3).

Although different oximeter models employ different data processing, the saturation values acquired per second are typically averaged over a period of 2–16 s before a reading is given, serving in part to limit the impact of motion artefact (Kidd and Vickers 1989). Newly developed signal processing algorithms by MASIMO technologies have demonstrated successfully that can minimize or eliminate erroneous estimation of SpO₂ due to movement artefact (Goldman *et al* 2000).

5.9. Inadequate pulsatile signals

Apart from the physiological and technical limitations of pulse oximeters described in this review, they have also been reported to fail in patients with compromised peripheral perfusion (Severinghaus and Spellman 1990, Freund *et al* 1991, Moller *et al* 1993, Reich *et al* 1996). Pulse oximetry is a pulse-dependent technique, and any significant reduction in the amplitude of the pulsatile component of the photoplethysmographic signal can lead to dubious values for blood oxygen saturation (SpO₂) or complete failure. Hence, pulse oximeters require adequate peripheral perfusion to operate accurately. When peripheral perfusion is poor, as in states of hypovolaemia, hypothermia and vasoconstriction, oxygenation readings become unreliable or cease (Palve and Vuori 1989, Palve 1992a, 1992b). Such clinical situations occur, for example, after prolonged operations, especially hypothermic cardiopulmonary bypass surgery. The problem arises because conventional pulse oximetry sensors must be attached to the most peripheral parts of the body, such as finger, ear or toe, where pulsatile flow is most easily compromised. Measurements at sites other than the finger or ear, such as the forehead and nose, give no improvement in poorly perfused patients (Rosenberg and Pedersen 1990, Clayton *et al* 1991). Thus, SpO₂ readings are often unobtainable at just the time when they would be most valuable.

Therefore, the question becomes what to do in such cases, particularly those in which the oximeter is unable to find an adequate pulse at any of the available peripheral sites. There is, therefore, a need to find a means of solving this frustrating and serious clinical problem.

6. Oesophageal pulse oximetry

In an attempt to overcome the difficulties associated with conventional measurements of arterial blood oxygen saturation during conditions of poor peripheral perfusion and pulsation, the oesophagus has been proposed as a potential measurement site on the hypothesis that

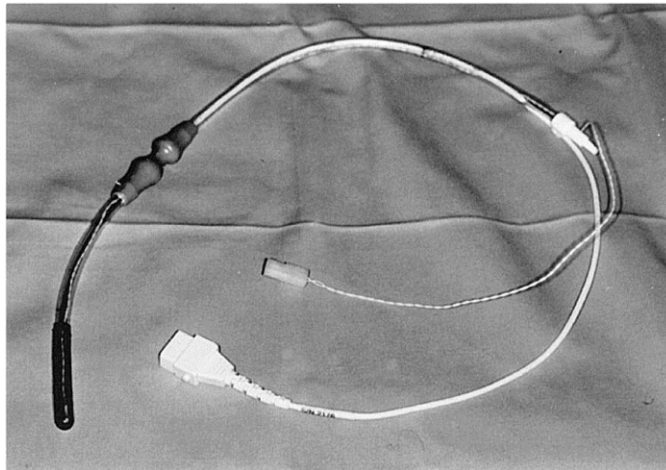

Figure 6. The reflectance transoesophageal probe (oesophageal probe is an 18-gauge stethoscope with a temperature sensor at the distal tip and an oximetry sensor approximately 7 cm proximally).

perfusion may be better preserved at this central site. The oesophagus is perfused directly by main arteries. The cervical oesophagus is supplied mainly by branches of the inferior thyroid artery. The chief blood supply of the thoracic oesophagus is either by branches of the bronchial arteries, or direct from the aorta, and there are branches of the left gastric and inferior phrenic arteries running along the surface of the lower oesophagus for 2–3 cm above the diaphragm (Romanes 1972, Marieb 1992).

Atlee and Bratanow (1995) proposed to use the upper oesophagus as a measurement site. They presented results of blood oxygen saturation measurements obtained at the cricopharyngeus muscle in the upper oesophagus (14 ± 1 cm from incisors) using a reflectance ‘transoesophageal’ probe where the optical components of the oximetry sensor were incorporated into a traditional anaesthesia oesophageal stethoscope (figure 6). Technical details of the probe or processing system are not available in the literature.

Clinical studies using the ‘transoesophageal’ probe compared SpO_2 measurements with simultaneous SpO_2 measurements from conventional pulse oximetry probes (Nellcor N-200; N-200F) and arterial oxygen saturation (SaO_2) measurements using an *in vitro* CO-oximeter in 16 anaesthetized adult patients. The results showed that the ‘transoesophageal’ probe underestimated or overestimated SpO_2 values depending on the geometry of the sensor (Prielipp *et al* 1996, Borum 1997). Another limitation of this design was the difficulty in placing the probe accurately at the cricopharyngeus muscle, as the procedure required considerable expertise. It was also found that electrocautery interference resulted in more frequent signal dropout and delayed signal reacquisition than for a peripheral pulse oximetry probe. The successful use of the ‘transoesophageal’ pulse oximeter has been demonstrated in a single patient study in which peripheral oximetry was unobtainable (Borum 1997). A more recent study (Prielipp *et al* 2000) used the upper oesophageal pulse oximeter in a group of ten patients undergoing coronary bypass surgery and compared their results with two commercial finger pulse oximeters (Criticare 504-US and Nellcor N-200). The study, however, could not confirm that the upper oesophageal pulse oximeter was superior to conventional peripheral pulse oximeters. Vicenzi *et al* (2000) used the same probe on a study of 40 severely traumatized or diseased intensive care patients. They compared SpO_2 values from the upper oesophagus with those from a finger pulse oximeter (Hewlett-Packard). The

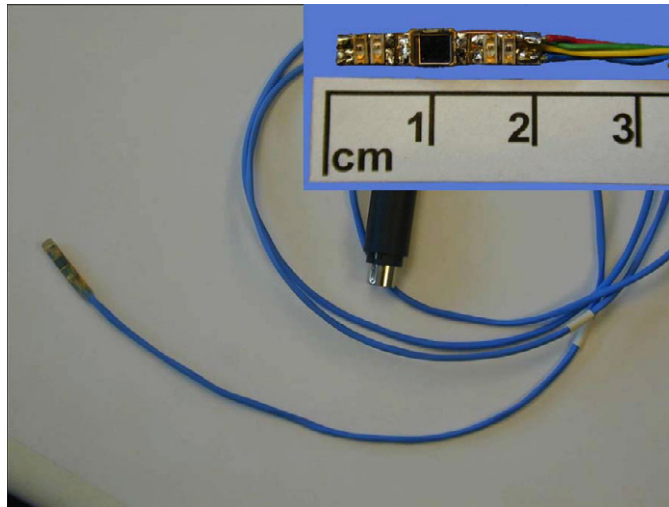

Figure 7. Reflectance oesophageal pulse oximetry probe.

authors concluded that assuming correct positioning of the ‘transoesophageal’ probe, readings from the upper oesophagus were more consistent with SpO₂ values from the finger pulse oximeter.

All the studies using the ‘transoesophageal’ probe did not present any investigations into the morphology or the quality of PPG signals at the cricopharyngeus muscle or at any other depths within the oesophagus.

To overcome the drawbacks of the upper oesophageal pulse oximeter, and the difficulties which are associated with attempts to measure arterial blood oxygen saturation in the poorly perfused peripheral circulation, Kyriacou (2001) describes a new oesophageal pulse oximetry system. This new system comprised a miniaturized oesophageal pulse oximeter probe and a custom made processing unit which allows the detailed investigation of photoplethysmographic signals and SpO₂ values within the whole depth of the oesophagus in healthy and critically ill patients, and this will be the subject of the following sections.

7. Technical developments of the oesophageal pulse oximeter

7.1. Oesophageal pulse oximeter probe

A new reflectance oesophageal pulse oximeter probe was constructed (Kyriacou *et al* 1999, 2002c). This new probe comprised two infrared and two red surface mount emitters and a surface mount photodetector (figure 7). The peak emission wavelengths of the infrared and red emitters used were 880 nm and 655 nm, respectively. The oesophageal probe with attached cable was designed to fit into a plastic transparent disposable stomach/oesophageal tube (Pennine Healthcare, Derby, UK). The oesophageal tube used was a size 20 French gauge (external diameter: 6.66 mm, internal diameter: 4.66 mm, length: 780 mm, without x-ray detectable line) mainly used for gastric lavage (washout) or other gastric surgical procedures. A finger reflectance probe, optically and electronically identical to the oesophageal probe has also been developed to facilitate comparisons between the two sites (oesophagus and finger) (Kyriacou *et al* 2002c).

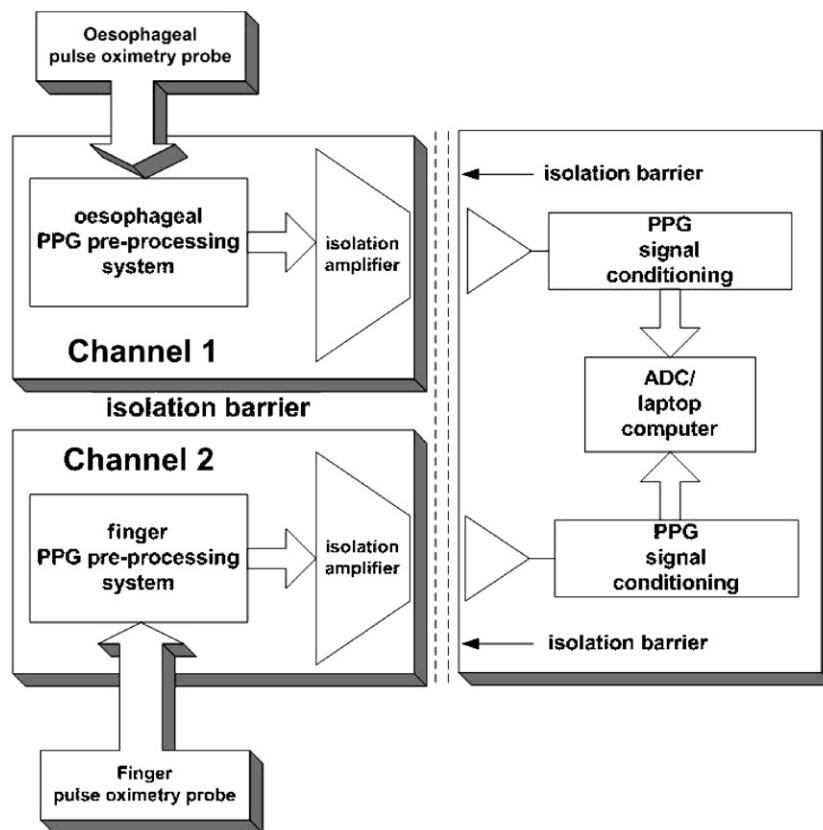

Figure 8. Main block diagram of the oesophageal processing system including the identical finger channel.

7.2. Oesophageal processing system: hardware

A processing system was constructed to pre-process, record and display oesophageal and finger PPG signals and estimate SpO_2 values on a laptop personal computer (figure 8). Both channels were identical and only the oesophageal will be described.

7.2.1. Pre-isolation circuitry of the processing system. The master clock and timing generator circuit (figure 9) of the processing system was used to generate the timing signals for switching (ON/OFF) the red (R) and infrared (IR) emitters. These timing control signals were also used for synchronizing the demultiplexer that separated the mixed (red and infrared) PPG signals at the output of the current-to-voltage ($I-V$) amplifier circuit into red and infrared PPG signals. The emitters were driven by a pair of identical constant current sources one for each wavelength. Analogue switches were used to time multiplex the red and infrared emitters at 75 Hz (Kyriacou 2001, Kyriacou *et al* 2002c).

The mixed PPG signal from the output of the $I-V$ amplifier was demultiplexed to separate the PPG signals into two independent channels (red and infrared). Low-pass filters were used to eliminate the high frequency switching noise from the demultiplexer. The red and infrared PPG signals were then passed through the isolation barrier of the analogue isolation amplifier to the post-isolation circuitry of the processing system.

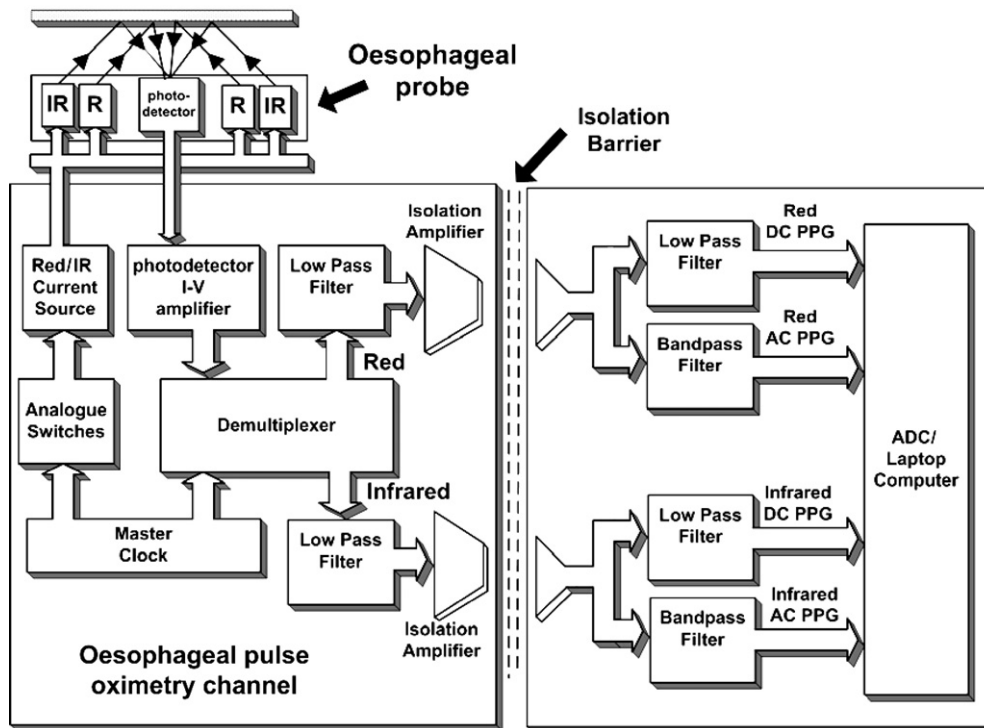

Figure 9. Oesophageal pulse oximeter processing system.

7.2.2. *Post-isolation circuitry of the processing system.* Two analogue isolation amplifiers were used (figure 9). The infrared and red PPG signals were split into independent channels (infrared ac and dc and red ac and dc) using active filters (Kyriacou 2001, Kyriacou *et al* 2002c).

7.3. *Oesophageal processing system: software*

All PPG output signals were digitized (100 samples per second) by a 16-bit data acquisition card on a laptop personal computer. The digitized PPG signals were analysed by a Virtual Instrument (VI) implemented in LabVIEW (National Instruments Corporation, Austin, TX). This VI read the oesophageal and finger PPG data, converted them into a spreadsheet format and saved them into a file specified by the user and displayed the signals in real time on the screen of the laptop computer (Kyriacou 2001, Kyriacou *et al* 2002c). Algorithms were also developed in the VI for the online estimation of oesophageal SpO_2 . The algorithm used to estimate oesophageal SpO_2 calculated the ratio (R) (see equation (1)) of the quotients of the ac and dc PPG amplitudes at the red (655 nm) and infrared (880 nm) wavelengths. The ratio (R) was then used to compute the arterial oxygen saturation (SpO_2) using the equation

$$SpO_2 = 110 - 25R. \quad (2)$$

This equation is a linear approximation to an empirical calibration curve established by measurements on a large group of healthy volunteers with arterial blood oxygen saturation (SaO_2) values generally greater than 70% (Webster 1997). Figure 10 depicts a typical VI screen of the developed oesophageal pulse oximeter processing system incorporating a finger and an ECG channel.

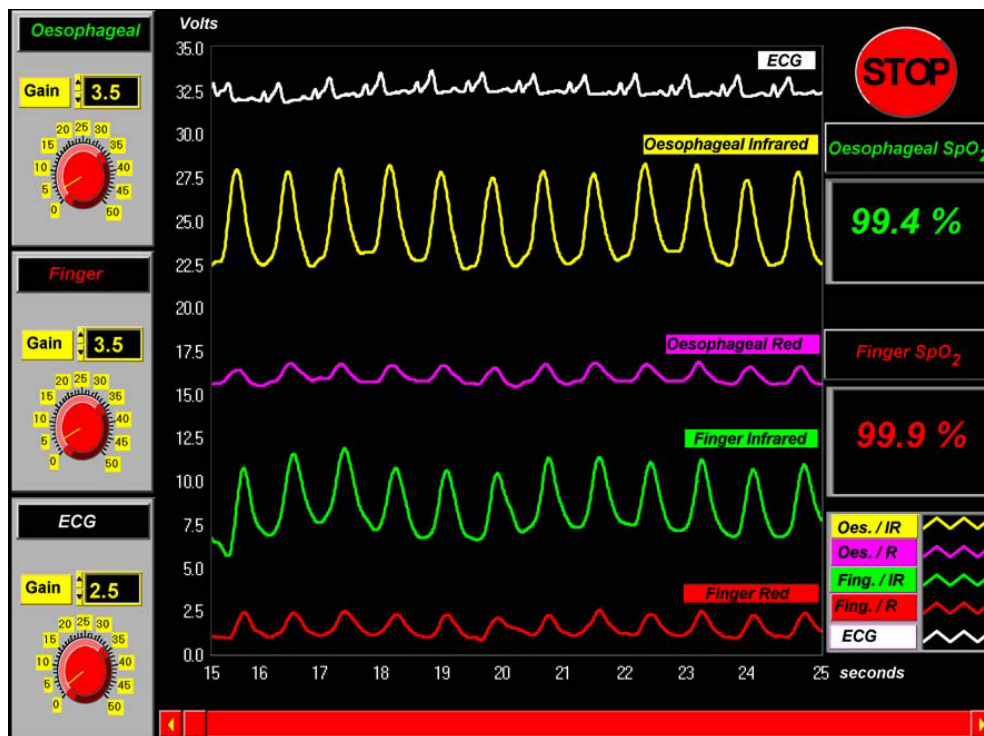

Figure 10. Virtual instrument (VI) screen of the oesophageal pulse oximetry system.

The following sections will describe the various clinical investigations performed using the above-described oesophageal pulse oximeter to investigate for the first time PPG signals and SpO₂ values from the whole length of the oesophagus from healthy and critically ill patients.

8. Clinical investigation 1: comparison of oesophageal and finger PPGs in healthy anaesthetized patients

8.1. Clinical method

Twenty consented healthy (ASA 1 or 2) adult patients who were to undergo tracheal intubation as a routine part of general anaesthesia were studied (Kyriacou *et al* 1999, Kyriacou 2001). Following induction of general anaesthesia the oesophageal probe was advanced under direct vision into the oesophagus until the end of the probe was between 25 cm and 30 cm from the upper incisors (figure 11). The identical reflectance finger probe was also placed on the index finger of the patient.

8.2. Results

Figure 12 shows typical red and infrared ac PPG traces obtained from the middle third of the oesophagus and the finger of an anaesthetized patient with the mechanical ventilator temporarily switched off (Kyriacou *et al* 1999). When the ventilator was switched on, the

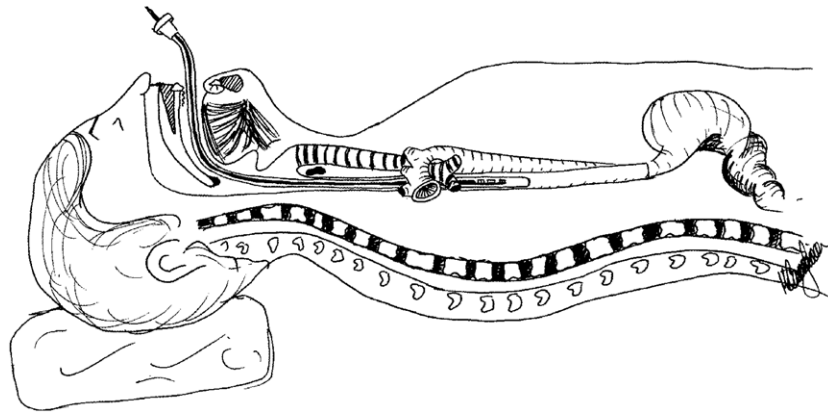

Figure 11. The oesophageal PPG probe contained within the stomach tube is seen placed in the oesophagus via the mouth.

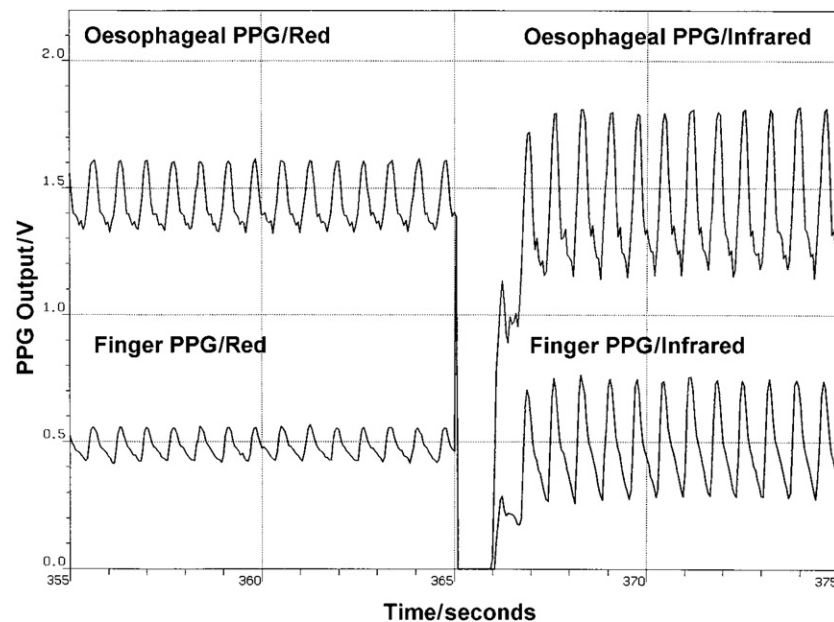

Figure 12. Typical PPG traces for the red and infrared wavelengths from the middle third of the oesophagus and the finger of an anaesthetized patient with the mechanical ventilator temporarily switched off.

oesophageal PPG traces were modulated by an artefact synchronous with the approximately 5 s period of the ventilator, as shown in figure 13.

Figure 14 shows the means, standard deviations (SD) of the peak-to-peak amplitudes of the red and infrared ac PPGs from the oesophagus and the finger of the 20 patients studied (Kyriacou *et al* 1999).

Statistically significant differences were found between the PPG amplitudes in the mid-oesophagus and the PPG amplitudes at the finger at the infrared wavelength. There were

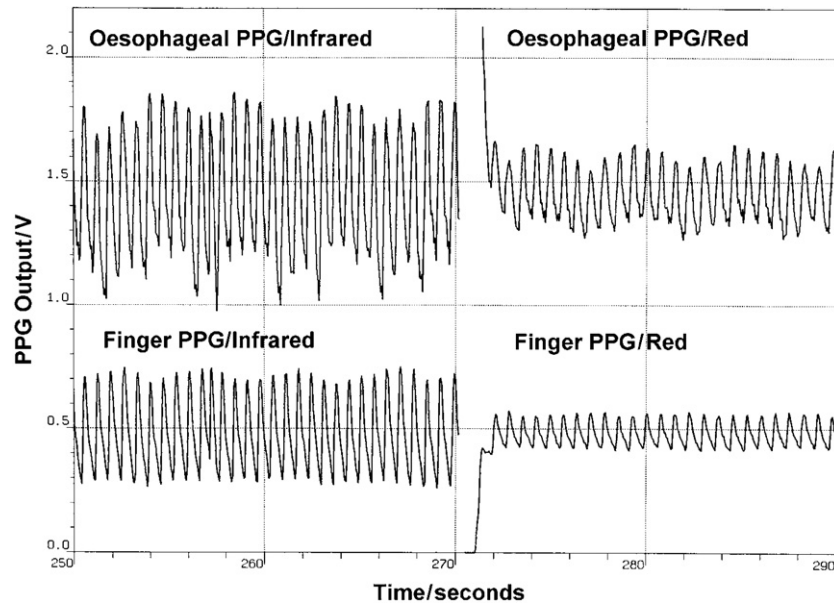

Figure 13. PPG traces for the red and infrared wavelengths from the middle third of the oesophagus and the finger of an anaesthetized patient with the mechanical ventilator switched on.

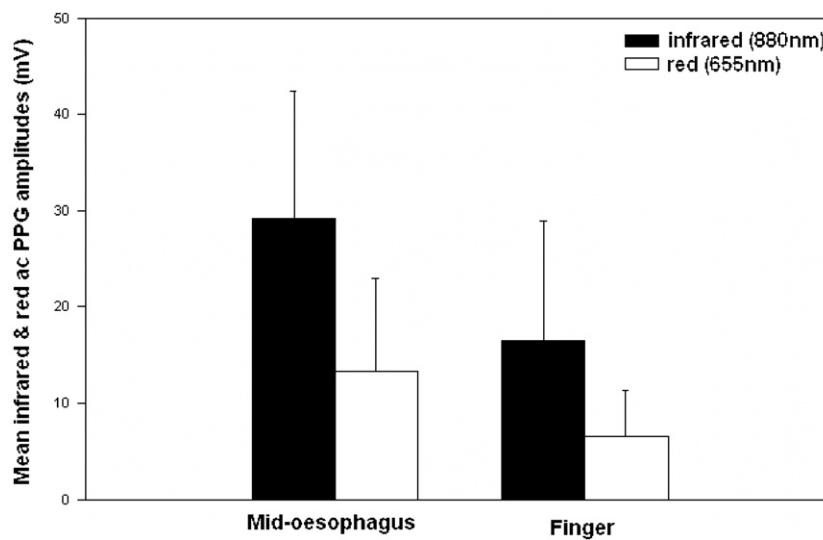

Figure 14. Mean peak-to-peak PPG signals (\pm SD) at red and infrared wavelengths from the mid-third of the oesophagus and the finger.

no significant differences between the PPG amplitudes in the mid-oesophagus and the PPG amplitudes at the finger at the red wavelength. The amplitudes of the oesophageal PPGs were on average approximately three times larger than those obtained simultaneously from a finger for both wavelengths.

9. Clinical investigation 2: 'PPG mapping of the oesophagus'

9.1. Clinical method

A new clinical study was performed by Kyriacou *et al* (2001) to investigate in more detail the quality of PPG signals within the whole length of the oesophagus. The preliminary objective of this study was to characterize PPGs in healthy (ASA 1) anaesthetized patients undergoing low risk surgery and to determine whether there would be sufficient PPG amplitudes at red and infrared wavelengths throughout the oesophagus to make pulse oximetry feasible.

Thirteen adult elective surgery patients were recruited for this study. In this group of patients, the oesophageal probe was advanced into the oesophagus until the end of the probe was 35 cm from the upper incisors. PPG traces from the oesophagus at both wavelengths were recorded for approximately 5 min at this depth. Measurements were repeated at 30, 25, 20 and 15 cm from the upper incisors (Kyriacou *et al* 2001).

9.2. Results

Measurable ac PPG traces at both wavelengths were obtained in the oesophagus at all five depths in all patients. Figure 15 depicts typical traces from one patient for the five depths.

Figure 16 gives the mean \pm SE of the ac PPG amplitudes at both wavelengths at the five oesophageal depths for the 13 patients. The ac PPGs in the mid to lower oesophagus (depths of 20 cm or greater) have significantly larger mean amplitudes at both wavelengths than those in the upper oesophagus (15 cm). The maximum mean oesophageal amplitude for each wavelength occurs at the depth of 25 cm. The mean value of the ac PPG amplitude at 25 cm is a factor 4.8 higher than that at 15 cm at the infrared wavelength and a factor of 6.7 higher at the red wavelength.

Statistically significant differences between the PPG amplitudes in the upper oesophagus (15 cm) and the amplitudes at all other depths at the infrared wavelength were found. This was also true for the red wavelength except that there is no significant difference between the amplitudes at the depths of 15 cm and 35 cm (Kyriacou *et al* 2001).

10. Clinical investigation 3: oesophageal PPG signals and blood oxygen saturation measurements in cardiothoracic surgery patients

10.1. Clinical method

This study (Kyriacou *et al* 2002b, 2002c, 2003) investigated and compared oesophageal and finger PPGs and SpO₂s in patients undergoing high-risk operations, such as hypothermic cardiothoracic bypass surgery, in whom conventional pulse oximetry might fail due to poor peripheral circulation. Forty nine adult patients were recruited for this study (Kyriacou *et al* 2003). Having previously found (Kyriacou *et al* 1999, 2001) that PPG signals in the mid oesophagus (20–25 cm from the upper lip) are of large amplitude, the oesophageal pulse oximeter probe was advanced into the oesophagus at 30 cm from the lips. Photoplethysmographic signals were observed at various depths in the oesophagus until the site that provided the highest amplitude PPG signals and small ventilator artefact (synchronous modulation of the oesophageal PPG traces at the frequency of the ventilator) was determined. During the oesophageal measurements, values of blood oxygen saturation from a commercial transmission type finger pulse oximeter (Marquette, Tram 200A; Marquette Electronics, Milwaukee, WI) were also recorded.

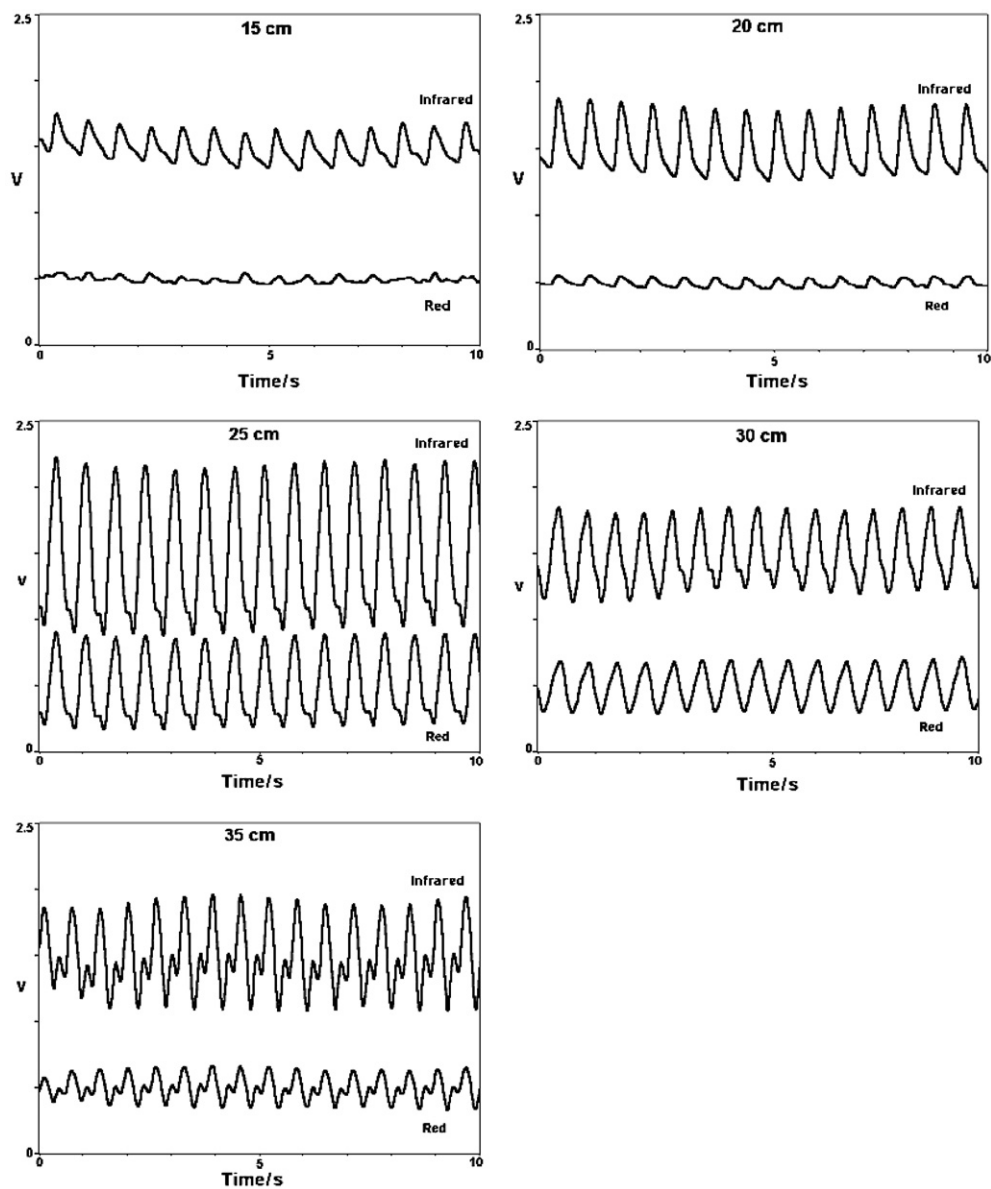

Figure 15. PPG signals at red and infrared wavelengths from five oesophageal depths. The infrared PPG trace is at the top and has the larger amplitude in each case. The amplitudes of both red and infrared signals increase as the depth increases from 15 cm reaching a maximum at 25 cm.

Monitoring with the oesophageal pulse oximeter was performed intermittently (Kyriacou *et al* 2003) during the various periods of the operation (during induction of anaesthesia, prior to commencing cardiopulmonary bypass, after bypass and postoperative in the intensive care unit). During the above recording periods, samples of arterial blood were taken and analysed by an Instrumentation Laboratories IL 482 CO-oximeter or an Instrumentation Laboratories IL BG-1400 Blood Gas Analyser (BGA) (Instrumentation Laboratories, Lexington, MA, USA).

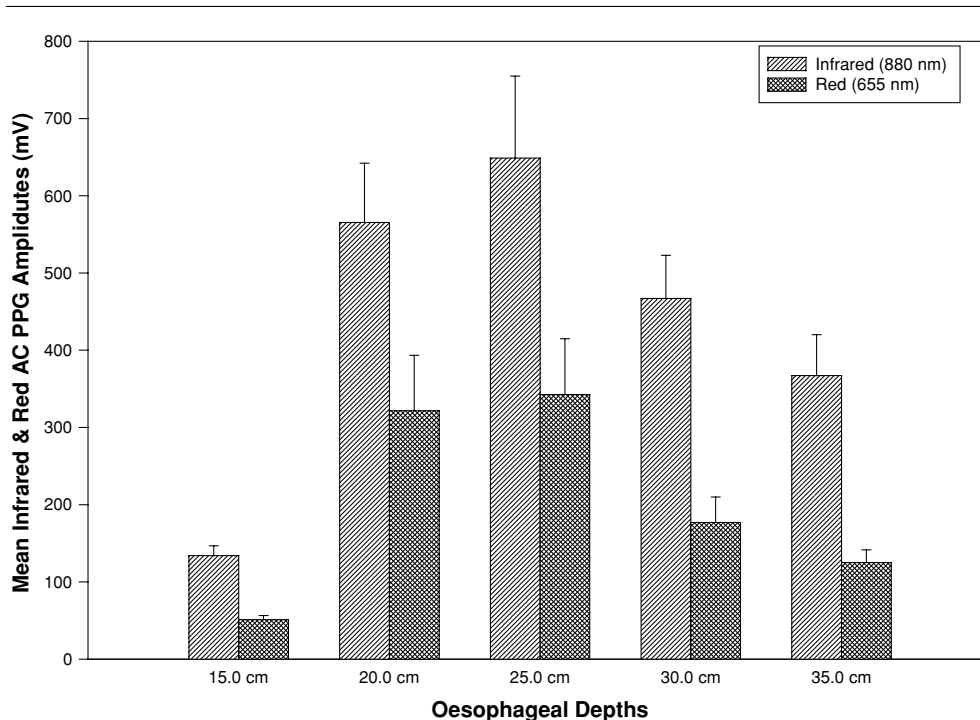

Figure 16. Mean (std error) PPG peak-to-peak amplitudes at two wavelengths and five oesophageal depths.

10.2. Results

10.2.1. Results from the investigation of PPG signals in cardiac patients. Measurable PPG traces at red and infrared wavelengths were obtained in the oesophagus in all 49 patients (Kyriacou *et al* 2002b). Figure 17 depicts typical traces from one patient undergoing cardiopulmonary bypass surgery during the various monitoring periods as described above (probe depth 17 cm from the lips). Figure 17(a) shows oesophageal and finger ac PPGs, obtained at both wavelengths, and ECG signals recorded prior to skin incision. The signals in figure 17(b) were recorded just before sternotomy. In figure 17(c) the signals were recorded after the chest was open. Figure 17(d) shows the transition from before bypass to being on cardiopulmonary bypass. When the heart–lung machine was switched on (indicated in the figure as ‘on bypass’) the pulsatile PPG signals disappeared within the next 20–25 s. The ECG trace on bypass shows a variable high frequency activity as expected. Figures 17(e) and (f) show PPG and ECG signals after bypass, during closing of the chest and postoperatively in the intensive care unit, respectively.

The chosen oesophageal monitoring depths ranged from 14 cm to 28 cm, measured from the upper lip (mean \pm SD: 17.8 \pm 3.3 cm). The optimal oesophageal monitoring depth for each patient was considered the depth at which oesophageal PPGs with a good signal-to-noise ratio and acceptable ventilator artefact (synchronous modulation in the form of a sinusoidal baseline shift in time with the approximately 5 s period of the ventilatory cycle) could be obtained (Kyriacou *et al* 1999, 2001). The mean \pm SD of the ac PPG amplitudes at both wavelengths at the different oesophageal monitoring depths for all cardiothoracic patients were within the same ranges as those obtained in an earlier PPG amplitude study at five oesophageal depths in healthy anaesthetized patients (Kyriacou *et al*, 2001, 2002b).

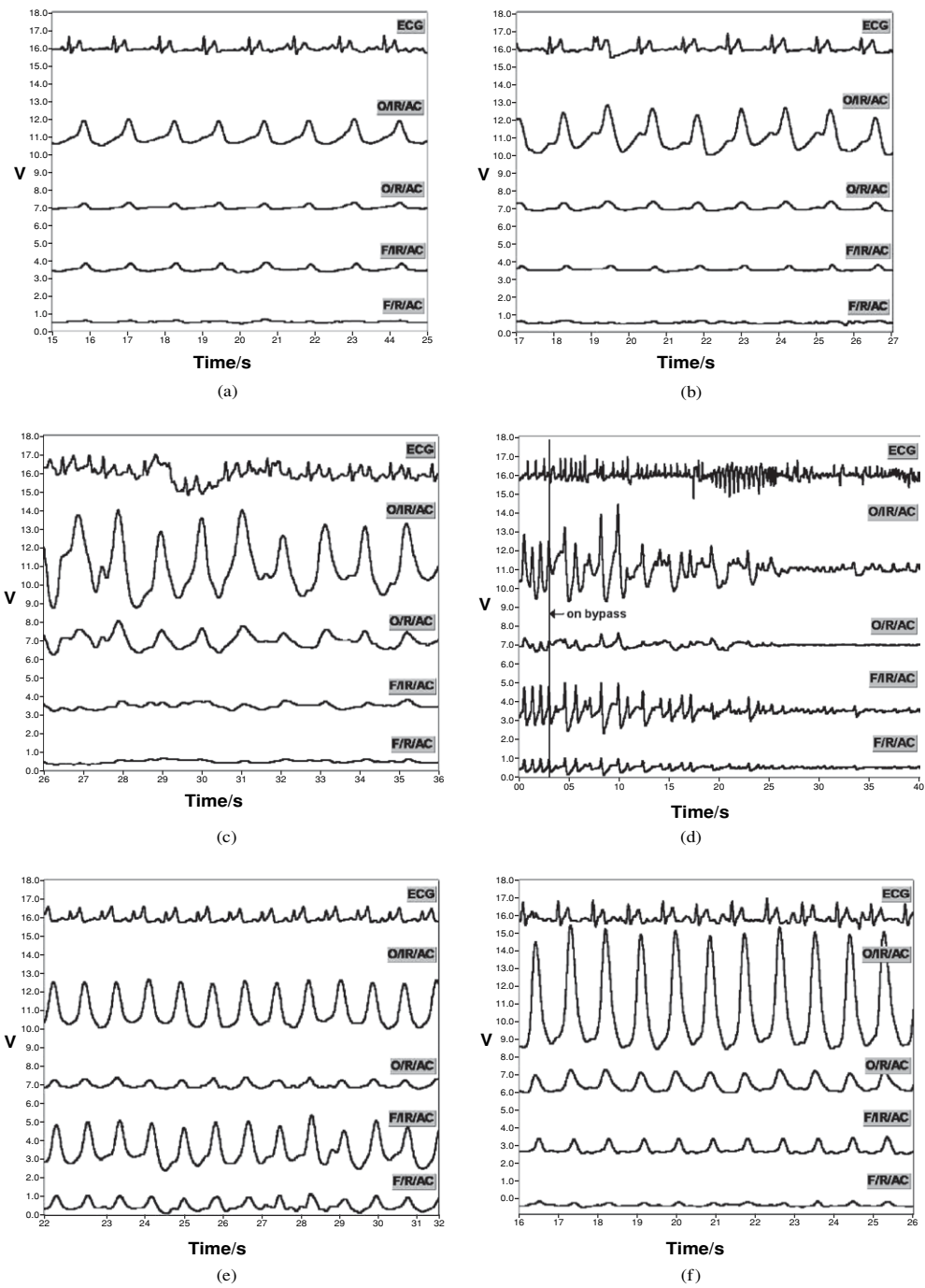

Figure 17. Oesophageal, finger and ECG traces obtained from an anaesthetized patient undergoing cardiopulmonary bypass surgery (probe depth 17 cm from lips): (a) prior to skin incision, (b) in operating theatre before sternotomy, (c) after sternotomy, (d) during bypass transition (before bypass, on bypass), (e) closing the chest, (f) in intensive care unit. O/IR/AC—oesophageal infrared ac PPG, O/R/AC—oesophageal red ac PPG, F/IR/AC—finger infrared ac PPG, F/R/AC—finger red ac PPG.

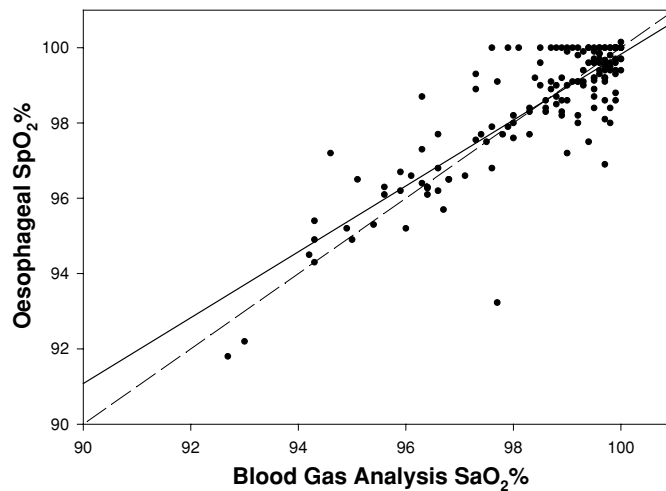

Figure 18. Plot of SpO₂ measurements obtained from the oesophageal pulse oximeter (OES SpO₂) against SaO₂ from blood gas analysis (BGA SaO₂) for 49 patients. The solid line represents the best fit linear regression line: (OES SpO₂) = 12.3 + 0.88 (BGA SaO₂), $r^2 = 0.74$, SEE = 0.86, $n = 155$, $p < 0.001$. The dashed line represents identity.

10.2.2. *Comparisons of blood oxygen saturation measurements from the oesophageal and commercial finger pulse oximeters with those from blood gas analysis.* A total of 155 sets of data points from the 49 patients were used for the regression analysis (Kyriacou *et al* 200c). A plot of SpO₂ readings obtained from the reflectance oesophageal pulse oximeter (OES SpO₂) against the SaO₂ values from the blood gas analyser (BGA SaO₂) is shown in figure 18. The equation of the best fit linear regression line is: (OES SpO₂) = 12.3 + 0.88 (BGA SaO₂) (the solid line in figure 18); $r^2 = 0.74$; standard error of estimate (SEE) = 0.86; $p < 0.001$. The dashed line represents the line of identity. The median (interquartile range [range]) of the differences between the blood oxygen saturation values obtained with the oesophageal pulse oximeter and those obtained from blood gas analysis (OES SpO₂ – BGA SaO₂) is 0.00 (–0.30, 0.3 [7.07]).

Figure 19 shows a plot of SpO₂ readings obtained from the commercial finger pulse oximeter (CF SpO₂) against the SaO₂ values from the blood gas analyser. The equation of the best fit linear regression line was: (CF SpO₂) = 26.8 + 0.73 (BGA SaO₂); $r^2 = 0.39$; SEE = 1.48; $p < 0.001$. The dashed line represents the equal value line. The median (interquartile range [range]) of the differences between the blood gas analyser and the commercial finger pulse oximeter results (BGA SaO₂ – CF SpO₂) is 0.10 (–0.40, 1.07 [10.60]).

10.2.3. *Comparisons of blood oxygen saturation measurements from the oesophageal and commercial finger pulse oximeter with those from CO-oximetry.* In a subset of 17 patients, arterial blood was also analysed by CO-oximetry, providing 36 sets of data for regression analysis.

A plot of oesophageal SpO₂ readings against the SaO₂ values from the CO-oximeter is shown in figure 20. The equation of the best fit linear regression line is: (OES SpO₂) = 10.1 + 1.1 (CO-ox SaO₂) (the solid line in figure 20); $r^2 = 0.83$; SEE = 0.71; $p < 0.001$. The dashed line represents the equal value line. The mean (\pm SD) of the differences between the oesophageal pulse oximeter SpO₂ values and the corresponding CO-oximeter readings (OES SpO₂ – CO-ox SaO₂) is 0.73 \pm 0.72%.

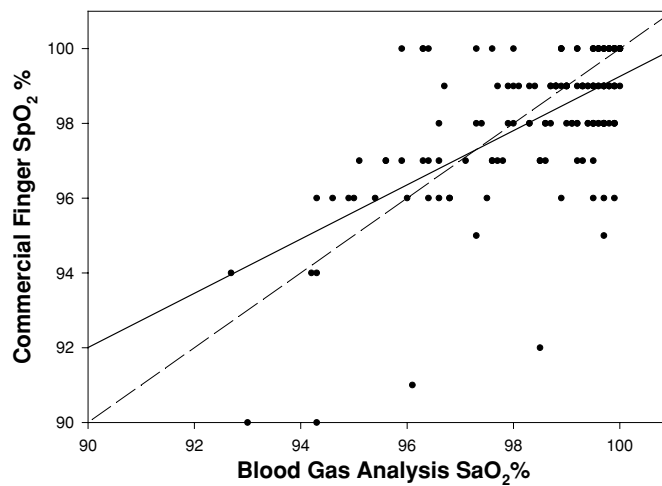

Figure 19. Plot of SpO_2 measurements obtained from the commercial finger pulse oximeter (CF SpO_2) against SaO_2 from blood gas analysis (BGA SaO_2) for 49 patients. The solid line represents the best fit linear regression line: $(\text{CF } \text{SpO}_2) = 26.8 + 0.73 (\text{BGA } \text{SaO}_2)$, $r^2 = 0.39$, $\text{SEE} = 1.48$, $n = 155$, $p < 0.001$. The dashed line represents identity.

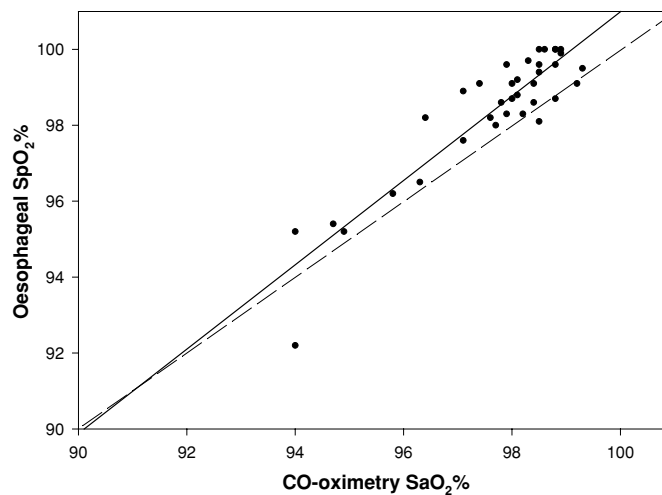

Figure 20. Plot of SpO_2 measurements obtained from the oesophageal pulse oximeter (OES SpO_2) against SaO_2 from the CO-oximetry (CO-ox SaO_2) for 17 patients. The solid line represents the best fit linear regression line: $(\text{OES } \text{SpO}_2) = 10.1 + 1.1 (\text{CO-ox } \text{SaO}_2)$, $r^2 = 0.83$, $\text{SEE} = 0.71$, $n = 36$, $p < 0.001$. The dashed line represents identity.

Figure 21 shows a plot of commercial finger SpO_2 readings against the SaO_2 values from the CO-oximeter. The equation of the best fit linear regression line is: $(\text{CF } \text{SpO}_2) = 4.9 + 0.9 (\text{CO-ox } \text{SaO}_2)$; $r^2 = 0.55$; $\text{SEE} = 1.26$; $p < 0.001$. The dashed line represents the equal value line. The mean and standard deviation of the differences between the commercial finger pulse oximeter and the CO-oximeter readings ($\text{CF } \text{SpO}_2 - \text{CO-ox } \text{SaO}_2$) are $0.61 \pm 1.23\%$.

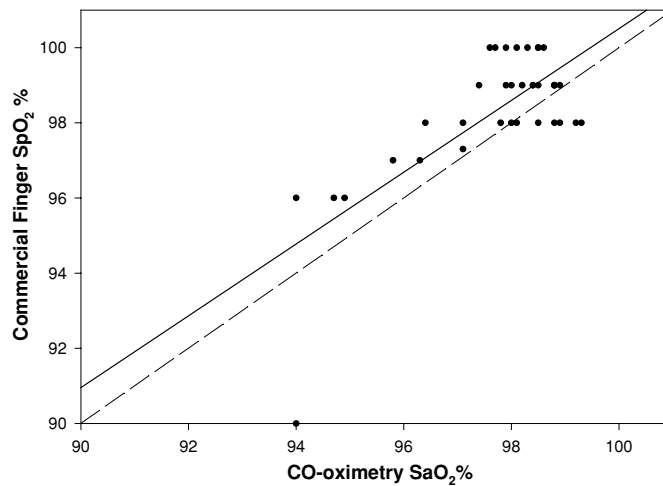

Figure 21. Plot of SpO₂ measurements obtained from the commercial finger pulse oximeter (CF SpO₂) against SaO₂ from the CO-oximetry (CO-ox SaO₂) for 17 patients. The solid line represents the best fit linear regression line: $(CF\ SpO_2) = 4.9 + 0.9 (CO\text{-}ox\ SaO_2)$, $r^2 = 0.55$, SEE = 1.26, $n = 36$, $p < 0.001$. The dashed line represents identity.

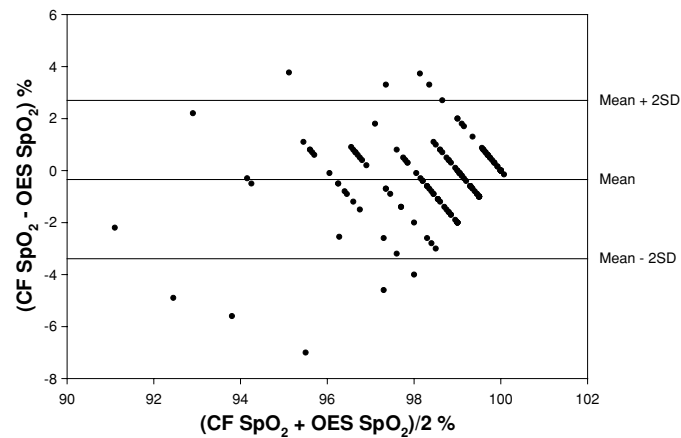

Figure 22. The difference between blood oxygen saturation values from the commercial finger pulse oximeter (CF SpO₂) and SpO₂ readings obtained from the reflectance oesophageal pulse oximeter (OES SpO₂) plotted against their mean for 49 patients.

10.2.4. Comparisons of blood oxygen saturation measurements from the oesophageal and commercial finger pulse oximeters. The 155 sets of blood oxygen saturation data points from 49 patients were used to compare the oesophageal and the commercial finger pulse oximeters. Since neither can be regarded as a ‘gold’ standard, the *between-method differences* analysis as suggested by Bland and Altman (1986) was used to compare these two pulse oximeters. Figure 22 is a plot of the difference between the commercial finger (CF) and oesophageal (OES) SpO₂ values against their mean. As no obvious relation between the difference and the mean is revealed in figure 22, a calculation of the bias, estimated by the mean difference (d) and the standard deviation of the differences (s) was performed to assess the degree of agreement between the two methods. The bias (d) (commercial pulse oximeter minus oesophageal pulse oximeter) was -0.3% and the standard deviation (s) was 1.5% . The

Table 1. Blood oxygen saturation measurements from the oesophageal pulse oximeter and blood gas analysis in patients in whom peripheral pulse oximetry failed.

Patients	BGA SaO ₂ %	Oesophageal SpO ₂ %	Finger SpO ₂ %
1	97.0	97.1	Failed
2	97.7	97.0	Failed
3	98.7	98.5	Failed
	99.0	99.0	Failed
4	97.9	97.9	Failed
5	98.9	98.8	Failed
	98.0	98.9	Failed

limits of agreement for the SpO₂ data (commercial finger and oesophageal) were

$$d - 2s = -0.3 - (2 \times 1.5) = -3.3\%$$

$$d + 2s = -0.3 + (2 \times 1.5) = 2.7\%.$$

10.2.5. Failure of commercial pulse oximeter. Of the 49 patients included in the study, it was found that five patients (10.2%) had one or more periods of at least ten consecutive minutes, during which the commercial finger pulse oximeter failed to record pulsatile PPG signals and display SpO₂ values, despite being correctly positioned on the finger. The oesophageal pulse oximeter operated successfully throughout these periods of finger monitoring failure. In four of these patients, the finger pulse oximeter failed postoperatively in the intensive care unit (within the first half hour after completion of the surgery), and in the fifth patient, the failure occurred in the operating theatre before bypass. Results from arterial blood gas analysis performed during these periods of failed finger pulse oximetry are shown in table 1, and demonstrate good agreement (mean difference = 0.0%) between the oxygen saturation values obtained from the oesophageal pulse oximeter and the blood gas analyser.

11. Clinical investigation 4: oesophageal blood oxygen saturation measurements in burned patients

The oesophageal pulse oximeter developed by Kyriacou (2001) has also been used in a small clinical study on burned patients (Pal *et al* 2005). In this group of patients, standard sites for monitoring SpO₂ such as fingers or toes may be affected by the burn or they might be unsuitable due to the use of tourniquets during surgery. Seven patients with major burns were recruited for the study. The total body surface area burnt ranged between 28% and 90%.

The oesophageal PPG signals recorded from this group of patients were of good quality and large amplitude. A plot of SpO₂ readings obtained from the reflectance oesophageal pulse oximeter (OES SpO₂) against the SaO₂ values from the CO-oximeter is shown in figure 23. The equation of the best fit linear regression line is: (OES SpO₂) = 33.278 + 0.666 (CO-ox SaO₂) (the solid line in figure 23), $r^2 = 0.49$, standard error of estimate (SEE) = 0.64, $p < 0.001$. The dashed line represents the line of identity.

12. Clinical investigation 5: oesophageal pulse oximetry in neonatal and paediatric patients

The oesophageal pulse oximeter probe developed by Kyriacou (2001) has been modified (Kyriacou *et al* 2002a) to fit into a conventional disposable transparent stomach tube, 12 French gauge. Such a size stomach tube is used routinely in anaesthetized babies and children.

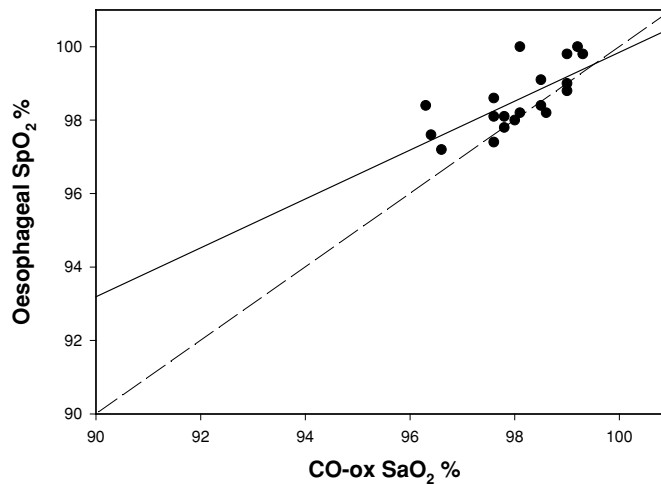

Figure 23. Plot of SpO₂ measurements obtained from the oesophageal pulse oximeter against SaO₂ from the CO-oximetry for seven patients. The solid line represents the best fit linear regression line: (OES SpO₂) = 33.278 + 0.666 (CO-ox SaO₂), $r^2 = 0.49$, standard error of estimate (SEE) = 0.64, $p < 0.001$. The dashed line represents the line of identity.

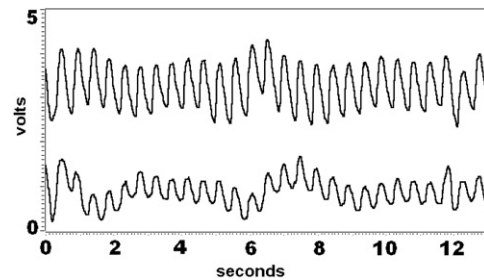

Figure 24. Typical PPG traces obtained from a neonatal human oesophagus at two wavelengths, infrared (top trace) and red (bottom trace).

In this pilot study, five patients were studied in the intensive care unit (Kyriacou *et al* 2002a). The oesophageal SpO₂ probe was advanced through the mouth to a maximum depth of 15 cm from the lips. During the oesophageal measurements, values of blood oxygen saturation from a commercial foot pulse oximeter were also recorded.

Measurable PPG traces of good quality were obtained in the oesophagus in all patients. Figure 24 depicts typical PPG signals from the oesophagus of a 3.2 kg, 5 day old neonate. An Altman and Bland (1983) plot of the difference between blood oxygen saturation values from the commercial pulse oximeter and those from the oesophageal pulse oximeter against their mean showed that the bias and the limits of agreement between the oesophageal and toe pulse oximeters were -0.3% and -1.7% to 1.0% .

13. Other applications of the oesophageal pulse oximeter

13.1. Introduction

The oesophageal pulse oximeter (Kyriacou 2001) has also been used to investigate photoplethysmographic signals in human visceral organs (Crerar-Gilbert *et al* 2002). The

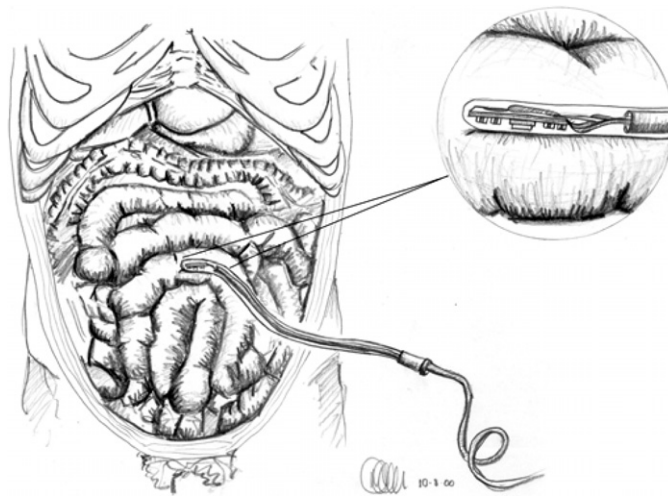

Figure 25. Reflectance oesophageal pulse oximeter probe placed on the surface of the human bowel.

hypothesis underlying that investigation is that blood oxygen saturation from an extremity such as the finger may not accurately reflect splanchnic oxygen saturation values. In many critically ill patients, poor tissue oxygenation is due to disordered regional distribution of blood flow, despite high global blood flow and oxygen delivery. Splanchnic ischaemia may ultimately lead to cellular hypoxia and necrosis and may well contribute to the development of multiple organ failure and increased mortality (Lemaire *et al* 1996). Rapid detection of a significant change in tissue oxygenation could enable earlier and more successful intervention and restoration of splanchnic blood flow and should improve survival in critically ill patients (Lemaire *et al* 1996).

Techniques used to measure tissue oxygenation such as polarographic oxygen electrodes, luminescent oxygen probes, magnetic resonance spectroscopy and positron emission tomography remain research tools (Lemaire *et al* 1996). Manual fluid tonometry for estimating intestinal hypoxia is expensive, intermittent, operator dependent and time consuming; the recently introduced automatic device is more convenient but is even more expensive (Lemaire *et al* 1996). Methods such as laser Doppler, Doppler ultrasound and intravenous fluorescein have been previously explored to assess intestinal ischaemia in animals (Pearce *et al* 1987, Ferrara *et al* 1988, Denobile *et al* 1990, Macdonald *et al* 1993). Many of these techniques are complex and expensive and none of them directly measures oxygenation. Therefore, there is a need for a simple, reliable and continuous method for estimating visceral organ SpO₂. Animal studies have also shown that pulse oximetry could be used to monitor intestinal oxygen saturation (Macdonald *et al* 1993). The feasibility of estimating blood oxygen saturation in humans has been demonstrated by a study using a commercial transmission pulse oximeter on the colon (Ouriel *et al* 1988). However, there are difficulties in applying commercial pulse oximeters to measurements in abdominal human organs because the probes are unsuitable and are not easily sterilizable. Moreover, none of the currently available probes could be left in the abdomen for prolonged postoperative monitoring.

As a preliminary to constructing a suitable pulse oximeter for monitoring abdominal organ SpO₂, the oesophageal pulse oximeter has been used for the measurement of PPG signals from the surface of the bowel, liver and kidney. The aim was to develop techniques to facilitate

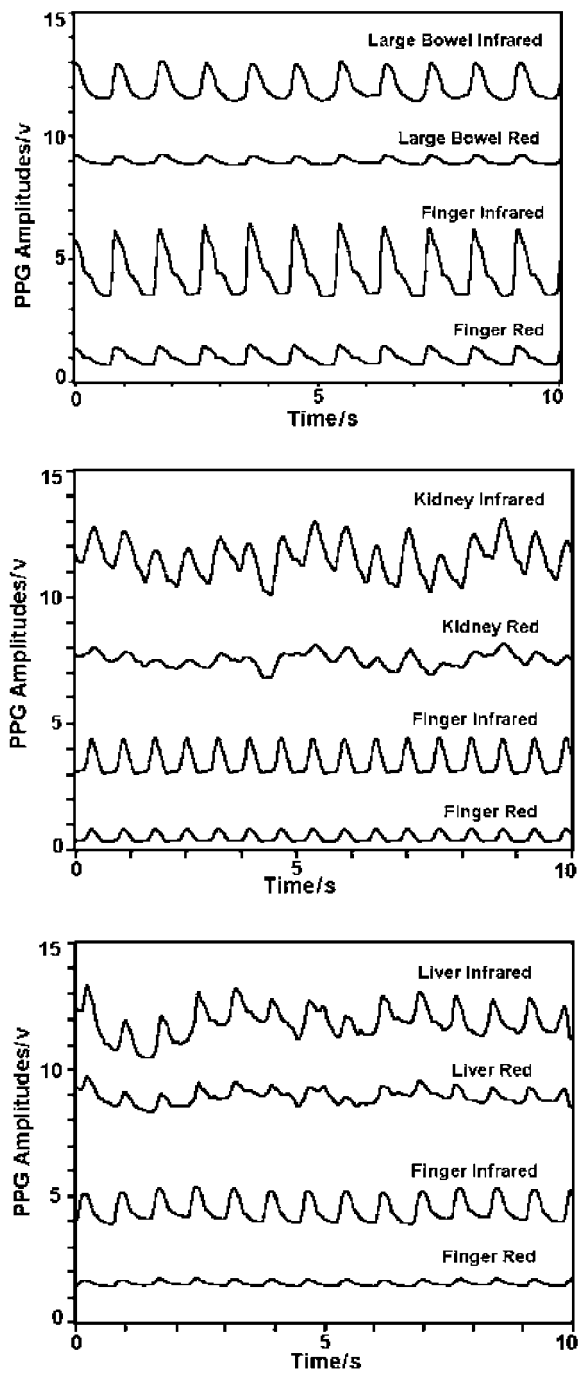

Figure 26. PPG traces from simultaneous measurements at various abdominal organs (bowel, kidney and liver) and the finger.

measurements on patients with compromised splanchnic circulation, which will be useful both intraoperatively and in intensive care.

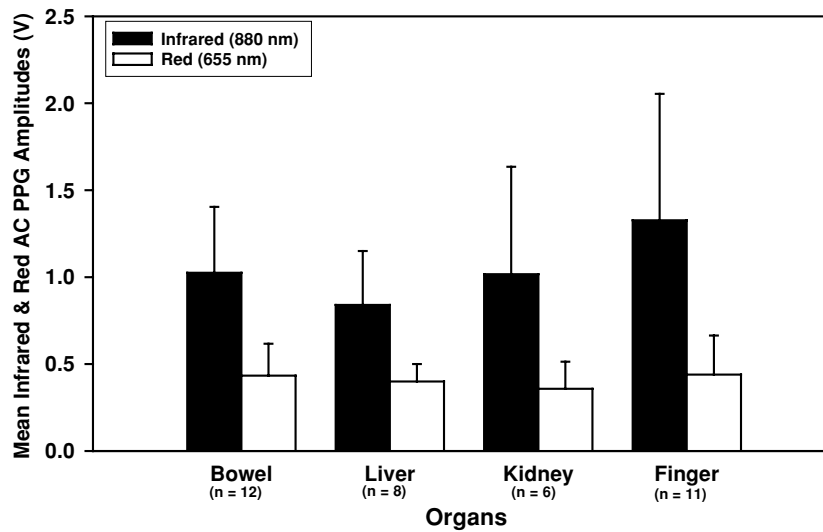

Figure 27. AC peak-to-peak amplitudes, mean (\pm SD), at two wavelengths from the three abdominal organs and the finger.

13.2. Clinical method

Twelve adult patients undergoing elective laparotomy under general anaesthesia were studied (Crerar-Gilbert *et al* 2002). The oesophageal probe was inserted into a sealed and sterilized disposable size 20 French gauge gastric tube. The gastric tube containing the probe was then applied gently to the surface of each abdominal organ so that the emitted light was reflected from its surfaces (figure 25). The identical reflectance finger probe was placed on the finger of the patient. Simultaneous PPG traces from each abdominal organ and the finger were recorded for approximately 2 min.

13.3. Results

Crerar-Gilbert *et al* (2002) reported that measurable PPG signals were always obtained from the surface of the bowel in all 12 patients, depending on intra-operative accessibility from the liver (eight patients) and the kidney (six patients). PPG signals with similar amplitudes and reasonably high signal-to-noise ratios were obtained from all investigated abdominal organs (figure 26). The PPG amplitudes from both hollow and solid abdominal organs were, on average, approximately the same as those obtained simultaneously from a finger for both wavelengths, although there is considerable variability.

Figure 27 shows the mean peak-to-peak PPG amplitudes and standard deviations from all investigated abdominal organs and the finger. Paired *t*-tests showed that there were no statistically significant differences between the PPG amplitudes recorded from the abdominal organs and those from the finger (Crerar-Gilbert *et al* 2002).

14. Conclusions

Pulse oximetry is a non-invasive photometric technique that provides information about the arterial blood oxygen saturation (SpO_2) and heart rate, and has widespread clinical

applications. Pulse oximeters estimate arterial oxygen saturation by shining light at two different wavelengths, red and infrared, through vascular tissue. In this method, the ac pulsatile photoplethysmographic (PPG) signal associated with cardiac contraction is assumed attributable solely to the arterial blood component. The amplitudes of the red and infrared ac PPG signals are sensitive to changes in arterial oxygen saturation because of differences in the light absorption of oxygenated and deoxygenated haemoglobin at these two wavelengths. From the ratios of these amplitudes, and the corresponding dc photoplethysmographic components, arterial blood oxygen saturation (SpO₂) is estimated.

Although generally reliable, pulse oximeters do fail in patients with compromised peripheral perfusion. Pulse oximetry is a pulse-dependent technique, and any significant reduction in the amplitude of the pulsatile component of the photoplethysmographic signal can lead to dubious values for blood oxygen saturation (SpO₂) or complete failure. Hence, pulse oximeters require adequate peripheral perfusion to operate accurately. When peripheral perfusion is poor, as in states of hypovolaemia, hypothermia and vasoconstriction, oxygenation readings become unreliable or cease. Such clinical situations occur, for example, after prolonged operations such as cardiac, vascular, reconstructive or neuro-surgery. The problem arises because conventional pulse oximetry sensors must be attached to the most peripheral parts of the body, such as finger, ear or toe, where pulsatile flow is most easily compromised. The introduction of the oesophageal pulse oximeter was found to be reliable and accurate in cases of poor peripheral perfusion where peripheral pulse oximeters failed to estimate oxygen saturation. These results show that in general the arterial blood circulation to the oesophagus is less subject to peripheral vasoconstriction and decreased PPG amplitudes than are the peripheral sites used for pulse oximetry such as the finger. Therefore, the human oesophagus not only can be used as an alternative SpO₂ monitoring site but also can be used as a possible SpO₂ monitoring site in cases of poor peripheral circulation where peripheral pulse oximeters fail. This novel monitoring site, the oesophagus, can also find applications in patients who have burns or other serious injuries where the oesophagus may be the only available site for pulse oximetry monitoring. In addition, the application of the oesophageal pulse oximeter in hollow and solid abdominal organs supported the hypothesis that pulse oximetry may be used as a blood oxygen saturation monitoring technique for abdominal organs for intraoperative and prolonged postoperative monitoring.

In summary, the use of this novel pulse oximeter has proven for the first time that the whole of the oesophagus is a reliable and accurate monitoring site for blood oxygen saturation in healthy patients and in sick patients in whom conventional pulse oximetry might fail due to poor peripheral circulation.

References

- Alexander C M, Teller L E and Gross J B 1989 Principles of pulse oximetry: theoretical and practical considerations *Anesth. Analg.* **68** 368–76
- Altman D G and Bland J M 1983 Measurement in medicine: the analysis of method comparison studies *Statistician* **32** 307–17
- Anderson I D, Woodford M, De Dombal F T and Irving M 1988 Retrospective study of 1000 deaths from injury in England and Wales *Br. Med. J.* **296** 1305–8
- Anonymous 2003 Next generation pulse oximetry *Health Devices* **32** 49–103
- Atlee J L and Bratanow N 1995 Comparison of surface and esophageal oximetry in man [abstract] *Anesthesiology* **83** A455
- Barker S J, Hyatt J, Shah N K and Kao Y J 1993 The effect of sensor malpositioning on pulse oximeter accuracy during hypoxemia *Anesthesiology* **79** 248–54
- Barker S J and Tremper K K 1987 The effect of carbon monoxide inhalation on pulse oximetry and transcutaneous PO₂ *Anesthesiology* **66** 677–9

- Barker S J, Tremper K K and Hyatt J 1989 Effects of methemoglobinemia on pulse oximetry and mixed venous oximetry *Anesthesiology* **70** 112–7
- Bickler P E, Feiner J R and Severinghaus J W 2005 Effects of skin pigmentation on pulse oximeter accuracy at low saturation *Anesthesiology* **102** 715–9
- Bland J M and Altman D G 1986 Statistical methods for assessing agreement between two methods of clinical measurement *Lancet* **1** 307–10
- Block F E and Detko G J 1986 Minimizing interference and false alarms from electrocautery in the Nellcor N-100 pulse oximeter *J. Clin. Monit.* **2** 203–5
- Borum S E 1997 The successful use of transesophageal pulse oximetry in a patient in whom peripheral pulse oximetry was unobtainable [case report] *Anesth. Analg.* **85** 514–6
- Bowes W A, Corke B C and Hulka J 1989 Pulse oximetry: a review of the theory, accuracy and clinical applications *Obstet. Gynaecol.* **74** 541–6
- Challoner A V J 1979 *Photoelectric Plethysmography for Estimating Cutaneous Blood Flow* (New York: Academic) chapter 6 pp 125–51
- Chan M M, Chan M M and Chan E D 2003 What is the effect of fingernail polish on pulse oximetry? *Chest* **123** 2163–4
- Clayton D G, Webb R K, Ralston A C, Duthie D and Runciman W B 1991 A comparison of the performance of 20 pulse oximeters under conditions of poor perfusion *Anaesthesia* **46** 3–10
- Cote C J, Goldstein E A, Fuchsman W H and Hoaglin D C 1988 The effect of nail polish on pulse oximetry *Anesth. Analg.* **67** 683–6
- Crerar-Gilbert A, Kyriacou P A, Jones D P and Langford R M 2002 Assessment of photoplethysmographic signals for the determination of splanchnic oxygen saturation in humans *Anaesthesia* **57** 442–5
- Delpy D T 1988 Developments in oxygen monitoring *J. Biomed. Eng.* **10** 533–40
- Denobile J, Guzzetta P and Patterson K 1990 Pulse oximetry as a means of assessing bowel viability *J. Surg. Res.* **48** 21–3
- De Kock J P, Tarassenko L, Glynn C J and Hill A R 1993 Reflectance pulse oximetry measurements from the retinal fundus *IEEE Trans. Biomed. Eng.* **40** 817–23
- Dildy G A 2001 Fetal pulse oximetry: current issues *J. Perinat. Med.* **29** 5–13
- Dildy G A 2004 Fetal pulse oximetry: a critical appraisal *Best Pract. Res. Clin. Obstet. Gynaecol.* **8** 477–84
- Dildy G A, Clark S L and Loucks C A 1994 Intrapartum fetal pulse oximetry: the effects of maternal hyperoxia on fetal arterial oxygen saturation *Am. J. Obstet. Gynecol.* **171** 1120–4
- Dorlas J C and Nijboer J A 1985 Photo-electric plethysmography as a monitoring device in anaesthesia: application and interpretation *Br. J. Anaesth.* **57** 524–30
- Drummond G B and Park G R 1984 Arterial oxygen saturation before intubation of the trachea *Br. J. Anaesth.* **56** 987–93
- Ferrara J J, Dyess D L, Lasecki M, Kinsey S, Donnell C and Jurkovich G J 1988 Surface oximetry: a new method to evaluate intestinal perfusion *Am. Surg.* **54** 10–4
- Fine I and Weinreb A 1995 Multiple scattering effect in transmission pulse oximetry *Med. Biol. Eng. Comput.* **33** 709–12
- Finlay J C and Foster T H 2004 Hemoglobin oxygen saturations in phantoms and *in vivo* from measurements of steady-state diffuse reflectance at a single, short source–detector separation *Med. Phys.* **31** 1949–59
- Fluck R R Jr, Schroeder C, Frani G, Kropf B and Engbretson B 2003 Does ambient light affect the accuracy of pulse oximetry? *Respir. Care* **48** 677–80
- Freund P R, Overand P T, Cooper J, Jacobson L, Bosse S, Walker B, Posner K L and Cheney F W 1991 A prospective study of intraoperative pulse oximetry failure *J. Clin. Monit.* **7** 253–8
- Gardosi J O, Schram C M and Symonds E M 1991 Adaptation of pulse oximetry for fetal monitoring during labour *Lancet* **337** 1265–7
- Goldman J M, Petterson M T, Kopotic R J and Barker S J 2000 Masimo signal extraction pulse oximetry *J. Clin. Monit. Comput.* **16** 475–83
- Hanning C D and Alexander-Williams J M 1995 Pulse oximetry: a practical review *Br. Med. J.* **311** 367–70
- Hanowell L, Eisele J H and Downs D 1987 Ambient light affects pulse oximeters *Anesthesiology* **67** 864–5 (letter)
- Higgins J L and Fronck A 1986 Photoplethysmographic evaluation of the relationship between skin reflectance and blood volume *J. Biomed. Eng.* **8** 130–6
- Hovagim A R, Vitkun S A, Manecke G R and Reiner R 1989 Arterial oxygen saturation in adult dental patients receiving conscious sedation *J. Oral Maxillofac. Surg.* **47** 936–9
- Jay G D, Hughes L and Renzi F P 1994 Pulse oximetry is accurate in acute anemia from hemorrhage *Ann. Emerg. Med.* **24** 32–5
- Kataria B K and Lampkins R 1986 Nail polish does not affect pulse oximetry saturation *Anesth. Analg.* **65** 824 (letter)

- Kelleher J F 1989 Pulse oximetry *J. Clin. Monit.* **5** 37–62
- Kelleher J F and Ruff R H 1989 The penumbra effect: vasomotion-dependent pulse oximeter artifact due to probe malposition *Anesthesiology* **71** 787–91
- Kessler M R, Eide T, Humayan B and Poppers P J 1986 Spurious pulse oximeter desaturation with methylene blue injection *Anesthesiology* **65** 435–6
- Kidd J F and Vickers M D 1989 Pulse oximeters: essential monitors with limitations *Br. J. Anaesth.* **62** 355–7
- Klauser C K, Christensen E E, Chauhan S P, Bufkin L and Magann E F 2005 Use of fetal pulse oximetry among high-risk women in labor: a randomized clinical trial *Am. J. Obstet. Gynecol.* **192** 1810–7
- Kyriacou P A 2001 Investigation of new electro-optical techniques for monitoring patients with compromised peripheral perfusion in anaesthesia *PhD Thesis* University of London
- Kyriacou P A, Moye A R, Choi D M A, Langford R M and Jones D P 2001 Investigation of the human oesophagus as a new monitoring site for blood oxygen saturation *Physiol. Meas.* **22** 223–32
- Kyriacou P A, Moye A R, Gregg A, Choi D M A, Langford R M and Jones D P 1999 A system for investigating oesophageal photoplethysmographic signals in anaesthetised patients *Med. Biol. Eng. Comput.* **37** 639–43
- Kyriacou P A, Powell S L, Jones D P and Langford R M 2003 Evaluation of oesophageal pulse oximetry in cardiothoracic surgery patients *Anaesthesia* **58** 422–7
- Kyriacou P A, Powell S, Langford R M and Jones D P 2002b Investigation of oesophageal photoplethysmographic signals and blood oxygen saturation measurements in cardiothoracic surgery patients *Physiol. Meas.* **23** 533–45
- Kyriacou P A, Powell S, Langford R M and Jones D P 2002c Oesophageal pulse oximetry utilizing reflectance photoplethysmography *IEEE Trans. Biomed. Eng.* **49** 1360–8
- Kyriacou P A, Wardhaugh A, Jones D P, Langford R M and Petros A J 2002a Investigation of photoplethysmographic signals in neonatal and paediatric patients *Intensive Care Med.* **28** (Suppl. 1) S111
- Lambert M A and Crinnion J 1989 The role of pulse oximetry in the accident and emergency department *Arch. Emerg. Med.* **6** 211–5
- Lemaire F *et al* 1996 Tissue hypoxia. How to detect, how to correct, how to prevent? *Intensive Care Med.* **22** 250–257
- Lindberg L G and Oberg P A 1991 Photoplethysmography: part 2. Influence of light source wavelength *Med. Biol. Eng. Comput.* **29** 48–54
- Macdonald P H, Dinda P K, Beck I T and Mercer C D 1993 The use of oximetry in determining intestinal blood flow *Surg. Gynecol. Obstet.* **176** 451–8
- Mannheimer P D, Casciani J R, Fein M E and Nierlich S L 1997a Wavelength selection for low-saturation pulse oximetry *IEEE Trans. Biomed. Eng.* **44** 148–58
- Mannheimer P D, Fein M E and Casciani J R 1997b Physio-optical considerations in the design of fetal pulse oximetry sensors *Eur. J. Obstet. Gynecol. Reprod. Biol.* **72** 9–19
- Marieb E N 1992 *Human Anatomy and Physiology* 2nd edn (Redwood City, CA: Benjamin/Cumming)
- Mendelson Y 1992 Pulse oximetry: theory and applications for noninvasive monitoring *Clin. Chem.* **38** 1601–7
- Mendelson Y and Ochs B D 1988 Noninvasive pulse oximetry utilizing skin reflectance photoplethysmography *IEEE Trans. Biomed. Eng.* **35** 798–805
- Minnich M E, Clark R B, Miller F C and Thompson D S 1990 Oxygen desaturation in women in labor *J. Reprod. Med.* **35** 693–6
- Moller J T, Johannessen N W, Espersen R, Ravlo O, Pedersen B D, Jensen P F, Rasmussen N H, Rasmussen L S, Pedersen T and Cooper J B 1993 Randomized evaluation of pulse oximetry in 20802 patients: II. Perioperative events and postoperative complications *Anesthesiology* **78** 445–53
- Moyle J T B 1994 *Principles and Practice Series: Pulse Oximetry* (London: BMJ Publishing Group)
- Moyle J T B 1996 Uses and abuses of pulse oximetry *Arch. Dis. Child.* **74** 77–80
- Nelson D A, Krupsky S, Pollack A, Aloni E, Belkin M, Vanzetta I, Rosner M and Grinvald 2005 Special report: noninvasive multi-parameter functional optical imaging of the eye *Ophthalm. Surg. Lasers Imaging* **36** 57–66
- Nijboer J A, Dorlas J C and Mahieu H F 1981 Photoelectric plethysmography—some fundamental aspects of the reflection and transmission method *Clin. Phys. Physiol. Meas.* **2** 205–15
- Ouriel K, Fiore W M and Geary J E 1988 Detection of occult colonic ischaemia during aortic procedures: use of an intraoperative photoplethysmographic technique *J. Vas. Surg.* **7** 5–9
- Pal S K, Kyriacou P A, Kumaran S, Fadheel S, Emamdee R, Langford R M and Jones D P 2005 Evaluation of oesophageal reflectance pulse oximetry in major burns patients *Burns* **31** 337–41
- Palve H 1992a Reflection and transmission pulse oximetry during compromised peripheral perfusion *J. Clin. Monit.* **8** 12–5
- Palve H 1992b Comparison of reflection and transmission pulse oximetry after open-heart surgery *Crit. Care Med.* **29** 48–51

- Palve H and Vuori A 1989 Pulse oximetry during low cardiac output and hypothermia states immediately after open heart surgery *Crit. Care Med.* **17** 66–9
- Pearce W H, Jones D N, Warren G H, Bartle E J, Whitehill T A and Rutherford R B 1987 The use of infrared photoplethysmography in identifying early intestinal ischaemia *Arch. Surg.* **122** 308–10
- Pologe J A 1987 Pulse oximetry: technical aspects of machine design *Int. Anesthesiol. Clin.* **35** 137–53
- Prielipp R C, Scuderi P E, Butterworth J F, Royster R L and Atlee J L 1996 Comparison of transesophageal pulse oximetry (TEPO) with peripheral surface pulse oximetry in CABG patients [abstract] *Anesthesiology* **85** 3A
- Prielipp R C, Scuderi P E, Hines M H, Atlee J L and Butterworth J F 2000 Comparison of a prototype esophageal oximetry probe with two conventional digital pulse oximetry monitors in aortocoronary bypass patients *J. Clin. Monit. Comput.* **16** 201–9
- Pullerits J, Burrows F A and Roy W L 1987 Arterial desaturation in healthy children during transfer to the recovery room *Can. J. Anaesth.* **34** 470–3
- Ralston A C, Webb R K and Runciman W B 1991 Potential errors in pulse oximetry: I. Pulse oximeter evaluation *Anaesthesia* **46** 202–6
- Reich D L, Imcenko A, Bodian C A, Kraidin J, Hofman J B, Deperio M, Konstadt S N, Kurki T and Eisenkraft J B 1996 Predictors of pulse oximetry data failure *Anesthesiology* **84** 859–64
- Reuss J L 2004 Factors influencing fetal pulse oximetry performance *J. Clin. Monit. Comput.* **8** 13–24
- Richardson T 2005 Methemoglobinemia and pulse oximetry *Resp. Care* **50** 386
- Ries A L, Prewitt L M and Johnson J J 1989 Skin color and ear oximetry *Chest* **96** 287–90
- Roberts V C 1982 Photoplethysmography—fundamental aspects of the optical properties of blood in motion *Trans. Inst. M C* **4** 101–6
- Romanes G J 1972 *Cunningham's Textbook of Anatomy* (London: Oxford University Press)
- Rosenberg J and Pedersen M H 1990 Nasal pulse oximetry overestimates oxygen saturation *Anaesthesia* **45** 1070–1
- Scheller M S, Unger R J and Kelner M J 1986 Effects of intravenously administered dyes on pulse oximeter readings *Anesthesiology* **65** 550–2
- Schmitt J M 1991 Simple photon diffusion analysis of the effects of multiple scattering on pulse oximetry *IEEE Trans. Biomed. Eng.* **38** 1194–203
- Severinghaus J W 1993 History and recent developments in pulse oximetry *Scand. J. Clin. Lab. Invest. Suppl.* **214** 105–11
- Severinghaus J W and Kelleher J F 1992 Recent developments in pulse oximetry *Anesthesiology* **76** 1018–38
- Severinghaus J W and Koh S O 1990 Effect of anemia on pulse oximeter accuracy at low saturations *J. Clin. Monit.* **6** 85–8
- Severinghaus J W and Naifeh K H 1987 Accuracy of response of six pulse oximeters to profound hypoxia *Anesthesiology* **67** 551–8
- Severinghaus J W and Spellman M J 1990 Pulse oximeter failure thresholds in hypotension and vasoconstriction *Anesthesiology* **73** 532–7
- Shimada Y, Yoshiya I, Oka N and Hamaguri K 1984 Effects of multiple scattering and peripheral circulation on arterial oxygen saturation measured with pulse-type oximeter *Med. Biol. Eng. Comput.* **22** 475–8
- Shvartsman L D and Fine I 2003 Optical transmission of blood: effect of erythrocyte aggregation *IEEE Trans. Biomed. Eng.* **50** 1026–33
- Sidi A, Paulus D A, Rush W, Gravenstein N N and Davis R F 1987 Methylene blue and indocyanine green artifactually lower oximetry readings of oxygen saturation *J. Clin. Monit.* **3** 249–56
- Sinex J E 1999 Pulse oximetry: principles and limitations *Am. J. Emerg. Med.* **17** 59–66
- Trang H, Boureghda S and Leske V 2004 Sleep desaturation: comparison of two oximeters *Pediatr. Pulmonol.* **37** 76–80
- Tremper K K and Barker S J 1989 Pulse oximetry *Anesthesiology* **70** 98–108
- Tyler I L, Tantisira B, Winter P M and Motoyama E K 1985 Continuous monitoring of arterial oxygen saturation with pulse oximetry during transfer to the recovery room *Anesth. Analg.* **64** 1108–12
- Vicenzi M N, Gombotz H, Krenn H, Dorn C and Rehak P 2000 Transesophageal versus surface pulse oximetry in intensive care unit patients *Crit. Care Med.* **28** 2268–70
- Volgyesi G A and Spahr-Schopfer I 1991 Does skin pigmentation affect the accuracy of pulse oximetry? An *in vitro* study *Anesthesiology* **75** A406 (abstract)
- Wahr J A, Tremper K K and Diab M 1995 Pulse oximetry *Respir. Care Clin. N Am.* **1** 77–105
- Webster J G 1997 *Design of Pulse Oximeters* (Bristol: Institute of Physics Publishing)
- Welch J 2005 Pulse oximeters *Biomed. Instrum. Technol.* **39** 125–30
- Wray S, Cope M, Delpy D T, Wyatt J S and Reynolds E O R 1988 Characterization of the near infrared absorption spectra of cytochrome aa₃ and hemoglobin for the non-invasive monitoring of cerebral oxygenation *Biochim. Biophys. Acta* **933** 184–92

- Wukitsch M W, Petterson M T, Tobler D R and Pologe J A 1988 Pulse oximetry: analysis of theory, technology and practice *J. Clin. Monit.* **4** 290–301
- Yilmaz E N, Vahl A C, van Rij G, Nauta S H, Brom H L and Rauwerda J A 1999 Endoluminal pulse oximetry of the sigmoid colon and the monitoring of the colonic circulation *Cardiovasc. Surg.* **7** 704–9
- Yoshiya I, Shimada Y and Tanaka K 1980 Spectrophotometric monitoring of arterial oxygen saturation in the fingertip *Med. Biol. Eng. Comput.* **18** 27–32