

 Open access • Journal Article • DOI:10.1103/PHYSREVLETT.118.150401

Pumped-Up SU(1,1) Interferometry — [Source link](#)

Stuart S. Szigeti, Robert J. Lewis-Swan, Simon A. Haine

Institutions: University of Queensland, University of Sussex

Published on: 11 Apr 2017 - Physical Review Letters (American Physical Society)

Topics: Interferometry

Related papers:

- [Quantum-Enhanced Sensing Based on Time Reversal of Nonlinear Dynamics.](#)
- [SU\(2\) and SU\(1,1\) interferometers.](#)
- [Spin-Mixing Interferometry with Bose-Einstein Condensates.](#)
- [Quantum metrology with parametric amplifier-based photon correlation interferometers](#)
- [Statistical distance and the geometry of quantum states](#)

Share this paper:    

View more about this paper here: <https://typeset.io/papers/pumped-up-su-1-1-interferometry-4p7btmq3o>

Pumped-Up SU(1,1) Interferometry

Stuart S. Szigeti,^{1,2} Robert J. Lewis-Swan,¹ and Simon A. Haine³

¹*School of Mathematics and Physics, University of Queensland, Brisbane, Queensland 4072, Australia*

²*ARC Centre of Excellence for Engineered Quantum Systems, University of Queensland, Brisbane, Queensland 4072, Australia*

³*Department of Physics and Astronomy, University of Sussex, Brighton BN1 9QH, United Kingdom*

(Received 24 October 2016; revised manuscript received 15 January 2017; published 11 April 2017)

Although SU(1,1) interferometry achieves Heisenberg-limited sensitivities, it suffers from one major drawback: Only those particles outcoupled from the pump mode contribute to the phase measurement. Since the number of particles outcoupled to these “side modes” is typically small, this limits the interferometer’s *absolute* sensitivity. We propose an alternative “pumped-up” approach where all the input particles participate in the phase measurement and show how this can be implemented in spinor Bose-Einstein condensates and hybrid atom-light systems—both of which have experimentally realized SU(1,1) interferometry. We demonstrate that pumped-up schemes are capable of surpassing the shot-noise limit with respect to the total number of input particles and are never worse than conventional SU(1,1) interferometry. Finally, we show that pumped-up schemes continue to excel—both absolutely and in comparison to conventional SU(1,1) interferometry—in the presence of particle losses, poor particle-resolution detection, and noise on the relative phase difference between the two side modes. Pumped-up SU(1,1) interferometry therefore pushes the advantages of conventional SU(1,1) interferometry into the regime of high absolute sensitivity, which is a necessary condition for useful quantum-enhanced devices.

DOI: 10.1103/PhysRevLett.118.150401

Quantum correlations allow precision interferometric measurements below the shot-noise limit [1,2]. This can be achieved by replacing the input state of a conventional interferometer with a nonclassical state; this is the approach being pursued in gravitational wave detection [3,4], where the vacuum port of a Michelson interferometer is substituted for a squeezed-light source. Unfortunately, the fragility of highly correlated quantum states to detection losses severely limits the quantum enhancement achievable in practice [5]. An alternative approach is to design an interferometer where the quantum correlations are generated within the interferometer, thereby making it robust to these losses. The archetypical example is a SU(1,1) interferometer [6,7], which is configured as a Mach-Zehnder with the passive beam splitters replaced by *active* nonlinear beam splitters that create or annihilate pairs of correlated particles [see Fig. 1(a)]. This generates a high degree of particle entanglement *within* the interferometer, allowing phase measurements at the ultimate Heisenberg limit while additionally providing a robustness to inefficient particle detection [8,9]. This excellent “per particle” sensitivity and robustness has resulted in a strong theoretical interest in SU(1,1) interferometry [10–13] and its experimental realization in optical systems [14,15], hybrid atom-light interferometers [16], and spinor Bose-Einstein condensates (BECs) [17–19].

Unfortunately, the prospect of a *high-precision* SU(1,1) interferometer is limited. In practice, it is difficult to engineer nonlinear active beam splitters that are both reversible and capable of outcoupling even modest numbers of particles. For example, the Heisenberg-limited phase measurement reported

in Ref. [19] was made with a mere 2.8 ± 0.2 particles on average. Consequently, the promise of Heisenberg-limited sensitivities is of little practical benefit, especially when sophisticated *classical* interferometers display superior absolute sensitivities by many orders of magnitude and suffer none of the robustness issues that afflict quantum-enhanced devices. The crux of the issue is that SU(1,1) interferometry is inherently wasteful; it requires the generation and manipulation of large numbers of particles but does not make use of all these particles within the phase measurement. As a general heuristic, a necessary condition for a high-precision (i.e., *useful*) quantum-enhanced device is that the quantum enhancement provide additional sensitivity beyond the shot-noise limit with respect to the *total* particle number.

In this Letter, we present a modification to SU(1,1) interferometry that (a) uses *all* particles to make the phase measurement, (b) gives sub-shot-noise sensitivities with respect to the total particle number, and (c) is surprisingly more robust than conventional SU(1,1) interferometry to inefficient particle detection. Our “pumped-up” approach linearly mixes the correlated pairs of particles with the pump mode(s) from which these particles are outcoupled and, therefore, represents only a small increase in the complexity of the interferometer design. Nevertheless, pumped-up SU(1,1) interferometry is, in principle, never worse than conventional SU(1,1) interferometry and is usually orders of magnitude more sensitive, even in the presence of typical losses. We illustrate the general principles of pumped-up SU(1,1) interferometry by considering specific implementations in (i) spinor BECs and (ii) hybrid

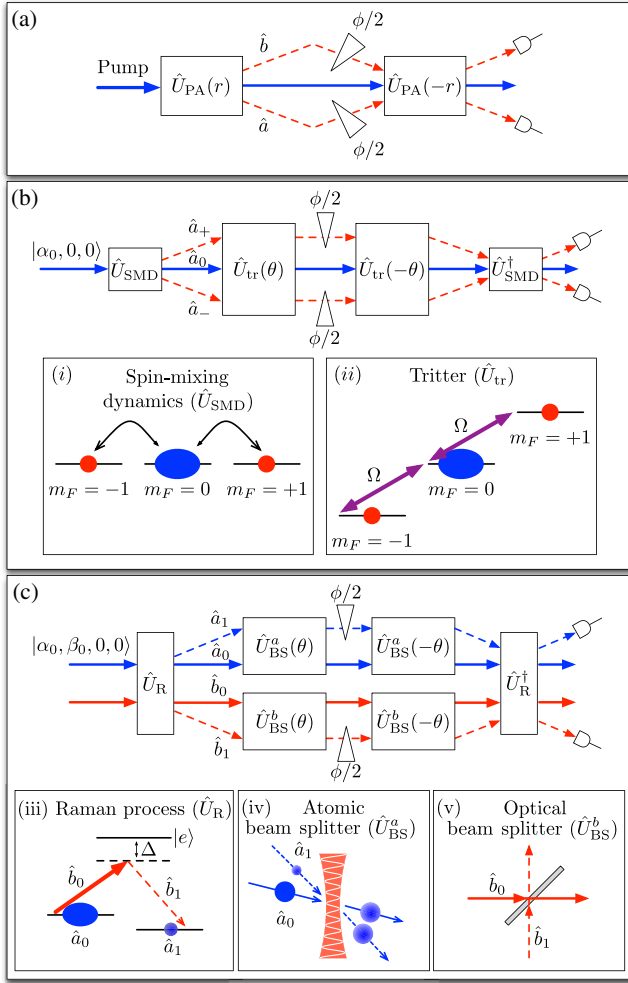

FIG. 1. (a) A conventional SU(1,1) interferometer, constructed with two active nonlinear beam splitters $\hat{U}_{\text{PA}}(r)$. (b) Pumped-up SU(1,1) interferometry with three modes of a spinor BEC. Initially, all atoms are in the $m_F = 0$ pump mode, assumed to be a coherent state $|\alpha_0\rangle$ with $|\alpha_0|^2 = \bar{N}$. The active beam splitter \hat{U}_{SMD} is achieved via spin-mixing collisions between three hyperfine levels [see (i) and Eq. (2)], whereas the pump is mixed with the two side modes using a tritter $\hat{U}_{\text{tr}}(\theta)$, engineered with coherent radio frequency pulses [see (ii) and Eq. (5)]. (c) Pumped-up SU(1,1) interferometry with the four modes of a hybrid atom-light system. The initial pump modes are coherent states, the active beam splitter $\hat{U}_{\text{R}}(r)$ is realized by FWM engineered with a Raman process [see (iii) and Eq. (3)], and pump enhancement is achieved with atomic and optical beam splitters that separately mix the atomic and photonic modes [see (iv) and (v), respectively].

atom-light systems. Both platforms have experimentally realized proof-of-principle SU(1,1) interferometry [16,19] and, therefore, represent strong candidate systems for implementing our pumped-up approach.

Conventional SU(1,1) interferometry.—The first beam splitter in a SU(1,1) interferometer actively creates correlated particle pairs via parametric amplification, described by the unitary $\hat{U}_{\text{PA}}(r) = \exp[-ir(\hat{a}_1^\dagger \hat{a}_2^\dagger + \hat{a}_1 \hat{a}_2)]$, where \hat{a}_1

and \hat{a}_2 are the two bosonic modes that form the arms of the interferometer (the “side modes”). Since these modes are initially vacuum, this unitary produces a two-mode squeezed vacuum state—which is a coherent superposition of twin-Fock states—with average particle number $\mathcal{N}_s \equiv 2 \sinh^2 r$ [20]. These particles are assumed to be outcoupled from an undepleted reservoir (the “pump mode”), whose average occupation is much larger than \mathcal{N}_s . After some interrogation time, which imprints a phase $\phi/2$ on each side mode, a second parametric amplifier reverses the first [see Fig. 1(a)]; this is conveniently achieved by imposing a $\pi/2$ phase shift on the pump such that $r \rightarrow -r$. A measurement of the number sum of the two side modes $\hat{N}_s = \hat{a}_1^\dagger \hat{a}_1 + \hat{a}_2^\dagger \hat{a}_2$ at the output is sensitive to the phase ϕ . Explicitly, at the optimal operating point $\phi = 0$, the phase sensitivity of this measurement is Heisenberg limited with respect to \mathcal{N}_s :

$$\Delta\phi_{\text{SU}(1,1)} = \frac{\sqrt{\text{Var}(\hat{N}_s)}}{|\partial\langle\hat{N}_s\rangle/\partial\phi|_{\phi=0}} = \frac{1}{\sqrt{\mathcal{N}_s(\mathcal{N}_s + 2)}}. \quad (1)$$

We consider two physical systems which have experimentally realized SU(1,1) interferometry.

(i) *Spinor BEC.*—The hyperfine manifold of a spin-1 BEC of ultracold atoms can be used to construct an effective three-level system. Spin-mixing collisions coherently outcouple pairs of atoms from the $m_F = 0$ state (pump mode \hat{a}_0) to the $m_F = \pm 1$ states (side modes \hat{a}_\pm) [see Fig. 1(i)]. The full spin-mixing dynamics are given by [21,22]

$$\begin{aligned} \hat{H}_{\text{SMD}} = & \hbar\kappa[\hat{a}_0^2 \hat{a}_+^\dagger \hat{a}_-^\dagger + (\hat{a}_0^\dagger)^2 \hat{a}_+ \hat{a}_-] \\ & + \hbar\kappa\left(\hat{N}_0 - \frac{1}{2}\right)(\hat{N}_+ + \hat{N}_-) + \hbar q(\hat{N}_+ + \hat{N}_-), \end{aligned} \quad (2)$$

where $\hat{N}_i \equiv \hat{a}_i^\dagger \hat{a}_i$. By dynamically tuning q with a magnetic field, the quadratic Zeeman shift (third term) cancels collisional shifts due to s -wave scattering of the three modes (second term) [19,23]. Then, provided $\langle\hat{N}_0\rangle \gg \langle\hat{N}_\pm\rangle$ throughout the interaction time t , the undepleted pump approximation $\hat{a}_0 \rightarrow \sqrt{\bar{N}}$ holds (for average total particle number \bar{N}), and we realize $\hat{U}_{\text{PA}}(r)$ with $r = \bar{N}\kappa t$.

(ii) *Hybrid atom-light system.*—Four-wave mixing (FWM) via a Raman pulse generates atom-light entanglement. For an atomic ensemble prepared in pump mode \hat{a}_0 , a coherent optical pump beam \hat{b}_0 transfers atoms from the pump to another atomic mode \hat{a}_1 , accompanied by the emission of a photon \hat{b}_1 [see Fig. 1(iii)]. Since outcoupling one atom correlates with the production of one photon, this realizes correlated atom-light pairs according to [24–27]

$$\hat{H}_{\text{FWM}} = \hbar\kappa(\hat{a}_0^\dagger \hat{b}_0^\dagger \hat{a}_1 \hat{b}_1 + \hat{a}_0 \hat{b}_0 \hat{a}_1^\dagger \hat{b}_1^\dagger). \quad (3)$$

If both pump modes \hat{a}_0 and \hat{b}_0 remain highly occupied compared with the side modes \hat{a}_1 and \hat{b}_1 , then the

undepleted pump approximation holds ($\hat{a}_0 \rightarrow \sqrt{N_{a_0}}$ and $\hat{b}_0 \rightarrow \sqrt{N_{b_0}}$ if both pumps are in phase), and we realize $\hat{U}_{\text{PA}}(r)$ with $r = \sqrt{N_{a_0}N_{b_0}}kt$.

Pumped-up SU(1,1) interferometry with spinor BECs.— We aim to boost the absolute sensitivity of the interferometer by linearly mixing the pump mode \hat{a}_0 with side modes \hat{a}_{\pm} after the first nonlinear beam splitter described by Eq. (2). We do this via a variable-angle three-mode beam splitter (i.e., *tritter*):

$$\hat{H}_{\text{tr}} = \frac{\hbar\Omega}{\sqrt{2}} [e^{i\vartheta}\hat{a}_0^\dagger(\hat{a}_+ + \hat{a}_-) + e^{-i\vartheta}\hat{a}_0(\hat{a}_+^\dagger + \hat{a}_-^\dagger)], \quad (4)$$

which evolves the modes according to

$$\hat{a}_{\pm}(\theta) = \hat{a}_{\pm}\cos^2\left(\frac{\theta}{2}\right) - \hat{a}_{\mp}\sin^2\left(\frac{\theta}{2}\right) - \frac{ie^{-i\vartheta}}{\sqrt{2}}\hat{a}_0\sin\theta, \quad (5a)$$

$$\hat{a}_0(\theta) = \hat{a}_0\cos\theta - \frac{ie^{i\vartheta}}{\sqrt{2}}(\hat{a}_+ + \hat{a}_-)\sin\theta, \quad (5b)$$

where $\theta = \Omega t$ and ϑ are the tritter angle and phase, respectively. A tritter is achieved by coherently coupling the $m_F = 0$ state to the $m_F = \pm 1$ states via a radio frequency pulse of Rabi frequency Ω and phase ϑ , as illustrated in Fig. 1(ii). This can be done with high fidelity and on time scales much faster than the nonlinear outcoupling process or phase evolution, as demonstrated experimentally in Ref. [28]. After the first tritter, we assume a period of phase evolution that writes a phase $\phi/2$ onto each side mode; the interferometer is then closed by implementing a second tritter (with $\theta \rightarrow -\theta$, achievable by changing $\vartheta \rightarrow \vartheta + \pi$) and a second period of spin mixing [see Fig. 1(b)].

We first quantify the effect of pump enhancement via the quantum Fisher information (QFI), which places a lower bound on the achievable sensitivity $\Delta\phi \geq 1/\sqrt{\mathcal{F}}$ called the quantum Cramér-Rao bound (QCRB) [2,29,30]. This bound holds irrespective of the specific measurement signal at the output and phase-estimation procedure; here it is entirely determined by the input state, the dynamics of the first spin-mixing operation, and the first tritter (via the angle θ and phase ϑ). Specifically, within the undepleted pump regime, the QFI is [31–41]

$$\mathcal{F}(\theta) = \bar{N}\sin^2\theta + \frac{1}{4}(\bar{N} - \mathcal{N}_s)\mathcal{G}(\mathcal{N}_s, \vartheta)\sin^2(2\theta) + \frac{1}{2}\mathcal{N}_s\{\mathcal{N}_s + [3 + (\mathcal{N}_s + 1)\cos^2\theta]\cos^2\theta\}, \quad (6)$$

where $\mathcal{G}(\mathcal{N}_s, \vartheta) \equiv \mathcal{N}_s - \sqrt{\mathcal{N}_s(\mathcal{N}_s + 2)}\sin(2\vartheta)$. For $\theta = 0$ we recover conventional SU(1,1) interferometry with QFI $\mathcal{F}(0) = \mathcal{N}_s(\mathcal{N}_s + 2)$. Indeed, it trivially follows that $\max_{\theta}\mathcal{F}(\theta) \geq \mathcal{F}(0)$, proving that with arbitrary control over θ pump enhancement gives sensitivities no worse than conventional SU(1,1) interferometry—and, as we will demonstrate, usually much better in practice.

Maximizing Eq. (6) yields optimal parameters $\vartheta_{\text{opt}} = 3\pi/2$ and $\theta_{\text{opt}} = 0, \pi/2$, or $\{\pi + 2\text{csc}^{-1}[\mathcal{G}(\mathcal{N}_s, \vartheta)]\}/4 + \mathcal{O}(1/\bar{N})$, and to leading order in \bar{N}

$$\mathcal{F}(\theta_{\text{opt}}) = \begin{cases} \bar{N} + \frac{1}{2}\mathcal{N}_s^2, & \mathcal{N}_s < \frac{1}{4}, \\ \max\left\{\frac{e^{2r(1+\coth r)}}{8}\bar{N}, \mathcal{F}(0)\right\}, & \mathcal{N}_s \geq \frac{1}{4}. \end{cases} \quad (7)$$

Therefore, pumped-up SU(1,1) interferometry has an achievable sensitivity at least as good as the shot-noise limit (with respect to total particle number \bar{N}), and any quantum enhancement improves the sensitivity *beyond* this shot-noise limit. Conventional SU(1,1) is beneficial only when \mathcal{N}_s is of the same order as \bar{N} , well outside both the undepleted pump regime and current experimental capabilities. Figure 2(a) graphically compares our pumped-up scheme with conventional SU(1,1) interferometry; this includes analytic undepleted pump expressions and numerical truncated Wigner simulations [42–44] where \hat{a}_0 is treated as a quantum degree of freedom, thereby incorporating the effect of pump depletion [31].

It was recently shown that the Loschmidt echo protocol saturates the QCRB [32]. In this protocol, the dynamics that evolved the initial state to the state with QFI \mathcal{F} are reversed, and a measurement that projects the final state onto the initial state is made. For our scheme, this reversal corresponds to the second tritter and second spin-mixing step, followed by a measurement signal $\hat{\mathcal{S}}_{\text{LE}} = |\alpha_0, 0, 0\rangle\langle\alpha_0, 0, 0|$. However, in practice, superselection rules forbid measurements that project onto this initial pump coherent state; if instead we ignore the pump and choose a measurement signal $\hat{\mathcal{S}}'_{\text{LE}} = |0, 0\rangle\langle 0, 0| = \sum_N |N, 0, 0\rangle\langle N, 0, 0|$, we obtain the *suboptimal* sensitivity $\Delta\phi = 1/\sqrt{\mathcal{F}(\theta) - \bar{N}\sin^4\theta}$ [31].

An operationally more convenient approach is to measure the number sum of the side modes at the outputs [as done in conventional SU(1,1) interferometry]. Although suboptimal, this phase measurement is more robust to inefficient detection than a Loschmidt echo [46] and within the undepleted pump regime gives a phase sensitivity [31]

$$\Delta\phi_N = \frac{\sqrt{\text{Var}(\hat{N}_s)}}{|\partial\langle\hat{N}_s\rangle/\partial\phi|_{\phi=0}} = \frac{2|\text{csc}(2\theta)|}{\sqrt{\eta(r)\bar{N}}} + \mathcal{O}(1/\bar{N}^{3/2}), \quad (8)$$

where $\eta(r) \equiv \cosh(2r) - \sin(2\theta)\sinh(2r)$. Optimal parameters $\vartheta_{\text{opt}} = 3\pi/2$ and $\theta_{\text{opt}} = \pi/4$ give minimum sensitivity $\Delta\phi_N \approx 2\exp(-r)/\sqrt{\bar{N}}$. As confirmed in Fig. 1(b), this is never more than a factor of 2 larger than the QCRB and saturates this bound for $\mathcal{N}_s \gtrsim 2$.

Hybrid atom-light pumped-up SU(1,1) interferometry.— As shown in Fig. 1(c), the atomic and photonic pumps are mixed with their respective side modes via a variable angle two-mode beam splitter: $\hat{U}_{\text{BS}}^a(\theta) = \exp[-i\theta(e^{-i\vartheta}\hat{a}_0\hat{a}_1^\dagger + \text{H.c.})]$ and similarly for $\hat{U}_{\text{BS}}^b(\theta)$ [see Figs. 1(iv) and 1(v)].

The atomic modes are coupled via coherent light pulses commonly employed in atom interferometers [47]. For simplicity, we assume the atomic and photonic beam splitters have identical angle θ and phase ϑ . As shown in Fig. 2(b), pumped-up SU(1,1) interferometry within a hybrid atom-light system has qualitative similarities to the spinor BEC case and therefore possesses all the same advantages over conventional SU(1,1) interferometry. One subtle difference is that the overall enhancement depends on both the total particle number \bar{N} (atoms + photons) and the fraction of initial pump atoms to pump photons, n_f . Specifically, to leading order in \bar{N} , the maximum QFI and minimum phase sensitivity for a number-sum measurement are [31]

$$\mathcal{F}(\theta_{\text{opt}}) = \begin{cases} \bar{N} - \mathcal{N}_s, & \mathcal{N}_s < \frac{1}{4}, \\ \max \left\{ \frac{[\eta(r, n_f)]^2}{4[\eta(r, n_f) - 1]} \bar{N}, \mathcal{F}(0) \right\}, & \mathcal{N}_s \geq \frac{1}{4}, \end{cases} \quad (9)$$

$$\Delta\phi_N = 2/\sqrt{\eta(r, n_f)\bar{N}}, \quad (10)$$

where $\eta(n_f) \equiv \cosh(2r) + [2\sqrt{n_f}/(1+n_f)] \sinh(2r)$ and $\vartheta_{\text{opt}} = 3\pi/4$. For fixed \bar{N} , the optimal regime is $n_f = 1$, giving identical expressions to the spinor BEC case. More generally, there are likely to be considerably more photons than atoms ($n_f < 1$); since photons are “cheap” compared with atoms (in the sense that there are more severe particle-flux constraints on atoms than photons [48,49]), a large absolute sensitivity could be obtained by increasing the number of pump photons (i.e., increasing \bar{N}) while simultaneously decreasing n_f (therefore decreasing the per particle sensitivity), in the spirit of information recycling protocols [26,27,50–53].

Effect of losses.—Finally, we compare the performance of both pumped-up schemes to conventional SU(1,1) interferometry under the following three experimental sources of loss.

(i) *Particle loss.*—During spin-mixing dynamics of a spinor condensate, particle loss is primarily caused by two-body recombination between atoms [54–56], while for FWM within the hybrid atom-light system, one-body particle losses are due to the spontaneous scattering of atoms and photons [24]. Two-body losses during the spin-mixing dynamics are modeled with the master equation $\partial_t \hat{\rho} = -(i/\hbar)[\hat{H}_{\text{SMD}}, \hat{\rho}] + \sum_{i,j=0,\pm} \gamma_{i,j} \mathcal{D}[\hat{a}_i \hat{a}_j] \hat{\rho}$ and one-body losses from the pumps during FWM with $\partial_t \hat{\rho} = -(i/\hbar)[\hat{H}_{\text{FWM}}, \hat{\rho}] + (\gamma_{a_0} \mathcal{D}[\hat{a}_0] + \gamma_{b_0} \mathcal{D}[\hat{b}_0]) \hat{\rho}$, where $\mathcal{D}[\hat{L}] \hat{\rho} \equiv \hat{L} \hat{\rho} \hat{L}^\dagger - \frac{1}{2} \{ \hat{L}^\dagger \hat{L}, \hat{\rho} \}$ and $\gamma_{i,j}$, γ_{a_0} , and γ_{b_0} are loss rates. Since two-body loss is strongly number dependent, within the undepleted pump regime, losses predominantly occur from the pump mode. Consequently, the precise value of loss rates involving collisions with \hat{a}_\pm atoms relative to $\gamma_{0,0}$ is unimportant, so for simplicity we set $\gamma_{i,j} = \gamma$. We numerically solved these master equations and computed the phase sensitivity under the effect of these losses via the

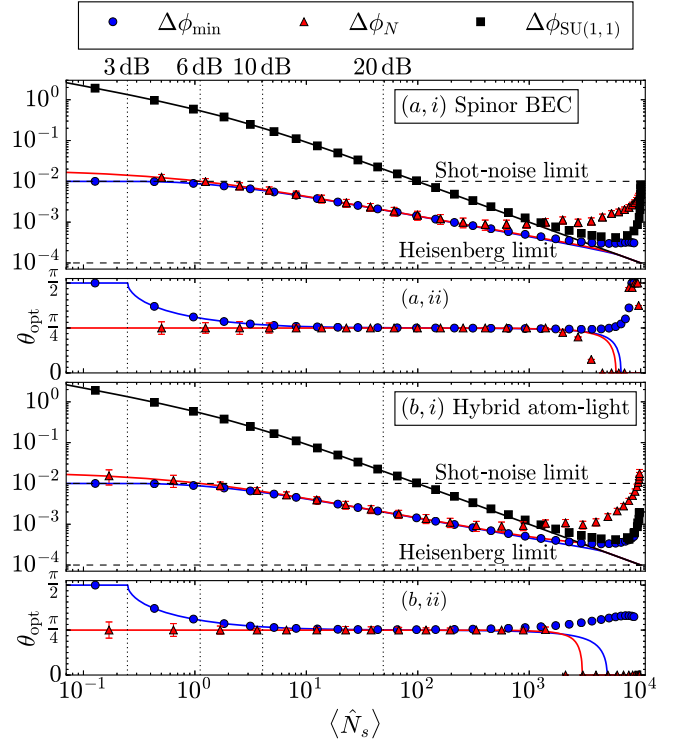

FIG. 2. Comparison of pumped-up and conventional SU(1,1) interferometry, engineered within (a) a spinor BEC and (b) a hybrid atom-light system (with $n_f = 1$). The total particle number is $\bar{N} = 10^4$. Sensitivities are plotted in (i), while optimal tritter (or beam splitter) angles θ_{opt} for pumped-up interferometry are shown in (ii). For our pumped-up schemes, $\Delta\phi_{\text{min}} = 1/\sqrt{\mathcal{F}(\theta_{\text{opt}})}$ is the QCRB, and $(\Delta\phi_N)^2 = \min_{\theta,\phi} \text{Var}(\hat{N}_s)/|\partial\langle\hat{N}_s\rangle/\partial\phi|^2$ gives the phase sensitivity for a number-sum measurement of the two side modes at the output; these are plotted for ϑ_{opt} . $\Delta\phi_{\text{SU}(1,1)} = 1/\sqrt{\mathcal{F}(0)}$ is the QCRB for conventional SU(1,1) interferometry, only saturated by a number-sum measurement of the side modes within the undepleted pump regime. Solid lines are analytic curves obtained in the undepleted pump regime (accurate to all orders of \bar{N} —see [31] for exact expressions), whereas markers are truncated Wigner simulations which include the effects of pump depletion [45]. The four vertical lines indicate the degree of squeezing associated with four values of $\langle\hat{N}_s\rangle$; these mark experimentally accessible regimes ranging from currently achievable (3 dB) to extremely challenging (20 dB).

truncated Wigner simulation method [31]. As shown in the left panel in Fig. 3, these types of particle loss affect pumped-up and conventional SU(1,1) interferometry similarly; consequently, our pumped-up approach maintains its considerable advantage.

(ii) *Imperfect particle detection.*—We model imperfect detection resolution as a Gaussian noise of variance $(\Delta n)^2$, which corresponds to an uncertainty Δn in the particle number measured at the output. This technical noise increases the quantum noise on the signal, modifying the phase sensitivity: $(\Delta\phi_N)^2 = [\text{Var}(\hat{N}_s) + (\Delta n)^2]/(\partial_\phi\langle\hat{N}_s\rangle)^2$ [57]. In general, this modifies the optimal operating point;

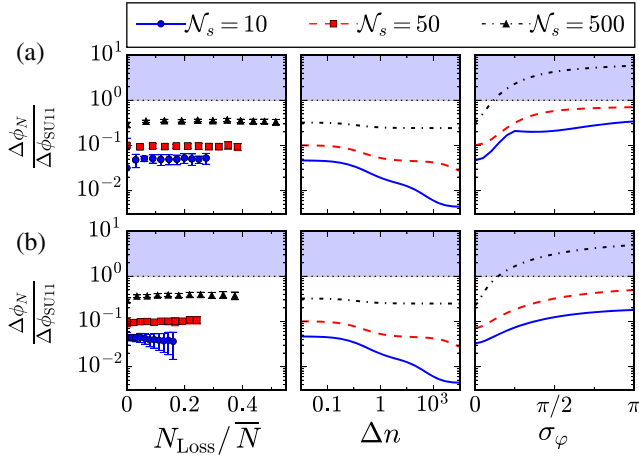

FIG. 3. Relative sensitivities of pumped-up SU(1,1) interferometry compared with conventional SU(1,1) interferometry in (a) a spinor BEC setup [top panels] and (b) a hybrid atom-light system (with $n_f = 1$) [bottom panels]. The total particle number is $\bar{N} = 10^4$. All values plotted are at optimal ϕ and, for pumped-up schemes, optimal angle θ_{opt} and phase ϕ_{opt} . These show the dependence on (left) the fraction of particles lost due to (a) two-body and (b) one-body losses, obtained via truncated Wigner simulations; (middle) imperfect particle detection with number resolution Δn , obtained from semianalytic calculations [31]; and (right) Gaussian phase-difference noise of variance σ_ϕ^2 , obtained from analytic calculations with ϕ optimized numerically. Pumped-up SU(1,1) interferometry is superior to conventional SU(1,1) interferometry for those points or curves outside the shaded region. The side-mode populations $\mathcal{N}_s = 10, 50$, and 500 correspond to approximately 13.4, 20, and 30 dB of squeezing, respectively. *Absolute* sensitivities $\Delta\phi_N$ under losses are plotted in Supplemental Material [31].

however, provided $\Delta n \lesssim \bar{N}$, the sensitivity of pumped-up SU(1,1) interferometry is *independent* of imperfect particle detection [31]. This is a further advantage of pumped-up interferometry over conventional SU(1,1) interferometry. Furthermore, this robustness and superior performance is maintained for $\Delta n > \bar{N}$ [see the middle panel in Fig. 3].

(iii) *Phase difference noise.*—In contrast to conventional SU(1,1) interferometry, our pumped-up schemes are sensitive to both the phase sum ϕ and the phase *difference* ϕ between both arms of the interferometer. If an experiment cannot perfectly control ϕ from shot to shot (e.g., energy shifts in spinor BECs due to the linear Zeeman effect), this degrades the sensitivity. We study the effect of this noise by assuming ϕ is a Gaussian noise with variance σ_ϕ^2 . As shown in the right panel in Fig. 3, this degrades the sensitivity of pumped-up schemes compared with conventional SU(1,1) interferometry, particularly for larger values of quantum enhancement. Nevertheless, for the moderate levels of quantum enhancement achievable in practice, pumped-up SU(1,1) interferometry still surpasses conventional SU(1,1) interferometry between a factor of 2 and 10—even for large σ_ϕ . Furthermore, the experimental results of Ref. [28]

suggest that noise due to ϕ can be minimized in spinor BEC interferometers.

Conclusions.—We have shown that pumped-up SU(1,1) interferometry considerably outperforms conventional SU(1,1) interferometry, even when typical experimental losses are included. Importantly, we illustrated the viability of pump enhancement in both spinor BECs and hybrid atom-light systems—which have both realized proof-of-principle conventional SU(1,1) interferometry and are therefore capable of realizing our pumped-up schemes in the near term. Pumped-up SU(1,1) interferometry therefore pushes the advantages of conventional SU(1,1) interferometry into the regime of high absolute sensitivity, a necessary condition for useful quantum-enhanced devices.

We acknowledge useful discussions with Carlton Caves, Joel Corney, Daniel Linnemann, and Sam Nolan. Numerical simulations were performed using XMDS2 [58] on the University of Queensland School of Mathematics and Physics computing cluster “Obelix,” with thanks to I. Mortimer for computing support. This project was supported by Australian Research Council (ARC) Projects No. DE130100575 and No. DP140101763 and has received funding from the European Union’s Horizon 2020 research and innovation program under the Marie Skłodowska-Curie Grant Agreement No. 704672. S. S. S. acknowledges the support of the ARC Centre of Excellence for Engineered Quantum Systems (Project No. CE110001013).

- [1] C. M. Caves, Quantum-mechanical noise in an interferometer, *Phys. Rev. D* **23**, 1693 (1981).
- [2] G. Tóth and I. Apellaniz, Quantum metrology from a quantum information science perspective, *J. Phys. A* **47**, 424006 (2014).
- [3] LIGO Scientific Collaboration, A gravitational wave observatory operating beyond the quantum shot-noise limit, *Nat. Phys.* **7**, 962 (2011).
- [4] LIGO Scientific Collaboration, Enhanced sensitivity of the LIGO gravitational wave detector by using squeezed states of light, *Nat. Photonics* **7**, 613 (2013).
- [5] R. Demkowicz-Dobrzanski, J. Kolodynski, and M. Guta, The elusive Heisenberg limit in quantum-enhanced metrology, *Nat. Commun.* **3**, 1063 (2012).
- [6] B. Yurke, S.L. McCall, and J.R. Klauder, SU(2) and SU(1,1) interferometers, *Phys. Rev. A* **33**, 4033 (1986).
- [7] U. Leonhardt, Quantum statistics of a two-mode SU(1,1) interferometer, *Phys. Rev. A* **49**, 1231 (1994).
- [8] A. M. Marino, N. V. Corzo Trejo, and P. D. Lett, Effect of losses on the performance of an SU(1,1) interferometer, *Phys. Rev. A* **86**, 023844 (2012).
- [9] Z. Y. Ou, Enhancement of the phase-measurement sensitivity beyond the standard quantum limit by a nonlinear interferometer, *Phys. Rev. A* **85**, 023815 (2012).
- [10] M. Gabbriellini, L. Pezzè, and A. Smerzi, Spin-Mixing Interferometry with Bose-Einstein Condensates, *Phys. Rev. Lett.* **115**, 163002 (2015).

- [11] Z.-D. Chen, C.-H. Yuan, H.-M. Ma, D. Li, L. Q. Chen, Z. Y. Ou, and W. Zhang, Effects of losses in the atom-light hybrid SU(1,1) interferometer, *Opt. Express* **24**, 17766 (2016).
- [12] Q.-K. Gong, D. Li, C.-H. Yuan, Z. Y. Ou, and W. Zhang, Bounds to precision for an SU(1,1) interferometer with Gaussian input states, [arXiv:1608.00389v2](https://arxiv.org/abs/1608.00389v2).
- [13] J. Xin, H. Wang, and J. Jing, The effect of losses on the quantum-noise cancellation in the SU(1,1) interferometer, *Appl. Phys. Lett.* **109**, 051107 (2016).
- [14] J. Jing, C. Liu, Z. Zhou, Z. Y. Ou, and W. Zhang, Realization of a nonlinear interferometer with parametric amplifiers, *Appl. Phys. Lett.* **99**, 011110 (2011).
- [15] F. Hudelist, J. Kong, C. Liu, J. Jing, Z. Y. Ou, and W. Zhang, Quantum metrology with parametric amplifier-based photon correlation interferometers, *Nat. Commun.* **5**, 3049 (2014).
- [16] B. Chen, C. Qiu, S. Chen, J. Guo, L. Q. Chen, Z. Y. Ou, and W. Zhang, Atom-Light Hybrid Interferometer, *Phys. Rev. Lett.* **115**, 043602 (2015).
- [17] C. Gross, T. Zibold, E. Nicklas, J. Estève, and M. K. Oberthaler, Nonlinear atom interferometer surpasses classical precision limit, *Nature (London)* **464**, 1165 (2010).
- [18] J. Peise, B. Lücke, L. Pezzé, F. Deuretzbacher, W. Ertmer, J. Arlt, A. Smerzi, L. Santos, and C. Klempt, Interaction-free measurements by quantum Zeno stabilization of ultracold atoms, *Nat. Commun.* **6**, 6811 (2015).
- [19] D. Linnemann, H. Strobel, W. Muessel, J. Schulz, R. J. Lewis-Swan, K. V. Kheruntsyan, and M. K. Oberthaler, Quantum-Enhanced Sensing Based on Time Reversal of Nonlinear Dynamics, *Phys. Rev. Lett.* **117**, 013001 (2016).
- [20] R. Loudon and P. L. Knight, Squeezed light, *J. Mod. Opt.* **34**, 709 (1987).
- [21] C. K. Law, H. Pu, and N. P. Bigelow, Quantum Spins Mixing in Spinor Bose-Einstein Condensates, *Phys. Rev. Lett.* **81**, 5257 (1998).
- [22] R. J. Lewis-Swan and K. V. Kheruntsyan, Sensitivity to thermal noise of atomic Einstein-Podolsky-Rosen entanglement, *Phys. Rev. A* **87**, 063635 (2013).
- [23] In the undepleted pump regime, $q(t) = \kappa(\langle \hat{N}_0 \rangle - 1/2)$ suffices.
- [24] M. G. Moore and P. Meystre, Generating Entangled Atom-Photon Pairs from Bose-Einstein Condensates, *Phys. Rev. Lett.* **85**, 5026 (2000).
- [25] K. Hammerer, A. S. Sørensen, and E. S. Polzik, Quantum interface between light and atomic ensembles, *Rev. Mod. Phys.* **82**, 1041 (2010).
- [26] S. A. Haine, Information-Recycling Beam Splitters for Quantum Enhanced Atom Interferometry, *Phys. Rev. Lett.* **110**, 053002 (2013).
- [27] S. A. Haine and Wing Yung Sarah Lau, Generation of atom-light entanglement in an optical cavity for quantum enhanced atom interferometry, *Phys. Rev. A* **93**, 023607 (2016).
- [28] I. Kruse, K. Lange, J. Peise, B. Lücke, L. Pezzé, J. Arlt, W. Ertmer, C. Lisdat, L. Santos, A. Smerzi, and C. Klempt, Improvement of an Atomic Clock using Squeezed Vacuum, *Phys. Rev. Lett.* **117**, 143004 (2016).
- [29] S. L. Braunstein and C. M. Caves, Statistical Distance and the Geometry of Quantum States, *Phys. Rev. Lett.* **72**, 3439 (1994).
- [30] R. Demkowicz-Dobrzański, M. Jarzyna, J. Kołodyński, and E. Wolf, Chapter Four - Quantum Limits in Optical Interferometry, in *Progress in Optics* (Elsevier, New York, 2015), Vol. 60, pp. 345–435.
- [31] See Supplemental Material at <http://link.aps.org/supplemental/10.1103/PhysRevLett.118.150401>, which includes Refs [32–41], for detailed calculations of the quantum Fisher information and phase sensitivity of a number-sum measurement and a brief description of our truncated Wigner simulations.
- [32] T. Macrì, A. Smerzi, and L. Pezzè, Loschmidt echo for quantum metrology, *Phys. Rev. A* **94**, 010102 (2016).
- [33] M. J. Steel, M. K. Olsen, L. I. Plimak, P. D. Drummond, S. M. Tan, M. J. Collett, D. F. Walls, and R. Graham, Dynamical quantum noise in trapped Bose-Einstein condensates, *Phys. Rev. A* **58**, 4824 (1998).
- [34] P. B. Blakie, A. S. Bradley, M. J. Davis, R. J. Ballagh, and C. W. Gardiner, Dynamics and statistical mechanics of ultracold Bose gases using c-field techniques, *Adv. Phys.* **57**, 363 (2008).
- [35] A. Polkovnikov, Phase space representation of quantum dynamics, *Ann. Phys. (Amsterdam)* **325**, 1790 (2010).
- [36] B. Opanchuk and P. D. Drummond, Functional Wigner representation of quantum dynamics of Bose-Einstein condensate, *J. Math. Phys. (N.Y.)* **54**, 042107 (2013).
- [37] D. F. Walls and G. J. Milburn, *Quantum Optics*, 2nd ed. (Springer-Verlag, Berlin, 2008).
- [38] C. W. Gardiner and P. Zoller, *Quantum Noise: A Handbook of Markovian and Non-Markovian Quantum Stochastic Methods with Applications to Quantum Optics*, 3rd ed. (Springer, Berlin, 2004).
- [39] A. Sinatra, C. Lobo, and Y. Castin, The truncated Wigner method for Bose-condensed gases: limits of validity and applications, *J. Phys. B* **35**, 3599 (2002).
- [40] B. Opanchuk, M. Egorov, S. Hoffmann, A. I. Sidorov, and P. D. Drummond, Quantum noise in three-dimensional BEC interferometry, *Europhys. Lett.* **97**, 50003 (2012).
- [41] M. Olsen and A. Bradley, Numerical representation of quantum states in the positive-P and Wigner representations, *Opt. Commun.* **282**, 3924 (2009).
- [42] P. D. Drummond and A. D. Hardman, Simulation of Quantum Effects in Raman-Active Waveguides, *Europhys. Lett.* **21**, 279 (1993).
- [43] S. J. Carter, Quantum theory of nonlinear fiber optics: Phase-space representations, *Phys. Rev. A* **51**, 3274 (1995).
- [44] M. K. Olsen and M. J. Davis, Entanglement properties of degenerate four-wave mixing of matter waves in a periodic potential, *Phys. Rev. A* **73**, 063618 (2006).
- [45] For high depletion, $\text{Var}(\hat{N}_s) \sim \langle \hat{N}_s \rangle^2$ no longer holds, which reduces the QFI.
- [46] S. P. Nolan, S. S. Szigeti, and S. A. Haine, Optimal and Robust Quantum-Enhanced Metrology Without Echoes, [arXiv:1703.10417](https://arxiv.org/abs/1703.10417).
- [47] M. Kasevich and S. Chu, Measurement of the gravitational acceleration of an atom with a light-pulse atom interferometer, *Appl. Phys. B* **54**, 321 (1992).
- [48] S. S. Szigeti, J. E. Debs, J. J. Hope, N. P. Robins, and J. D. Close, Why momentum width matters for atom interferometry with Bragg pulses, *New J. Phys.* **14**, 023009 (2012).

- [49] N. P. Robins, P. A. Altin, J. E. Debs, and J. D. Close, Atom lasers: Production, properties and prospects for precision inertial measurement, *Phys. Rep.* **529**, 265 (2013).
- [50] S. S. Szigeti, B. Tonekaboni, Wing Yung S. Lau, S. N. Hood, and S. A. Haine, Squeezed-light-enhanced atom interferometry below the standard quantum limit, *Phys. Rev. A* **90**, 063630 (2014).
- [51] B. Tonekaboni, S. A. Haine, and S. S. Szigeti, Heisenberg-limited metrology with information recycling, *Phys. Rev. A* **91**, 033616 (2015).
- [52] S. A. Haine, S. S. Szigeti, M. D. Lang, and C. M. Caves, Heisenberg-limited metrology with information recycling, *Phys. Rev. A* **91**, 041802 (2015).
- [53] S. A. Haine and S. S. Szigeti, Quantum metrology with mixed states: When recovering lost information is better than never losing it, *Phys. Rev. A* **92**, 032317 (2015).
- [54] S. Tojo, T. Hayashi, T. Tanabe, T. Hirano, Y. Kawaguchi, H. Saito, and M. Ueda, Spin-dependent inelastic collisions in spin-2 Bose-Einstein condensates, *Phys. Rev. A* **80**, 042704 (2009).
- [55] B. Lücke, M. Scherer, J. Kruse, L. Pezzé, F. Deuretzbacher, P. Hyllus, O. Topic, J. Peise, W. Ertmer, J. Arlt, L. Santos, A. Smerzi, and C. Klempt, Twin matter waves for interferometry beyond the classical limit, *Science* **334**, 773 (2011).
- [56] C. Gross, H. Strobel, E. Nicklas, T. Zibold, N. Bar-Gill, G. Kurizki, and M. K. Oberthaler, Atomic homodyne detection of continuous-variable entangled twin-atom states, *Nature (London)* **480**, 219 (2011).
- [57] E. Davis, G. Bentsen, and M. Schleier-Smith, Approaching the Heisenberg Limit without Single-Particle Detection, *Phys. Rev. Lett.* **116**, 053601 (2016).
- [58] G. R. Dennis, J. J. Hope, and M. T. Johnsson, XMDS2: Fast, scalable simulation of coupled stochastic partial differential equations, *Comput. Phys. Commun.* **184**, 201 (2013).