

RADIO-CONTROLLED MODEL DESIGN AND TESTING TECHNIQUES
FOR STALL/SPIN EVALUATION OF GENERAL-AVIATION AIRCRAFT

Sanger M. Burk, Jr.

NASA Langley Research Center
Hampton, Virginia 23665

and

Calvin F. Wilson, Jr.

Piper Aircraft Corporation
Lock Haven, Pennsylvania 17745

Presented at the 1975 SAE National Business Aircraft Meeting

(NASA-TM-80510) RADIO-CONTROLLED MODEL
DESIGN AND TESTING TECHNIQUES FOR STALL/SPIN
EVALUATION OF GENERAL-AVIATION AIRCRAFT
(NASA) 63 p HC A04/MF A01

N79-30173

CSCI 01C

G3/05

Unclas
29095



Wichita, Kansas
April 8-11, 1975

RADIO-CONTROLLED MODEL DESIGN AND TESTING TECHNIQUES
FOR STALL/SPIN EVALUATION OF GENERAL-AVIATION AIRCRAFT

Sanger M. Burk, Jr.
NASA Langley Research Center
Hampton, Virginia 23665

and

Calvin F. Wilson, Jr.
Piper Aircraft Corporation
Lock Haven, Pennsylvania 17745

ABSTRACT

The paper discusses the research conducted at the NASA Langley Research Center to develop a relatively inexpensive radio-controlled model stall/spin test technique, and the operational experiences of the Piper Aircraft Corporation in utilizing the technique. Included is a discussion of model construction techniques, spin-recovery parachute system, data recording system, and movie camera tracking system. Also discussed are a method of measuring moments of inertia, scaling of engine thrust, cost and time required to conduct a program, and examples of the results obtained from the flight tests.

RADIO-CONTROLLED MODEL DESIGN AND TESTING TECHNIQUES
FOR STALL/SPIN EVALUATION OF GENERAL-AVIATION AIRCRAFT

Sanger M. Burk, Jr.
NASA Langley Research Center
Hampton, Virginia 23665

and

Calvin F. Wilson, Jr.
Piper Aircraft Corporation
Lock Haven, Pennsylvania 17745

INTRODUCTION

Two previous papers presented at past SAE Business Aircraft meetings discussed the NASA Stall/Spin Research Program and presented some spin-tunnel results (1,2)*. The present paper is a joint paper by the NASA Langley Research Center and the Piper Aircraft Corporation on the part of the program which deals with radio-controlled model testing for the evaluation of the stall/spin characteristics of general-aviation aircraft.

The radio-controlled model testing technique was developed by NASA to conduct research on spin entry, developed spin and spin recovery characteristics, including a definition of the proper size spin-recovery parachute and riser length, and to develop a low-cost radio-controlled model testing technique that general-aviation manufacturers could utilize to evaluate the stall/spin characteristics of airplanes during design.

The radio-controlled model testing technique was utilized by Piper to explore spin entry, developed spin, and recovery techniques of a light twin-engine airplane configuration. This testing technique was used because it

*Numbers in parentheses designate References at end of paper.

offered an effective, low-cost, low-risk technique for exploratory research on the spin characteristics of a particular airplane in the development stage.

This paper will discuss recent results obtained by both NASA and Piper with regard to the development and utilization of the radio-control model testing technique. Included in the paper are discussions of the model construction technique, a spin-recovery parachute system, a data recording system, a movie camera tracking system, a method of measuring moments of inertia, the scaling of the engine thrust, the cost and time required to conduct a program, and examples of the results obtained from the flight tests.

SYMBOLS

b	Wing span, ft
D	Distance between cables, ft
D_p	Propeller diameter, ft
F	Factor
g	Acceleration due to gravity, taken as 32.2 ft/sec ²
I	Moment of inertia about any body axis, slug-ft ²
$\frac{I_X - I_Y}{mb^2}$	Inertia yawing-moment parameter
J	Propeller advance ratio
k	Radius of gyration, inches
L	Length of cable, ft
l	Linear dimension, ft
m	Airplane or model mass, slugs
N	Scale factor (for example, N = 5 for a 1/5-scale model)
n	Engine speed, rev/sec
S	Wing area, ft ²

T	Engine thrust, lb
t	Time for one cycle, sec
TDR	Tail damping ratio
TDPF	Tail damping power factor
URVC	Unshielded rudder volume coefficient
V	Rate of descent, ft/sec
V_s	Stall speed, ft/sec
W	Weight, lb
ρ	Air density at spin altitude, slugs/ft ³
Ω	Rate of rotation about spin axis, rev/sec
μ	Relative density, $\frac{m}{\rho_{sb}}$

SUBSCRIPTS

A	Airplane
M	Model
X	X-body axis
Y	Y-body axis
Z	Z-body axis

SCALING OF DYNAMIC MODELS

In order to investigate the stall/spin characteristics of airplanes with free-flight models, the models must be both geometrically and dynamically scaled to represent the full-scale airplane. In brief, the scaling laws equate the nondimensional Froude number (ratio of inertial to gravitational forces) of the model to that of the airplane. In addition, the relative density, (μ) of the model must be scaled to represent the relative density of the airplane at altitude. As a result of such scaling, the spinning motion of the

model will be similar to that of the airplane. With this relationship, the angle of attack, wing tilt, spin rate, and rate of descent of an airplane can be predicted by conducting model tests. The formulas that define the proper scaling relationships between the airplane and model are as follows:

Length:
$$l_M = \frac{l_A}{N}$$

Area:
$$S_M = \frac{S_A}{N^2}$$

Weight:
$$W_M = \frac{W_A}{N^3} \frac{\rho_M}{\rho_A}$$

Moment of inertia:
$$I_M = \frac{I_A}{N^5} \frac{\rho_M}{\rho_A}$$

Velocity:
$$V_M = \frac{V_A}{\sqrt{N}}$$

Spin rate:
$$\Omega_M = \Omega_A \sqrt{N}$$

The effects of Reynolds number on the spin entry and developed spin characteristics of the model are not known. However, since the model passes through the stall portion of flight very quickly, typical Reynolds number effects at the stall (effects on lift) may not be significant to the spin entry and developed spin and recovery characteristics. Caution should be exercised, nevertheless, in interpreting the motions, since scale effects can be large at the stall, including large effects on lateral-directional characteristics. During the developed spin, it is expected that the scale effects would be small since the wing of the model is fully stalled. Future work at NASA will involve the evaluation of the Reynolds number effects on the spin entry and developed spin by conducting static force tests on models at both

low and high values of Reynolds number over a wide range of angles of attack from below the stall to well into the spinning range.

PART I

DEVELOPMENT OF TESTING TECHNIQUE

NATIONAL AERONAUTICS AND SPACE ADMINISTRATION

LANGLEY RESEARCH CENTER

DESIGN APPROACH

The approach used to determine the size model for use in the radio-control model program was to select a size that was large enough to make the remotely controlled handling qualities of the models acceptable for research flight testing, yet small enough to make possible use of existing hobby equipment such as transmitters, receivers, servos, and engines. The large distance between the model and pilot during the tests (generally 1000 feet, or more) makes the controllability of the model very critical. Since the angular velocities of dynamically scaled models vary as the square root of the scale factor, the angular motions of the model, for example, become much faster than those of the airplane as the model size decreases and thus the controllability of the model becomes much more difficult. On the other hand, the weight of the model is scaled by the cube of the scale factor, so a relatively large model would be very heavy, and would require engines much larger than conventional hobby engines. The choice of model size, therefore, is directly influenced by the engine size. After an examination of available hobby engines, a 0.60-cubic-inch engine was selected for use in the radio-controlled model program at Langley. With an engine of this size, the typical model would be about 1/6-scale with a wing span of about 4 to 5 feet.

A dynamically scaled model of this size would weigh about 14 to 16 pounds for a typical light general-aviation airplane, whereas a conventional hobby model of this size would only weigh about 6 to 8 pounds. It is obvious, therefore, that the wing loading of the model is relatively high which results in operating and flight characteristics that are much more critical than those experienced in a hobby-type flying operation. Because of the foregoing factors, it was found that one pilot could not effectively fly the model and

evaluate its flying characteristics at the same time. The test technique therefore utilizes a split control system and two pilots. One pilot operates the longitudinal controls while the other pilot operates the lateral-directional controls. Because the duties and workload of the pilots are reduced, each pilot can concentrate more fully on his area of operation and do a better job. This technique has proved to be very satisfactory, especially when conducting research tests on stalls and developed spins.

MODEL

The dynamically scaled radio-controlled model used in the NASA investigation was built by the Dynamic Model Development Section of the NASA Langley Research Center. The model was a 1/5-scale model of a typical low-wing single-engine light general-aviation airplane having a gross weight of 1500 pounds. The model had a wing span of 4.9 feet and a length of 3.8 feet, and when fully ballasted weighed 16 pounds. Two models were built so that there would be a backup model available in the event that a model was lost in a crash.

The geometric configurations of the four tails that will be used in the radio-control model flight-test program are shown in Figure 1, and three of these tails are shown with the model in Figure 2. Identical tail configurations will be tested in a follow-on full-scale flight-test program using the airplane shown in Figure 3. Three wings with the same rectangular planform, but with different airfoil sections (shown in Fig. 4), will be used in the radio-control model program.

MODEL CONSTRUCTION — In general, the scaled-down values of moment of inertia of the airplane about the roll and pitch axis are relatively low when compared to the values of moment of inertia of a radio-controlled model built by routine construction techniques. Therefore, special construction techniques

must be used during the design stage of the model in order to insure lightweight yet strong construction especially near the tail and wing tips of the model.

The NASA approach in the case of the present model was to construct the fuselage of laminates of fiberglass cloth impregnated with resin and the wings of balsa covered with fiberglass. In the case of the fiberglass components, as much resin as possible is squeezed out of the laminates in the molding process since extra resin contributes nothing to strength. The tail surfaces and wing tips were made of balsa and free-foaming plastic for light weight. Past experience at Langley has shown that this approach results in a strong, lightweight model.

MODEL BALLASTING — As pointed out previously, in order for the motions of a model to properly simulate those of a full-scale airplane, the model must be dynamically scaled; that is, scaled with regard to mass characteristics as well as with regard to geometric characteristics. In order for a model to simulate the mass characteristics of an airplane, it must have scaled-down values of the full-scale moments of inertia, weight, and center-of-gravity location. In order to accomplish such scaling for a model of a light general-aviation airplane, it is necessary to keep the weight of the model structure reasonably light so that the necessary equipment and ballast weights can be placed in the model in such a manner as to obtain the proper mass distribution without exceeding the scaled values. Calculations are performed to determine the proper weight of ballast required and its location as well as the location of additional equipment within the model.

Provision for attaching an apparatus to the model so that the model may be swung about its body axes to determine the moments of inertia is usually

considered in the design stage. In the present case, calibrated torque rods were used to determine the moments of inertia. Of course, other methods such as the bifilar pendulum system may be used.

The position of the center of gravity of the model along the X-body axis may be determined by suspending the model from two attachment points on top of the fuselage. A fore and aft location of the attachment points is chosen so that the center of gravity lies between them. A length of wire or cord may be attached to each of the attachment points and then brought together to form an inverted "V." The center-of-gravity position can be determined by suspending a plumb bob from the apex of the wires and adjusting the length of the wires until the model is exactly horizontal. Considerable error can occur with regard to the center-of-gravity position if the suspension point is too far above the model and if the model is not exactly level.

ENGINE AND FUEL SYSTEM — There are relatively inexpensive off-the-shelf engines which can be used in radio-controlled spin models. The engine should, of course, have a good record of running reliability and have sufficient horsepower for the model selected. The engine should have slow, reliable idle characteristics and be capable of going from idle to full power rapidly without engine malfunction. Emphasis should be placed on the ability of the engine to run reliably at idle power because both idle and full power must be used during developed spins.

The engine selected for the NASA work was a standard model airplane engine that had a displacement of 0.61 cubic inch and developed approximately 1.5 horsepower with glow-plug ignition. The engine idled satisfactorily at about 3000 rpm. It was mounted on its side in the model with the exhaust pointing downward. Since the engine was completely enclosed in the cowl, there was a

strong tendency for it to overheat and become damaged. Two approaches were considered to overcome this problem. In the first approach, the airflow would be directed from the air inlets in the cowl to the engine and then to the outside of the cowl by ducts. This approach, however, was considered to require excessive development. The second approach, which ultimately was used, consisted of adding a large heat sink to the cylinder of the engine. The heat sink consisted of four large circular aluminum fins attached tightly to the engine cylinder (see Fig. 5). This approach proved to be quite effective and the engine did not overheat on the ground or in flight.

Experience has shown that center-of-gravity position has a pronounced effect on the spin and recovery characteristics of an airplane. Thus, it is very important to restrain the center-of-gravity travel to a minimum while fuel is being consumed during the 10- to 12-minute flights. In order to minimize the center-of-gravity movement, the fuel tank (which contained 16 ounces of fuel) was mounted approximately on the center of gravity of the model. This approach resulted in the fuel tank being at the same level as the engine crankcase and about 7 inches behind the engine. Such a fuel tank location is not recommended by the engine manufacturers since most engines are designed to function properly only when the fuel tank is immediately adjacent to the engine. With the fuel tank located remotely from the engine, a serious fuel starvation problem was found to occur and cause the engine to stop running — especially during developed spins. The problem was resolved by using a pressurized fuel system with a commercially available pressure regulator.

SPIN RECOVERY PARACHUTE SYSTEM — A basic requirement in any spin recovery parachute installation is to locate the parachute in the tail of the aircraft or rearward of the aircraft structure. In either case, the parachute riser

attachment point should be located rearward of the aircraft structure. This approach will reduce the possibility of the parachute or riser fouling on the aircraft. If the parachute is located externally on the aircraft, it should be placed in as small a package as possible so that the package does not change the spin and recovery characteristics by substantially changing the aerodynamic and/or inertia characteristics of the model. The spin recovery parachute system used on the model was designed to meet these requirements and be simple. The parachute size was determined in the spin tunnel so that satisfactory recoveries could be obtained from all spin modes.

The parachute was a solid flat high porosity type approximately 20 inches in diameter. The riser length (distance from riser attachment point to skirt of canopy) was about 4 feet long. The parachute was held by elastic bands on a small platform which, in turn, was mounted on a boom to the fuselage (see Fig. 6). Thus, the platform as well as the riser attachment point was rearward of any portion of the model, thereby minimizing the possibility of fouling of the parachute on the model. A single servo was used to both deploy and jettison the parachute.

RADIO-CONTROL SYSTEM — A hobby radio-control system was used to fly the model. The system consists of a seven-channel proportional control unit which was modified into a split control system requiring two pilots. One pilot operated the rudder, ailerons, parachute deployment system, and telemetry unit, and the other pilot operated the elevator, flaps, and engine throttle.

INSTRUMENTATION — Two basic approaches to obtaining data might seem appropriate to radio-controlled model stall/spin tests of general-aviation airplanes. In the simpler approach, no instrumentation is carried onboard the model. A ground-based camera equipped with a telephoto lens is utilized to

record the flight motions, and an oscillograph can be used to record positions of the control sticks. In the second approach, a limited amount of onboard instrumentation would be used in conjunction with the foregoing ground-based equipment. The approach used will depend upon the type and amount of data desired.

In the simpler approach (no onboard instrumentation), the following data can be obtained: (1) how susceptible an airplane is to enter a spin, (2) whether the airplane will spin steep or flat, (3) rate of rotation, and (4) turns for recovery. Also, the gross effects of modifications (strakes, ventrals, tail designs, and other configuration changes) to the model on the stall/spin characteristics can be determined. If the second approach is used, additional information such as the angle of attack and sideslip of the model can be measured as well as the positions of the rudder, elevator, and ailerons with the following instrumentation system developed in the NASA tests.

The instrumentation onboard the model in the NASA investigation consisted of seven sensors which measured the angle of attack and sideslip at each wing tip and the positions of the three control surfaces. Four of the seven sensors were attached to miniature flow-direction vanes mounted on booms at each wing tip for measurement of the angles of attack and sideslip (see Figs. 2 and 7). The sensor measurements were transmitted to the ground by a telemetry system (seven-channel hobby transmitter) in the model. The transmitter was disassembled into its component parts (see Fig. 8), so as to save space in the model. Since the transmitter and receiver onboard the model were relatively close together, the frequency of the transmitter was different from that of the receiver, and thus no significant radio interference effects were encountered. A seven-channel hobby receiver on the ground picked up the signals from the

transmitter in the model and operated hobby servos to drive potentiometers whose signals were recorded on an oscillograph.

COLOR SCHEME — The color scheme of the model should be such that it can be seen easily throughout all phases of the flight. Contrasting colors aid considerably in quickly identifying the top and bottom of the model. The color scheme used on the NASA radio-controlled model was yellow on the fuselage and underside of the wing and red on the top of the wing. This color combination has proven to be satisfactory in flight tests.

TESTING TECHNIQUE

PRACTICE MODEL — In the NASA tests it was found advisable that before flying the dynamically scaled model, pilots should first fly an inexpensive, lightly loaded practice model of comparable size in order to gain flying experience. Additional weight should then be added to the practice model until it has approximately the same wing loading as the scaled model. After the pilot becomes experienced in flying the heavy practice model, he should then transition to flying the test model in a lightweight condition.

LIGHTLY LOADED TEST MODEL — It seems advisable to fly the test model initially at the lightest weight possible with a forward center-of-gravity position. After the lightweight model flights have been completed, the model might be ballasted without the instrumentation and flown again.

BALLASTED TEST MODEL — When the fully ballasted and instrumented test model is flown, a "race track" type of flying pattern seems to be the most efficient and effective for conducting the spin tests. When using this technique, the model is flown in an oval pattern and the model is always out in front of the pilots and photographer. The flight pattern should never be overhead because of the difficulties associated with observing the attitude and

and tracking the motion. The spin entry maneuver should be executed on the leg of the pattern nearest the pilots and in, as nearly as possible, the same general area. This approach aids the photographer in tracking the model as it is maneuvered. Also, the photographer and pilots should be in close proximity so that the pilots can inform the photographer as to when they are going to initiate the spin entry and make any other pertinent comments necessary to facilitate tracking of the model.

Since the model, as previously mentioned, will be flying at distances generally exceeding 1000 feet, it is sometimes difficult to see it clearly and often results in poor control of the model, which is unacceptable for stall/spin research. In an attempt to alleviate this problem, small binoculars (opera glasses) were attached to a frame to be worn by the pilots (see Fig. 9). The binocular system was designed to be flipped upward to a raised position when necessary to unshield the pilot's eyes. Preliminary results are inconclusive in that the binoculars helped by increasing the image size of the model, but in some cases the pilot lost sight of the model because of his limited vision through the binoculars.

PHOTOGRAPHY

A system consisting of a tripod-mounted electrically driven 16-mm movie camera equipped with a 12-inch telephoto lens (Fig. 10) was developed to take motion pictures of all flights. It was found necessary to use a 12-inch telephoto lens because of the altitude at which the spin entries were initiated (approximately 1000 ft). Manual tracking of a model during a spin entry, developed spin, recovery, and ensuing dive with a telephoto lens, however, proved to be very difficult. After an evaluation of commercially available tracking systems, it was decided to develop a new system; and the system that

resulted proved to be adequate for tracking the model. The major parts of the systems are: (1) a steadying device resembling a gun stock, (2) pivot points for rotating the camera in elevation and azimuth having variable friction capability, and (3) an optical tracking sight with a reticle sized so that appearance of the model within the reticle insured camera coverage of the model motions. The reticle size was designed for sighting a model at distances of 1000 feet, or greater. No magnification of the model image was necessary in order to track the motions. It is desirable, of course, to have an experienced tracker when taking motion pictures, and a considerable amount of practice is necessary to become proficient at this task.

TEST SITE

The NASA model tests were conducted at West Point Airport, West Point, Virginia. The airport runways are in the form of an equilateral triangle and are approximately 5000 feet long. Runways at least 1000 feet long and 100 feet wide appear to be required for the model scale used, especially when attempting to land the model since the landing approaches are fast.

The noise level in the test area was found to be an important factor since it is necessary for the pilots to be able to hear the engine running at all times, and to be able to carry on a conversation during the test flights. The importance of hearing the engine is that if the engine should begin to run erratically, or stop, during any phase of the flight, the pilot immediately can take appropriate action to avert an unexpected stall or loss of control and possible loss of the model.

PART II -

APPLICATION OF RADIO-CONTROLLED MODEL TESTING TECHNIQUE

PIPER AIRCRAFT CORPORATION

SPECIFICATIONS OF THE PIPER MODEL

A 1/6-scale remotely piloted model aircraft was designed, built, and tested to determine its spin characteristics and recovery techniques. The results were related to a full-scale prototype airplane. The model was a twin-engine aircraft, geometrically and dynamically similar to a full-scale airplane. See Figures 11 and 12.

The following specifications defined the first model:

1. Model scale, 1/6 full size.
2. Model gross weight, less ballast not to exceed 15 pounds, fully equipped, fueled, and ready to fly.
3. Engines (two required) to be 0.60 inch³ displacement with the right engine having counterclockwise rotation, the left engine having clockwise rotation as viewed from cabin (down at center).
4. Fuel system to be designed to insure against engine failure during the spin due to fuel starvation.
5. Fully retractable tricycle landing gear structurally and functionally capable of handling a flight weight of 23 pounds.
6. Model shall be equipped with an emergency spin recovery parachute.
7. The following functions shall be controlled by the radio transmitter, aileron, elevator, rudder, flaps, landing gear, independent engine controls, nose wheel steering, spin parachute deployment and release.
8. Provisions shall be made for the installation of ballast for inertia scaling.
9. Modification components will be interchangeable or removable.
10. Tolerances:
 - a. All linear dimensions and fuselage contours shall be within $\pm 1/32$ inch.

- b. All wing and control surface contours shall be within $\pm 1/64$ inch.
 - c. Wing twist from root to tip chord shall not exceed $\pm 1/4^\circ$.
 - d. All angles of the assembled components shall be within $\pm 1/4^\circ$.
11. Details such as navigation lights, radio antennas, pitot-static tubes, door handles, and so forth, need not be simulated.
 12. Propeller spinners shall be installed but need not be to exact scale.
 13. Gear doors shall be installed and functional.
 14. All external surfaces shall be smoother than 64 microinches and shall be fuel proofed.
 15. All purchased parts, radio equipment, engines, retractable gear, and so forth, shall be of proven quality and reliability.

CONSTRUCTION

The model was designed and constructed by Jim Jackson, an employee of Piper and an experienced model builder, who constructed two models under contract.

The fuselage was a fiberglass shell made in two halves from a two-piece female die made of fiberglass. The female die was taken off an accurately built metal and clay half model. The metal and clay half model was built from scaled-down production contour drawings giving bulkhead shapes and loft line locations. The bulkhead halves were cut from metal and spaced on a rigid piece of aluminum. Rigid filler was added to within 1/4 inch of the outside edge, then modeling clay was used to finish the shape. Fly screen type material was used to smooth the final surface of the clay before it was painted with body paint. A release agent was then sprayed over the clay model. A heavy fiberglass female mold, rigidly supported, was taken over the clay fuselage section. The mold can be used to make as many fuselage half sections as desired. A

release agent must be sprayed or painted on each time a part is made. When making the final fuselage part, it is important to use thin fiberglass cloth and squeegee away all excess resin to keep weight at a minimum. Two layers of 10-ounce fiberglass cloth were used from the nose to just aft of the wing attach point; one layer was used for the tail cone. Plywood bulkheads were added when the halves were being glued together in the female mold. Typical model techniques were used in completing the fiberglass fuselage.

The wing core was made of 1.6 lb/ft³ expanded polyurethane foam and cut undersized to shape with a hot wire, then covered with 3/32-inch-thick balsa (4 to 6 lb/ft³ density). The final wing section contours were sanded into the slightly oversized balsa skins. The balsa was then covered with 3 oz/yd² fiberglass cloth and epoxy resin that was brushed and squeezed through the cloth.

The horizontal tail (stabilator), vertical tail, ailerons, and flaps were of built-up balsa and foam construction covered with 3 oz/yd² fiberglass cloth and epoxy resin.

The stabilator was mass balanced in the leading edge to 100% static balance. The rudder was mass balanced to 50% static balance, trailing edge heavy. The ailerons were unbalanced. No free play in the surface controls was allowed.

A strengthened version of a commercially available retractable nose and main landing gear was initially used employing a Freon pressure retract system and pneumatic actuating cylinders. The nose gear had to be additionally strengthened due to the high landing loads.

Freon was found to be a poor pressure agent since it is temperature sensitive and the present tests were conducted during the winter in Central

Pennsylvania in temperatures as low as 15° F. Dry compressed air was substituted for Freon because it is not as temperature and pressure sensitive.

It was found that the chordwise location of the main gear relative to the center of gravity and the ground angle of attack was critical for proper rotation at lift-off. The main gear was 0.25 to 0.375 inch aft of the center of gravity, and the ground angle of attack of wing was set at 2° nose up for ease of lift-off and protection of the nose gear.

The full-size airplane incorporates opposite rotating engines with down at the center rotation. Two Super Tigre Bluehead engines (0.60 cu-in. displacement) were used on the model. This engine is a two-cycle single-cylinder model airplane engine equipped with adjustable carburetor and exhaust restrictor. Ignition is by glow plug which is heated during starting by a 1.5-volt battery. By rotating the front intake assembly 90°, the right engine was made to run backward without measurable loss of power or rpm.

The propellers were all hand made from maple blocks because left-hand rotation props could not be purchased. Left- and right-hand 12-5 (diameter 12 in., pitch 5 in. advance per revolution), 12-6, and 12-7 propellers were made for thrust coefficient determination. A hand-carved propeller could be finished in semimass production in 40 minutes of working time. Marking dies for blade-shape and pitch shape were used, and then accuracy held to $\pm 1/2$ -inch of pitch over $3/4$ of the outer blade span. It was really heartbreaking to see both props shatter when the nose gear collapsed. This happened four times.

CONTROL SYSTEM

Discussions with Todd Burk and Jim Bowman at NASA Langley indicated that two pilot operations would provide smoother spin entries and spread the workload. The primary transmitter control box was capable of handling all controls

except power. Before entry into the spin was started, the elevator was switched to the secondary control box.

The control functions which were available are shown below along with the control box which had that function. A World Engines radio-control system was modified to eight channels and the motor and elevator functions were split out and routed to a second control box. See Figure 13.

Elevator	- Primary transmitter or secondary control box
Rudder	- Primary transmitter
Aileron	- Primary transmitter
Gear/flap	- Primary transmitter
Spin parachute deploy/release	- Primary transmitter
Left engine	- Secondary control box
Right engine	- Secondary control box
Onboard camera channel	- Primary transmitter

The primary transmitter was also rigged to allow either Mode I (aileron, right stick; elevator, rudder left stick) or Mode II (aileron, elevator right stick; rudder, left stick) by flipping a selector switch on the primary transmitter.

The throttles were set up much like the throttles on a full-scale twin-engine airplane incorporating dual controls. This resulted in very smooth positive throttle control and ease in synchronizing the two engines. The control box incorporated a movable stop on each throttle which would restrict the power to the desired preestablished rpm level for duplicating the desired thrust in flight.

The servos were production World Engine model S-5 units. The horizontal tail on this model is an all flying tail (stabilator) and the hinge

characteristics were calculated to be near the stall limit of the servo when the surface was fully deflected. No difficulty, however, was encountered at speeds up to approximately 120 mph.

The control surface hinge locations and travels were the same as the full-scale airplane. The flaps were constructed in such a way that they were properly positioned in the fully retracted and fully extended positions only, as a simple single point hinge was used in lieu of a slotted track.

FUEL SYSTEM

The fuel system was conventional in that a weighted flexible tube within the tank was used to feed the engine. The tank also had a filler and vent tube. The tanks were located in the nacelle just aft of the firewall. The original design had integral fiberglass tanks built into the nacelle. The model fuel (menthol alcohol, nitro methane, and castor oil) attacked the composite polyester, epoxy fiberglass resin, softened the material and put pinholes in the tank. A metal tank was then constructed and installed in each nacelle.

PARACHUTE AND PARACHUTE RECOVERY SYSTEM

A tubular paper cylinder 1-1/2 inch diameter, 9 inches long, was used to contain the spin parachute inside the fuselage tail cone. A smaller diameter tubular cylinder, 1/2 inch diameter, 9 inches long, was attached to the inside of the parachute cylinder to contain the shroud lines and riser line. The opening in the fuselage was covered by an aluminum plate which had a servo-operated release mechanism. The parachute riser line was connected to the plate. On the forward end of the plate was the pin release mechanism and a hook to which rubber bands were attached and stretched to a tail boom. Their

purpose was to provide the necessary acceleration to pull the parachute out and clear the horizontal tail when the parachute was deployed.

The parachute was a scale version of a full-scale ring-slot parachute sized by James E. Brown of Piper Aircraft, using data in NACA Research Memorandum L8D27. The full-scale parachute was determined to have a flat diameter of 11.3 feet. The drag coefficient used was 0.55. The model parachute had a flat diameter of 22.5 inches with 24-inch-long shroud lines, spaced at 20° intervals, for a total of 12 shroud lines. See Figure 14.

The spin parachute was included in the design of the model for two reasons: first, to provide substantiating data of size, riser, length, and drag for correlation with the full-scale parachute, and second, to provide a means of model recovery from an unrecoverable spin.

The parachute was very useful in reducing the landing roll and postlanding taxi speed. The parachute was deployed immediately upon touchdown. It stabilized the model directionally and would slow the model enough so that turn-around and slow taxi could be achieved. The model was not equipped with brakes and the parachute was a reliable substitute.

The mechanism which was used to trigger the deployment and release mechanism is shown in Figures 15 and 16. The deployment of the parachute was activated by an "off-on" switch. When the switch was returned to the normal "off" position, the riser line was released. This mechanism worked fine and prevented the parachute from being released prior to deployment.

CONFORMITY INSPECTION

Upon completion of the assembled model, a complete conformity inspection was made as follows:

1. Basic parameters such as dihedral, wing incidence, wing twist, and tail incidence were checked on a surface table.
2. Templates were made to check the wing contours and surface travels.
3. The engine alignments were checked with the propellers installed and fuselage level on the surface table.
4. It is not necessary to duplicate items like antennas, door handles, position lights, and so forth. Minor contour changes due to cylinder head protrusion, intake or exhaust ports, tail booms, and so forth, are not critical.

MASS AND INERTIA PROPERTIES

Discussions with James S. Bowman and Todd Burk of NASA Langley indicated that one of the most important parameters to scale was the inertia properties. A simple and accurate method of determining the model inertia is the bifilar swinging method. This method requires hanging the model by two cables (light stranded or solid wire about 0.016 diam.) with the plane created by the two cables, passing through the model center of gravity. See Figure 17. The cables should be equally distant from the center of gravity. The rolling, pitching, and yawing moments of inertia can be determined depending on which way the model is hung. The equation for determining the moment of inertia is:

$$k^2 \frac{386 \times t^2 \times D^2}{16L \times \pi^2} = \frac{386 \times t^2 D^2}{16L \times 3.142^2}$$

and

$$\tau = \frac{k^2}{144} \times \frac{W_M}{g} = \frac{k^2}{144} \times \frac{W_M}{32.2}$$

where:

k = Radius of gyration - inches

t = Time in seconds for one cycle

D = Distance between cables - ft

L = Length of cable - ft

W_M = Weight of model - lb

I - Moment of inertia - slug-ft²

To start the model oscillating, rotate it symmetrically about the center of gravity approximately 20°. The amount of rotation is not critical as long as the motion is symmetrical and oscillating in one plane.

It is very important that the empty weight of the model be kept down so that it can be properly ballasted. If there is very little ballast weight to work with, it is possible that all of it may be used up in getting the proper moment of inertia about one axis, and none left for the other two.

If the unballasted model is swung and the moments of inertia are determined, the optimum ballast location can be analyzed by iteration based upon space available within the model. The final ballasting should be verified by test.

To scale the moments of inertia, the following factor should be applied:

$$F = \left(\frac{1}{N}\right)^5 \frac{\rho_M}{\rho_A}$$

where

N = Model scale

ρ_M = Air density at model altitude

ρ_A = Air density at full-scale a/c altitude

Considering full-scale moments of inertia of:

$$I_X \text{ roll} = 3305 \text{ slug-ft}^2$$

$$I_Y \text{ pitch} = 2114 \text{ slug-ft}^2$$

$$I_Z \text{ yaw} = 5064 \text{ slug-ft}^2$$

and a scale of 6 with the model at 1000 feet altitude and full-scale airplane at 10,000 feet altitude the factor would be:

$$F = (1/6)^5 \frac{(0.002304)}{(0.001756)} = 0.0001687$$

Factoring the full-scale values we have:

$$I_X \text{ roll} = 0.557 \text{ slug-ft}^2$$

$$I_Y \text{ pitch} = 0.356 \text{ slug-ft}^2$$

$$I_Z \text{ yaw} = 0.854 \text{ slug-ft}^2$$

THRUST SCALING

The model thrust program scheduled power-on entries into the spin. The amount of power must be matched by holding the propeller advance ratio constant.

First obtain by tests or calculate the full-scale power-on stall speed in each configuration of test. Using the speed and the rated engine speed and propeller diameter, calculate the full-scale value of the advance ratio, J.

As

$$J = \frac{V}{nD_p}$$

where

$$V_s = \text{stall speed} - \text{ft/sec}$$

$$n = \text{engine speed} - \text{rev/sec}$$

$$D_p = \text{propeller diameter} - \text{ft}$$

Example: Stall speed 63 mph (92.4 ft/sec) 2700 rpm and 6 ft propeller diameter.

$$J = \frac{92}{\frac{2700}{60} \times 6} = 0.342$$

Next, calculate the full-scale thrust at the power-on stall speed. Substituting known values of T_A , n_A , D_{pM} , and D_{pA} make a plot of T_M versus n_M (see Fig. 18) using the following equation:

$$\frac{T_M}{T_A} = \frac{n_M^2 \times D_M^4}{n_A^2 \times D_{P_A}^4}$$

where

T = thrust - lb

M = model

A = full-scale airplane

The model power-on stall speed should then be calculated. Determine the proper model engine speed using the calculated J above and $n_M = \frac{V_{SM}}{J \times D_{P_M}}$

Example: $n_M = \frac{60.1 \times 60}{0.342 \times 1} = 10,544 \text{ rpm}$

Entering the plot of T_M versus n_M above the desired model thrust may be determined.

Next, determine the actual model thrust and engine speed of various propellers using an instrumented engine thrust test stand. See Figure 19. The thrust test stand was installed on top of a truck along with an airspeed boom. The thrust of various model engine speeds was measured for a vehicle airspeed equivalent to the stall speed of the model. Remove the propeller and measure the tare drag of the engine and test stand at the same vehicle airspeed. The actual thrust will then be engine thrust measured plus tare drag. Plot the results of several propellers on the graph presenting the previously calculated n_M versus T_M . Refer to Figure 18. Where the desired and actual match, this is the proper propeller and engine speed setting.

Retest the dynamic thrust and model engine speed on the moving test stand using the selected propeller. Stop the test stand (stop truck) and measure the static rpm and thrust. This value of engine speed may be used at the test site to duplicate the desired inflight thrust and engine speed.

PARACHUTE RISER LENGTH AND CHARACTERISTICS

To arrive at a parachute riser length which might result in recovery from a stabilized uncontrollable spin, a test was set up to establish the optimum length. The fuselage and tail section of the model were positioned on top of a truck with the model at an angle of attack to the relative wind of approximately 75° to 80° . Using a vehicle airspeed of 40 ft/sec (estimated vertical descent velocity) the riser length was varied. The suggested optimum length was that which yielded the shortest riser length which would allow the parachute to be in light turbulence from the wake of the horizontal tail and aft fuselage. If the parachute is perfectly smooth, the length is too long; if the parachute collapses, it is too short.

Unfortunately, the actual optimum riser length was never tested in free flight. In one case where the spin parachute was deployed in an uncontrollable spin, the rubber bands on the deployment system did not provide enough power to send the parachute aft of the horizontal tail; and thus the riser line went forward of the tail reducing the moment arm of the fuselage and tail boom.

It is important that the riser attachment be aft of the horizontal tail. If it is not, the riser line may hold the elevator in the up position despite selected control position.

A powerful parachute ejection system is necessary to throw the parachute clear of the tail. This system should be tested with the model mounted on the vehicle at a speed 1.3 times the estimated vertical descent velocity to provide a margin of safety.

Successfully deploying the spin parachute in level flight or in a normal spin does not thoroughly test the system. It was found that controlled flight could be maintained with the parachute deployed by using full power and

lowering the aircraft nose to retain flying speed. Altitude, however, could not be held with spin chute deployed.

ENGINE OPERATION

A most important item is reliable engine operation. The engine must operate throughout its throttle range with smoothness and stability. The idle must be set for reliable running but not so fast it will accelerate the model on the ground.

For twin-engine aircraft, the engines must be synchronized for symmetric power.

Mixture should be set for proper running with the model nose up 45°.

If the engines are new, they should have a bench-run break in period in order to achieve stable engine operation.

Mufflers were not used due to power loss and nonscale drag considerations.

RADIO OPERATION

The radio equipment must have proven reliability, preferably by having been previously flown in other aircraft. The frequencies are your choice but avoid the 27 mh range due to illegal citizen-band radio operation. Many people using the citizen band are operating their transmitters in excess of 100 watts (5 watts legal) which will affect any model on an adjacent frequency within 1 mile of the flying site. Frequencies in the 72 mh are acceptable or in the 53 mh if the operator has a technician's amateur radio license.

The servo travel should be adjusted to just hit the control stops when fully deflected. If the servo is driven against a stop with remaining travel, this operation will cause high current drain and could cause failure of the radio system. The engine controls have spring overrides incorporated on the

throttle arms to permit full throttle and low idle without running the servo to its limit, thus causing an electrical overload.

The servos must have good proportional qualities and accurate centering. There should be no chatter or step operation.

The nickel cadmium batteries of the transmitter and receiver should be properly deep cycled several times if they have not been used. Normal charge, discharge rate will be 10% of battery capacity in milliamperere hours for the deep cycling conditioning.

As in any radio-controlled model, vibration isolation is necessary. All airborne equipment must be isolated. Instructions are given with the radio equipment manuals. Metal-to-metal contact, which is not bonded, should be avoided. For example, avoid metal control horns and metal clevis. Use a nylon horn with a metal clevis.

LANDING GEAR SYSTEM

The landing gear and gear retracting mechanism must be rugged enough to withstand the hard landing loads which will be imposed by the heavy model. The nose gear seems to get the most abuse. The main gear usually retracts spanwise, whereas the nose gear retracts lengthwise and is subject to unwanted and forced retraction. A good static test for the nose gear is to place the weight of the model on the nose gear in an aft direction. This can be done by holding the fully equipped model on the edge of a table with its nose down and resting on the nose wheel. There should be no significant deflection of the nose gear mechanism. Steel gear legs of 3/16-inch-diameter are satisfactory for models up to 23 pounds.

The main gear chordwise location is critical. The main gear should be located as close to the aft center-of-gravity limit as possible (0.25 to

0.38 in. aft of the center of gravity) to permit easy rotation during lift-off. The configuration of the model had the main landing gear well aft of the aft center of gravity and, as a result, a large down tail load was required for rotation. Once the model became airborne, this down tail load caused the model to pitch up violently which could result in an accelerated departure stall. The solution which was used was to lengthen the nose gear, placing the model in a 2° nose-up attitude on the ground which allowed the model to fly off the ground with little rotation.

The gear retracting mechanism must work smoothly with no binding in any position. The gear operation must be checked following each landing for proper fit of the wheels in the wheel wells and landing gear alinement.

GROUND SUPPORT EQUIPMENT

The ground support equipment for the flight program included the following:

1. Milliken 16 mm movie camera with 12-inch telephoto lens. (Requires 110 volt ac.)
2. Camera tripod.
3. 12-volt battery.
4. 12-volt dc to 110-volt ac converter.
5. Tools for assembly and minor repairs.
6. Fuel and fuel pump.
7. Starting battery.
8. Spares including props, wheels, glow plug, fuel line, and so forth.
9. Tape recorder and collar mikes for each pilot to record comments during the tests.

CAMERA CHECKOUT

The primary data readout was film obtained from a 16-mm movie camera with a 12-inch telephoto lens. The bore sighting, film loading, and operation of the camera must be practiced prior to recording data flights...

Bore sighting the camera and monocular must take place each time the camera is set up or the film changed. This involves placing an optical device in the camera before the film is loaded and sighting through this device at an object approximately 1000 feet away. The monocular is the tracking device and it must align with the camera. The magnification of the camera is such that a 6-foot span model will take up one-third of the picture at a distance of 1000 feet. If the bore sighting is not done accurately, nothing but sky will be obtained when the film is developed.

Loading of the roll film should be practiced because it is not simple to correctly load. The camera is high-speed (64 frames/sec) and the film will break if it is not properly threaded. Colored film works very well, and although it is expensive, is worth it.

It is advisable to practice tracking a model at the local radio-controlled model field. It takes coordination and concentration to keep the model centered in the cross hairs. During test runs, the model should not be flown overhead since the camera will not track vertically.

A hand-held camera should be used for photographing the take-off and landing sequences, if desired. The telephoto camera cannot be scanned or refocused properly and it will only record a small portion of the aircraft. It is recommended that all take-offs and landings be photographed.

TEST SITE

The best choice for a test site is an abandoned military or civil airport, or the cross runway of a civil aviation airport. The take-off surface must be a relatively smooth hard surface and at least 1000 feet in length and 100 feet wide.

Operations were attempted at the Lock Haven airport which has a single runway, but full-scale traffic was a problem, principally from the full-size aircraft noise. It must be possible for the radio-controlled model engines to be heard clearly at all times. The engine sound gives a good indication as to how the flight is going. If an engine quits, it is necessary to know it immediately and not by visual indication of descent. The speed of the model can also be accessed by engine sound.

Remaining flights were conducted at the Mid State Airport at Philipsburg, Pennsylvania, about 30 miles west of Lock Haven. This is a state-owned airport with a Flight Service Station on the airport but no control tower. The airport has cross runways with general-aviation and commercial traffic.

State airport officials, Mr. Fred Osman and Mr. Alfred Childs, were very cooperative with Piper's efforts and authorized the use of the state airport at Philipsburg.

The FAA Flight Service Station (FSS) personnel at the airport also assisted Piper's efforts by putting out a NOTAM closing the runway on which the model tests were being conducted. The model was not flown over the active runway.

Communication was maintained with the FSS on standard FSS frequencies. They were advised when the model was going up and when it had landed. This procedure worked out very well and created no problem for airport users.

Experience indicated that the test site should be near the home base since problems may cause immediate termination of the flight program.

FLIGHT CONDITIONS

The ceiling must be 2000 feet or better and the visibility 5 miles or better to fly the model. The cloud cover does not affect the model pilots; however, camera lens adjustments are required with changing light.

The wind limit was 10 knots principally due to turbulence or cross wind while landing.

Flights were conducted early in the morning when the sky was light enough to permit photography. Tests were usually terminated about 11 a.m. due to increasing wind conditions.

OPERATING PROCEDURE

Data flights must follow a preplanned test schedule. Three entries of each configuration should be tested. A test pattern should be established which will have the sun position at the pilot's back and permit the tracking camera to continuously track the flight pattern. If the tracker loses the model, it may take 10 to 20 seconds to find it again.

The camera should be started at the pilot's command approximately 5 seconds prior to the stall. The camera should be stopped when the spin recovery is complete and the aircraft back to level flight. Secondary stall/spins can occur after recovery has started, so stay with it until it is obviously in level flight.

The procedure in the present investigation was to enter the stall from right to left with the spin entry directly in front of the camera. The spin was held for three turns before recovery was initiated. The model has such

high roll-yaw rates that it cannot be arrested after the first turn and it was desirable to have the spin stabilized prior to recovery.

Recovery techniques should be preplanned and committed to memory. There is no time to think, it must be mechanical motion.

Power-off spin entries should be tested first both clean and dirty.

SHAKEDOWN FLIGHTS

The two engineers who flew the model prototype were well qualified recreational radio-control model fliers. The speed and characteristics of this model prototype, however, was a new experience. In order to become more familiar with the take-off and landing speeds and the high rate of sink, a plastic and foam ARF (almost ready to fly) model was put together and was progressively loaded up to 2-1/2 times its original design gross weight. One of the engines and the radio gear from the test prototype was used for these practice flights. It also provided an opportunity to practice with the controls split and two-pilot operation.

Being a full-scale pilot does not qualify a person to fly a radio-controlled model. The orientation problem is something that must be overcome through years of practice.

The first flights on the twin-engine model were conducted without ballast to check out the general handling qualities and to solve the inherent operational and equipment problems. Three accidents occurred which resulted in extensive repair but each time the aircraft was back in the air within 3 days.

Gear and flap operation was tested and stall entries were investigated on the third and fourth flights. Due to gear problems early in the program — collapsed nose gear — only one flight per day could be obtained, then home for repair.

The fifth through ninth flights were witnessed by Mr. Todd Burk and Mr. Dave Robelen of NASA Langley. After observing four successful flights, they made the following recommendations which were followed in subsequent data flights.

1. Greater consistency must be attained in entering the spin smoothly and with wings level.
2. Enter the spin at a lower altitude if practical.
3. Paint the bottom of the aircraft a color which will contrast with the sky.
4. Spin entries in the same configuration should be repeated several times.
5. Before reloading the 16-mm camera at the end of each roll, bore sight the camera again even though there is no reason to suspect the sighting unit is out of alinement.

Our original spin entry altitude was about 1500 feet above ground level and was later brought down to about 1200 feet.

When ballast is added to the model it should be done in steps, two or perhaps three. As the center of gravity goes aft, the stability of the model is reduced and the model becomes more difficult to fly. A scale model airplane has much less tail volume than a conventional radio-controlled model and will react very differently to controls.

The model flies essentially stick fixed since it has an irreversible control system. In the power-on stall, the model and full-scale aircraft may be unstable stick fixed although the full-scale aircraft would exhibit stick free stability. This means to the model pilot that during the stall entry from trim, forward stick will be required to arrest the nose-up pitch rate. This is

tricky to get adjusted to and requires several approaches to the stall/spin to get an acceptable entry.

DATA FLIGHTS

Spin entry tests were conducted on the model with power off as well as partial and full symmetrical power. In addition, asymmetrical power spin entry tests were conducted. Power effects were evaluated by cutting the engines at 1/4, 1/2, 1, and multiple turn points. The spin was still allowed to continue through three turns from the entry. Ailerons with and against the spin were also tested and these control deflections were found to change the spin characteristics.

Asymmetric power was found to cause autorotation rates twice the normal spin rate. The rate of descent in the flat asymmetric power mode was reduced by about one-third. Flat spins can be readily produced with asymmetric power, therefore they should be approached with caution. It was found that the retreating engine had a tendency to quit in the stabilized flat spin mode. This tendency was believed to be caused by the reverse airflow on the propeller stalling the engine and would occur only after approximately 10 turns in the flat mode.

A successful single-engine recovery, approach, and landing was accomplished after an engine stoppage in the spin. The power was reduced to idle on the good engine for recovery, then reapplied (full power) after the model had attained level flight following the recovery dive. Level flight was able to be maintained on one engine with gear and flaps retracted. The gear was not extended until the last few seconds before touchdown in order to keep the drag to a minimum during approach.

Model testing can define recovery techniques for the full-scale airplane. Rudder only and stabilator only recoveries were tested, as well as the effect of ailerons on the recovery characteristics.

Tests of the full-scale airplane showed good correlation with that of the radio-controlled model in both spin and recovery characteristics.

PROGRAM COSTS

Piper's program called for two complete models except for installation of the radio equipment, engines, and landing gear in the second model.

The first model was ready for ballasting 9 weeks from date of order. The second model was complete for flying in 11 weeks from date of order. The flight program was completed 8 weeks after the second model was completed.

The cost of the program including two models, support and repair, manpower, expense and travel costs, and data reduction was less than \$7000.

Several trips were made to the Langley Research Center to consult with NASA people and should perhaps be included in the total program costs.

SUMMARY — PART I (NASA)

1. A low-cost radio-controlled model testing technique utilizing hobby equipment has been developed for use by general-aviation aircraft manufacturers to study the stall/spin characteristics of aircraft. Also, the parachute size and riser length required for emergency recovery in full-scale spin tests can be determined by using this technique.

2. An economical telemetry package has been developed that utilizes hobby equipment to transmit seven channels of information.

3. Miniature flow-direction vanes equipped with potentiometers have been developed to measure the angle of attack and sideslip of the model.

4. A manual tracking system for photographing airborne models has been developed. The system utilizes an easily portable tripod-mounted 16-mm movie camera with a 12-inch telephoto lens that appears to be superior to any commercially available system.

SUMMARY — PART II (PIPER)

1. Radio-controlled scale model testing is a valid method of establishing the spin characteristics and recovery techniques of a full-scale airplane.

2. Construction techniques are relatively simple and can be performed by any equipped model shop, however, care must be taken to insure model moment of inertias can be scaled to proper values.

3. Most accessories and components are commercially available or can be modified for use.

4. Flying techniques must be practiced, however, any highly competent RC model flier can eventually handle the program.

5. NASA will cooperate with industry and provide assistance and guidance.

6. Program cost and lead times are within the grasp of most aviation industry or educational institution budgets and schedules.

REFERENCES

1. James S. Bowman, Jr., and Sanger M. Burk, Jr., "Stall/Spin Studies Relating to Light General-Aviation Aircraft." SAE Report No. 730320, Business Aircraft Meeting, Wichita, Kansas, April 3-6, 1973.

2. James S. Bowman, Jr., and Sanger M. Burk, Jr., "Stall/Spin Research Status Report." SAE Report No. 740354, Business Aircraft Meeting, Wichita, Kansas, April 2-5, 1974.

FIGURE CAPTIONS

Figure 1. Tail configurations to be tested on NASA radio-controlled low-wing model No. 1.

Figure 2. The NASA 1/5-scale radio-controlled low-wing model No. 1.

Figure 3. The NASA full-scale test airplane and corresponding 1/5-scale radio-controlled model and 1/11-scale spin-tunnel model.

Figure 4. Wing airfoil sections for NASA radio-controlled low-wing model No. 1.

Figure 5. Model engine with heat-sink (aluminum fins) attached.

Figure 6. Spin-recovery parachute system used on NASA radio-controlled low-wing model No. 1.

Figure 7. Flow-direction vane used to measure angles of attack and sideslip on NASA radio-controlled low-wing model No. 1.

Figure 8. Seven-channel telemetry system used in NASA radio-controlled low-wing model No. 1.

Figure 9. Head-mounted binoculars for tracking model.

Figure 10. NASA manual tracking system for photographing radio-controlled models.

(a) Radio-controlled model ready for flight.—

(b) Model, control boxes, and flight crew. Left to right: C. Wilson, Jr., J. Jackson, J. Brown, and D. Roemer.

Figure 11. Piper radio-controlled model and flight crew.

Figure 12. Three-view drawing of Piper aircraft.

(a) Transmitter and primary control box.

(b) Secondary control box with throttles and elevator controls.

Figure 13. Radio-control equipment.

Figure 14. Model ring slot parachute with dimensions.

Figure 15. Servo parachute deployment-release actuator.

Figure 16. Parachute release mechanism.

Figure 17. Bifilar swinging method to determine inertial properties.

Figure 18. Engine speed (n_M) versus net thrust (T_M).

Figure 19. Thrust test stand. All dimensions are in inches.

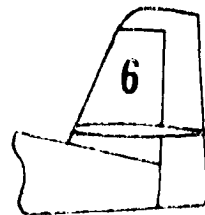
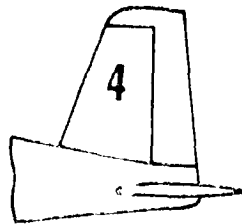
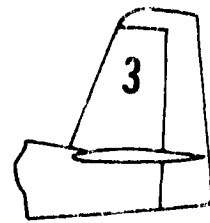
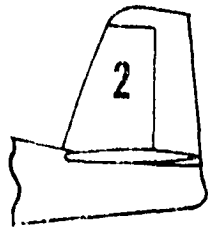

Figure 1. Tail configurations to be tested on NASA radio-controlled low-wing model No. 1.



Figure 2. The NASA 1/5-scale radio-controlled low-wing model No. 1.

**ORIGINAL PAGE IS
OF POOR QUALITY**

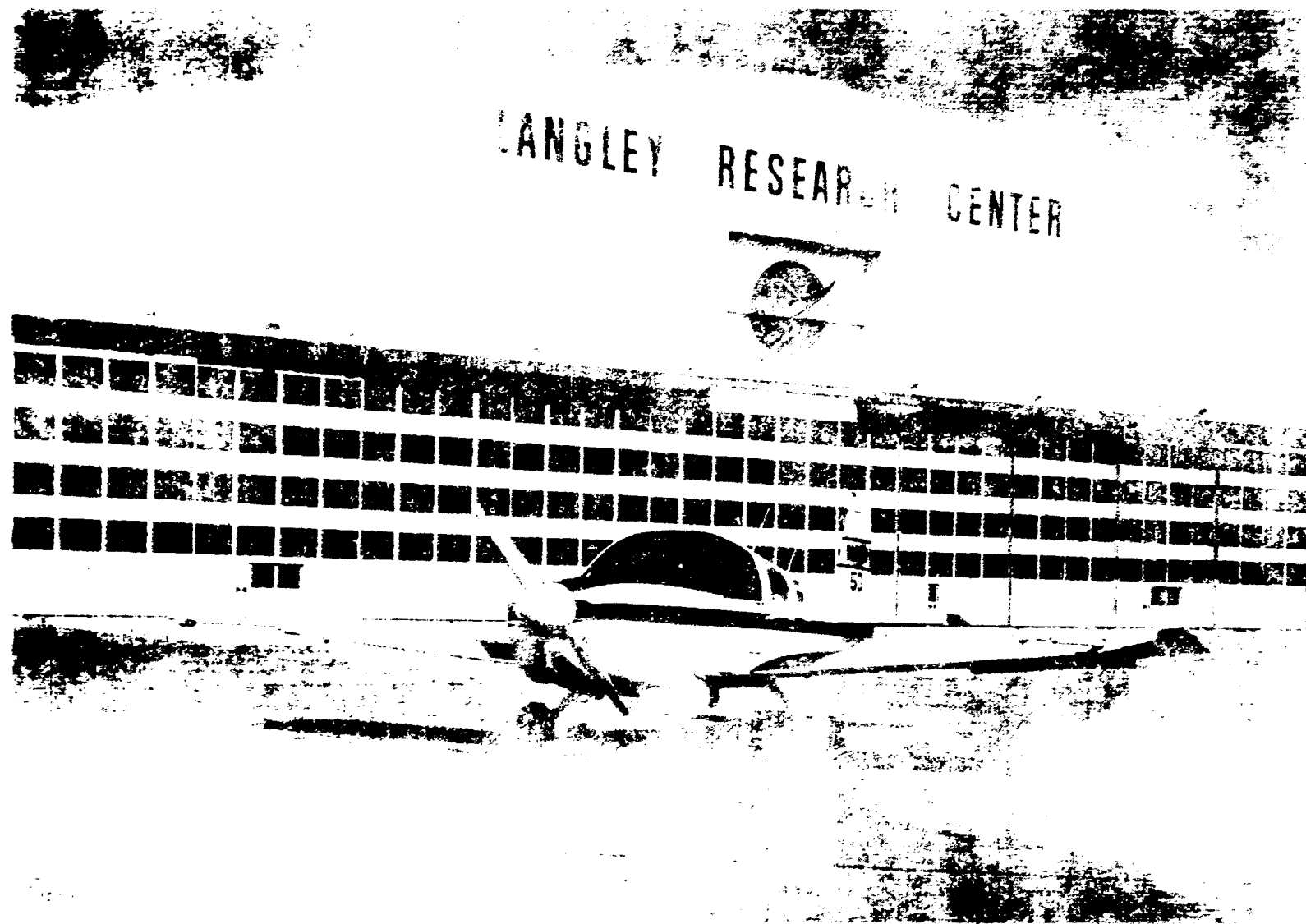
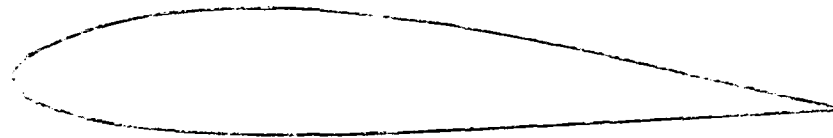
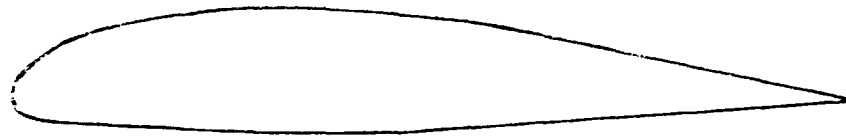

Figure 5. The N3A full-scale test airplane and corresponding 1/5-scale radio-controlled model and 1/11-scale spin-tunnel model.



NACA 64₂ - 415 AIRFOIL



NACA 64₂ - 415 AIRFOIL

MODIFIED TO INCORPORATE
DROOPED NOSE



NASA GA(W) - 1 AIRFOIL

Figure 4. Wing airfoil sections for NASA radio-controlled low-wing model No. 1.

ORIGINAL PAGE IS
OF POOR QUALITY

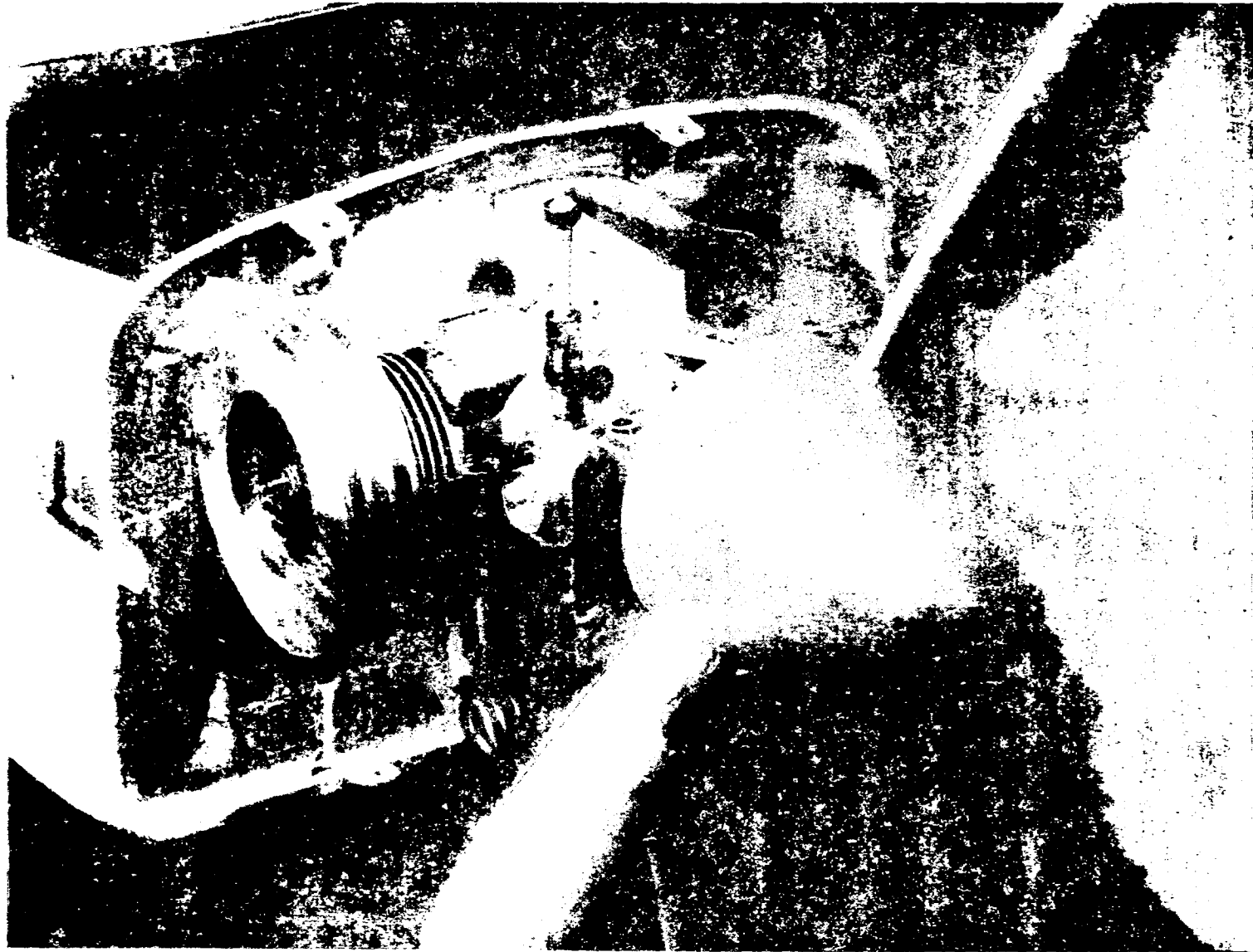
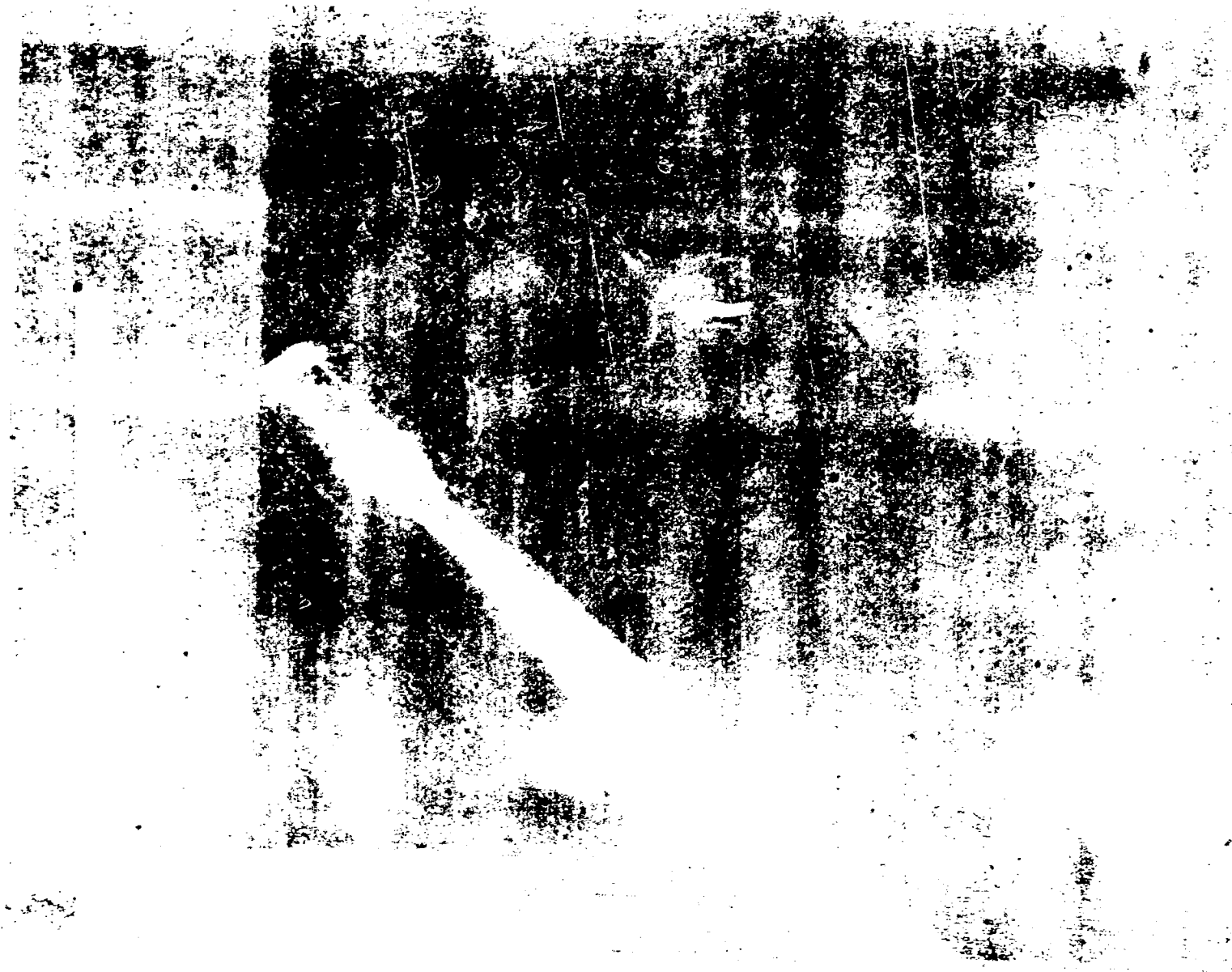

Figure 5. Model engine with heat-sink (aluminum fins) attached.

Figure 6. Spin-recovery parachute system used on NASA radio-controlled low-wing model No. 1.





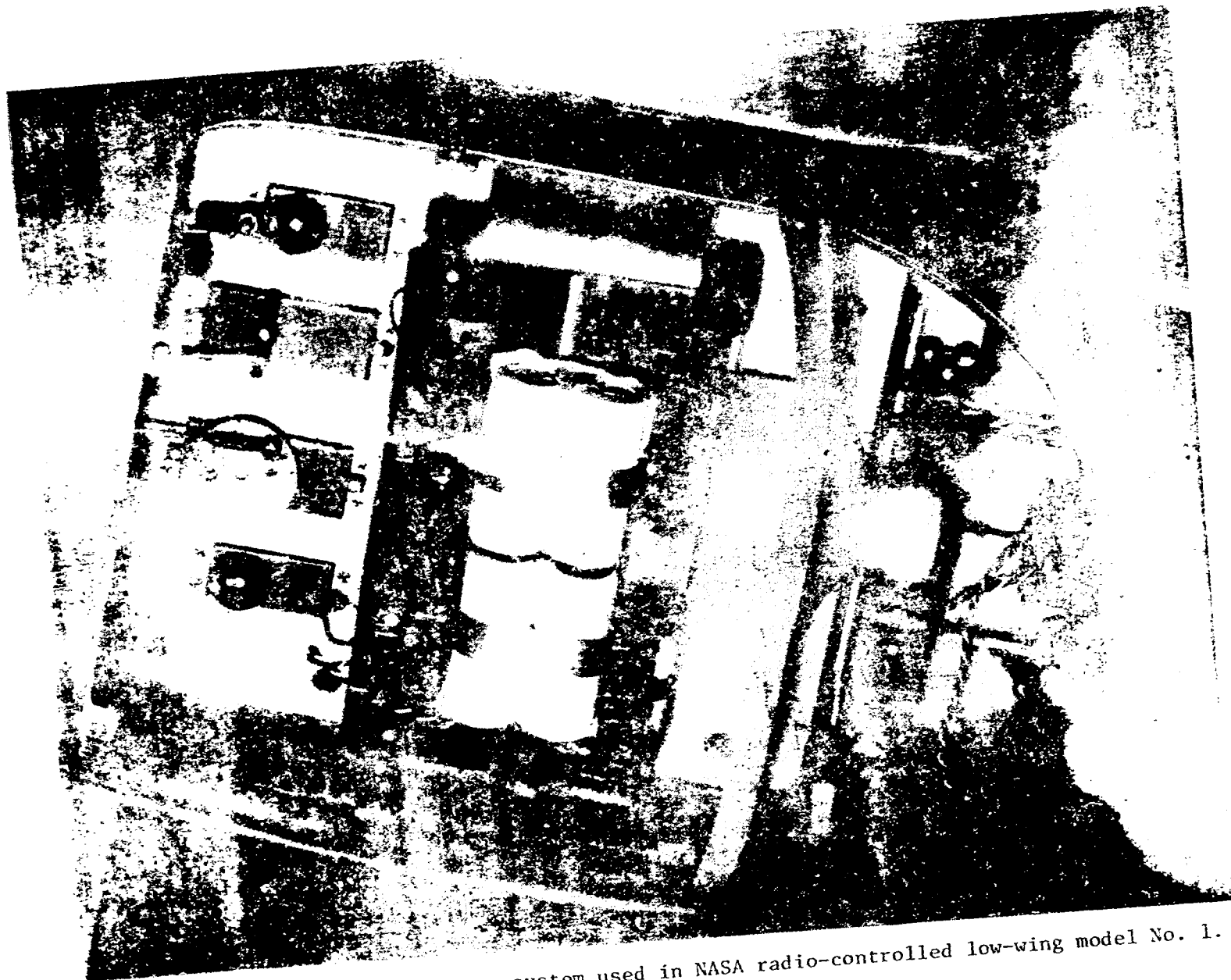

Figure 8. Seven-channel telemetry system used in NASA radio-controlled low-wing model No. 1.

ORIGINAL PAGE IS
POOR QUALITY

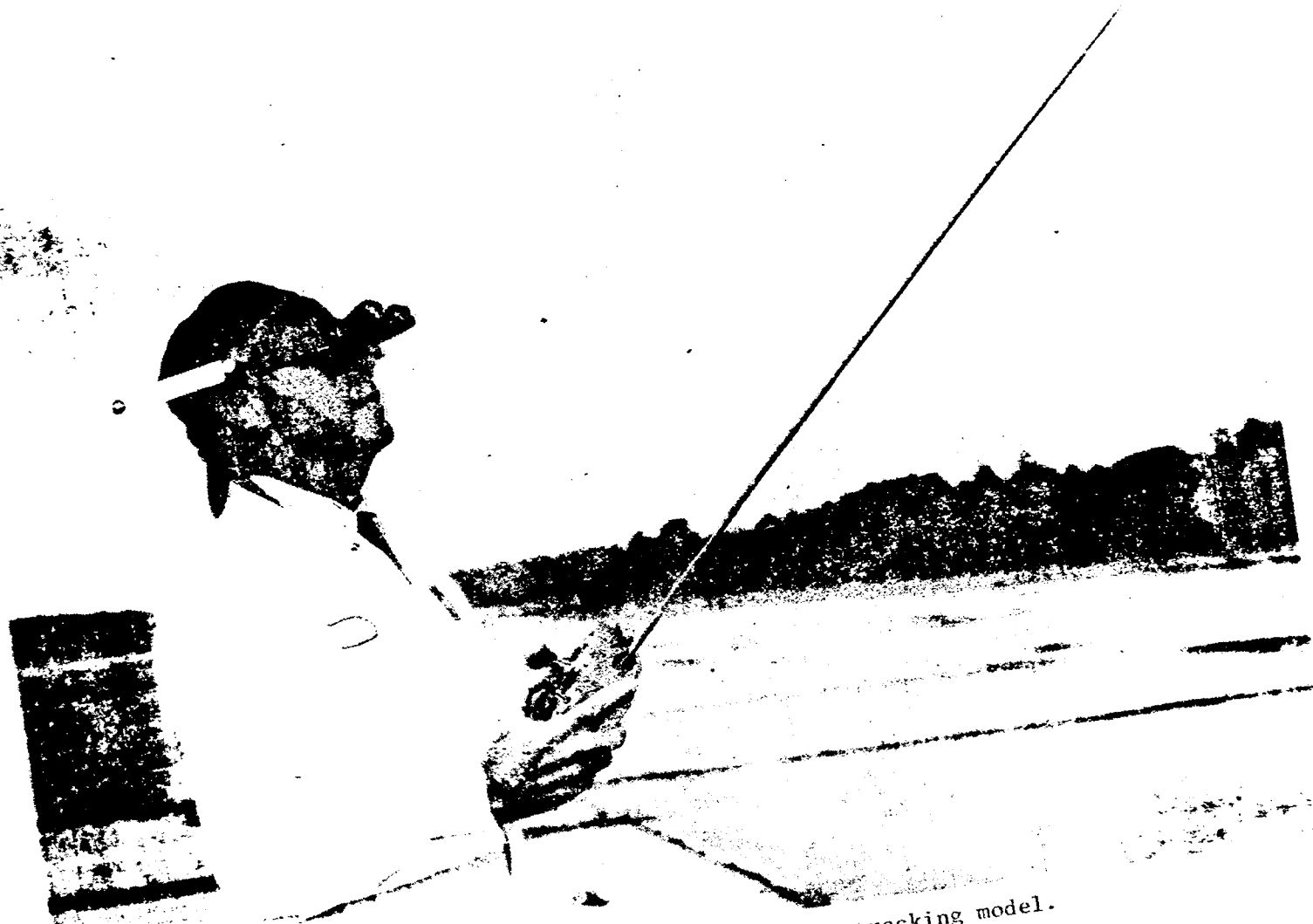
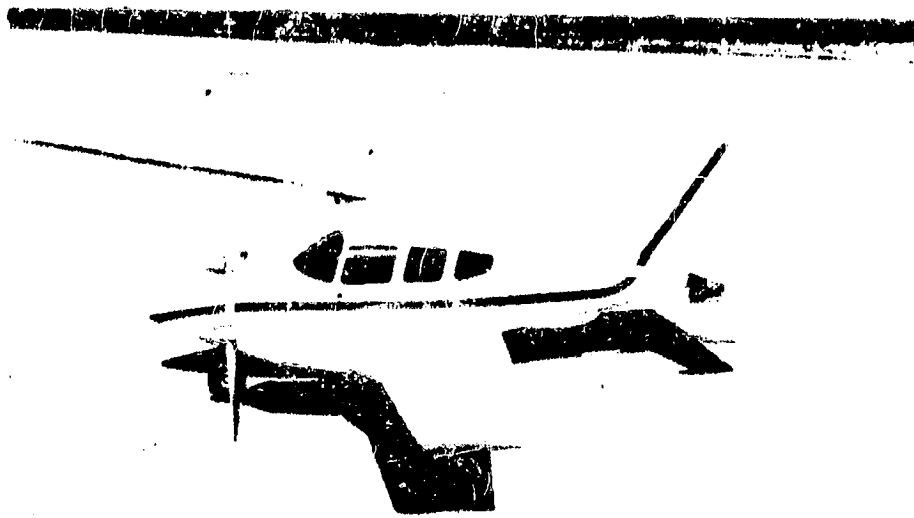

Figure 9. Head-mounted binoculars for tracking model.



Figure 10. NASA manual tracking system for photographing radio-controlled models.



(a) Radio-controlled model ready for flight.

Figure 11. Piper radio-controlled model and flight crew.



(b) Model, control boxes, and flight crew. Left to right: G. Wilson, Jr., J. Jackson, J. Brown, and D. Roemer.

Figure 11. Concluded.

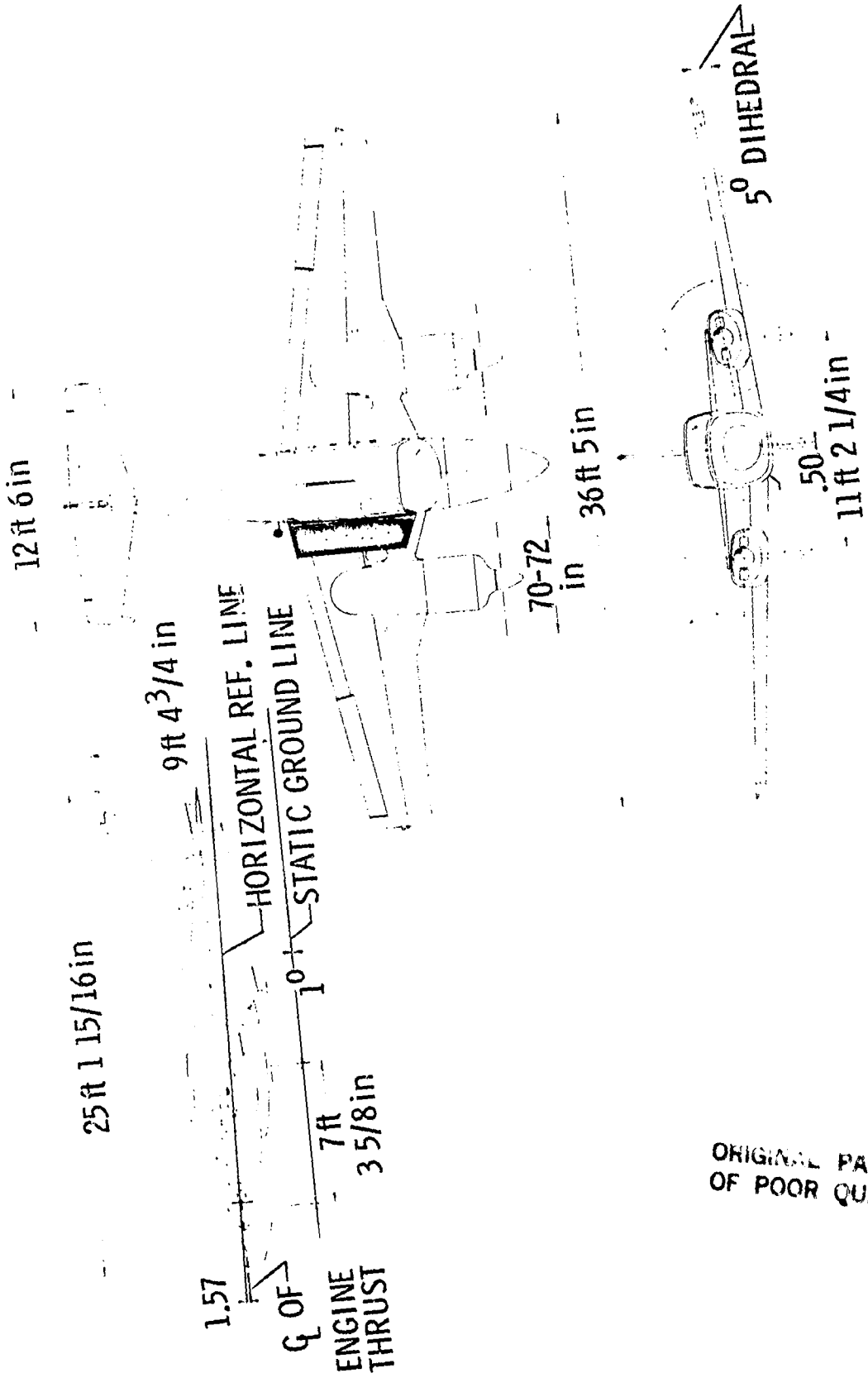
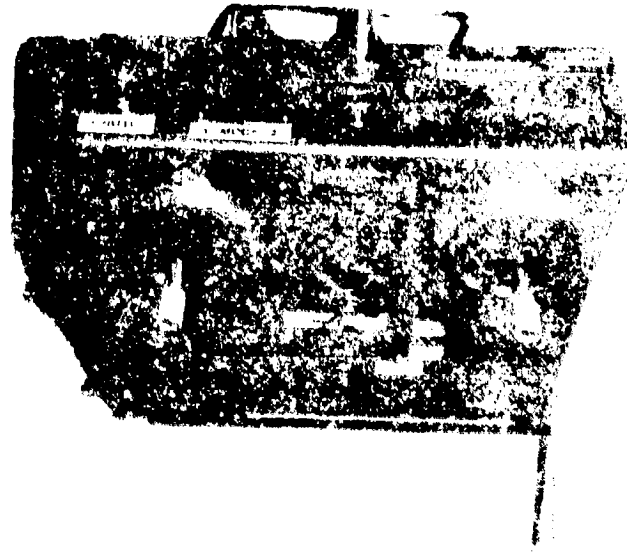

Figure 12. Three-view drawing of Piper aircraft.

ORIGINAL PAGE IS
OF POOR QUALITY



(a) Transmitter and primary control box.

Figure 13. Radio-control equipment.

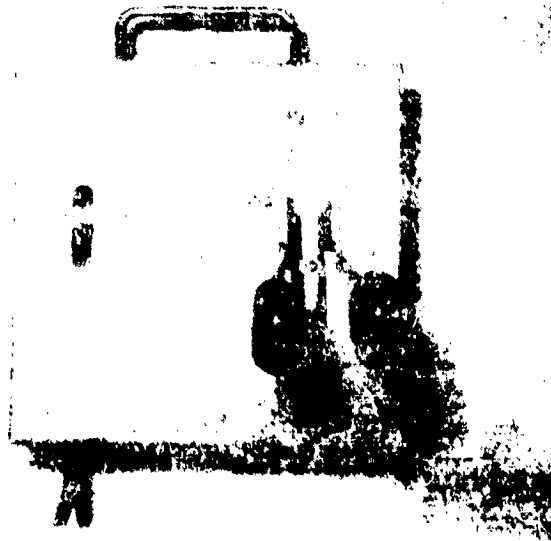

(b) Secondary control box with throttle and elevator controls.

Figure 13. (continued)

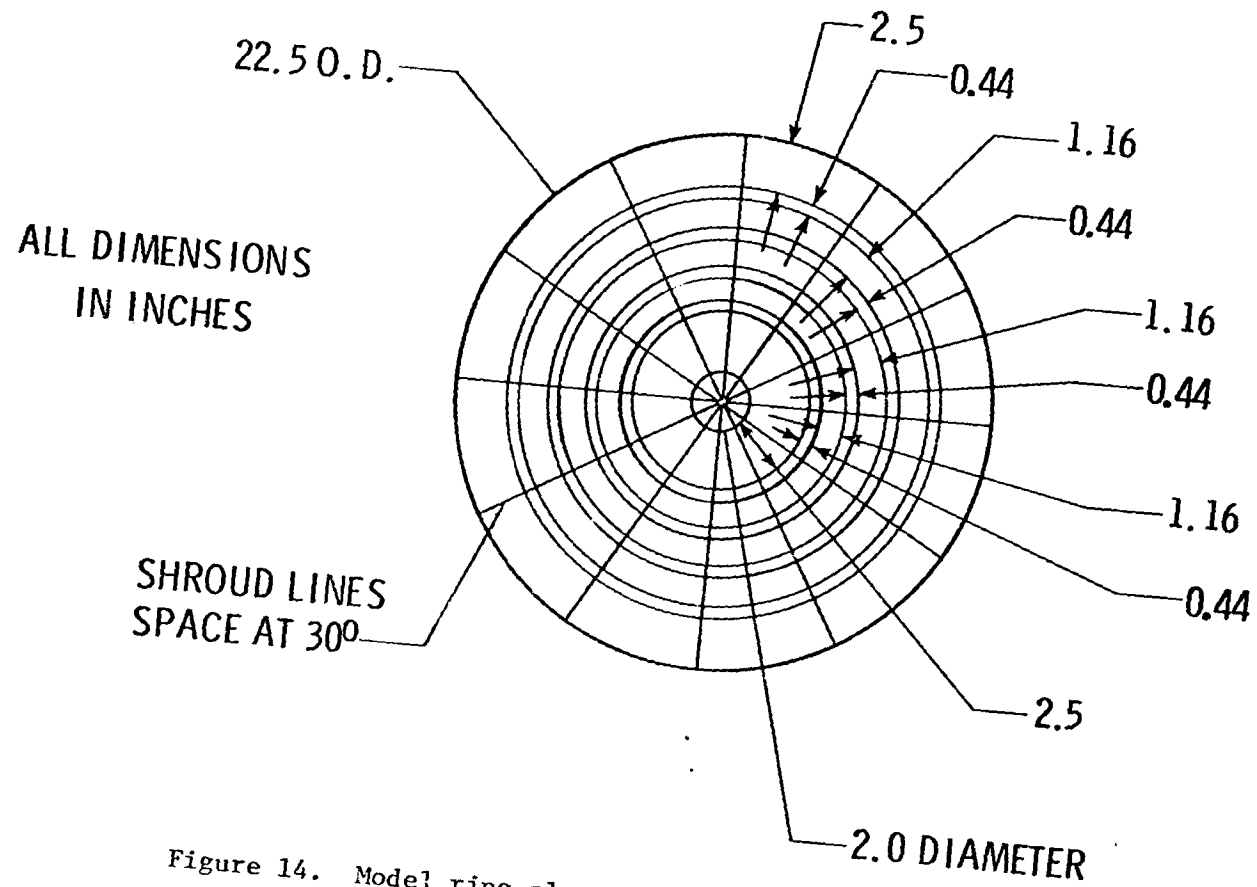

Figure 14. Model ring slot parachute with dimensions.

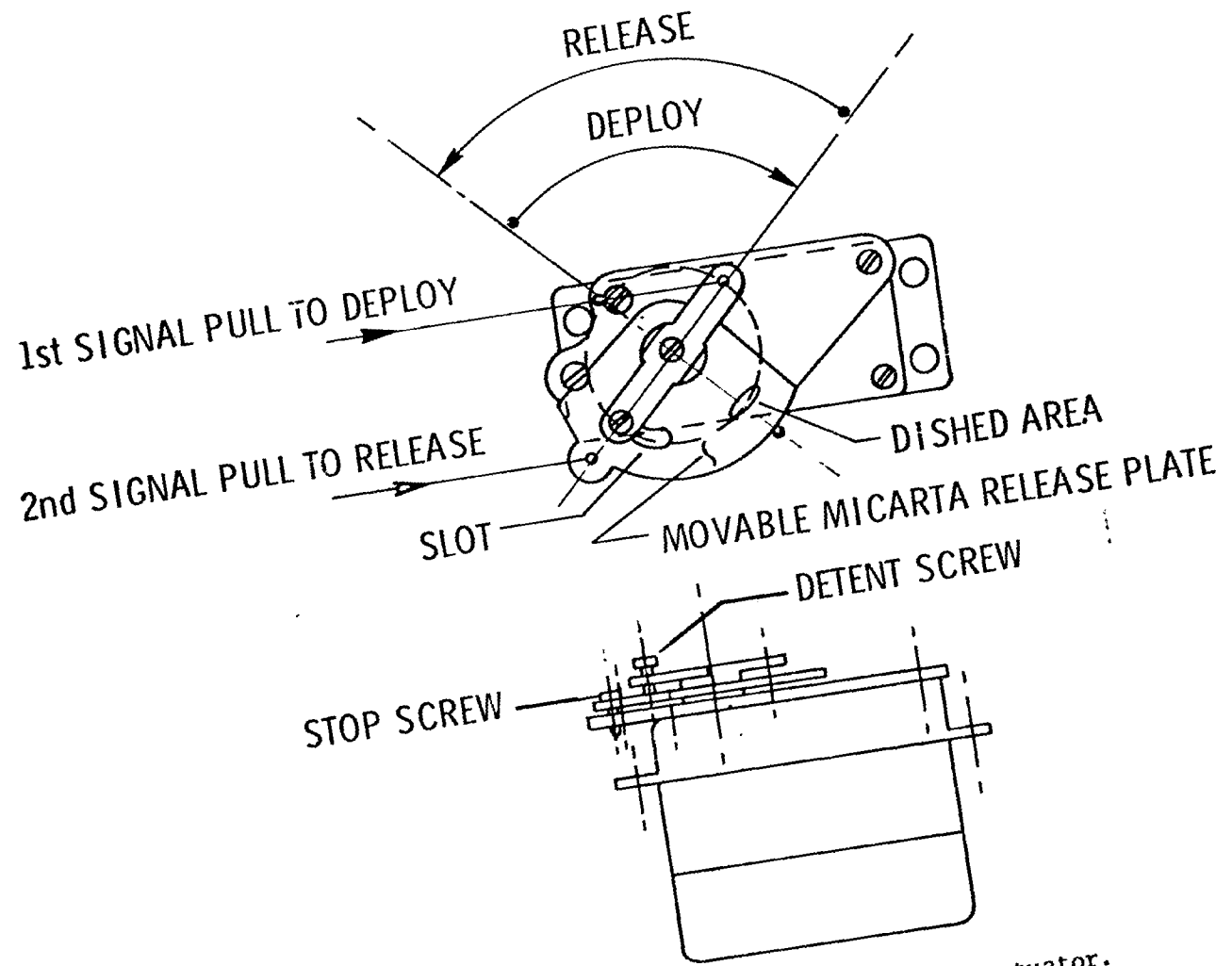

Figure 15. Servo parachute deployment-release actuator.

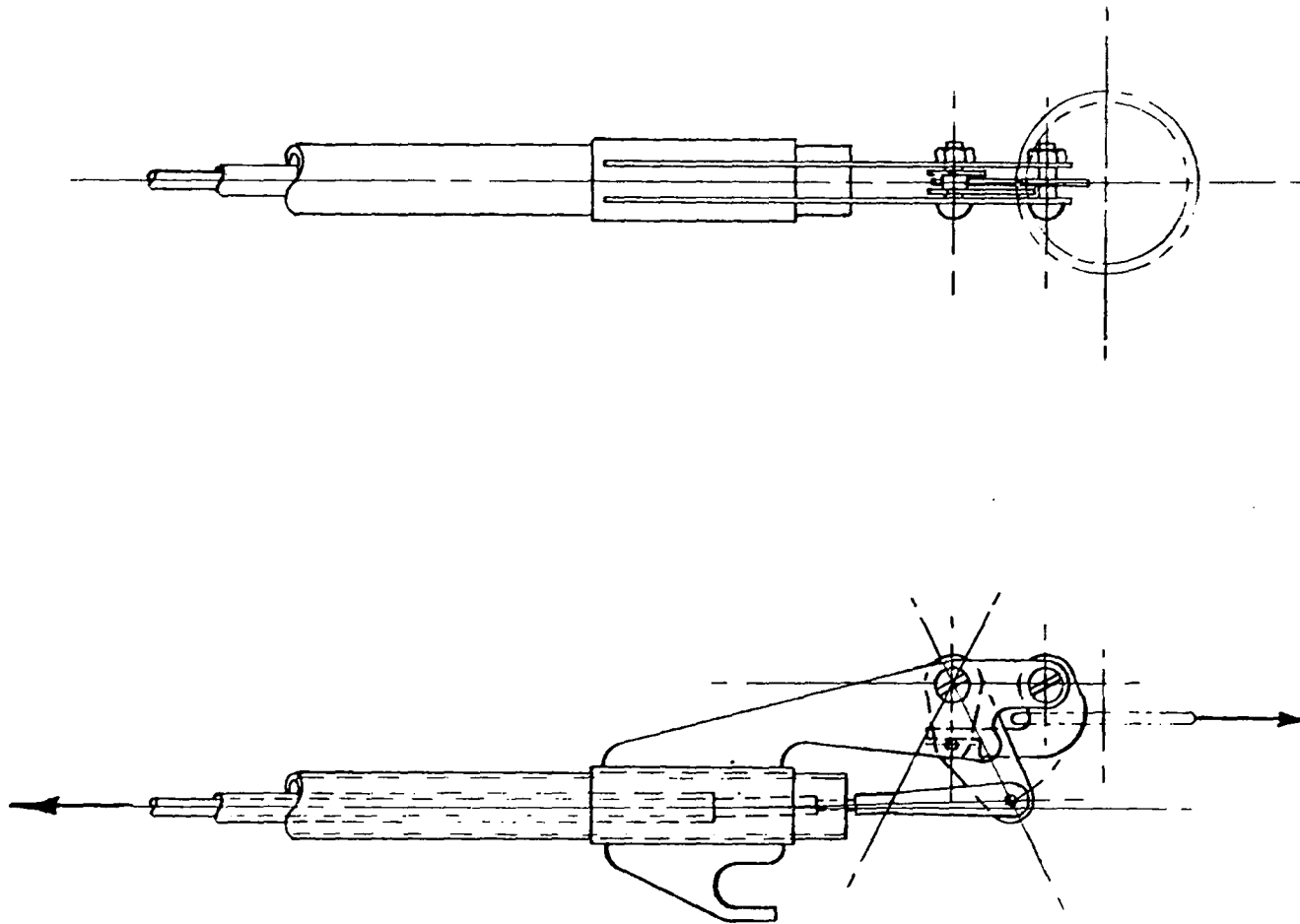

Figure 16. Parachute release mechanism.

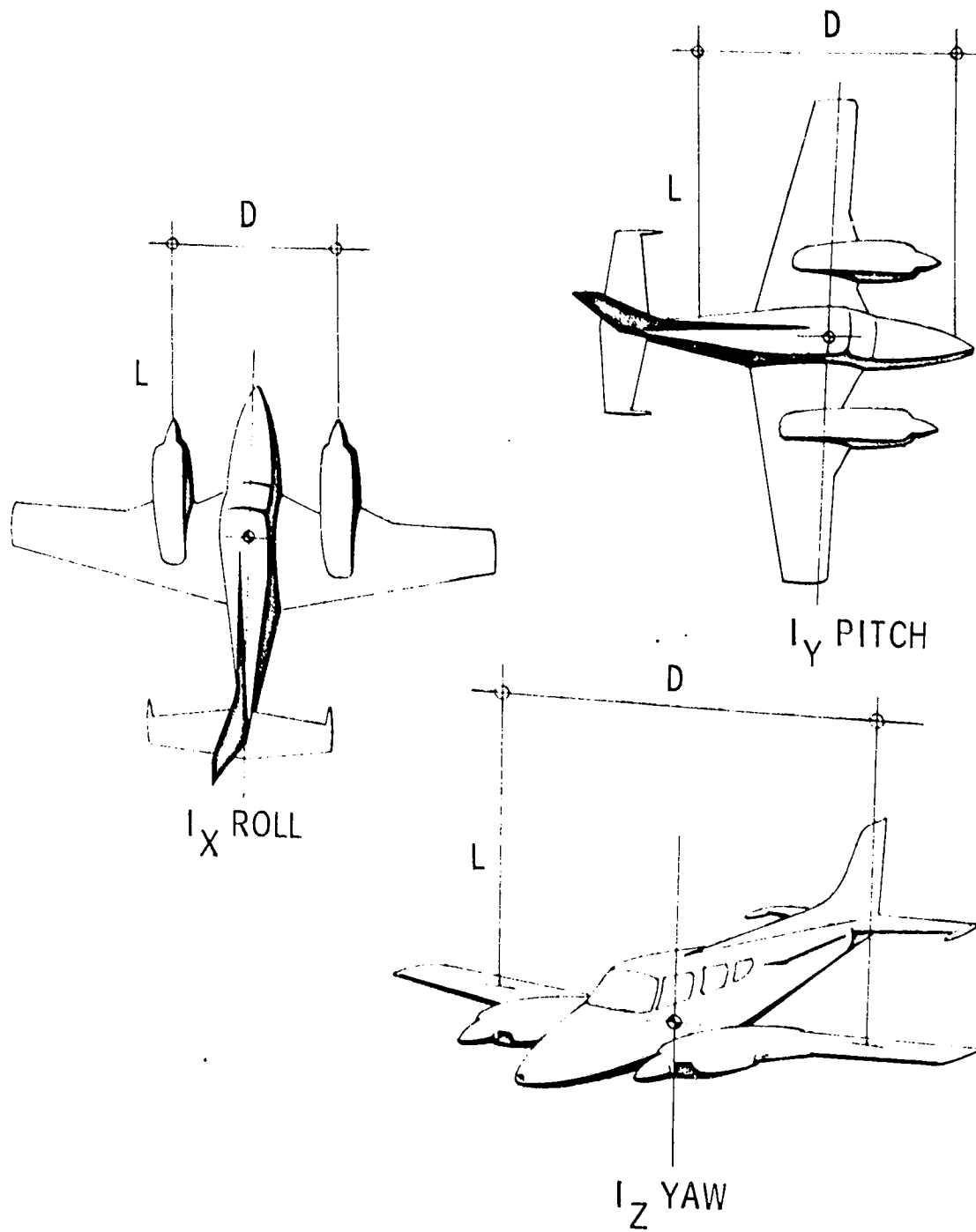

Figure 17. Bifilar swinging method to determine inertial properties.

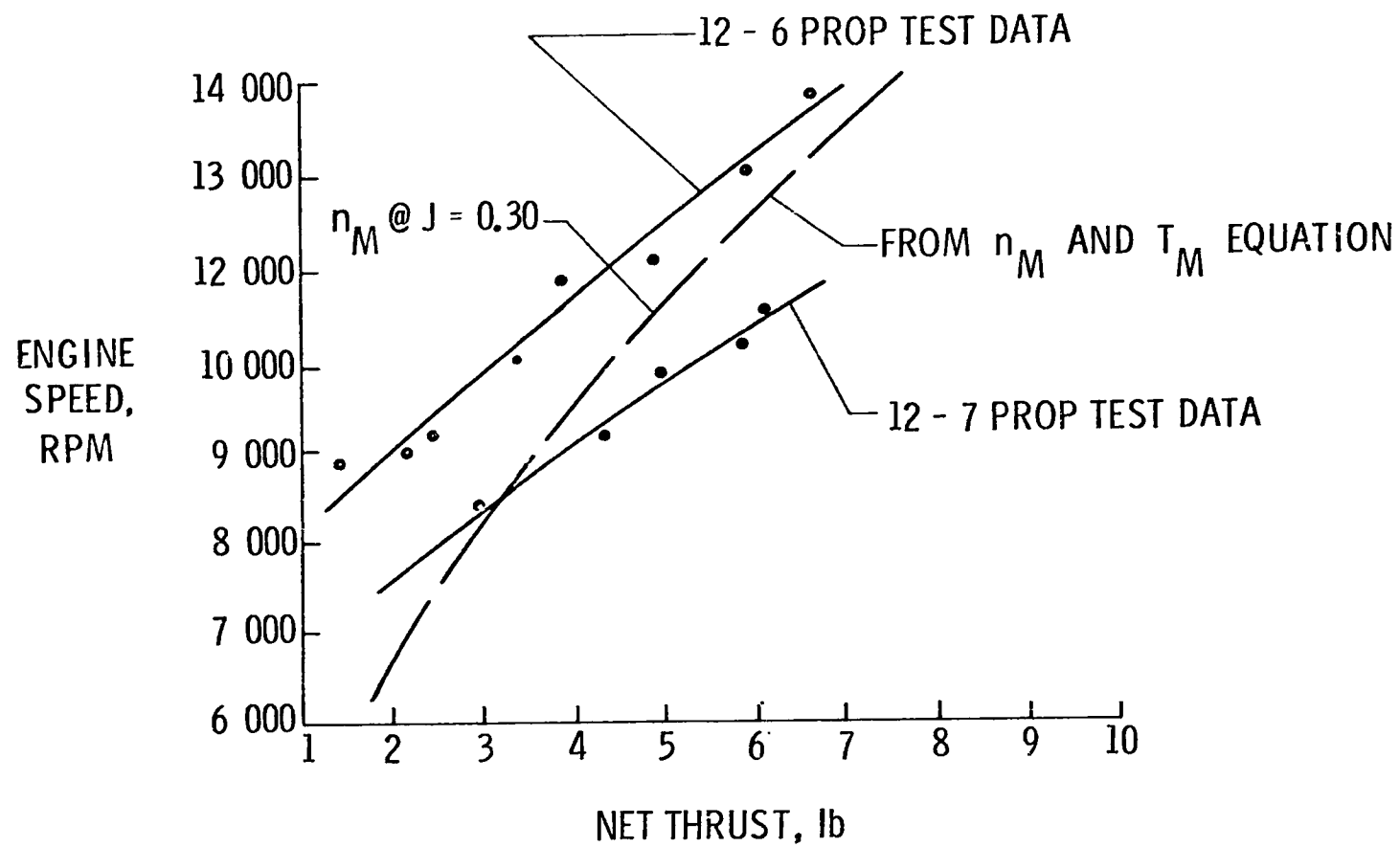

Figure 18. Engine speed (n_M) versus net thrust (T_M).

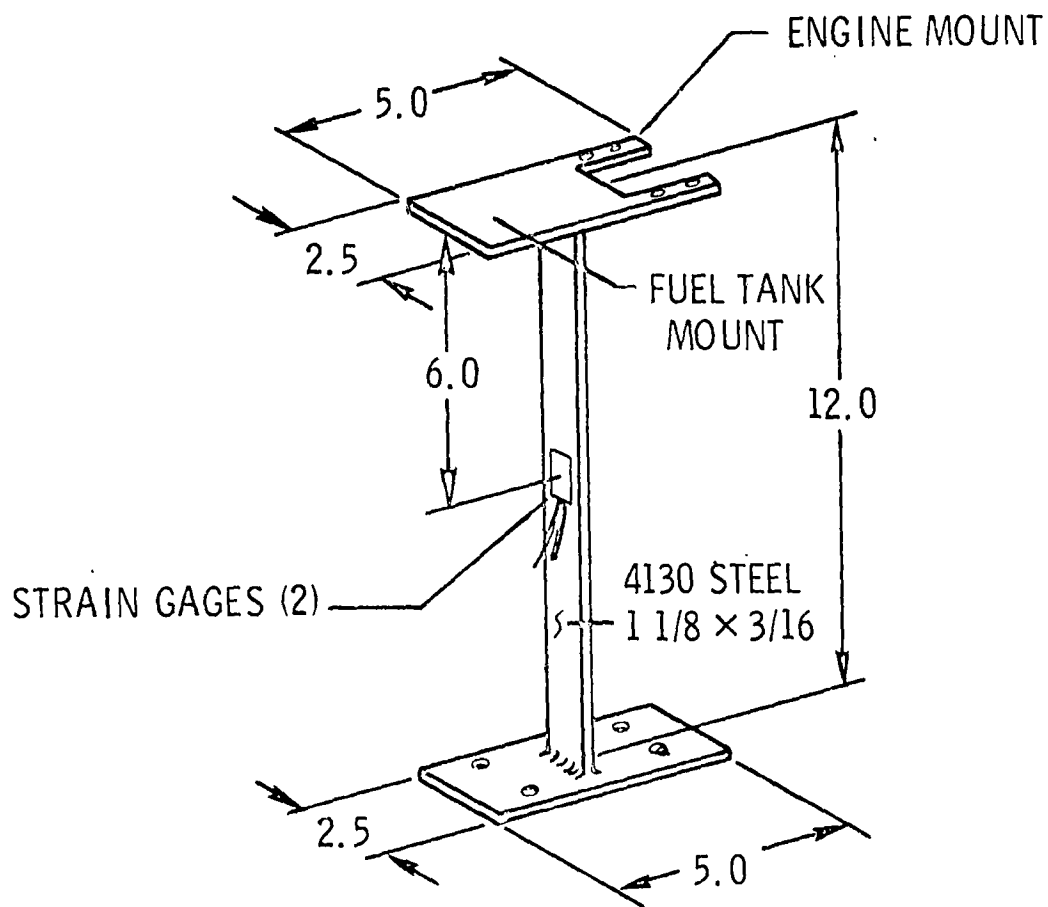

Figure 19. Thrust test stand. All dimensions are in inches.