

 Open access • Journal Article • DOI:10.1109/TIM.1969.4313796

Radiometric Evaluation of Antenna-Feed Component Losses — [Source link](#)

C. T. Stelzried, T.Y. Otoshi

Published on: 01 Sep 1969 - IEEE Transactions on Instrumentation and Measurement (IEEE)

Topics: Antenna feed, Noise temperature, Noise measurement, Background noise and Transmission loss

Related papers:

- [The Effect of Mismatched Components on Microwave Noise-Temperature Calibrations](#)
- [Calibration of antenna factor at a ground screen field site using an automatic network analyzer](#)
- [A 4-GHz band low-noise measurement system](#)
- [Hot and Cold Body Reference Noise Generators from 0 to 40 GHz](#)
- [A simple method of removing receiver noise from microwave noise measurements](#)

Share this paper:    

View more about this paper here: <https://typeset.io/papers/radiometric-evaluation-of-antenna-feed-component-losses-1qxo2joghz>

NASA TECH BRIEF



NASA Tech Briefs announce new technology derived from the U.S. space program. They are issued to encourage commercial application. Tech Briefs are available on a subscription basis from the Clearinghouse for Federal Scientific and Technical Information, Springfield, Virginia 22151. Requests for individual copies or questions relating to the Tech Brief program may be directed to the Technology Utilization Division, NASA, Code UT, Washington, D.C. 20546.

Radiometric Evaluation of Antenna-Feed Component Losses

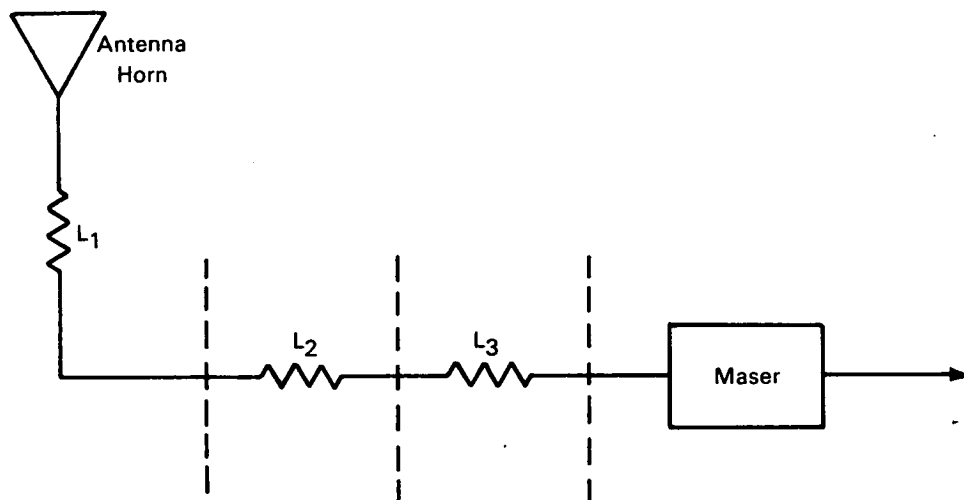

Simplified Antenna Network

Low noise antenna networks are frequently used in communications systems which measure atmospheric and cosmic background noise at microwave frequencies. Most of these applications require precise knowledge of the antenna line-loss between the antenna aperture and the receiver input port.

The determination of this portion of line-loss permits a precise calculation of the antenna noise-temperature component (operating noise-temperature) which is due to the external environment. High calibration accuracy is required since an uncertainty of 0.01 db in the dissipative line-loss corresponds to about 0.67°K uncertainty of antenna noise-temperature.

Although most sections of an antenna line can usually be evaluated by direct insertion-loss measurements or by theoretical calculations, the section which

contains the antenna-feed component (mode generator and polarizer) is difficult to calibrate because more than one waveguide mode is propagated and the field is circularly polarized.

A radiometric method has been developed to calibrate accurately the principal line sections of an antenna shown in the figure. The first line section is the feed horn having a loss factor, L_1 , that is easily calculated; the second line section contains the waveguide components having the unknown loss factor, L_2 ; the third line section contains single-mode waveguide components with a loss factor, L_3 , that can be calibrated by direct insertion-loss measurements. The radiometric method consists of measuring the operating noise-temperature with the normal feed components installed; these components are then replaced with a dominant-mode waveguide section having

(continued overleaf)

a known loss factor. The operating noise-temperature is measured again, and with the addition of several approximations based on theoretical considerations, the loss factor can be calculated:

One of the main advantages of this radiometric method is that precise knowledge of the absolute antenna temperature is not required. Error analysis calculations indicate that a fairly large error in the antenna noise-temperature, defined at the antenna aperture, has a negligible effect on the calibration accuracy. A combination of the individual probable errors, assuming they are uncorrelated, results in a total probable error for the line-loss of approximately 0.0016 db. The largest source of error in the calibration originates from mismatches between individual components.

Note:

Requests for further information may be directed to:
Technology Utilization Officer
NASA Pasadena Office
4800 Oak Grove Drive
Pasadena, California 91103
Reference: TSP70-10344

Patent status:

Inquiries about obtaining rights for the commercial use of this invention may be made to NASA, Code GP, Washington, D.C. 20546.

Source: C. T. Stelzried and T. Y. Otoshi of
Jet Propulsion Laboratory
under contract to
NASA Pasadena Office
(NPO-11238)