

<https://helda.helsinki.fi>

Rare coding variants in genes encoding GABA(A) receptors in genetic generalised epilepsies : an exome-based case-control study

EPIASURE Consortium

2018-08

EPIASURE Consortium , EuroEPINOMICS-CoGIE Consortium & EpiPGX Consortium 2018 , ' Rare coding variants in genes encoding GABA(A) receptors in genetic generalised epilepsies : an exome-based case-control study ' , Lancet Neurology , vol. 17 , no. 8 , pp. 699-708 . [https://doi.org/10.1016/S1474-4422\(18\)30215-1](https://doi.org/10.1016/S1474-4422(18)30215-1)

<http://hdl.handle.net/10138/309565>

[https://doi.org/10.1016/S1474-4422\(18\)30215-1](https://doi.org/10.1016/S1474-4422(18)30215-1)

cc_by_nc_nd

acceptedVersion

Downloaded from Helda, University of Helsinki institutional repository.

This is an electronic reprint of the original article.

This reprint may differ from the original in pagination and typographic detail.

Please cite the original version.

Rare coding variants in GABA_A receptor encoding genes in genetic generalized epilepsies: an exome-based case-control study

Patrick May, PhD^{#1}, Simon Girard, PhD, Prof^{#2}, Merle Harrer, MSc^{#3}, Dheeraj R. Bobbili, PhD^{#1}, Julian Schubert, PhD^{#3,4}, Stefan Wolking, MD^{#3}, Felicitas Becker^{3,5}, Pamela Lachance-Touchette, PhD⁶, Caroline Meloche, MSc⁶, Micheline Gravel, MSc⁶, Cristina E. Niturad, PhD³, Julia Knaus, MD³, Carolien De Kovel, PhD⁷, Mohamad Toliat, PhD⁴, Anne Polvi, PhD⁸, Michele Iacomino, PhD⁹, Rosa Guerrero-López, PhD¹⁰, Stéphanie Baulac, PhD¹¹, Carla Marini, MD, PhD¹², Holger Thiele, MD⁴, Janine Altmüller, MD^{4,13}, Kamel Jabbari, PhD⁴, Ann-Kathrin Ruppert, PhD⁴, Wiktor Jurkowski, PhD^{1,14}, Dennis Lal, PhD^{4,15,16,17,18,19}, Raffaella Rusconi, PhD²⁰, Sandrine Cestèle, PhD²⁰, Benedetta Terragni, PhD²¹, Ian D. Coombs, PhD²², Christopher A. Reid, PhD²³, Pasquale Striano, MD, PhD, Prof²⁴, Hande Caglayan, MD, Prof^{25,26}, Auli Siren, MD, PhD^{8,27}, Kate Everett, PhD²⁸, Rikke S. Møller, PhD, Prof^{29,30}, Helle Hjalgrim, MD, PhD, Prof^{29,30}, Hiltrud Muhle, MD³¹, Ingo Helbig, MD, Prof^{31,32}, Wolfram S. Kunz, PhD, Prof³³, Yvonne G. Weber, MD, Prof³, Sarah Weckhuysen, MD, PhD, Prof^{34,35,36}, Peter De Jonghe, MD, PhD, Prof^{34,35,36}, Sanjay M. Sisodiya, PhD, FRCP, Prof^{37,38}, Rima Nabhout, MD, PhD, Prof^{39,40,41,42}, Silvana Franceschetti, MD, PhD, Prof²¹, Antonietta Coppola, MD, PhD⁴³, Maria S. Vari, MD²⁴, Dorothee Kasteleijn-Nolst Trenité, MD, PhD⁷, Betul Baykan, MD, Prof⁴⁴, Ugur Ozbek, PhD, Prof⁴⁵, Nerses Bebek, MD, Prof⁴⁴, Karl M. Klein, MD, PhD⁴⁶, Felix Rosenow, MD, Prof⁴⁶, Dang K. Nguyen, MD, PhD⁴⁷, François Dubeau, MD⁴⁸, Lionel Carmant, MD⁴⁹, Anne Lortie, MD⁴⁹, Richard Desbiens, MD⁵⁰, Jean-François Clément, PhD⁵¹, Cécile Cieuta-Walti, MD⁵², Graeme J. Sills, PhD⁵³, Pauls Auce, MD, PhD⁵³, Ben Francis, PhD⁵⁴, Michael R. Johnson, DPhil, FRCP⁵⁵, Anthony G. Marson, MD, FRCP⁵⁵, Bianca Berghuis, MD⁵⁶, Josemir W. Sander, PhD, FRCP, Prof^{37,38,56}, Andreja Avbersek, MD³⁷, Mark McCormack, PhD^{7,57}, Gianpiero L. Cavalleri, PhD^{57,58}, Norman Delanty, FRCP^{57,58}, Chantal Depondt, MD, PhD^{59,60}, Martin Krenn, MD⁶¹, Fritz Zimprich, MD, PhD⁶¹, Sarah Peter, MSc¹, Marina Nikanorova, MD²⁹, Robert Kraaij, PhD⁶², Jeroen van Rooij, BSc⁶², Epicure Consortium, EuroEPINOMICS CoGIE Consortium, EpiPGX Consortium, Rudi Balling, PhD, Prof¹, M. Arfan Ikram, MD, PhD, Prof⁶³, André G. Uitterlinden, PhD, Prof⁶², Giuliano Avanzini, MD, Prof²¹, Stephanie Schorge, PhD³⁷, Steven Petrou, PhD, Prof²³, Massimo Mantegazza, PhD²⁰, Thomas Sander, MD⁴, Eric LeGuern, MD, PhD, Prof¹, Jose M. Serratos, MD, PhD, Prof¹⁰, Bobby P.C. Koeleman, PhD, Prof⁷, Aarno Palotie, MD, PhD, Prof^{15,64}, Anna-Elina Lehesjoki, MD, PhD, Prof^{8,65}, Michael Nothnagel, PhD, Prof⁴, Peter Nürnberg, PhD, Prof^{4,13,66}, Snezana Maljevic, PhD^{83,23}, Federico Zara, PhD, Prof⁸⁹, Patrick Cossette, MD, PhD, Prof⁸⁶, Roland Krause, PhD⁸¹, Holger Lerche, MD, Prof^{8*3}

[#]equally contributing first authors

[§]equally contributing PIs

*corresponding author

1 Luxembourg Centre for Systems Biomedicine, University of Luxembourg, Esch-sur-Alzette, Luxembourg

2 Université du Québec à Chicoutimi, Département des sciences fondamentales, Chicoutimi, Canada

- 3 University of Tübingen, Department of Neurology and Epileptology, Hertie Institute for Clinical Brain Research, Tübingen, Germany
- 4 Cologne Center for Genomics, University of Cologne, Cologne, Germany
- 5 Department of Neurology, University of Ulm, Ulm, Germany
- 6 Centre de recherche du Centre Hospitalier Universitaire de l'Université de Montréal, Montréal, Canada
- 7 Department of Genetics, UMC Utrecht, Utrecht, Netherlands
- 8 Folkhälsan Institute of Genetics, Helsinki, Finland
- 9 Laboratory of Neurogenetics and Neuroscience, Institute G. Gaslini, Genova, Italy
- 10 Laboratory of Neurology, Instituto Investigación Sanitaria Fundación Jiménez Díaz and Centro de Investigación Biomédica en Red de Enfermedades Raras, Madrid, Spain
- 11 Institut du Cerveau et de la Moelle épinière, ICM, Inserm U 1127, CNRS UMR 7225, Sorbonne Université, AP-HP, Hôpital Pitié-Salpêtrière, Department of Genetics , F-75013 Paris, France
- 12 Pediatric neurology unit, Meyer Children's Hospital Florence, Italy
- 13 Center for Molecular Medicine Cologne, University of Cologne, Cologne, Germany
- 14 The Genome Analysis Centre, Norwich, UK
- 15 Stanley Center for Psychiatric Research, Broad Institute of MIT and Harvard, Cambridge, MA, USA
- 16 Psychiatric and Neurodevelopmental Genetics Unit, Massachusetts General Hospital and Harvard Medical School, Boston, MA, USA
- 17 Program in Medical and Population Genetics, Broad Institute of MIT and Harvard, Cambridge, MA, USA
- 18 Epilepsy Center, Neurological Institute, Cleveland Clinic, Cleveland, OH, USA
- 19 Genomic Medicine Institute, Lerner Research Institute Cleveland Clinic, Cleveland, OH, USA
- 20 Université Côte d'Azur, CNRS UMR7275, Institute of Molecular and Cellular Pharmacology, Laboratory of Excellence Ion Channel Science and Therapeutics, Valbonne-Sophia Antipolis, France
- 21 Department of Neurophysiology and Epilepsy Unit, Besta Neurological Institute, Milan, Italy
- 22 Department of Neuroscience, Physiology and Pharmacology, University College London, London, UK
- 23 Ion Channels & Disease Group, Epilepsy Division, The Florey Institute of Neuroscience and Mental Health, Parkville, Victoria, Australia
- 24 Pediatric Neurology and Muscular Diseases Unit, DINOGMI-Department of Neurosciences, Rehabilitation, Ophthalmology, Genetics, Maternal and Child Health, University of Genova, Institute "G. Gaslini", Genova, Italy
- 25 Department of Molecular Biology and Genetics, Boğaziçi University, Istanbul, Turkey
- 26 International Biomedicine and Genome Center, Dokuz Eylül University, Izmir, Turkey
- 27 Department of Pediatric Neurology, Kanta-Häme Central Hospital, Hämeenlinna, Finland
- 28 Cell Sciences and Genetics Research Centre, St. George's University of London, London, UK
- 29 The Danish Epilepsy Centre, Dianalund, Denmark
- 30 Institute for Regional Health Research, University of Southern Denmark, Odense, Denmark
- 31 Department of Neuropediatrics, University Medical Center Schleswig-Holstein, Christian-Albrechts University, Kiel, Germany
- 32 Division of Neurology, The Children's Hospital of Philadelphia, Philadelphia, USA

- 33 Department of Epileptology and Life & Brain Center, University of Bonn, Bonn, Germany
- 34 Division of Neurology, Antwerp University Hospital, Antwerp, Belgium
- 35 Neurogenetics Group, Center for Molecular Neurology, VIB, Antwerp, Belgium
- 36 Laboratory of Neurogenetics, Institute Born-Bunge, University of Antwerp, Antwerp, Belgium
- 37 Department of Clinical and Experimental Epilepsy, Institute of Neurology, University College London, London, UK
- 38 Chalfont Centre for Epilepsy, Chalfont St Peter, Buckinghamshire, UK
- 39 INSERM U1129, Paris, France
- 40 Paris Descartes University, Sorbonne Paris Cité, Paris, France
- 41 CEA, Gif sur Yvette, France
- 42 Department of Pediatric Neurology, APHP, Necker-Enfants Malades Hospital, Imagine Institute, Paris, France
- 43 Department of Neuroscience, Reproductive and Odontostomatological Sciences, Federico II University, Napoli, Italy
- 44 Department of Neurology, Istanbul Faculty of Medicine, Istanbul University, Istanbul, Turkey
- 45 Department of Medical Genetics, School of Medicine, Institute of Health Sciences, Acibadem University, Istanbul, Turkey
- 46 Epilepsy Center Frankfurt Rhine-Main, Department of Neurology, Center of Neurology and Neurosurgery, University Hospital, Goethe-University, Frankfurt, Germany
- 47 Centre Hospitalier de l'Université de Montréal, Montréal, Canada
- 48 Montreal Neurological Hospital, Montréal, Canada
- 49 CHU Ste-Justine, Montréal, Canada
- 50 Centre Hospitalier Universitaire de l'Université Laval, Québec, Canada
- 51 Clinique de Neuro Rive-Sud, Longueuil, Canada
- 52 Centre Hospitalier Universitaire de l'Université de Sherbrooke, Sherbrooke, Canada
- 53 Department of Molecular and Clinical Pharmacology, University of Liverpool, Liverpool, UK
- 54 Department of Biostatistics, University of Liverpool, Liverpool, UK
- 55 Division of Brain Sciences, Imperial College Faculty of Medicine, London, UK
- 56 Stichting Epilepsie Instellingen Nederland (SEIN), Heemstede, Netherlands
- 57 Molecular and Cellular Therapeutics, Royal College of Surgeons in Ireland, Ireland
- 58 The FutureNeuro Research Centre, Dublin, Ireland
- 59 Laboratory of Experimental Neurology, Hôpital Erasme, Université Libre de Bruxelles, Brussels, Belgium
- 60 Department of Neurology, Hôpital Erasme, Université Libre de Bruxelles, Brussels, Belgium
- 61 Department of Neurology, Medical University of Vienna, Vienna, Austria
- 62 Department of Internal Medicine, Erasmus Medical Center, Rotterdam, Netherlands
- 63 Department of Epidemiology, Erasmus MC, Rotterdam, Netherlands
- 64 Institute for Molecular Medicine Finland, University of Helsinki, Helsinki, Finland
- 65 Neuroscience Center and Research Program for Molecular Neurology, University of Helsinki, Finland
- 66 Cologne Excellence Cluster on Cellular Stress Responses in Aging-Associated Diseases, University of Cologne, Cologne, Germany

Corresponding author:

Holger Lerche, MD
Department of Neurology and Epileptology
Hertie Institute for Clinical Brain Research
University of Tübingen
Hoppe-Seyler-Str. 3
72076 Tübingen
Germany
Tel.: +49-7071-29-80442
Fax: +49-7071-29-4488
e-mail: holger.lerche@uni-tuebingen.de

Summary

Background Generalized epilepsy with genetic etiology (GGE) is the most common type of inherited epilepsy characterized by absence, myoclonic and generalized tonic-clonic seizures typically occurring with generalized spike-and-wave discharges on electroencephalography. Despite a high concordance rate of 80% in monozygotic twins, the genetic background is still poorly understood.

Methods Cases included in the study were clinically evaluated for GGE. Whole-exome sequencing (WES) was performed for the discovery case cohort, the first validation case cohort and for two independent control cohorts. A second replication case cohort underwent targeted next-generation sequencing of the 19 known genes encoding subunits of GABA_A receptors and was compared to the respective GABA_A receptor variants of a third independent control cohort. Functional investigations were performed using automated two-microelectrode voltage clamping in *Xenopus* oocytes.

Findings Statistical comparison of 152 familial index cases with GGE in the discovery cohort to 549 ethnically matched controls suggested an enrichment of rare missense variants in the ensemble of GABA_A receptor encoding genes in cases. The enrichment for these genes could be validated in a second WES cohort of 357 sporadic and familial GGE cases and 1485 independent controls. Comparison of GABA_A receptor genes in a second independent replication cohort of 635 familial and sporadic GGE index cases, based on candidate-gene panel sequencing, to a third independent control cohort confirmed the overall enrichment of rare missense variants in cases. Functional studies for two selected genes (*GABRB2*, *GABRA5*) showed significant loss-of-function effects with reduced current amplitudes in four of seven tested variants compared to wild-type receptors.

Interpretation Our results suggest that functionally relevant variants in GABA_A receptor subunit encoding genes constitute a significant risk factor for GGE. This conclusion is based on an enrichment of rare variants in those genes in three independent case-control datasets and physiological studies revealing a loss of function for tested variants which are supposed to favor a neuronal disinhibition which is a well-known mechanism in epilepsy. We further show that examining the role of specific gene groups and pathways can be used to disentangle the complex genetic architecture of GGE.

Funding The study was supported by different national funding agencies in the frame of EuroEPINOMICS (a project of the European Science Foundation), by Epicure and EpiPGX (funded by the FP6 and FP7 programs of the European Commission), by Research Unit FOR2715 (funded by the DFG and the FNR), and by a couple of smaller grants from different bodies. More detailed information on the funding sources is given in the acknowledgements.

Research in context

Evidence before this study

Generalized epilepsies with genetic etiology (GGE) are a group of diseases with a complex inheritance, meaning that probably many common and rare genetic factors are involved in the etiology of the disease, the genetic architecture of which is still largely unknown. We searched the Pubmed database for articles published in English language with the search terms “Exome sequencing ion channels”, “exome sequencing genetic generalized epilepsy” or “exome sequencing idiopathic generalized epilepsy”, until May 30, 2017.”. At the time we conducted this study, there were only two studies which had performed targeted or whole-exome sequencing in smaller cohorts of subjects with GGE. Neither study detected significant differences in the burden of rare genetic variants in cases vs. controls. One study used a targeted Sanger sequencing approach in 237 ion channel genes in 152 cases vs. 139 normal controls. The other study applied whole exome sequencing to 118 subjects with juvenile myoclonic epilepsy and absence epilepsy, two of the main sub-phenotypes of GGE, and 242 controls. In a recent third study by the Epi4K and EP/GP consortia whole exomes of 640 subjects with GGE and 3877 controls were sequenced which showed that the rate of ultra-rare deleterious variants in a group of established epilepsy genes was significantly increased; no single gene showed a mutational burden in GGE.

Added value of this study

We have detected a difference between cases and controls in missense variants in a specific group of genes encoding all known GABA_A receptors. This finding is novel in the literature. We were able to reproduce this signal in two independent cohorts of cases in comparison to two independent control cohorts. We also demonstrate the functional relevance of some of the detected variants in two GABA_A receptor subunit genes that were so far not known to be associated with GGE or epilepsy. Our study therefore provides strong evidence that variation in GABA_A receptor encoding genes confers a genetic burden in GGE. It also points at the utility of burden analysis of sets of genes involved in specific physiological pathways in explaining the genetics behind the generalized epilepsies.

Implications of all the available evidence

The study by the Epi4K and EPGP consortia and our findings present the first evidence of a significant genetic burden in GGE compared to controls in ultra-rare variants affecting previously identified epilepsy genes or as suggested here in the specific gene group of the most important inhibitory receptors in the mammalian brain.

Introduction

Gene discovery in monogenetic diseases, including familial and severe epilepsy syndromes, has revealed a steadily increasing number of disease-causing genetic defects. Unraveling the genetic architecture of complex disorders has been more difficult. GGE comprises common epilepsies with generalized absence, myoclonic and tonic-clonic seizures¹. Its high heritability, as has been shown in twin studies². A few single nucleotide polymorphisms in genome-wide association studies and altered copy number variations have been the major common risk factors identified so far in GGE. These, however, only explain a small part of the high heritability. Single gene defects in larger families with autosomal dominantly inherited GGE have been identified as disease-causing, e.g. in *GABRA1* or *GABRG2* encoding subunits of GABA_A receptors³⁻⁵, or in *SLC2A1* encoding the glucose transporter type 1^{6,7}. Early sequencing-based candidate-gene or whole-exome sequencing (WES) studies did not reveal a significant burden of mutations in single genes or groups of genes thus far^{8,9}. A recent study has demonstrated mutational burden of ultra-rare variants in gene-sets related to epilepsy¹⁰.

We set out to investigate the burden of rare genetic variants in familial GGE by first testing all genes in a hypothesis-free approach, and second hypothesis-driven disease-relevant gene-sets. Significant findings were validated and replicated in additional cohorts and functional studies performed for selected variants. Our results indicate a genetic burden in GGE across a gene-set encoding all GABA_A receptor subunits.

Methods

Participants

GGE diagnoses in this study were based on clinical grounds, i.e. on clinical interview, neurological examination, EEG recordings and available imaging data, by experienced epileptologists according to ILAE classifications at the time of diagnosis and recruitment. All patients fulfill the criteria of the latest version from 2017¹. Written informed consent was obtained from all subjects or their relatives. The study was approved by local Ethical Committees. One affected individual of each family was selected for sequencing.

We used three different GGE case cohorts and three independent control cohorts, all of European descent, for our sequencing studies. The GGE diagnoses included mainly the classical four phenotypes of childhood or juvenile absence epilepsy (CAE, JAE), juvenile myoclonic epilepsy (JME), or GGE with generalized tonic-clonic seizures alone (EGTC); we included few cases with early-onset absence epilepsy (EOAE, defined as beginning below three years of age), epilepsy with myoclonic absences (EMA) and up to 30% unclassified GGE, since these entities in our view are close to classical GGE. For EOAE it has been recently suggested by a large study that it is likely genetically similar to classical CAE¹¹, EMA may also have genetic overlaps with GGE¹² and we often find in family studies both well classified and unclassified GGE cases in the same

pedigrees (see appendix for detailed phenotypes in all cohorts). The first, discovery WES case cohort included 152 subjects (after quality control (QC)) with GGE from multiplex families, collected by the Epicure and the EuroEPINOMICS-CoGIE consortia. The majority of cases (n=143, 94%) derived from multiplex families with at least two affected family members, thereof 76 families with three or more affected members (table S1). The second, validation cohort consisted of 357 GGE cases (after QC) collected by the EpiPGX consortium. 92 cases (26%) derived from families with at least two affected members. 131 cases were sporadic, for the remaining 134 cases, familial history was not known (table S2). Two independent WES control cohorts were obtained from two separately sequenced cohorts (termed A and B) from the Rotterdam study^{13,14} which were matched for ethnicity (see appendix). All controls were at least 55 years old or older and checked for several neurological conditions at baseline. As GGE is a disease with typical onset from childhood to adolescence, it is unlikely that people at this age could still develop GGE. Controls were chosen so that the distribution of sexes was similar to according cases. The third, replication cohort, was collected in Quebec, Canada, and in Europe for GABA_A receptor gene panel sequencing (table S3). 154 cases (24%) were familial with at least 2 affected family members, for 51 there was a positive family history of epilepsy, and 426 cases were sporadic. A third independent set of controls (cohort C) was obtained from the UK10K project consortium¹⁵ (see appendix 4c). UK10K control samples were of self-reported European ethnicity and were processed to remove outlier samples (figures S6 and S7). A total of 639 ethnically matched individuals were selected from the control cohort C.

Procedures

For the discovery stage, paired-end WES of cases and controls (set A and B) was performed with the Illumina HiSeq 2000 using the EZ Human Exome Library v2.0 kit (NimbleGen, Madison, WI). Cases and controls were sequenced at different locations, cases at the Cologne Center for Genomics and the control cohort A in Rotterdam¹³. Sequencing adapters were trimmed and samples with <30X mean depth or <70% total exome coverage at 20X mean depth of coverage were excluded from further analysis. For the validation cohort, WES was performed at deCODE genetics (Iceland) on the Illumina HiSeq 2500 using the Nextera Rapid Capture Expanded Exome kit (Illumina). The Rotterdam control set B¹⁴ was sequenced as set A. Variant calling was performed by using the GATK¹⁶ best practices pipeline with the GRCh37 human reference genome (see appendix). To exclude low quality variants, we performed an additional filtering based on quality metrics of individual genotypes, using read depth and genotype quality as the filtering criteria. We excluded any variant position with mean depth of <10 in either cases or controls. For all WES samples, the same exome regions file from the EZ Human Exome Library v2.0 kit was used. Only samples with more than 30X mean coverage or more than 70% of the exome intervals covered by at least 20x mean coverage were included for analysis (appendix).

For the replication cohort, a total of 19 genes encoding known subunits of GABA_A receptors were selected for deep sequencing (appendix). After quality trimming, sequencing reads were mapped against the GRCh37 human reference genome using the GATK¹⁶ suite and the MUGQIC pipelines (https://bitbucket.org/mugqic/mugqic_pipelines). Data from the control cohort C were processed using the same pipelines as the cases. Coverage comparisons were made to keep bases covered in at least 95% of the subjects as well as the control cohort.

RefSeq gene annotation information was used for the classification into missense and synonymous variants and to filter for rare (allele frequency smaller than 0.5%) variants using the ExAC database¹⁷ (appendix).

Population stratification

For both WES datasets, selected common variants from each study were chosen and principal-components analysis (PCA) was applied to assess potential population substructure separately for each case-control cohort, using the implementation in Eigenstrat¹⁸. Population outliers were defined as SD of >3 based on the first 10 PC and excluded from further analysis (appendix).

Statistical analysis

Due to the limited sample size, single-gene collapsing analysis for the discovery stage was performed using Combined and Multivariate Collapsing¹⁹(CMC) method with a two-sided Fisher's exact test, as implemented in the Exact CMC method in rvtests²⁰ (appendix). P-values for single-gene collapsing tests were corrected for multiple testing by use of the Bonferroni method for 18,668 protein-coding genes.

For all three stages, gene-set collapsing tests were performed using the regression-based two-sided SKAT-O method²¹, as implemented in rvtests²⁰. For the two WES cohorts, we included sex and the first 10 PC from the Eigenstrat analysis as covariates to account for possible gender and population substructure effects. Gene-set collapsing tests were applied separately to missense and to synonymous variants. Three disease-related and four process-specific gene-sets related to GGE were constructed (appendix table S5). To control the family-wise error rate, we applied Holm's correction for multiple testing 14 hypotheses (seven gene-sets for missense and synonymous variants each), in the discovery cohort, while correction was done for only two hypotheses in both the validation and the replication cohort, since only the GABA_A receptor gene-set was carried forward (appendix). The odds ratio (OR) for a given gene-set was determined by comparing the presence of qualifying rare (nonsynonymous or synonymous) variants in all genes within each gene-set between cases and controls using the R package 'fmsb'.

Functional analysis

Functional experiments were performed using automated two-microelectrode voltage clamping in *Xenopus* oocytes. All methods for functional studies have been described previously^{21,22} (appendix).

Role of the funding source

The funders of the study had no role in study design, data collection, data analysis, data interpretation or writing. The authors had full access to the data in the study and had final responsibility for the decision to submit for publication.

Results

We first performed WES in a discovery cohort of 238 independent, mainly familial cases of classical forms of GGE (CAE/JAE, JME or EGTCa). As controls, we used the ethnically matched (figure S1) population control cohort A from the Rotterdam study¹³, that used the same enrichment and sequencing procedures, albeit with a somewhat lower coverage. After quality control (QC) and population outlier removal, the final dataset consisted of 152 unrelated GGE and 549 control samples. To adjust for the different coverage, we considered only variants with an average read depth of >10 both in case and control samples (figure S2). From 701 samples, 204,023 exonic and splice site variants were called. The mean exonic transition/transversion ratio equaled 3.46, indicating good data quality. Rare variants (MAF<0.005) were classified as missense (Nonsyn) and silent (Syn) variants. 93,893 Nonsyn and 55,170 Syn variants constituted the analysis data set (see appendix, table S4). When testing hypothesis-free all RefSeq genes separately for association, we could not identify genes enriched for any variant type (appendix). Therefore, we next applied an independent hypothesis-driven analysis by testing the enrichment of rare variants in seven gene-sets related to epilepsy or underlying molecular processes, representing (i) all voltage-gated cation channels, (ii) all excitatory postsynaptic receptors, (iii) all GABA_A receptors as the main inhibitory postsynaptic receptors, (iv) more broadly the GABAergic pathway (since such genes have been associated specifically with generalized epilepsies), and genes associated (v) with generalized epilepsies, (vi) epileptic encephalopathies, or (vii) focal epilepsies (appendix table S4). We tested separately for each variant type; silent variants were expected to show no difference between cases and controls. We found an enrichment for missense variants in the GABA_A receptor gene-set which was significant when correcting for multiple comparisons in the seven gene-sets for both Nonsyn and Syn (so 14 altogether) by use of the two-sided SKAT-O test (19 genes, $p_{\text{Nonsyn}}=0.0014$, adjusted $p^*_{\text{Nonsyn}}=0.019$, OR=2.40, 95% CI=[1.41,4.10]) (table 1). However, the GABA_A receptor gene-set would not have reached study-wide significance when also correcting for all single genes tested before. None of the other gene-sets showed a significantly increased burden of rare variants. Synonymous variants, used as a negative control, did not show a significant enrichment in any of the gene-sets (tables 1 and S8).

To validate the finding for the GABA_A receptor encoding genes, we used the second, validation cohort, consisting of 724 individuals with GGE from six European countries. They were mainly sporadic (n=268, 37%) or of unknown familial history (n=265, 37%) and diagnosed with classical forms of GGE (table S2). For comparison, control cohort B from the Rotterdam study¹⁴ was used. After applying the same QC steps as for the discovery stage, the dataset consisted of 357 unrelated GGE and 1485 control samples. Consistent with the discovery stage, we observed a significant enrichment of rare missense variants in the GABA_A receptor gene-set in cases after multiple-testing correction for two sets of variants (Nonsyn, Syn; $p_{\text{Nonsyn}}=0.0081$, adjusted $p^*_{\text{Nonsyn}}=0.016$, OR=1.46, 95% CI=[1.05,2.03]) using the SKAT-O test (table 1 and S8). Synonymous variants showed no significant enrichment.

For a third, independent replication cohort, consisting of 631 cases with familial or sporadic GGE (table S3), we designed a targeted enrichment panel comprising all 19 GABA_A receptor encoding genes. *GABRR3* was excluded for QC reasons. Since no genotype data for the cases were available and therefore gender QC could not be performed, the burden analysis was restricted to the remaining 15 autosomal GABA_A receptor genes. We obtained control samples from the UK10K project (<https://www.uk10k.org/>) and selected 639 individuals after sample QC. Additional variant QC led to a final dataset of 583 unrelated cases and 635 controls. We replicated a significant enrichment of rare missense variants for 15 GABA_A receptor genes in cases compared to controls ($p_{\text{Nonsyn}}=0.013$, adjusted $p^*_{\text{Nonsyn}}=0.027$, OR=1.46, 95% CI=[1.02,2.08], table 1) by use of a SKAT-O test. Synonymous variants were not significantly enriched.

We thus conclude that enrichment of rare missense variants in GABA_A receptor encoding genes is reproducibly present in individuals with GGE compared to controls. All detected case-only variants are provided in tables S8 and S9. Case-only rare missense variants were found across all GABA_A receptor genes except in *GABRR3* (table S8).

The combination of two α_1 -, two β_2 - and one γ_2 -subunit (genes *GABRA1*, *GABRB2*, *GABRG2*) represents the most common form of a functional GABA_A receptor in the brain²⁴, and variants in *GABRA1* and *GABRG2* have been shown to play an important role in familial GGE, febrile seizures and EE^{4,5,22,23,25-27}. Importantly, the observed enrichment of missense variants was not driven by variants in those two epilepsy genes; the signal was no longer significant when reducing the analysis to those two genes (table S9). Instead, the qualifying variants were evenly distributed over all GABA_A receptor encoding genes. The α_5 subunit (gene *GABRA5*) is supposed to mediate extrasynaptic tonic inhibition²⁸, and tonic inhibition has been described to be altered in genetic mouse models of epilepsy^{29,30}. *GABRB2* and *GABRA5* have not previously been associated with GGE, although *GABRB2* mutations were described recently in patients with intellectual disability and epilepsy³¹⁻³³.

For functional studies, we therefore selected seven missense variants in *GABRB2* and *GABRA5* (appendix, point 6 and table S10) identified in GGE families for electrophysiological studies in *Xenopus* oocytes. All selected variants were confirmed by Sanger sequencing. Five of these variants were selected since they co-segregated with the phenotype in nuclear families. Another variant (p.R3S) was found in three different French-Canadian pedigrees, so we hypothesized that this could be a more common causal variant in a specific population (figures 1a and 2a). The last variant, p.P453L, did not co-segregate, but was selected as additional *GABRA5* variant localized in a different protein region (the C-terminus) than the other variants. All missense variants were predicted to be deleterious by at least three out of seven prediction tools and were highly conserved (table S9). Three of these variants were consistently of ultra-low frequency in the European population in different public databases (1000G, ExAC, gnomAD; table S9). Localization of the variants is shown in figures 1b and 2b.

After application of 1 mM GABA, we observed a significant reduction in current amplitudes of GABA_A receptors containing either p.K221R or p.V316I variants in the β_2 -subunit, and p.M1I or p.S238N in the α_5 -subunit, in comparison to respective compositions of WT receptors. No significant reductions were observed for p.R3S in the β_2 - and for p.E243K or p.P453L in the α_5 -subunit (figures 1c, 1d, 2c, 2d). The GABA sensitivity was similar for WT and all of the variant-carrying receptors (figures 1e, 2e). Thus, four out of seven variants lead to a loss of receptor function predicting postsynaptic or extrasynaptic neuronal disinhibition.

All four variants inducing significantly reduced current amplitudes co-segregated with the disease phenotype in respective pedigrees (figures 1a, 2a), corroborating their pathophysiological contribution. In two families, we observed co-segregating variants in two different GABA_A receptor subunits: p.V316I in the β_2 - and p.M1I in the α_5 -subunit co-occurred in the same nuclear family, and p.E243K in the α_5 -subunit was accompanied by a deleterious frameshift mutation in *GABRG2* in another family (figures 1a, 2a). We did not see a significant change in GABA-evoked currents for p.E243K, suggesting that *GABRG2* may be a dominant disease-contributing gene in this family. However, as GGE only occurs in individuals carrying variants in both genes, we cannot exclude that p.E243K contributes to the phenotype with a more subtle functional change that could not be detected in our assay. Variants with altered receptor function were all located in the N-terminus containing GABA-binding sites or in the pore region. p.M1I suppresses the start codon such that translation starts six amino acids later, which shortens the signalling peptide consisting of the first 20 amino acids. While the peptide is removed and not part of the mature GABA_A receptor in the plasma membrane, this alteration could still affect protein biogenesis leading to reduced expression of functional receptors. p.R3S, which also affects the signalling peptide, and p.P453L, located in the functionally less relevant C-terminus, did not lead to a significant change in receptor function. p.R3S recurred in three French-Canadian families and p.P453L was detected

in only one of several affected members of a larger family indicating that they might represent benign polymorphisms.

Discussion

We report an enrichment of rare missense variants in GABA_A receptor subunit encoding genes in three independent cohorts which together comprise >1000 GGE index cases (both familial and sporadic). Four selected variants in two genes (*GABRB2*, *GABRA5*) previously not associated with GGE changed receptor function and co-segregated in nuclear families, suggesting an important contribution to the GGE phenotype. Previous studies in smaller cohorts failed to show a significant excess of variants in cases versus controls either investigating all ion channel encoding genes⁸ or using single-gene collapsing tests based on whole exomes⁹. The difference between these previous studies and ours could be explained by (i) a larger sample size in our study across all cohorts and (ii) by testing different gene-sets that had not been considered before. In a recent study¹⁰, a similar effect could be shown for ultra-rare deleterious variants in gene-sets comprising known epilepsy genes or genes associated with epileptic encephalopathies (GABA_A receptor genes were not investigated as a separate gene-set). Due to our smaller sample size and the associated low number of ultra-rare variants, we here chose a different approach considering all variants with a MAF<0.5%, which revealed significant genetic signals in studies of other diseases³⁴⁻³⁶. Both studies (i.e. Epi4k and ours) failed to identify single genes with a genome-wide significant burden of rare variants in individuals with GGE. It will be interesting in future studies to combine different cohorts to increase power for such analyses and shed further light on the complex genetic architecture of GGE.

One limitation of our study is that the cohorts, due to funding restrictions of the individual projects, were sequenced at different locations using different technologies. Combining and analysing such data in an unbiased way is still a major challenge. To minimize any bias, we used only those regions after QC that were available for all samples. An a priori selection bias for the targeted genes yielding a false significance can also not be completely ruled out. The careful choice of gene-sets was based on biological and published evidence and did not change the selection afterwards which should minimize selection bias and associated false-positive findings. Furthermore, we used a stringent QC and consistent processing of all datasets, and altogether three independent case and control datasets for discovery, validation and replication of results. Neutral signals emerging from the synonymous variants across all case-control studies suggest that we controlled for any major population structure or other confounding factor.

One of the variants we functionally examined in our study (p.V316I in *GABRB2*) has been identified in the meantime as a *de novo* mutation in a cohort of severe developmental and epileptic encephalopathies using whole genome sequencing of parent-patient trios³². This finding corroborates the pathogenicity of this variant. Association of genetic variants with different

phenotypes is well-known as pleiotropy and has also been described in other GABA_A receptor encoding genes^{3,24} including large phenotypic variability within one extended pedigree³.

We have also recently characterized the variant p.T336M in *GABRA3* – which was detected in our discovery cohort (table S8) – as part of another study in which we identified *GABRA3* as a new epilepsy gene associated with highly heterogeneous epileptic phenotypes including asymptomatic variant carriers³⁷. This variant also causes a severe loss-of-function effect but does not co-segregate in the respective pedigree, so that other factors must contribute to the GGE at least in two family members. While co-segregation is a strong indicator for the pathogenicity of genetic variants, we have to be aware that GGE is a common disease with complex inheritance. Variants in GABA_A receptor encoding genes could therefore still contribute to the disease, whereas other family members not carrying the respective variants must have other causes of their epilepsy. Similarly, copy number variations often do not co-segregate within nuclear families but have been replicated as a significant risk factor for GGE^{38–41}. Given the reproducibility of our results, co-segregation and functional evidence, many but not all of the detected variants may contribute to the etiology of GGE in our three cohorts. This disease-relevant contribution may range from a major gene effect – as observed in ‘monogenic’ Mendelian epilepsies – to relatively small effect sizes in the variant carriers, depending on the amount of the electrophysiological dysfunction and other unknown factors, such as the genetic background. Overall, we consider the enrichment of GABA_A receptor variants in cases vs. controls as a significant risk factor to develop GGE.

Lastly, our results indicate a genetic overlap among rare and common forms of epilepsy, since there is increasing evidence that *de novo* variants in GABA_A receptor encoding genes cause severe forms of epileptic encephalopathies^{22–26,37,42} and they re-iterate a central role of GABAergic mechanisms in generalized epilepsies^{3–5,23–25,27–31,43,44}.

Contributions

HL, RolK, PC, FZ, SM, PN, PM and SG designed the study. FB, SW, PLT, CM MG, SB, PS, HC, AS, KE, RB, RolK, RSM, HH, HM, IH, WK, YGW, SW, PdJ, SMS, SS, RN, SF, AC, MSV, DKNT, BB, UO, NB, KMK, FR, DKN, FD, LC, AL, RD, JFC, CCW, GA, TS, ELG, BPCCK, FZ, PC, HL, GJS, PA, BF, MRJ, AGM, BBe, JWS, AA, MMc, GLC, ND, CD, MK, FZi, MNi, and the Epicure, EuroEPINOMICS CoGIE and the EpiPGX consortia recruited and phenotyped subjects. JvR, RK, AI, AGU recruited, phenotyped and analysed the Rotterdam cohort individuals. PM, SG, DRB, SaP, JS, CDK, MT, AP, MI, RGL, SB, CM, HT, JA, KJ, AKR, WJ, DL, ELG, JMS, BPCCK, AP, AEL, MN, PN, FZ, PC, RolK, and HL performed or supervised genetic studies (Sanger or whole exome sequencing, or data analysis), MH, CEN, JK, RR, SC, BT, IDC, CAR, SS, SP, MM, SM and HL performed or supervised functional studies, PM, SG, MH, DRB, JS, SW,

and HL wrote the manuscript. Consortia members collected data. All authors revised the manuscript.

Declarations of interests

HL reports grants from Deutsche Forschungsgemeinschaft (DFG), grants from European Commission, other from Foundation no-epilep, grants from Deutsche Gesellschaft für Epileptologie (DGfE), during the conduct of the study; personal fees for consulting, speaking or travel support from Bial, Biomarin, Desitin, Eisai, and UCB Pharma, outside the submitted work; he received funding from DFG, BMBF, EU DGfE and the foundation noepilep related in part to this work. KMK reports personal fees from UCB Pharma, Novartis Pharma AG, and Eisai, outside the submitted work. SP reports other from Praxis Precision Medicine, grants from RogCon, other from Pairnomix, outside the submitted work; In addition, SP has a patent U.S. Provisional Application 62/450,025 pending. FR reports personal fees and non-financial support from UCB Pharma, personal fees from Shire, personal fees from EISAI, personal fees from Desitin Arzneimittel, personal fees from Bial, personal fees from cerbomed, GW-Pharma, Bayer Vital, Sandoz, University of Munich (LMU), and from Verband der forschenden Arzneimittelindustrie, non-financial support from Novartis Japan, grants from European Union, FP7, grants from Hessisches Ministerium für Wissenschaft und Kunst (LOEWE-Programme), personal fees from University of Munich (LMU), grants from Detlev-Wrobel Fonds for Epilepsy Research, outside the submitted work. AA is employed by UCB Pharma SPRL, Belgium, as Associate Director; he reports grants from the European Commission, during the conduct of the study; other from UCB Pharma, Belgium, outside the submitted work. AGM was awarded grants from GSK, Eisai and UCB Pharma, which funded the National Audit of Seizure Management in Hospitals, and the European Union during the conduct of the study. JWS reports grants and personal fees from Eisai, grants and personal fees from UCB, grants from WHO, grants from NEF, personal fees from Eisai, grants and personal fees from UCB, outside the submitted work; and Prof Sander's current position is endowed by the Epilepsy Society, he is a member of the Editorial Board of the Lancet Neurology, and receives research support from the Marvin Weil Epilepsy Research Fund. AC was awarded a grant from EISAI and personal fees for speaking from Eisai, outside of the submitted work. GJS reports grants from the European Commission (FP7), during the conduct of the study; personal fees from UCB Pharma, personal fees from Eisai Ltd., outside the submitted work. CD reports grants and personal fees from UCB Pharma, outside the submitted work. AP reports grants and personal fees from serving the Pfizer Genetics Scientific Advisory Panel and the FinnGen Project, outside the submitted work. RB reports other from Co-Founder of "Theracule", other from Co-Founder of "Megeno", outside the submitted work. PA reports grants from the EU FP7 (EpiPGX), during the conduct of the study. PM is Co-Founder of "Megeno", outside the submitted work. The other authors declare no competing financial interests.

Acknowledgements

We thank all individuals who participated in this study. The study was supported by the European Commission (FP6 project Epicure, LSHM-CT-2006-037315 to HL, FZ, PN, AEL, BPCCK, JMS, ELG, CM, TS, MM, SS, GA, FR, SF, RN, WK, and FP7 Grant 279062 EpiPGX to SMS, HL, GLC, GJS, MRJ, AGM, CD, FZ, WK, JWS, BPCCK), by the European Science Foundation (EuroEPINOMICS project, grants from national funding agencies: DFG: Le1030/11-1/2 to HL, Nu50/8-1 to PN, Sa434/5-1 to TS, He5415/3-1 to IH; FNR: INTER/ESF/10/02/CoGIE to RB; Academy of Finland 141549 to AEL; TUBITAK 110S518 to HC.; associated partners without funding were: FZ, AP, BPCCK, MM, SP, SS), by Research Unit FOR2715 of the DFG and the FNR (grants Le1030/16-1, Nu50/11-1, Kr5093/2-1), by the German Society for Epileptology (DGfE: to HL, YGW, IH and HM), by the foundation no-epilep (to HL), the Epilepsy Society UK (to JWS, SMS), Wellcome Trust (086185/Z/08/Z to IDC), the MRC (MR/J002976/1 to IDC), the Royal Society (to SS), and the International Coordination Action (ICA) grant G0E8614N (to SW), by the JPND Courage-PD research grant (PM, DRB) and the FNR NCER-PD grant (RB, PM). The work was partly undertaken at UCLH/UCL, which received a proportion of funding from the UK Department of Health's NIHR Biomedical Research Centres funding scheme. MMc and GLC are supported by Science Foundation Ireland, grant 13/CDA/2223. MMc is supported by a Marie-Curie Individual Fellowship (No. 751761) from the European Commission. This work was partly performed at UCLH/UCL, which received a proportion of funding from the Department of Health's NIHR Biomedical Research Centres funding scheme (JWS, SMS). The generation and management of genomics data for the Rotterdam Study are supported by the Netherlands Organisation of Scientific Research NOW Investments (nr. 175.010.2005.011, 911-03-012) and the Netherlands Genomics Initiative (NGI)/NOW project nr. 050-060-810 (Netherlands Consortium for Healthy Ageing; NCHA). We thank the members of the Genomics Lab and the ERGO support team for their help in sampling the data and in creating the database. The Rotterdam Study is funded by Erasmus Medical Center and Erasmus University, Rotterdam, Netherlands Organization for the Health Research and Development (ZonMw), the Research Institute for Diseases in the Elderly (RIDE), the Ministry of Education, Culture and Science, the Ministry for Health, Welfare and Sports, the European Commission (DG XII), and the Municipality of Rotterdam. The authors are grateful to the study participants, the staff of the Rotterdam Study and the participating general practitioners and pharmacists. Parts of the computational analysis was performed on the high-performance computer system of the University of Luxembourg (<https://hpc.uni.lu>).

Epicure Consortium

Merle Harrer, Julian Schubert, Carolien De Kovel, Mohamad Toliat, Anne Polvi, Michele Iacomino, Rosa Guerrero-López, Stéphanie Baulac, Carla Marini, Raffaella Rusconi, Benedetta

Terragni, Pasquale Striano, Auli Siren, Hiltrud Muhle, Ingo Helbig, Wolfram Kunz, Yvonne G. Weber, Rima Nabbout, Edoardo Ferlazzo, Carlo di Bonaventura, Angela La Neve, Paolo Tinuper, Francesca Bisulli, Aglaia Vignoli, Giuseppe Capovilla, Giovanni Cricchiutti, Antonio Gambardella, Vincenzo Belcastro, Amedeo Bianchi, Silvana Franceschetti, Antonietta Coppola, Maria S. Vari, Dorothee Kasteleijn-Nolst Trenité, Betul Baykan, Ugur Ozbek, Nerses Bebek, Karl-Martin Klein, Felix Rosenow, Giuliano Avanzini, Stephanie Schorge, Massimo Mantegazza, Thomas Sander, Eric LeGuern, Jose M. Serratos, Bobby P.C. Koeleman, Anna-Elina Lehesjoki, Peter Nürnberg, Snezana Maljevic, Federico Zara and Holger Lerche.

EuroEPINOMICS CoGIE Consortium

Patrick May, Merle Harrer, Julian Schubert, Felicitas Becker, Stefan Wolking, Cristina Elena Niturad, Julia Knaus, Stéphanie Baulac, Holger Thiele, Janine Altmüller, Kamel Jabbari, Ann-Kathrin Ruppert, Wiktor Jurkowski, Dennis Lal, Pasquale Striano, Hande Caglayan, Destina Yalçın, Gulsen Dizdärer, Kezban Arslan, Zuhul Yapici, Demet Kuşcu, Auli Siren, Kate Everett, Rikke S. Møller, Helle Hjalgrim, Marina Nikanorova, Hiltrud Muhle, Ingo Helbig, Wolfram Kunz, Yvonne Weber, Sarah Weckhuysen, Peter De Jonghe, Sanjay Sisodiya, Rima Nabbout, Rudi Balling, Stephanie Schorge, Steven Petrou, Massimo Mantegazza, Thomas Sander, Eric LeGuern, Jose M. Serratos, Bobby P.C. Koeleman, Aarno Palotie, Anna-Elina Lehesjoki, Michael Nothnagel, Peter Nürnberg, Snezana Maljevic, Federico Zara, Roland Krause and Holger Lerche.

EpiPGX Consortium

Rikke S. Møller, Marina Nikanorova, Chantal Depondt, Michael M. Johnson, Sarah R. Langley, Karl M. Klein, Mark McCormack, Norman Delanty, Gianpiero L. Cavalleri, Hiltrud Muhle, Mojgansadat Borghei, Joseph Willis, Costin Leu, Kristin Heggeli, Andreja Avbersek, Sanjay M. Sisodiya, Josemir W. Sander, Antonio Gambardella, Sarah Weckhuysen, Bianca Berghuis, Wolfram S. Kunz, Pasquale Striano, Federico Zara, Anthony G. Marson, Andrea Jorgensen, Pauls Auce, Ben Francis, Prashant Srivastava, Graeme J. Sills, Sarah Peter, Roland Krause, Stefan Wolking, Yvonne G. Weber, Sarah Rau, Christian Hengsbach, Holger Lerche, Anja C.M. Sonsma, Martin Krenn, Fritz Zimprich.

References

- 1 Scheffer IE, Berkovic S, Capovilla G, *et al.* ILAE classification of the epilepsies: Position paper of the ILAE Commission for Classification and Terminology. *Epilepsia* 2017; **58**: 512–21.
- 2 Berkovic SF, Howell RA, Hay DA, Hopper JL. Epilepsies in twins: Genetics of the major epilepsy syndromes. *Ann Neurol* 1998; **43**: 435–45.
- 3 Wallace RH, Marini C, Petrou S, *et al.* Mutant GABAA receptor γ 2-subunit in childhood

absence epilepsy and febrile seizures. *Nat Genet* 2001; **28**: 49–52.

4 Baulac S, Huberfeld G, Gourfinkel-An I, *et al.* First genetic evidence of GABA(A) receptor dysfunction in epilepsy: a mutation in the gamma2-subunit gene. *Nat Genet* 2001; **28**: 46–8.

5 Cossette P, Liu L, Brisebois K, *et al.* Mutation of GABRA1 in an autosomal dominant form of juvenile myoclonic epilepsy. *Nat Genet* 2002; **31**: 184–9.

6 Arsov T, Mullen SA, Rogers S, *et al.* Glucose transporter 1 deficiency in the idiopathic generalized epilepsies. *Ann Neurol* 2012; **72**: 807–15.

7 Striano P, Weber YG, Toliat MR, *et al.* GLUT1 mutations are a rare cause of familial idiopathic generalized epilepsy. *Neurology* 2012; **78**: 557–62.

8 Klassen T, Davis C, Goldman A, *et al.* Exome sequencing of ion channel genes reveals complex profiles confounding personal risk assessment in epilepsy. *Cell* 2011; **145**: 1036–48.

9 Heinzen EL, Depondt C, Cavalleri GL, *et al.* Exome sequencing followed by large-scale genotyping fails to identify single rare variants of large effect in idiopathic generalized epilepsy. *Am J Hum Genet* 2012; **91**: 293–302.

10 Epi4K Consortium, Epilepsy Phenome/Genome Project. Ultra-rare genetic variation in common epilepsies: a case-control sequencing study. *Lancet Neurol* 2017; **16**: 135–43.

11 Agostinelli S, Accorsi P, Beccaria F, *et al.* Clinical dissection of early onset absence epilepsy in children and prognostic implications. *Epilepsia* 2013; **54**: 1761–70.

12 Galizia EC, Myers CT, Leu C, *et al.* CHD2 variants are a risk factor for photosensitivity in epilepsy. *Brain* 2015; **138**: 1198–208.

13 Hofman A, Brusselle GGO, Darwish Murad S, *et al.* The Rotterdam Study: 2016 objectives and design update. *Eur J Epidemiol* 2015; **30**: 661–708.

14 Ikram MA, Brusselle GGO, Murad SD, *et al.* The Rotterdam Study: 2018 update on objectives, design and main results. *Eur J Epidemiol* 2017; **32**: 807–50.

15 UK10K Consortium, Walter K, Min JL, *et al.* The UK10K project identifies rare variants in health and disease. *Nature* 2015; **526**: 82–90.

16 DePristo MA, Banks E, Poplin R, *et al.* A framework for variation discovery and genotyping using next-generation DNA sequencing data. *Nat Genet* 2011; **43**: 491–8.

17 Lek M, Karczewski KJ, Minikel EV, *et al.* Analysis of protein-coding genetic variation in 60,706 humans. *Nature* 2016; **536**: 285–91.

18 Price AL, Patterson NJ, Plenge RM, Weinblatt ME, Shadick NA, Reich D. Principal components analysis corrects for stratification in genome-wide association studies. *Nat Genet* 2006; **38**: 904–9.

19 Li B, Leal SM. Methods for Detecting Associations with Rare Variants for Common Diseases: Application to Analysis of Sequence Data. *Am J Hum Genet* 2008; **83**: 311–21.

20 Zhan X, Hu Y, Li B, Abecasis GR, Liu DJ. RVTESTS: an efficient and comprehensive tool for rare variant association analysis using sequence data. *Bioinforma Oxf Engl* 2016; **32**: 1423–6.

21 Lee S, Emond MJ, Bamshad MJ, *et al.* Optimal Unified Approach for Rare-Variant Association Testing with Application to Small-Sample Case-Control Whole-Exome Sequencing Studies. *Am J Hum Genet* 2012; **91**: 224–37.

22 Möhler H. GABAA receptor diversity and pharmacology. *Cell Tissue Res* 2006; **326**: 505–16.

23 Johannesen K, Marini C, Pfeffer S, *et al.* Phenotypic spectrum of GABRA1: From generalized epilepsies to severe epileptic encephalopathies. *Neurology* 2016; **87**: 1140–51.

- 24 Møller RS, Wuttke TV, Helbig I, *et al.* Mutations in *GABRB3*: From febrile seizures to epileptic encephalopathies. *Neurology* 2017; **88**: 483–92.
- 25 Kang J-Q, Macdonald RL. Molecular Pathogenic Basis for *GABRG2* Mutations Associated With a Spectrum of Epilepsy Syndromes, From Generalized Absence Epilepsy to Dravet Syndrome. *JAMA Neurol* 2016; **73**: 1009.
- 26 Epi4K Consortium, Epilepsy Phenome/Genome Project. De novo mutations in epileptic encephalopathies. *Nature* 2013; **501**: 217–21.
- 27 Shen D, Hernandez CC, Shen W, *et al.* De novo *GABRG2* mutations associated with epileptic encephalopathies. *Brain* 2017; **140**: 49–67.
- 28 Caraiscos VB, Elliott EM, You-Ten KE, *et al.* Tonic inhibition in mouse hippocampal CA1 pyramidal neurons is mediated by 5 subunit-containing γ -aminobutyric acid type A receptors. *Proc Natl Acad Sci* 2004; **101**: 3662–7.
- 29 Hedrich UBS, Liautard C, Kirschenbaum D, *et al.* Impaired Action Potential Initiation in GABAergic Interneurons Causes Hyperexcitable Networks in an Epileptic Mouse Model Carrying a Human NaV1.1 Mutation. *J Neurosci* 2014; **34**: 14874–89.
- 30 Zhang N, Wei W, Mody I, Houser CR. Altered Localization of GABAA Receptor Subunits on Dentate Granule Cell Dendrites Influences Tonic and Phasic Inhibition in a Mouse Model of Epilepsy. *J Neurosci* 2007; **27**: 7520–31.
- 31 Srivastava S, Cohen J, Pevsner J, *et al.* A novel variant in *GABRB2* associated with intellectual disability and epilepsy. *Am J Med Genet A* 2014; **164**: 2914–21.
- 32 Hamdan FF, Myers CT, Cossette P, *et al.* High Rate of Recurrent De Novo Mutations in Developmental and Epileptic Encephalopathies. *Am J Hum Genet* 2017; **101**: 664–85.
- 33 Ishii A, Kang J-Q, Schornak CC, *et al.* A de novo missense mutation of *GABRB2* causes early myoclonic encephalopathy. *J Med Genet* 2017; **54**: 202–11.
- 34 Lee S, Abecasis GR, Boehnke M, Lin X. Rare-Variant Association Analysis: Study Designs and Statistical Tests. *Am J Hum Genet* 2014; **95**: 5–23.
- 35 Auer PL, Lettre G. Rare variant association studies: considerations, challenges and opportunities. *Genome Med* 2015; **7**: 16.
- 36 Bobbili DR, Lal D, May P, *et al.* Exome-wide analysis of mutational burden in patients with typical and atypical Rolandic epilepsy. *Eur J Hum Genet EJHG* 2018; **26**: 258–64.
- 37 Niturad CE, Lev D, Kalscheuer VM, *et al.* Rare *GABRA3* variants are associated with epileptic seizures, encephalopathy and dysmorphic features. *Brain J Neurol* 2017; **140**: 2879–94.
- 38 Helbig I, Mefford HC, Sharp AJ, *et al.* 15q13.3 microdeletions increase risk of idiopathic generalized epilepsy. *Nat Genet* 2009; **41**: 160–2.
- 39 Dibbens LM, Mullen S, Helbig I, *et al.* Familial and sporadic 15q13.3 microdeletions in idiopathic generalized epilepsy: precedent for disorders with complex inheritance. *Hum Mol Genet* 2009; **18**: 3626–31.
- 40 de Kovel CGF, Trucks H, Helbig I, *et al.* Recurrent microdeletions at 15q11.2 and 16p13.11 predispose to idiopathic generalized epilepsies. *Brain J Neurol* 2010; **133**: 23–32.
- 41 Mefford HC. CNVs in Epilepsy. *Curr Genet Med Rep* 2014; **2**: 162–7.
- 42 Shen D, Hernandez CC, Shen W, *et al.* De novo *GABRG2* mutations associated with epileptic encephalopathies. *Brain* 2017; **140**: 49–67.
- 43 Lerche H, Shah M, Beck H, Noebels J, Johnston D, Vincent A. Ion channels in genetic and acquired forms of epilepsy: Ion channels in epilepsy. *J Physiol* 2013; **591**: 753–64.
- 44 Macdonald RL, Kang J-Q, Gallagher MJ. Mutations in GABA_A receptor subunits associated with genetic epilepsies: GABA_A receptor subunits associated with genetic epilepsies.

Figure legends

Figure 1: Characterization of *GABRB2* missense variants associated with GGE

GABRB2 mutations associated with GGE. (a) Family pedigrees. (b) Schematic representation of the β_2 subunit of the GABA_AR and predicted positions of the R3S and K221R mutations located in the N-terminal domain and V316I located in the transmembrane domain 3. (c) Examples of GABA-induced currents after 1 mM GABA application for WT, R3S, K221R and V316I mutations. (d) Current responses normalized to 1 mM GABA application for WT (n=30), R3S (n=24), K221R (n=21) and V316I (n = 16); ***p<0.001, ****p<0.0001, Kruskal Wallis test, with Dunn's comparison test. (e) Dose-response curve for $\alpha 1\beta 2\gamma 2s$ WT (n=30), R3S (n=14), K221R (n=10), V316I (n=7) obtained using application of different GABA concentrations and normalization to the maximal GABA response for each cell.

Figure 2: Characterization of *GABRA5* missense variants associated with GGE

GABRA5 mutations associated with GGE. (a) Family pedigrees. (b) Schematic representation of the α_5 subunit of the GABA_AR and predicted positions of the M1I, S238N and E243K mutations located in the N-terminal domain and P453L located in the C-terminal domain. (c) Examples of GABA-induced currents after application of 1 mM GABA for WT, M1I, S238N, E243K and P453L mutations. (d) Normalized current responses to 1 mM GABA application for WT (n=43), M1I (n=10), S238N (n=13), E243K (n=14) and P453L (n=11); ****p<0.0001, Kruskal Wallis test, with Dunn's comparison test. (e) Dose-response curve for $\alpha 1\beta 2\gamma 2s$ WT (n=37), M1I (n=15), S238N (n=11), E243K (n=8) and P453L (n=8) obtained after application of different GABA concentrations and normalization to the maximal GABA response for each cell.

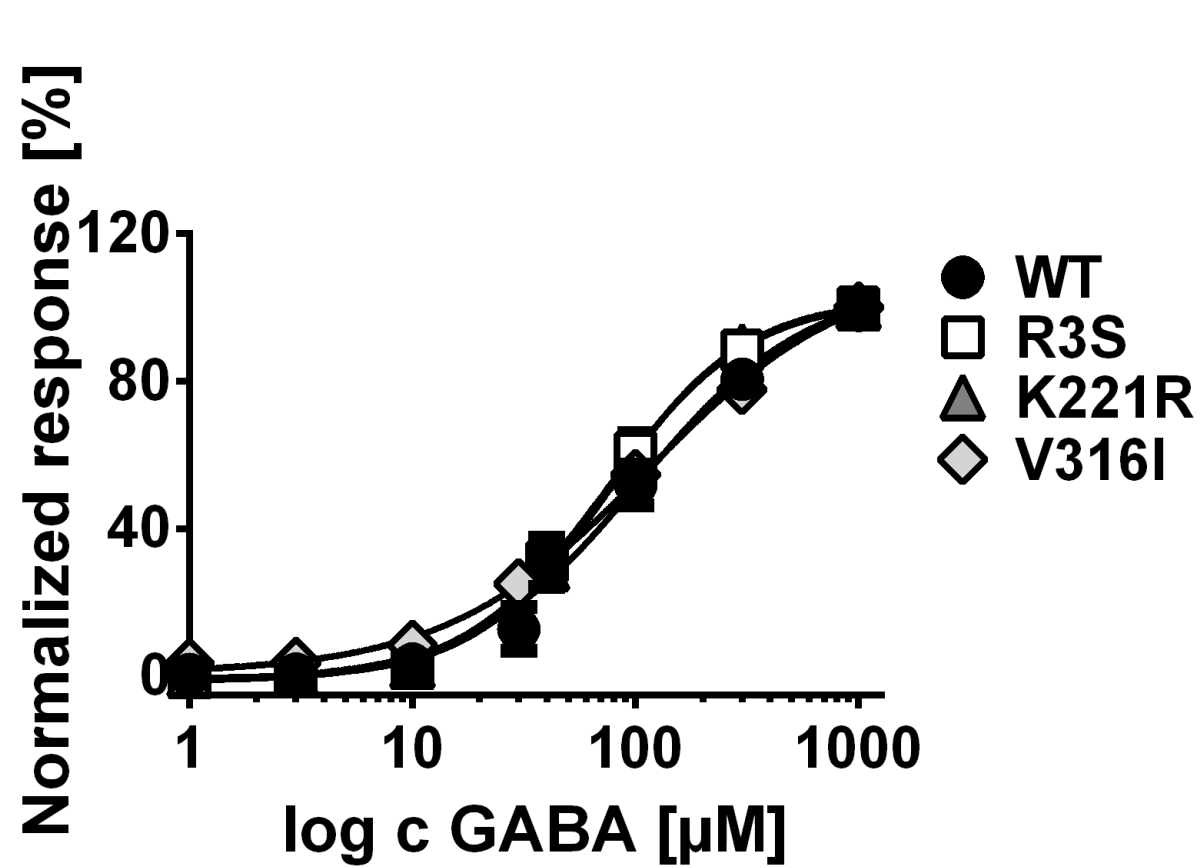
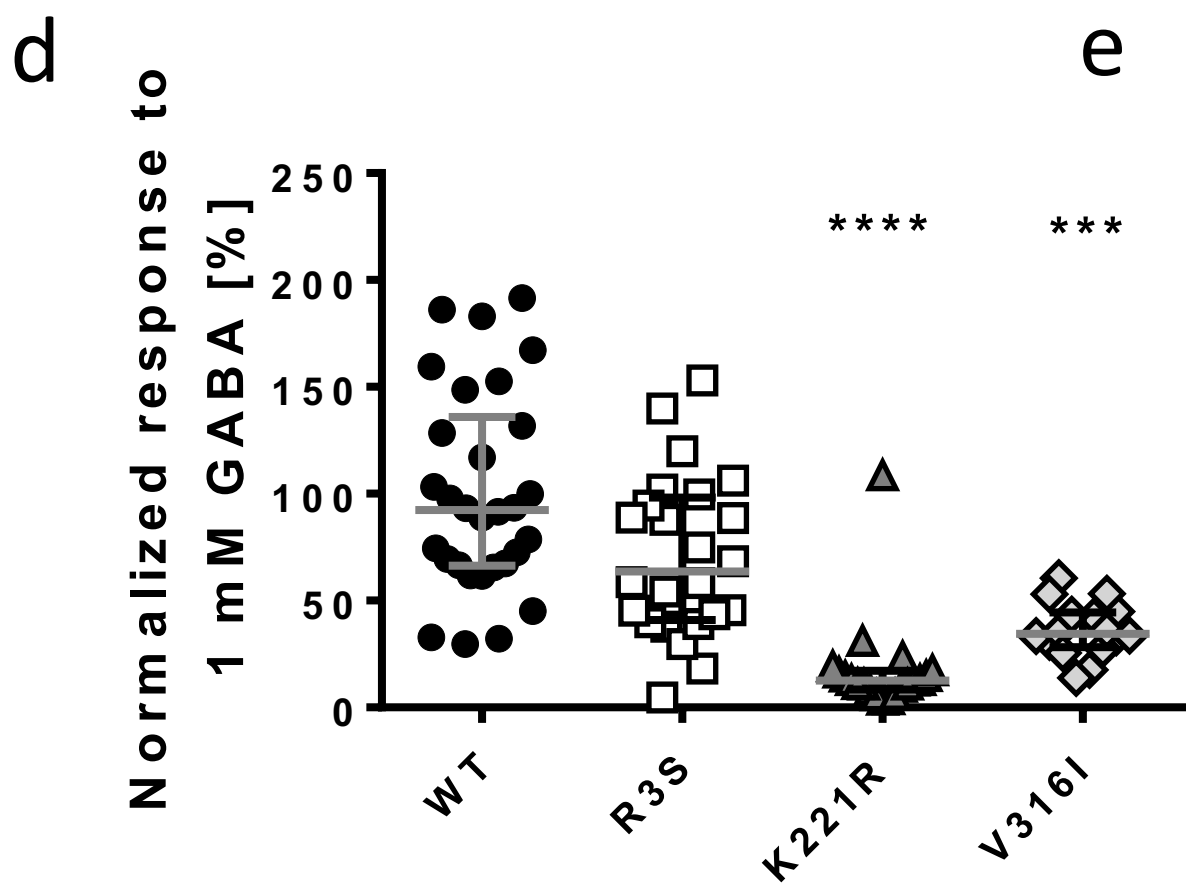
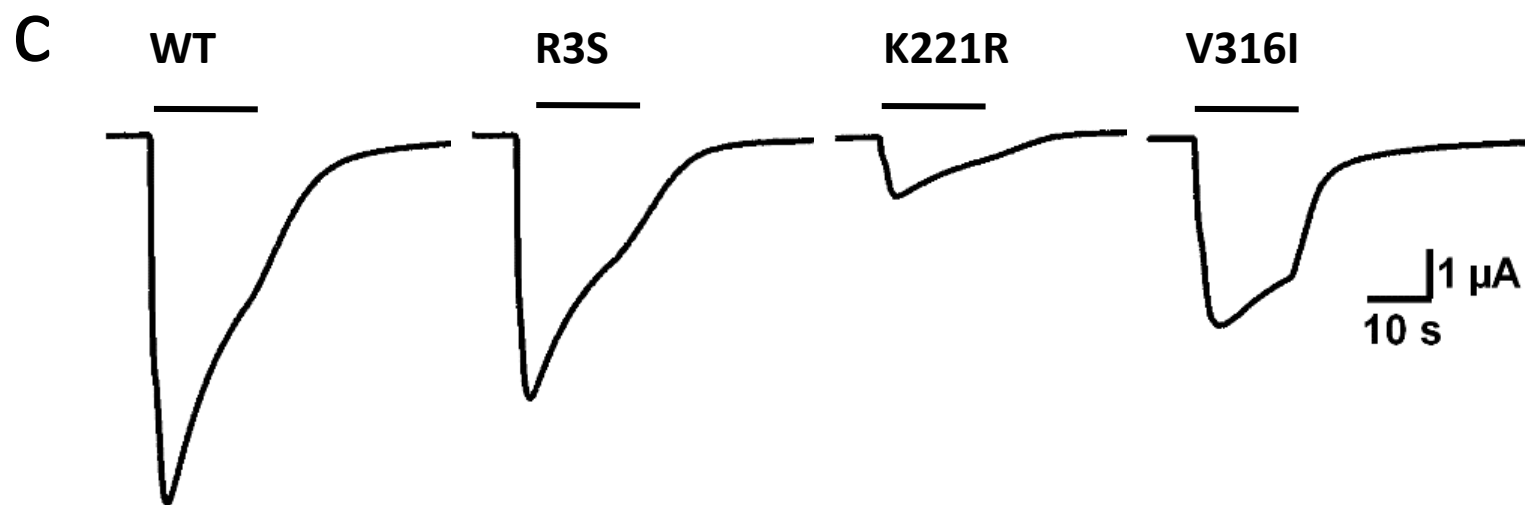
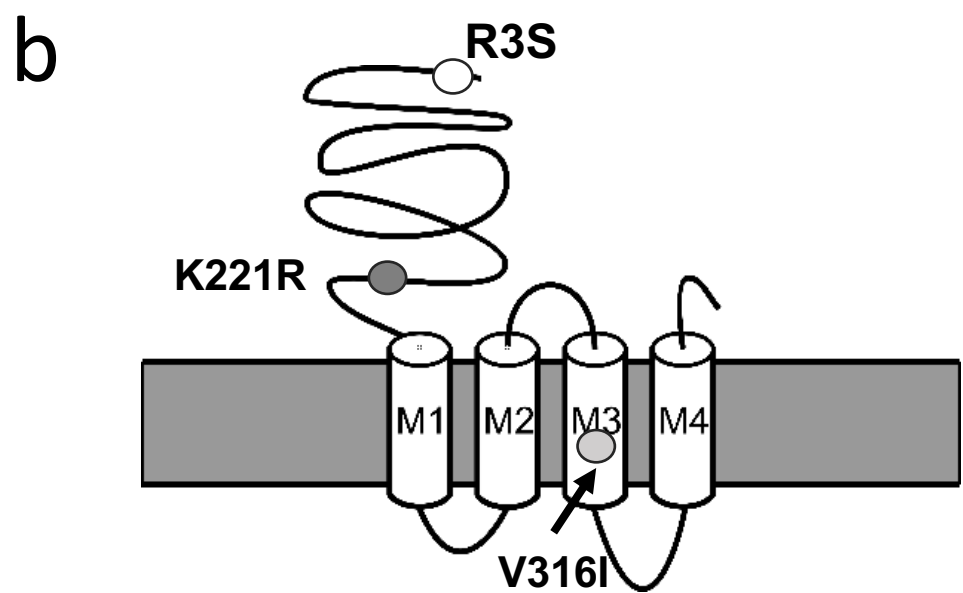
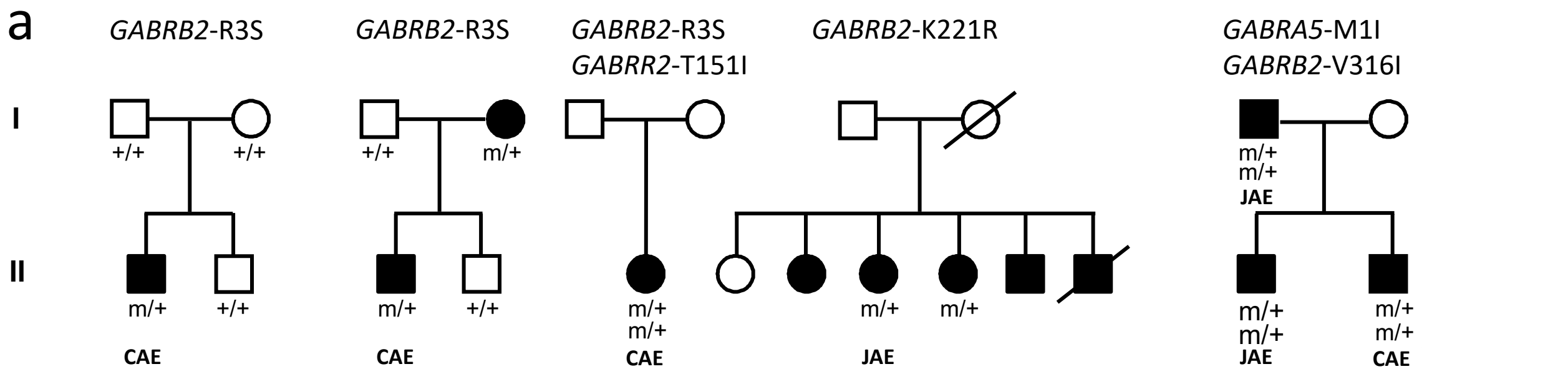

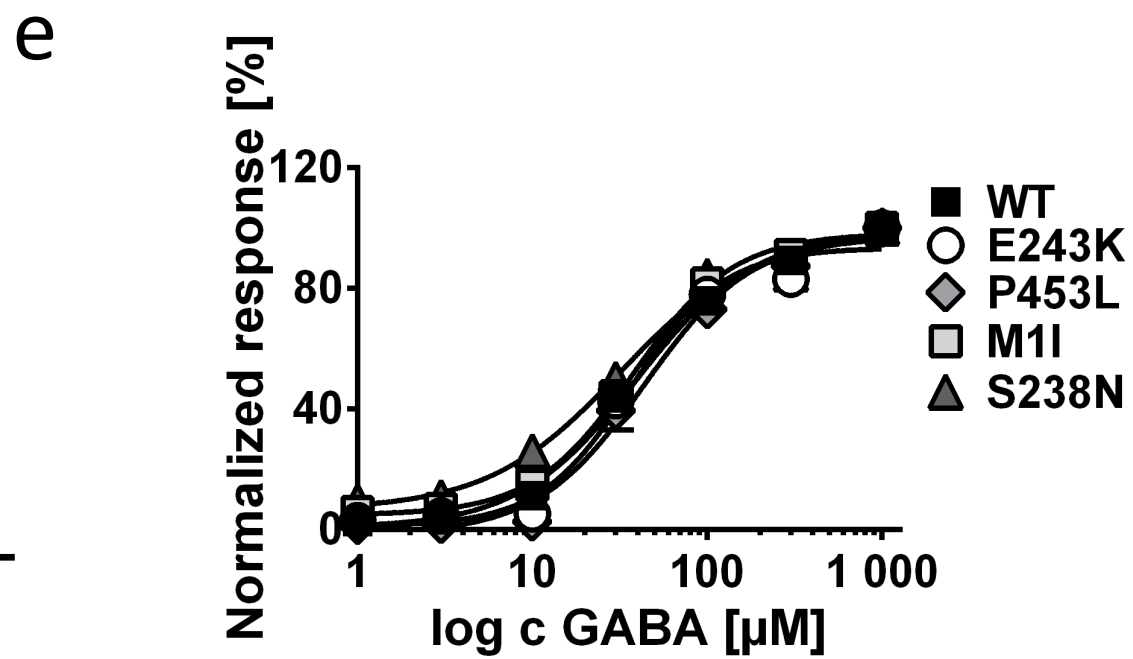
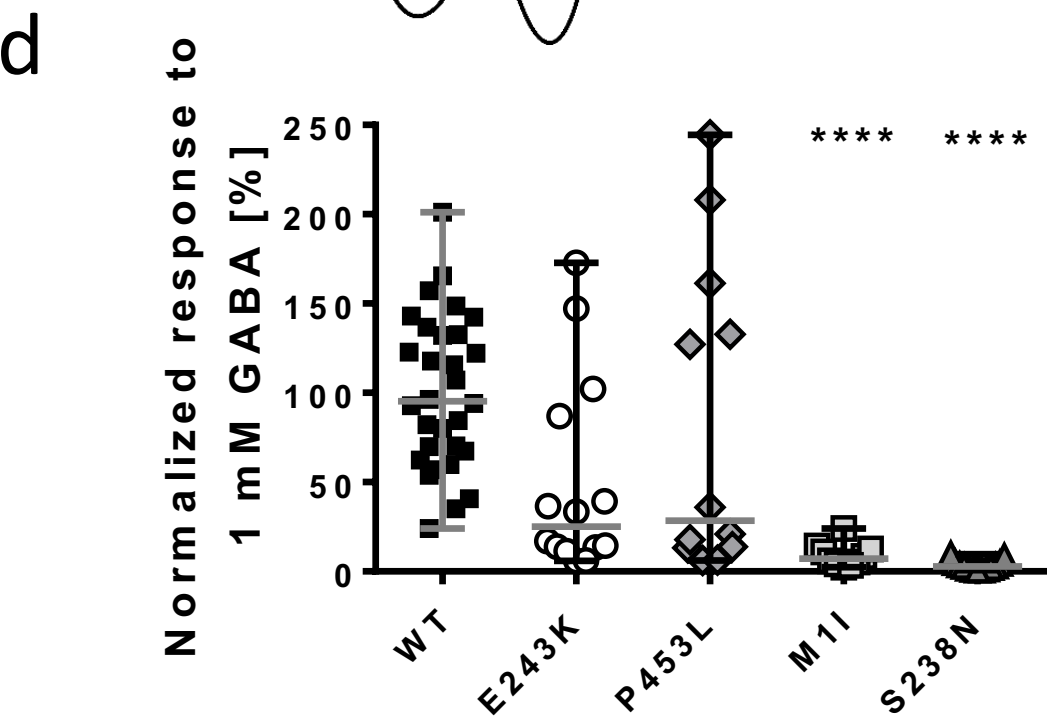
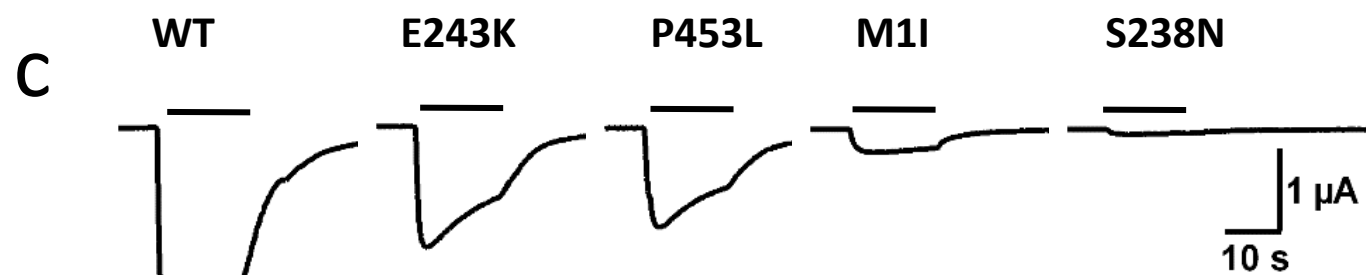
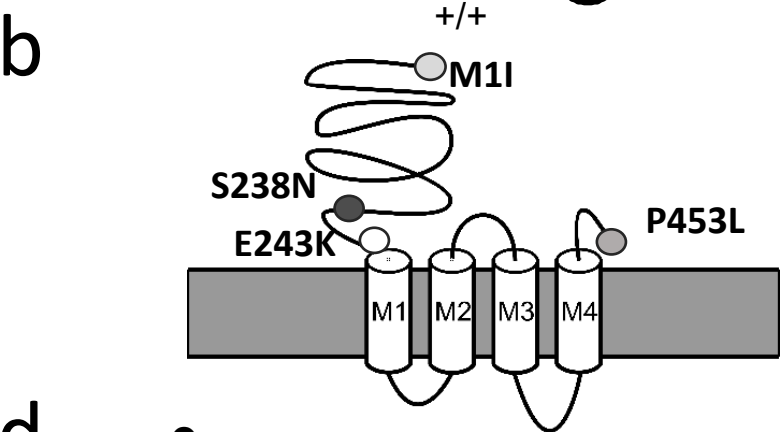
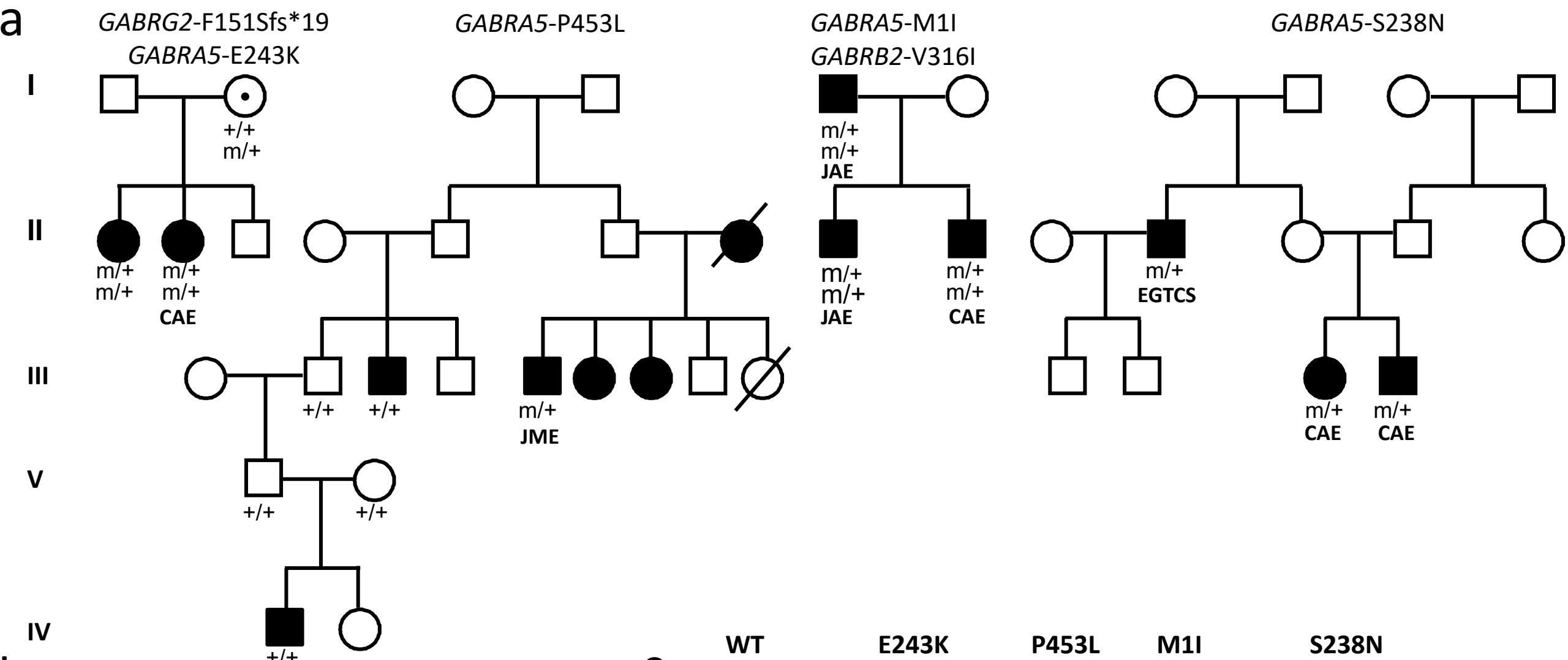

| CoGIE (discovery) | | | | | | | | | |
|----------------------------|---------------|-----------------|--------------|-----------------|----------------------------|--------------------------|-------------|-------------|-------------|
| Gene-set | Variant class | Number variants | Number cases | Number controls | SKAT-O P-value uncorrected | SKAT-O P-value corrected | OR | Lower CI | Upper CI |
| Epileptic encephalopathies | SYN | 284 | 152 | 549 | 0.292299 | 1 | 1.25 | 0.87 | 1.80 |
| Excitatory receptors | SYN | 151 | 152 | 549 | 0.212472 | 1 | 1.43 | 0.97 | 2.11 |
| Focal epilepsies | SYN | 110 | 152 | 549 | 0.416506 | 1 | 1.07 | 0.68 | 1.66 |
| GABAergic pathway | SYN | 444 | 152 | 549 | 0.0628653 | 0.8172489 | 1.33 | 0.92 | 1.92 |
| GABA-A receptors | SYN | 64 | 152 | 549 | 0.574707 | 1 | 1.37 | 0.78 | 2.40 |
| Generalized epilepsies | SYN | 177 | 152 | 549 | 0.237372 | 1 | 0.99 | 0.67 | 1.47 |
| Voltage-gated ion channels | SYN | 471 | 152 | 549 | 0.771146 | 1 | 1.19 | 0.81 | 1.74 |
| Epileptic encephalopathies | NONSYN | 259 | 152 | 549 | 0.528544 | 1 | 1.42 | 0.98 | 2.07 |
| Excitatory receptors | NONSYN | 241 | 152 | 549 | 0.708729 | 1 | 1.01 | 0.69 | 1.48 |
| Focal epilepsies | NONSYN | 142 | 152 | 549 | 0.523553 | 1 | 1.42 | 0.93 | 2.17 |
| GABAergic pathway | NONSYN | 564 | 152 | 549 | 0.442513 | 1 | 1.66 | 1.12 | 2.46 |
| GABA-A receptors | NONSYN | 63 | 152 | 549 | 0.0013633 | 0.0190862 | 2.40 | 1.41 | 4.10 |
| Generalized epilepsies | NONSYN | 194 | 152 | 549 | 0.166314 | 1 | 2.17 | 1.49 | 3.17 |
| Voltage-gated ion channels | NONSYN | 664 | 152 | 549 | 0.601852 | 1 | 1.78 | 1.17 | 2.70 |
| EpiPGX (validation) | | | | | | | | | |
| GABA-A receptors | SYN | 99 | 357 | 1485 | 0.587127 | 0.58712700 | 0.82 | 0.54 | 1.25 |
| GABA-A receptors | NONSYN | 107 | 357 | 1485 | 0.00805992 | 0.01611984 | 1.46 | 1.05 | 2.03 |
| GABA_panel (replication) | | | | | | | | | |
| GABA-A receptors* | SYN | 86 | 583 | 635 | 0.0613778 | 0.0613778 | 0,87 | 0,6 | 1,25 |
| GABA-A receptors* | NONSYN | 85 | 583 | 635 | 0.0133277 | 0.0266554 | 1,46 | 1,02 | 2.08 |

For all cohorts, the corrected and uncorrected SKAT-O P-values for different gene-sets and variant classes are given, together with the number of qualifying variants per gene-set as well as the number of cases and controls used for testing. SYN=synonymous variants. NONSYN=missense variants, OR=odds ratio, CI=confidence interval. Enriched gene-sets after applying an FDR threshold of 0.05 are marked in red. OR was calculated for only qualifying rare variants (missense or synonymous) over all genes per gene-set. Gene-sets are described in the appendix. *In the replication cohort, we used a reduced set of 15 autosomal GABA_A receptor genes because of gender QC reasons.

Table 1: Gene-set burden analysis for rare coding variants in three GGE cohorts