

Original Investigation

Rare Genetic Variants Associated With Development of Age-Related Macular Degeneration

Nicole T. M. Saksens, MD; Maartje J. Geerlings, MSc; Bjorn Bakker, BaSc; Tina Schick, MD; Mohamed R. Daha, PhD; Sascha Fauser, PhD; Camiel J. F. Boon, PhD; Eiko K. de Jong, PhD; Carel B. Hoyng, PhD; Anneke I. den Hollander, PhD

 Supplemental content at jamaophthalmology.com

IMPORTANCE Rare variants in the complement genes *CFH*, *CFI*, *C9*, and *C3* have been found to be highly associated with age-related macular degeneration (AMD); however, the effect on clinical characteristics and familial segregation by these variants is lacking.

OBJECTIVES To determine the contribution of rare *CFH* Arg1210Cys, *CFI* Gly119Arg, *C9* Pro167Ser, and *C3* Lys155Gln variants in the development of AMD in 22 multiplex families and to describe clinical differences in carriers vs noncarriers in these families and a large case-control cohort.

DESIGN, SETTING, AND PARTICIPANTS This retrospective case-control study included 114 affected and 60 unaffected members of 22 multiplex families with AMD as well as 1589 unrelated patients with AMD and 1386 unrelated control individuals enrolled in the European Genetic Database (EUGENDA). Patients were recruited from March 29, 2006, to April 26, 2013, and data were collected from April 20, 2012, to May 7, 2014. All participants underwent an extensive ophthalmic examination and completed a questionnaire. Venous blood samples were obtained from all participants for genetic analysis, including whole-exome sequencing and measurements of complement activation. Data were analyzed from September 23, 2014, to November 4, 2015.

MAIN OUTCOMES AND MEASURES Differences between carriers and noncarriers of rare variants in age at onset of symptoms, the family history of AMD, complement activation levels (C3d:C3 ratio), the presence of reticular pseudodrusen, and AMD phenotype.

RESULTS Among the 114 affected and 60 unaffected members of 22 multiplex families with AMD and the 1598 unrelated patients with AMD and 1386 controls in the EUGENDA cohort who underwent analysis, the presence of the *CFI* Gly119Arg, *C9* Pro167Ser, or *C3* Lys155Gln variant was confirmed in 18 individuals in 5 families but did not completely segregate with the disease. In the case-control cohort, the 91 affected carriers of these variants were younger at symptom onset (mean [SD] age, 67.4 [8.5] vs 71.3 [8.9] years; $P = .01$) and more often reported a positive family history (35 of 79 [44.3%] vs 367 of 1201 [30.6%]; $P = .008$) compared with the 1498 noncarriers. Patients with advanced atrophic AMD carried these rare variants more frequently than patients with neovascular AMD (11 of 93 [11.8%] vs 40 of 835 [4.8%]; $P = .04$).

CONCLUSIONS AND RELEVANCE Previously reported rare variants do not completely segregate within families with AMD. However, patients carrying these rare variants differ clinically from noncarriers by an earlier age at symptom onset, higher prevalence of a positive family history, and AMD phenotype. These results suggest that genetic tests for AMD might be designed to detect common and rare genetic variants, especially in families, because rare variants contribute to the age at onset and progression of the disease.

JAMA Ophthalmol. 2016;134(3):287-293. doi:10.1001/jamaophthalmol.2015.5592
Published online January 14, 2016.

Author Affiliations: Department of Ophthalmology, Radboud University Medical Center, Nijmegen, the Netherlands (Saksens, Geerlings, Bakker, Boon, de Jong, Hoyng, den Hollander); Department of Ophthalmology, University Hospital of Cologne, Cologne, Germany (Schick, Fauser); Department of Nephrology, Leiden University Medical Center, Leiden, the Netherlands (Daha); Department of Ophthalmology, Leiden University Medical Center, Leiden, the Netherlands (Boon); Department of Human Genetics, Radboud University Medical Center, Nijmegen, the Netherlands (den Hollander).

Corresponding Author: Anneke I. den Hollander, PhD, Department of Ophthalmology, Radboud University Medical Center, PO Box 9101, 6500 HB Nijmegen, the Netherlands (anneke.denhollander@radboudumc.nl).

Age-related macular degeneration (AMD) is the leading cause of irreversible, central visual loss in the elderly population in developed countries.¹ A combination of genetic and nongenetic factors plays a role in the development and progression of this multifactorial disease.^{2,3} Genome-wide association studies have identified common genetic risk variants that are strongly associated with AMD, such as the Tyr402His (rs1061170) variant in the complement factor *CFH* gene (HGNC 4483) and the Ala69Ser (rs10490924) variant in the age-related maculopathy susceptibility 2 (*ARMS2*) gene (HGNC 32685).^{2,4,5}

Previous family and twin studies have demonstrated a strong genetic component and aggregation of AMD within families.⁶⁻⁹ Approximately 20% to 30% of the patients have a positive family history for AMD,^{7,10-12} which has been reported as a significant risk factor for AMD. A positive family history also has been associated with an earlier age at onset of disease.¹³⁻¹⁷ Clustering of known common genetic risk factors does not fully explain the number of affected family members in large, densely affected families.⁷ Several recent studies have identified rare genetic variants that strongly increase the risk for AMD, including *CFH* Arg1210Cys, *CFI* (HGNC 5394) Gly119Arg, C9 (HGNC 1358) Pro167Ser, and C3 (HGNC 1318) Lys155Gln.^{15,18-21} These rare variants are located in genes of the complement system, which plays a major role in the pathogenesis of AMD.^{2,22} Owing to their strong effect size, these rare, highly penetrant genetic variants may account for clustering of AMD in families and lead to more severe disease. Highly penetrant variants have been identified in families with AMD, thus confirming the hypothesis that rare variants cluster in families.¹⁵⁻¹⁷ Understanding the contributions of these rare variants to the clinical characteristics of AMD is important because carrying these variants may have diagnostic, predictive, and therapeutic consequences for carriers.

The aim of the present study was to determine the contribution of known rare genetic variants in the development of AMD in large multiplex families with AMD. In addition, we aimed to describe differences in clinical characteristics in carriers compared with noncarriers of these rare genetic variants in families and a large case-control cohort.

Methods

Participants

In this retrospective study, we evaluated 114 affected and 60 unaffected members of 22 multiplex families with AMD. In addition, we analyzed a case-control cohort of 1589 unrelated patients with AMD and 1386 unrelated control individuals from the European Genetic Database (EUGENDA). This study was approved by the ethics committees of Commissie Mensgebonden Onderzoek Regio Arnhem-Nijmegen and University Hospital Cologne on research involving human subjects and met the criteria of the Declaration of Helsinki.²³ Before enrollment in EUGENDA, all participants provided written informed consent and completed a detailed questionnaire on their medical history, age at onset of first symptoms, family history of AMD, and lifestyle factors. For the case-control co-

Key Points

Question: What is the contribution of known rare genetic variants in the development of age-related macular degeneration (AMD) in large families with AMD?

Findings: Rare *CFI* Gly119Arg, C9 Pro167Ser, and C3 Lys155Gln variants were confirmed in 5 of 22 large families with AMD but did not completely segregate with the disease.

Meaning: Genetic tests for AMD might be designed to detect not only common but also rare genetic variants because rare variants appear to contribute to the age at onset and progression of the disease.

hort, a family history positive for AMD was defined as at least 2 first-degree relatives (parents and/or siblings) with AMD or possible AMD.

Patients were recruited from March 29, 2006, to April 26, 2013, and data were collected from April 20, 2012, to May 7, 2014. Each participant of the EUGENDA cohort and all members of the 22 families underwent digital color fundus photography and spectral-domain optical coherence tomography (OCT) (Spectralis; Heidelberg Engineering) after pupillary dilation. Digital, nonstereoscopic, 30° color fundus photography centered on the fovea was performed (TRC 50IX camera; Topcon Corporation). Spectral-domain OCT volume scans consisted of 19 or 37 parallel OCT B-scans for analysis, which covered a macular area of 6 × 4 mm. For each OCT B-scan, the mean of 20 images was derived using the automated real-time function.²⁴ Color fundus photographs and OCT scans of both eyes of all individuals were evaluated by 2 independent, certified reading center graders, including one of us (T.S.), according to the standard protocol of the Cologne Image Reading Center and Laboratory.²⁴ We classified AMD by the presence of pigmentary changes with at least 10 small drusen (diameter, <63 μm) or the presence of intermediate (diameter, 63-124 μm) or large (diameter, ≥125 μm) drusen in the Early Treatment Diabetic Retinopathy Study grid. Advanced AMD was defined as AMD with subfoveal geographic atrophy (GA) or choroidal neovascularization (CNV) in at least 1 eye. Age at onset of AMD was defined as the age at which the first visual symptoms occurred. Controls were classified as having no abnormalities or only small drusen or pigmentary abnormalities and were 60 years or older. In addition, in 479 individuals, infrared images and spectral-domain OCT images were evaluated for the presence of reticular pseudodrusen by one of us (T.S.).

Genotyping

Whole-exome sequencing was used to genotype 85 affected members of 22 multiplex families with AMD. The samples were sequenced at the Erasmus Medical Center using DNA obtained from venous blood after extraction using standard procedures. The DNA was fragmented using shearing ultrasonic technology according to the manufacturer's instructions (Adaptive Focused Acoustics; Covaris, Inc), and a DNA library preparation kit (Kapa Biosystems, Inc) was used on a sequencing workstation (Sciclone NGS; Caliper Life Sciences). Exome capture was achieved using

an exome solution kit (Nimblegen SeqCap EZ V2; Roche Nimblegen, Inc) designed to capture more than 44 Mb of exonic regions. Paired-end 2 × 100 sequencing was performed on a device (HiSeq2000; Illumina, Inc) using a reagent kit (TruSeq V3; Illumina, Inc). Downstream analyses included demultiplexing (CASAVA software; Illumina, Inc) and alignment to the hg19 reference genome (Genome Reference Consortium Human Reference²⁵ [http://www.ncbi.nlm.nih.gov/assembly/GCF_000001405.25/]) by the Burrows-Wheeler alignment tool.²⁶ Alignments were sorted by Picard (<http://broadinstitute.github.io/picard>) and subsequently processed using the Genome Analysis Toolkit (GATK) (indel realignment and Base-Quality Score Recalibration).²⁷ Finally, polymerase chain reaction duplicates were marked by Picard, mean depth of coverage was determined using the GATK, and Freemix values were estimated through verifyBamid.²⁸ Samples that passed technical quality control metrics were genotyped to the genomic variant call format level through the GATK haplotype caller. Insertions, deletions, and single-nucleotide variants were filtered separately using the GATK Variant-Quality Score Recalibration and annotated using the ANNOVAR tool.²⁹

We used filtering steps to select the previously associated variants in the *CFH* (Arg1210Cys; rs121913059), *CFI* (Gly119Arg; rs141853578), *C9* (Pro167Ser; rs34882957), and *C3* (Lys155Gln; rs147859257) genes from the exome files of the 85 affected family members. The annotation of the identified variants was confirmed by Sanger sequencing using primers designed with Primer3 software (<http://primer3.ut.ee>) (eTable 1 in the Supplement). The variants were also analyzed in the patients of the index families who did not carry the exome (n = 15) using Sanger sequencing.

Genotyping of the rare *CFH* Arg1210Cys, *CFI* Gly119Arg, *C9* Pro167Ser, and *C3* Lys155Gln genetic variants was performed in all 2975 included participants of the EUGENDA case-control cohort. Genotyping of the *CFI* Gly119Arg variant was performed using a custom-made assay (TaqMan; Life Technologies) as described previously.¹⁸ Genotyping of the *CFH* Arg1210Cys, *C9* Pro167Ser, and *C3* Lys155Gln variants was performed by competitive, allele-specific, polymerase chain reaction assays (KASP SNP Genotyping System; LGC Group) for *CFH* as previously described³⁰ and *C9* and *C3* according to the manufacturers' recommendations (eTable 2 in the Supplement).

Complement Measurements

Levels of complement component C3 and the activation fragment C3d were measured in serum samples as described previously.³¹ The C3d:C3 ratio was calculated as a measure of complement activation³² and is a strong marker for AMD.³¹ For the statistical analysis, the C3d:C3 ratio underwent natural logarithm transformation.

Statistical Analysis

Data were analyzed from September 23, 2014, to November 4, 2015. The odds ratio (OR) of the presence of a rare variant for AMD was calculated by binary logistic regression analysis. Statistical analyses were performed to study differences in age at symptom onset, complement activation levels, family history of AMD, and AMD subtype between patient carriers

Figure 1. Pedigrees of 5 Families With Age-Related Macular Degeneration

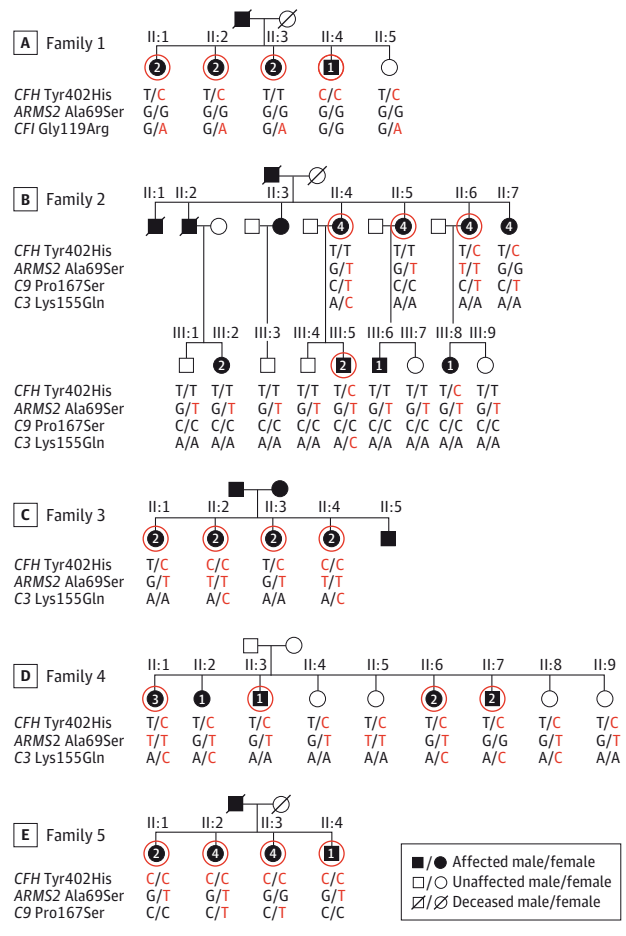

Pedigrees depict results of segregation analysis of rare and common *CFH* Tyr402His and *ARMS2* Ala69Ser variants in patients with the rare *CFI* Gly119Arg, *C9* Pro167Ser, or *C3* Lys155Gln variants of complement factor genes. Risk alleles are indicated in red. Affected individuals are assigned grades representing AMD stage (1 indicates early; 2, intermediate; 3, advanced with subfoveal geographic atrophy; and 4, advanced with choroidal neovascularization). Outer circles mark the individuals who underwent whole-exome sequencing.

and noncarriers of the rare *CFI* Gly119Arg, *C9* Pro167Ser, or *C3* Lys155Gln variant. We analyzed the mean values of the continuous traits, complement activation levels, and age at first symptoms using independent-sample *t* tests and compared the mean value using the Pearson χ^2 test for the other variables. Data were analyzed using SPSS software (version 20.0; SPSS, Inc).

Results

The rare *CFI* Gly119Arg, *C9* Pro167Ser, and *C3* Lys155Gln variants were observed in 18 individuals in 5 of the 22 multiplex families with AMD. Although these variants aggregated within these families, they did not segregate completely with the disease (Figure 1). The *CFH* Arg1210Cys variant was not observed in any of the 22 families.

Table 1. Clinical Characteristics of Carriers and Noncarriers of the Rare Variants in the 5 Families With AMD and the EUGENDA Cohort

Carrier and Disease Status	Female Sex, No. (%)	Mean (SD) Age, y		Complement Activation, Mean (SD) In C3d:C3 Ratio	No. of Patients With GA/CNV	Individuals With Reticular Drusen, No. (%)
		At Participation in EUGENDA	At Symptom Onset			
Families						
Affected carriers (n = 16)	14 (87.5)	74.9 (10.2)	63.9	1.55 (0.38)	1/5	5/16 (31.3)
Affected noncarriers (n = 9)	5 (55.6)	71.4 (8.6)	69.4	1.51 (0.40)	0/1	0
Unaffected carriers (n = 2)	2 (100)	66.0 (4.2)	NA	1.26 (0.37)	NA	0
Unaffected noncarriers (n = 8)	4 (50.0)	66.9 (5.1)	NA	1.41 (0.41)	NA	0
EUGENDA cohort						
Affected carriers (n = 91)	51 (56.0)	73.7 (8.4)	67.4	1.51 (0.35)	11/40	3/15 (20.0)
Affected noncarriers (n = 1498)	839 (56.1)	75.5 (8.9)	71.3	1.46 (0.34)	82/795	56/246 (22.8)
Unaffected carriers (n = 43)	29 (67.4)	70.2 (6.3)	NA	1.26 (0.37)	NA	0
Unaffected noncarriers (n = 1343)	764 (56.9)	70.4 (6.8)	NA	1.37 (0.36)	NA	0

Abbreviations: AMD, age-related macular degeneration; CNV, choroidal neovascularization; EUGENDA, European Genetic Database; GA, geographic atrophy; NA, not applicable.

The *CFI* Gly119Arg variant was detected in family 1 (Figure 1A). Of the 4 affected individuals, 3 were carriers of the *CFI* Gly119Arg variant. Affected individual II:4 lacked the *CFI* Gly119Arg and carried the *CFH* Tyr402His risk allele homozygously. The youngest unaffected individual (64 years) carried the risk-conferring *CFI* variant. In family 2 (Figure 1B), 2 rare variants, *C9* Pro167Ser and *C3* Lys155Gln, were identified heterozygously. Although both variants were found only in affected individuals, neither variant segregated fully with the disease phenotype. The *C3* Lys155Gln variant was found to cluster in 2 additional families (Figure 1C and D). In family 3, the *C3* Lys155Gln variant was detected in 2 affected individuals (II:2 and II:4), who also carried the *ARMS2* Ala69Ser and *CFH* Tyr402His risk alleles homozygously. Individuals II:1 and II:3 had intermediate AMD without carrying the rare variant in *C3* and were heterozygous for the common *ARMS2* Ala69Ser and *CFH* Tyr402His risk alleles. In family 4, 5 individuals carried the *C3* Lys155Gln variant, of whom 4 had AMD and 1 did not (II:8). Individuals II:6 and II:7 carried the *C3* variant and were diagnosed as having intermediate AMD. Their older siblings II:4 and II:5, who did not carry the rare variant, did not develop AMD, although they had a higher genotypic load of the 2 common variants. In addition to family 2, the *C9* Pro167Ser variant was also identified in family 5 (Figure 1E). Two affected individuals carrying the variant had a more advanced AMD stage than the affected noncarrier family members.

Within the 5 families, rare variants were detected in 16 affected individuals and 2 unaffected carriers (Table 1). Carrying 1 of the variants in *CFI*, *C9*, or *C3* resulted in an OR of 7.11 for AMD (95% CI, 1.23-40.98; $P = .03$).

The age at symptom onset was earlier in affected family members who carried the rare *CFI* Gly119Arg, *C9* Pro167Ser, or *C3* Lys155Gln variant compared with affected noncarriers (64 vs 69 years; $P = .25$) (Figure 2). The complement activation level (C3d:C3 ratio) was higher in affected family members who carried a rare variant in a complement gene compared with noncarriers (1.43 and 1.18, respectively; $P = .053$) (Figure 2). Most patients with advanced AMD carried a rare variant. This finding holds true for the single patient with GA and 5 of the patients with CNV ($P = .17$).

Five of 25 affected family members showed an AMD phenotype with reticular pseudodrusen, and all 5 patients carried the rare *CFI* Gly119Arg, *C9* Pro167Ser, or *C3* Lys155Gln variant. Carrying 1 of these variants was associated with developing reticular pseudodrusen ($P = .02$). The Pro167Ser variant in the *C9* gene appeared to segregate with the reticular pseudodrusen phenotype in family 5 because individuals II:2 and II:3, who carried the rare variant, showed reticular pseudodrusen, whereas individuals II:1 and II:4 did not. However, the rare variants in the *CFI* and *C3* genes did not segregate with the reticular drusen phenotype. Individual II:1 of family 1 and individuals II:2 and II:6 of family 4 showed the reticular pseudodrusen phenotype, but this phenotype was not observed in their siblings who carried the same rare variant.

Next, the analyses were replicated in a large case-control EUGENDA cohort, which was genotyped for the rare variants *CFH* Arg1210Cys, *CFI* Gly119Arg, *C9* Pro167Ser, and *C3* Lys155Gln. Of the 1589 patients and 1386 controls in the case-control cohort, we identified 91 carriers (5.7%) in the AMD cohort and 43 carriers (3.1%) in the control cohort (Table 1). The *CFH* Arg1210Cys variant was not present in our case-control cohort.

The presence of a rare genetic variant was associated with AMD and conferred an OR of 1.90 (95% CI, 1.31-2.75; $P = .001$). This association was comparable with the OR for advanced AMD (OR, 1.90; 95% CI, 1.27-2.85; $P = .002$). Separate analyses for each rare variant showed large effect sizes for the *CFI* Gly119Arg variant (OR, 11.38; 95% CI, 1.49-87.06; $P = .003$), whereas the effect sizes for the *C9* Pro167Ser variant (OR, 1.54; 95% CI, 0.96-2.45; $P = .07$) and the *C3* Lys155Gln variant (OR, 1.81; 95% CI, 0.96-3.44; $P = .06$) were smaller (Table 2). Patients with AMD who carried the rare *CFI* Gly119Arg, *C9* Pro167Ser, or *C3* Lys155Gln variant reported a positive family history for AMD more often than patients with AMD who did not carry these rare variants (35 of 79 [44.3%] vs 367 of 1201 [30.6%], respectively; $P = .008$). This difference in positive family history was the largest for carriers of the *CFI* Gly119Arg variant (58.3% vs 30.6%; $P = .04$), followed by variant Pro167Ser in *C9* (44.7% vs 30.6%; $P = .04$) (eTable 3 in the Supplement).

In addition, an earlier age at symptom onset was found in patients with AMD with the rare *CFI* Gly119Arg, *C9* Pro167Ser, or *C3*

Figure 2. Age at Onset and Complement Activation in Carriers vs Noncarriers of Rare Genetic Variants

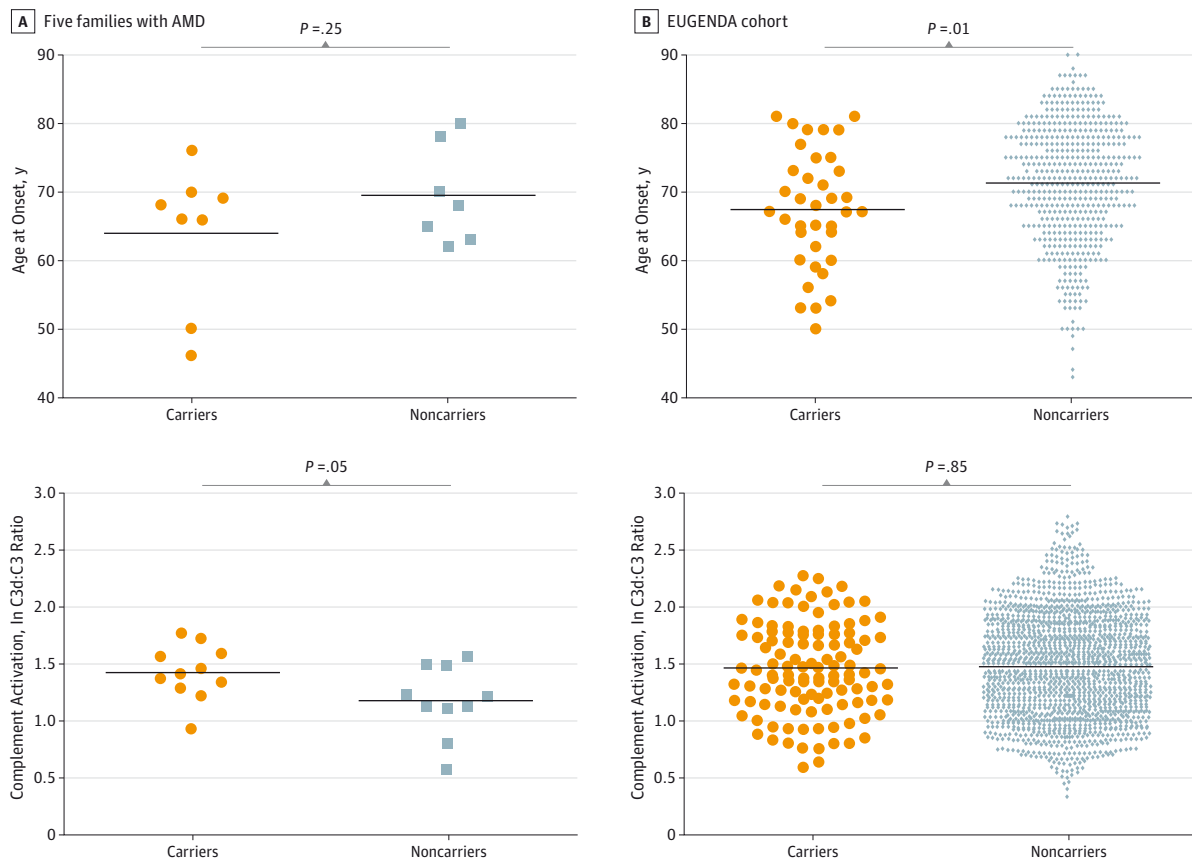

Analysis was performed in the members of 5 families with age-related macular degeneration (AMD) and in AMD cases and controls from the European Genetic Database (EUGENDA) cohort. The difference in age at onset between carriers and noncarriers was not significant in the families (mean [SD] age, 63.9 [10.3]

vs 69.4 [7.1] years) but was significant in the EUGENDA cohort (67.4 [8.5] vs 71.3 [8.9] years). The complement activation ratio between carriers and noncarriers in the families (1.427 vs 1.180) and EUGENDA cohort (1.463 vs 1.455) was not significant. Lines indicate mean values. Ln indicates natural logarithm.

Lys155Gln variant than in patients who did not carry these rare variants (mean [SD] age, 67.4 [8.5] vs 71.3 [8.9] years, respectively; $P = .01$) (Table 1 and Figure 2). In individuals carrying a rare variant, the mean complement activation level (ln C3d:C3 ratio) was higher in cases compared with controls ($P < .001$). In contrast, the mean ln C3d:C3 ratio in patients with AMD who carried one of the rare variants was not different from that of noncarriers of these variants ($P = .85$) (Figure 2). In patients with advanced AMD, the rare *CFI* Gly119Arg, *C9* Pro167Ser, and *C3* Lys155Gln variants were present more often in patients with GA (11 of 93 [11.8%]) than in patients with CNV (40 of 835 [4.8%]; $P = .04$). A reticular pseudodrusen phenotype was present in 56 of 246 patients with AMD and none of the 183 controls (Table 1). No association was found between the presence of reticular pseudodrusen and the presence of one of these rare variants in the large AMD cohort ($P = .80$).

Discussion

The development of AMD in densely affected families can be influenced by rare genetic variants, of which 4 (*CFH* Arg1210Cys,

CFI Gly119Arg, *C9* Pro167Ser, and *C3* Lys155Gln) were previously associated with AMD.^{15,18-21} In our EUGENDA case-control cohort, the presence of a variant resulted in an OR of 1.90 for AMD, which is comparable with previously reported effect sizes for the *C9* Pro167Ser and *C3* Lys155Gln variants.^{15,18-21} However, the effect size of the Gly119Arg variant in the *CFI* gene was much stronger, with an OR of 11.38, which is in line with those of previous reports (ORs, 8.5 and 22.2).^{18,33} The *CFH* Arg1210Cys variant was previously associated with AMD in North American cohorts^{15,20} but not in Icelandic¹⁹ and Han Chinese cohorts.³⁴ The absence of this variant in our AMD case-control cohort may reflect the different distribution of low-frequency alleles among populations.³⁰

Almost half of the patients who carried one of the rare *CFI* Gly119Arg, *C9* Pro167Ser, or *C3* Lys155Gln variants reported a family history positive for AMD, which has important implications for counseling of these patients and their family members and underlines the importance of including these rare variants in genetic tests for AMD. Despite their strong association with AMD in case-control cohorts,¹⁸⁻²¹ the *CFI* Gly119Arg, *C9* Pro167Ser, and *C3* Lys155Gln variants did not segregate with the disease in the 5 families in this study. This finding could point to the contribution of other genetic risk alleles and environmental factors in such

Table 2. Frequencies and Effect Sizes of the Rare Variants in the EUGENDA Cohort

Rare Variant of Complement Factor Gene	No. (%) of Participants		OR (95% CI)	P Value
	Patient Carriers (n = 1589)	Control Carriers (n = 1386)		
<i>CFI</i> Gly119Arg	13 (0.8)	1 (0.1)	11.38 (1.49-87.06)	.003
<i>C9</i> Pro167Ser	49 (3.1)	28 (2.0)	1.54 (0.96-2.45)	.07
<i>C3</i> Lys155Gln	29 (1.8)	14 (1.0)	1.81 (0.96-3.44)	.06
<i>CFH</i> Arg1210Cys	0	0		

Abbreviations: EUGENDA, European Genetic Database; OR, odds ratio.

multiplex families. Further research is warranted to determine whether additional rare variants aggregate in the remaining 17 families with AMD in this study.

Patients who carry a known rare genetic variant differ clinically from patients who do not. We demonstrated that carriers of the rare *CFI* Gly119Arg, *C9* Pro167Ser, or *C3* Lys155Gln variants have an onset of symptoms 4 years earlier, of which the *CFI* Gly119Arg variant shows the strongest effect. This finding is comparable to the earlier onset previously described in patients carrying the rare Arg1210Cys variant in the *CFH* gene¹⁵ and is in line with the earlier age at symptom onset in patients with familial AMD.¹⁴

Many of the common genetic variants associated with AMD reside in genes encoding components of the complement cascade,^{2,4,35-37} some of which have been associated with increased systemic levels of complement activation and complement components.^{25,31,38} Nearly all the recently identified rare variants are located in complement genes,^{15,17-21,39-41} emphasizing the important role of the complement system in the pathophysiology of AMD. Mean complement activation levels were slightly higher in patients with AMD who carried rare variants in the *CFI*, *C9*, or *C3* gene compared with noncarriers, but this difference in complement activation levels cannot be explained by the presence of the rare variants evaluated in this study. Preventive and therapeutic options inhibiting the complement cascade have been suggested to be effective in treating AMD,⁴² but our current results do not support the hypothesis that patients who carry a rare variant in a complement gene will benefit more from such treatments than noncarriers. However, complement inhibition is a promising target for treatment of GA in AMD,⁴³ which is more prevalent in affected carriers than noncarriers.

In this study, rare variants were more frequently identified in patients with advanced AMD and GA than advanced AMD and

GNV. This finding is in line with that of a recent study,⁴⁴ which observed a higher prevalence of GA among patients carrying the *CFH* Arg1210Cys variant. A previous investigation¹⁴ suggested that additional genetic factors may contribute to the development of GA in familial patients because a higher prevalence of GA was found in familial than sporadic AMD cases, and siblings are more likely to develop the same advanced AMD subtype as their family proband.³² The findings of the current study are thus consistent with our suggestion that additional genetic factors play a role in GA development.¹⁴

From these findings, we recommend that patients of European descent in densely affected families with AMD undergo screening for rare *CFI* Gly119Arg, *C9* Pro167Ser, and *C3* Lys155Gln variants because these rare variants played a role in more than 20% of our screened families. However, these associations may not hold true within populations of other antecedents because different rare variants in these populations may play a more important role, such as, for example, *CFH* Arg1210Cys in the North American population.¹⁹

Conclusions

We observed a higher familial occurrence and an earlier age at onset in the carriers of the rare genetic variants *CFI* Gly119Arg, *C9* Pro167Ser, and *C3* Lys155Gln. These findings emphasize the importance of counseling of patients and family members to increase awareness and enable early detection of the disease. Genetic tests for AMD should therefore be designed to detect, in addition to the common variants, the described rare genetic variants, especially in families, because these rare variants contribute to the age at onset and progression of the disease.

ARTICLE INFORMATION

Submitted for Publication: July 27, 2015; final revision received November 12, 2015; accepted November 23, 2015.

Published Online: January 14, 2016.
doi:10.1001/jamaophthalmol.2015.5592.

Author Contributions: Dr Saksens and Ms Geerlings contributed equally to this study. Dr den Hollander had full access to all the data in the study and takes responsibility for the integrity of the data and the accuracy of the data analysis.

Study concept and design: Saksens, Geerlings, Boon, de Jong, Hoyng, den Hollander.

Acquisition, analysis, or interpretation of data: Saksens, Geerlings, Bakker, Schick, Daha, Fauser, Boon, de Jong, den Hollander.

Drafting of the manuscript: Saksens, Geerlings, Boon, Hoyng.

Critical revision of the manuscript for important intellectual content: All authors.

Statistical analysis: Saksens, Geerlings.

Obtained funding: Hoyng, den Hollander.

Administrative, technical, or material support: Saksens, Geerlings, Bakker, Schick, Fauser.

Study supervision: Schick, Daha, Boon, de Jong, Hoyng, den Hollander.

Conflict of Interest Disclosures: All authors have completed and submitted the ICMJE Form for Disclosure of Potential Conflicts of Interest and none were reported.

Funding/Support: This study was supported by grant agreement 310644 (MACULA) from the

European Research Council under the European Union's Seventh Framework Programme (FP/2007-2013), grant C-GE-0811-0548-RAD04 from the Foundation Fighting Blindness USA, Nederlandse Oogonderzoek Stichting, Diana Hermens Stichting, MD Fonds, Oogfonds, Algemene Nederlandse Vereniging ter Voorkoming van Blindheid, Stichting Nederlands Oogheelkundig Onderzoek, and Gelderse Blindenstichting.

Role of the Funder/Sponsor: The funding sources had no role in the design and conduct of the study; collection, management, analysis, and interpretation of the data; preparation, review, or approval of the manuscript; and decision to submit the manuscript for publication.

Previous Presentation: This study was presented at the Molecular Biology of AMD session at the 2015 Annual Meeting of the Association for Research in Vision and Ophthalmology; May 6, 2015; Denver, Colorado.

Additional Contributions: Joannes M. M. Groenewoud, MSc, Department for Health Evidence, Radboud University Medical Center, provided support for the statistical analyses. He received no additional compensation for this role.

REFERENCES

- Friedman DS, O'Colmain BJ, Muñoz B, et al; Eye Diseases Prevalence Research Group. Prevalence of age-related macular degeneration in the United States. *Arch Ophthalmol*. 2004;122(4):564-572.
- Fritsche LG, Chen W, Schu M, et al; AMD Gene Consortium. Seven new loci associated with age-related macular degeneration. *Nat Genet*. 2013;45(4):433-439. doi:10.1038/ng.1232
- Age-Related Eye Disease Study Research Group. Risk factors associated with age-related macular degeneration: a case-control study in the Age-Related Eye Disease Study: Age-Related Eye Disease Study report number 3. *Ophthalmology*. 2000;107(12):2224-2232.
- Klein RJ, Zeiss C, Chew EY, et al. Complement factor H polymorphism in age-related macular degeneration. *Science*. 2005;308(5720):385-389.
- Chen W, Stambolian D, Edwards AO, et al; Complications of Age-Related Macular Degeneration Prevention Trial Research Group. Genetic variants near *TIMP3* and high-density lipoprotein-associated loci influence susceptibility to age-related macular degeneration. *Proc Natl Acad Sci U S A*. 2010;107(16):7401-7406.
- Heiba IM, Elston RC, Klein BE, Klein R. Sibling correlations and segregation analysis of age-related maculopathy: the Beaver Dam Eye Study. *Genet Epidemiol*. 1994;11(1):51-67.
- Klaver CC, Wolfs RC, Assink JJ, van Duijn CM, Hofman A, de Jong PT. Genetic risk of age-related maculopathy: population-based familial aggregation study. *Arch Ophthalmol*. 1998;116(12):1646-1651.
- Klein ML, Mauldin WM, Stoumbos VD. Heredity and age-related macular degeneration: observations in monozygotic twins. *Arch Ophthalmol*. 1994;112(7):932-937.
- Luo L, Harmon J, Yang X, et al. Familial aggregation of age-related macular degeneration in the Utah population. *Vision Res*. 2008;48(3):494-500.
- Seddon JM, Ajani UA, Mitchell BD. Familial aggregation of age-related maculopathy. *Am J Ophthalmol*. 1997;123(2):199-206.
- Meyers SM, Greene T, Gutman FA. A twin study of age-related macular degeneration. *Am J Ophthalmol*. 1995;120(6):757-766.
- Saksens NT, Fleckenstein M, Schmitz-Valckenberg S, et al. Macular dystrophies mimicking age-related macular degeneration. *Prog Retin Eye Res*. 2014;39:23-57.
- Shahid H, Khan JC, Cipriani V, et al; Genetic Factors in AMD Study Group. Age-related macular degeneration: the importance of family history as a risk factor. *Br J Ophthalmol*. 2012;96(3):427-431.
- Saksens NT, Kersten E, Groenewoud JM, et al. Clinical characteristics of familial and sporadic age-related macular degeneration: differences and similarities. *Invest Ophthalmol Vis Sci*. 2014;55(11):7085-7092.
- Raychaudhuri S, Iartchouk O, Chin K, et al. A rare penetrant mutation in *CFH* confers high risk of age-related macular degeneration. *Nat Genet*. 2011;43(12):1232-1236.
- Ratnapriya R, Zhan X, Fariss RN, et al. Rare and common variants in extracellular matrix gene Fibrillin 2 (*FBN2*) are associated with macular degeneration. *Hum Mol Genet*. 2014;23(21):5827-5837.
- Yu Y, Triebwasser MP, Wong EK, et al. Whole-exome sequencing identifies rare, functional *CFH* variants in families with macular degeneration. *Hum Mol Genet*. 2014;23(19):5283-5293.
- van de Ven JP, Nilsson SC, Tan PL, et al. A functional variant in the *CFI* gene confers a high risk of age-related macular degeneration. *Nat Genet*. 2013;45(7):813-817.
- Helgason H, Sulem P, Duvvari MR, et al. A rare nonsynonymous sequence variant in *C3* is associated with high risk of age-related macular degeneration. *Nat Genet*. 2013;45(11):1371-1374.
- Zhan X, Larson DE, Wang C, et al. Identification of a rare coding variant in complement 3 associated with age-related macular degeneration. *Nat Genet*. 2013;45(11):1375-1379.
- Seddon JM, Yu Y, Miller EC, et al. Rare variants in *CFI*, *C3* and *C9* are associated with high risk of advanced age-related macular degeneration. *Nat Genet*. 2013;45(11):1366-1370.
- Schramm EC, Clark SJ, Triebwasser MP, Raychaudhuri S, Seddon JM, Atkinson JP. Genetic variants in the complement system predisposing to age-related macular degeneration: a review. *Mol Immunol*. 2014;61(2):118-125.
- World Medical Association. World Medical Association Declaration of Helsinki: ethical principles for medical research involving human subjects. *JAMA*. 2013;310(20):2191-2194. doi:10.1001/jama.2013.281053.
- Mokwa NF, Ristau T, Keane PA, Kirchhof B, Satta SR, Liakopoulos S. Grading of age-related macular degeneration: comparison between color fundus photography, fluorescein angiography, and spectral domain optical coherence tomography. *J Ophthalmol*. 2013;2013:385915.
- Reynolds R, Hartnett ME, Atkinson JP, Giclas PC, Rosner B, Seddon JM. Plasma complement components and activation fragments: associations with age-related macular degeneration genotypes and phenotypes. *Invest Ophthalmol Vis Sci*. 2009;50(12):5818-5827.
- Li H, Durbin R. Fast and accurate short read alignment with Burrows-Wheeler transform. *Bioinformatics*. 2009;25(14):1754-1760.
- McKenna A, Hanna M, Banks E, et al. The Genome Analysis Toolkit: a MapReduce framework for analyzing next-generation DNA sequencing data. *Genome Res*. 2010;20(9):1297-1303.
- Jun G, Flickinger M, Hetrick KN, et al. Detecting and estimating contamination of human DNA samples in sequencing and array-based genotype data. *Am J Hum Genet*. 2012;91(5):839-848.
- Wang K, Li M, Hakonarson H. ANNOVAR: functional annotation of genetic variants from high-throughput sequencing data. *Nucleic Acids Res*. 2010;38(16):e164.
- Duvvari MRSN, Saksens NT, van de Ven JP, et al. Analysis of rare variants in the *CFH* gene in patients with the cuticular drusen subtype of age-related macular degeneration. *Mol Vis*. 2015;21:285-292.
- Smalhodzic D, Klaver CC, Klevering BJ, et al. Risk alleles in *CFH* and *ARMS2* are independently associated with systemic complement activation in age-related macular degeneration. *Ophthalmology*. 2012;119(2):339-346.
- Röther E, Lang B, Coldewey R, Hartung K, Peter HH. Complement split product C3d as an indicator of disease activity in systemic lupus erythematosus. *Clin Rheumatol*. 1993;12(1):31-35.
- Alexander P, Gibson J, Cree AJ, Ennis S, Lotery AJ. Complement factor I and age-related macular degeneration. *Mol Vis*. 2014;20:1253-1257.
- Shen SK, Liu XQ, Lu F, Yang ZL, Shi Y. Association study between age-related macular degeneration and R1210C mutation of *CFH* gene in Chinese population [in Chinese]. *Zhonghua Yi Xue Yi Chuan Xue Za Zhi*. 2012;29(5):570-572.
- Maller J, George S, Purcell S, et al. Common variation in three genes, including a noncoding variant in *CFH*, strongly influences risk of age-related macular degeneration. *Nat Genet*. 2006;38(9):1055-1059.
- Hughes AE, Orr N, Esfandiary H, Diaz-Torres M, Goodship T, Chakravarthy U. A common *CFH* haplotype, with deletion of *CFHR1* and *CFHR3*, is associated with lower risk of age-related macular degeneration. *Nat Genet*. 2006;38(10):1173-1177.
- Maller JB, Fagerness JA, Reynolds RC, Neale BM, Daly MJ, Seddon JM. Variation in complement factor 3 is associated with risk of age-related macular degeneration. *Nat Genet*. 2007;39(10):1200-1201.
- Hecker LA, Edwards AO, Ryu E, et al. Genetic control of the alternative pathway of complement in humans and age-related macular degeneration. *Hum Mol Genet*. 2010;19(1):209-215.
- Hoffman JD, Cooke Bailey JN, D'Acoust L, et al. Rare complement factor H variant associated with age-related macular degeneration in the Amish. *Invest Ophthalmol Vis Sci*. 2014;55(7):4455-4460.
- Duvvari MR, Paun CC, Buitendijk GH, et al. Analysis of rare variants in the *C3* gene in patients with age-related macular degeneration. *PLoS One*. 2014;9(4):e94165.
- Boon CJ, Klevering BJ, Hoyng CB, et al. Basal laminar drusen caused by compound heterozygous variants in the *CFH* gene. *Am J Hum Genet*. 2008;82(2):516-523.
- Volz C, Pauly D. Antibody therapies and their challenges in the treatment of age-related macular degeneration. *Eur J Pharm Biopharm*. 2015;95(pt B):158-172.
- Rhoades W, Dickson D, Do DV. Potential role of lapanizumab for treatment of geographic atrophy. *Clin Ophthalmol*. 2015;9:1049-1056.
- Ferrara D, Seddon JM. Phenotypic characterization of complement factor H R1210C rare genetic variant in age-related macular degeneration. *JAMA Ophthalmol*. 2015;133(7):785-791.