

# REAL-TIME COMPENSATION OF HYSTERESIS AND CREEP IN PIEZOELECTRIC ACTUATORS

Hartmut Janocha, Klaus Kuhnen, Saarbrücken

Laboratory for Process Automation (LPA), University of Saarland, Germany,

Im Stadtwald, Gebäude 13, D-66041 Saarbrücken

## **Abstract**

An approach for the simultaneous compensation of the hysteretic and creep transfer characteristics of a piezoelectric stack actuator by interposing an inverse system in an open loop control is described. The basis of the inverse control paradigm is formed by complex creep and hysteresis operators. Both operators consist of weighted superpositions of elementary operators which can easily be described mathematically and which reflect the qualitative properties of the transfer characteristic. This operator-based actuator model allows the prediction of the transfer characteristic within the inverse control paradigm in order to calculate the compensation signal in real-time. As a result, the maximum linearity error caused by hysteresis and creep effects is lowered by an order of magnitude.

**Keywords:** piezoelectric actuator, hysteresis, creep, nonlinear compensation, inverse control

## 1 Introduction

Piezoelectric solid-state actuators are capable of almost immediately transforming electric into mechanical energy or vice versa, and are therefore used in industry as both highly dynamic actuators and fast sensors. Especially when used as actuators, in which high-level driving voltages  $x(t)$  are used to generate the greatest possible displacements  $y(t)$ , the electro-mechanical transfer behaviour is characterized by creep and hysteretic effects; see Fig. 1.

That leads to ambiguities in the transfer behaviour of piezoelectric energy actuators and thus to a considerable reduction of the repeatability attainable in an open-loop control paradigm. Today, in practice, this disadvantage can be avoided by adjusting the position of the actuator within a closed-loop control paradigm. This model, however, requires an additional displacement sensor to determine the output quantity, a controller to generate the plant input, calibration of the displacement sensor as well as a complicated controlling adjustment mechanism. The present paper describes an alternative solution based upon the compensation for non-ideal transfer characteristics by interposing an inverse system in an open-loop control paradigm; see Fig. 2.

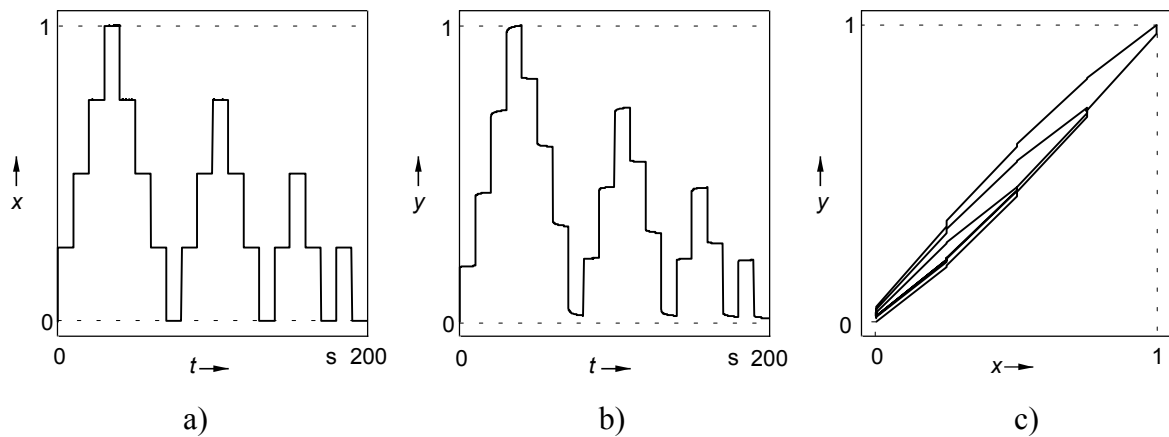

**Fig. 1:** Electromechanical transfer characteristic of a piezoelectric transducer as an actuator:

- Electrical excitation  $x(t)$ , normalized on the maximum amplitude.
- Mechanical reaction  $y(t)$ , normalized on the maximum amplitude.
- Mechanical reaction  $y$  over the electrical excitation  $x$ .

For that end, an operator  $\Gamma_a[\cdot]$  is developed to describe the hysteretic and creeping large-signal transfer characteristic of the actuator simultaneously.

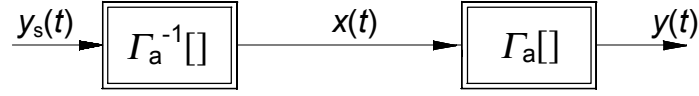

**Fig.2:** Signal flow chart of the hysteresis and creep-free control

Based on this operator, a numerical procedure will be given to realize the inverse operator

$$x(t) = \Gamma_a^{-1}[y_s(t)] \quad (1)$$

in real-time for use as a feed-forward controller of the actuator. Here  $y_s(t)$  is the given control signal of the system.

## 2 Theoretical fundamentals

In the mathematical literature, the notation of the hysteretic nonlinearity is equated with the notation of the so called "rate-independent memory effect" [8]. This means that the output signal of a system with hysteresis depends not only on the present value of the input signal but also on the order of their past amplitudes, especially the extremum values, but not on the rate in the past. The rate-independent branching transfer characteristic is typical for a system with hysteretic nonlinearities. Because of its phenomenological character, the concept of hysteresis operators developed by Krasnosel'skii and Pokrovskii in the 1970s allows a very general and precise modeling of hysteretic system behaviour [5]. The basic idea consists in the modeling of the real hysteretic transfer characteristic by a weighted superposition of many elementary hysteresis operators, which differ according to the type of the elementary operator in one or more parameters.

As a physical example, Fig. 3 shows a cylindrical piston tube C of length  $r$  and a piston P. Both elements can move along one direction, the piston being the driver and the tube the driven element. The position of the piston is characterized by the coordinate  $x$  of point A, and

the position of the cylindrical tube by the coordinate  $\eta_r$  of point B. If the position of the piston  $x$  is considered as the input signal and the position of the tube  $\eta_r$  as the output signal, the output-input trajectory in the  $\eta_r, x$ -plane shows the hysteretic branching characteristic as in Fig. 3b.

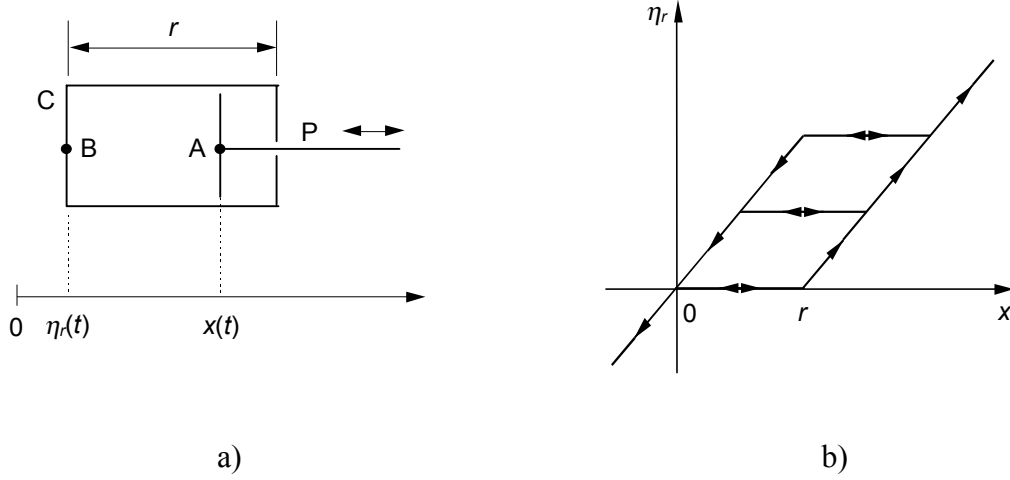

**Fig. 3:** Linear-play operator: a) Physical model b) Rate-independent transfer characteristic

Such an elementary hysteresis system is referred to as a linear-play operator [2]

$$\eta_r(t) = p_r[x(t), \eta_r(t_0), x(t_0)]. \quad (2)$$

The operator is characterized by its threshold parameter  $r$  which stands for the tube length in the physical example. The initial value of the operator state, namely the pair  $(\eta_r(t_0), x(t_0))$ , determines in a clear manner the value of the operator output  $\eta_r(t)$  in relation to the future values of the input signal  $x(t)$ . For the precise modeling of real hysteresis phenomena, several linear-play operators with different threshold values  $r_i$  can be superimposed. This parallel connection of elementary hysteresis operators leads to the complex hysteresis operator

$$y_h(t) = H[x(t)] = \sum_{i=1}^n q_i \cdot p_{r_i}[x(t), \eta_{r_i}(t_0), x(t_0)]. \quad (3)$$

The notation of creep originally comes from the field of solid mechanics and describes the time-variant deformation behaviour of a body due to the application of a sudden mechanical load [6]. It is a strongly damped, rate-dependent phenomenon which can also be found in

ferromagnetism and ferroelectricity. Like hysteresis phenomena, which can be recognized by the difference between the ascending and descending signals in Fig. 1b, the electrically induced creep effects have a considerable influence on the large-signal transfer characteristic of a piezoelectric actuator. If these creep phenomena are linear, they can be described, analogously to the hysteresis modeling process, by a complex linear creep operator

$$y_c(t) = L[x(t)] = \sum_{j=1}^m c_j \cdot l_{\lambda_j}[x(t), z_{\lambda_j}(t_0)], \quad (4)$$

which is comprised of a weighted superposition of many elementary linear creep operators

$$z_{\lambda}(t) = l_{\lambda}[x(t), z_{\lambda}(t_0)] := e^{\lambda(t-t_0)} \cdot z_{\lambda}(t_0) + \int_{t_0}^t e^{\lambda(t-\tau)} \cdot \lambda \cdot x(\tau) d\tau \quad (5)$$

with different creep eigenvalues  $\lambda$ . In this case the elementary linear creep operator represents the analytical solution of a linear first-order differential equation with an initial state value  $z_{\lambda}(t_0)$ . Fig. 4a shows a physical interpretation in solid mechanics (Kelvin-Voigt model) and Fig. 4b describes the step response of the elementary linear creep operator, which has the same qualitative properties as the step response of the creep phenomena in the real system.

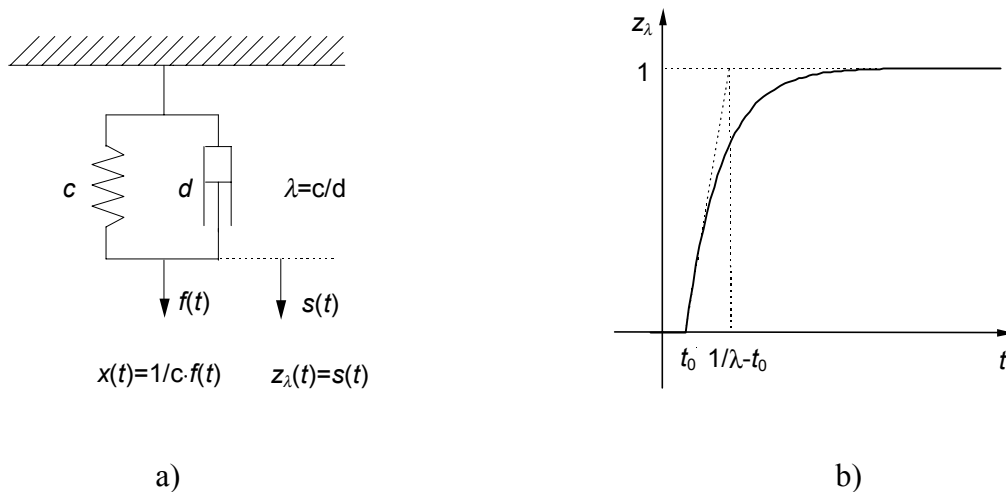

**Fig. 4:** Elementary linear creep operator: a) Physical model b) Step response

The linear creep model introduced before describes the creep behaviour of piezoelectric actuators very accurately, starting from a known initial state after the excitation with a step

function [4]. It fails, however, when the dependence of the creep effects on the past history of the input signal must be considered. In this context the question arises: does in which way the past history of the input signal influence the creep behaviour of the actuator ? To answer this question, we need to consider the following observation: The piezoelectric actuator reacts to an electrical excitation (which is globally comprised of many local signal steps) with a displacement signal (which is analogously composed of many local step responses); see Figs. 1a and 1b. Each local step response can be divided into a part with a direct and a part with a delayed reaction. We can thus use a complex linear creep operator which is controlled by a signal  $x_h(t)$  and additively superimposed by another signal  $y_h(t)$  to describe the output signal  $y(t)$  within a local time interval; see Fig. 5.

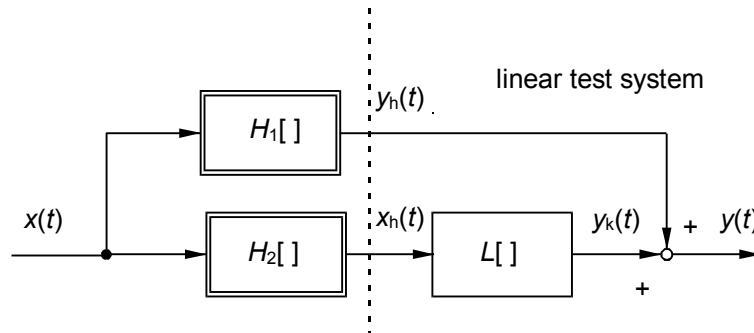
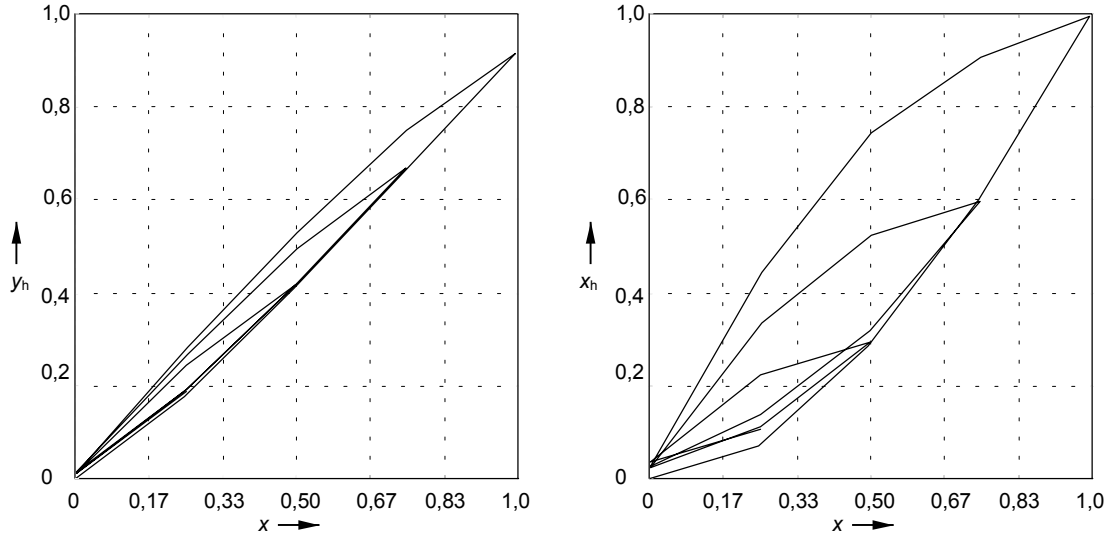

**Fig. 5:** Model of a creep and hysteretic piezoelectric actuator

The least squares method and standard procedures of linear regression analysis allow the reconstruction of those signal values  $x_h(t)$  and  $y_h(t)$  which generate the output signal  $y(t)$  after the excitation of a linear test system for every partial interval. Fig. 6 shows the signals  $y_h(t)$  and  $x_h(t)$  versus the real input signal  $x(t)$  of the actuator, which have been reconstructed on the basis of the reaction of the actuator  $y(t)$  in Fig. 1b. It becomes obvious that the signals  $y_h(t)$  or  $x_h(t)$  and the actual input signal  $x(t)$  are, at least approximately, connected by a multi-valued rate-independent transfer characteristic, which is typical for hysteretic systems. We thus conclude that the nonlinear creep behaviour of the piezoelectric actuator can be described, at least approximately, by the series combination of a complex hysteresis operator  $H_2[]$  and a complex linear creep operator  $L[]$ , and the hysteretic deformation part by the parallel connection of another complex hysteresis operator  $H_1[]$ . Therefore, the model of the piezoelectric actuator can be expressed by the operator

$$y(t) := \Gamma_a[x(t)] = L[H_2[x(t)]] + H_1[x(t)] . \quad (6)$$

For systems which can be described in a sufficiently precise way by a pure, strictly monotone complex hysteresis operator, an inverse operator can be derived directly from the system model [2,7].



**Fig. 6:** The characteristic between the reconstructed signals  $x_h$  and  $y_h$  and the input signal  $x$

But here the operator  $\Gamma_a[\cdot]$  contains complex hysteresis operators and a complex linear creep operator that act together, and so the system operator cannot simply be directly inverted. Therefore, the inverse system model has to be carried out numerically. Sufficient conditions for the existence and uniqueness of an inverse operator  $\Gamma_a^{-1}[\cdot]$  and thus for the convergence of the numerical inversion procedure are the continuity and strong monotonicity of the operator  $\Gamma_a[\cdot]$  [3]. Because of the continuity of the linear-play operator and the linear creep operator, the operator  $\Gamma_a[\cdot]$  is also continuous. Because of the monotonicity of the linear-play operator with a threshold value  $r \neq 0$ , and the strong monotonicity of the elementary linear creep operator and the linear-play operator with a threshold value  $r = 0$ , the monotonicity property of the operator  $\Gamma_a[\cdot]$  depends only on the values of the weights  $q_i$  and  $c_j$ . Therefore, the identification of weights has to be carried out with constraints which guarantee the strong monotonicity and thus the invertibility of the operator  $\Gamma_a[\cdot]$ .

### 3 Time-discrete inverse control of the piezoelectric stack actuator

To calculate the inverse control signal in real-time a digital signal processor (DSP) is used. Therefore a time-discrete model for the operator  $\Gamma_a[\cdot]$  is developed. After assuming a digital control with zero-order sample and hold circuits, the input signal of the real actuator remains constant between two sampling points. Because of the rate-independent transfer characteristic of a complex hysteresis operator, the input signal  $x_h(t)$  of the complex linear creep operator is constant, too. With this thought in mind we solve the integral equation (5) analytically and replace it by a simple first order difference equation

$$z_\lambda(k+1) = e^{\lambda T_s} \cdot z_\lambda(k) + (1 - e^{\lambda T_s}) \cdot x(k)$$

(7)

with

$$l_\lambda[x(k)] = z_\lambda(k),$$

which can be calculated very quickly by a digital signal processor. Here  $T_s$  is the sample time. A procedure for the fast numerical calculation of the linear-play operator and thus a time-discrete model for digital signal processing applications follows from basic geometric considerations based on the simple physical model shown in Fig. 3 [2]. Starting with the consistency condition  $x(0) \leq \eta_r(0) \leq x(0) + r$  for the initial value of the operator state, the linear-play operator can be calculated by the difference equation

$$\eta_r(k) = \begin{cases} x(k) & , \text{ if } \eta_r(k-1) > x(k) \\ \eta_r(k-1) & , \text{ if } \eta_r(k-1) \leq x(k) \leq \eta_r(k-1) + r \\ x(k) - r & , \text{ if } \eta_r(k-1) + r < x(k) \end{cases}$$

(8)

with

$$p_r[x(k)] = \eta_r(k) .$$

In practice due to the continuity of the linear-play operator complex hysteresis loops can be modeled in a sufficiently precise way with the help of a small number of elementary operators [1]. Analogously, the local creep curves in Fig. 1b can be modeled in a sufficiently precise way with the help of a small number of elementary linear creep operators [3]. Therefore, both the complex hysteresis operator  $H[\cdot]$  and the complex linear creep operator  $L[\cdot]$  are suitable



tools for the real-time calculation of real hysteresis and linear creep phenomena. Hence and thanks to the simple structure of the operator  $\Gamma_a[\cdot]$ , its calculation can be carried out in an a-priori stable manner and very quickly by a DSP in real-time.

Fig. 7 shows the signal flow chart of the iterative inversion procedure to realize the inverse operator  $\Gamma_a^{-1}[\cdot]$  numerically. In this procedure two system models, an iteration model  $\Gamma_a^{it}[\cdot]$  and a reference model  $\Gamma_a^{ref}[\cdot]$ , are used.

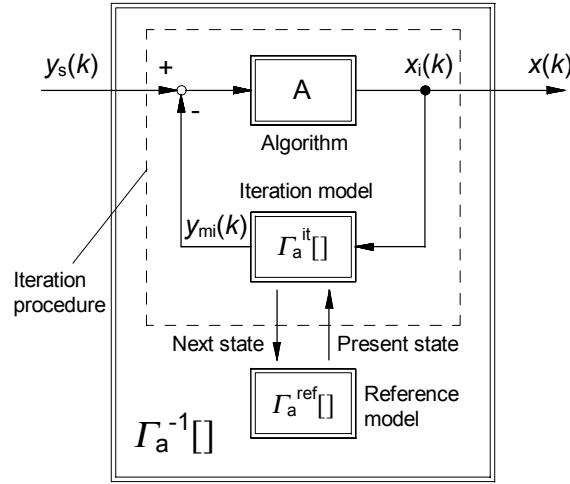

**Fig. 7:** Signal flow chart of the iterative inversion procedure

Assuming that the real system, the iteration model and the reference model have the same state, an estimated value  $x_i(k)$  for the inverse control signal  $x(k)$  is attained using the algorithm represented by block A. With that, the real system reaction  $y(k)$  due to the estimated inverse control signal value  $x_i(k)$  is predicted by the output value  $y_{mi}(k)$  of the iteration model  $\Gamma_a^{it}[\cdot]$ . Then the predicted system reaction  $y_{mi}(k)$  is compared with the given control signal value  $y_s(k)$ . If the difference between  $y_s(k)$  and  $y_{mi}(k)$  is not sufficiently small, the algorithm block A calculates an improved inverse control signal value  $x_{i+1}(k)$  based on the value  $x_i(k)$ . Since the state of the iteration model  $\Gamma_a^{it}[\cdot]$  has changed by the calculation of  $y_{mi}(k)$ , it must be reconstructed by the reference model for the next iteration step. If the difference between  $y_s(k)$  and  $y_{mi}(k)$  is small enough, the iteration procedure stops and the real system is driven with the inverse control signal  $x(k) = x_i(k)$ . In this case, the state of the real system is the same as the state of the iteration model  $\Gamma_a^{it}[\cdot]$ , and thus the state of the reference model  $\Gamma_a^{ref}[\cdot]$  must be updated with the state of the iteration model  $\Gamma_a^{it}[\cdot]$ .

## 4 Results and Discussion

To evaluate the quality of the new model with regard to the modeling of the real creep and hysteresis characteristics, the electromechanical transfer characteristic was measured on a piezoelectric stack actuator. For this case the actuator was electrically excited by the test signal  $x(t)$  shown in Figure 8a, and the mechanical reaction  $y(t)$  of the actuator was measured with the help of a high precision laser interferometer. In system theory, the response of a hysteretic system to the test signal shown in Figure 8a is called first-order reversal curves, because they exhibit a strong branching characteristic due to the oscillating course of the excitation. This is typical for hysteretic systems and is made clear through this form of excitation. Caused by creep effects in the transfer characteristic, the hysteresis loops run through a stabilization process at the beginning of the excitation. The complex hysteresis operators  $H_1[]$  and  $H_2[]$  were built up of 10 linear-play operators with fixed threshold values  $r_i$ . The complex linear creep operator  $L[]$  consists of 5 elementary linear creep operators with fixed eigenvalues  $\lambda_j$ ; see Tab. 1-3. The parameters  $c_j$  in the complex creep operator and the parameters  $q_i$  in the complex hysteresis operator were identified by using conventional nonlinear optimization procedures (for example, the method of the steepest descent) to minimize the deviation between the measured and modeled transfer characteristics.

$r_1$	0,0	$q_1$	+0,918
$r_2$	0,1	$q_2$	+0,0559
$r_3$	0,2	$q_3$	+0,0888
$r_4$	0,3	$q_4$	+0,00244
$r_5$	0,4	$q_5$	+0,0833
$r_6$	0,5	$q_6$	+0,00264
$r_7$	0,6	$q_7$	+0,0523
$r_8$	0,7	$q_8$	-0,0151
$r_9$	0,8	$q_9$	+0,0163
$r_{10}$	0,9	$q_{10}$	-0,00498

**Tab. 1:** Parameter of the hysteresis operator  $H_1[]$

$r_1$	0,0	$q_1$	+1,00
$r_2$	0,1	$q_2$	+0,488
$r_3$	0,2	$q_3$	-0,0448
$r_4$	0,3	$q_4$	-0,0741
$r_5$	0,4	$q_5$	+0,0853
$r_6$	0,5	$q_6$	-0,0630
$r_7$	0,6	$q_7$	-0,00263
$r_8$	0,7	$q_8$	+0,129
$r_9$	0,8	$q_9$	+0,136
$r_{10}$	0,9	$q_{10}$	+0,149

**Tab. 2:** Parameter of the hysteresis operator  $H_2[\ ]$

$\lambda_1$	0,03	$c_1$	+0,0664
$\lambda_2$	0,3	$c_2$	+0,0748
$\lambda_3$	3	$c_3$	+0,0556
$\lambda_4$	30	$c_4$	+0,0721
$\lambda_5$	300	$c_5$	+0,0448

**Tab. 3:** Parameter of the linear creep operator  $L_1[\ ]$

In Fig. 8b the normalized measured values of the actuator reaction  $y$ , resulting from the excitation signal  $x$  in Fig. 8a, are shown as circles versus the time  $t$ ; while Fig. 8c presents the normalized measurement values of the displacement  $y$  against the exciting normalized voltage  $x$ . Apart from the measurement values, Fig. 8b and Fig. 8c also show the output-input characteristic calculated on the basis of the new models. Fig. 8d finally compares the error signal  $e$  between the real system response and the one calculated with the help of the new model, as well as the error signal  $e$  between the real system response and the one calculated with the help of a linear characteristic.

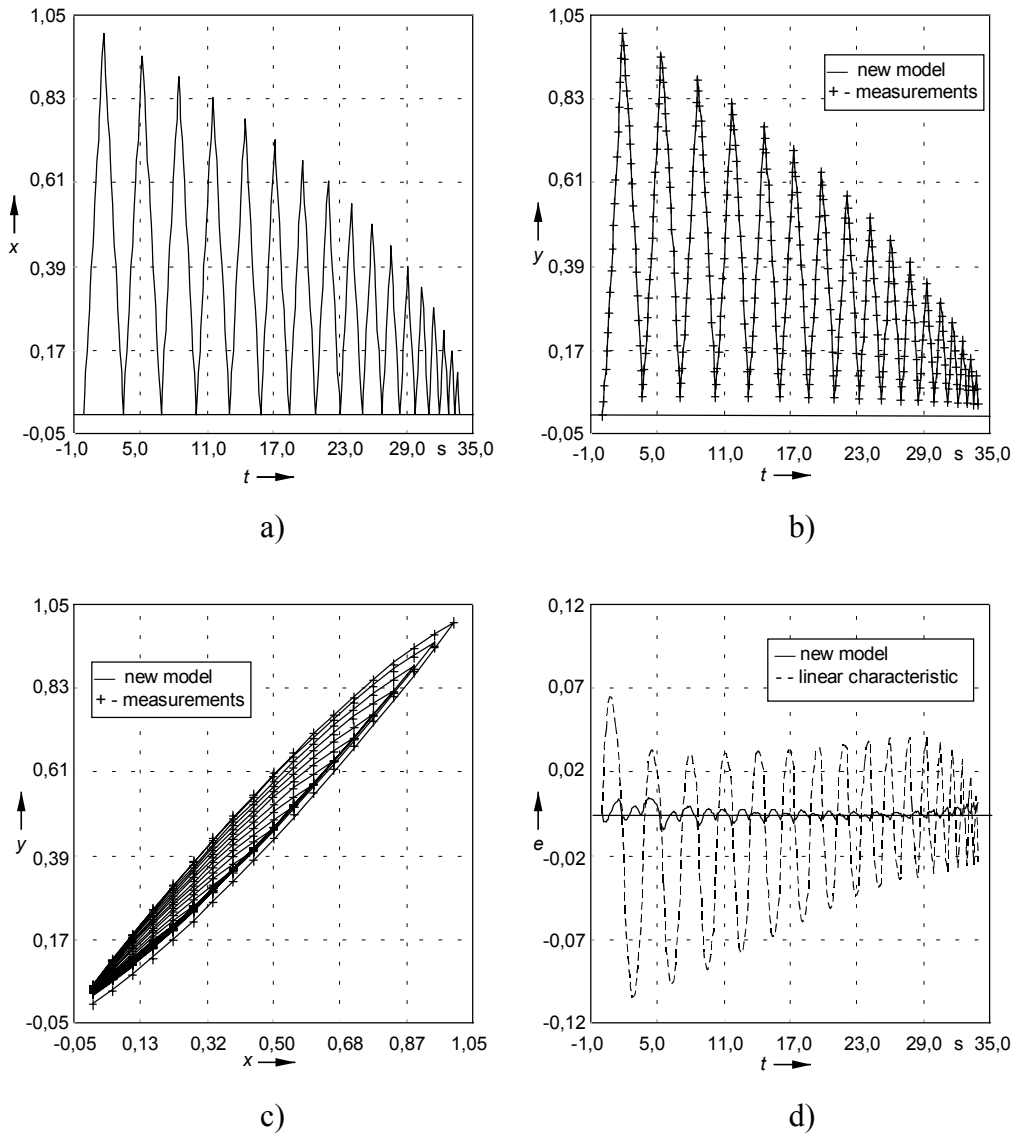

**Fig. 8:** Actuator reaction  $y(t)$  on the signal  $x(t)$  and model error  $e(t)$ :

a) Input signal  $x(t)$  b) System reaction  $y(t)$  c) System reaction  $y(x)$  d) Model error  $e(t)$

Fig. 8b gives a clear idea of the drifting of the output signal caused by dynamic creep processes. Fig. 8c, however, shows the strong branching characteristic, typical for hysteretic systems. Fig. 8b shows that the operator  $\Gamma_a[\cdot]$  models exactly the creep behaviour of the actuator reaction. But also the hysteresis characteristic, which becomes clearer in Fig. 8c, is described in exact accordance with the measurement values. When a linear characteristic is used, the error signal  $e$  shows two significant qualities, which are caused by the hysteresis and creep effects in the real characteristic of the actuator typical for the large-signal operation. First, due to the hysteresis effects, the error signal is to a great extent dependent on the

amplitude of the excitation signal. Second, due to the creep phenomena, it shows significant fluctuations. The error signal of the new model lacks these undesirable qualities. With the new model there is no significant inequality in the error signal between large-signal and small-signal control. While the error signal  $e$  in the case of a linear characteristic reaches up to 11 % of the maximum amplitude at full modulation, the new model reduces these values to 1 %. This corresponds to an improvement by one order of magnitude.

To verify the performance of the inverse control procedure, the inverse system was implemented on a DSP TMS 320C40 and was driven with the same input signal  $y_s(t)$  as shown in Fig. 8a. The calculation time of the control is less than 1ms and so a sampling frequency greater than 1kHz is possible.

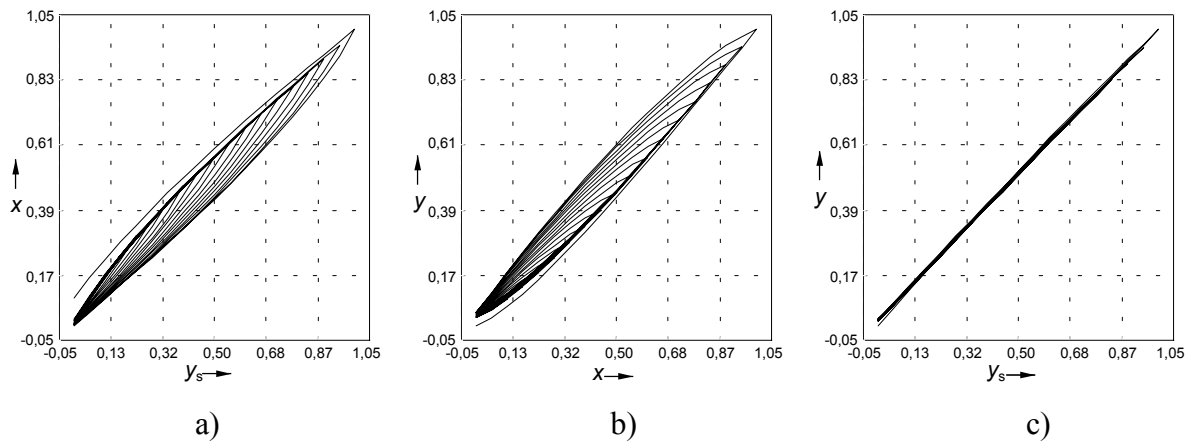

**Fig. 9:** Results of the inverse control process: a) Inverse control signal  $x$  versus the given control signal  $y_s$  b) Output signal  $y$  versus the inverse control signal  $x$  c) Output signal  $y$  versus the given control signal  $y_s$

Fig. 9a shows the output-input characteristic of the inverse system. The curves run through an inverse stabilization process due to the consideration of the creep effects by the complex creep model  $L[H_2[]]$  and show an inverse branching behaviour due to the consideration of hysteresis effects by the complex hysteresis operator  $H_1[]$ . Fig. 9c presents the output-input characteristic of the serial connection of the inverse system and the real system. Due to the compensation effect of the inverse control the stabilization process and the branching behaviour caused by the creep and hysteresis phenomena are strongly reduced. In the case of the inverse control

paradigm the relative deviation of the transfer characteristic from an optimal linear characteristic, which is caused by the model error, amounts to only 1%.

### **Summary and prospects**

This paper shows that complex creep and hysteresis operators offer an efficient method for the simultaneous and real-time modeling and inverse control of systems with hysteretic and creep transfer characteristics. In future work this method will be extended to systems with more than one input signal. Thanks to this method, the additionally multi-valued influence of an external mechanical load on the displacement can be considered and compensated.

### **Acknowledgements**

The authors thank the Deutsche Forschungsgemeinschaft (DFG) for financial support of this work.

### **References**

- [1] Bergqvist, A.: On magnetic hysteresis modeling. Royal Institute of Technology, Electric Power Engineering, Stockholm, Sweden (1994).
- [2] Brokate, M.; Sprekels, J.: Hysteresis and Phase Transitions. Springer-Verlag, Berlin, Heidelberg, New York, (1996).
- [3] Janocha, H.; Kuhnen, K.: Ein neues Hysterese- und Kriechmodell für piezoelektrische Wandler. *at-Automatisierungstechnik* 46, (1998), 493-500.
- [4] Kortendieck, H.: Entwicklung und Erprobung von Modellen zur Kriech- und Hysteresis-korrektur. VDI Verlag, Düsseldorf, (1993).
- [5] Krasnosel'skii, M. A.; Pokrovskii, A. V.: Systems with hysteresis. Springer-Verlag, Berlin, (1989).
- [6] Lemaitre, J.; Chaboche, J.L.: Mechanics of solid materials. Cambridge University Press, New York New Rochelle Melbourne Sydney, (1990).
- [7] Schäfer, J.; Janocha, H.: Compensation of hysteresis in solid state actuators. *Sensors and Actuators A* 49, (1995), 97-102.
- [8] Visintin, A.: Differential models of hysteresis. Springer-Verlag, Berlin Heidelberg New York, (1996).

## **Biographies**

Hartmut Janocha (Prof. Dr.-Ing. habil.), born in 1944, studied electrical engineering at the University of Hanover. Since 1989, he has been head of the Laboratory for Process Automation (LPA) at the University of Saarland in Saarbrücken, Germany. Here, the main fields of work are new actuators with system and signal-processing concepts, calibration methods for improving the positioning accuracy of industrial robots and measurement of 3D-geometry using CCD video cameras.

Klaus Kuhnen (Dipl.-Ing.), born in 1967, studied electrical engineering at the University of Saarland. Following graduation, he has been working there as a scientific collaborator at the Laboratory for Process Automation (LPA) in the fields of solid-state actuators and digital signal processing.