

Real-Time Nonintrusive Monitoring And Prediction Of Driver Fatigue

Aarthi K.J. Veronica*¹, Nandhini. S.K², Hema Pavithra.S³, Hemalatha. D⁴, Keerthana.R⁵

¹Assistant Professor, Department of ECE, R.M.K College of Engineering and Technology, Tamilnadu, India

²UG Scholar, Department of ECE, R.M.K College of Engineering and Technology, Tamilnadu, India

³UG Scholar, Department of ECE, R.M.K College of Engineering and Technology, Tamilnadu, India

⁴UG Scholar, Department of ECE, R.M.K College of Engineering and Technology, Tamilnadu, India

⁵UG Scholar, Department of ECE, R.M.K College of Engineering and Technology, Tamilnadu, India

ABSTRACT

Passively monitoring a driver's activities constitutes the basis of an automobile safety system that can potentially reduce the number of accidents by estimating the driver's focus of attention. In this project a complete accident avoidance system is proposed by determining the driver's behavior. As the main causes of vehicle accident were related to human factors, they could be labeled in one of the main driver's distraction categories such as drowsiness, yawning and distracted vision. The main causes of the traffic accidents, discovered in the analysis of the driver behavior with the help of our system, will be used for the development of assistant devices and alarm systems that could help the driver to avoid risky situations. In this project we are implementing two image processing tool to get the facial geometry based on Viola Jones algorithm and skin color face detection method combined tracking. Frequencies of eye blinking and eye closure are used as the indication of sleepy and warning sign is then generated for recommendation, secondly outside an ego vehicle, road traffic is also analyzed. BP sensor is introduced to check the heart-beat of the driver, if any variation occurs in heart beating stop the car. Ultrasonic sensor is used to measure distance in front of cars. Break failure also detected.

Keywords-Viola Jones algorithm, skin color face detection method, Ultrasonic sensor, BP sensor

1. INTRODUCTION

The goal of this project is to develop a camera-based system for monitoring the activities of automobile drivers. As in any system deployed for monitoring driver activities, the primary goal is to distinguish between safe and unsafe driving actions.[1] An application that motivates this work is objective reporting of a driver's activities over long driving periods, in contrast with subjective reports based on surveys.[10] Another interesting application is in the area of interior vehicle design, where such information helps improve the placement of controls in order to reduce unsafe driving behaviors.

There is no fixed list of actions that qualify as unsafe driving behaviors the skin-tone regions of the input video are used as the features in the classifiers.[3] Binary skin-tone masks are agglomerated across an entire action sequence to assign a probability of observing skin tones for each pixel in the image during the action.[2] Action sequences are separated from one another by detecting substantial movements in the image, signified by large differences between the skin-tone masks of sequential frames.[4] In the supervised method, key frames corresponding to safe driving actions and unsafe driving actions are specified by the user.[1] These key frames are used for obtaining the subspace densities corresponding to an individual action.[6] In this work, talking on a cellular telephone is classified as an unsafe action. A Bayesian Eigen-image method is used for classifying the activities.

2. EXISTING SYSTEM

In Existing System, although several accident avoidance systems have already been deployed in the vehicles they were seem to be less efficient and costlier compared to our proposed system. Driver distraction is mainly taken as a big issue in current situation. In previous eye blink sensor are utilized for identify the drowsiness detection. But in the efficiency wise it

difficult to wear and also affect the eye. Also automatic braking systems have not been employed in the existing automobile systems.

3. SYSTEM DESCRIPTION

3.1 Face Detection Techniques

Face detection techniques can be categorized into two major groups that are feature based approaches and image based approaches. Image based approaches use linear subspace method, neural networks and statistical approaches for face detection. Feature based approaches can be subdivided into low level analysis, feature analysis and active shape model.

3.1.1 Viola-Jones Face Detection

Viola-Jones technique is based on exploring the input image by means of sub window capable of detecting features. This window is scaled to detect faces of different sizes in the image. Viola Jones developed a scale invariant detector which runs through the image many times, each time with different size. Being scale invariant, the detector requires same number of calculations regardless of the size of the image.

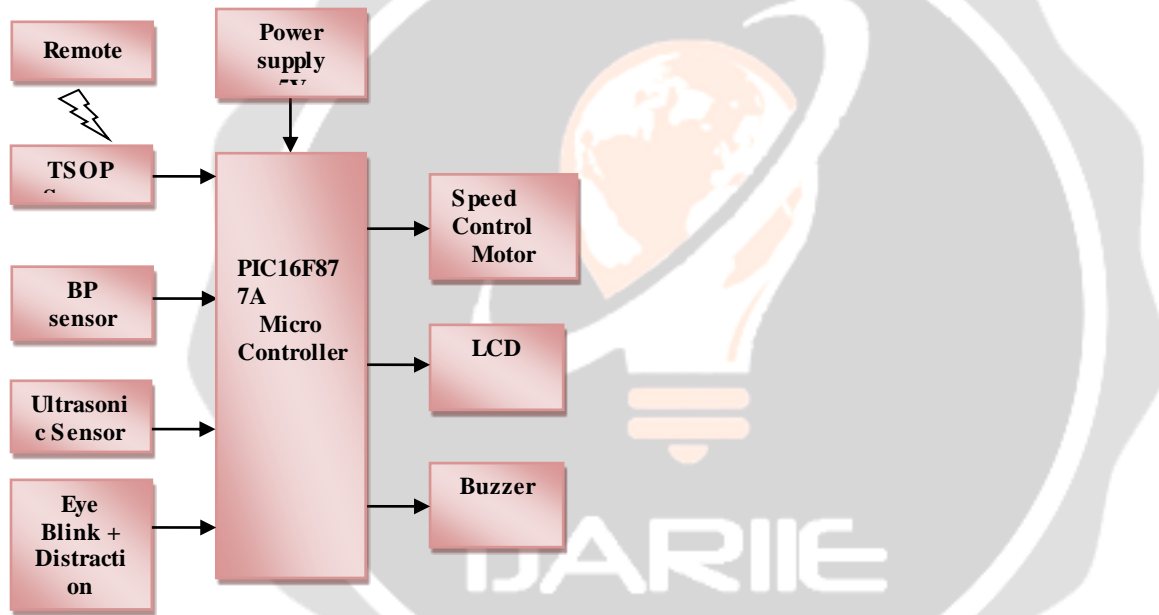

Fig 1: Overview of the drivers fatigue prediction

In fig. 1 the interface between the software output and the hardware components. Different sensors used here are ultrasonic sensor and bp sensor. Minimum distance of the vehicle is sensed by ultrasonic sensor. Bp sensor is implemented to sense the number of pulse per minute. Output of the sensors are fed to microcontroller from which LCD displays the output. Buzzer is activated as a warning signal. In order to show in a real-time scenario we use a speed motor that is controlled by TSOP sensor.

The system architecture of Viola Jones is based on a cascade of detectors. The first stages consist of simple detectors which eliminates only those windows which do not contain faces. In the following stages the complexity of detectors are increased to analysis the features in more detail. A face is detected only if it is observed through the entire cascade. These detectors are constructed from integral image and Haar.

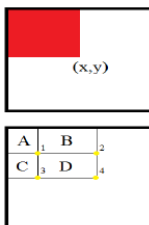
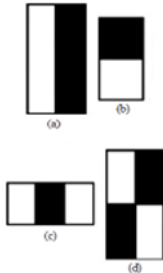

Fig 2: Conversion of input image to integral image

The first step of this algorithm is to convert the input image into an integral image as shown in fig. 2. This is done by making each pixel equal to the entire sum of all pixels above and to the left of the concerned pixel. By doing so, sum of all pixels inside any given rectangle can be calculated using only four values.

**Fig 3:** Viola Jones Haar like features

Sum of the rectangle ABCD = D-(B + C) + A. The face detector in Viola Jones method analyzes a sub-window using features. These features consist of two or more rectangles. Each feature gives a single resultant value which is calculated by subtracting the sum of the white rectangle(s) from the sum of the black rectangle(s). Different types of features are shown in fig 3.

Viola and Jones used a simple classifier built from computationally efficient features using AdaBoost for feature selection. AdaBoost is a machine learning boosting algorithm that constructs a strong classifier through a weighted combination of weak classifiers.

The Viola - Jones method for face object detection contains three techniques:

- Integral image for feature extraction the Haar-like features is rectangular type that is obtained by integral image
- Ad a boost is a machine-learning method for face detection. The word boosted means that the classifiers at every stage of the cascade are complex themselves and they are built out of basic classifiers using one of four boosting techniques (weighted voting).
- Cascade classifier used to combine many features efficiently. The word cascade in the classifier name means that the resultant classifier consists of several.

$$\sum_{1 \leq i \leq N} \sum_{1 \leq j \leq N} I(i,j) 1_{P(i,j) \text{ is white}} - \sum_{1 \leq i \leq N} \sum_{1 \leq j \leq N} I(i,j) 1_{P(i,j) \text{ is black}}$$

Simpler classifiers (stages) that are applied subsequently to a region of interest until at some stage the candidate is rejected or all the stages are passed. Finally, the model can obtain the non-face region and face region after cascading each of strong classifiers.

Viola-Jones face detection algorithm scans the detector several times through the same image –each time with a new size. The detector detects the non-face area in an image and discards that area which results in detection of face area. To discard non face area Viola Jones take advantage of cascading. When a sub window is applied to cascading stages, each stage concludes whether the sub window is a face object or not. Sub windows which contain some percentage of having faces are passed to next stage and those which are not faces are discarded. Final stage is considered to have a high percentage of face objects.

3.1.2 Skin Color Pixel Detection Technique

Second method used for face detection is based on skin color face detection method. In face detection approaches detection of skin color is first step. Major advantages of this technique are its robustness, non-sensitivity to position and shape invariance. However for this technique to work, it is vital to use an accurate color space model. Some existing color spaces are RGB, CMY, XYZ, UVW, LSLM, L*a*b*, L*u*v*, LHC, LHS, HSV, HSI, YUV, YIQ, YCbCr out of which Most commonly RGB, HIS, YCbCr are used. We are using RGB color space for skin color detection as it is native representation of color images and it is widely used for processing and storing digital images. RGB color space consist of three basic colors R (red), G(green), B(blue) that can be combined to produce any resultant color. Although different people have different skin colors, studies have shown that actual difference lies between the intensities. So if Brightness is removed from color representation, the difference

between human skin colors can be reduced. In order to detect skin color following set of rules have been found to be more accurate than other models.

$(R > 95) \text{ AND } (G > 40) \text{ AND } (B > 20)$
 (first condition)

$\text{AND } (\max - \min > 15) \text{ AND } (|R - G| > 15)$
 $\text{AND } (R > G) \text{ AND } (R > B) \text{ AND } (R > 220) \text{ AND}$
 $(G > 210) \text{ AND } (B > 170) \text{ AND } (R > B) \text{ AND } (G > B)$
 (2)

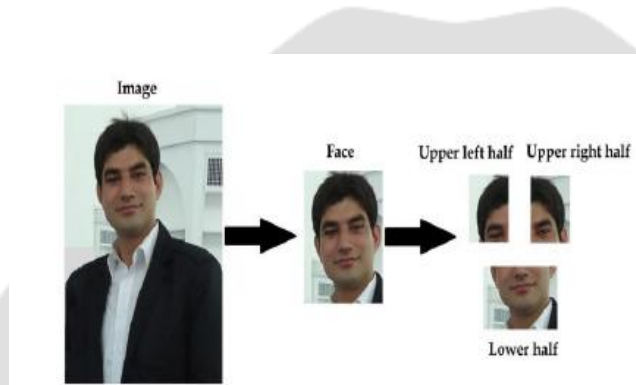

Fig 4: Face image division based on physical approximation of location of eyes and mouth on face

Pixels of RGB image are detected as skin if first condition holds true and rest of the conditions are used to ensure that RGB components must not be close together, that ensures grayness elimination. It also ensures that R and G component must not be together which must be true for fair complexion R is largest in R, G and B for pixel of skin color regions in RGB color space and B maybe be larger than G for pixels of skin color regions in the shadow. These rules are suitable for detection of skin color under regular illumination conditions as well as in shadow. The resultant image from this technique is a black and white image in which skin is converted to white and rest of the colors are converted to black. Face can be detected then by cutting the biggest white connected area with in black and white image.

3.1.3 Hybrid Detector Design

The hybrid design consists of three phases is shown in fig. 5. In phase one face is detected. Skin color pixel detection is used to extract all the entire skin color pixels from the image. Once they are extracted Viola Jones is applied to detect face. This increases efficiency of Viola Jones techniques and decreases consumed time. In second phase the face detected is extracted from input image for further processing. Extracted face image is divided into three sub portions upper left half, upper right half and lower half.

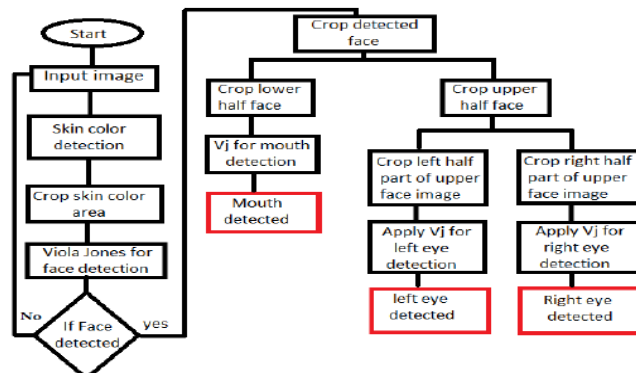

Fig 5: Hybrid design flow chart for face eyes and mouth detection

3.2 Viola Jones Upper Body Objects Detection

Accurate upper body object detection improves the robustness of face and reduces the challenging task of object detecting upper bodies from unconstrained still images and video.

The cascade object detector uses the Viola-Jones face detection algorithm to detect people's upper body and face object detection. The model detects the upper-body region, which is defined as the head and shoulders area as well as reorganization of upper body and face object. This model uses Haar features and object detection to encode the details of the head and shoulder region. Because it uses more features around the head and face object, this model is more robust against pose/image changes, e.g. head rotations/eye blinking tilts To Detect Upper Body in an Image Using the Upper Body Classification Model.

- Create a detector object and set properties.
- Read input image and detect upper body.
- Annotate detected upper bodies.

3.2.1 Viola-Jones Face Objects Detection Algorithm

Early efforts in face object detection have dated back as early as the beginning of the 1970s, where simple heuristic and anthropometric techniques Face detection techniques can be categorized into two major groups that are feature based approaches and image based approaches. Image and video based approaches use linear subspace method, neural networks and statistical approaches for face object detection. Face feature based approaches can be subdivided into low level and high level analysis, feature analysis and active shape model analysis. Face detection is controlled by special trained scanning window classifiers Viola-Jones Face Detection Algorithm is the first real-time face detection system.

3.2.2 Viola-Jones Eye Detection Algorithm

Eyes are detected based on the hypothesis that they are darker than other part of the face, finding eye analogue segments searching small patches in the input image that are roughly as large as an eye and are darker than their neighbourhoods. a pair of potential eye regions is considered as eyes if it satisfies some constraints based on anthropological characteristics of human eyes .To discard regions corresponding to eyebrows, the model uses the fact that the centre part of an eye region is darker than other parts. Then a simple histogram analysis of the region is done for selecting eye regions since an eye region should exhibit two peaks while an eyebrow region shows only one. A final constraint is the alignment of the two major axis, so the two eye regions belong to the same line. The study propose a new algorithm for eyes' detection that uses Iris geometrical information for determining the whole image region containing an eye, and then applying the symmetry for selecting both eyes.

3.2.3 Viola-Jones Mouth Detection Algorithm

Detection and Extraction features from the mouth region; this model is composed of weak classifiers, based on a decision stump, which uses Haar features to encode mouth details. Experimental results show that the algorithm is Face image division based on physical approximation of location of eyes, nose and mouth on face and can find out the mouth region rapidly. It is useful in a wide range; moreover, it is effectual for complex background such as public mouth detection.

3.3 Gaze Detection

Face and facial features detection has been an active research area in the computer vision field as it has large number of application such as biomedical image analysis human computer interfaces monitoring and surveillance , smart rooms intelligent robots image database management system and drivers alertness system.

A vast amount of research is performed in the field of face and facial components detection, localization and tracking. Generally, we can classify these approaches into four main groups. (1)Feature invariant approaches: Invariant features, (passive to brightness, and position) are utilized in this approach to detect faces. The relations among face features and the presence of the detected faces are usually described by building up a statistical model. Such face features are Skin Color, Texture and Facial features. (2) Template matching method: This technique involves comparison of portions of images against one another. A pattern matching operation is done between the template containing human face and input image. Examples of this method are active Shape Model and shape template. (3) Knowledge-based method: in this method the position of the face is localized by

finding the invariant feature of the face. Analogy among the features determines the presence of human face in an input image. (4)Appearance-based method: In this method a series of face images are trained that establish a face model for face detection such as Neural Network and Hidden Markov Model.

Face detection proposed by Viola and Jones based on statistic methods is most popular among the face detection approaches. This face detection is a variant of the AdaBoost algorithm which achieves rapid and robust face detection. They proposed a face detection method based on the AdaBoost learning algorithm using Haar features that detected the face successfully with high accuracy. However the accuracy of the method is still not enough when this method is used to detect facial feature. In our research we have integrated Viola Jones, skin color pixel detection and physical location approximation technique to have a hybrid design which can detect face, mouth and eyes more accurately while consuming less time.

4. EXPERIMENTS

4.1 Matlab Output

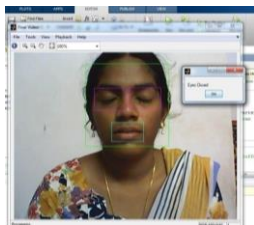

Fig 6: Eyes closed



Fig 7: Mouth open

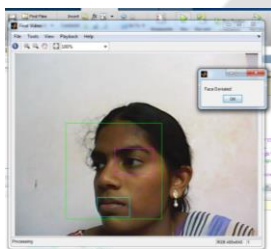

Fig 8: Face deviated



Fig 9: Normal frame

Once a sequence of sample videos are captured the pixel variations are noted and a suitable threshold value is assigned that would decide the state of the driver. On the next run, frames in which the pixel values exceed those pre-assigned threshold values will be alerted with eyes closed, mouth open or face deviated commands prompting the driver. The focus is on eyes, mouth and the face which are denoted in the form of a rectangular box in pink, green and green respectively as shown in fig. 9 as normal frame. The above cases are shown in fig. 6, fig. 7 and fig. 8 respectively.

EYES	MOUTH	FACE
1274	530	12455
1328	431	15372
1468	512	13612
Threshold value : 1700	Threshold value : 600	Threshold value : 20000

Table 1: Setting the threshold values

4.2 Hardware Output



Fig 10: Initial Setup of ACCIDENT AVOID**Fig 11:** Display of distance measured

In order to create a scenario of moving car we are using a speed motor that is operated using a remote via TSOP Sensor. Left top of fig. 10 is ultrasonic sensor and left bottom is the speed motor. Right bottom of fig. 10 is the buzzer that would alarm the driver when the distance is reduced due to obstacle. The remote provides the 4 different speeds by just pressing the number keys in it like the gear we have in car.

**Fig 12:** Display when driver fatigue

In fig. 10 we are able to observe the initial setup of the driver's gaze monitoring and in fig. 11 we see the speed at which the motor is driven here the number '4' key in remote and distance of closeness by another vehicle in real-time scenario is found as 'D009'. The ultrasonic sensor rays are obstructed and buzzer starts to ring and a 'L.Dist' keyword is observed in the LCD display.

Fig. 12 is the final stage of our project that indicates what would happen when the pixel variations exceed the threshold values and how it is received at the back end. The PIC controller would provide a signal display of 'DROWSY' while the output measured exceeds the threshold values when the motor is running. The live video capturing is continuously monitored while the speed motor is in running state.

This would indicate the driver to apply the brake or to pay attention towards the road travelling. Thus the use of Viola Jones face detection and assigning of threshold values helped us in arriving a solution to driver's fatigue (gaze detection). Hardware incorporation to the detection method made us to study and arrive at better results.

5. CONCLUSION

This paper describes the methodology for driver aided system and helps to reduce the accidents occurred due to fatigue detection. Our proposed system's installation does not require any additional theoretical development irrespective of car models. In addition it keeps track of car pace so that we can avoid accidents due to over speed driving, car crashing. The experiments showed that our head pose estimation algorithm is robust to extreme facial deformations. In future, we will integrate

eye information, when available, to further disambiguate confusion between adjacent gaze zones. We would also like to incorporate other body parts analysis such as hand directly with gaze zones for the driver activity analysis.

REFERENCES

- [1] Brian F. Towler, Ashok Kumar Chejara, and Saeid Mokhatab, University of Wyoming, USA .
- [2] Brodeur, P.H.; Gerhardtstein, J.P.; Overview of applications of ultrasonics in the pulp and Paper industry Ultrasonics Symposium, 1998. Proceedings., 1998 IEEE Volume 1, 5-8 Oct. 1998 Page(s):809 - 815 vol.1
- [3] Francisco Vicente, Zehua Huang, Xuehan Xiong, Fernando De la Torre, Wende Zhang, and Dan Levi, "Driver Gaze Tracking and Eyes Off the Road Detection System" in IEEE Transactions on Intelligent Transportation Systems 2014.
- [4] Lex Fridman, Philipp Langhans, Joonbum Lee, And Bryan Reimer, "Driver Gaze Region Estimation Without Using Eye Movement"
- [5] Max Praglin, Bryant Tan, "Eye Detection And Gaze Estimation"
- [6] Moran Cerf, Jonathan Harel, Wolfgang Einhauser, Christof Koch, "Predicting Human Gaze Using Low-Level Saliency Combined With Face Detection"
- [7] Paolo De Luna, Mohamed Faiz Bin Mohamed Mustafar, Gregor Rainer, "A Matlab-Based Eye Tracking Control System Using Non-Invasive Helmet Head Restraint In The Macaque"
- [8] Sameer Bhide, Arjun Seshadri, and Brian Williams, "Facial Feature Detection and Gaze Tracking" in Clemson University, ECE 847.
- [9] Satish Pandey, Dharmendra Mishra, Anchal Srivastava, Atul Srivastava, R. K. Shukla Department of Physics, University of Lucknow, Lucknow, India.
- [10] Sediment T. Ebinuma, K. Suzuki, J. Nagao, H. Oyama, and H. Narita, Methane Hydrate Research Laboratory, Ultrasonic Wave Velocities Associated with Formation and Dissociation of Methane Hydrate in Artificial Sandy.
- [11] Tawari and Mohan M. Trivedi, "Robust and Continuous Estimation of Driver Gaze Zone by Dynamic Analysis of Multiple Face Videos" in IEEE Intelligent Vehicles Symposium 2014.
- [12] Vanes Sah Ugot, "Eye Gaze Analysis In Human-Human Interactions"
- [13] Wobschall, D., Zeng, M., Srinivasaraghavan, B. An Ultrasonic/Optical Pulse Sensor for Precise Distance Measurements
- [14] Zhihong Wang, Weiguang Zhu, Jianmin Mia, Hong Zhu, Chen Chao, Ooi Kiang Tan, Sch. of Electr. & Electron. Eng., Nanyang Technol. Univ., Singapore; Micromachined thick film piezoelectric ultrasonic Transducer array.
- [15] Zope Chaitali K.1, Y. C. Kulkarni, "Driver Aided System Using Open Source Computer Vision" in International Journal of Innovative Research in Computer and Communication Engineering 2015.