



Provided by the author(s) and University College Dublin Library in accordance with publisher policies. Please cite the published version when available.

Title	Real-time recognition and profiling of appliances through a single electricity sensor
Authors(s)	Ruzzelli, Antonio G.; Nicolas, C.; Schoofs, Anthony; O'Hare, G. M. P. (Greg M. P.)
Publication date	2010-06
Publication information	2010 7th Annual IEEE Communications Society Conference on Sensor Mesh and Ad Hoc Communications and Networks (SECON) [proceedings]
Conference details	Paper presented at Sensor Mesh and Ad Hoc Communications and Networks (SECON), 2010 7th Annual IEEE Communications Society Conference, Boston, Massachusetts, 21-25 June, 2010
Publisher	IEEE
Link to online version	http://dx.doi.org/10.1109/SECON.2010.5508244
Item record/more information	http://hdl.handle.net/10197/3505
Publisher's statement	Personal use of this material is permitted. Permission from IEEE must be obtained for all other uses, in any current or future media, including reprinting/republishing this material for advertising or promotional purposes, creating new collective works, for resale or redistribution to servers or lists, or reuse of any copyrighted component of this work in other works.
Publisher's version (DOI)	10.1109/SECON.2010.5508244

Downloaded 2022-08-23T13:05:39Z

The UCD community has made this article openly available. Please share how this access benefits you. Your story matters! (@ucd_oa)



Real-Time Recognition and Profiling of Appliances through a Single Electricity Sensor

A.G. Ruzzelli, C. Nicolas[†], A. Schoofs, and G.M.P. O’Hare

CLARITY: Centre for Sensor Web Technologies

School of Computer Science and Informatics, University College Dublin, Ireland

[†]Institute of Higher Education in Computer Science and Communication,

University of Rennes, France

{ruzzelli, anthony.schoofs, gregory.ohare}@ucd.ie

clement.nicolas@etudiant.univ-rennes1.fr

Abstract—Sensing, monitoring and actuating systems are expected to play a key role in reducing buildings overall energy consumption. Leveraging sensor systems to support energy efficiency in buildings poses novel research challenges in monitoring space usage, controlling devices, interfacing with smart energy meters and communicating with the energy grid. In the attempt of reducing electricity consumption in buildings, identifying individual sources of energy consumption is key to generate energy awareness and improve efficiency of available energy resources usage. Previous work studied several non-intrusive load monitoring techniques to classify appliances; however, the literature lacks of an comprehensive system that can be easily installed in existing buildings to empower users profiling, benchmarking and recognizing loads in real-time. This has been a major reason holding back the practice adoption of load monitoring techniques. In this paper we present **RECAP: RECOgnition of electrical Appliances and Profiling in real-time**. RECAP uses a single wireless energy monitoring sensor easily clipped to the main electrical unit. The energy monitoring unit transmits energy data wirelessly to a local machine for data processing and storage. The RECAP system consists of three parts: (1) Guiding the user for profiling electrical appliances within premises and generating a database of unique appliance signatures; (2) Using those signatures to train an artificial neural network that is then employed to recognize appliance activities (3) Providing a Load descriptor to allow peer appliance benchmarking. RECAP addresses the need of an integrated and intuitive tool to empower building owners with energy awareness. Enabling real-time appliance recognition is a stepping-stone towards reducing energy consumption and allowing a number of major applications including load-shifting techniques, energy expenditure breakdown per appliance, detection of power hungry and faulty appliances, and recognition of occupant activity. This paper describes the system design and performance evaluation in domestic environment.

I. INTRODUCTION

Electricity represents 41% of the total energy used in American homes [1]. The delivered energy use per household declines at an average annual rate of 0.6 percent, mostly due to technological progress in power efficiency [2]. To further increase that trend, smart energy grids are being promoted to address optimal management and improved control of energy, by introducing intelligence into the electricity grid. The recent momentum for Smart Grid meters, visible in a number of government driven large-scale pilot deployments such as in

Italy [11] and in the US [12], intends to accelerate their introduction into households.

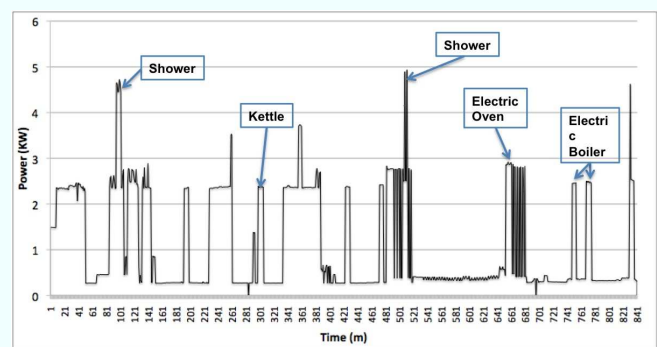

Fig. 1. Typical energy consumption in domestic premises

Within this context, embedded sensor networks and actuating systems are expected to play a key role in monitoring and reducing building’s overall energy consumption. Recent standardization efforts have generated a push towards the integration of sensor systems in building automation systems and home environments. IEEE 802.15.4, ZigBee [16], and IETF 6LoWPAN/ROLL [5], [6] are enabling technologies that facilitates the connections of low-cost sensing and monitoring units and gather energy consumption information in real-time. Low-power wireless networking has enabled easy access to households meter readings, making them available to energy utilities for monitoring and control, and to building owners for direct feedback on their energy consumption e.g. Ted energy detective [14]. Fine-grained energy decomposition is nevertheless not available. Key is to process the energy data to finally provide meaningful information to empower building owners with hints for reducing their energy cost. To this end, providing a breakdown of the energy expenditure per appliance is of particular interest to identify energy hungry devices and provide other interesting services to the homeowner (e.g. home activity patterns).

Figure 1 shows typical domestic energy consumption over a time period with some appliance activity annotations. The

main aim of this work is to develop a low-cost system that can attribute names to appliances contributing to each of the energy spikes in real time with a single energy monitor. In this paper, we present Real-time Electrical Appliance Recognition (RECAP), a system that provides fine-grained recognition of appliances in real-time, based on one single Zigbee-based building energy monitor attached to the main electrical unit. RECAP system components are appliance signature profiling, real-time signature recognition, and intuitive user feedback. Up to now, several works studied non-intrusive load monitoring techniques to classify appliances. However, the market shows a lack of practical adoption of such techniques due to practical issues when deploying the systems into existing buildings. In contrast, this paper focuses on devising a testing a comprehensive system to allow system plug-and play capability and empower users profiling, benchmarking and recognizing loads in real-time, which was holding back the deployment of such systems into practice.

The rest of the paper is organized as follows: Section II refers to existing appliance load monitoring techniques. In Section III, we describe the system challenges and motivate our design choice. In Section IV, we detail the design of the RECAP system including appliance profiling, recognition, the database of signatures and user interface. Section V presents the experimental results from a real deployment. Finally, Section VI discusses the system and future work before concluding the paper in Section VII.

II. RELATED WORK

Many approaches to appliance load monitoring have been investigated. Hart paved the way with the Nonintrusive Appliance Load Monitoring (NALM) [4]. NALM segments normalized power values, to characterize the power signal in successive steps or events, and match them to appliance signatures. The technique has achieved an average error of 6.3% for total household energy consumption. Remaining challenges to NALM, which are addressed by RECAP, were the ability to decompose a power signal made of overlapping on/off events on multiple appliances, and to recognize complex appliance patterns.

The load disaggregation algorithm [9] takes a very similar approach of comparing each change in the total power signal to each appliance operating range. In order to differentiate tricky cases where observed patterns may fit multiple appliances, a classification of appliances according to their frequency of use balances the decision making to the frequently used device.

With ViridiScope, Kim et Al. [15] use indirect sensing to evaluate the power consumption of home appliances. Ambient signals placed near appliances estimate power consumption by measuring sound and magnetic field variations when appliances are on or off. Even though sound sensors may be cheaper than a home energy monitor, one sensor and one transmitter per appliance are needed. Furthermore, more than the unaesthetic aspect, inaccessible or outdoor appliances as well as the addition of new appliances make the installation and correct operation of sound sensors difficult. In contrast,

RECAP aims at achieving appliance recognition by deploying a single energy monitor clipped around the live wire of the main electrical unit.

Patel et Al. [10] detect the electrical noise on residential power lines created by the abrupt switching of electrical devices and the noise created by certain devices while in operation. The approach relies on the fact that abruptly switched electrical loads produce broadband electrical noise either in the form of a transient or continuous noise. The deployment phase consists in collecting and recording noise signatures from appliances in the on, off and idle states. Aforementioned problems of variable power drawn by some appliances as well as concurrent on/off events affect similarly this approach.

Quantum Consulting Inc. developed an algorithm with rules based on pattern recognition. The input is the premise level load data, information about standard appliances and assumptions about the customer's behavior [7]. Forty houses were evaluated during four summer months. Disaggregated load profiles have differed by less than 10%. Unfortunately, this system requires at least one sensor per appliance deployed for several days for the setting of initial operating characteristics. This is not a cost-effective solution and makes the system hardly applicable in real scenarios.

Farinaccio et Al. [8] use a pattern recognition approach to disaggregate the total electricity consumption in a house into the major end-uses. However, this work does not address appliance profiling and assumes a constant appliance signature, which in reality varies with the house/room load and the way the appliance is set. Other techniques use wired solutions or employ smart sockets. This requires retrofitting the whole building, which is not cost-effective and may apply only to new structures. In contrast RECAP is based on a single wireless and low-cost low-power solution that integrates profiling of appliances, namely Unique Appliance Signatures (UAS), storing of signatures for further use, autonomous recognition through machine learning technique and a simple user interface.

Overall, although the literature shows some existing research activities on this domain, existing systems address requirements in a disconnected manner, target specific cases and fail to meet system usability requirements. Up to now there is a lack of a low-cost tool that addresses system usability to empower the user with a system that integrates appliance profiling, generation of unique signatures, relational signature storage, and a basic user interface for appliance activity recognition, which are the main focus of this contribution to extend the current literature.

III. CHALLENGES

The main challenges in recognizing appliance activity are mainly due to the following:

- **Appliances with similar current draw:** The system should be able to discriminate between two appliances with similar or same energy consumption;

- **Appliances with multiple settings:** Some appliances can be either tuned according to user needs or have different phases with different associated consumption, e.g. stand-by mode or washing cycles. The system should either understand the various appliance settings or recognize appliances based on additional data independent from the chosen setting;
- **Parallel appliances activity:** The system should disaggregate appliances activity identifying each constituent accounting for the total power consumption;
- **Environment noise:** The system should be resilient to external factors such as not-profiled appliances that can be turned on unexpectedly;
- **Load variation:** The energy provider can deploy devices at substation level for power factor correction, which can destabilize the matching with the appliance profile;
- **Long appliance cycles:** The system should be able to cope with appliance with long working cycle, which may result in long profiling periods.

In order to address these challenges, system adaptivity and resilience to dynamic and unpredictable environment are needed. To this end, the properties of existing machine learning techniques represent a suitable solution to reach the goal. In attempting identify an appropriate machine learning technique for recognizing appliances, we initially considered the following classifiers:

- **Markov Chain classifier:** Although Markov Chains (MC) are employed in many classification and pattern recognition algorithms a negative aspect is that simple Markov Chains can merely handle one state at time. This means that the number of states could grow greatly if we map each state with a possible combination of appliances active at the same time. Although MC can be a suitable solution for monitoring a limited number of appliances, the system may not scale well to handle appliances in the order of tens via a single energy meter, which is a major objective of RECAP. Multistate Markov chains are a possible solution to address this issue but they may greatly increase the complexity of the system when a large number of appliances is profiled. Another limitation of this solution is its flexibility. If the user wants to add a new appliance, the Markov chain requires a number of parameters to be set, which can obstruct system usability in light of the fact that the system may be used by non-IT experts. In view of such drawbacks, we opted for the investigation of a more scalable classifier.
- **Bayesian classifier:** A main advantage of this solution is the simplicity of the algorithm. Despite its apparent minimalism, Bayesian classifiers can give appropriate results with only limited data. A limitation of this type of classifiers is the resistance to parameter variations such as power variation and duration. Since parameter variations are a key elements due to power factor correction by the energy providers and signature aging control existing circuit breakers This factor is key for the scope of appliance

recognition

In contrast to previous techniques, **Artificial Neural Network** (ANN) to perform appliance recognition are manifold including: (1) the ability to handle any type of data (2) the unnecessary prior understanding of appliance behaviour; (3) the easy extensibility to higher number of inputs, many types of values or dissimilar kind of data; (4) the learning process that can be automated for example through additional profiling sensors that can turn on/off appliances remotely; (5) the ability to learn while running through mechanisms of error feedback from the user; (6) the ability to handle multiple simultaneous appliance states. In contrast, a drawback of the ANN solution is the lengthy training process that may take few minutes, e.g. in the presence of more than 15 appliances to profile or if some appliances have long signatures e.g. a washing machine with a multi-state signature.

IV. SYSTEM DESIGN

A. Data Acquisition System

Recent standardization efforts have generated an increasing trend towards the integration of sensor systems in building automation systems, allowing the connection of low-cost sensing and monitoring units and the gathering of energy consumption information in real-time.

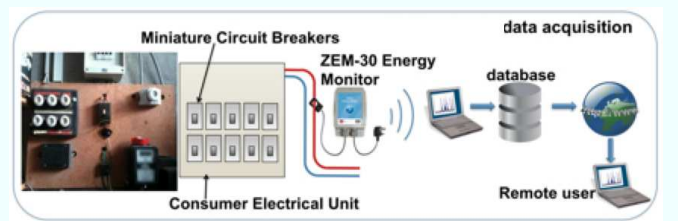

Fig. 2. Energy Monitoring Data Acquisition System

Although the RECAP system is independent from the communication protocol used by the energy monitor, the unit used for testing transfers data via a ZigBee-based acquisition system to a gateway connected to a local machine, which connects to either a local or remote relational database for storage, as shown in Figure 2. The RECAP system resides on the local machine and processes energy data as they arrive from the network. In particular RECAP is able to firstly generate appliance signatures and then train an ANN to recognize appliance activities on the spot. This starts with the appliance profiling phase, a one-off procedure that allows RECAP to characterize appliances that the user wants to recognise. The profiling will create a set of *unique appliance signatures* that will then be used for the real-time activity recognition. To keep record of appliance activity times, once an appliance is turned on/off, the system records this into a dedicated table in a remote database.

B. Appliance Profiling

A crucial aspect to consider is what parameters will contribute to the generation of a given signature. For example the real power consumption can discriminate between appliances with dissimilar power consumption but may fail when appliance consumption is similar.

In order to identify the important constituents for a unique appliance signature, we now highlight the main electrical parameters for an appliance working on alternate current (AC). According to its internal circuit, an appliance can be of resistive, inductive, or capacitive, predominance. For example a kettle is almost purely resistive while a fan can be predominantly inductive. Inductors and capacitors affect the power consumption by shifting the alternate current with respect to the alternate voltage. In particular, capacitors delay the current with respect to the voltage while the opposite happens for inductors. Considering that the power is the multiplication of voltage and current, if voltage and current are shifted, the power transferred to the appliance is less. This effect is captured by the active and reactive power components, which, in mathematical terms, correspond to real and imaginary part respectively, as shown in Figure 3. In general, appliances work through the real power (active), while the reactive power (passive) is due to the presence of storage elements in the appliance circuit (inductors or capacitors), does not work at the load and heats wires. Pure resistive appliances show no shift of current and voltage, the reactive part is null and all the power is transferred to the load. In contrast, the larger the current/voltage shift the greater the imaginary component. Reactive and active powers are key parameters to calculate the power factor, which is captured by the energy meter. Equation 1 reports the relation between the active, reactive and power factor.

$$S = P + jQ \quad Pf = P/|S| \quad (1)$$

where S = Apparent/Complex power, Q = Reactive Power, P = Active Power, Pf = Power Factor, and $|S|$ = real part of the apparent power.

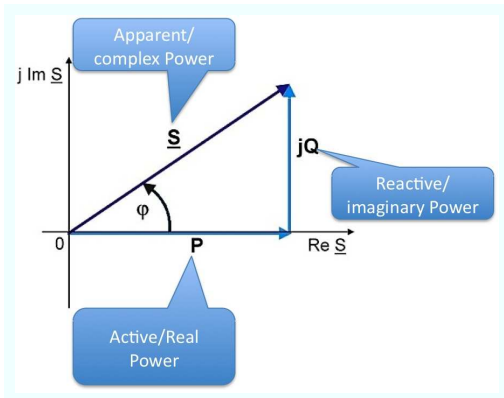

Fig. 3. Relation between reactive and active power

C. Unique Appliance Signature

Based on the relations between the power components and how they map to appliance types, this section introduces the constituents of a unique appliance signature. The **real power** is the first important constituent that can discriminate appliances of dissimilar consumption. To address appliance with similar consumption, the **power factor** can discriminate between appliances of resistive, capacitive and inductive types. Following, the **peak current** relates to the appliance circuit specifics, as it represents the maximum amount of energy the appliance allows before reacting. RECAP collects also **RMS current** that provides consumption information independently from the voltage given by the energy provider. Finally, **peak voltage** and **RMS voltage** relate to the specific voltage provided when the signature is made. Overall, the system identifies 6 constituents to generate a unique appliance signature, which is the base to discriminate between multiple appliances activity. Additional factors captured when profiling appliances are the **signature length** and the meter **sampling frequency**. These parameters are key to translate signatures from dissimilar types of energy meters into a standard signature. In fact, when profiling appliances, users may generate signatures of dissimilar duration in order to capture diverse appliance power modes. For example, an electric oven presents an initial period of almost constant current draw followed by periodic deactivations when the set temperature is reached a shown in Figure 4. Finally, to avoid inconsistencies between signatures generated with meters at dissimilar sampling frequencies, RECAP implements a simple function that translates signatures into a standard frequency before storing it in the relational database. Figure 4 shows power signatures for 4 appliances of different lengths and standard sampling frequency of *1 value per minute*.

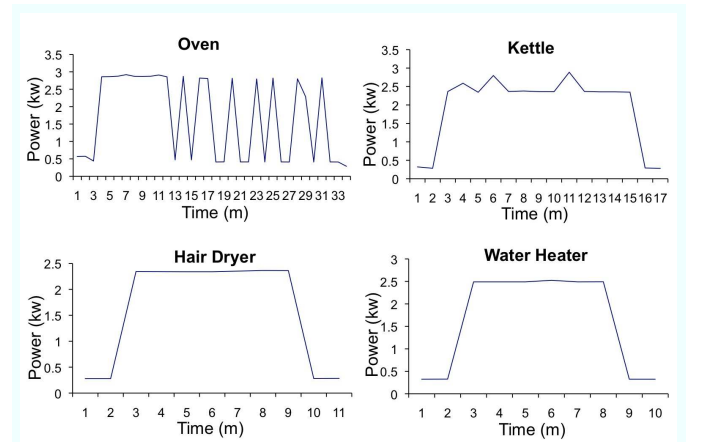

Fig. 4. Active Power Signatures for 4 appliances

D. Signature Database

Once a new appliance is profiled, the signature together with some metadata relative to the appliance model and location are stored locally and duplicated in a remote database.

The duplication allows the creation of a common repository of signatures used to train the ANN and share signatures with other users, namely *Unique Signature State Information (USSI)* database. In fact, providing a common signature repository for multiple homes can progressively reduce the initial training phase required by RECAP. Figure 5 shows the USSI database associated to RECAP. USSI consists of 6 main relational tables. 3 main tables, namely *Captured Parameters*, *Physical* and *Environmental* relate directly to the signature. Since certain types of appliance type with either dissimilar models or from various manufacturers are likely to have dissimilar signatures, the table "*Physical*" captures the specifics of the appliance.

As the USSI database grows, it is necessary to provide techniques to present to the user an initial standard set of relevant signatures. Through the *Environmental* table the system can provide a common list of appliance signatures based on user location (password protected). It is in fact common to have same appliance models concentrated within the same area or region (e.g. electric showers are very common in Ireland and UK while a certain HVAC model are more common in warmer countries). By using the RECAP interface, the user can then browse the list of appliance models in the area or search for other signatures should the appliance be not in the list. Currently, the USSI system in RECAP is implemented in an SQL-based relational database.

Furthermore, the *Environmental* table provides information of surrounding conditions during measurements as this may affect the signature accuracy. USSI was designed with a broad use in mind such as a large number of signatures generated by contributors. To address multiple contributors for the same signature, the database implements a *Contributor* table that includes a confidence rate, which increases according to the reputation of the contributor. We envision that a reputation would increase based on collection of opinions from other users. The USSI system can handle multiple signatures of the same appliance ID according to the *Signature Property* table. Similar to contributor reputation, the *Energy Meter* table stores the accuracy of the energy meter, which can be used to tune the appliance recognition algorithm. For example, in RECAP this would enable testing the meter accuracy and associate accuracy levels to different activation functions.

E. Training and Recognition

Following the profiling phase, the generated signatures are used to train an ANN for the recognition of appliances. The basic element of an ANN is a neuron, which can be represented as a simple succession of mathematical operations, such as weight balancing, sum and an activation function as shown in Figure 6.

Each input of a neuron is balanced by a different weight and is then aggregated into an activation function that can be as simple as a step function, or a more complex function such as hyperbolic tangent. An ANN consists of several neurons interconnected. Figure 7 shows a common type of ANN, 3-layer ANN, which is in fact the type adopted for RECAP, as

Captured Parameters	Environmental
Signature ID (SID)	SID
Real Power	Device Location
Power Factor	Temperature
RMS Current	Humidity
RMS Voltage	Contributor
Peak Current	User ID (UID)
Peak Voltage	Name
Sampling Rate	Confidence Rate
Timestamp	Association
State: [startup, steady, shutdown, off]	Energy Meter
Physical	Meter ID (MID)
Appliance ID (AID)	Device Type
Type	Accuracy
Model	Signature Property
Make	SID (Primary key)
Power Rating	AID
Voltage Rating	MID
Frequency Rating	UID

Fig. 5. Integration of unique signature state information

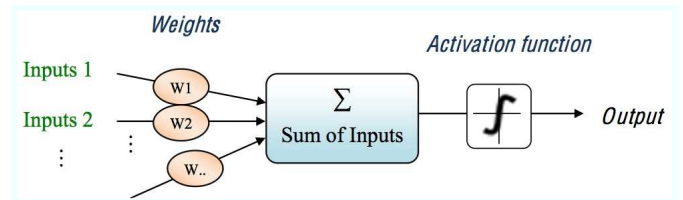

Fig. 6. Single neuron showing input weights, weighted sum and activation function

provides a judicious balance between complexity and response time. The first layer consists of Inputs Neurons i.e., neurons with one or more inputs connected to external or internal data. The second layer consists of Hidden Neurons that have inputs connected to the outputs of the first layer and are not in direct relation with inputs and outputs of the ANN. The Third layer consists of Output Neurons that have inputs connected to the outputs of the hidden neurons. Output neurons represent the direct outputs of the ANN. The connections between the layers and neurons can vary. For example, the input layer can be connected to the output of the ANN in order to provide a feedback informing the new input state about the previous output. RECAP uses a similar feedback mechanism to improve

the accuracy by allowing the user to notify the system of an incorrect guess.

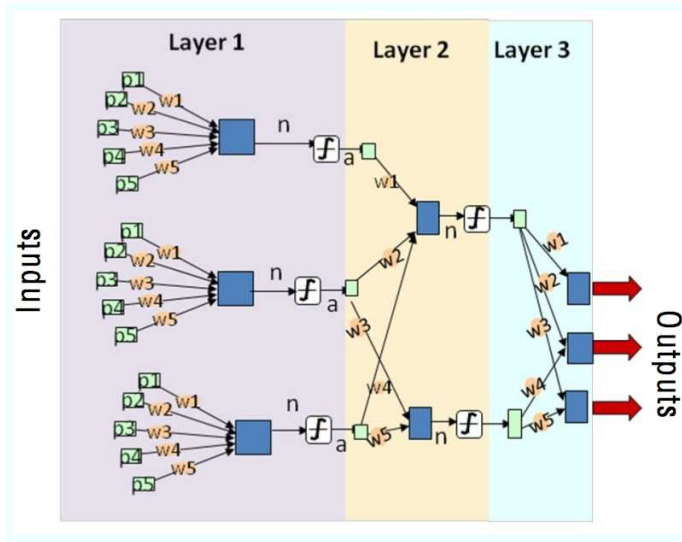

Fig. 7. An example of 3-layer ANN showing input, hidden and output neurons

We now describe the ANN learning process. At the beginning of the learning phase, all weights are random. Weight coefficients of neurons are modified using the data from a training data set, based on combination of appliance signatures. The data and corresponding weight modification propagated through the hidden layer and then the output layer. During training phase, the output signal generated by the ANN is then compared against the desired value, namely the target, as given in the training data set. The difference between the target and the output layer of the network is called error δ . This error is then back propagated to the hidden neurons and the input neurons and the weight of each neuron may be modified accordingly. Equation 2 provides the calculation used to tune the weights.

$$W_n = W_o - (\delta * Lr) \quad (2)$$

where W_n is the new Weight, W_o is the old weight and Lr is the learning rate sets to a constant value to avoid inconsistencies due to rapid weight changes.

The back propagation ends when all the layer weights are adjusted and the ANN is ready for another "wave" of data. Naturally, the more sophisticated the training data set, the finer the weights will be tuned to recognize any combination of appliance activation. To improve system usability, RECAP implements an **automatic training program (ALP)** that allows autonomous training of the system. ALP uses the generated signatures and creates a training data set with all possible combinations of appliance activity, which is then used to tune the neuron weights autonomously.

It is important to determine the correct number of neurons and the configuration of the network. In general a large number of hidden neurons may result in long training times and a

system that may perform extremely well on the training data set but cannot handle unseen data. In contrast, an inadequate number of neurons cause the inability to handle complex combination of appliances and poor results. Although the literature offers several programs to find the optimal number of neurons, we opted for tuning the ANN empirically. A number of trials allowed the identification a saturation point after which the network showed little further improvement. The current version of RECAP adopts 6 input neurons matched with 6 hidden neurons, which performed adequately for the 6 input parameters used to generate the signatures.

Finally, an important aspect of the ANN is the **Activation Function**, which shapes the output of the neurons. Considering that the output of the network should correspond to one of the profiled appliances, after several empirical trials we adopted a general *sigmoid function*, which is close to a threshold function with smooth angles to allow some neuron uncertainty in case of errors within the order of 5% or more e.g., to account for small variation of power delivered by the energy provider.

F. Graphical User Interface

In order to facilitate user interaction, RECAP provides a basic user interface, which integrates the profiling of appliances, the network training and the final displaying of appliance activity. These functionalities are divided in 4 separate panels as follows:

- **Add An Appliance:** As shown in Figure 8, this panel allows the user entering a JPEG image, name/model and type of appliance to profile. The panel provides also a predetermined list of appliance types already available in the database for the convenience of the user. Once the information is entered, the user can press on "save and go to next step", which is the appliance profiling phase.

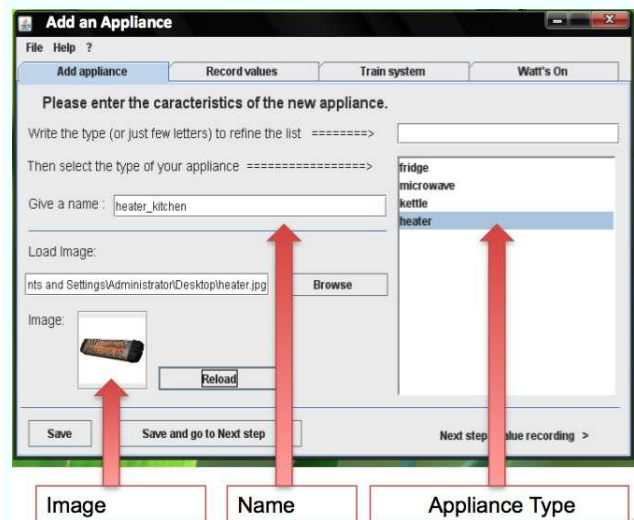

Fig. 8. The "Add Appliance" panel used for inserting the appliances to be profiled

- **Generate A Signature:** This panel, shown in Figure 9, is used to record appliances profile in order to generate

signatures. The panel is provided with a list of added appliances; by clicking on the button "Start Recording", the user will be prompted with "please, turn on the appliance to be profiled". The system will automatically recognize the delta variation relative to the appliance being turned on and will start recording the parameters. For the duration of the profiling period, the button will stay red and display "recording in progress". During this period, the system requires that no other appliances be turned on or off. The button will turn green after receiving a sufficient number of values per each energy parameter. Based on some initial experiments, the minimum number of values to build an accurate signature has been set to 4, which correspond to 4 packets from the energy meter. Obviously, the time needed to generate a signature depends on the meter transmission rate. In our experiments, the meter was transmitting at a rate of 1 packet/min as preset by the manufacturer. Should system detect some anomalies during this recording period, the appliance profiling is aborted and the user may restart the process.

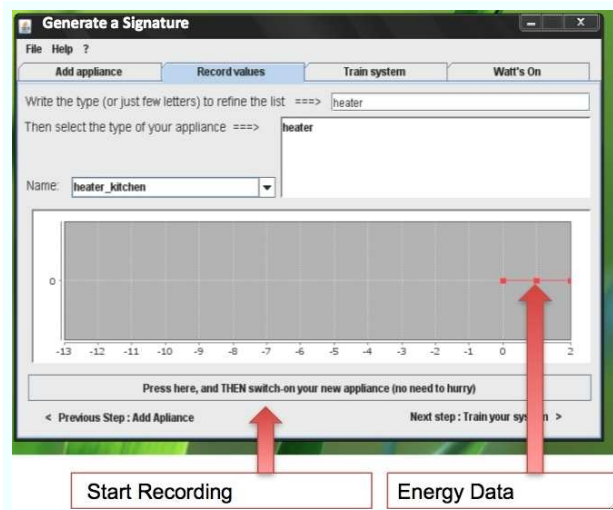

Fig. 9. The "Record Values" panel used for generating appliance signatures

- Training:** This panel, as shown in Figure 10, consists of a list of profiled appliances, on the left hand side of the figure, which will be used to train the network. In case of some unutilized appliances in the list, their removal from the training list is done through the *Remove* button on the right-hand side of the panel. The training of the ANN is performed by pressing the "Start learning" button, while the expected recognition performance and training progress bar are on the lower part of the panel. Overlapping appliance activities during profiling may cause jagged signatures and poor performing training periods. In case the recognition performance does not meet the requirements dictated by the application, the user can go back to the "Record Values" panel and re-record the uncertain signatures. We also identified that longer

and steady signatures increase the system confidence and provide a better performance forecast.

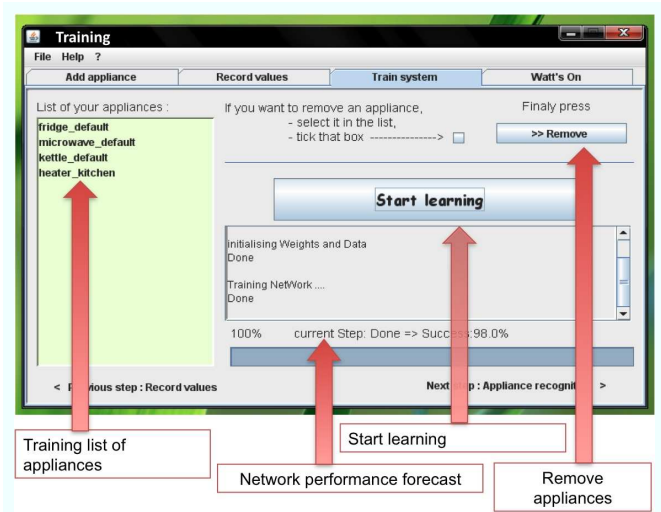

Fig. 10. The "Train system" panel used for training the ANN with profiled appliances

- Recognition:** As shown in Picture 11, this panel displays the real-time activity of appliances. Active appliances are displayed in colour while inactive appliances are displayed in black and white. At the bottom of the panel, a statistics window allows following the historical data relative to appliance activity and energy cost associated to each appliance.

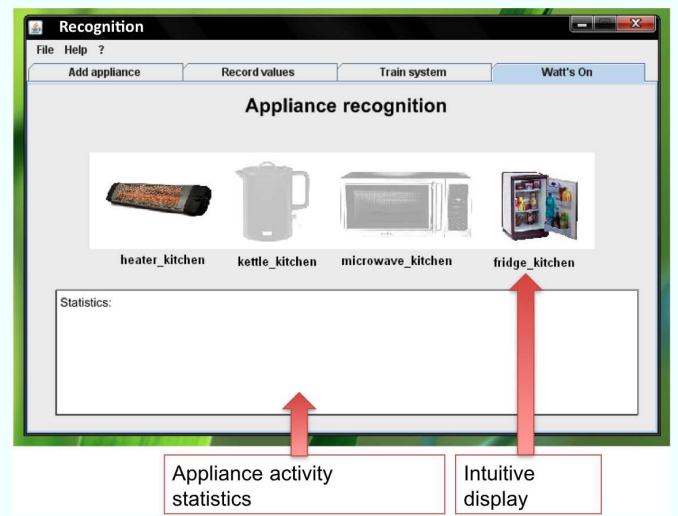

Fig. 11. The "Watt's On" panel used for displaying appliances activity and statistics

V. EXPERIMENTATIONS

The experimentations of the RECAP system have been conducted in the kitchen area of the CLARITY centre at University College Dublin. We connected the energy monitor to the

miniature circuit breaker in the electrical unit, which controls the whole kitchen area and the corridor including sockets and lights. For the experiments, we used the off-the shelf ZEM-30 ZigBee-based Energy Monitor from Episensor [3], as shown in Figure 12. This energy monitor is equipped with a current transformer (CT) clipped around the live wire of the consumer electrical unit.



Fig. 12. Episensor ZEM-30 ZigBee Energy Monitor

The first objective of the experiment was to recognize 3 main appliances present in the kitchen area: a kettle, a microwave and a fridge. Initially, 3 appliances were profiled and signatures produced for them. We tested the system for one week and instructed people using appliances and sockets in the area to annotate time of usage. During the week, the annotation reported that the 3 main appliances were activated several times per day together with other lower consuming devices, such as lights and a small fan. Occasionally people used the sockets to plug in their laptops and phone rechargers. This initial trial showed accuracy over 95% due to a much higher power consumption of the 3 appliances than the lights and other low consuming appliances.

Given this initial encouraging performance, we decided to test the system in a more demanding scenario in which a user profiles an appliance that shows both similar power consumption and power factor characteristics as other existing signatures. We identified an electric fire as a resistive appliance with similar consumption of microwave and kettle. The electric fire was introduced in the kitchen and its signature generated. The objective of this experiment was to test whether RECAP could still distinguish appliances based on the remaining signature parameters. Figure 13a shows the real appliance activity, which was manually annotated and used for comparison against the output from RECAP. Figure 13b shows the raw output from the ANN in response to the input energy data. An appliance is considered active if the output from ANN is equal or greater than 1. The output coming from the system is then passed through a filter module, as shown in Figure 13c, which converts the raw output into actual appliance activity, display the results on the user interface and annotate the activity into a dedicated table in the database. We collected information over 65 minutes while many low consuming un-profiled ap-

pliances were also activated occasionally. In contrast, we never activated the electric fire for the entire duration of the experiment to simulate the worst-case scenario of having an unknown high consuming appliance. By doing this, the system could not reinforce its neurons by comparing the heater against other appliances activity and learn the difference. In spite of this adverse condition, the experiment demonstrated how the system guessed correctly 55 times over a total of 65, which corresponded to an accuracy greater than 84%.

In order to test system scalability, we performed tests regarding the time needed to train the ANN with a various number of appliance signatures. Average training time showed a large dependence on the machine used and the length of signatures. However, we can report with confidence that, for a regular pentium 4 machine, the training remained below 1 minute for up to 15 appliances while showing a much larger increase when more signatures were introduced. Based on this, a limit of RECAP is the inadequacy to recognize a great number of appliances in a building. Instead, it should be trained to recognise a subset of appliances activity at a time in the order of 15 or less. Finally, the presented evaluation demonstrated how RECAP can guess with high level of accuracy appliances that have an almost constant level of energy consumption, while further tests are needed to understand the performance for appliances with dissimilar power and changing power consumption due to power cycles.

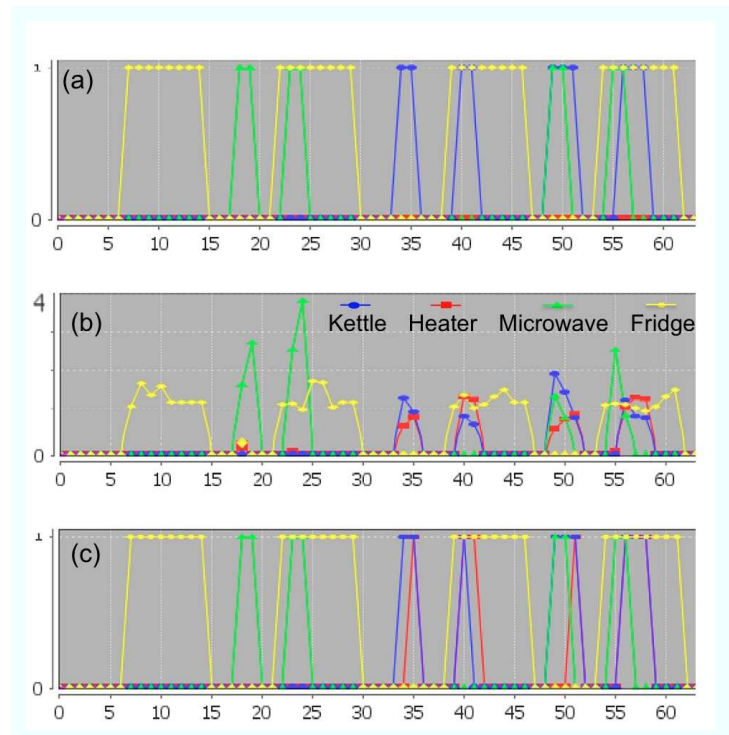

Fig. 13. Tests performed in the kitchen area at the CLARITY centre. (a) real appliance activity (b) ANN raw output; (c) output filter.

VI. DISCUSSION AND FUTURE WORK

We foresee 3 major user cases for this platform: (1) creating real-time energy awareness for home owners to pinpoint appliance consumption useful to understand the reasons of expenditures to curb energy cost; (2) Enabling load shifting, by autonomously understanding activity, to alter the pattern of energy usage so that on-peak energy use is shifted to off-peak periods; (3) Providing a personalised energy bill including personalised hints as to how to reduce cost by using energy in non peak hours. By informing end users, e.g. that their local substation is subjected to repetitive energy peaks, the electricity provider can also give adjunct services such as advice of how to implement electricity usage shifting techniques for certain appliances. The advantage for the energy provider is that it can employ peak leveling techniques aiming at a more efficient energy distribution by temporary deactivation of some power stations.

The results presented in this paper are encouraging as obtained in real conditions. However, we acknowledge that further experimentation is needed to test the system for more complex appliances, such as appliances with different power cycles that periodically go into stand-by, e.g. iron and electric oven, when the temperature reaches a certain threshold. Following the experimentations presented in this paper, currently the RECAP system is undertaking major tests in 20 homes, each of them provided with a ZigBee based smart meter around the area of Dublin City. This large scale test aims at providing substantial scalability tests for a large range of appliances and scenarios. The RECAP system can be downloaded from the CLARITY centre Wiki page [13].

Future work will include a more extensive performance evaluation and user feedback in regards to the appliance profiling and user interface. Future work will address the full automation of signature creation and energy data annotation. Although the RECAP user interface guides the user through this process, the system still requires human supervision for profiling and calibrating appliance load monitoring systems, which delays performance testing in large-scale. A major future work will also include the creation of a Wikipedia for appliance signatures connected to an open database. Appliance recognition is a powerful tool and affords possible inputs into varied application domains such as Ambient Assisted Living (AAL) where activity patterns could be determined through appliance usage.

VII. CONCLUSIONS

This paper presents a detailed description and results of an intelligent system for Recognition of Electrical Appliance activities in Real-time, namely RECAP. The objective was to provide a plug-and-play tool to create energy awareness by identifying consumption of individual appliances. This represents a basis for related load shifting techniques aimed at reducing energy expenditure in buildings. The system integrates (1) appliance profiling to generate unique appliances signatures; (2) a database for storing appliance signatures; (3) a neural network-based technique to recognise the appliances

profiled; (4) a simple graphical interface to guide the user profiling appliances and displaying their disaggregated consumption.

RECAP was tested in a prototypical real kitchen scenario and showed accuracy greater than 84% for all the cases studied. The system is based on recent advances on energy monitoring through ZigBee-based low-power wireless communication. RECAP is amenable to quick installation within an existing building and it is suitable to general off-the shelf energy meters. The system uses a single electrical energy sensor clipped around the live wire of the main electrical unit. RECAP is a versatile system with potential applications that include: decomposing the electricity bill, recognising energy hungry devices and electricity leaks, and identifying possible improvements in terms of energy saving. Ancillary applications include recognition of occupant behaviour for ambient-assisted living. The RECAP system is available to download from the Wikipedia of the CLARITY centre [13].

VIII. ACKNOWLEDGMENTS

This work is supported by Science Foundation Ireland under grant 07/CE/I1147 and through the SFI-funded National Access Programme (NAP).

REFERENCES

- [1] EIA. Energy information administration. *Use of Energy in the United States Explained*, 2009.
- [2] EIA. Energy information administration. In *Annual Energy Outlook 2009 with Projections to 2030*, 2009.
- [3] Episensor. Zem30 energy monitor. <http://www.episensor.com>, 2009.
- [4] G. Hart. Nonintrusive appliance load monitoring. *Proceedings of the IEEE*, 80(12):1870–1891, Dec 1992.
- [5] IETF. Internet engineering task force, ipv6 for low-power pan. <http://www.ietf.org/html.charters/6lowpan-charter.html/>, 2004.
- [6] IETF. *Internet Engineering Task Force, Routing over low-power and lossy networks (ROLL)*, 2004.
- [7] B. S. J. Powers, B. Margossian. Using a rule-based algorithm to disaggregate end-use load profiles from premise-level data. In *Transactions of the IEEE Computer Applications in Power*, 1991.
- [8] R. Z. L. Farinaccio. Using a pattern recognition approach to disaggregate the total electricity consumption in a house into the major end-uses. In *Energy and Buildings*, 1999.
- [9] M. L. Marceau and R. Zmeureanu. Nonintrusive load disaggregation computer program to estimate the energy consumption of major end uses in residential buildings. In *Energy Conversion and Management*, volume 41, pages 1389 – 1403, 2000.
- [10] S. Patel, T. Robertson, J. Kientz, M. Reynolds, and G. Abowd. At the flick of a switch: Detecting and classifying unique electrical events on the residential power line. In *UbiComp 2007: Ubiquitous Computing, LNCS 4717, Springer*, pages 271–288, 2007.
- [11] P. Petroni, M. Cotti, and O. Bono. The new edge for the enel telegestore: An integrated solution for the remote management of electricity and gas distribution allowing a total management of the energy consumptions. In *Electricity Distribution, 2009 20th International Conference and Exhibition on*, pages 1–5, June 2009.
- [12] PG&E. Smartmeter gas and electric meters installation. <http://www.pge.com/smartmeter/>.
- [13] RECAP. Recognition of appliance and profiling in real-time. http://www.clarity-centre.org/claritywiki/index.php/REAR_Tutorial.
- [14] Ted. The energy detective. <http://www.theenergydetective.com/index.html>.
- [15] Z. C. Younghun Kim, Thomas Schmid and M. B. Srivastava. Viridiscope: design and implementation of a fine grained power monitoring system for homes. In *UbiComp*, pages 245–254, 2009.
- [16] Zigbee. Zigbee alliance working group web page for rf-lite. <http://www.zigbee.org/>, 2002.