

Recent Advances in Active Noise Control Inside Automobile Cabins

Prasanga N. Samarasinghe*, *Member, IEEE*, Wen Zhang, *Member, IEEE*
and Thushara D. Abhayapala, *Senior Member, IEEE*,

I. INTRODUCTION

Minimization of interior cabin noise has been a key topic of research in the automobile industry for the last two decades. This problem was initially approached via passive noise cancellation methods, where physical treatments such as structural damping and acoustic absorption were used. However, with vehicle manufacturers striving for more economical and light weight designs, the resulting car interiors invariably became noisier due to the increased structural vibrations. These noise fields are generally dominated by low frequencies (i.e, 0 – 500 Hz) [1], [2], hence the conventional passive noise cancellation approaches are less effective. In an attempt to resolve the above problem, Active Noise Control (ANC) methods were developed where secondary sources were proposed to attenuate the noise inside the cabin. With modern in-car entertainment systems providing 4 – 6 built-in loudspeakers, the addition of an Active Noise Control system comes at a relatively low additional cost.

In practice, in-car ANC is achieved by producing a secondary signal(s) that cancels the noise generated by the noise source(s). The residual difference between these two components is measured using a microphone(s) placed inside the cabin, and is minimized using a feed-forward/feed-back control system [3]. Feed-forward systems use a time-advanced “reference signal(s)” correlated with the noise signal to attenuate the primary noise field, whereas feed-back systems tend to attenuate the overall measured noise. The basic concept behind ANC inside vehicles is described in Fig. 1, which shows how a secondary soundfield cancels out the undesired noise field utilizing an adaptive controller. Since the noise observed inside vehicle cabins is often random and time varying, the aforementioned control systems are required to be adaptive. While the theory and concept behind ANC systems are quite straightforward, their practical implementation and performance are often hindered by factors such as the noise field complexity inside the car geometry, cost, adaptive system convergence time, system stability, non-causality and poor spatial coverage. Over the last 30 years researchers and car manufacturers have done extensive amounts of experimental research to overcome these limitations [1], [4]–[6].

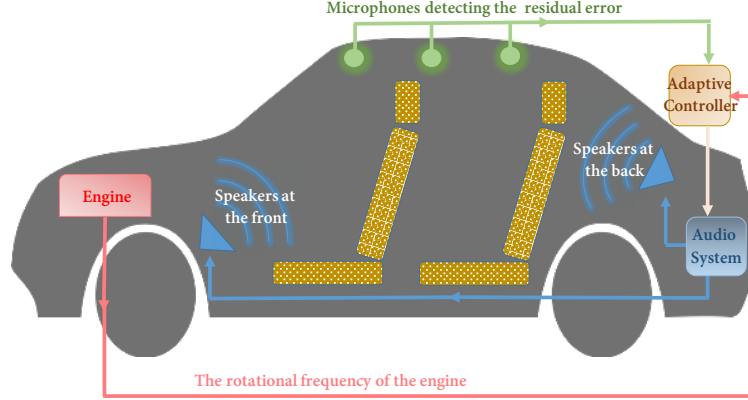

Fig. 1. Active Noise Control inside an automobile cabin

In this article, we review ANC techniques for noise cancellation inside automobiles. We explain the different types of noise fields present inside vehicles, the theoretical basics of ANC techniques and their applicability in canceling the aforementioned noise fields. We focus on recent advances made in vehicle ANC during the past 10 – 15 years including commercial developments available in mass production vehicles. We aim to show that in-car ANC is an exciting field of research with the potential to substantially improve the passenger experience in acoustically challenging environments.

II. NOISE SOURCE AND NOISE FIELD INSIDE VEHICLES

Different kinds of noise sources exist in automobiles, such as engine noise, road-tyre noise, and wind noise, with their own distinct acoustic properties. The vehicle compartment can be considered a very small room and depending on the frequency, the acoustics inside the car exhibit completely different physical behaviors. This section reviews the attributes of typical noise sources, and noise models, which effectively describe the noise fields inside automobiles.

A. Attributes of Noise Sources

1) *Engine Noise*: Most road vehicles with four or more wheels employ a reciprocating, four stroke, internal combustion engine [7]. The noise produced by the internal combustion engine is dominated by two processes, the piston crank mechanism and the combustion process. The piston crank mechanism, such as the movement of pistons and their lines, generate an impulsive noise with a flat spectrum; the combustion process on the other hand produces a tonal noise, which is directly related to the rotational speed of the engine. ANC strategies are generally more effective in controlling combustion noise processes due to its predictive nature. Based on in-car noise measurements, there exist two simple relationships

between the engine type and the resulting combustion noise. Given the engine size expressed in terms of the number of cylinders and their individual capacity in liters, the average noise level can be empirically estimated using the following equation [6]

$$\text{Noise Power Level} = 10 \log_{10}(\text{no. of cylinders}) + 23 \log_{10}(\text{cylinder capacity}).$$

With the knowledge of the engine rotation speed, the fundamental noise frequency/firing frequency/dominant engine order is

$$f_0 = \frac{\text{rotation speed}}{2 \times 60} \times \text{no. of cylinders}.$$

Derivation of the dominant engine order at any given rotation speed (rpm) is straightforward. First, the rpm is converted to Hertz by a multiplication of 1/60 (e.g., an engine spinning at 1800 rpm can be said to be running at 30 Hz). Second, since a four-stroke engine fires each cylinder only once every two crank revolutions, the rotations per second is multiplied by half the number of cylinders (e.g., for a 6 cylinder engine spinning at 1800 rpm, the dominant engine order is at 90 Hz), which gives the fundamental frequency. In a six-cylinder engine, it's also called the "third engine order" because the frequency is three times that of the engine's rotation in Hz. While the dominant engine order defines the engine's distinctive sound character, its overall timbre is decided by multiple variables such as its structure, plumbing and materials, which cause additional engine orders to become active. Therefore, typical engine induced noise carries multiple engine orders.

In automatic transmission powertrains, the torque converter and torque converter clutch are critical devices governing the overall power transfer efficiency. They create a one to one connection between the output of the engine and the input of the transmission. With increasing demand for fuel economy, the recent trend is to apply the torque converter clutch over a wider range of driving conditions. This increases powertrain high torque fluctuation and causes noise and vibration. While there exist many passive control solutions for this issue, active control of noise and vibration is one of the most efficient solutions because active control avoids the addition of extra weight [8].

2) *Road-tyre Noise*: Road-tyre noise is produced due to the interaction between the road surface and the tyre, which can be classified mainly into two kinds, air pumping noise and vibration induced noise (or road booming noise) [7]. Air pumping noise is caused by the tyre/tread pumping when on a rough road surface. Normally, this kind of noise is dominated by high frequencies and its level is dependent on factors such as the size of the road, the size of tyre cavities, the load on the tyre, and the pressure inside the tyre. In contrast, vibration induced noise (or road booming noise), is mainly due to the non-uniformity of road surfaces, change of vehicle speed and irregularities in the tyre tread pattern. There are several characteristics of vibration induced noise. First, it is generated by a combination of independent

vibrations of the four wheels, therefore it is hardly reduced by ANC techniques with one or two reference sensors. Second, the spectrum and properties of vibration induced noise vary continuously with varying road profiles and vehicle speed. Third, transfer function between wheel vibrations and road booming noise is non-linear. The above characteristics are often unique to the vehicle of interest and therefore, ANC of road noise is rather difficult to achieve in realistic conditions as opposed to laboratory set-ups.

3) *Wind Noise*: The wind noise is the predominant component of interior noise at speeds above 100 km/h [2]. It can be classified by the noise production mechanisms, such as (i) a low frequency broadband noise due to the vehicle moving through air at mid to high speeds or turbulent air flow through holes (e.g., vehicle windows and doors), (ii) an impulsive noise above 300 Hz due to the external varying wind conditions, and (iii) a narrowband beating noise due to air flow over open windows or sunroofs. The acoustic energy inside vehicle cabins due to wind noise is generally concentrated at the frequency band 50 – 500 Hz.

B. Noise Fields inside Vehicles

The vehicle compartment is generally considered as a small room and has distinct acoustic properties. Similar to room modes¹ At low frequencies, the sound field is dominated by a limited amount of acoustic modes. At high frequencies, as the number of acoustic modes increases, the sound field becomes increasingly diffuse, making it more accurate to be modeled using statistical methods. In this region, a typical phenomenon is the *spectral coloration*, where the spectral peaks and dips do not correspond to eigen frequencies of acoustic modes but are the result of numerous overlapping resonances. Often the Schroeder cut-off frequency [9] is used to separate the low- and high-frequency regions. This is about 300 Hz in a typical car compartment [6].

In current automotive ANC systems that are commercially available, the main objective is to globally cancel the dominant engine order(s) inside the vehicle cabin such that all passenger seats are covered. Global cancellation of noise requires the entire noise field inside the car to be considered. This is best done by describing the noise field in terms of acoustic modes, which depend on the noise field's frequency content, and the structural-acoustic coupling² of the enclosure. ANC control systems thus require the speakers positioned to control the above acoustic modes and the error microphones positioned to observe

¹Room modes or acoustic modes are a collection of resonances that exist in a room when the room is excited by an acoustic source. Most rooms have their fundamental resonances in the 20 Hz to 200 Hz region, each frequency being related to one or more of the room's dimension's or a divisor thereof.

²When a vibrating structure is in contact with air, some of the energy from the structure escape to the air as sound. This interaction referred to as structural-acoustic coupling.

the relevant acoustic modes. The effective frequency range of a given ANC system is determined by the modal density (the average number of modes in a unit frequency interval) of the automobile enclosure and the available number and placement of microphones and loudspeakers. This limitation is purely physical and does not depend on the control algorithm or software used for achieving ANC.

In the automotive industry, low frequency noise fields inside vehicles are often simulated using Computer Aided Technology (CAE) to assist production. CAE often uses the finite element method [10] and boundary element method [11] to model the vibrations and structural-acoustic coupling inside vehicle cabins. Since CAE is largely useful for ANC, and the current direction of commercial vehicle development is towards shortening the development time while decreasing the prototype vehicle quantity, there is an urgent need to improve the computer based prediction technologies at the planning stage [12].

III. ACTIVE NOISE CONTROL TECHNIQUES

Active noise control involves a system that cancels the primary (unwanted) noise based on the principle of superposition. In the time domain, for a single channel (SISO) system,

$$e(n) = d(n) + y'(n) \quad (1)$$

where $e(n)$ represents the error signal and $d(n)$ and $y'(n)$ represent the noise and secondary soundfields present at the error sensor respectively. Typical ANC systems require one or more loudspeakers to produce the secondary sound field, one or more microphones to measure the residual error signal(s) present at the observation point(s) of interest, and an adaptive control system to drive the loudspeaker(s) while minimizing the residual error. In-car ANC systems can be broadly classified as, feed-forward systems and feed-back systems depending on whether reference sensors are present, or broadband and narrowband depending on the operating bandwidth. The next two sections will review each system in detail, while providing their recent applications, mainly related to engine noise cancellation and road noise cancellation.

IV. FEED-FORWARD CONTROL SYSTEMS

Feed-forward systems use an additional sensor(s) (acoustic/mechanical/optical/electric) to measure the primary noise field or to generate a signal related to the noise generation mechanism. This reference signal(s) is processed by the ANC system to drive the loudspeaker(s), in order to minimize the residual error. The performance of feed-forward ANC systems is dependent on the coherence between the reference signal and the primary noise, thus there exists an inherent requirement for the reference sensors to be placed close to the noise source. The performance of a feed-forward ANC system also relies on the frequency spectrum of the primary noise. If the primary noise field is a random broadband soundfield, it

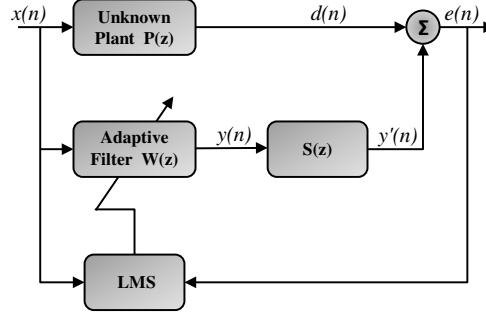

Fig. 2. Block diagram of a Feed-forward ANC system

is important that the reference signal and the adaptive system continuously track it. Furthermore, if the adaptive system's electrical delay (due to the processing time) is larger than the acoustic delay from the reference microphone to the canceling loudspeaker, the controller response becomes non-causal and the system performance will be substantially degraded. However, in narrowband feed-forward systems, the continuous tracking requirement and the causality condition are largely preserved because the reference signal is often predictable.

A. Feed-forward Control Algorithms

1) *Broadband Feed-Forward ANC*: Broadband feed-forward control systems are utilized when the primary noise field has a broadband frequency response (e.g., road noise). The system identification framework of a basic single-input single-output (SISO) broadband feed-forward control system is illustrated in Figure 2. The primary path system function $P(z)$ consists of the acoustic response from the reference sensor location to the error sensor, and the secondary path system function $S(z)$ consists of a combination of (i) the electronic response between the adaptive filter $W(z)$ and the loudspeaker, and (ii) the acoustic response from the loudspeaker to the error microphone. If the secondary path transfer function is not taken in to account (i.e., $W(z) = P(z)$), the system will become unstable, because the error signal will not be correctly time-aligned with the reference signal. Since the primary path of a vehicle cabin is often dynamic, the role of the adaptive filter $W(z)$ is to continuously track the time variations in the primary noise source (through the reference signal $x(n)$) and minimize the residual error signal $e(n)$. The most common form of adaptive filters is the transversal filter using the least-mean-square (LMS) algorithm. From Fig. 2, the Z-transform of the error signal is

$$E(z) = (P(z) - S(z)W(z))X(z) \quad (2)$$

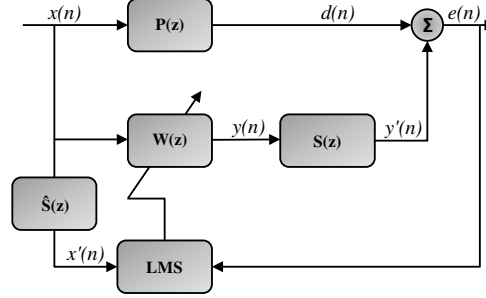

Fig. 3. Block diagram of a Feed-forward ANC system using the FXLMS algorithm.

In the ideal case, $E(z) = 0$ after the adaptive filter converges, which implies that the optimal filter response is $W(z) = P(z)/S(z)$. In order to achieve this result, the adaptive filter has to simultaneously model $P(z)$ and inversely model $S(z)$. Since an inverse does not always exist for $S(z)$, Morgan [13] suggested a more effective approach, where an identical filter (to $S(z)$) was proposed to be placed along the reference signal path to the weight update of the LMS algorithm. This modification compensates for the secondary path effects. It is also the origin of the well known filtered-X LMS (FXLMS) algorithm, for which the corresponding block diagram is given in Fig 3. The term $\hat{S}(z)$ in Fig 3 refers to an estimated value of the secondary path. For a more detailed derivation of the FXLMS algorithm, the reader is encouraged to refer to [3]. Another practical limitation that arises with feed-forward systems is the *effect of feed-back*. This involves the upstream of the anti-noise output from the secondary loudspeakers to the reference sensor, which corrupts the reference signal. The simplest approach to solving this problem is to model the feed-back path transfer function $F(z)$ and neutralize it with a separate feed-back cancellation filter [3]. However, this leads to additional stability issues in practice, and incorrect modeling of the feed-back path can lead to instability.

2) *Narrowband Feed-forward ANC*: Noises generated by mechanical components such as engines, compressors, motors and fans are generally narrowband and periodic. To monitor such noise, it is sufficient to use a non-acoustic sensor (e.g., tachometer), which provides an electrical reference signal that contains the fundamental frequency and all of the harmonics of the primary noise source. This technique has several advantages compared to a broadband ANC system using acoustic reference sensors; (i) effect of feed-back is eliminated (ii) aging and non-linearities associated with acoustic reference sensors are avoided, (iii) causality condition is preserved due to periodicity. In narrowband ANC systems, once an electric reference signal is available, a corresponding acoustic reference signal is internally generated to assist the noise cancellation process.

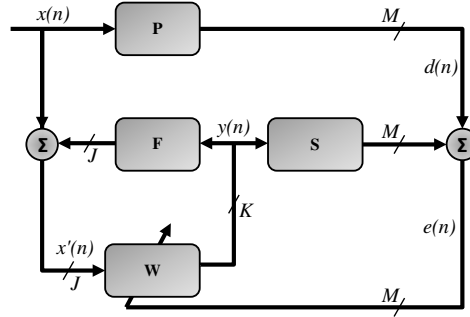

Fig. 4. Broadband adaptive MIMO feed-forward ANC system with feed-back and secondary paths.

3) *MIMO Feed-forward ANC*: When the noise field of interest increases in size and bandwidth, the number of active acoustic modes increases. To control multiple acoustic modes, it is necessary to use multiple-channel ANC systems with multiple secondary sources, error signals and reference signals. A MIMO feed-forward ANC system employs J reference sensors to observe the primary noise, M error sensors to measure the residual noise and K secondary sources to produce the anti-noise. Figure 4 illustrates the block diagram of a broadband adaptive MIMO feed-forward ANC system with feed-back and secondary path transfer functions. The wide arrows represent a flow of vectors (multi-channel acoustic or electrical signals). The matrix \mathbf{P} represents $M \times J$ primary path transfer functions, matrix \mathbf{S} represents $K \times M$ secondary path functions, matrix \mathbf{F} represents $K \times J$ feed-back path functions and \mathbf{W} represents a matrix of $K \times J$ adaptive filters each serving an individual feed-forward channel.

B. Application of Feed-forward Control to Car Noise Cancellation

In the application of car-noise cancellation, feed-forward ANC systems are mostly applied for engine noise cancellation. This is because it's easier to obtain a reference signal directly from the engine resulting in high coherence between the reference and error signals. Furthermore, as mentioned earlier, engine noise is often periodic. Therefore, ANC for engine noise is often approached via a cost-effective narrowband feed-forward system using an engine speed reference sensor, low-cost microphone error sensor(s) and the vehicle's in-built loudspeaker system as control sources. Such active noise control systems have been commercially implemented by a number of manufactures as discussed later in Section VI.

Ideally, noise cancellation inside a vehicle would require the total acoustic energy distributed over the entire global region to be minimized. Since this is an impractical task, the control region is often sampled using one or more error sensors distributed over the control region. The total acoustic energy to

be minimized is then approximated by the sum of squares of the sensor output as

$$J_p = \sum_{m=1}^M p_m^2 \quad (3)$$

where p_m is the sound pressure at the m^{th} error sensor position ($m = 1 \cdots M$). The effects due to the above approximation is often comparable for low frequency control but gets increasingly noticeable at high frequencies. The accuracy of the above approximation largely depends on the location of the error sensors because as mentioned in section II-B, noise field characteristics inside an enclosure are largely related to the enclosure's active number of acoustic modes and structural-acoustic coupling. The effects of structural-acoustic coupling on ANC inside vehicles have been thoroughly studied over the last 20 years [1], [14], [15]. In [1] Elliot et.al showed that at low frequencies, a single sensor is capable of achieving significant control, however with increasing complexity of the soundfield (frequency and geometry), multiple acoustic modes become active and therefore, multiple sensors are required to successfully couple into all of them. The frequency limit of global control was shown to be directly related to the *modal overlap* or the number of acoustic modes that are significantly excited at a given frequency f , which increases with cube of f . Therefore, in order to achieve control over the entire global region with a size of a car, the amount of sensors required are often impractical.

In order to improve the control bandwidth, an alternative control strategy was to be developed. Such a strategy was recently investigated in [6], [16], which attempts to control the soundfield within smaller spatial regions (regional control), particularly surrounding the driver's/passenger's head. Regional or local control of noise reduces the volume over which the noise energy has to be minimized and therefore reduces the constraints on the control system and increases the control bandwidth. In [6], the authors investigated a regional narrowband feed-forward system over two regions, one rectangular region across the front seats and a second rectangular region across the rear seats. The performance of the system was investigated through simulations and synthesis based on transfer functions measured in a rectangular car cabin mock-up. The control system comprised of four secondary sources positioned at the standard car audio loudspeaker positions, and eight error sensors positioned at the four head rest positions (two sensors on each headrest). The acoustic potential energy within the control regions were shown to be significantly reduced at frequencies up to 370 Hz. This is around twice the control bandwidth of global feed-forward control using a similar system. The authors mention a potential issue with the regional feed-forward control strategy, that is the system is said to be susceptible to unobservable modes that result in enhancements in the regional acoustic potential energy. However, it has also been shown that these effects can be limited by using control effort weighting parameters.

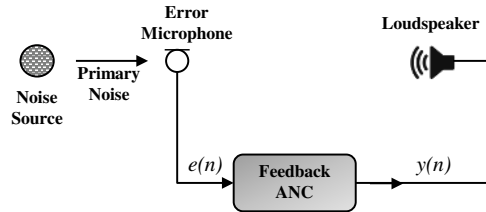

Fig. 5. A SISO adaptive feed-back ANC system.

In addition to engine noise cancellation, feed-forward systems are also applied in road noise cancellation. In [17], Oh et.al presented a leaky constraint MIMO feed-forward ANC system for road booming noise control in a mid-size passenger vehicle using 2 accelerometers, 2 control loudspeakers and a single error microphone. Based on experimental results, the optimum positioning for the above devices were chosen, and during driving tests on rough asphalt and turtle/back roads at 60 km/h, a reduction of 6-dB A -weighted sound pressure level (A -weighting accounts for the relative loudness perceived by the human ear) in the road booming noise was achieved. Due to the high cost of accelerometers, feed-forward ANC is generally regarded as unsuitable for mass production, however with the recent introduction of low-cost MEMS accelerometers, it is expected to change.

V. FEED-BACK CONTROL SYSTEMS

This section discusses the adaptive feed-back control systems used for broadband ANC. Unlike feed-forward systems, feed-back systems directly employ the signal(s) from error sensor(s) to drive the secondary source(s) via a controller. Since the error sensor signal is fed back to the secondary source, the system cannot be optimized on a frequency-by-frequency basis as in feed-forward control, and therefore, the whole frequency response (broadband) must be considered at all times. The performance of feed-back control systems are limited by their stability, which is largely dependent on the system delay. Therefore, the control bandwidth of feed-back control systems are inversely proportional to the spacing in between the error sensor(s) and secondary source(s).

A. Feed-back Control Algorithms

1) *SISO Feed-back Control*: A single channel adaptive feed-back ANC system, as shown in Fig 5, was first proposed in [18]. Based on the Internal Model Control (IMC) architecture, an adaptive feed-back system can be viewed as an adaptive feed-forward system, that synthesizes or regenerates its own reference signal using the error signal and the adaptive filter output. The basic concept of this model is

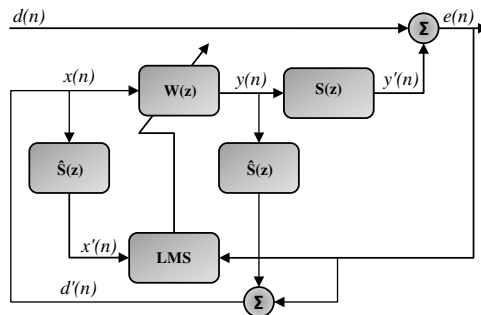

Fig. 6. A SISO adaptive feed-back ANC system using the IMC architecture.

to estimate the primary noise $d(n)$ present at the error sensor and use it as a reference signal $x(n)$ for the adaptive filter. If the secondary path transfer function $S(z)$ is known, the primary noise signal $d(n)$ can be synthesized using

$$X(z) \equiv \hat{D}(z) = E(z) + \hat{S}(z)Y(z) \quad (4)$$

where the notation $\hat{\cdot}$ represents an estimated value. Therefore, the reference signal synthesis technique filters the secondary source signal $y(n)$ using the secondary path estimate $\hat{S}(z)$ and combines it with $e(n)$ to regenerate the primary noise. Figure 6 shows a complete SISO feed-back ANC system using the FXLMS algorithm with secondary path cancellation as discussed in section IV-A1. When applying a feed-back control system, the overall control system stability is very important next to the noise reduction level. This is generally analyzed by checking the Nyquist stability criterion, which states that the polar plot of the open-loop response must not enclose the Nyquist point $(-1, 0)$ as ω increases from $-\infty$ to $+\infty$ [19]. In a practical system, since the open-loop response often varies with time, it is typical to set the feed-back gain to stabilize the system despite its variations. A system that stabilizes with such a gain is said to have robust stability.

2) *MIMO Feed-back Control*: The SISO feed-back ANC system is extendable to a multiple-channel system with K secondary sources and M error sensors. Such a system will have $M \times K$ secondary paths. Each path $S_{mk}(z)$ is from the k^{th} secondary source to the m^{th} error sensor, and needs to be estimated by a filter $\hat{S}_{mk}(z)$. These estimated filters along with the K secondary/control signals $y_k(n)$ and the M error signals $e_m(k)$ will synthesize M reference signals $x_m(n)$ for the corresponding $K \times M$ adaptive filters $W_{km}(z)$. A multiple channel FXLMS algorithms will be required to calculate the coefficients of the adaptive filters. Figure 7 illustrates a block diagram of the entire process described above. In practice, the extension of a SISO feedback system to a MIMO feedback system is, somewhat complex due to the need to calculate the eigenvalues of the open-loop response in order to assess the controller stability.

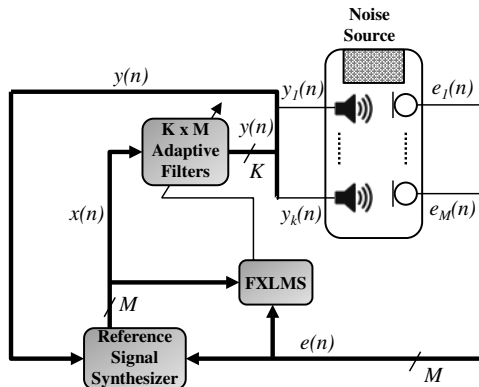

Fig. 7. A MIMO adaptive feed-back ANC system using M error sensors and K secondary sources.

B. Application of Feed-back Control to Car Noise Cancellation

Feed-back control is predominantly used to minimize the effects of road noise. Sano *et al* [5] designed and implemented a SISO feed-back control system for boom noise control of a Honda station wagon. The system mainly attempts to control the boom noise at 40 Hz present in the front seats of the car, which is due to the first acoustic longitudinal mode of the vehicle's enclosure. The feed-back system employs a single error microphone, positioned under the front seat and the two front door loudspeakers of the car's in-built speaker system (the two speakers are driven in-phase, hence the control system is SISO) to achieve noise reduction up to 10 dB. The authors observed an undesired side-effect in the rear seats, where the boom noise was increased by 3 dB. To avoid this, they proposed a simultaneous fixed feed-forward control system, which uses the previous system's error microphone as a reference signal to minimize the boom noise present at the rear seats. The secondary system utilized the two rear door loudspeakers from the vehicle's in-built speaker system driven in phase. This approach managed to achieve a 10 dB reduction of the boom noise at the front seats while avoiding the increase of sound level at the rear seats, where the boom noise is not significant.

Similar to feed-forward control, the performance of SISO feed-back control is largely limited by increasing frequency and the enclosure size. The theory involved with employing MIMO feed-back control for road noise control inside automobiles was first presented by Elliot and Sutton in [4]. Recent work on this approach including a practical investigation was carried out by Cheer *et al* in [6], [20], where the authors utilized a non-rigid car cabin mock-up. With 8 error sensors and 4 control sources, the MIMO system required a total of 32 FIR filters. The authors simulated road noise using uncorrelated structural vibrations for which the system managed to cancel an increased number of acoustic modes

compared to the modal feed-back controller. When the road noise was simulated using uncorrelated point sources, the system was capable of canceling all the active modes up to a control bandwidth of 100 Hz. The performance of the above system in a practical automobile environment was also investigated by Cheer *et al* [6], [19] inside a small city car. In this work, the authors utilized 16 error microphones (8 on the floor, with a pair near each tire and 8 on the seats, with a pair on each head-rest) and the 4 in-built door loudspeakers as control sources. The system performance was synthesized offline based on the transfer function measurements inside the car. The authors managed to achieve significant noise reduction up to 8 dB in the low frequency range and an average reduction of 3 dB between 80 – 200 Hz where the road noise is prominent.

As discussed in section IV-B, a recent approach [21] to improve control bandwidth and reduce system complexity is to simplify the global control requirement by regional control where the control region is shrunk to a small area around the head position(s). In [22], the authors implemented a regional feed-back control system in a Ford S-Max employing a horizontal grid array of 25 error microphones positioned in front of the headrest on the front passenger seat and two control loudspeakers mounted on the headrest. For 80 kmph smooth driving conditions, the regional control system achieved noise reduction up to 300 Hz. Also when the error was only averaged over 4 microphones close to typical ear positions, the control bandwidth was extended up to 500 Hz revealing the potential advantages of regional control systems.

VI. COMMERCIAL SYSTEMS

In the commercial automotive space, noise control is still predominantly achieved via passive control. However, to overcome limitations related to passive control, more companies are increasingly applying active control to mass production. Commercial active control systems are typically applied for both noise and vibration control. While ANC utilizes an acoustic system, AVC typically comprises of an active engine mount (ACM), which not only reduces vibrations but also reduces noise inside the cabin. More recently, the concept of active sound control (ASC) was introduced to commercial automotive solutions, which improves the driving experience by synthesizing certain sounds that are essential for the perceptual sound quality inside/outside the car. This process, which is similar to ANC, typically uses adaptive algorithms to change the coefficients of a set of digital filters such that not only are some selected frequencies canceled by secondary loudspeaker(s) generating an inverse disturbance signal(s), but others are controlled to a predetermined level, or even enhanced [12], [23]. In this section, we present the chronological advancement of active control in commercial automotive applications with the main focus on ANC.

Research and development of ANC became popular in the latter half of 1980 [1]. The earliest ANC systems were feed-forward arrangements based on MIMO FxLMS for tonal engine noise (or booming noise) control inside cars [24]. Implementation of such a system was initially carried out in collaboration with University of Southampton and Lotus Engineering, where 4 loudspeakers were adjusted at the engine's firing frequency and its harmonics to minimize the mean-square pressure at 8 error microphones located on the head-rests [25], [26]. ANC in mass production vehicles was first introduced by Nissan in 1991 [27] for booming noise, where a limited grade Nissan mid-size car was optionally installed with a separate ANC system, that consisted of additional loudspeakers, microphones and a MIMO FxLMS control system. The cost of implementation was quite high and the resulting level of noise reduction was not deemed to be significant. Therefore, at the time, it was not generally accepted as a useful technology.

In addition to engine booming noise reduction, research has also been actively carried out on road noise reduction since early 1990s [28], [29]. In 2000 Honda introduced ANC for low-frequency narrow band road noise control. It was applied as standard equipment in a station wagon, where a fixed feedback controller based on control engineering theory was utilized [5].

Nearly a decade after Nissan's attempt, commercial interest in engine booming noise reduction started re-gaining attention due to the integration of the ANC system to the vehicle's in-built audio system. In 2003, Honda introduced ANC for booming noise caused by the Honda V6 engine model, which employed the variable cylinder management (VCM) technology to improve fuel economy by providing three-cylinder operation [30], [31]. This ANC system employed an adaptive notch filter based MIMO feed-forward controller and was combined with an active control engine mount (ACM) to reduce vibrations. Currently all VCM engine models from Honda are equipped with ANC and ACM. In 2006, Honda combined an ASC system with their existing ANC solution for engine booming noise control. The ASC system was introduced to improve the internal cabin sound by synthesizing engine acceleration sounds for speeds above 2500 rpm such that it delivers a sporty feel to the driver [32]. In 2008, both Toyota [33] and GM introduced ANC for booming noise in a mid-size car and a mid-size SUV respectively. Both solutions were based on adaptive MIMO feed-forward controllers. Soon after in 2009, Nissan re-introduced a MIMO ANC system based on adaptive feed-forward control for engine booming noise in a mid-size car [34]. In 2011, Honda introduced commercial solutions for low frequency road noise by integrating an extra feedback controller (adaptive notch filter) to their existing booming noise controller (MIMO feed-forward) [35]. In the frequency range below 100 Hz, this system is claimed to achieve 10 dB reduction of noise level inside a mid-size car [36] (See Fig. 8). The aforementioned road noise controller by Honda was recently (2015) updated with an expanded low frequency range [37].

In addition to the ANC solutions provided by automobile manufacturers, leading audio system de-

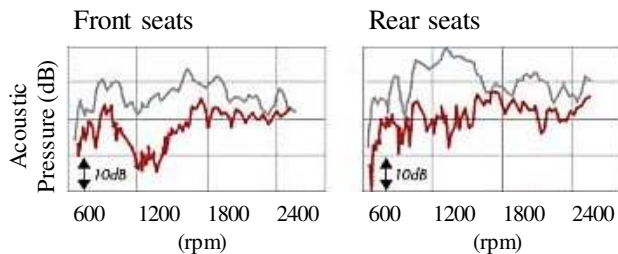

Fig. 8. Noise reduction levels of the HONDA ANC system at front seats and rear seats, adopted from [35], [36].

velopers such as Bose and Harman have also developed noise management solutions for automobiles. The Bose[®] Active Sound Management System (ASM) is an example for such a solution [38]. The main technologies used in ASM are Bose Engine Harmonic Cancellation (EHC), Bose Engine Harmonic Enhancement (EHE) and Bose Rapid Mode Transition (RMT). The EHC technology is an ANC solution that minimizes booming noise utilizing a feed-forward control system [39]. The EHE and RMT systems are both ASC solutions that synthesize artificial sound to improve the driving experience. The EHE technology provides desirable linear sounds (or sporty) by masking sound anomalies that occur during acceleration [40] while the RMT technology provides additional control parameters to synthesize a seamless sound experience during variable powertrain and cabin modes (e.g., cylinder deactivation/reactivation, hybrid operation) [38]. Bose ASM was previously available only for vehicles with Bose sound system hardware however, since 2013, it was released as a software solution integrated in a chip for global auto manufacturers. Currently, Bose ASM is integrated in vehicles manufactured by GM, Nissan, Audi [41], Porsche etc., particularly in their luxury divisions.

Introduced recently in 2015, HALOsonic[™] is another commercially available noise management solution provided by *Harman International* and *Lotus Cars*, which comprises of a suite of four technologies to enhance the in-car audible environment and improve pedestrian safety [42], [43]. The two technologies directly related to ANC are the Road Noise Cancellation (RNC) system and the Engine Order Cancellation (EOC) system. The RNC system is a broadband feed-forward control system with accelerometers as reference sensors. It is based on road noise cancellation solution originally presented in [28]. The HALOsonic[™] EOC system, is a combined system with feed-forward control to reduce noise due to engine rotations and a feed-back controller to reduce noise due to internal combustion engine and exhaust components. Note that the design and specifications of the above systems may vary based on the size, shape and cost of the vehicle model of interest. The remaining two technologies of HALOsonic[™] focus on ASC or electric sound synthesis in quiet cars (e.g., electric cars, hybrid cars). This is done in

two areas; (i) internally, to improve the passenger experience and (ii) externally, to improve the safety of pedestrians. The internal (iESS) system helps synthesize an exhilarating engine sound that adds a very emotional element to the overall driving experience. It helps reinstate original engine sound in case of sound loss due to OEM features such as downsized engines and the use of turbochargers. iESS also offers multiple engine sound modes (for example normal, moderate and sporty engine sound) for the same car, thereby enhancing car occupants' emotional experience. The external (eESS) system mainly provides safety to quieter cars, where active system is optimized to operate in urban environments with the greatest risk of a collision with pedestrians, especially high-risk groups such as the elderly, children, cyclists, and particularly the blind and their guide dogs. eESS helps automakers comply with governmental safety regulations. The sound of a car engine is an integral part of the experience behind the wheel and plays a crucial role in defining the DNA of the car. eESS is capable of creating custom-designed engine sounds, thereby helping to retain an OEM-specific (Original Equipment Manufacturer) sound DNA for the car [42].

VII. PRACTICAL LIMITATIONS OF CURRENT ANC SYSTEMS

In this section, we discuss the main limitations related to mass production of ANC systems inside automobiles. As reviewed in [44], these include (i) effects due to constrained number of microphones/speakers, (ii) stability issues in feed-back control systems (iii) system latency (iv) uncertainties (v) ANC system integration issues and (vi) system production tuning issues. A brief discussion on each of the above constraints are as follows. Due to cost restrictions, the numbers of speakers and microphones employed in ANC systems are limited. Currently, a typical production set-up consists of 4 microphones and 4 – 5 speakers, which can only achieve global noise control over 30 – 250 Hz (the lower limit is determined by the speaker characteristics whereas the higher limit is determined by vehicle interior and component placement). Control up to at least 200 Hz is often desired because 200 Hz is equivalent to the firing frequency of an I4 engine at 6000 RPM, which is the dominant cause of booming noise. The active number of engine orders of a typical automobile is however much higher, and with new technologies like cylinder deactivation, there exist extra noise components that need to be addressed. Therefore, improved ANC performance requires increased numbers of microphones/speakers with increased computational requirements, memory, and higher tuning efforts due to the increased complexity.

Another practical constraint that affects the the performance of ANC systems, particularly employing feedback control loops, is stability. To minimize side-effects due to stability, it is important to carefully calculate the sensitivity function of the closed loop. At present, there exist advance modeling techniques to understand the system behavior through computer aided technology [41], which is expected to make

significant progress in the coming years. Within the working frequency range of an ANC System, another practical limitation that arises is system latency. This is the signal latency added by processes like A/D and D/A conversion, and DSP processing latency. It is a difficult task to pin-point the exact instance when system latency starts to deteriorate the ANC performance. In practice, an ANC system latency (latency in the microphone input-ANC processing-speaker output loop) of 2 ms is considered to be acceptable while 3 ms is the upper limit to avoid significant degradation [44]. ANC performance in realistic automobile cabins, is often affected by uncertainties such as number and placement of seated passengers, opening and closing of windows/doors, and vehicle interior production tolerances. To ensure consistent ANC performance, it is important to improve system robustness while minimizing uncertainties. The typical approach to achieve this is via measuring and modeling different components of overall uncertainty as accurately as possible under realistic conditions, and setting the ANC system parameters to guarantee robustness.

In addition to the aforementioned concerns, another key aspect that affects the implementation of ANC in production vehicles is integration of the ANC system to the existing audio system for parallel usage. Initially, ANC solutions were added as an extra control unit (DSP audio amplifier) causing no impact on the existing audio system, however it was soon deemed to be ineffective with regard to cost, weight and space. A subsequent ANC solution was to add some dedicated processing resources for ANC into the existing audio system (i.e, plug-in module for head unit with dedicated DSP), which omits the need for an additional control unit while minimizing added weight and space. A more recent and improved ANC solution is to fully integrate ANC in the form of software into the existing audio system. This is done by (i) adding ANC as a software on the amplifier without extra processing unit (e.g., Analog devices' SHARC processor) or (ii) integrating functional software using System on Chip (SOC) solutions (e.g., NXP Chip for the Bose Active Sound Management System). While the commercial application of the above solutions are still limited, they are expected to be utilized more broadly in the near future. One more issue that affects ANC implementation in mass production vehicles is system tuning during production. This involves the measurement of secondary path transfer functions and determination of algorithm parameters such as the number of engine orders to cancel. With uncertainty issues mentioned above, and multiple available powertrains, it is important to tune the ANC system for each of the vehicle variants. This task requires a lot of time and man power and with increasing demand to shorten the vehicle development period, there is an urgent need to opt for advanced CAE technologies that enable faster tuning.

VIII. SPATIAL SOUNDFIELD CONTROL IN ACTIVE NOISE CONTROL

Up to this point, we have only discussed ANC techniques that model the noise field in terms of acoustic modes and structural-acoustic coupling. By now, it is common knowledge that the aforementioned ANC is effective at low frequencies, but have limitations at high frequencies due to increased requirement of microphones/speakers and related cost. Recently, research has been carried out to model noise fields in an alternative domain such that characteristics like sparsity can be exploited to bring down the minimum requirement of microphones/speakers. This concept is based on spatial soundfield control and initial research on this topic is described below.

Spatial soundfield control involves acoustic control over a continuous spatial region utilizing a finite set of transducers distributed over the region of interest. Two well developed techniques to achieve spatial soundfield control are *wavefield synthesis* [45] and *higher order ambisonics* (HOA) [46]. Currently, HOA is the only technique utilized for spatial noise cancellation inside automobiles, and therefore, the overview given in this section will be limited to HOA. HOA is conceptually based on the cylindrical/spherical harmonics based solution to the wave equation. This solution represents the incident pressure at any arbitrary point \mathbf{x} within a control region of radius R , with respect to its origin by [47]

$$p(\mathbf{x}, k) = \begin{cases} \sum_{n=-N}^N \alpha_n(k) J_n(kr) e^{in\phi} & \text{2D region with } \mathbf{x} = (r, \phi) \\ \sum_{n=0}^N \sum_{m=-n}^n \alpha_{nm}(k) j_n(kr) Y_{nm}(\theta, \phi) & \text{3D region with } \mathbf{x} = (r, \theta, \phi) \end{cases} \quad (5)$$

where $k = 2\pi f/c$ represents the wave number with f and c representing frequency and speed of sound respectively, α denotes the HOA harmonic coefficients, $J_n(\cdot)$ and $j_n(\cdot)$ represent the cylindrical and spherical Bessel functions of order n , respectively, $Y_{nm}(\cdot)$ denotes the spherical harmonic function and $N = \lceil kR \rceil$ is the summation's truncation limit (commonly referred to as *soundfield order*) derived based on inherent properties of Bessel functions. The main advantage of the above decomposition is it gives the ability to record or produce an entire continuous spatial soundfield by considering only a finite set of coefficients. When recording a spatial soundfield, these coefficients have a direct relationship with the microphone outputs in the form $\mathbf{P} = \mathbf{T}\boldsymbol{\alpha}$ where $\boldsymbol{\alpha}$ is a vector of recorded soundfield coefficients, \mathbf{T} is a transformation matrix and \mathbf{P} is a vector of microphone recordings. Similarly, when producing a soundfield, the above coefficients have a direct relationship with the loudspeaker driving signals in the form $\boldsymbol{\alpha} = \mathbf{T}_1 \mathbf{W}$, where $\boldsymbol{\alpha}$ is now a vector of desired soundfield coefficients, \mathbf{T}_1 is a transformation matrix and \mathbf{W} is a vector of loudspeaker driving signals. Generally, when recording/producing an N^{th} order soundfield, there exists a minimum requirement of $(2N + 1)$ or $(N + 1)^2$ sensors/loudspeakers for 2D and 3D soundfields, respectively. This is to avoid the undesired effects of spatial aliasing.



Fig. 9. Hardware setup for regional and spatial feed-back control.

When HOA based spatial soundfield control is occupied in active noise control, the residual field, the noise field and the secondary soundfield are first decomposed in to cylindrical/spherical harmonic coefficients. For example, in 3D ANC, the frequency transform of (6) is decomposed into

$$e_{nm}(k) = d(k)_{nm} + y'(k)_{nm}. \quad (6)$$

The input and output of the adaptive controller are therefore spherical harmonic coefficients rather than the direct error sensor outputs or control speaker weights. As a result, the standard block diagram for feed-forward and feed-back systems needs to be updated by additional modal transformation blocks. In [48], Spors *et al* designed and simulated a 2D HOA based massive feed-forward ANC system with 80 reference sensors, 80 error sensors and 80 loudspeakers, mainly for use in room noise cancellation. A 2D feed-back control system following the HOA technique was recently proposed by Zhang *et al* using 11 error sensors and 11 control sources [49]. This feed-back system was later extended with a sparse FXLMS controller, particularly for the use in spatially sparse noise fields [50]. The main advantage of HOA based ANC as observed in both feed-back and feed-forward systems mentioned above is the significant improvement of convergence time and the significant decrease of spatially averaged residual signal energy. However, due to the relationship $N = \lceil kR \rceil$, the minimum requirement of sensors/speakers to control a sizable enclosure is impractically high, especially if the system is to be utilized for noise reduction inside automobiles.

A. Application of Spatial Soundfield Control to Car Noise Cancellation

In [16], Chen *et al* investigated the applicability of spatial regional control in ANC inside automobiles. The main purpose of the study was to derive the performance bounds of a feed-back system with the automobile's in-built speakers utilized as control sources. Results were synthesized using a fixed offline

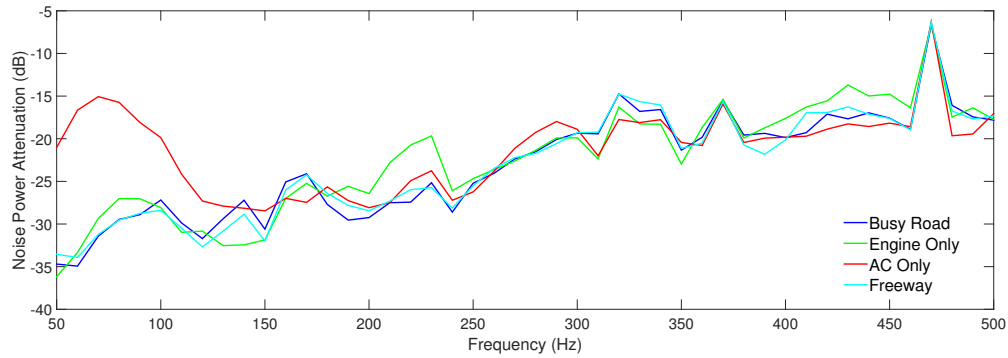

Fig. 10. Performance bounds of spatial ANC : Noise power spectrum attenuation for 4 different driving conditions.

system based on transfer functions and noise measurements done at the front-left headrest of a Ford Falcon XR6 (see fig. 9). The sensor array used was a commercially available 32-microphone spherical array (Eigenmike). While the previously discussed spatial ANC systems preferred a spherical array of control sources, the proposed system simplified this constraint to the vehicle's own audio system, based on a novel model for the primary noise field. This model was derived utilizing the spherical harmonic decomposition of the recorded noise field such that it represents the primary noise field in terms of an alternative set of basis functions. Based on a diverse set of noise measurements obtained inside the car (e.g., engine only, AC only, road noise at specific speeds) the authors, found out that the noise field inside a vehicle is generally sparse in terms of the proposed noise model. In fact, for the head-sized region of interest, it was observed that only a single noise mode was active at all times. Therefore, it was predicted that the vehicle's in-built 2 channel audio system (Ford Falcon XR6 has 4 loudspeakers with stereo control) will be sufficient to attenuate the active noise mode. Figure 10 shows the noise reduction observed over frequency for 4 different driving conditions, where it's observed that noise reduction is relatively consistent with the attenuation levels varying between 35 – 15 dB across 50 – 500 Hz. These results are quite promising in terms of the potential use of a vehicle's own audio system for effective ANC. A robustness analysis of this system however is still to be carried out. The theory of the above design was later extended to support multiple-region ANC control and tested in the same vehicle [51]. From this investigation the authors concluded that a vehicle's integrated loudspeakers when used as a stereo system, are only capable of canceling the noise field up to 200 Hz at the head positions of two seats simultaneously. To achieve similar reductions over 4 headrest positions simultaneously, a minimum of four individually driven loudspeakers were said to be needed.

IX. SUMMARY AND FUTURE DIRECTIONS

In this article, a compact tutorial of ANC techniques was presented with a review of their application in reducing undesired noise inside automobiles. Some of the recent advances have demonstrated significant improvements in the noise reduction levels as well as the cost and implementation complexity. While the techniques discussed above may individually focus on a particular noise field (e.g., road noise only, engine noise only), it is proven through research and commercial products that a combination of these strategies can deliver significant benefits in realistic conditions.

Future opportunities for improving in-car ANC exist in (i) cost reduction (ii) practical implementation and commercialization of regional sound field control (iii) integration of regional ANC with future in-car infotainment systems and (iv) researching on alternative noise modeling techniques to bring down the system components. At present, main drivers for cost are hardware components, particularly the extra requirement for error/reference microphones and control loudspeakers. With the introduction of MEMS microphones, and MEMS loudspeakers (e.g., Audio Pixels [52]), technically feasible low-cost ANC systems could be introduced, possibly with better performance. As mentioned earlier, regional ANC is a well researched topic that could reduce the overall system requirements. Regional ANC can be also extended for multiple-regions serving individual passengers. Practical implementation and commercialization of these solutions are still minimal and has potential to reduce costs and improve efficiency. With the current global trend of instant connectivity, vehicles are evolving to provide infotainment systems rather than just radio. These include the availability of different wireless interfaces including WiFi, Bluetooth which forces all of the systems to move to digital. Future In-vehicle infotainment systems are predicted to be comprised of "center stack computers" [44] to process all types of media content and a network hub to serve multiple media/data streams, possibly on a per/seat, per/display basis. With the introduction of such systems, its essential for ANC to be re-introduced with appropriate low-latency audio processing that handles digital signals. Finally, another important future direction that could improve ANC efficiency is by looking for alternative modeling methods for the noise field inside the car. Even though the current ANC systems are largely restricted to low frequencies, an alternate model that describes noise fields in terms of a lower number of active modes may significantly enhance the system performance for the same number of microphones/speakers, specially when the noise field is directionally sparse.

REFERENCES

- [1] P. A. Nelson and S. J. Elliott, *Active control of sound*. Academic press, 1991.
- [2] G. Cerrato, "Automotive sound quality - powertrain, road and wind noise," *Sound and Vibration*, vol. 43, pp. 16–24, April 2009.

- [3] S. M. Kuo and D. R. Morgan, "Active noise control: a tutorial review," *Proceedings of the IEEE*, vol. 87, no. 6, pp. 943–973, 1999.
- [4] S. J. Elliott and T. J. Sutton, "Performance of feedforward and feedback systems for active control," *IEEE Transactions on Speech and Audio Processing*, vol. 4, no. 3, pp. 214–223, 1996.
- [5] H. Sano, T. Inoue, A. Takahashi, K. Terai, and Y. Nakamura, "Active control system for low-frequency road noise combined with an audio system," *IEEE Transactions on Speech and Audio Processing*, vol. 9, no. 7, pp. 755–763, 2001.
- [6] J. Cheer, "Active control of the acoustic environment in an automobile cabin," Ph.D. dissertation, University of Southampton, UK, 2012.
- [7] D. Thompson and J. Dixon, *Advanced Applications in Acoustics, Noise and Vibration*. London: Spon Press, 2004, ch. Vehicle noise, p. ch. 6.
- [8] D. Robinette, M. Grimmer, J. Horgan, J. Kennell, and R. Vykydal, "Torque converter clutch optimization: improving fuel economy and reducing noise and vibration," *SAE International Journal of Engines*, vol. 4, no. 2011-01-0146, pp. 94–105, 2011.
- [9] M. R. Schroeder, "Frequency-correlation functions of frequency responses in rooms," *The Journal of the Acoustical Society of America*, vol. 34, no. 12, pp. 1819–1823, 1962.
- [10] S. J. E. and M. E. Johnson, "Radiation modes and the active control of sound power," *Journal of the Acoustical Society of America*, vol. 94, pp. 2194–2204, 1993.
- [11] S. M. Kim, "Active control of sound in structural-acoustic coupled systems," Ph.D. dissertation, University of Southampton, UK, April 1998.
- [12] H. Sano, "Modern advancements in passive and active noise and vibration control technology in automobiles," in *Proc. InterNoise*, 2011.
- [13] D. R. Morgan, "An analysis of multiple correlation cancellation loops with a filter in the auxiliary path," *IEEE Transactions on Acoustics, Speech and Signal Processing*, vol. 28, no. 4, pp. 454–467, 1980.
- [14] J. Pan, C. Hansen, and D. Bies, "Active control of noise transmission through a panel into a cavity: I. analytical study," *The Journal of the Acoustical Society of America*, vol. 87, no. 5, pp. 2098–2108, 1990.
- [15] J. I. Mohammad, "The active control of random sound inside cars," Ph.D. dissertation, University of Southampton, 2006.
- [16] H. Chen, P. Samarasinghe, T. D. Abhayapala, and W. Zhang, "Spatial noise cancellation inside cars: Performance analysis and experimental results," in *2015 IEEE Workshop on Applications of Signal Processing to Audio and Acoustics (WASPAA)*. IEEE, 2015, pp. 1–5.
- [17] S.-H. Oh, H.-s. Kim, and Y. Park, "Active control of road booming noise in automotive interiors," *The Journal of the Acoustical Society of America*, vol. 111, no. 1, pp. 180–188, 2002.
- [18] L. Eriksson, "Recursive algorithms for active noise control," in *Proc. Int. Symp. Active Control of Sound Vibration*, 1991, pp. 137–146.
- [19] J. Cheer and S. J. Elliott, "Multichannel control systems for the attenuation of interior road noise in vehicles," *Mechanical Systems and Signal Processing*, vol. 60, pp. 753–769, 2015.
- [20] J. Cheer and S. Elliott, "Multichannel feedback control of interior road noise," in *Proceedings of Meetings on Acoustics*, vol. 19, no. 1. Acoustical Society of America, 2013, p. 030118.
- [21] S. J. Elliott, W. Jung, and J. Cheer, "The spatial properties and local active control of road noise," in *Proc. of Euro-noise*, 2015.
- [22] J. Cheer, S. Elliott, and W. Jung, "Sound field control in the automotive environment," *3rd International ATZ Automotive Acoustics Conference*, 2015.

- [23] L. E. Rees and S. J. Elliott, "Adaptive algorithms for active sound-profiling," *IEEE Transactions on Audio, Speech, and Language Processing*, vol. 14, no. 2, pp. 711–719, 2006.
- [24] S. Elliott, I. Stothers, P. Nelson, A. McDonald, D. Quinn, and T. Saunders, "The active control of engine noise inside cars," in *INTER-NOISE and NOISE-CON Congress and Conference Proceedings*, vol. 1988, no. 3. Institute of Noise Control Engineering, 1988, pp. 987–990.
- [25] S. J. Elliott, "A review of active noise and vibration control in road vehicles," *ISVR Technical Memorandum, 981*, 2008.
- [26] A. McDonald, S. Elliott, and M. Stokes, "Active noise and vibration control within the automobile," in *Proc. Int. Symp. Active Control of Sound Vibration*, 1991, pp. 147–156.
- [27] S. Hasegawa, T. Tabata, A. Kinoshita, and H. Hyodo, "The development of an active noise control system for automobiles," SAE Technical Paper, Tech. Rep., 1992.
- [28] T. J. Sutton, S. J. Elliott, A. M. McDonald, and T. J. Saunders, "Active control of road noise inside vehicles," *Noise Control Engineering Journal*, vol. 42, no. 4, 1994.
- [29] R. J. Bernhard, "Active control of road noise inside automobiles," in *INTER-NOISE and NOISE-CON Congress and Conference Proceedings*, vol. 1995, no. 5. Institute of Noise Control Engineering, 1995, pp. 21–32.
- [30] T. Inoue, A. Takahashi, H. Sano, M. Onishi, and Y. Nakamura, "NV countermeasure technology for a cylinder-on-demand engine-development of active booming noise control system applying adaptive notch filter," SAE Technical Paper, Tech. Rep., 2004.
- [31] H. Matsuoka, T. Mikasa, and H. Nemoto, "NV countermeasure technology for a cylinder-on-demand engine–development of active control engine mount," SAE Technical Paper, Tech. Rep., 2004.
- [32] Y. Kobayashi, T. Inoue, , A. Takahashi, and K. Sakamoto, "Active sound control in automobiles," in *INTER-NOISE and NOISE-CON Congress and Conference Proceedings*, vol. 2008, no. 4. Institute of Noise Control Engineering, 2008, pp. 5001–5009.
- [33] H. Morita, T. Mochizuki, and H. Yoshida, "Development of active noise control-mechanism analysis and countermeasure of the waterbed phenomena," in *Society of Automotive Engineers of Japan Annual Congress*, no. 20095561. Society of Automotive Engineers of Japan, 2009, pp. 15–18.
- [34] N. Masahiro, O. Daisuke, H. N. Yoshiharu Nakaji, M. Masahiro, and H. Mineura, "Development of anc technology for reconciling acceleration sound with fuel economy and quietness," in *Society of Automotive Engineers of Japan Annual Congress*, no. 20105357. Society of Automotive Engineers of Japan, 2010, pp. 7–10.
- [35] A. Takahashi, T. Inoue, K. Sakamoto, and Y. Kobayashi, "Integrated active noise control system for low-frequency noise in automobiles," in *INTER-NOISE and NOISE-CON Congress and Conference Proceedings*, vol. 2011, no. 6. Institute of Noise Control Engineering, 2011, pp. 2105–2113.
- [36] HONDA New Zealand. (2014) Honda active noise cancellation. [Online]. Available: <http://www.honda.co.nz/technology/driving/anc/>
- [37] K. Sakamoto and T. Inoue, "Development of feedback-based active road noise control technology for noise in multiple narrow-frequency bands and integration with booming noise active noise control system," *SAE International Journal of Passenger Cars-Mechanical Systems*, vol. 8, no. 2015-01-0660, pp. 1–7, 2015.
- [38] Bose Corporation. (2016) Bose active sound management technology. [Online]. Available: <http://www.bose.com/prc.jsp?url=/automotive/innovations/asm.jsp>
- [39] A. GANESHKUMAR, "Engine harmonic cancelling system and operating method thereof," September 2011. [Online]. Available: <http://www.sumobrain.com/patents/WO2011112417A1.html>
- [40] C. M. Hera, "Engine harmonic enhancement control," Nov. 3 2015, uS Patent 9,177,544.

- [41] R. Schirmacher, R. Kunkel, and M. Burghardt, "Active noise control for the 4.0 tfsi with cylinder on demand technology in audi's s-series," SAE Technical Paper, Tech. Rep., 2012.
- [42] HARMAN International. (2016) Halosonic noise management solutions. [Online]. Available: <http://www.halosonic.co.uk/>
- [43] ——. (2015) Halosonic: Fututre of sound. [Online]. Available: <http://harmaninnovation.com/blog/halosonic-future-sound/>
- [44] R. Schirmacher, "Current status and future developments of anc systems," *SAE International Journal of Passenger Cars-Mechanical Systems*, vol. 8, no. 2015-01-2223, pp. 892–896, 2015.
- [45] S. Spors, R. Rabenstein, and J. Ahrens, "The theory of wave field synthesis revisited," in *124th AES Convention*, 2008, pp. 17–20.
- [46] D. B. Ward and T. D. Abhayapala, "Reproduction of a plane-wave sound field using an array of loudspeakers," *IEEE Transactions on Speech and Audio Processing*, vol. 9, no. 6, pp. 697–707, 2001.
- [47] E. Williams, *Fourier Acoustics: Sound Radiation and Nearfield Acoustic Holography*. London, UK: Academic Press, 1999, pp. 115–125.
- [48] S. Spors and H. Buchner, "Efficient massive multichannel active noise control using wave-domain adaptive filtering," in *3rd International Symposium on Communications, Control and Signal Processing, 2008. ISCCSP 2008*. IEEE, 2008, pp. 1480–1485.
- [49] J. Zhang, W. Zhang, and T. D. Abhayapala, "Noise cancellation over spatial regions using adaptive wave domain processing," in *2015 IEEE Workshop on Applications of Signal Processing to Audio and Acoustics (WASPAA)*. IEEE, 2015, pp. 1–5.
- [50] J. Zhang, T. D. Abhayapala, P. Samarasinghe, W. Zhang, and S. Jiang, "Sparse complex fxlms for active noise cancellation over spatial regions," in *International Conference on Acoustics, Speech and Language Processing (ICASSP)*. IEEE, 2016.
- [51] H. Chen, P. Samarasinghe, and T. D. Abhayapala, "In-car noise field analysis and multi-zone noise cancellation quality estimation," in *2015 Asia-Pacific Signal and Information Processing Association Annual Summit and Conference (APSIPA)*. IEEE, 2015, pp. 773–778.
- [52] Audio Pixels Limited. (2016) Audiopixels technology. [Online]. Available: <http://www.audiopixels.com.au/index.cfm/technology/>



Prasanga Samarasinghe (prasanga.samarasinghe@anu.edu.au) received the B.E. degree (with first class honors) in Electronic and Electrical Engineering from the University of Peradeniya, Sri Lanka in 2009. She completed the Ph.D. degree at the Australian National University (ANU), Canberra in 2014. She is currently working as a Research Fellow at the Research School of Engineering at ANU, and her research interests include spatial audio, active noise control and multi-channel signal processing.



Wen Zhang (wen.zhang@anu.edu.au) received the B.E. degree in telecommunication engineering from Xidian University, Xi'an, China, in 2003, the M.E. degree (with first class honours) and the Ph.D. degree from the Australian National University, Canberra, in 2005 and 2010, respectively. From 2010 to 2012, she was a Postdoctoral Fellow at CSIRO Process Science and Engineering in Sydney, Australia. She is currently working as a Research Fellow in the College of Engineering and Computer Science at the Australian National University. Her research interests include spatial audio, binaural source localization, and active noise control. She is awarded the Discovery Early Career Researcher Award (DECRA) fellowship by the Australian Research Council (ARC) in 2015.



Professor Thushara Abhayapala (thushara.abhayapala@anu.edu.au) received the B.E. degree (with Honors) in Engineering in 1994 and the Ph.D. degree in Telecommunications Engineering in 1999, both from the Australian National University (ANU), Canberra. Currently he is the Deputy Dean of the College of Engineering & Computer Science, ANU. He was the the Director of the Research School of Engineering at ANU from January 2010 to October 2014 and the Leader of the Wireless Signal Processing (WSP) Program at the National ICT Australia (NICTA) from November 2005 to June 2007. His research interests are in the areas of spatial audio and acoustic signal processing, and multi-channel signal processing. He has supervised over 30 PhD students and coauthored over 200 peer reviewed papers. Professor Abhayapala is an Associate Editor of IEEE/ACM Transactions on Audio, Speech, and Language Processing. He is a Member of the Audio and Acoustic Signal Processing Technical Committee (2011-2016) of the IEEE Signal Processing Society. He is a Fellow of the Engineers Australia (IEAust).