

NASA Technical Memorandum 101291

Recent Advances in Capacitance Type of Blade Tip Clearance Measurements

(NASA-TM-101291) RECENT ADVANCES IN
CAPACITANCE TYPE OF BLADE TIP CLEARANCE
MEASUREMENTS (NASA) 18 p CSCI 21E

N88-25460

G3/07 Unclas
0151355

John P. Barranger
Lewis Research Center
Cleveland, Ohio

Prepared for the
Conference on Sensors and Measurement Techniques
for Aeronautical Applications
sponsored by the American Institute of Aeronautics and Astronautics
Atlanta, Georgia, September 7-9, 1988

NASA

RECENT ADVANCES IN CAPACITANCE TYPE OF BLADE TIP CLEARANCE MEASUREMENTS

John P. Barranger
NASA Lewis Research Center
Cleveland, Ohio

Abstract

Two recent electronic advances at the NASA Lewis Research Center that meet the blade tip clearance needs of a wide class of fans, compressors, and turbines are described. The first is a frequency modulated (FM) oscillator that requires only a single low-cost ultra-high-frequency operational amplifier. Its carrier frequency is 42.8 MHz when used with a 61-cm (24-in.) long hermetically sealed coaxial cable. The oscillator can be calibrated in the static mode and has a negative peak frequency deviation of 400 kHz for a typical rotor blade. High temperature performance tests of the probe and 13 cm (5 in.) of the adjacent cable show good accuracy up to 600° C (1110° F), the maximum permissible probe seal temperature. The major source of error is the residual FM oscillator noise, which produces a clearance error of $\pm 10 \mu\text{m}$ (0.4 mil) at a clearance of 500 μm (20 mils). In the second advance, a guarded probe configuration allows a longer cable length (6 meters (20 ft.)) and provides immunity to environmentally induced changes in cable capacitance. The capacitance of the probe is part of a small time constant feedback in a high speed operational amplifier. The solution of the governing differential equation is applied to a ramp type of input. The results show an amplifier output that contains a term which is proportional to the derivative of the feedback capacitance. The capacitance is obtained by subtracting a balancing reference channel followed by an integration stage. Unlike some other capacitance feedback techniques, this ramp-integration method has static calibration capability.

Introduction

The need for blade tip clearance instrumentation has been intensified recently by advances in the technology of gas turbine engines. Improved engine designs encompass light-weight high-performance concepts such as small, thin airfoils for blades. Excess blade tip clearance allows a portion of the engine gas to flow over the blade tip without performing useful work. Moreover, insufficient clearance may cause interference that can jeopardize engine integrity.

Measurement of blade tip clearance is important to the design, development, and operation of fans, compressors, and turbines. During the design phase computational codes are generated to predict engine behavior under operational conditions. Verification of these codes requires comparing predicted values with experimental measurements. Full engine component development mandates monitoring of blade tip clearance over the entire flight envelope. Finally, maximum engine efficiency during operational flight can only be achieved through active control of blade tip clearance.

Capacitance sensors are applied extensively to the measurement of blade tip clearance. The most widely used techniques are impedance voltage division,¹ operational amplifier feedback,² frequency modulation (FM) oscillation,^{3,4} phase shifting,^{5,6} Coulomb-charge conversion,⁷ and others.^{8,9}

In this paper, two recent electronic advances and their proposed measurement systems will be described: (1) the FM Oscillator System and (2) the Ramp-Integration System.

FM Oscillator System

System Description

The clearance measurement system (fig. 1) consists of an electronics unit, a coaxial connecting cable, and a capacitance probe. The electronics unit contains the FM oscillator and frequency discriminator electronics and the analog-to-digital converter. The output is a digital signal ready for further processing.

In the capacitance probe installation (fig. 2) the clearance d is defined as the distance between the rotor blade tip and the shroud. This is also the distance to the probe face since the probe is mounted flush with the shroud.

Terminal pair 1-1' (fig. 2) represents the connection between the end of the coaxial cable and the probe. The probe has coaxial construction, where the inner conductor is separated from the outer tube by an insulator. As shown in the figure the inner conductor can be in the form of a solid round rod or a wire terminated in a disk.

The capacitance looking into terminal pair 1-1' can be thought of as the sum of the capacitance of the probe alone and the capacitance introduced by the presence of the blade. To visualize this concept, imagine that two blades with different clearances pass under the probe. The total capacitance for the two blades as a function of time t would be $C(t)$, as shown in figure 3. Making the probe diameter much smaller than the interblade spacing results in $C(t)$ becoming equal to the capacitance of the probe alone between blade pairs. Let this probe capacitance be called C_0 . At the point of maximum capacitance

$$C_m = C_0 + C_b \quad (1)$$

where C_b is the blade capacitance. The value of C_b increases as d increases and is usually very small, typically 1 pF or less.

Oscillator Circuit

The probe and the coaxial cable are an integrated assembly in the FM oscillator (fig. 4). A wire terminating in a disk, as illustrated in figure 2(a), is the probe inner conductor. The probe is 0.81 cm (0.32 in.) in outside diameter and 1.5 cm (0.59 in.) long. The disk is 0.44 cm (0.17 in.) in diameter. The probe insulator is ceramic and is set back 0.64 cm (0.25 in.) from the probe face. The cable portion of the assembly is a high-temperature "semirigid" coaxial cable consisting of a stainless-steel-clad copper inner conductor separated by a silica dielectric. End seals maintain hermetic integrity up to 600° C (1110° F). The characteristic impedance of the cable is 50 Ω , and its distributed capacitance is 82 pF/in (25 pF/ft). The cable is 3.61 mm (0.142 in.) in

outside diameter and 61 cm (24 in.) long. Connection to the FM oscillator electronics is made via an SMA type of radiofrequency (RF) connector.

The NE5539 (fig. 4) is a low-cost, ultra-high-frequency operational amplifier fabricated in a monolithic, 14-pin integrated-circuit package. Electrical resonance is achieved by the network consisting of the inductor and its effective parallel capacitance, of which the blade capacitance is a part. Since there is no explicit feedback from the output of the amplifier, this kind of circuit is usually called a two-terminal negative resistance oscillator.

A 50-Ω resistor loads the output of the oscillator circuit across terminal pair 4-4' (fig. 4). The load can be the input impedance of the next stage or of a transmission line carrying the oscillator output to a remote location. Thus the operational amplifier acts as both an oscillator active element and a line driver.

An important aspect of FM oscillator design is the frequency of oscillation. The oscillating frequency when the probe is between blade pairs, that is, when $C(t) = C_0$, is defined as the carrier frequency f_c . Thus,

$$f_c = \frac{1}{2\pi} \left[\frac{1}{LC_p} \right]^{1/2} \quad (2)$$

where L is the inductance of the inductor and C_p is the total equivalent capacitance including C_0 which appears across terminal pair 3-3' (fig. 4).

The blade passing under the probe causes a small change in the carrier frequency, defined as the frequency deviation. The maximum carrier frequency change, defined as the peak frequency deviation Δf_c , is found from

$$\Delta f_c = -\frac{C_b}{4\pi C_p} \left[\frac{1}{LC_p} \right]^{1/2} \quad (3)$$

where C_b is the blade capacitance as previously denoted in equation (1) and illustrated in figure 3. The blade capacitance is small compared with C_p . After equation (3) is rearranged, C_b becomes

$$C_b = -4\pi\Delta f_c C_p \left[LC_p \right]^{1/2} \quad (4)$$

which expresses the basic relationship between the clearance as reflected in C_b and the quantities Δf_c , L and C_p .

Calibration and High Temperature Evaluation

The FM oscillator of figure 4 was calibrated in the static mode at room temperature. The rotor blade tip was 1.2 mm (0.047 in.) thick at its widest point and was 4.0 cm (1.6 in.) long. The clearance d was defined as the distance from the blade tip to the probe face. For the given probe size and blade thickness the negative peak frequency deviation at 1-μm (0.04-mil) clearance (fig. 5) was approximately 400 kHz, and the clearance range was approximately 1000 μm (0.04-in.).

The oscillator carrier frequency was 42.8 MHz. It should be noted that some important advantages over other FM oscillator designs result from the use of a carrier frequency within the range 30 to 50 MHz. A carrier frequency of less than 50 MHz allows the connecting cable to be at least twice as long as for

designs at 100 MHz (ref. 3). This is critical for high-temperature applications, where greater physical separation is required between the probe and the oscillator electronics. Furthermore, output filters for the frequency discriminator have greater attenuation at carrier frequencies above 30 MHz than in the 1- to 10-MHz range (ref. 4).

The probe and approximately 13 cm (5 in.) of the adjacent coaxial cable were heated from room temperature to 600 °C (1110 °F), the maximum permissible seal temperature. This heating resulted in a change of -55 kHz in the carrier frequency, or a -0.13 percent change in f_c . The clearance error δd due to the effects of high temperature (fig. 6) is less than $\pm 3 \mu\text{m}$ (0.1 mil) at a clearance of 500 μm (20 mils). A complete error analysis is included in reference 10.

Residual FM Oscillator Noise and Spin Tests

The residual FM oscillator noise and spin tests were conducted using the system of figure 7. An oscilloscope, a low pass (LP) filter, and a frequency discriminator (demodulator) with a 50-Ω input impedance were connected across terminal 4-4' (fig. 4). The filter accommodates the high rotor speeds associated with small engines, the signals from which may have frequency components as high as 1 MHz.

The oscilloscope display of the filter output signal (fig. 8) shows residual FM oscillator noise of approximately 2 kHz (peak-to-peak) or ± 1 kHz (peak). This corresponds to a clearance error δd representing the minimum level of detectable clearance for frequency deviation measurements (figs. 5 and 6). The error is $\pm 10 \mu\text{m}$ (0.4 mil) at a clearance of 500 μm (20 mils). Comparing the two curves in figure 6 shows that at larger clearances the clearance error is dominated by residual FM oscillator noise.

Spin tests were conducted on a bladed 11-cm (4.5-in.) diameter aluminum rotor driven by an air turbine. The four simulated blade tips were 1.6 mm (0.062 in.) thick and 9.52 mm (0.375 in.) long. Figure 9 is the oscilloscope display of the filter output signal for a single blade at a speed of 8000 rpm and a clearance of approximately 0.2 mm (8 mils).

Proposed FM Measurement System

In the proposed FM measurement system (fig. 10) a controller has inputs from an electronic shaft angle encoder ¹¹. (The encoder is described in greater detail in the ramp-integration method below). The analog-to-digital (A/D) converter is sampled at a constant rate of N samples per blade.

In addition to providing a blade-by-blade digital signal, the system must provide a means of correcting for the change in C_p caused by environmental and long term aging effects. This change is reflected in a change in f_c (eq. (2)). An automatic frequency control feedback loop detects the difference between the average oscillator frequency at $C(t) = C_0$ and a reference carrier frequency.

The oscillator frequency is measured by sampling the filter output signal between blade pairs with the once per blade signal from the controller and then filtering. The difference signal generates a voltage that drives a reverse biased PN junction diode (varactor) in the direction to maintain the oscillator at the reference carrier frequency and thereby sustain the shunt capacitance at C_p . It is estimated that the oscillator can be controlled to within

± 1 kHz of the reference frequency. Thus the change in f_c found at high temperature can be reduced from -0.13 percent to less than ± 0.003 percent, a negligibly small value.

The final processor determines Δf_c by subtracting the maximum from the minimum A/D converter output for each blade. The clearance is computed from the static calibration curve which had been measured and stored previously by providing an external simulated once per revolution signal.

Ramp-Integration system

System Description

The clearance system is the same as figure 1 except that the coaxial cable is replaced by a triaxial cable and the electronics unit contains a number of integrators and amplifiers. The capacitance probe (fig. 11) has a triaxial configuration, where the middle electrode acts as a guard ring.

The probe and the 6-meter (20-ft.) cable are connected to the feedback of a high speed operational amplifier as shown schematically in figure 12. The capacitance C_o is the output-to-input circuit capacitance but unlike the FM measurement system it does not include cable capacitances. The capacitance across the resistor R_2 changes with blade clearance, effectively changing the time constant of the feedback. This change in the time constant is measured to obtain the capacitance change by the method described below. A feature of the circuit in common with reference 7 is that the connecting cable capacitances appear across the input and output and not the feedback of the amplifier. Thus, the environmentally induced changes in cable capacitances have minimal effect on system performance. Moreover, longer cable lengths can be tolerated.

Circuit Analysis and Calibration

To formulate the governing differential equation, the capacitance $C(t)$ is defined as

$$C(t) = C_o + C_b(t) \quad (5)$$

and is placed in the feedback of an ideal operational amplifier (fig. 13). The resultant equation is

$$-\frac{dV_2(t)}{dt} = \frac{1}{C(t)} \left[\frac{V_1(t)}{R_1} + V_2(t) \left[\frac{1}{R_2} + \frac{dC(t)}{dt} \right] \right] \quad (6)$$

When V_1 is a ramp defined by

$$V_1 = K t \quad (7)$$

the approximate steady state solution¹² of equation (6) is

$$-V_2(t) = \frac{R_2}{R_1} \left[Kt - \frac{d}{dt} \left[KtR_2C(t) \right] \right] \quad (8)$$

where K is the slope of the ramp. In addition to the usual conditions required for the use of a steady state solution the time constant of the feedback ($R_2C(t)$) must also be small compared to the period of the highest significant frequency contained in $C_b(t)$. Substituting equation (5) in equation (8), results in

$$-V_2(t) = \frac{KR_2}{R_1} \left[t - R_2C_o - R_2 \frac{d}{dt} \left[tC_b(t) \right] \right] \quad (9)$$

A solution of equation (9) is required to find the desired quantity C_b . Since $t - R_2C_o$ is much larger than the term containing the derivative, the sensitivity would be improved if $t - R_2C_o$ were removed. A reference channel containing R_2 and $C_o + \Delta C_o$ where ΔC_o is the capacitance mismatch between channels is introduced (fig. 14). The output of the signal channel is subsequently subtracted from the reference channel and amplified by the differential amplifier. From figure 14 the output of the differential amplifier is

$$-V_d(t) = \frac{GKR_2^2}{R_1} \left[\frac{d}{dt} \left[tC_b(t) \right] - \Delta C_o \right] \quad (10)$$

and the output of the integrator is

$$V_o(t) = \frac{GKR_2^2 t}{R_1 \tau_i} \left[C_b(t) - \Delta C_o \right] \quad (11)$$

where τ_i is the time constant of the integrator.

The ramp-integration system can be calibrated in the static mode. From equation (11)

$$\Delta \left[\frac{V_o(t)}{t} \right] = \frac{GKR_2^2 C_b}{R_1 \tau_i} \quad (12)$$

where $\Delta(V_o(t)/t)$ is the change in $V_o(t)/t$ corresponding to the blade capacitance C_b .

Proposed Ramp-Integration Measurement System

The controller in the proposed ramp-integration measurement system (fig. 15) has inputs from the electronic shaft angle encoder. The encoder is a fast updating frequency synthesizer which among other things generates:

1. A number corresponding to the speed of the rotor, f_r (Hz).
2. A once per blade signal occurring M times per revolution where M is the number of blades on the rotor.
3. A preset number of N equally spaced pulses between blades at all speeds.

In order to maintain high sensitivity at all speeds the time constant of the ramp generator (integrator 1) is adjusted according to the relationship $\tau_g = 1/\alpha M f_r$ where α is constant during the revolution. Thus, the

slope becomes $\alpha V M f_r$ where V is a dc voltage and the ramp voltage is αV at $t = 1/M f_r$. The time constant τ_1 of integrator 2 is also adjusted to be a function of $1/M f_r$ to maximize sensitivity.

One of the most severe transient response requirements of the proposed system is the resetting of the integrators. A circuit of an approximately 10 μ second period ramp generator was tested using a video operational amplifier and an electronic switch. The oscilloscope display of the signals (fig. 16) shows that the resetting time is less than 1 μ second which is adequate for most high speed applications.

The final processor determines $\Delta(V_o(t)/t)$ (eq. 12) by dividing the A/D converter output by t and then subtracting the maximum from the minimum for each blade. The time t corresponds to the converter time found from

$$t = \frac{j}{f_r M N}, j = 1, \dots, N \quad (13)$$

Finally, the static calibration curve which had been measured and stored previously by providing an external simulated once per revolution signal, is used to compute the clearance.

Conclusion

The FM oscillator system should find applications in small engines where small probes are necessary and short cable lengths can be tolerated. On the other hand, the ramp-integration measurement system should be more suitable to large engines where long cable lengths are necessary and larger probes can be tolerated. The proposed FM oscillator blade tip clearance measurement system is closer to a practical implementation than the proposed system for the ramp-integration technique. The latter requires a noise error analysis to determine the minimum level of detectable clearance. Moreover, high speed switches to control integrator time constants and reset action need to be investigated.

References

1. Barranger, J.P., "In-Place Recalibration Technique Applied to a Capacitance-Type System for Measuring Rotor Blade Tip Clearance," NASA TP-1110, 1978.
2. Doebelin, E.O., *Measurement Systems: Application and Design*, McGraw-Hill, New York, 1966, p. 254.
3. Mayer, R., "Apparatus for Measuring Blade-Die Spacing in a Pelletizer Including Rotating Capacitor Blade," US Patent 3,428,889, Feb. 18, 1969.
4. Wobschall, D., *Circuit Design for Electronic Instrumentation*, McGraw-Hill, New York, 1979, p. 139.
5. Scotto, M.J., and Eismeier, M.E., "High-Speed Non-contacting Instrumentation for Jet Engine Testing," *Journal of Engineering for Power*, Vol. 102, No. 4, Oct. 1980, pp. 912-917.
6. Demers, R.N., "Compressor Blade Clearance Measurement Using Capacitance and Phase Lock Techniques," *Advanced Instrumentation for Aero Engine Components*, AGARD CP-399, AGARD, Neuilly-Sur-Seine, France, 1986, pp. 30-1 to 30-10.
7. Knoell, H., and Ding, K., "Tip Clearance Measurement in Modern Compressor Components," *Advanced Instrumentation for Aero Engine Components*, AGARD CP-399, AGARD, Neuilly-Sur-Seine, France, 1986, pp. 29-1 to 29-10.
8. Jonas, R.P., "Means for Measuring Clearances in a Gas Turbine Including a Coaxial Cable Capacitor," US Patent 3,628,136, Dec. 14, 1971.
9. Paulon, J., "Influence et Mesure du Jeu en Bout D'Aubes dans les Turbomachines (The Effect and Measurement of Blade Tip Clearance in Turbomachinery)," *Heat Transfer and Cooling in Gas Turbines*, AGARD CP-390, AGARD, Neuilly-Sur-Seine, France, 1985, pp. 34-1 to 34-8.
10. Barranger, J.P., "Low-Cost FM Oscillator for Capacitance Type of Blade Tip Clearance Measurement System," NASA TP-2746, 1987.
11. Technical Information Manual, *Electronic Shaft Angle Encoder*, Model 371. Real Time Systems, Inc., Mount Vernon, NY, Sept. 1978.
12. Sarma, G.R., and Barranger, J.P., "Ramp-Integration Technique for Capacitance-Type Blade-Tip Clearance Measurement," NASA TM-87241, 1986.

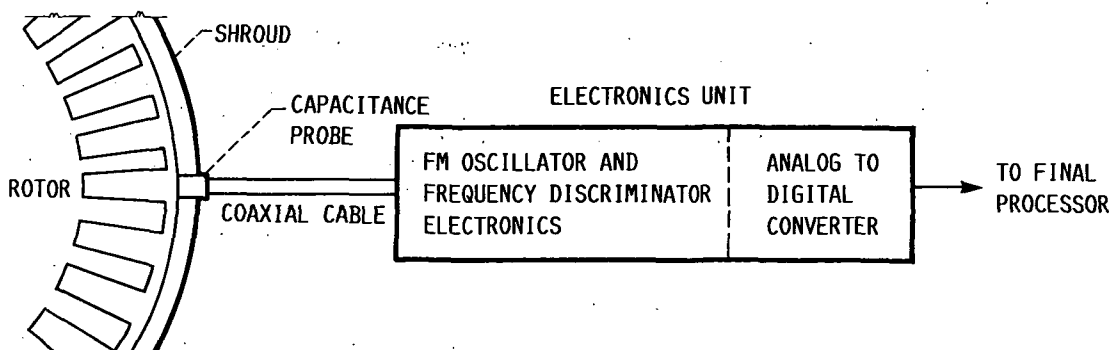

FIGURE 1. - SIMPLIFIED BLOCK DIAGRAM OF BLADE TIP CLEARANCE MEASUREMENT SYSTEM.

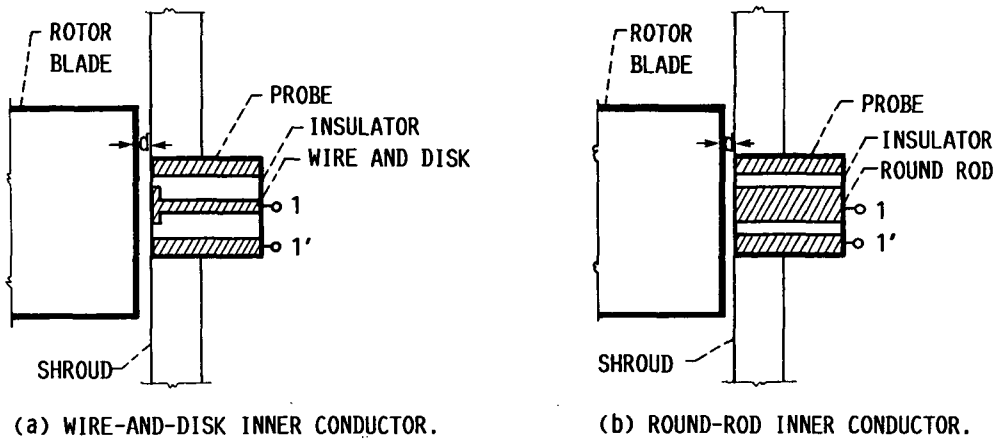

FIGURE 2. - SCHEMATIC OF CAPACITANCE PROBE INSTALLATION.

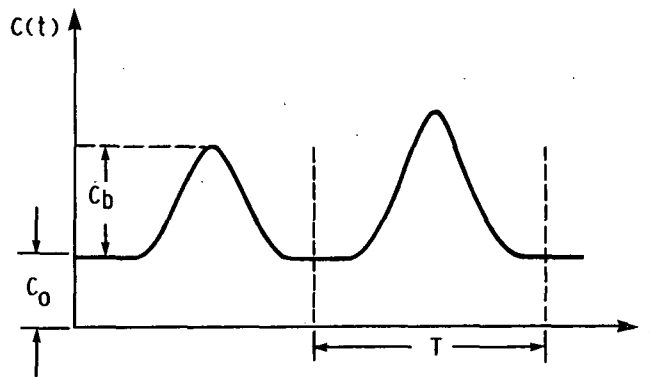

FIGURE 3. - CAPACITANCE AS FUNCTION OF TIME FOR PASSING OF TWO BLADES UNDER PROBE TIP.

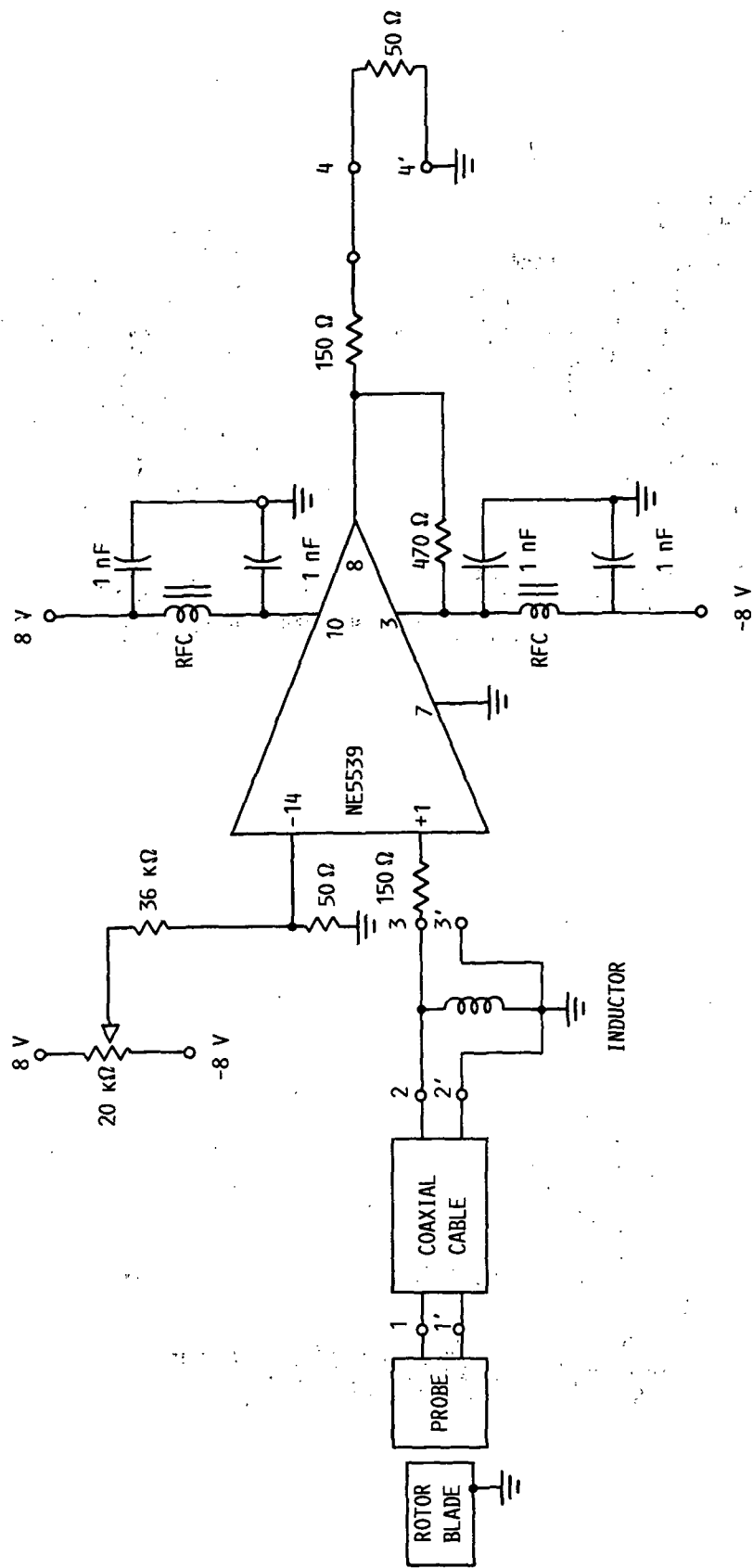

FIGURE 4. - SCHEMATIC OF FM OSCILLATOR. INDUCTOR: 0.17 TO 0.27 μ H, ADJUSTABLE (MILLER 4301); RADIOFREQUENCY CHOKE (RFC): THREE TURNS OF NUMBER 26 BUS WIRE ON FERROXCUBE VK 200 09/3B CORE.

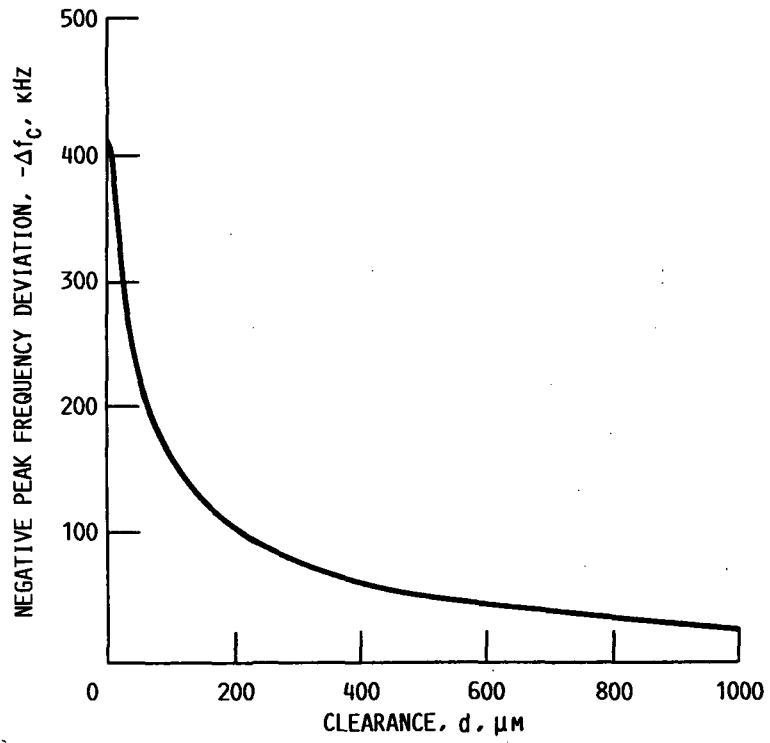

FIGURE 5. - CALIBRATION CURVE.

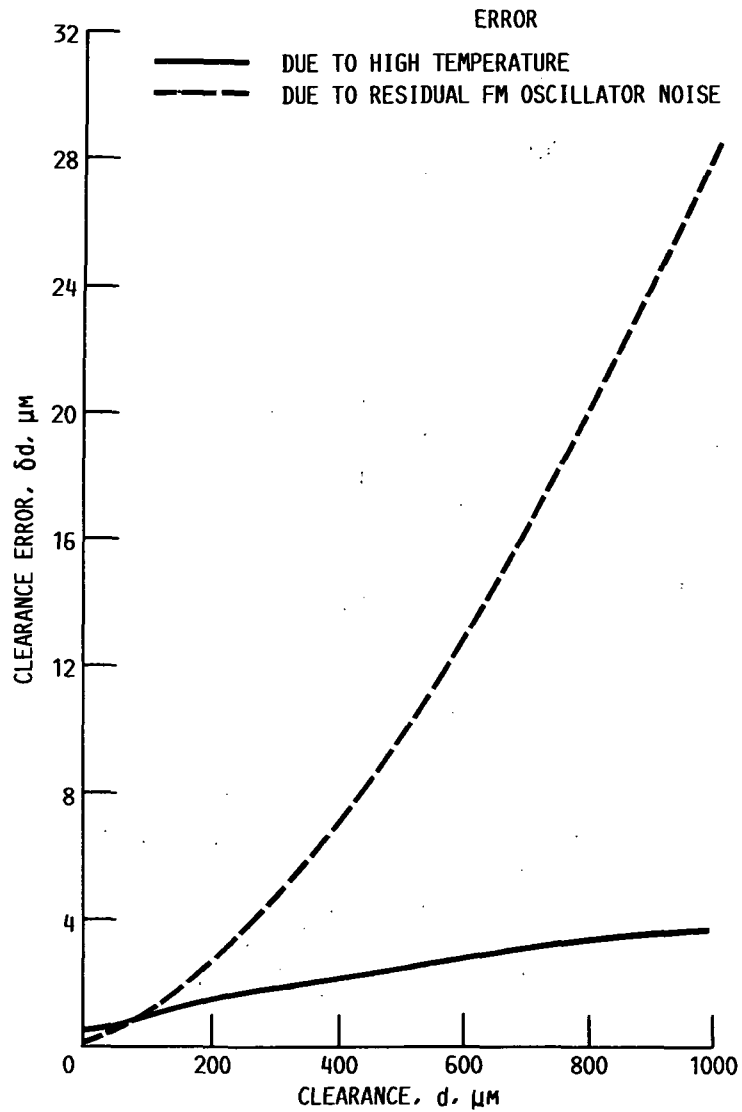

FIGURE 6. - CLEARANCE ERRORS DUE TO EFFECTS OF HIGH TEMPERATURE AND RESIDUAL FM OSCILLATOR NOISE.

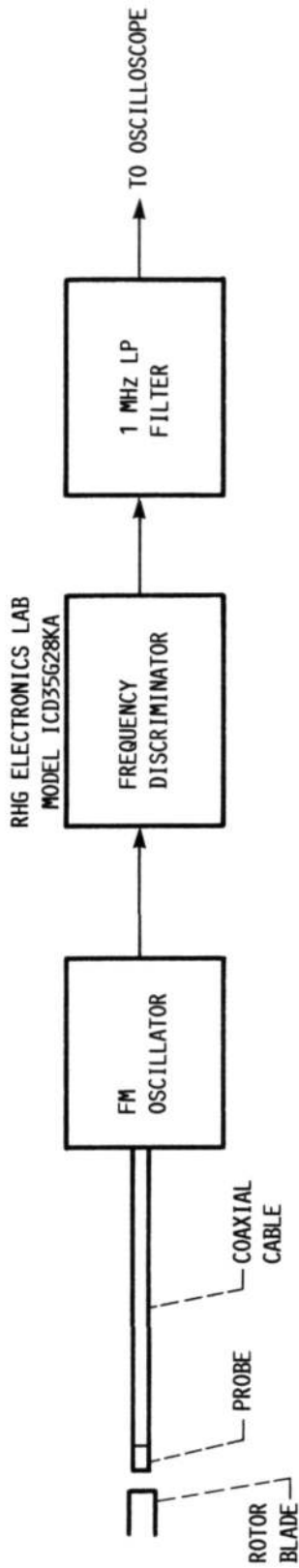

FIGURE 7. - RESIDUAL FM OSCILLATOR NOISE AND SPIN TEST SYSTEM.

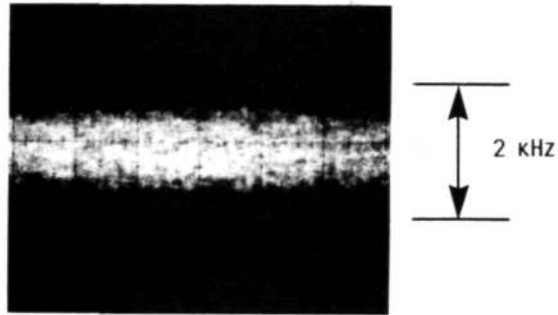

FIGURE 8. - FILTER OUTPUT SHOWING RESIDUAL FM OSCILLATOR NOISE. (VERTICAL SCALE, 1.0-KHZ DEVIATION/DIVISION; HORIZONTAL SCALE, 100 μ SEC/DIVISION.)

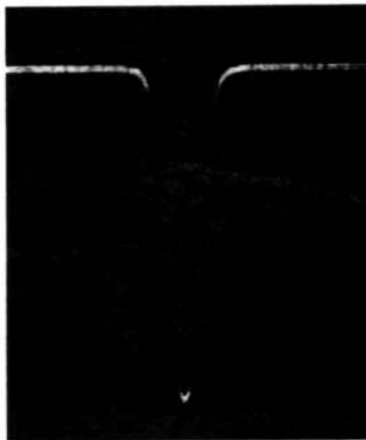

FIGURE 9. - SPIN TEST FILTER OUTPUT AT 8000 RPM. (VERTICAL SCALE, 20-KHZ DEVIATION/DIVISION; HORIZONTAL SCALE, 100 μ SEC/DIVISION.)

ORIGINAL PAGE IS
OF POOR QUALITY

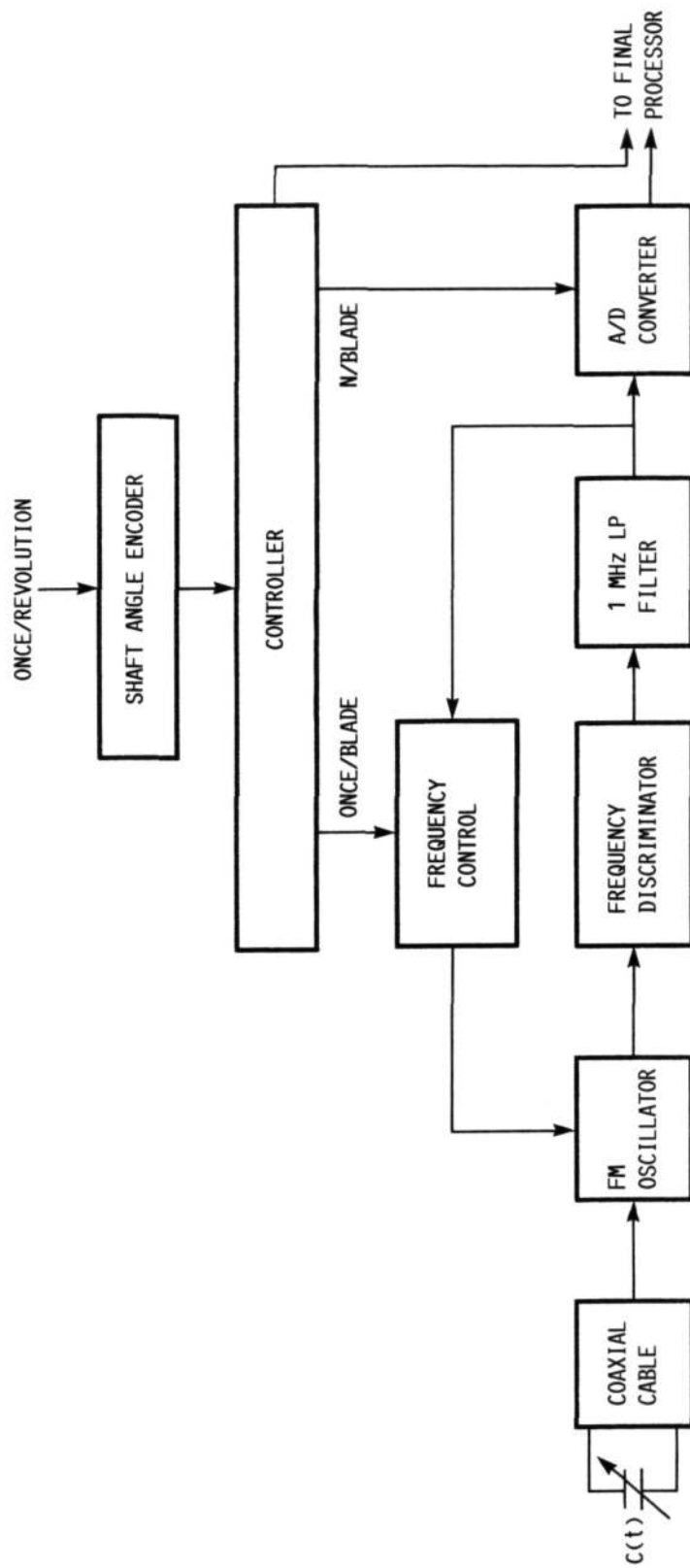

FIGURE 10. - BLOCK DIAGRAM OF PROPOSED FM BLADE TIP CLEARANCE MEASUREMENT SYSTEM.

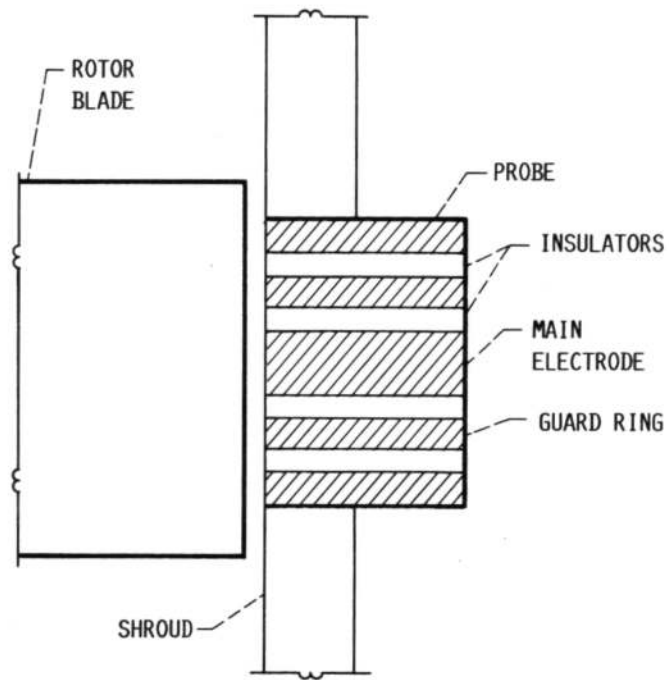

FIGURE 11. - SCHEMATIC OF TRIAXIAL CAPACITANCE PROBE INSTALLATION.

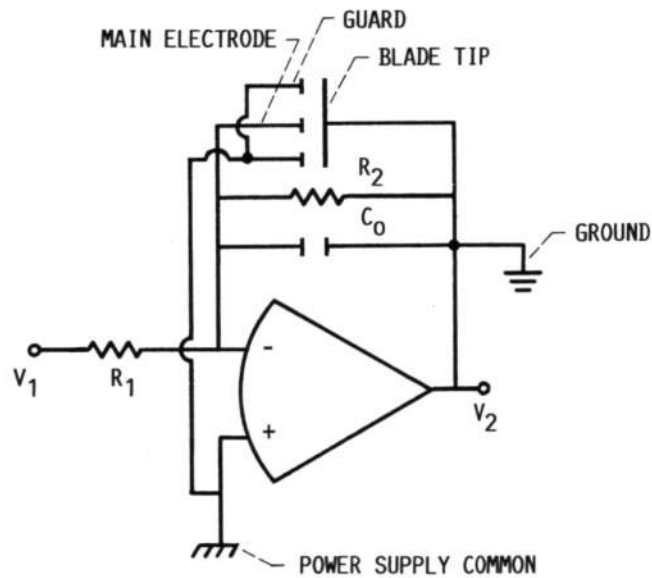

FIGURE 12. - SCHEMATIC OF PROBE AND CABLE CONNECTION TO FEEDBACK OF OPERATIONAL AMPLIFIER.

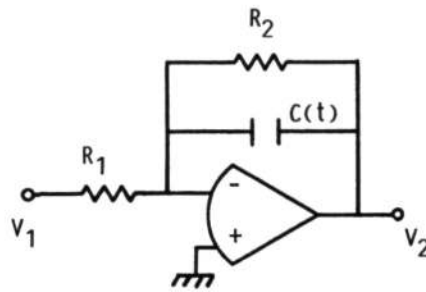

FIGURE 13. - IDEAL OPERATIONAL AMPLIFIER WITH FEEDBACK ELEMENTS.

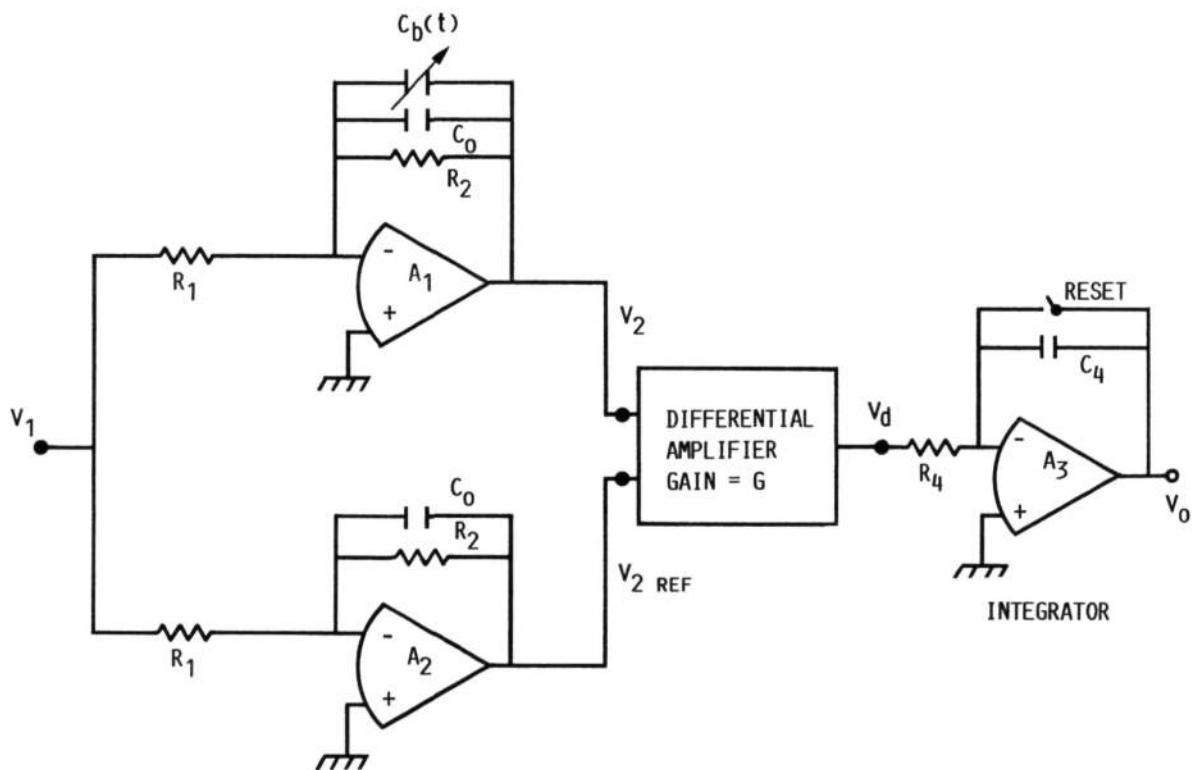

FIGURE 14. - SCHEMATIC SHOWING REFERENCE CHANNEL, DIFFERENTIAL AMPLIFIER, AND INTEGRATOR.

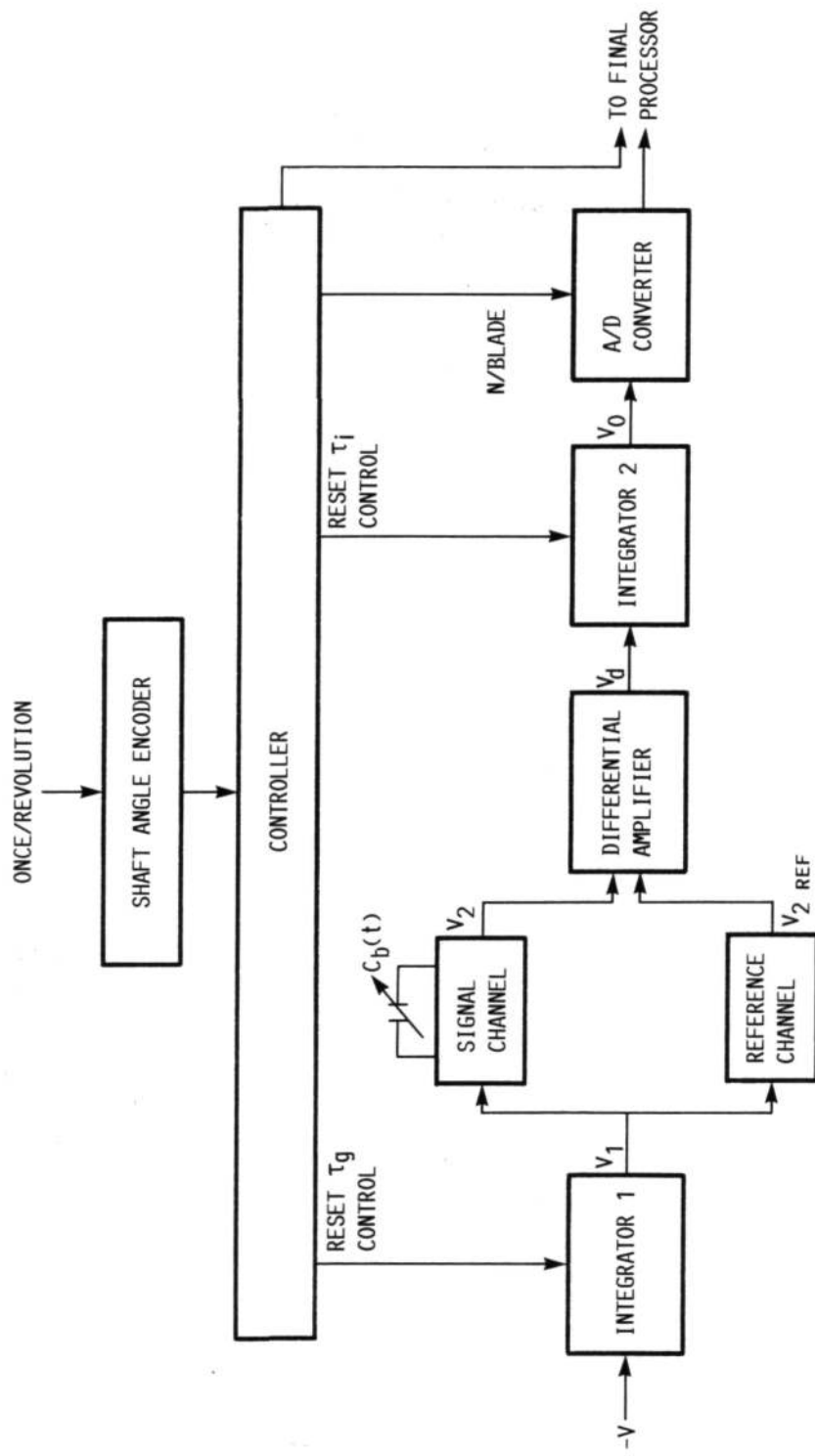

FIGURE 15. - BLOCK DIAGRAM OF PROPOSED RAMP-INTEGRATION BLADE TIP CLEARANCE MEASUREMENT SYSTEM.

ORIGINAL PAGE IS
OF POOR QUALITY

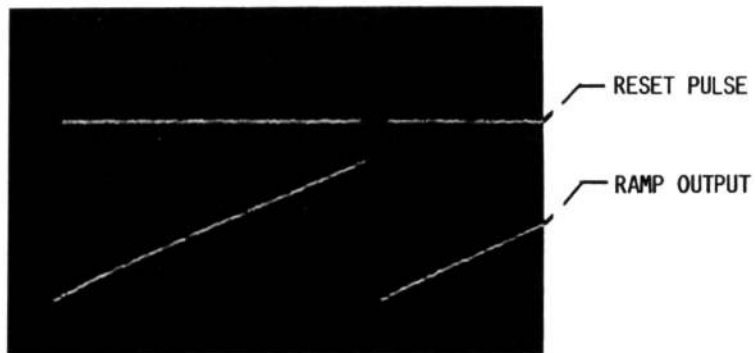

FIGURE 16. - INTEGRATOR RESET SIGNALS FOR ANALOG DEVICES
HOS-050 VIDEO OPERATIONAL AMPLIFIER AND TYPE 4066
SWITCH. (VERTICAL SCALE, 5 V/DIVISION; HORIZONTAL
SCALE, 2 μ SEC/DIVISION.)

1. Report No. NASA TM-101291		2. Government Accession No.		3. Recipient's Catalog No.	
4. Title and Subtitle Recent Advances in Capacitance Type of Blade Tip Clearance Measurements				5. Report Date	
				6. Performing Organization Code	
7. Author(s) John P. Barranger				8. Performing Organization Report No. E-4271	
				10. Work Unit No. 505-62-01	
9. Performing Organization Name and Address National Aeronautics and Space Administration Lewis Research Center Cleveland, Ohio 44135-3191				11. Contract or Grant No.	
				13. Type of Report and Period Covered Technical Memorandum	
12. Sponsoring Agency Name and Address National Aeronautics and Space Administration Washington, D.C. 20546-0001				14. Sponsoring Agency Code	
15. Supplementary Notes Prepared for the Conference on Sensors and Measurement Techniques for Aeronautical Applications, sponsored by the American Institute of Aeronautics and Astronautics, Atlanta, Georgia, September 7-9, 1988.					
16. Abstract Two recent electronic advances at the NASA Lewis Research Center that meet the blade tip clearance needs of a wide class of fans, compressors, and turbines are described. The first is a frequency modulated (FM) oscillator that requires only a single low-cost ultra-high-frequency operational amplifier. Its carrier frequency is 42.8 MHz when used with a 61-cm (24-in.) long hermetically sealed coaxial cable. The oscillator can be calibrated in the static mode and has a negative peak frequency deviation of 400 kHz for a typical rotor blade. High temperature performance tests of the probe and 13 cm (5 in.) of the adjacent cable show good accuracy up to 600 °C (1110 °F), the maximum permissible probe seal temperature. The major source of error is the residual FM oscillator noise, which produces a clearance error of $\pm 10 \mu\text{m}$ (0.4 mil) at a clearance of 500 μm (20 mils). In the second advance, a guarded probe configuration allows a longer cable length (6 meters (20 ft.)) and provides immunity to environmentally induced changes in cable capacitance. The capacitance of the probe is part of a small time constant feedback in a high speed operational amplifier. The solution of the governing differential equation is applied to a ramp type of input. The results show an amplifier output that contains a term which is proportional to the derivative of the feedback capacitance. The capacitance is obtained by subtracting a balancing reference channel followed by an integration stage. Unlike some other capacitance feedback techniques, this ramp-integration method has static calibration capability.					
17. Key Words (Suggested by Author(s)) Turbomachinery Blade tip clearance Instrumentation Measurements				18. Distribution Statement Classified - Unlimited Subject Category 07	
19. Security Classif. (of this report) Unclassified		20. Security Classif. (of this page) Unclassified		21. No of pages 16	22. Price* A02

BLADE TIPS
CLEARANCES
TURBINE BLADES
CAPACITANCE
ELECTRICAL MEASUREMENTS

TURBOMACHINE
FREQUENCY MODULATION
CARRIER FREQUENCY
OSCILLATOR
COAXIAL CABLES
CALIBRATION

National Aeronautics and
Space Administration

Lewis Research Center
Cleveland, Ohio 44135

Official Business
Penalty for Private Use \$300

FOURTH CLASS MAIL

ADDRESS CORRECTION REQUESTED



Postage and Fees Paid
National Aeronautics and
Space Administration
NASA-451

NASA
