

# Recent Development on Electric Vehicles

K.W.E CHENG<sup>1</sup>

<sup>1</sup>Department of Electrical Engineering, The Hong Kong Polytechnic University, Hong Kong  
Email: eeecheng@polyu.edu.hk

**Abstract** – This paper provide an overview of the recent work of electric vehicle in the region. The paper describes the development and the comparison of different part of components. The major components in battery technology, charger design, motor, steering and braking are examined. The paper finally shows some electric vehicle prototype as a conclusion of the papers.

**Keywords** – Electric vehicle, AFS, steering system, braking system, ABS, battery management systems, BMS, Inverter

## I. INTRODUCTION

Electrical vehicle (EV) based on electric propulsion system. No internal combustion engine is used. All the power is based on electric power as the energy source. The main advantage is the high efficiency in power conversion through its proposition system of electric motor. Recently there has been massive research and development work reported in both academic and industry. Commercial vehicle is also available. Many countries have provided incentive to users through lower tax or tax exemption, free parking and free charging facilities. On the other hand, the hybrid electric vehicle (HEV) is an alterative. It has been used extensive in the last few years. Nearly all the car manufacturers have at least one model in hybrid electric vehicle. The questions come to us: Which vehicle will dominate the market and which one is suitable for future? This paper is to examine the recent development of electric vehicle and suggest the future development in the area.

## II. EV AND HEV

HEV has been promoted extensively in the last decade. Nearly each manufacturer has at least one HEV in the market [1]. It is supposed to rescue the battery energy storage problem at that time. Using hybrid vehicle it allows the electric power can be obtained from engine. The HEV is broadly divided into series hybrid and series hybrid. The engine power of the series hybrid is connected totally to the battery. All the motor power is derived from the battery. For the parallel hybrid, both the engine and motor contribute the propulsion power. The torque is the sum of both motor and engine. The motor is also used as a generator to absorb the power from engine through the transmission. Bothe series or hybrid can absorb power through regeneration during braking or deceleration.

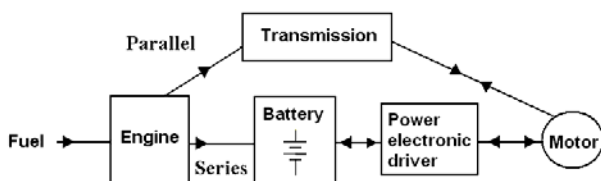

Fig 1: The series or parallel path of an HEV

Nevertheless, HEV still has emission. The introduction of plug-in HEV that solves some of the problem [2]. It accepts the electric power to battery through plug in from the mains. Therefore when convenient, users may charge the battery using AC from the mains.

## III. THE KEY COMPONENTS IN EV

The electric vehicle is rather simple in structure. The key components are the propulsion parts. Fig 2 shows the configuration.

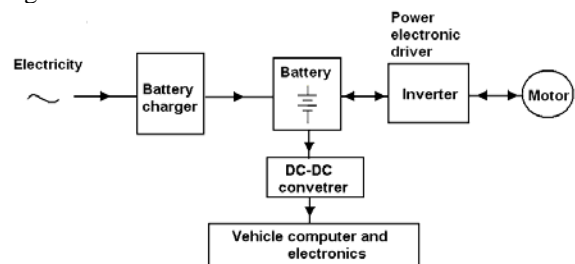

Fig 2: The key components of an Electric Vehicle.

The battery is the main energy storage. The battery charger is to convert the electricity from mains to charge the battery [3]. The battery voltage is DC and I is inverted into switched-mode signal through power electronic inverter to drive the motor. The other electronic components in a vehicle can be supplied to the battery through DC-DC converter that step down the voltage from the battery pack to lower voltage such as 5V-20V.

## IV. THE MOTOR

There are a number of motors available for electric vehicle: DC motors, Induction motor, DC brushless motor, Permanent magnetic synchronous motor and Switched reluctance motor.

### 1. DC motors:

It is a classical motor and has been used in motor control for a long time. All the power involved in electromechanical conversion is transferred to the rotor through stationary brushes which are in rubbing contact with the copper segments of the commutator. It requires certain maintenance and has a shorter life time. However, it is suitable for low power application. It has found applications in electric wheel-chair, transporter and micro-car. Today, most of the golf-carts are using DC motors. The power level is less than 4kW.

### 2. Induction motor

It is a very popular AC motors [4]. It also has a large market share in variable speed drive application such as air-conditioning, elevator or escalator. Many of the higher power electric vehicles, for more than 5kW, uses

induction motor. Usually a vector drive is used to provide torque and speed control.

3. DC brushless motor

The conventional DC motor is poor mechanically because the low power winding, the field, is stationary while the main high power winding rotates. The DC brushless motor is "turned inside out [5]-[6]. The high power winding is put on the stationary side of the motor and the field excitation is on the rotor using a permanent magnet. The motor has longer life time than the DC motor but is a few times more expensive. Most of the DC motor can be replaced by the brushless motor with suitable driver. Presently, its applications find in low power EV.

4. Permanent magnetic synchronous motor

The stator is similar to that of an induction motor. The rotor is mounted with permanent magnets. It is equivalent to an induction motor but the air-gap field is produced by a permanent magnet. The driving voltage is sinewave generated by Pulse Width Modulation (PWM).

5. Switched reluctance motor

It is a variable reluctance machine and its famous recently because of the fault tolerance because each phase is decoupled from other. The power stage is different from other the motor discussed in 2-4. Each phase winding is connected in a flyback circuit style [7].

IV DIRECT DRIVE AND IN-WHEEL MOTOR

Direct drive reduces the loss in the mechanical units of the drive train. The motor is connected directly to the shaft to reduce needs of transmission, clutch, and gear box. Recently the in-wheel motor is promoted by researcher [8]. The in-wheel motor is to turn the rotor inside out and attached to the wheel's rim and the tire. There is no gear box and drive shaft. Fig 3 shows the in-wheel motor.



a) Hardware b) FEM model

Fig 3: The in-wheel motor

The motor is also called wheel-hub motor. Its main advantage is the independent control of each wheel. Fig 4 shows the 4-wheeler drive vehicle. Each of the wheels works any speed and direction. Therefore the parallel parking can be achieved easily. The Anti-lock braking system can be implemented easily by the technology. It has been shown that it can successfully prevent spinout. The whole vehicle is much simpler in structure. Many different types of motor can be used for in-wheel motor. The prominent one is the switched-reluctance types. Its phase-winding is independently from each and therefore the fault tolerance is much more advanced than the other. There is no permanent magnetic in the motor, it reduces any interference by permanent field and the fluctuation of the permanent magnetic materials.

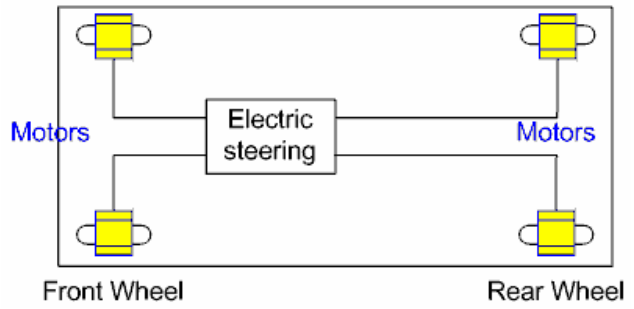

Fig. 4: True 4-wheel drive vehicle.

V ENERGY STORAGE

1. Batteries

The battery is the main energy storage in the electric vehicle. The battery in-fact governs the success of the electric vehicle [9]. Recently there are massive works being reported in battery development. The battery such as Li-ion is now being used by new generation of electric vehicle. The danger of the instability of the battery has been studied by many reported. It seems that the LiFePO<sub>4</sub> type is preferable because of its chemically stable and inherently safe. Other Li-ion such as LiCoO<sub>2</sub>, LiMn<sub>2</sub>O<sub>4</sub> and Li(Ni<sub>1/3</sub>Mn<sub>1/3</sub>Co<sub>1/3</sub>)O<sub>2</sub> may have the thermal and overcharge concern [10]. For low cost solution, the lead-acid battery is still dominant part of the market. The battery has found applications in electric wheel chair, Golf-cart, micro-car and neighborhood town air. The recent RoHS has also stopped the use of NiCd battery.

All the research is looking towards the fast charging for batteries. MIT reported [11] the technology of a crystal structure that allows 100 times of charging speed than conventional Li-ion battery. Other alternative is to use ultra-capacitor.

2. Ultra-capacitor

Capacitor is basically a static component. There is no chemical reaction in the components. Its charging and discharging speeds are very fast. However, the energy storage is limited. Its energy storage density is less than 20% of the lead-acid battery. Although the expected ultra-capacitor density will go up in next few years, its total solution for main energy storage is a challenge. The number of cycles and the temperature range is excellent. Table 1 shows the comparison.

Table 1: Comparison of different energy storage unit

	Lead-acid	NiMH	Li-ion	Ultra-capacitor
Energy density Whr/kg	40	70	110	5
Cycle life	500	8,00	1,000	500,000
Working temperature(°C)	-30 ~ +50	-40 ~ +50	-40 ~ +60	-40 ~ +85
Cost \$/kWhr	1,000	2,400	5,000	50,000

Therefore ultra-capacitor is useful for fast speed or transient energy storage. As it allows high current charging, its charging time can be shortened to within a few minutes.

The ultra-capacitor is still in the initial stage of development. It is expected that the cost will be going down and the energy density will go up rapidly in next few years.

VI. CHARGING SYSTEMS

1. General charger

The charger needed for the battery system for slow charging or fast charger are both required to handle high power. The H-bridge power converter is needed [12]. Fig 5 shows the converter. The converter is famous for its efficiency and has found application in charger and DC-DC converter.

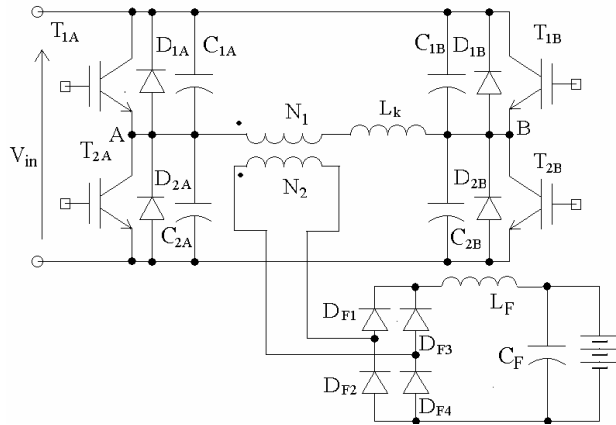

Fig 5: The H-bridge converter for charger

2. Ultra-capacitor charger

The voltage on the ultra-capacitor varies from the full-voltage to zero when its energy storage varies from full to zero. This is different from the battery as its voltage will only vary within 25%. The capacitor voltage is internal point and is not in contact with users. The transformer isolated converter is not necessary. A tapped converter should be used as it will have higher efficiency for power conversion [13]. The efficiency of the power converter is higher than the transformer-isolated version. The structure is simple.

3. Battery management systems

It is also referred as BMS. The battery system is formed by a number of battery cells. They are connected in parallel or series that is according to the design. Each of the cell should be monitored and regulated. The conditioning monitoring includes the voltage, current and temperature. The measured parameters are used to provide the decision parameter for the system control and protection.

Two parameters are usually provided. They are the state of charge (SoC) and the State of Health (SoH). SoC is like the oil tank meter that provides the battery charging condition. It is measured by the information of voltage and current. The SoH is to record the health or aging condition. There are a few definitions but the prominent one is :

$$SoH = \frac{\text{Nominal Capacity} - \text{Loss of Capacity}}{\text{Nominal Capacity}} \quad (1)$$

Cell balancing is to ensure each cell is operating under the same conditioning or a regulation is used to charge or discharge each cell by the balancing control. This avoids the overload of a particular cell.

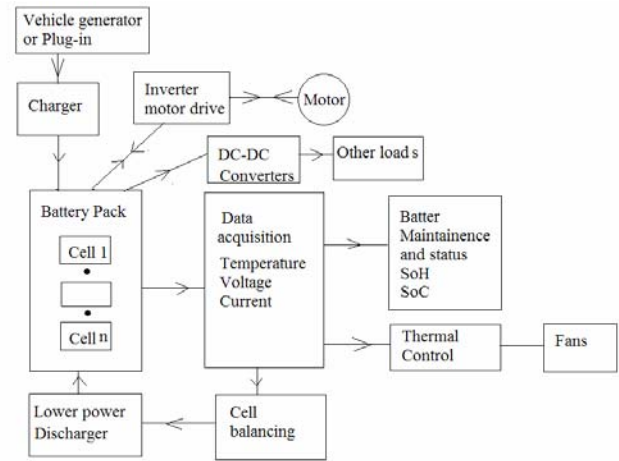

Fig 6: Schematic of the BMS

4. Energy management systems

Even for ultra-capacitor system, the energy storage is made by a number of capacitors or in a combination with other energy storage devices such as battery. The same conditioning monitoring and management system will be used.

VII. CHARGING NETWORK

1. Charging network

The charging method of EV is controversial because of the uncertainty of the power needed, location and the charging time. The charging time of batteries has been reported to be shorter in the recent development. The lead-acid batteries are restricted by its technology. The charging rate is less than 0.2C and quicker charging rate seriously shortens its life time. Other battery such as Li-ion has recommended charging rate of 0.5C.

Usually most of the electric vehicles have an on-board battery charger. A power cable is connected from the vehicle to a charging point. A charging station should provide a number of power points and a suitable transaction program to calculate the tariff.

The power needed for the charging station is not a concern. Usually for private car, a standard charging power is less than 2.8kW. Single-phase power line is used. In average a vehicle is needed to be charged every 3 days. Using Hong Kong as an example, it will only affect the power consumption of less than 2% even all the private cars are charged to EV.

2. Fast charging station

For fast charging, a high current is needed, therefore three-phase power is usually used. The charging station should consider the method to connect the 3-phase socket to users as not all the civilian can handle the use of 3-phase socket system. The following has been discussed:

- a. Magnetic contactless charging: There is no metal contact, all the power transfer is through magnetic induction. This reduce the concern when a civilian to handle high power cable and he/she does not need to contact the conductors.
- b. High voltage power transfer: The heavy and large 3-phase socket and cable can be reduced in size by

high voltage connection. The power source is stepped up to high voltage of several kV, and the cable is reduced. There is another step-down converter in the vehicle that reduced the high voltage to suitable lower voltage to charge the battery.

- c. Battery rental: This has been suggested from the 1<sup>st</sup> day of the promotion of EV. All the batteries are not owned by the users but on a rental arrangement. Users go to charging station to swap the batteries to fully-charged ones. The time needed is just a few minutes. The design of the EV should be made for such changes. The vehicle battery charging in the station can also be used for energy storage to ease peak demand through valley supply compensation.

VIII. BRAKING AND STEERING

1. Braking and power regeneration

The braking of a vehicle in the past based on mechanical system such as disc brake. The braking method of an EV should be integrated with both mechanical and the electrical braking. In the initial region of the braking pedal, it electrical power regeneration braking should be applied. This is usually for deceleration or going down a slope, the kinetic energy of the vehicle can be returned to the battery. The final region of the braking, mechanical braking is used. This provides a compromise of the energy saving and safety.

Today, we can make motors with high power of regeneration that is in the expenses of the motor size, a compromise between the motor weight, cost, power regeneration efficiency and safety are needed. To increase the region of the power regeneration, the motor should be made with acceptance of the high power design plugging mode which is to provide high reverse torque to stop the vehicle. The motor drive should also be implemented with high frequency decoupling capacitor to absorb the fast transient of the reverse current.

2. Anti-lock braking (ABS)

Conventional ABS is installed in most of the vehicle to prevent skidding and to obtain a stable braking performance. The braking characteristic depends on the wheel slip as well as the road condition [14]. It combines continuous slip changing and discrete valve action which induces discrete hydraulic pressure, PID and finite state machine theory are applied to the anti-lock braking system.

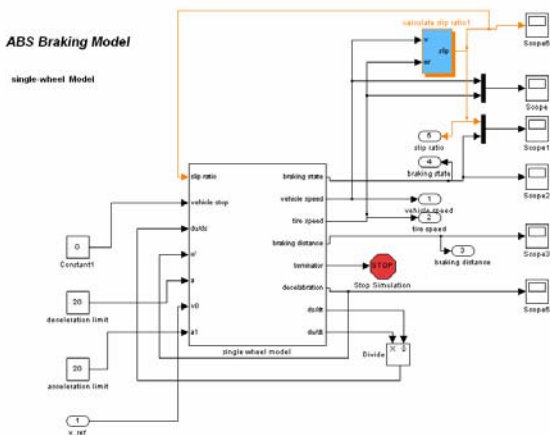

Fig 6: ABS braking system model

The ABS optimization consists to maximize the tire forces whatever the conditions of the road. Therefore, it must to localize the wheel slip ratio which corresponds to the peak tire road adhesion characteristic. The location and the value of these peak values varies in large range depending on the road, tire and many other different factors, For any rolling conditions, the optimal wheel slip rate, which will be used as control reference to optimize the braking force. Fig 6 shows a scheme of ABS based on all electrical motor drive system.

3. Skid Steering

Steering is achieved by differentially varying the speeds of the lines of wheels on different sides of the vehicle in order to induce yaw. To satisfy the requirement of the turn radius, the longitudinal slip must be controlled, so a method of slip limitation feedback is used in the simulation. When the vehicle is turning on a slippery surface, because of the drop at the coefficient of road adhesion, the drive wheels may slip. The traction control system reduces the engine torque and brings the slipping wheels into the desirable skid range. Fig 7 shows the locus of skid steering for different turn radius.

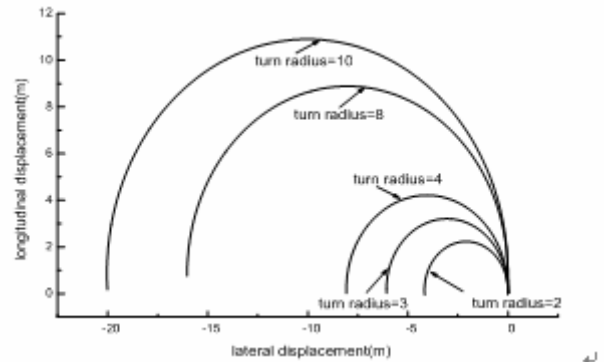

Fig 7: Locus of different turn radius achieved by skid steering

IX. SUSPENSION

The developed direct-drive linear motor actuator for the automobile active suspension systems can generate control forces to absorb road shocks rapidly, suppress the roll and pitch motions, and ameliorate both safety and comfort, while maintaining the vehicle at a horizontal level. For conventional passive suspension systems, it is difficult to be achieved, since a soft spring allows for too much movement and a hard spring causes passenger discomfort due to road irregularities. Thus, significant improvement of suspension performance is achieved by the direct-drive linear switched reluctance actuator. Comparing with hydraulic active suspension systems, the developed active suspension system based on the direct-drive linear switched reluctance actuator is simpler since it needs fewer devices and mechanical parts. Due to no hydraulic devices, this is an oil-free system. Furthermore, it can include the energy generation from the suspension. The development includes the design of direct-drive linear switched reluctance actuator, its characterization, and the design of the automobile active suspension system. The converter drive is also needed to develop to match with the linear switched reluctance actuator. The drive is expected to fit the driving pattern of the suspension system and to provide suitable force control, energy generation control and position control. Fig 8 shows a prototype design of an active suspension system.

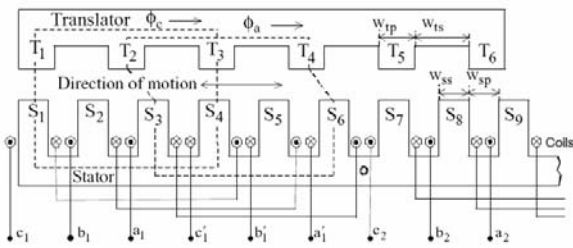

Fig 8: Active suspension based on linear motor.

X. OTHER ACCESSORIES

The front lighting system based on LED and Adaptive front-lighting systems (AFS) is a vital security lighting system in vehicles. An AFS functionality is divided into three parts, one is the headlamp leveling subsystems, which work to keep light parallel to the road surface when the vehicle's tilt state changes in dynamic and static mode; the another one is swiveling subsystem, which matches the light distribution with the vehicle's turning angle so as to produce the best illumination effect for driver. The last one is dimming system, which fade or dim up illumination along with the ambient light and lane environment changes. Fig 9 shows a sample of an LED front-light.



Fig 9: AN LED front-lighting unit.

XI. ELECTRIC VEHICLE SHOW CASES

Recently there are a number of local and overseas companies and institutions have been working on electric vehicle. The development on electronic parts and accessories from propulsion, safety and control has been reported. A local university has recently reported their EV development. Fig 9 shows the private car, security car, micro-car and motorcycle.



Fig 9: Electric vehicles developed

XII. CONCLUSION

This paper discusses the recent development in electric vehicle. The paper first describes general structure and

discusses the energy storage. It then extends to the future vehicle components. The paper provides an overview of the recent EV work in the region

ACKNOWLEDGMENT

The author acknowledges the support of Hong Kong Polytechnic University and the Power Electronics Research Centre for the EV work.

REFERENCES

- [1] Jones, W.D., "Hybrids to the rescue [hybrid electric vehicles]", IEEE Spectrum, Vol. 40(1), 2003, pp. 70 – 71.
- [2] Jones, W.D., "Take this car and plug it [plug-in hybrid vehicles]", Spectrum, IEEE, Vol. 42, Issue 7, July 2005, pp. 10 – 13.
- [3] Hyunjae Yoo; Seung-Ki Sul; Yongho Park; Jongchan Jeong, "System Integration and Power-Flow Management for a Series Hybrid Electric Vehicle Using Supercapacitors and Batteries", IEEE Trans. on Industry Applications, Vol. 44, Issue 1, Jan.-Feb. 2008, pp. 108 – 114.
- [4] Haddoun, A.; Benbouzid, M. E. H.; Diallo, D.; Abdessemed, R.; Ghouli, J.; Srairi, K., "A Loss-Minimization DTC Scheme for EV Induction Motors", IEEE Trans on Vehicular Technology, Vol. 56(1), Jan. 2007, pp. 81 – 88.
- [5] Jinyun Gan; Chau, K.T.; Chan, C.C.; Jiang, J.Z., "A new surface-inset, permanent-magnet, brushless DC motor drive for electric vehicles", IEEE Transactions on Magnetics, Vol. 36, Issue 5, Part 2, Sept 2000, pp. 3810 – 3818.
- [6] Chau, K.T.; Chan, C.C.; Chunhua Liu, "Overview of Permanent-Magnet Brushless Drives for Electric and Hybrid Electric Vehicles", IEEE Trans. on Industrial Electronics, Vol. 55, Issue 6, June 2008, pp. 2246 – 2257.
- [7] Rahman, K.M.; Fahimi, B.; Suresh, G.; Rajarathnam, A.V.; Ehsani, M., "Advantages of switched reluctance motor applications to EV and HEV: design and control issues", IEEE Transactions on Industry Applications, Vol. 36, Issue 1, Jan.-Feb. 2000, pp. 111 – 121.
- [8] Jones, W.D., "Putting Electricity Where The Rubber Meets the Road [NEWS]", IEEE Spectrum, Vol. 44, Issue 7, July 2007, pp. 18 – 20.
- [9] Affanni, A.; Bellini, A.; Franceschini, G.; Guglielmi, P.; Tassoni, C., "Battery choice and management for new-generation electric vehicles", IEEE Trans. on Industrial Electronics, Vol. 52(5), Oct. 2005, pp. 1343 – 1349.
- [10] Chan, C.C. The Present Status and Future Trends of Electric vehicles, Science and Technology Review, Vol. 23, No. 4, Feb 2005
- [11] Andrew Williams, "MIT Battery Breakthrough Could Revolutionize Electric Cars", March 12th, 2009 in Batteries, Electric Cars (EVs), <http://gas2.org/2009/03/12/mit-battery-breakthrough-could-revolutionize-electric-cars/>
- [12] Y.Lu, Cheng K.W.E., S.L.Ho, J F Pan, "Passivity-Based Control of Phase Shifted Resonant Converter", IEEE Proc. Elect. Power Appl., Vol. 152(6), Nov. 2005, pp.1509 – 1515
- [13] K.W.E.Cheng, "Tapped inductor for switched-mode power converters", 2<sup>nd</sup> Int. Conference on Power Electronics Systems and Applications, 2006, pp. 14-20.
- [14] Chikhi, F. El Hadri, A. Cadiou, J.C. " ABS control design based on wheel-slip peak localization". Proceedings of the Fifth International Workshop on Robot Motion and Control, Publication Date: 23-25 June 2005, pp.73- 77