

Recent developments in optical detection methods for microchip separations

Sebastian Götz · Uwe Karst

Received: 7 July 2006 / Revised: 18 August 2006 / Accepted: 31 August 2006 / Published online: 10 October 2006
© Springer-Verlag 2006

Abstract This paper summarizes the features and performances of optical detection systems currently applied in order to monitor separations on microchip devices. Fluorescence detection, which delivers very high sensitivity and selectivity, is still the most widely applied method of detection. Instruments utilizing laser-induced fluorescence (LIF) and lamp-based fluorescence along with recent applications of light-emitting diodes (LED) as excitation sources are also covered in this paper. Since chemiluminescence detection can be achieved using extremely simple devices which no longer require light sources and optical components for focusing and collimation, interesting approaches based on this technique are presented, too. Although UV/vis absorbance is a detection method that is commonly used in standard desktop electrophoresis and liquid chromatography instruments, it has not yet reached the same level of popularity for microchip applications. Current applications of UV/vis absorbance detection to microchip separations and innovative approaches that increase sensitivity are described. This article, which contains 85 references, focuses on developments and applications published within the last three years, points out exciting new approaches, and provides future perspectives on this field.

Keywords Optical detection methods · Microchip · Microfluidic · Separation · Review

Introduction

Microchip devices that follow the μ -TAS (micro total analysis system) approach have rapidly increased in complexity in recent years [1, 2]. The possibility of manipulating smaller and smaller amounts of sample volume combined with push towards faster separations has placed great demands on the corresponding detection systems. Researchers in this field are driven by the need to develop ultrasensitive detectors for fast separations, which deliver as much information about the analyte as possible.

This review focuses on recent achievements in optical detection techniques used for microfluidic devices and focuses on the more dynamic instruments that are adapted to the detection of rapid separations, in contrast to static detection methods.

Fluorescence detection still is the most widely used optical method for microchip analysis, due to its superior selectivity and sensitivity. Although a variety of excitation sources are available, laser-induced fluorescence (LIF) is most easily adapted to the dimensions of microchips. The coherence and low divergence of a laser beam makes it easy to focus on very small detection volumes and to obtain very high irradiation, resulting in one of the lowest limits of detection of any detection system. Lamp-based excitation systems represent a less expensive but more flexible alternative in terms of the choice of wavelength. Microscope-based detector set-ups using xenon or mercury lamps are applied to a variety of different analytical problems with impressive results. The recent advances in the development of high-output light-emitting diodes (LED) are reflected in

S. Götz · U. Karst
Chemical Analysis Group and MESA+ Institute
for Nanotechnology, University of Twente,
P.O. Box 217, 7500 AE Enschede, The Netherlands

Present address:

U. Karst (✉)
Institute of Inorganic and Analytical Chemistry,
University of Münster,
Corrensstr. 30,
48149 Münster, Germany
e-mail: uk@uni-muenster.de

the growing number of publications that use this excitation principle. Their small size and low cost of production facilitate the incorporation of LEDs into microfluidic devices. Optical detection without any need for an excitation source or a complicated optical set-up can be accomplished by means of chemiluminescence (CL) measurements. As no additional light source is required, no background light is generated at all. This results in low limits of detection as well as excellent selectivity.

The broader application of UV/vis absorbance measurements to separations on microfluidic devices is generally hindered by the low sensitivity that arises from the use of very short optical pathlengths. However, in recent years there has been growing interest in this technique and further developments aimed at improving the sensitivity.

This article focuses on the optical detection methods mentioned above, presenting current applications and recent developments that have occurred over the last three years. Electrochemical detection has been reviewed extensively by others [3–5] and is therefore, like mass spectrometric detection [6], not subject of this paper. Other more general reviews covering earlier results have been published elsewhere [7–9]. Viskari and Landers present a recent overview of more unconventional and less common detection strategies [10] such as thermal lens, infrared and NMR detection, which are therefore not covered in this review.

Fluorescence

Laser-induced fluorescence detection (LIF)

Along with the miniaturization of separation systems to the microchip format, the separation channels used in them have shrunk to only tens of micrometers in width and height. The extreme reduction in detection volume has resulted in an overall reduction in organic solvent, buffer solution and sample amount used. Laser-induced fluorescence detection (LIF) is one of the most important detection methods used in microchip separations, because it can be adapted best to low concentration/low volume systems.

Recent advances in laser technology have produced stable light sources that cover a rapidly increasing range of wavelengths from the ultraviolet to the infrared region of the electromagnetic spectrum, are relatively inexpensive, and can easily be focused onto micron-sized detection areas. The use of a pinhole at the focus point along the optical path (confocal LIF) even allows for three-dimensional focusing and further reduction of the background signal (scattered light, autofluorescence of microchip material). These very low levels of background signal combined with very sensitive photon detection techniques photomultiplier tubes (PMTs), photon counting systems,

charge-coupled devices (CCD) result in the lowest limits of detection of all microchip detection systems.

The fact that only a few compounds exhibit native fluorescence is another reason for the low background signals in LIF, especially in comparison with absorption spectroscopy. On the other hand, labeling with fluorescent markers is required for all non-fluorescent analytes.

Although commercial instruments that can be used for microchip LIF (such as the Agilent Bioanalyzer 2100 system) are available, most researchers depend on homemade LIF detection systems. The Agilent set-up is specialized to RNA/DNA and protein–SDS assays. It has been used for the determination of half-antibody species in immunoglobulin G4 (IgG4) [11, 12] and the detection of the *Alicyclobacillus acidoterrestris* bacterium in orange juice [13]. The instrument enables bioassays to be performed on primed microchips, and gives limits of detection in the lower μg per ml range. The overall package, consisting of sample preparation kit, microchip, detector and adapted software, is well-suited for a range of routine analyses but lacks the flexibility and modularity usually required in research set-ups. Hence, the vast majority of laboratory systems are homemade. They usually consist of the following basic parts: a laser excitation source, an optical system to focus and collect the light, and a photosensitive detector, generally a photomultiplier tube (PMT).

Two main optical system designs can be found. The first one (Fig. 1a) uses a lens or an objective to focus the laser onto the microchip channel, typically at an angle of 45° or 37° (Brewster's angle), while the collimation of emission light is performed by an objective perpendicular to the chip plane [14–17]. The second approach (Fig. 1b) uses the same objective to focus and collect the light, and a dichroic mirror for wavelength separation [18–25]. For fast operation and fast optical alignment, all of the optical components of those (epifluorescence) systems are often incorporated into a fluorescence microscope [26–30]. A pinhole is commonly placed at the focal point along the light path to get spatial filtering of the emission and to reduce scattered and background light. The diameters of those pinholes range from $40\ \mu\text{m}$ to 2 mm.

Lin et al. used a homemade set-up comprising a 20 mW laser diode pumped solid-state laser (532 nm), epifluorescence optics with a $400\ \mu\text{m}$ pinhole, and a PMT for bioanalysis. They determined the tumor-associated methylated p16 gene [31] and SARS and hepatitis B virus infections [32] via the analysis of multiplex PCR fragments. Their system had a limit of detection for rhodamine 6G of 6.7×10^{-13} mol/L, with a dynamic range of three decades. A 603 bp DNA fragment could be detected at a concentration of $0.2\ \text{ng}/\mu\text{L}$, showing a 40-fold increase in sensitivity compared to slab-gel electrophoresis.

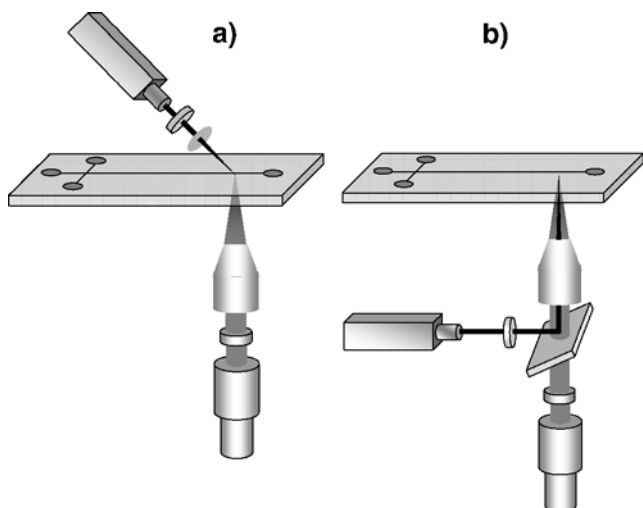

Fig. 1 **a** Common set-up used for the LIF detection system, including laser, excitation filter and focusing lens; emission is collimated by an objective followed by an emission filter and a PMT detector. **b** Epifluorescence set-up, including wavelength-dependent (dichroic) beam splitter

The PMT has become the most widely used detector in LIF; it gives excellent sensitivity, a wide dynamic range and a high detection frequency. With the increasing separation speed obtained on microchips, peak widths are growing smaller and smaller. To monitor separations with peak widths below 500 ms, the very high detection frequency provided by photomultiplier tubes is needed.

Liu and coworkers used LIF with PMT detection for sub-second separation of three flavin metabolites [33]. Fluorescent labeling was not needed due to the native fluorescence of riboflavin, and flavin mononucleotide and flavin adenine dinucleotide could be detected down to mid-nanomolar concentrations. Qin et al. separated flavin metabolites and developed a very interesting information-rich detector set-up [34]. They used a pulsed nitrogen laser pumping different dye solutions to obtain a tunable laser excitation.

Fluorescence emission was guided to a spectrometer including an intensified CCD detector. This set-up potentially facilitates wavelength-resolved detection comparable to diode-array detection in UV/vis absorbance measurements. Preliminary results show that under static conditions flavin metabolites can be detected in the lower micromolar range, but on-line emission spectra or peak purity plots of dynamic separations have not yet been presented.

Flavin metabolites are a rare example of an analyte that possesses native fluorescent properties and can be excited in the visible area of the electromagnetic spectrum. They have therefore been frequently used as model analytes for LIF detection.

However, if excited with UV light, a large number of biological compounds are fluorescent, especially proteins containing tryptophan or tyrosine. However, the ability to

exploit these useful native properties is hindered by the fact that optical components are commonly made of glass, which makes them nontransparent to light with a wavelength of below 330 nm. Belder et al. built a compact device combining UV filters, a 275 nm dichroic mirror and a UV-transparent microscope objective [35]. Fiber-coupled to a 266 nm frequency-quadrupled Nd:YAG laser, this cube can be mounted onto the objective holder of a commercially available fluorescence microscope. Bearing in mind that all of the components in the lightpath have to be UV-transparent, electrophoretic separations were performed on fused-silica microchips. It was possible to detect the separation of proteins with native fluorescence down to a concentration of 12.5 $\mu\text{g/mL}$ (0.9, 0.5 and 0.5 μM for lysozyme, trypsinogen and chymotrypsinogen).

Incorporating optical fibers into the microchip is one approach used to simplify the detection system by minimizing the number of required optical components. Lin and coworkers etched an additional channel into the microchip, into which they introduced an optical fiber coupled to a blue diode-pumped laser (Fig. 2) [36, 37]. This channel ended 190 μm away from the separation channel and enabled excitation without the need for any focusing optical components. Beneath the chip they attached a 400 μm pinhole, a holographic notch filter (476 nm) and an interference filter (535 nm). The emission light was then detected directly with a PMT from below the chip without any collimating optics. Fluorescein isothiocyanate (FITC)-labeled epinephrine and dopamine could be detected in the concentration range from 2×10^{-4} mol/L to 1×10^{-7} mol/L with a linear response.

A dual-wavelength detection approach using integrated optical fibers was presented by Lee et al. [38]. They fabricated a glass/PDMS hybrid chip with two sets of integrated optical fibers facing each other (Fig. 3). Each of the two channels was excited by a separate laser source, enabling two different wavelengths to be produced (488 and 632.8 nm). The two optical fibers were connected to two PMT modules equipped with appropriate band-pass filters to exclude excitation light. Although no separation

Fig. 2 Microchip with integrated optical fiber used for laser excitation

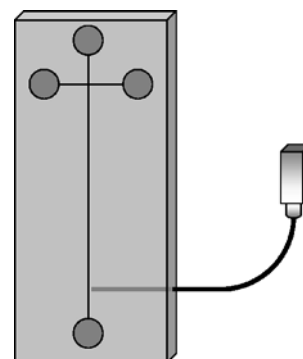

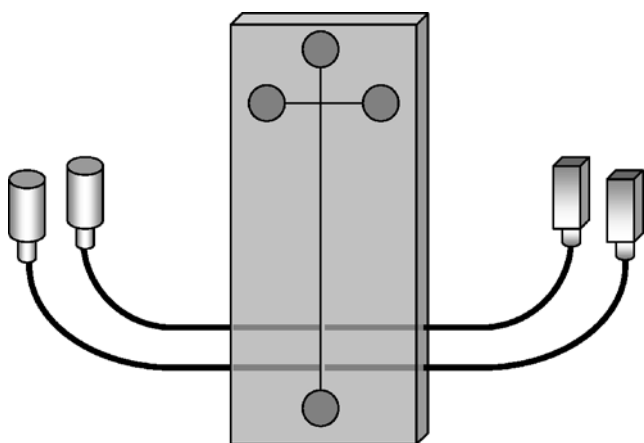

Fig. 3 Microchip with two sets of integrated optical fibers for laser-induced fluorescence with two-channel PMT detection

was performed, a protein sample plug (BSA) labeled with two different fluorescent dyes (FITC and Cy5) could be observed with the two-wavelength detection set-up. Limits of detection of 200 ppm for labeled BSA are claimed.

An interesting way of reducing the background signal caused by scattered excitation light is presented by Fang et al. [39]. They use a LIF detection system based on an orthogonal optical arrangement. Using an excitation beam perpendicular to the chip, highly sensitive detection was achieved by collimating the emission light from the microchannel through the sidewall of the chip (Fig. 4). A special microchip layout was used to bring the separation channel in close proximity with the sidewall (1.5 mm), which was intensively polished to form a highly transparent surface. The emitted light was collimated with a microscope objective and focused onto a 900 μm pinhole. Two filters excluded the remaining excitation light, while the actual detection was performed by a PMT. The amount of scattered light as well as fluorescence emission was found

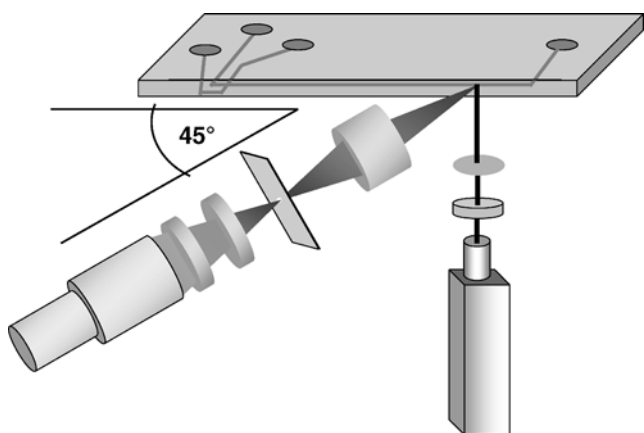

Fig. 4 Orthogonal LIF set-up with collimation of emission light through the sidewall of the chip

to be dependent on the viewing angle in the plane with the chip. Studies of both intensities with regards to the viewing angle revealed the most favorable ratio between the fluorescence signal and the scattered light at a collection angle of 45° , which was then used for further measurements. The limit of detection for fluorescein was 1.1 pM. The performance of the system was further demonstrated by the separation of FITC-labeled amino acids, which could be achieved at a concentration of 100 pM with RSD values of 3.0 and 3.6% obtained for FITC-arginine and FITC-phenylalanine, respectively.

An approach to the simultaneous LIF detection of multiple CE separations was proposed by Lin and co-workers [40]. They developed a microchip with four parallel separation channels, enabling the parallel detection of four different analyte solutions. Using a cylindrical lens to form a laser line, a 20 mW solid-state laser (473 nm) was spread along the chip in order to excite all of the channels at the same time. To conserve the spatial resolution between the different detection points, a CCD camera was used as a detector. Without the need to reprocess recorded video sequences, they developed a software program that directly showed the appropriate electropherograms for each channel on-line. Four different FITC-labeled amino acids could be separated from their labeling reagent.

The initial unsatisfactory repeatability observed when comparing the four channels was improved through the addition of an internal standard to an average of 7.2% RSD, but the use of a 12-bit CCD camera with a grayscale range from 0 to 4096 made the linear detection range very narrow. An application showing the feasibility of the rapid screening of chiral selectors was also presented [41].

The goals of lab-on-a-chip applications include not only the downscaling of the analytical separation system, but the simplification and miniaturization of the detection system as well. Fruetel et al. presented a hand-held CE-LIF device with very impressive abilities [42]. The device utilizes fused silica microchips to perform simultaneous capillary zone and capillary gel electrophoresis with LIF detection. The instrument has a modular design, including a separation platform with a multichannel high-voltage power supply, a battery pack and a control panel equipped with an LCD panel for direct evaluation. The separation platform itself incorporates a microchip (2×3 cm) with two mirrored separation channels, onto which two 392 nm laser diodes are focused. An aperture and a lens pair gave a near-Gaussian beam with ~ 1 mW power delivered to each channel at Brewster's angle (37°). Fluorescence emission was collimated by an aspherical lens and was detected by a PMT after passing a 460 nm long-pass filter. The detection of both channels with one single PMT was achieved by asynchronously pulsing the laser diodes at 10 Hz and using a 50% duty cycle. Software deconvolution separated the

data stream into electropherograms corresponding to each channel. Since it was developed for the detection of biological warfare agents, the device was successfully applied to the separation and detection of fluorescamine-labeled ricin and staphylococcal enterotoxin samples. Additional changes in the design of the instrument, such as the development of a 16-channel high-voltage power supply, a new cartridge-based fluid delivery system, and a redesigned microchip layout (2×2 cm) improved the applicability and stability of the system even further [43]. By providing bidirectional currents of up to 100 μA at 5000 V, the high voltage modules enabled real-time current and voltage monitoring, too. Laser-induced fluorescence detection allowed mid-picomolar (10^{-11} M) sensitivity to fluorescent dyes and low nanomolar sensitivity for fluorescamine-labeled proteins. It was found that the reproducibility of the migration time could be significantly improved when separations were performed under constant current control (0.5–1%) compared to constant voltage control (2–8%).

Lamp-based fluorescence detection

Because lamp-based excitation is the most common method used with fluorescence microscopy to image biological samples, those light sources can be applied very easily to the detection of microchip separations using commercially available microscope set-ups. The common epifluorescence microscope uses condensing optics to collimate and parallelize the light generated by the lamp. After reflection by a dichroic mirror, the light is focused with an objective onto the microscope stage. Fluorescence emission is collected by the same objective and is usually detected by a PMT after encountering a dichroic mirror and an emission filter.

Following LIF detection, lamp-based approaches form the second largest group of optical detection techniques used for microchip separations. Two different light sources can be found. High-pressure xenon arc lamps exhibit a rather homogeneous emission spectrum ranging from the UV up to near-infrared light. Mercury lamps, in contrast, show the typical line spectrum of excited mercury. The line intensity ratios and the underlying background are dependent on the pressure in the applied mercury lamp and can result in a fairly high radiation output at several fixed wavelengths. If, however, the lines do not match the excitation wavelength of the respective analyte, the flexibility of the broad spectrum of the Xe lamp can deliver more favorable results.

Several examples of lamp-based excitation using epifluorescence microscopes combined with PMT detection have been reported [44–47], including the detection of subsecond chiral separation [48] and the fast separation of amino acids in green tea [49]. Chen et al. [50] used this detection method to investigate the potential of flow-

through-based microchip electrophoresis for quantitative analysis, while Heineman and coworkers observed an 160-fold increase in sensitivity when using field-amplified stacking injection for fluorescein derivatives [51].

The highly sensitive instrument developed by Cheng et al. [52] achieved detection limits for FITC-labeled amino acids in the low nanomolar range, comparable to results obtained with laser-induced excitation. The application of a two-channel photon counter behind the preamplifier of the PMT enabled the detection of very weak signals. The limit of detection for FITC was 7×10^{-10} mol/L. The dynamic range of the system, however, was very narrow (1.5 decades) due to saturation effects in the photon counter.

Although PMTs are the most frequently used detectors in this field by far, they cannot be used for applications requiring spatial resolution since they are single-point detectors. In contrast, the two-dimensional chips in charge-coupled devices (CCD) can be sensitive detectors when used for these quantitative imaging purposes. Han and Singh presented the isoelectric focusing of proteins in short microchannels with SDS-PAGE [53]. A fluorescent protein marker sample (molecular mass range 20,000–200,000) was separated in less than 30 s in a channel length shorter than 2 mm. Using an epifluorescence microscope with mercury lamp excitation, the separation was imaged by a CCD camera. Protein concentrations from 10 to 100 $\mu\text{mol/L}$ were observed.

Zhang and Manz [54] used a CCD camera to observe continuous separation in free-flow electrophoresis (FFE). In FFE, an electric field is applied perpendicular to a hydrodynamically driven stream of analytes. Due to different electrophoretic migration speeds, the analyte streams are diverted from their original flow direction at different angles and are thus separated. This set-up has been successfully applied to separate two fluorescent dyes in only 75 ms. The short residence time and small sample flow make the system applicable to the fast monitoring of chemical or biochemical production lines.

A CCD-based approach that uses the camera for spectral rather than spatial resolution was presented by Götz and Karst [55]. A microscope equipped with a xenon lamp was used to observe fluorescence emission spectra during rapid microchip CE separations. The light emitted from the analytes was guided to the entrance slit of a spectrograph, where the light was dispersed. The spectra generated were then projected onto an intensified CCD camera. Three rhodamine dyes with complete on-line fluorescence emission spectra were separated in less than ten seconds. With limits of detection in the mid-nanomolar range, the system delivered information-rich electropherograms comparable to those of diode-array detectors in UV/vis absorbance measurements; it was possible to assign peaks due to spectral properties and to detect hidden coelution via peak

purity plots. The set-up was also successfully applied to the quantitative determination of taurine in beverages [56] and thiols in depilatory cream and cold wave suspensions [57].

Fluorescence excited by light-emitting diodes

Light emitting diodes (LED) have recently been introduced as an inexpensive and powerful alternative light source for fluorescence detection. The new generation of LEDs exhibit very high output power covering the whole visible wavelength range and even UV light. LEDs are the most effective light sources available and require only low-power driving currents. These advantages, combined with their very compact dimensions, mean that they are perfectly suitable for integration into lab-on-a-chip devices.

However, the half-bandwidth of the light emitted from LEDs often exceeds 20 or 30 nm, which implies the need for additional filters and frequently generates a higher level of background signal. Since the photons in a high-output LED are usually generated over an area of a few square millimeters, LEDs are not considered to be point light sources. This fact, combined with the divergence of the emitted light, means that sophisticated collimation and focusing optics are necessary in order to make use of the whole radiation power of the LED.

The commercially available Hitachi SV1100 with a confocal LED detector makes use of a 470 nm LED with a very small radiation area ($250 \times 250 \mu\text{m}$). By using a long-pass notch filter and a non-spherical lens, the LED could be used as an excitation source in a common epifluorescence set-up. The excitation light could be focused down to an area of $120 \times 120 \mu\text{m}$, leading to the general use of microchips with a channel width of $100 \mu\text{m}$. After passing through the dichroic beamsplitter and an emission filter, the emission light is focused by an achromatic lens onto an avalanche photodiode. The Hitachi SV1100 was used by Dang et al. for the rapid analysis of labeled oligosaccharides [58–60] at low micromolar and submicromolar levels. Much faster separation was obtained than achieved using a conventional CE–LIF system. Similar detection limits for glycosaminoglycans and polysaccharides [61] and the analysis of lipoproteins [62] were obtained by other groups.

An approach to LED-induced fluorescence detection with an integrated LED and optical fiber was presented by Uchiyama and coworkers [63]. The distance between the diode and the detection area plays a major role in the divergence of light emitted from LEDs. By separating an LED from its epoxy lens, the authors yielded an LED with a flat surface, which was incorporated into the microchip during fabrication. Although no focusing optics were necessary due to the extreme proximity of the LED, the broad emission spectra of the LEDs used made the introduction of a thin excitation filter necessary (Fig. 5).

An optical fiber was molded into the PDMS chip at right angles to the microchannel.

While a shorter distance to the separation channel would increase the amount of emission light detected, it was found that an unwanted deformation of the channel walls occurred if the optical fiber was placed too close. The optimum distance was found to be $100 \mu\text{m}$. The emission light was guided through the optical fiber through a band-pass emission filter and was detected by a PMT. Limits of detection were significantly improved compared to previous results [64]. For fluorescein and rhodamine dyes, they were found to be in the mid-nanomolar range, but a microscope-based LIF system gave a 20-fold improvement in sensitivity. This is explained by the fact that all of the laser light is easily focused onto the microchannel, while despite its close proximity, only 25% of the emitted light of the LED could be used for detection. Further improvements in sensitivity are anticipated when an LED with a smaller light-emitting face and optimized driving conditions are used.

Luo et al. [65] followed a similar approach, but made use of organic light-emitting diodes (OLED). OLEDs are not frequently used for this purpose because they are not yet commercially available and are still under development. The big advantage of OLEDs compared to LEDs is their flat film-like shape. This makes it easy to incorporate them into microfluidic devices and to bring them into close proximity to the separation channel. However, their fairly broad emission spectra require the additional application of excitation filters. In the work presented, a 0.3 mm-thick interference filter combined with a $400 \mu\text{m}$ pinhole is used to achieve effective excitation with the appropriate wavelength (Fig. 6). Detection of the emission light is accomplished by an optical fiber coupled to a PMT. With this system, a detection limit of $3 \mu\text{mol/L}$ was achieved for

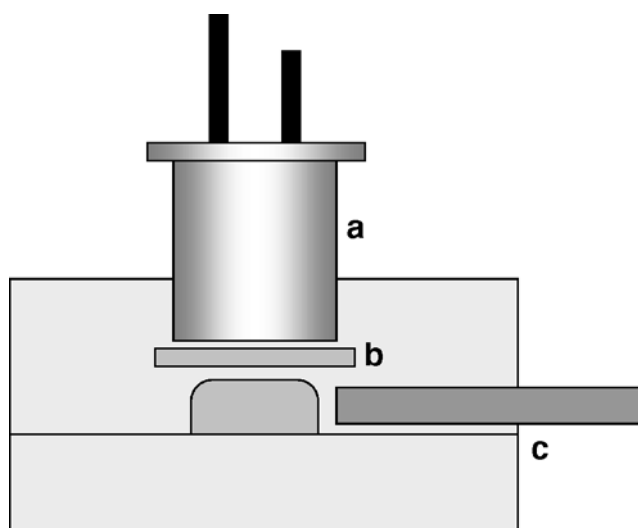

Fig. 5 Cross-section of the microchip with an integrated LED (a) and interference filter (b); emission is collected by the integrated optical fiber (c)

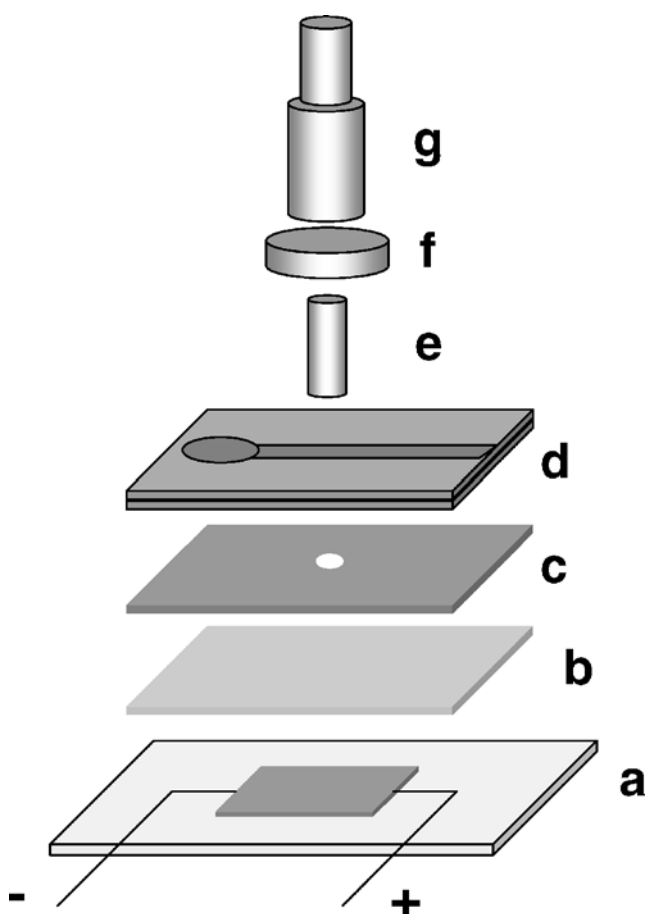

Fig. 6 Schematic design of the microchip with integrated OLED: *a*, OLED on glass substrate; *b*, interference filter; *c*, pinhole; *d*, PDMS/glass microchip; *e*, optical fiber; *f*, emission filter; *g*, PMT detector

the Alexa 532 fluorescent dye. Since this is several orders of magnitude less sensitive than common LIF detection systems, the current drawbacks of OLEDs such as low irradiance and light purity must be solved in order to improve LODs.

(Electro) chemiluminescence detection

Chemiluminescence (CL) has proven to be a very sensitive and selective detection method for common CE separations. Because the light is generated by a chemical reaction, no excitation light source is required and a filter system to reduce the background is not necessary. This simplified set-up is obviously attractive when attempting to integrate chemiluminescence detection onto microchips. However, because the chemiluminescence reagent needs to be mixed with the separated analytes before detection, a more complex microchip layout is required. Liu et al. [66] developed several chip layouts (Fig. 7) and evaluated their performance with respect to different chemiluminescence model systems, including the metal ion-catalyzed luminol–peroxide reaction and the dansyl species-conjugated perox-

alate–peroxide reaction. The separation of Cr(III), Co(II) and Cu(II) ions as well as the chiral recognition of dansyl–phenylalanine enantiomers could be accomplished within one minute with low micromolar and even submicromolar limits of detection. A comparison between the different chip layouts showed that the pattern with the Y-shaped junction (Fig. 7, left) was preferred by the luminol–peroxide system, while a V-shaped junction (Fig. 7, right) yielded better results with the peroxalate–peroxide system. The V-shaped design was later applied to the submicromolar detection of ATP and ATP-conjugated metabolites using a firefly luciferin–luciferase bioluminescence system [67].

While a constant supply of the chemiluminescence reagent is crucial to reproducible detection, it is most frequently delivered by a micropump rather than by electroosmotic flow. Lin et al. used such a system to separate and detect catechol and dopamine [68] as well as dansyl amino acids [69], and obtained limits of detection in the low micromolar range. Huang and Ren [70] developed an extremely simple CL set-up. Without using any optics or filters, the microchip was directly mounted onto a photomultiplier tube. Most of the back of the chip was made opaque through the application of black tape; only a rectangular window (2×3 mm) was uncovered, which served as the detection cell. Using isoelectric focusing, cytochrome *c*, myoglobin and horseradish peroxidase could be separated in less than ten minutes with detection limits of 1.2×10^{-7} , 1.6×10^{-7} and 1.0×10^{-10} mol/L, respectively.

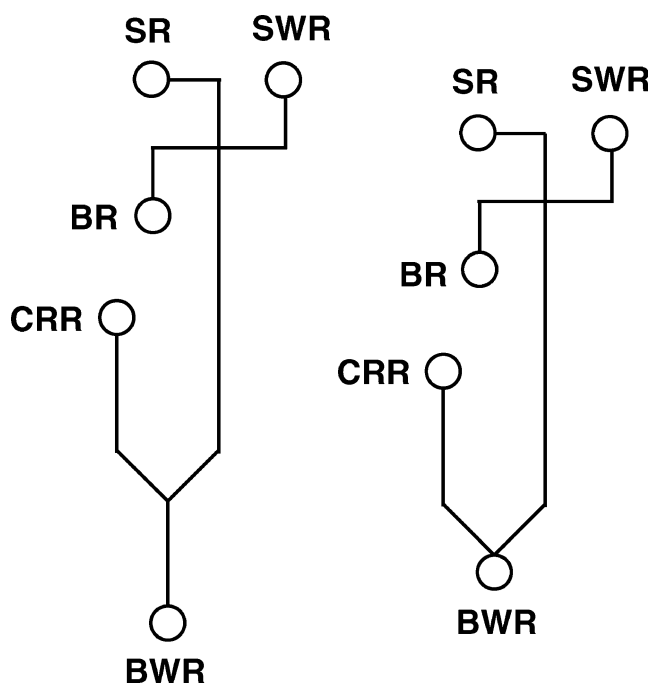

Fig. 7 Different chip layouts used for chemiluminescence detection: *SR*, sample reservoir; *SWR*, sample waste reservoir; *BR*, buffer reservoir; *BWR*, buffer waste reservoir; *CRR*, chemiluminescence reagent reservoir

Wang and coworkers applied an electrochemiluminescence (ECL) detection method to a microchip separation. In ECL, an electroactive compound, in this case tris(2,2'-bipyridyl)ruthenium(II) ($[\text{Ru}(\text{bpy})_3]^{2+}$), is oxidized by applying a voltage to additional electrodes in the separation channel, and it subsequently reacts with the analytes with the emission of photons. In the work presented, thin-film indium tin oxide (ITO) electrodes were added during microchip fabrication [71]. The transparency of the ITO material makes these electrodes superior to the more widely used platinum-based electrodes, because none of the photons generated are absorbed or deflected. The method developed was applied to the detection of proline and the determination of lincomycin in urine down to a concentration of 9 $\mu\text{mol/L}$ [72], while the additional evaluation of the current at the ITO electrodes enabled their simultaneous electrochemical detection due to the catalytic effects of the oxidized $[\text{Ru}(\text{bpy})_3]^{3+}$ [73]. They further simplified their system by immobilizing the ruthenium complex on the ITO electrodes [74]. This approach delivered detection limits similar to the system described earlier, but no addition of the complex to the running buffer was required, which drastically reduced the $[\text{Ru}(\text{bpy})_3]^{2+}$ consumption.

Absorbance detection

UV/vis absorbance detection is the most widely used detection method in common chromatographic and electrophoretic separation systems. However, despite its very wide range of possible applications, only a few examples of absorbance-based detection systems for microfluidic separations can be found. The small dimensions of microchip separation channels pose a severe problem for sensitive and reliable absorbance measurement. The optical pathlength represented by the channel depth is generally shorter than 30 μm .

The presentation of the commercially available Shimadzu MCE system (MCE-2010), equipped with whole-channel UV detection, proved that absorbance measurements were also feasible at microchip dimensions [75–81]. The Shimadzu detection system incorporates a 1.8 kV high-voltage power supply, a deuterium lamp for sample excitation, and a linear diode array (1024 diodes) for a wavelength range of 190–370 nm. In this special design, the diode array is not used to record absorbance spectra after dispersion of the transmitted light, but is rather aligned along the separation channel to perform whole channel detection (Fig. 8). Specially adapted UV-transparent quartz microchips with a separation length of 25 mm are used in this instrument. A narrow optical slit on top of the chip enables the whole channel to be illuminated, and reduces scattered light detected by the linear diode array.

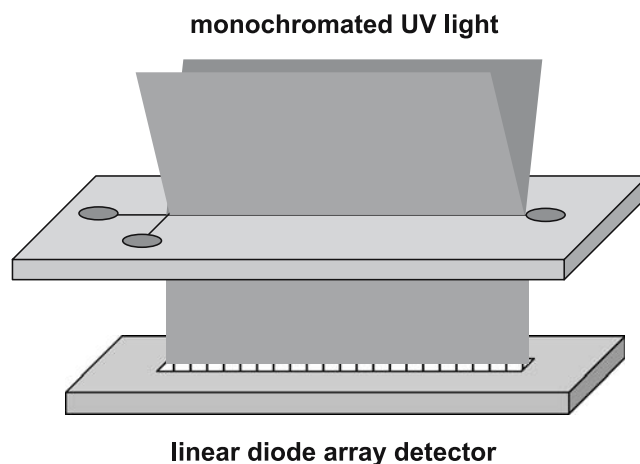

Fig. 8 Whole-channel UV absorbance detection by means of a linear diode array

Guihen and Glennon [82] accomplished a fast separation and determination of antimicrobial metabolites from *Pseudomonas fluorescens* F113 and compared the performance of the MCE separation to a common capillary electrophoretic system. Although speed of the microchip separation (15 s) was much faster than conventional CE separation with a 33 cm capillary (1.9 min), LODs in the low mg/L range were found to be about three times lower than obtained with the common CE set-up.

Belder and coworkers presented fast chiral separation using the Shimadzu MCE-2010 [83]. Nineteen basic drugs could be separated from their enantiomers using several highly sulfated cyclodextrins as chiral selectors. All separations were performed with analyte concentrations of 2 mg/mL, and were generally accomplished within less than one minute. These limits of detection show that the Shimadzu detector is not designed for trace analysis but its interesting whole-channel detection design allows rapid method development, qualitative detection, and the determination of samples with high analyte concentrations.

A simple fiber optics-based UV absorption system was used by Jinda and Cramer [84] to monitor the capillary

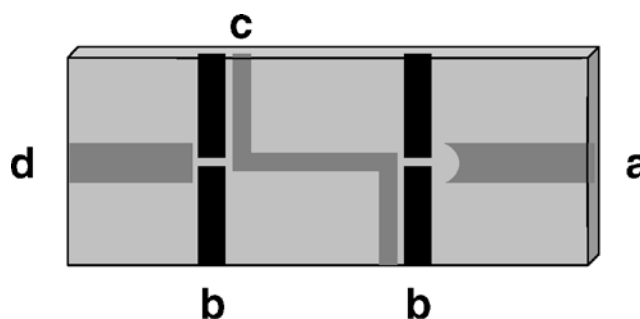

Fig. 9 Microchip with extended optical pathlength UV absorbance detection: *a*, channel for excitation fiber with cylindrical lens at the end; *b*, slit channels, filled with black ink; *c*, Z-shaped detection cell; *d*, channel for emission fiber

electrochromatographic separation of peptides. The separation channel of the microchip was partly filled with a sol-gel-immobilized stationary phase (C_4 -modified silica, 5 μm particles). UV absorption detection was carried out at the end of the channel without any stationary phase present. Using a XYZ translation stage, the chip was positioned between the ends of two optical fibers facing each other. The top fiber was connected to a deuterium–tungsten light source; the bottom optical fiber collected the transmitted light and guided it into a CCD array detector. The authors claim that the limit of detection achieved for thiourea (167 μM) could further be improved by noise reduction and by using a second detection channel for reference monitoring.

Hahn and coworkers [85] used a more complex three-layer chip design with two integrated optical fibers, a microlens and a pair of slits for extended optical path length absorbance detection (Fig. 9). The slit channels were filled with black ink to absorb any scattered light and to ensure that only the transmitted light is collected by the detection fiber. As light from an optical fiber is highly divergent, both excitation and detection fibers usually need to get very close to yield sufficient irradiance. To overcome this problem, the authors created a cylindrical microlens in the PDMS material at the end of the excitation fiber. In this way, the divergence was reduced so much that both fibers could still be operated at a distance of over 500 μm . This fact was utilized by extending the optical absorbance path length. The separation channel (50 μm width) could be redesigned, yielding a Z-shaped detection cell with an optical path length of 500 μm . As expected from Beer's law, the sensitivity could be increased by almost a factor of ten. The concentration detection limits for fluorescein, orange II and new coccine were 1.2, 2.9 and 3.5 μM , respectively.

Conclusions

Considering the number of publications on it over the last three years, fluorescence detection is clearly the most widespread optical detection technique used for microchip-based electrophoretic separations. While laser-induced fluorescence, with its superior sensitivity, only lacks a certain amount of flexibility regarding the choice of wavelengths, this gap is filled by less expensive lamp-based excitation sources. Depending on the application, the ability to choose the excitation wavelength frequently seems to compensate for a loss in sensitivity of ~ 2 – 3 decades. New designs, including integrated optical fibers and highly sensitive detectors, show that the sensitivity possible with lamp-based excitation can still be improved.

Light-emitting diodes (LED) are an even more cost-effective alternative for excitation sources. LEDs with higher

and higher outputs that cover almost the complete electromagnetic spectrum from near-UV to infrared have become available. Although they still show high intensity losses during focusing due to their high divergence, the next generation of high-output diodes with reduced radiation areas may be able to reach the sensitivities of LIF systems.

Chemiluminescence measurements are a very interesting alternative to fluorescence detection. These systems can be very simple and cost-effective since no light source and optical components are needed. Although the sensitivity is excellent due to the absence of excitation or stray light, these chemical systems are only applicable to a rather limited number of applications.

Compared to its importance in detection systems commonly used for conventional liquid phase separations, UV/vis absorbance measurement only plays a minor role in microchip applications. Noting Beer's law, the very short optical pathlengths of microfluidic devices result in low sensitivity. To minimize this problem, recent publications show the use of integrated optical fibers and detection cells with extended light paths. The versatility and ruggedness of (diode array) UV/vis detectors mean that they will become more prominent in applications where trace analysis is not the main focus.

Acknowledgements Financial support from the Nederlandse Organisatie voor Wetenschappelijk Onderzoek (NWO, Den Haag, The Netherlands) and the Fonds der Chemischen Industrie (Frankfurt, Germany) is gratefully acknowledged.

References

1. Dittrich PS, Tachikawa K, Manz A (2006) *Anal Chem* 78:3887–3907
2. Vilkner T, Janasek D, Manz A (2004) *Anal Chem* 76:3373–3385
3. Chen G, Lin Y, Wang J (2006) *Talanta* 68:497–503
4. Wang J (2005) *Electroanalysis* 17:1133–1140
5. Vandaveer WR, Pasas-Farmer SA, Fischer DJ, Frankenfeld CN, Lunte SM (2004) *Electrophoresis* 25:3528–3549
6. Sung W-C, Makamba H, Chen S-H (2005) *Electrophoresis* 26:1783–1791
7. Schwarz MA, Hauser PC (2001) *Lab Chip* 1:1–6
8. Mogensen K-B, Klank H, Kutter JP (2004) *Electrophoresis* 25:3498–3512
9. Uchiyama K, Nakajima H, Hobo T (2004) *Anal Bioanal Chem* 379:375–382
10. Viskari PJ, Landers JP (2006) *Electrophoresis* 27:1797–1810
11. Vasilyeva E, Woodard J, Taylor FR, Kretschmer M, Fajardo H, Lyubarskaya Y, Kobayashi K, Dingley A, Mhatre R (2004) *Electrophoresis* 25:3890–3896
12. Forrer K, Hammer S, Helk B (2004) *Anal Biochem* 334:81–88
13. Funes-Huacca M, Regitano LC, Mueller O, Carrilho E (2004) *Electrophoresis* 25:3860–3864
14. Ro KW, Hanh JH (2005) *Electrophoresis* 26:4767–4773
15. Lee S-H, Cho SI, Lee C-S, Kim B-G, Kim Y-K (2005) *Sens Actuators B* 110:164–173
16. Obeid PJ, Christopoulos TK, Ioannou PC (2004) *Electrophoresis* 25:922–930

17. Lacher NA, de Rooij NF, Verpoorte E, Lunte SM (2003) *J Chromatogr A* 1004:225–235
18. Sandlin ZD, Shou M, Shackman JG, Kennedy RT (2005) *Anal Chem* 77:7702–7708
19. Qin J, Ye N, Yu L, Liu D, Fung Y, Wang W, Ma X, Lin B (2005) *Electrophoresis* 26:1155–1162
20. Qin J, Leung FC, Fung Y, Zhu D, Lin B (2005) *Anal Bioanal Chem* 381:812–819
21. Giordano BC, Jin L, Couch AJ, Ferrance JP, Landers JP (2004) *Anal Chem* 76:4705–4714
22. Jemere AB, Oleschuk RD, Harrison DJ (2003) *Electrophoresis* 24:3018–3025
23. Smith Roddy E, Lapos JA, Ewing AG (2003) *J Chromatogr A* 1004:217–224
24. Etoh S, Fujimura T, Hattori R, Kuroki Y (2003) *Jpn J Appl Phys Pt 1* 42:4093–4097
25. Yang X, Zhang X, Li A, Zhu S, Huang Y (2003) *Electrophoresis* 24:1451–1457
26. Ling Y-Y, Yin X-F, Fang Z-L (2005) *Electrophoresis* 26:4759–4766
27. Beard NP, Edel JB, deMello AJ (2004) *Electrophoresis* 25:2363–2373
28. Gao J, Yin X-F, Fang Z-L (2004) *Lab Chip* 4:47–52
29. Skelley AM, Mathies RA (2003) *J Chromatogr A* 1021:191–199
30. Hata K, Kichise Y, Kaneta T, Imasaka T (2003) *Anal Chem* 75:1765–1786
31. Zhou X-M, Shao S-J, Xu G-D, Zhong R-T, Liu D-Y, Tang J-W, Gao Y-N, Cheng S-J, Lin B-C (2005) *J Chromatogr B* 816:145–151
32. Liu D, Zhou X-M, Zhong R, Ye N, Chang G, Xiong W, Mei X, Lin B-C (2006) *Talanta* 68:616–622
33. Liu B-F, Hisamoto H, Terabe S (2003) *J Chromatogr A* 1021:201–207
34. Qin J, Fung Y, Zhu D, Lin B-C (2004) *J Chromatogr A* 1027:223–229
35. Schulze P, Ludwig M, Kohler F, Belder D (2005) *Anal Chem* 77:1325–1329
36. Li H-F, Lin J-M, Su R-G, Uchiyama K, Hobo T (2004) *Electrophoresis* 25:1907–1915
37. Li H-F, Cai Z-W, Lin J-M (2006) *Anal Chim Acta* 565:183–189
38. Hsiung S-K, Lin C-H, Lee G-B (2005) *Electrophoresis* 5:1122–1129
39. Fu J-L, Fang Q, Zhang T, Jin X-H, Fang Z-L (2006) *Anal Chem* 78:3827–3834
40. Shen Z, Liu X, Long Z, Liu D, Ye N, Qin J, Dai Z, Lin B (2006) *Electrophoresis* 27:1084–1092
41. Gao Y, Shen Z, Wang H, Dai Z, Lin B (2005) *Electrophoresis* 26:4774–4779
42. Fruetel J, Renzi RF, VanderNoot VA, Stamps J, Horn BA, West JAA, Ferko S, Crocker R, Bailey CG, Arnold D, Wiedenman B, Choi W-Y, Yee D, Shokair I, Hasselbrink E, Paul P, Rakestraw D, Padgen D (2005) *Electrophoresis* 26:1144–1154
43. Renzi RF, Stamps J, Horn BA, Ferko S, VanderNoot VA, West JAA, Crocker R, Wiedenman B, Yee D, Fruetel JA (2005) *Anal Chem* 77:435–441
44. Mourzina Y, Steffen A, Kalyagin D, Carius R, Offenhäusser A (2005) *Electrophoresis* 26:1849–1860
45. Varjo SJO, Ludwig M, Belder D, Riekkola M-L (2004) *Electrophoresis* 25:1901–1906
46. Wicks DA, Li PCH (2004) *Anal Chim Acta* 507:107–114
47. Starkey DE, Abdelaziez Y, Ahn CH, Tu J, Anderson L, Wehmeyer KR, Izzo NJ, Carr AN, Peters KG, Bao JJ, Halsall HB, Heineman WR (2003) *Anal Biochem* 316:181–191
48. Piehl N, Ludwig M, Belder D (2004) *Electrophoresis* 25:3848–3852
49. Kato M, Gyoten Y, Sakai-Kato K, Toyo'oka T (2003) *J Chromatogr A* 1013:183–189
50. Lin C-C, Chen C-C, Lin C-E, Chen S-H (2004) *J Chromatogr A* 1051:69–74
51. Gong M, Wehmeyer KR, Limbach PA, Arias F, Heineman WR (2006) *Anal Chem* 78:3730–3737
52. Yan Q, Chen R-S, Cheng J-K (2006) *Anal Chim Acta* 555:246–249
53. Han J, Singh AK (2004) *J Chromatogr A* 1049:205–209
54. Zhang C-X, Manz A (2003) *Anal Chem* 75:5759–5766
55. Götz S, Karst U (2006) *Sens Actuators B* (accepted)
56. Götz S, Revermann T, Karst U (2006) *Lab Chip* (accepted)
57. Revermann T, Götz S, Karst U (2006) *Electrophoresis* (accepted)
58. Dang F, Kakehi K, Nakajima K, Shinohara Y, Ishikawa M, Kaji N, Tokeshi M, Baba Y (2006) *J Chromatogr A* 1109:138–143
59. Dang F, Zhang L, Hagiwara H, Mishina Y, Baba Y (2003) *Electrophoresis* 24:714–721
60. Dang F, Zhang L, Jabasini M, Kaji N, Baba Y (2003) *Anal Chem* 75:2433–2439
61. Matsuno Y-K, Kinoshita M, Kakehi K (2005) *J Pharm Biomed Anal* 37:429–436
62. Ping G, Zhu B, Jabasini M, Xu F, Oka H, Sugihara H, Baba Y (2005) *Anal Chem* 77:7282–7287
63. Miyaki K, Guo Y, Shimosaka T, Nakagama T, Nakajima H, Uchiyama K (2005) *Anal Bioanal Chem* 382:810–816
64. Guo Y, Uchiyama K, Nakagama T, Shimosaka T, Hobo T (2005) *Electrophoresis* 26:1843–1848
65. Yao B, Luo G, Wang L, Gao Y, Lei G, Ren K, Chen L, Wang Y, Hu Y, Qiu Y (2005) *Lab Chip* 5:1041–1047
66. Liu B-F, Ozaki M, Utsumi Y, Hattori T, Terabe S (2003) *Anal Chem* 75:36–41
67. Liu B-F, Ozaki M, Hisamoto H, Luo Q, Utsumi Y, Hattori T, Terabe S (2005) *Anal Chem* 77:573–578
68. Su R, Lin J-M, Qu F, Chen Z, Gao Y, Yamada M (2004) *Anal Chim Acta* 508:11–15
69. Su R, Lin J-M, Uchiyama K, Yamada M (2004) *Talanta* 64:1024–1029
70. Huang X, Ren J (2005) *Electrophoresis* 26:3595–3601
71. Qiu H, Yan J, Sun X, Liu J, Cao W, Yang X, Wang E (2003) *Anal Chem* 75:5435–5440
72. Zhao X, You T, Qiu H, Yan J, Yang X, Wang E (2004) *J Chromatogr B* 810:137–142
73. Qiu H, Yin X-B, Yan J, Zhao X, Yang X, Wang E (2005) *Electrophoresis* 26:687–693
74. Du Y, Wei H, Kang J, Yan J, Yin X-B, Yang X, Wang E (2005) *Anal Chem* 77:7993–7997
75. Faure K, Loughran M, Glennon JD (2006) *Anal Chim Acta* 557:130–136
76. Wakida S-I, Fujimoto K, Nagai H, Miyado T, Shibutani Y, Takeda S (2006) *J Chromatogr A* 1109:179–182
77. Stettler AR, Schwarz MA (2005) *J Chromatogr A* 1063:217–225
78. Xu Z, Nishine T, Arai A, Hirokawa T (2004) *Electrophoresis* 25:3875–3881
79. Xu Z, Ando T, Nishine T, Arai A, Hirokawa T (2003) *Electrophoresis* 24:3821–3827
80. Xu ZQ, Hirokawa T, Nishine T, Arai A (2003) *J Chromatogr A* 990:53–61
81. Suzuki S, Ishida Y, Arai A, Nakanishi H, Honda S (2003) *Electrophoresis* 24:3828–3833
82. Guihen E, Glennon JD (2005) *J Chromatogr A* 1071:223–228
83. Ludwig M, Kohler F, Belder D (2003) *Electrophoresis* 24:3233–3238
84. Jinda R, Cramer SM (2004) *J Chromatogr A* 1044:277–285
85. Ro KW, Lim K, Shim BC, Hahn JH (2005) *Anal Chem* 77:5160–5166