

SLAC-PUB-5070  
LBL-27760  
UCRL-101688  
August 1989  
(A/E)

## Recent Progress in Relativistic Klystron Research\*

M. A. Allen, R. S. Callin, H. Deruyter, K. R. Eppley, K. S. Fant, W. R. Fowkes, H. A. Hoag, R. F. Koontz, T. L. Lavine, G. A. Loew, R. H. Miller, R. D. Ruth, A. E. Vlieks, J. W. Wang  
Stanford Linear Accelerator Center, Stanford, California 94309

D. P. Aalberts, J. K. Boyd, T. Houck, R. D. Ryne, G. A. Westenskow, S. S. Yu  
Lawrence Livermore National Laboratory, Livermore, California 94550

D. B. Hopkins, A. M. Sessler,  
Lawrence Berkeley Laboratory, Berkeley, California 94720

J. Haimson, B. Mecklenburg  
Haimson Research Corporation, Palo Alto, California 94303

presented by G. A. Westenskow

---

### Abstract

*Experimental work is now under way by collaborators at LLNL, SLAC, and LBL to investigate relativistic klystrons as a possible rf power source for future high-gradient accelerators. We have learned how to overcome our previously reported problem of high-power rf pulse shortening and have achieved peak rf power levels of 290 MW. We have used the rf from a relativistic klystron to power a short, 11.4-GHz high-gradient accelerator. The measured momentum spectrum of the accelerated electron beam corresponds to an accelerating gradient of 84 MV/m.*

### Introduction and Background

During the past year researchers at Stanford Linear Accelerator Center and Lawrence Berkeley Laboratory have continued a collaborative effort with investigators at Lawrence Livermore National Laboratory to study some basic physics issues involved in combining linear induction accelerators with relativistic klystrons. In previous papers<sup>1,2</sup> we have reported results obtained with two experimental relativistic klystrons: a

subharmonic buncher relativistic klystron ("SHARK"); and a multicavity klystron at 11.4 GHz ("SL4"). Current experiments are being performed using beams with  $\approx 1.2$  MeV of kinetic energy and  $\approx 700$  A of current with a  $\approx 50$ -ns duration.

SHARK is a low-gain, two-cavity tube driven by a 4-MW, 5.7-GHz source and has output power at 11.4 GHz. It provides a test bed for studying cavity performance and beam-cavity interactions. We have tested several variants of SHARK, including one with an iron magnetic shunt around the drive cavity, one with slotted noses to combat multipactor, one with a penultimate cavity to improve gain and efficiency, and one with the single standing-wave output cavity replaced by a six-cell traveling-wave output structure to reduce electric fields. The maximum rf output level obtained from SHARK is 100 MW from a 1.1-MV, 400-A beam. At this current, saturation limits the output power. At higher currents, output power is limited by beam loading of the input cavity.

SL4 is an 11.4-GHz, six-cavity, high-gain klystron. Previously, peak rf power of 200 MW had been achieved with a standing-wave output cavity, but only with

---

\* Work supported in part by the Department of Energy, contract numbers W-7405-ENG-48 (LLNL), DE-AC03-76SF00515 (SLAC), and DE-AC03-76SF00098 (LBL).

an rf flat-top of much shorter duration than the beam pulse. The maximum reasonably flat rf pulse achieved in our initial test was only 70 MW. Use of a traveling-wave output structure increased the flat pulse to 170 MW. This configuration had three intermediate gain cavities, a gain of  $\approx 52$  dB, and about 30% efficiency. Phase stability measurements indicated that the output pulse was satisfactory for driving a high-gradient rf accelerator. Results from a new version, in which a 290 MW output pulse is obtained with multi-output cavities, are presented below.

An approach for current modulation of a higher energy electron beam using a transverse chopper system<sup>3</sup> is ready for testing. With the problem of pulse shortening alleviated, our main effort now is toward developing higher-energy klystrons and multi-cavity extraction devices, toward cost reduction, and toward improving the efficiency of relativistic klystrons. We have also recently performed work with a high-gradient accelerator, which is described below.

### MOK-2

MOK-2 is a multi-output klystron with two outputs operating with high-gain klystron at 11.4 GHz. Figure 1 shows a layout of the tube. The tube was designed

for a 1.3-MV beam. Figure 2 shows a computer prediction of the output from MOK-2. The first four cavities are the same as those used in SL4. The first output is a single standing-wave (SW) resonant cavity located 21 cm after the last gain cavity. It has  $Q = 17$  and  $R/Q = 175 \Omega$ . The drift tube diameter of the SW cavity is 11.4 mm. This output cavity serves two purposes: it extracts power from the beam, and it further bunches the beam. Past experience with breakdown phenomenon in output cavities led to a decision to keep the output power below 100 MW for a SW output cavity with  $Q \approx 20$ .

The second output is a traveling-wave (TW) structure and is located 14 cm beyond the SW output cavity. The 11.4-GHz TW structure<sup>3</sup> is comprised of six  $2\pi/3$ -mode cells with beam apertures of 14 mm (0.53 free-space wavelengths), and has an electrical length of 4.8 cm, an rf filling time of 1 ns, and a varying phase velocity tapering from  $0.94c$  at entry to  $0.90c$  at the output coupler. The TW circuit was designed to generate 250 MW of output power when operating under synchronous conditions at an rf current of 520 A. At this power level the average electric field in the the output coupler is 40 MV/m, and the peak loss of beam energy in traversing the circuit is approximately 0.9 MeV.

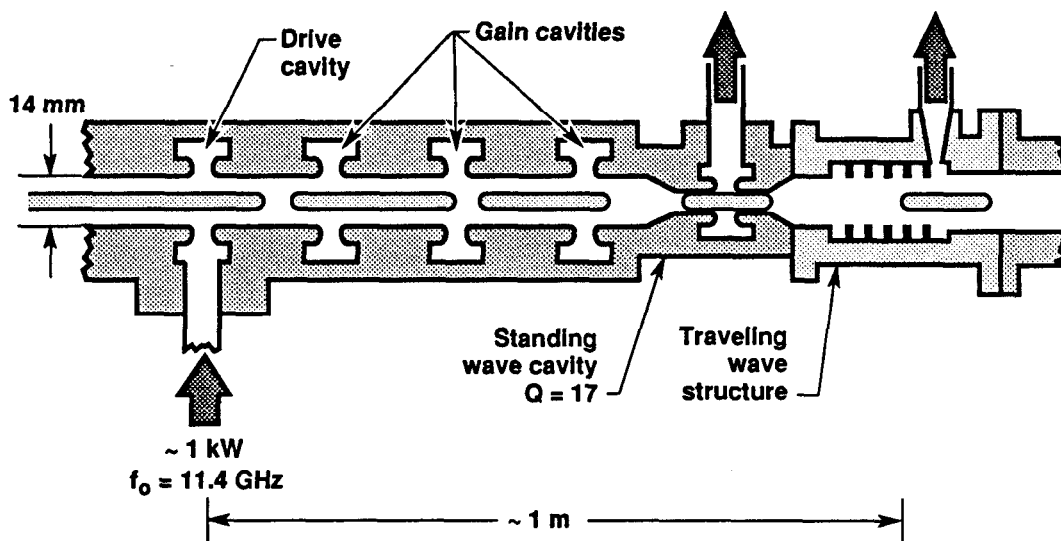

Figure 1. Diagram of MOK-2.

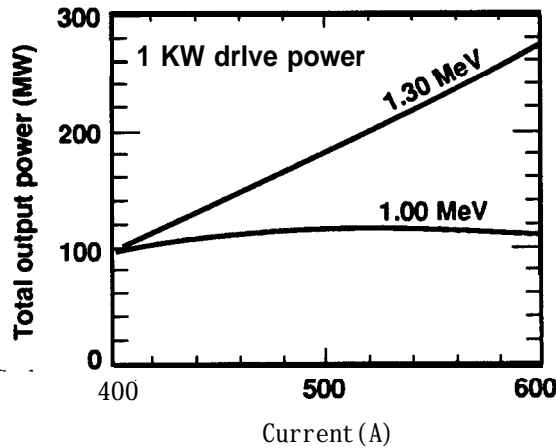

Figure 2. Computer prediction for the total rf output power from MOK-2.

Extrapolation from computer modeling indicates that the output power from the TW output structure can reach 500 MW before surface field strengths exceed 200 MV/m. Since the output electric fields are inversely proportional to the rf interaction length, the multi-cell extraction structure in general exhibits significantly lower electric fields than the single resonant extraction cavity for equal power levels. However, the longer interaction length makes the TW structure more susceptible to higher-order mode difficulties and, in particular, of the buildup to beam breakup fields<sup>2,3</sup>.

#	Type	z (cm)	f-f <sub>0</sub> (MHz)	Q*	R/Q** (Ω)
1	Drive	0	4	315	160
2	Gain	28	-31	117	160
3	Gain	42	+23	122	160
4	Gain	63	+45	119	160
5	SW Out	85	106	17	175
6	TW Out	99***	0	-	-

f<sub>0</sub> = 11.424 GHz, \* Beam-off loaded Q.  
 \*\* Urmel Calculation, \*\*\* To center of structure

To date, the highest power measured from the TW output structure is 260 MW. The highest total power measured from both structures is 290 MW (60 MW from the SW cavity and 230 MW from the TW structure, see Fig. 3). The current through the klystron was 600 A and the beam voltage was 1.3 MV. The drive beam energy-spread increases for beam voltages above 1.2 MV with the present injector. Additional energy spread leads to increased phase variation in the rf output and narrowing of the transmitted current pulse through the klystron. We have had limited experience with the MOK-2 tube to date, and will continue to search for improved operating conditions. In addition we will study phase stability between the two output cavities.

#### Traveling-wave output pulse

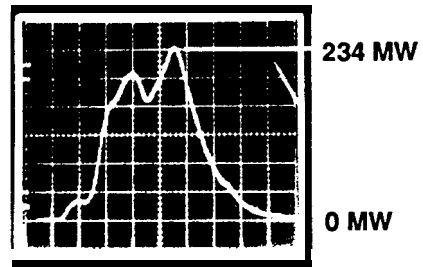

#### Standing-wave output pulse

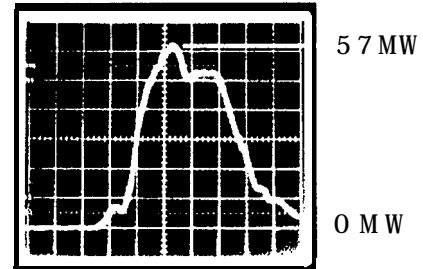

10ns/div

Figure 3. Output pulse of the traveling-wave structure and the standing-wave cavity of MOK-2.

The input cavity performance of MOK-2 is similar to SL4 (the same cavity is used in both klystrons). Our studies of SL4 demonstrated input cavity loading by charged particles other than the beam

(presumably multipactor) when the rf drive level exceeded 40 W. Once initiated by electrons from the warm gun cathode, this loading phenomenon was observed to persist even with the cathode cold and the beam off; loading was sustained by the presence of an axial magnetic focusing field. This cavity loading phenomenon, which was observed both with and without the beam, may occur in any of the cavities of the multicavity klystron and may be related to pulse shortening. This additional loading of the drive cavity did not seem to affect the rf pulse width; however, it did alter the electric field levels in the cavity for a given rf drive level. The unknown extent of additional loading makes it difficult to compare experimental results with computer predictions. Use of additional drive power (above 1 kW) will sometimes stop the multipactor in the input cavity. The input rf is supplied by an X-band TWT amplifier.

### High-Gradient Accelerator

To study high-gradient acceleration, we built a 26-cm-long section of 11.4-GHz accelerator structure operating in the  $2\pi/3$  traveling wave mode. The constant-impedance structure consists of 30 cells and has  $r/Q = 14 \text{ k}\Omega/\text{m}$ . The filling time of the structure is 28 ns and the group velocity

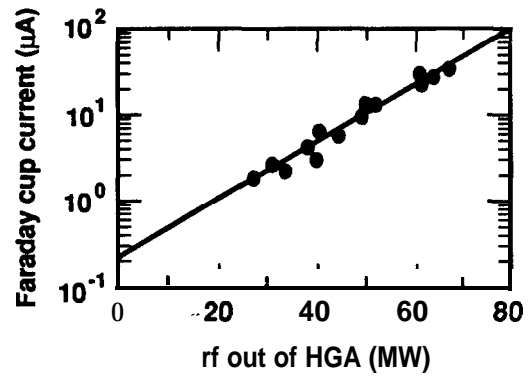

Figure 4. Dark current from HGS

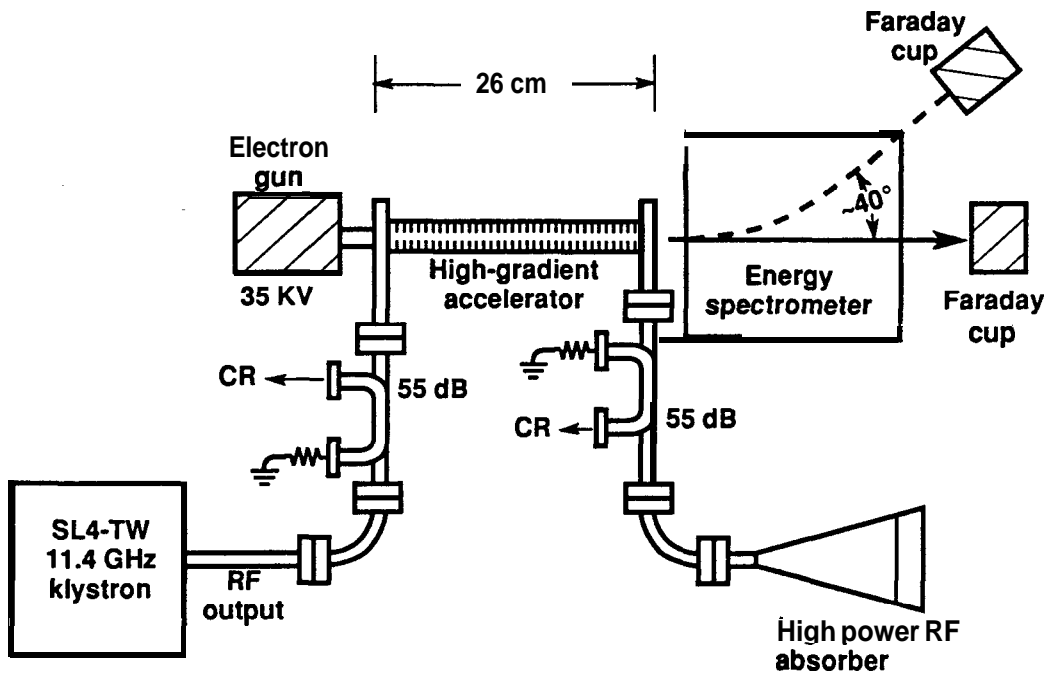

Figure 5. Layout of high-gradient accelerator.

is **0.031c**. The accelerating field on axis, for klystron power  $P$ , is  $100 \text{ MV/m} \times [P/(100\text{MW})]^{1/2}$ . Power through the structure is attenuated by 24%. The iris diameter was chosen to be 7.5 mm. The accelerator was **frabricated** from machined "cups," which were stacked and brazed.

Field emission in the high-gradient structure (**HGS**) was measured in the absence of any injected beam. The field emission current was measured by integrating the charge desposited in a Faraday cup at the output end of the accelerator and assuming that the duration was comparable to that of the rf pulse. After rf processing for 80 hours at 1 **pulse/sec** the field-emission currents measured as a function of klystron power,  $P$ , are consistent with the empirical relationship:  $250 \text{ nA} \times \exp(P/(13\text{MW}))$ . Fowler-Nordheim analysis of the data<sup>4</sup> indicates a local surface field enhancement factor between 60 and 70.

Electrons from a  $0.5\text{-cm}^2$  thermionic cathode were injected into the accelerator using a **35-kV** gun pulsed for 5 ns. *Prior* to installation of the gun, persistent arcing was not apparent in the HGS at power levels as high as 160 MW. After installation arcing became persistent at klystron power levels in excess of 100 MW. We are examining whether the reduction in **holdoff** arose from cathode contamination or from surface damage of the copper parts in the HGS.

The beam emerging from the accelerator was momentum-analyzed using a spectrometer consisting of a  $40^\circ$  horizontal bend, a 2.5-cm diameter collimator, and a Faraday cup. The momentum resolution,  $\sigma_p/p$ , of the spectrometer was about **14%**, mainly because of mutiple scattering in the **0.5-mm-thick** aluminum window at the end of the accelerator. The measured momentum spectrum of the accelerated electron beam is nearly Gaussian with peak  $p = 17 \text{ MeV/c}$ , half-width  $\sigma_p = 3 \text{ MeV/c}$ , and a slight low-momentum tail (see Fig. 6). At  $20^\circ\text{C}$  the phase velocity in the HGS is equal to the speed of light for  $f = 11.436 \text{ GHz}$ . We usually operated near

**11.467 GHz** to increase capture efficiency. Computer modeling of the accelerator beam dynamics using the particle tracking code PARMELA indicates that the injected electrons slip in phase relative to the rf wave, and that for BO-MW of klystron power, as measured, the total energy gain expected is **16 MeV**, consistent with that observed. The maximum energy gain for synchronous particles, calculated from the

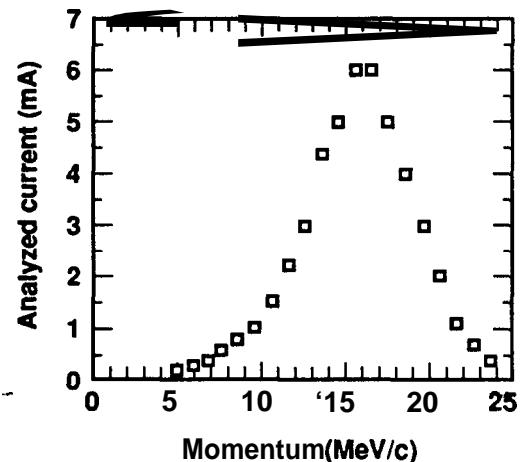

Figure 6. Analyzed momentum spectrum from the HGA.

BO-MW power level, is **23 MeV**, corresponding to an average accelerating gradient of **84 MV/m** in the **26-cm-long** accelerator. The power measurement is uncertain by **10%**, corresponding to an uncertainty of 5% in the gradient. Beam and rf pulses for this gradient are shown in Figure 7.

### **Future work**

Two high-gradient structures are being prepared for the two-output klystron. The phase difference between the structures will be adjusted by changing the spacing between the accelerating structures. Designs of a three-output cavity klystron operating with **1.2-MV** electron beam are under study. Work is in progress to increase the beam voltage above 1.4 MV to allow high efficiency klystrons to be tested as

well as klystrons with additional output ports. A second pulse-power compression system will be used to drive additional induction cells. We have submitted a proposal that would allow us to relocate to a better shielded facility where rf conditioning can be studied, and where we can use high-power FEL sources<sup>5</sup>.

Hoyt, T. G. Lee, P. L. Morton, V. K. Neil, R. B. Palmer, A. C. Paul, L. L. Reginato, A. C. Smith, G. Spalek, K. Whitham, P. B. Wilson, D. Yu, and L. Zitelli. for engineering and technical assistance, we thank D. L. Bix, G. A. Deis, R. A. Early, S. A. Hawkins, R. M. Hill, C. Pearson, H. D. Schwarz, and D. O. Trimble.

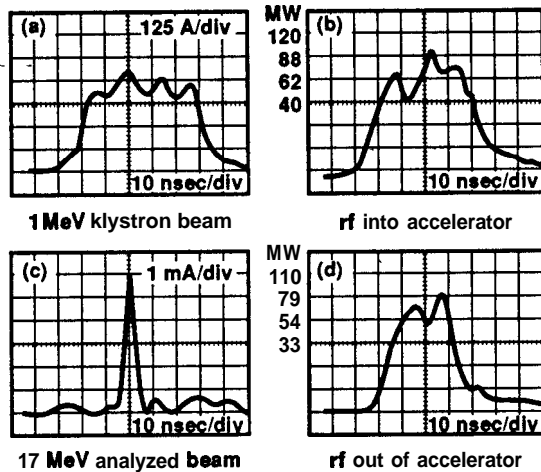

Figure 7. Beam and rf conditions during a high-gradient accelerator test.

### Acknowledgements

For helping to make this work possible, we thank W. A. Barletta, R. J. Briggs, T. J. Orzechowski, J. M. Paterson, and D. S. Prono. For helpful discussions, we thank G. J. Caporaso, M. Chodorow, Y. Goren, W. B. Herrmannsfeldt, E. W.

### References

1. M.A. Allen et al., "Relativistic Klystron Research for High Gradient Accelerators," SLAC-PUB-4650 (June 1988), published in Proceedings of the European Particle Accelerator Conference, Rome, Italy, June 7-11, 1988.
2. M.A. Allen, et. al., "Relativistic Klystron," SLAC-PUB-4861, published in Proceedings of the IEEE Particle Accelerator Conference, Chicago, Illinois, March 20-23, 1989.
3. J. Haimson and B. Mecklenburg, "Design and Construction of a Chopper Driven 11.4 GHz Traveling Wave RF Generator: 1989 IEEE Particle Accel. Conf., loc. cit.
4. J. W. Wang and G.A. Loew, SLAC-PUB-4866(1989), also in 1989 IEEE Particle Accel. Conf., loc. cit.
5. R. A. Jong, et. al., "17.1 GHz Free-Electron Laser as a Microwave Source for TeV Colliders", to be presented at the 1989 FEL Conference, Naples, Florida Aug. 28-Sept.1, 1989