

9-10-93

E-7923

NASA Technical Memorandum 106214
AIAA-93-1902

Recent Testing of 30 kW Hydrogen Arcjet Thrusters

Thomas W. Haag
Lewis Research Center
Cleveland, Ohio

Prepared for the
29th Joint Propulsion Conference and Exhibit
cosponsored by the AIAA, SAE, ASME, and ASEE
Monterey, California, June 28-July 1, 1993



RECENT TESTING OF 30 KW HYDROGEN ARCJET THRUSTERS

Thomas W. Haag
National Aeronautics and Space Administration
Lewis Research Center
Cleveland, Ohio 44135

ABSTRACT

NASA is conducting efforts to evaluate high-power hydrogen arcjets for orbit transfer propulsion applications. As part of this program, an attempt was made to reexamine both radiatively- and regeneratively-cooled, 30 kW thrusters first demonstrated by the Giannini Scientific Corp. in 1963. The arcjets were configured to force arc attachment upstream of the throat in a subsonic chamber region. While thruster currents were steady, the voltage traces exhibited sawtooth waveforms at frequencies on the order of 20 kHz. Voltage variations per cycle were typically between 100 and 310 volts, indicating major changes in the position of the arc attachment with time. When operated at their respective design points, the performance of both thrusters fell below the values listed in the 1960's development reports. The reason for the discrepancies is not currently understood and further investigations are in progress. However, the recently measured efficiencies were high compared to those obtained with constricted-arc designs at similar conditions, and further arcjet performance optimizations may be possible.

INTRODUCTION

The first government sponsored arcjet development programs began in the late 1950's and for the most part focused on 30 kW hydrogen thrusters for orbit transfer and translunar missions. At that time, space-based nuclear power was anticipated, and the high specific impulse offered by the arcjet made it a serious alternative to existing chemical propulsion systems.¹ The development programs continued through the mid-1960's with most of the effort performed by the Avco Corp. and the Giannini Scientific Corp. under contracts from NASA and the Air Force, respectively.

The Avco program culminated in a radiation-cooled 30 kW constricted-arc engine designated as the R-4 mod 1.² In that arcjet, the arc seated in the supersonic flow region of the anode. The thruster demonstrated a specific impulse(Isp) of 1010 seconds and a thrust efficiency of 0.41. A 723 hour endurance test was successfully completed at that performance level.

Concurrently, the Giannini Scientific Corp.(GSC) developed a radiation-cooled 30 kW hydrogen arcjet designated as model 141-300, in which the arc was forced to seat in a subsonic region upstream of the nozzle throat.³ The performance obtained with this device was very similar to the Avco R-4 mod 1 thruster. Development at GSC continued and ultimately a regeneratively-cooled design, designated as model 141-400, was completed.⁴ The thruster demonstrated a specific impulse of 1000 s at an efficiency of 0.55, and a lifetest of 500 hours was completed. Independent testing of the GSC regenerative thruster was performed by the McDonnell Corp. under a NASA contract in 1965.⁵ In those tests, an efficiency of 0.50 was obtained at a specific impulse of 970 seconds.

Multiple diagnostic studies were conducted via stagnation enthalpy sweeps, Langmuir probes, photometric velocity determinations, and direct thrust measurements.

While development of arcjet thrusters was largely successful, interest in high power electric propulsion began to diminish. The SNAP 8 nuclear reactor experienced development problems, and its weight estimate had increased to over 4 tons. In addition, technical breakthroughs with hydrogen/oxygen chemical engines were realized which promised large gains in mission capabilities, and most development work on arcjet propulsion was discontinued by the late 1960's.

With initiation of the SP-100 program and advances in photovoltaic technology, there was renewed interest in high-power arcjet propulsion for orbit transfer.⁶ Initial tests were conducted with Avco-type thruster designs operating on ammonia.⁷ At present, interest exists^{8,9} in 10 kW hydrogen arcjets for a solar electric orbit transfer vehicle. Rocket Research Corp., under a government contract, performed a limited development effort to scale the 30 kW GSC regenerative arcjet to a 10 kW power level.¹⁰ Unfortunately, the performance of the scaled designs fell short of the original 30 kW thruster. NASA Lewis is currently supporting an in-house program to develop this technology. The program consists of both thruster and power processor development.^{11,12} As part of this program, an attempt was made to reproduce performance obtained with the Avco and GSC 30 kW designs. It is hoped that a true understanding of past designs will provide insight as to how these devices could be successfully scaled to 10 kW power levels. This paper reports on recent testing of a radiation-cooled and regeneratively-cooled arcjets which were similar to the respective GSC designs tested in the 1960's.

APPARATUS

Because the ultimate goal of this series of tests was to verify the performance obtained during the early 1960's, there was no attempt to improve on the older designs. Original geometries, especially involving the electrodes, were reproduced as closely as could be determined from tabulated dimensions and scale figures. GSC models 141-300 and 141-400 are shown schematically in Figure 1.^{3,5} The electrode configurations in these two thrusters were similar and designed so that the arc would be contained in a subsonic arc chamber region. The arc would establish an anode attachment on the chamber wall upstream of the nozzle throat. Operation in this high pressure region was thought to reduce frozen flow losses by promoting recombination of dissociated gases before they exited the thruster.

Giannini Model 141-300 Replica

Dimensions for the original 141-300 anode and nozzle were obtained from Reference 3, and are summarized in Table I. The arc chamber measured 6.35 mm in diameter and approximately 28 mm in length. The heated gas passed through a 4.75 mm diameter throat before expanding out a 15° half-angle conical nozzle. The exit diameter of the nozzle was 35.5 mm, resulting in an exit to throat area ratio of 56:1. The cathode for the original thruster consisted of a 2 % thoriated tungsten rod 11 mm in diameter with a 45° conical tip at the point of arc attachment.

Experience with radiation-cooled thrusters indicates that nearly all performance characteristics are determined by nozzle and electrode geometry. In an attempt to reestablish and confirm the performance of model 141-300, the original geometry was copied as closely as was practical. The nozzle used in these tests was machined from 2% ThO₂/W according to the schematic shown in Figure 2(a). Because little documentation was available about the remainder of the original thruster design, existing 30 kW arcjet hardware¹¹ was used to hold the Giannini-type electrodes. To make this possible, the nozzle exit diameter was reduced to 24.6 mm (see Table I), resulting in an exit to throat area ratio of 27:1, about half that of the original model. The front assembly consisted of a TZM anode housing into which the tapered nozzle was abrasively lapped (Fig. 2(b)). At the core of the front assembly was a boron nitride insulator and propellant injector. Propellant was injected into the arc chamber through a uniform annular flow path. No swirl component was induced to the flow field, corresponding to the earlier GSC design.

The rear assembly consisted of a stainless steel containment structure and ceramic insulator. Components were welded and brazed together, resulting in a hermetically sealed unit. Propellant entered the thruster through an inlet

tube welded into the side of the containment structure. A heat resistant Inconel spring was located in this area and was used to preload the front assembly.

Front and rear assemblies were joined and sealed with a graphite gasket. Two flexible molybdenum flange plates were bolted together and preloaded to maintain uniform compression between the two assemblies. The electrode arc gap was set by withdrawing the cathode rod 2.54 mm from its contact position with the anode. The cathode was locked in position by tightening a compression type fitting at the rear of the thruster. The thruster was then pressurized and leak checked.

Giannini 141-400 Replica

The electrode geometry of the regeneratively-cooled model 141-400 (Fig. 1(b)) was quite similar to that of the radiation-cooled model 141-300 (Fig. 1(a))⁴. The only significant difference in anode geometry was the expansion of the original arc chamber into a mixing chamber region. This has been referred to as a semi-constricted design, where the arc column proceeds downstream past the anode entrance and then attaches on a flared section of the anode wall. While the inner diameter of the anode entrance remained at 6.35 mm, as indicated in Table I, the inner diameter of the mixing chamber expanded to 7.92 mm over an axial distance of 15 mm. The propellant heated in this region then passed through a 4.75 mm throat to a 60:1 area ratio diverging nozzle.

While there were minor differences in anode geometry, the major innovation of the regenerative thruster was an elaborate series of flow passages which preheated the propellant prior to injection into the arc. During normal operation, 93% of the flow entered the main propellant inlet and was directed through a long helical path within the outer contour of the thruster housing. The gas then passed between the outside surface of the diverging nozzle and an internal flow guide. At this point the propellant was directed over the outer surface of the arc chamber, which was probably the hottest surface in the thruster. The hot propellant was injected radially inward through twelve evenly spaced 3.18 mm diameter holes, impinging onto the cathode rod. Here the main propellant flow mixed with the remaining 7% of the flow, which had been used to cool the rear parts of the thruster and cathode. The combined propellant flow was directed through the arc chamber and out the thruster nozzle.

The regenerative thruster used in recent tests (Fig. 3) was a near copy of the original model 141-400. Two minor differences in the rear area included the replacement of metallic K-seals with graphite gaskets and the addition of a flexure disk to accommodate axial expansion of internal components. While these modifications were made out of practicality, it is believed that their location in the far upstream end of the thruster would have a negligible effect on performance. When fully assembled the thruster was pressurized and leak checked.

Facility and Support Equipment

The test facility used in this study had previously been used for testing hydrogen arcjets ranging from 5 to 40 kW in power.¹¹ The main vacuum chamber was 4.6 m in diameter and 20 m in length. A thrust stand was installed in a 0.9 m diameter port extension to the main chamber and could be isolated through a 0.9 m gate valve. The port extension was perpendicular to the long axis of the main chamber. The thruster plume impinged on a graphite target positioned on the opposing chamber wall. Pumping in this facility was provided by four rotary blowers with a combined effective capacity of 5.8 m³/s. The blowers discharged into three 0.24 m³/s reciprocating vacuum pumps, which in turn discharged to the atmosphere. Ambient background pressure in the facility ranged from 50 to 160 Pa (0.5 to 1.2 torr), depending on propellant flow rate. Pressure was measured with a capacitance manometer type transducer and displayed on a digital readout.

Electrical power to the arcjet was provided by an arrangement of ballast resistors and dc power supplies (Fig. 4). Two 30 kW power supplies provided the majority of current needed for testing. Combined in parallel, they could supply 120 A at up to 500 V. An extra 10 kW power supply was later added to provide an additional 25 A during times of maximum current demand. Blocking diodes were placed on the negative terminal of each supply to protect them from high voltage ignition and eliminate reverse current surges among various power supplies. A 0.5 mH inductor and 1.8 Ω resistor were placed in series with the cathode terminal of the thruster to provide arc stability. Initial breakdown was achieved with a 1200 V igniter, which could maintain a current of up to 0.5 A. Glow to arc transition was accomplished with a 600 V, 18 A power supply. After transition, the arc voltage was usually low enough for the main power supplies to slowly ramp up to the desired operating level.

Arc current was measured with a 500 A, 50 mV shunt. The shunt was connected to an electrically isolated digital voltmeter, which permitted current resolution to within 0.1 A. Transient arc current was monitored with a digital oscilloscope through a Hall effect current probe, at sampling rates up to 10⁷/s. Average voltage values were measured with an electrically isolated digital voltmeter. Transient voltage was monitored by the digital oscilloscope through 100:1 voltage divider probes.

Thrust measurements were obtained with a calibrated displacement type thrust stand (Figs. 5(a) and 5(b)). This unit had been used in previous arcjet tests and could internally transfer up to 300 A of discharge current from facility power supplies to the mounted thruster.¹¹ The thruster mounting platform was supported by an upright flexure arrangement, which restricted all motion except for that along an axis parallel to the thrust vector. A linear variable differential transformer (LVDT) was used

to measure thrust induced displacements up to 5 mm in magnitude with a resolution of 0.001 mm. The analog output of the LVDT electronics was wired to a strip chart recorder, which provided a permanent record of test operations.

Arcjet propellant was transferred through the thrust stand by means of an internal propellant flexure. Cooling water was transferred on and off the stand through similar flexure tubes. A water-cooled copper enclosure surrounded the entire thrust stand assembly to prevent radiant heat from impinging on the flexures and structural components.

In-situ calibration was performed using three 981 mN (100 gram) weights. The weights would engage the thrust stand through a monofilament line which passed over a precision pulley. Each weight was lowered manually by turning a rotary vacuum feed through. A complete detailed description of the thrust stand can be found in reference 11.

Two different propellant flow rates could be measured and regulated simultaneously. A 200 SLPM flow controller was used for main propellant flow, and a 30 SLPM flow controller was used for secondary flow. A digital pressure transducer was connected to the secondary flow channel and was used to monitor inlet feed pressure to the thruster.

Ultra high purity (99.999%) gaseous hydrogen was stored in high pressure bottles and regulated to 1 MPa, where it entered the flow controllers. An electrical interlock circuit disabled the arc power supplies if hydrogen bottle pressure dropped below 620 kPa. The hydrogen flow controllers were calibrated in-situ and provided a digital readout of propellant feed rates to an accuracy of about 1% full scale.

A two color pyrometer with a range of 1400 °C to 2600 °C was used to observe the nozzle temperature of the radiation-cooled arcjet thruster. A chromel-alumel thermocouple was used to monitor the housing temperature of the regenerative arcjet thruster. The thermocouple was spot welded directly to the molybdenum surface and covered with a small radiation shield.

EXPERIMENTAL PROCEDURE

Each session of testing began with cold flow thrust measurements. This not only provided a point of comparison with published data, but also verified operation of the facility and instrumentation. The hydrogen flow controller was set to a specified flow rate and allowed to equilibrate for a few minutes before final measurements were taken. Because of the large volume of the vacuum facility and relatively low speed of the mechanical pumps, it would typically take at least 5 minutes for the facility background pressure to stabilize at any given flow rate.

The thruster was brought to a steady-state operating level in stages to prevent damaging current surges or unintentional arc termination. An initial flow

rate of 100 mg/s usually resulted in the most reliable and non-damaging startup behavior. The igniter supply was turned on, and breakdown would often occur between 600V and 800 V. The igniter could support a 0.5 A discharge at approximately 400 V. The 18 A power supply was then turned on and a discharge of 15 A at approximately 100 V was established. The igniter was turned off and flow rate increased to 140 mg/s. At that point, a 15 A discharge of approximately 180 V was attained. Current from the main power supply was slowly increased to 40 A. Following this, propellant flow and arc current were both increased until the required operating point was established. The current was periodically adjusted to maintain constant power as the thruster voltage approached a steady state level.

Power and flow rate were held constant for 20 minutes at each operating point to establish thermal equilibrium before final thrust measurements were recorded. After a final set of data had been taken the arc was extinguished, however propellant was allowed to flow for one additional minute so that convectively-heated thrust could be measured. After propellant flow was shut off an updated thrust zero was established by which the previous thrust measurement would be referenced. While negligible in most instances, the largest zero drift correction was no more than 1% full scale thrust. Cycling of the thrust stand calibration weights was regularly performed within 3 minutes of every test run. No changes in thrust stand sensitivity were observed.

RESULTS AND DISCUSSION

To be consistent with 1960's results, thrust efficiencies throughout this paper were calculated as the ratio of thrust kinetic power divided by electrical input power, as determined by the equation:

$$\eta = \frac{T^2}{2m\bar{I}\bar{V}} \quad (1)$$

where T is corrected thrust, m is mass flow, \bar{I} and \bar{V} are average current and voltage values, respectively. The enthalpy of incoming propellant was ignored.

Testing of Radiation Cooled Arcjet

For an initial cold flow test, hydrogen was adjusted to a rate of 152 mg/s, which was half the maximum capacity of the main flow controller. A thrust of 390 mN was initially observed, but as flow continued over the next 5 minutes this value gradually decreased. When the facility background pressure stabilized at 51 Pa (0.39 torr), thrust steadied out at 360 mN and cold flow specific impulse was determined to be 245 s. A similar effect was noted at the maximum flow rate, when cold flow specific impulse gradually dropped to a value of 239 s as

facility background pressure increased to 135 Pa (1.02 torr). The cold flow specific impulse not only fell short of the theoretical room temperature value of 297 s, but became worse at higher flow rates.

A simple exit area, background pressure correction was performed on the cold flow thrust data. Corrected specific impulses of 262 s and 261 s were determined for flow rates of 153 and 301 mg/s respectively. The highest propellant flow rate tested with this thruster was 348 mg/s, which resulted in a facility background pressure of 152 Pa (1.14 torr). The thrust correction at this pressure was 72 mN. Viscous effects and under expansion of exhaust gases may account for additional specific impulse losses, however estimation of these is beyond the scope of this work.

Upon establishing an arc, the first powered operation of the thruster occurred at flow rate of 268 mg/s and power level of 30 kW, the original design point of the GSC thruster. A bright, luminous plume was emitted by the thruster, similar to that seen with conventional arcjets. The thruster ran smoothly at the design point, where a power level of 30 kW was reached with an average voltage of 222 V and current of 137 A. This voltage, however, was much higher than is commonly experienced with conventionally constricted arcs.

A digital oscilloscope was used to observe both voltage and current waveforms. The power supply inductor was effective at limiting current ripple to about 1%. The voltage, however, varied in a sawtooth fashion between 100 and 310 V at a frequency of approximately 24 kHz (Fig. 6). A low pass signal filter was added to the voltmeter to ensure that indicated average arc voltage was not biased by the unusual waveform. Since arc current ripple was very low, arc power was determined by the product of indicated current and average voltage.

The original GSC report³ briefly mentioned voltage fluctuations which ranged in frequency from 15 to 25 kHz, in rough agreement with those in Figure 6. A similar phenomenon was observed by Sankovic¹³ and Berns¹⁴ involving recent low-power, subsonic-arc-attachment tests. An arc restrike behavior was discussed, in which counteracting gas dynamic and magnetic forces contort the arc column and force oscillatory characteristics within the arc chamber. Although not certain, cyclic extension and truncation of the arc column would be consistent with the voltage waveform observed during operation.

At the design point flow rate and power level, a steady state thrust of 2448 mN was measured. The facility background pressure was 119 Pa (0.89 torr) and nearly identical to 120 Pa (0.9 torr) observed in the original GSC report.³ Thrust corrected for back pressure was 2505 mN, which is 4.7% below that obtained by GSC at the design point. Specific impulse was determined to be 953 s at an efficiency of 0.39. The performance obtained here was below the specific impulse of 1000 s and thrust efficiency of 0.43 reported in the early GSC work. The lower performance may, in part, be due to the reduced exit area of

this nozzle (see next section). These differences are summarized in Tables I and II. (The GSC report provided power level but, neither voltage nor current).

After the thruster had reached steady state operation and hot thrust data were taken, the arc was extinguished, but propellant flow was maintained for one minute. The propellant was convectively heated by the hot components internal to the arcjet thruster and expanded out the nozzle to produce thrust. The convectively-heated thrust data could then be compared with the arc-heated data at the same flow rate, revealing regenerative characteristics of the design. With an anode temperature of 1793 °C at the moment of arc termination, a convectively-heated specific impulse of 531 s was measured. Direct arc heating of the gas had supplied the additional 422 s of Isp during hot operation. Even though this thruster was built as a radiation-cooled design, it displayed strong regenerative characteristics.

The thruster was tested over a wide range of power levels and flow rates to determine its sensitivity to off design conditions. Specific powers ranged from 61 MJ/kg to 177 MJ/kg. Operation at lower specific powers often resulted in voltage fluctuations and plume instability. The nozzle temperature increased with specific power, and there was concern that anode melting might occur at higher values. Data obtained are listed in Table III and corresponding performance are shown in Figure 7. Specific impulse is plotted as a function of specific power over a range bounded by arc stability at the low end, and nozzle temperature at the high end. Both arc-heated and convectively-heated specific impulse values are plotted to illustrate the regenerative characteristics of this radiation-cooled thruster. The ratio of convective thrust to total thrust varied from 58% at low specific powers to about 55% at higher specific powers. It might be expected that the regenerative contribution would decline as radiant losses from the anode become significant. In such a situation, direct arc heating of the gas would become the dominant mode of energy addition.

Data derived from the GSC report³ are listed in Table IV for various propellant flow rates. A comparison of performance data between Tables III and IV is plotted in Figure 8, which shows thrust efficiency as a function of Isp. The highest specific impulse obtained in these tests was 1094 s, at a thrust efficiency of 0.32. The highest thrust efficiency obtained was 0.42, at a specific impulse of 727 s. It can be seen that at the design specific impulse of 1000s, the thrust efficiency was about 0.07 less than the 1964 data.

GSC tested model 141-300 at specific powers up to 370 MJ/kg. The maximum specific Impulse obtained in the original work was 1448 s, but corresponding thrust efficiency had fallen to levels comparable to that of conventionally constricted arcjet thrusters. Because this point of operation was far from the original design point, obtaining data at this level was not viewed to be worth possible hardware damage.

One possible cause for the lower performance seen in these tests may be the reduced exit diameter of the nozzle. The nozzle exit to throat area ratio of this thruster was 27:1, as compared to the original ratio of 56:1. As discussed in the next section, cold flow thrust measurements taken with a 60:1 area ratio nozzle were substantially above those obtained with the 27:1 area ratio nozzle of the radiation-cooled thruster.

Testing of Regeneratively-Cooled Arcjet

Propellant to the regenerative arcjet was normally divided according to a 93% main and 7% secondary flow split. This ratio was specified in the GSC reports and was originally arrived at out of concern for thruster life. In the interest of following GSC procedure, this ratio was followed whenever practical. As with the radiation-cooled design, testing of the regenerative arcjet thruster began with cold flow thrust measurements. For purposes of simplicity, initial cold flow tests were performed with propellant supplied to the main inlet only. No flow was supplied to the secondary feed line, although static pressure within the arc chamber was monitored through this inlet. At a flow rate of 302 mg/s, arc chamber pressure rose to 27.8 kPa (4.03 psia), and a cold flow thrust of 699.8 mN was measured. Because the exit area of this thruster was larger than the radiation-cooled design, a larger back pressure thrust correction was used. At a background pressure of 97 Pa (0.73 torr), the corrected cold gas thrust was 803 mN. This corresponds to 271 seconds of specific impulse, which is about 3.8 % higher than the cold flow specific impulse obtained with the radiation-cooled thruster. This value matches almost exactly the cold flow Isp of 270 s reported by GSC. The higher cold flow Isp of the regenerative thruster may be attributed to the larger 60:1 area ratio of this device. If such a difference also occurs during normal arc heated operation, it may explain much of the 4.7% thrust shortfall seen with the radiation-cooled thruster at design point conditions (Table II).

As with the radiation-cooled design, the first powered operation of this thruster was an attempt to reproduce the original regenerative GSC design point. Figure 9 shows the regeneratively-cooled arcjet operating at 30 kW with a combined primary and secondary propellant flow rate of 333 mg/s. The collimated plume was characteristic of arcjet operation in the facility at background pressures on the order of 130 Pa (1.0 torr).

Figures 10(a), 10(b), and 10(c) show voltage and current traces of the thruster at specific powers of 75, 91, and 112 MJ/kg, respectively. As with the radiation-cooled thruster, the regenerative version exhibited high-frequency voltage ripple at all points of operation. The regenerative thruster waveforms, however, were noticeably more regular than those of the radiative thruster. While the arc current was almost constant, instantaneous arc voltage typically oscillated between 90 and 310 V. Near the design point, waveform frequency was about 19 kHz. Arc voltage

waveforms very similar to those shown in Figures 10(a) through 10(c) are illustrated in both the GSC³ and McDonnell⁵ reports. GSC reported a frequency of almost 25 kHz at 30 kW, but also saw frequencies as low as 15 kHz at some operating points.

The regenerative arcjet thruster was operated for 20 minutes in an attempt to reach the designed power level of 30 kW. Average arc voltage gradually increased until it leveled off at 218 V. The electrical current capability of the facility, however, was limited to 134 A and arc power fell slightly short of 30 kW. By reducing propellant flow, the same specific power of 90 MJ/kg was achieved. With an input power of 29.2 kW and flow rate of 323 mg/s, the measured thrust was 2840 mN. To account for the background pressure of 93 Pa (0.70 torr), the thrust was corrected to 2940 mN, resulting in a specific impulse of 927 s and efficiency of 0.46. At the design point, GSC measured a specific impulse of 1000 s and thrust efficiency of 0.53. While the recent test point was obtained at a slightly reduced power and flow rate, a 7.3% drop in specific impulse was not expected. In a subsequent test with higher current capability, the power and flow rate were matched exactly to the original design point conditions, but there was no improvement in performance (see Table II).

After steady state thrust measurements were obtained, the arc was extinguished in order to determine regenerative characteristics of the thruster. The convectively-heated propellant yielded a specific impulse of 593 s, which corresponded to 64% of the full power thrust. While the maximum external body temperature of the thruster was 822 °C, internal components were likely to have been much hotter. By comparison, the maximum convective Isp obtained with the radiation-cooled thruster was 599 s. While the radiative thruster was operated at 177 MJ/kg, the regenerative thruster was operated at only 91 MJ/kg but achieved almost the same convective Isp.

To explore other modes of operation and map out performance, the thruster was run at power to mass flow rates ranging from 54 MJ/kg to 112 MJ/kg. The resulting data are listed in Table V and displayed in Figure 11. As with the radiation-cooled thruster, voltage and plume fluctuations occurred at the lowest specific power levels. Thruster temperatures increased with increasing specific power level until concern for a braze joint ultimately limited hot thruster operation. The operating range of specific power was limited by stability at the low end and thruster temperatures at the high end. Both arc-heated and convectively-heated values of specific impulse are shown to illustrate the regenerative characteristics of this thruster. The convectively-heated thrusters were consistently about 64% of the full power values, with 643 s being the highest specific impulse measured after the arc was extinguished.

Older data derived from the original GSC report³ are listed in Table VI. While thruster performance data were available, very limited voltage-current data were found. Electrical input recorded during a 500 hour endurance test showed average voltages to randomly drift

between 210 V and 275 V, even while constant power and flow rate were maintained.

Performance data from Tables V and VI are plotted in Figure 12 which shows thrust efficiency as a function of specific impulse. The highest thrust efficiency obtained was 0.47, at a specific impulse of 777 s and specific power of 61 MJ/kg. At lower specific powers, operation was marginally stable and the efficiency was slightly less. The highest specific impulse achieved with the regeneratively-cooled thruster was 1001 s, at a thrust efficiency of 0.43. This specific impulse was obtained at a thruster body temperature of 1082 °C. The fact that temperatures of this magnitude occurred on the outer housing surface indicates that thermal containment within the thruster was not as effective as might be desired. The thermal design could be improved with additional heat shielding around the arc chamber and incorporation of thermal breaks within the thruster. Details of this nature were not described in the GSC reports and therefore not included in the recently fabricated thruster.

The original GSC model 141-400 thruster was run at specific powers up to 176 MJ/kg. A maximum specific impulse of 1251 s was reported, with a corresponding thrust efficiency of 0.44. At this high energy level, however, the regeneratively-cooled thruster held only a 0.06 efficiency advantage over the radiation-cooled model 141-300.

CONCLUDING REMARKS

Two 30 kW hydrogen arcjets were recently built and tested, based on designs originally developed by the Giannini Scientific Corp. in 1963. A radiation-cooled arcjet was built similar to GSC model 141-300, while a regeneratively-cooled version was a close replica of model 141-400.

Even though the arc column in these thrusters supposedly seated upstream of the nozzle throat, a luminous plume was clearly noted in the exhaust of both thrusters, similar to that observed with conventionally constricted arcjets. The arc voltages, however, were much higher than typically observed with conventionally constricted arcjet designs. Average voltages ranged from 188V to 248V, depending on current and propellant mass flow rate. While thruster current was steady, instantaneous voltage resembled a sawtooth waveform, oscillating from 100V to 310 V, at frequencies on the order of 20 kHz.

Thrust measurements were taken on a thrust stand under a wide range of conditions. As with the original GSC data, thrust measurements were corrected for background pressure effects. When operated at design point conditions, a specific impulse of 953 s at 0.39 efficiency was measured with the radiation-cooled thruster. The original report listed a performance of 1000 s at 0.43 efficiency. While this corresponds to a 4.7% decrease in thrust compared to the GSC reported data, the area ratio of the GSC device was nearly twice that of the thruster tested

in this study. Although not certain, losses resulting from under expansion of exhaust gases may account for the lower performance obtained in recent tests. This explanation is supported by cold flow thrust data which showed a 3.8% thrust penalty for the smaller area ratio nozzle.

When the regeneratively-cooled thruster was operated at design point conditions, it obtained a specific impulse of 925 s at an efficiency of 0.45. The original report listed a performance of 1000 s at 0.53 efficiency. Because the geometry and operating point of both thrusters were nearly identical, the reason for the difference in performance is not known. It is possible that design subtleties in the original thruster were not included in the recently fabricated version, and that these differences account for the reduction in performance. While the performance discrepancies between this work and the 1960's report are sizable, there may be opportunities for improvement of the recently built device through refinement of the thermal design.

REFERENCES

1. Wallner, L.E. and Czika, J. Jr., "Arc-jet Thrusters for Space Propulsion," NASA TN D-2868, June 1965.
2. John, R.R., "Thirty Kilowatt Plasmajet Rocket Engine Development," RAD-SR-64-168, Avco Corp., Wilmington, MA, 1964.
3. Todd, J.P., "30 kW Arcjet Thruster Research," APL-TDR-64-58, Giannini Scientific Corp., Santa Ana, CA, March 1964. (Avail. NTIS AD-601534).
4. Todd, J.P. and Sheets, R. E., "Development of a Regeneratively Cooled 30-kW Arcjet Engine," AIAA Journal, Vol. 3 No. 1, pp. 122-126, 1965.
5. Van Camp, W.M., et. al., "Study of Arc-Jet Propulsion Devices," McDonnell Report E368, (NASA CR-5491), March 1966.
6. Rosen, S.G. and Sloan, J. H., "Electric Orbit Transfer Vehicle- A Military Perspective," AIAA Paper 89-2496, July 1989.
7. Pivrotto, T.J., et al., "The Design and Operating Characteristics of a 30 KW Thermal Arcjet Engine for Space Propulsion," AIAA Paper 86-1508, June 1986.
8. Schuster, J.R., "Feasibility of Applying Centaur Technology to an EOTV Propellant Storage and Management System," Final Report, General Dynamics Corp., NAS3-25972, July 1992.
9. Miller, T.M., "Parametric Cost Analysis of an Operational EOTV," Proceedings of the 1992 JANNAF Propulsion Meeting, February 1992.
10. "H2 Arcjet Performance Mapping Program," Final Report, Rocket Research Corp., NASA CR-191073, January 1992.
11. Haag, T.H. and Curran, F.M., "High-Power Hydrogen Arcjet Performance," AIAA 91-2226, June 1991. (NASA TM 105143)
12. Hamley, J.A., et al., "10 kW Power Electronics for Hydrogen Arcjets," Proceedings of the 1992 JANNAF Propulsion Meeting, (also NASA TM105614), February 1992.
13. Sankovic, J.M. and Berns, D.H., "Performance of a Low-Power Subsonic-Arc-Attachment Arcjet Thruster," AIAA 93-1898, June 1993.
14. Berns, D.H., et al., "Investigation of a Subsonic-Arc-Attachment Thruster Using Segmented Anodes," AIAA 93-1899, June 1993.

Table I. - Anode dimensions, diameter in mm [3,5]

Thruster	Arc chamber entrance	Arc chamber	Nozzle throat	Nozzle exit plane
Giannini 141-300 (1964)	6.35	6.35	4.75	35.5
Radiation-cooled (1993)	6.35	6.35	4.75	24.6
Giannini 141-400 (1964)	6.35	7.92	4.75	36.8
Regen-cooled (1993)	6.35	7.92	4.75	36.8

Table II. - Performance at design point conditions [3]

Thruster	Mass flow mg/s	Power kW	Thrust mN	Isp s	Thrust efficiency
Giannini 141-300 (1964)	268	30.0	2628	1000	0.430
Radiation-cooled (1993)	268	30.4	2505	953	0.385
Giannini 141-400 (1964)	333	30.0	3264	1000	0.534
Regen-cooled (1993)	333	30.2	3017	925	0.454

Table III. - Performance of radiation-cooled arcjet

H ₂ flow rate, mg/s	Arc voltage, V	Arc current, A	Arc power, kW	Specific power, MJ/kg	Arc heated thrust, mN (corrected)	Arc heated Isp, s	Thrust efficiency	Facility pressure, Pa	Thruster temperature C	Convective thrust, mN (corrected)	Convective Isp, s
153	0.0	0.0	0.00	0	391	261	-	51	23	391	261
302	0.0	0.0	0.00	0	771	261	-	135	23	771	261
168	188.4	157.6	29.69	177	1785	1084	0.320	66	1999	987	599
186	196.2	155.3	30.47	164	1946	1065	0.334	74	1958	1060	580
213	207.0	155.3	32.15	151	2204	1055	0.355	87	1924	1185	567
243	214.5	152.0	32.60	134	2398	1006	0.363	99	1889	1314	551
268	222.5	135.1	30.06	112	2474	941	0.380	111	1788	1384	527
268	222.3	136.8	30.41	114	2505	953	0.385	119	1793	1398	532
268	223.0	144.5	32.22	120	2551	971	0.377	112	1831	1401	533
324	227.7	86.3	19.65	61	2310	727	0.419	140	-	1431	450
333	231.0	130.2	30.08	90	2830	867	0.400	142	1665	1606	492
348	233.0	112.0	26.10	75	2745	804	0.415	152	1509	1600	469

Table IV. - Performance of Giannini model 141-300 [3]

H ₂ flow rate, mg/s	Arc power, kW	Specific power, MJ/kg	Corrected thrust, mN	Specific impulse, s	Thrust efficiency
81	30	370	1151	1448	0.272
109	30	274	1459	1361	0.325
145	30	207	1808	1270	0.375
268	30	112	2628	1000	0.430

Table V. - Performance of regeneratively-cooled arcjet

H ₂ flow rate, mg/s	Arc voltage, V	Arc current, A	Arc power, kW	Specific power, MJ/kg	Arc heated thrust, mN (corrected)	Arc heated Isp, s	Thrust efficiency	Facility pressure, Pa	Thruster temperature C	Convective thrust, mN (corrected)	Convective Isp, s
302	0.0	0.0	0.00	0	803	271	-	97	23	803	271
302	0.0	0.0	0.00	0	809	274	-	105	23	809	274
302	0.0	0.0	0.00	0	820	277	-	121	23	820	277
182	195.7	90.1	17.63	97	1654	927	0.427	51	1043	1101	617
256	213.0	122.7	26.14	102	2452	978	0.450	73	1029	1576	628
268	213.8	140.9	30.12	112	2630	1001	0.429	116	1082	1689	643
295	208.3	156.0	32.49	110	2887	998	0.435	122	1041	1825	631
321	213.0	156.1	33.25	104	3061	972	0.439	144	938	1958	622
323	218.5	133.8	29.24	90	2940	927	0.457	93	822	1880	593
324	248.0	70.1	17.38	54	2300	724	0.470	136	364	-	-
324	242.0	82.3	19.92	61	2469	777	0.472	136	440	-	-
333	216.0	139.5	30.13	91	2995	918	0.448	154	-	1913	586
333	217.7	138.6	30.17	91	3017	925	0.454	138	785	-	-
334	241.9	78.7	19.04	57	2400	733	0.453	141	411	1535	469
348	231.6	113.1	26.19	75	2916	854	0.466	148	610	1854	543
348	227.3	126.8	28.82	83	3034	889	0.459	161	708	1930	565
348	213.8	155.5	33.25	96	3209	940	0.445	146	850	2018	591

Table VI. - Performance of Giannini model 141-400 [3]

H ₂ flow rate, mg/s	Arc power, kW	Specific power, MJ/kg	Corrected thrust, mN	Specific impulse, s	Thrust efficiency
177	30	170	2169	1252	0.444
250	30	120	2758	1127	0.508
333	30	90	3264	1000	0.534

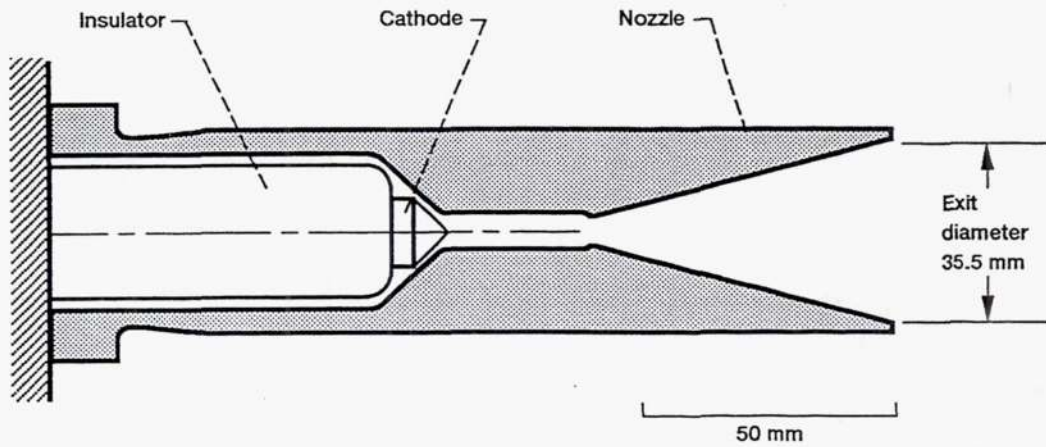

(a) Model 141-300 radiation cooled arcjet.

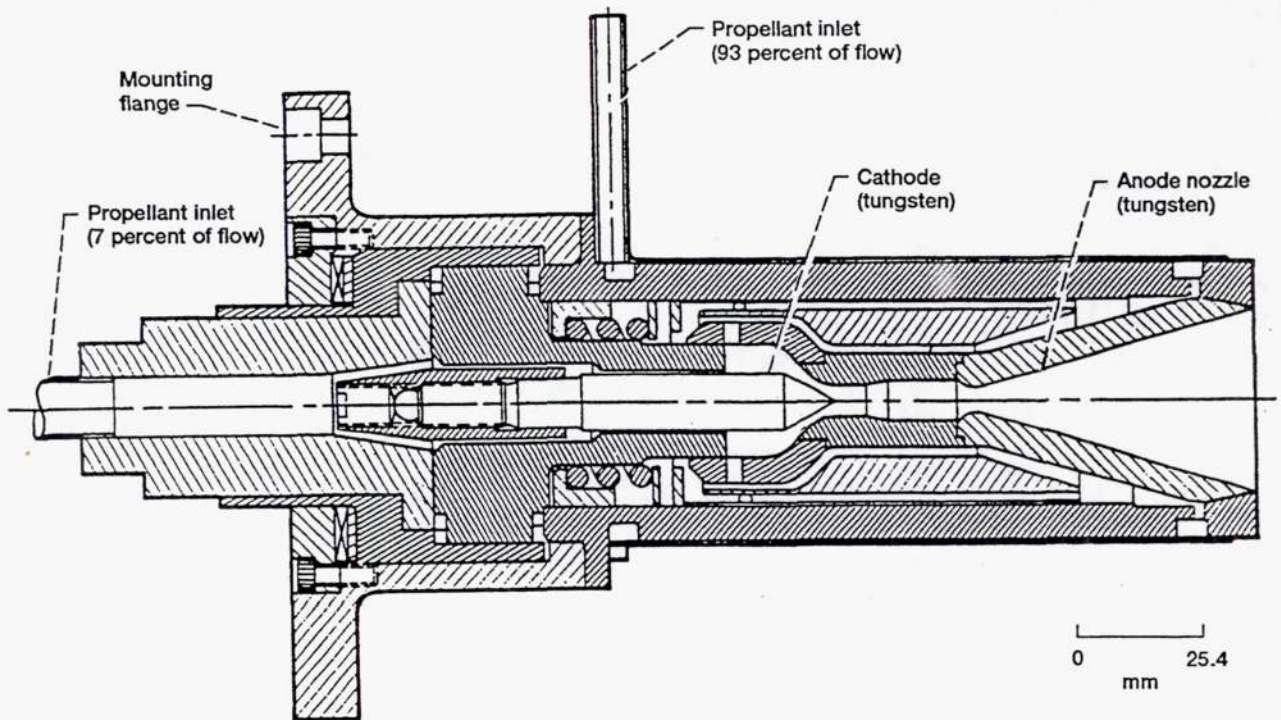

(b) Model 141-400 regeneratively cooled arcjet.

Figure 1.—Giannini thruster designs from 1960's.

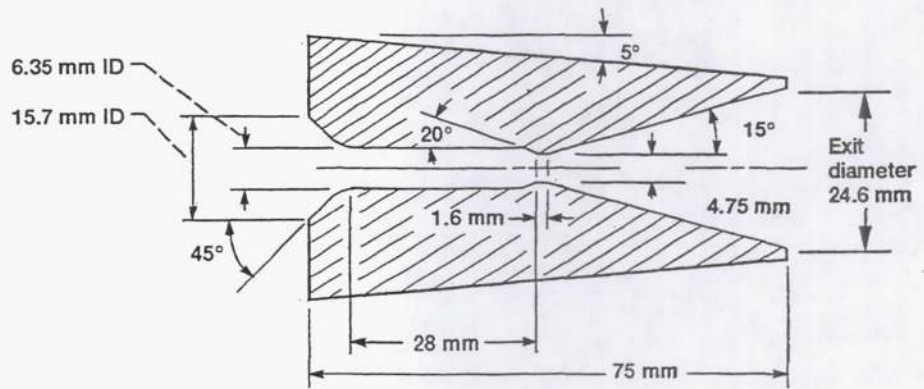

(a) Nozzle detail.

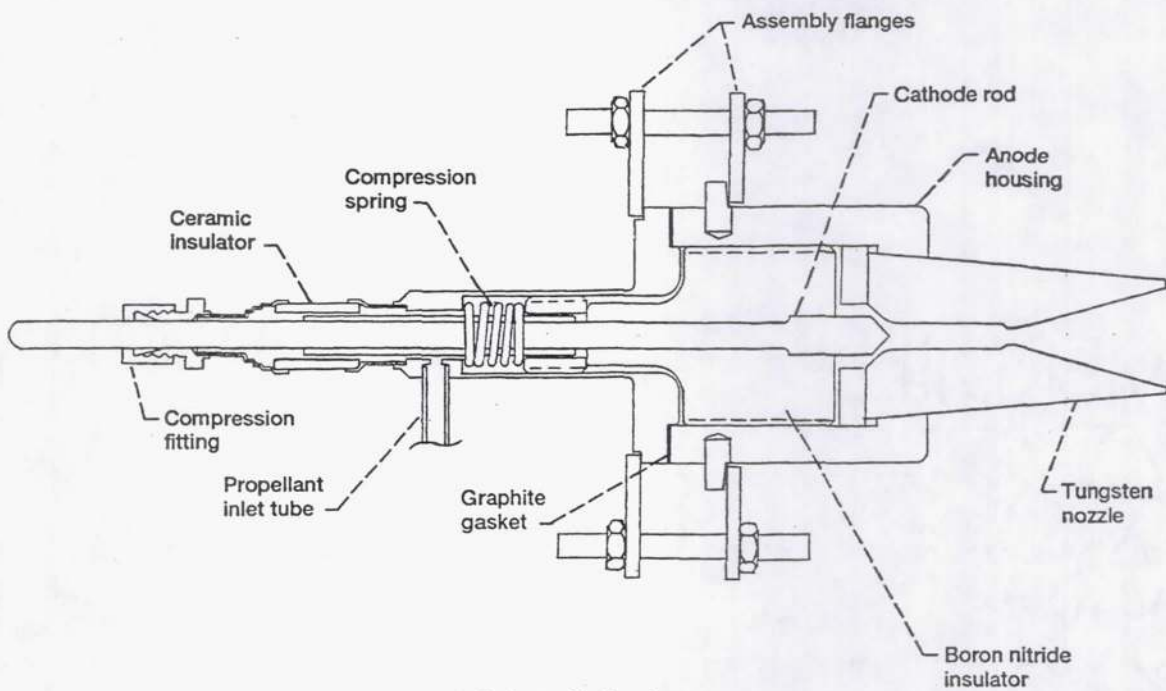

(b) Assembled arcjet.

Figure 2.—Radiation cooled arcjet used for testing Giannini type electrode geometry.

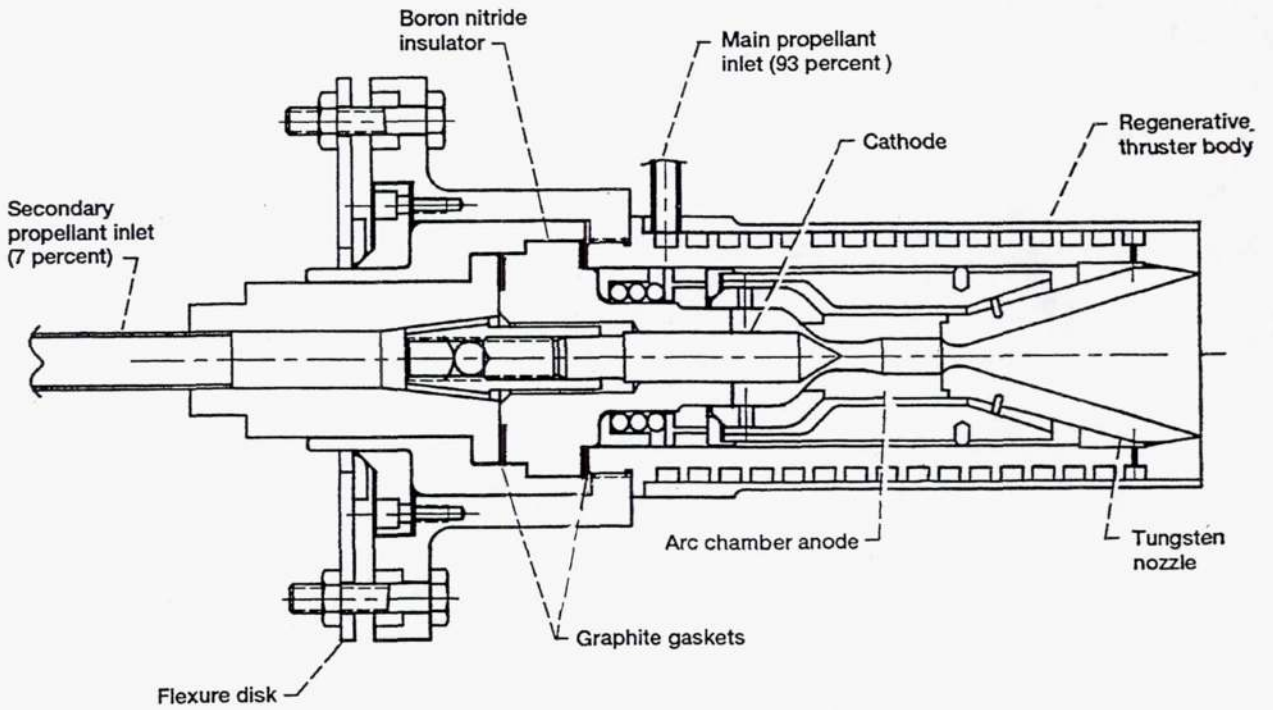

Figure 3.—Regeneratively cooled arcjet thruster based on Giannini design.

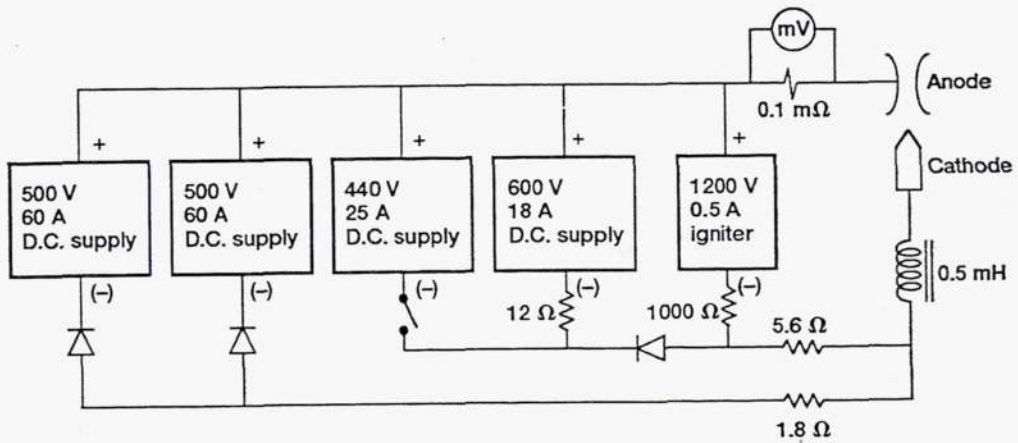
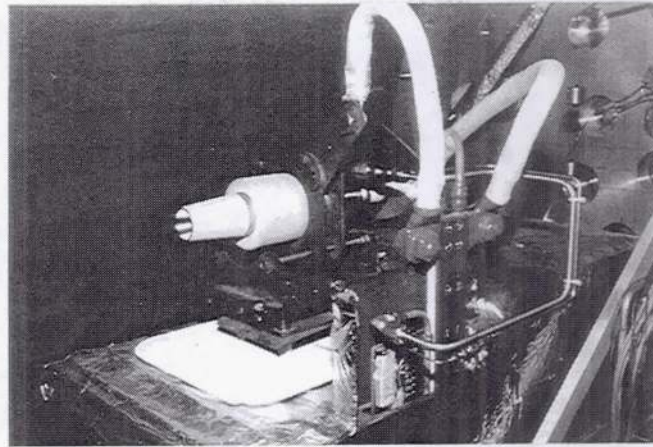
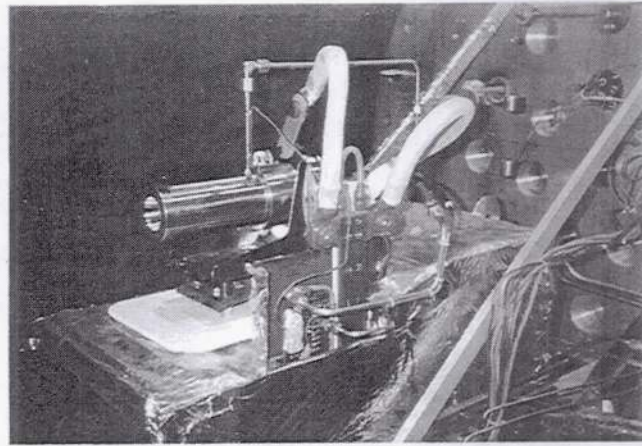

Figure 4.—Arcjet power supply schematic.



(a) Radiation cooled.



(b) Regeneratively cooled.

Figure 5.—Arcjet thruster mounted on thrust stand.

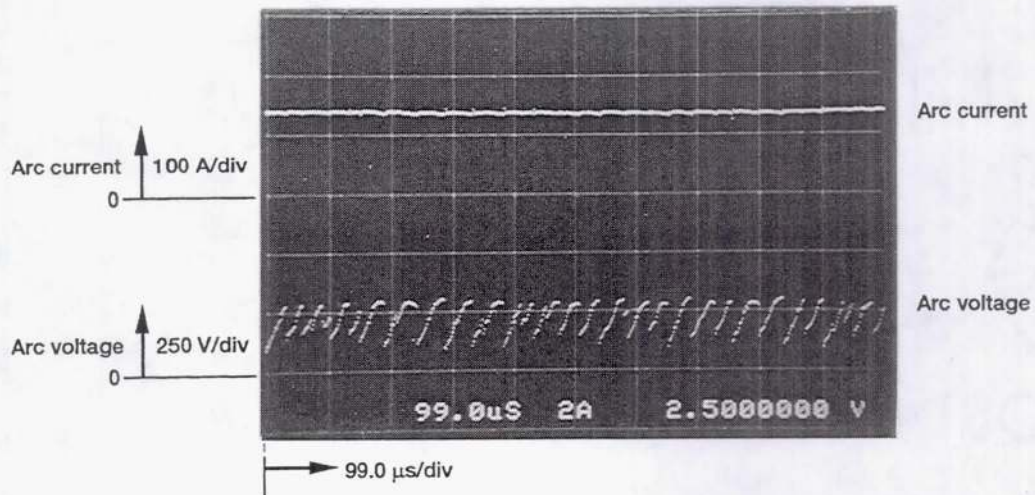

Figure 6.—Voltage and current wave forms of radiation cooled arcjet operating at design point conditions (30 kW input power, 268 mg/s H_2 , frequency = 24 kHz).

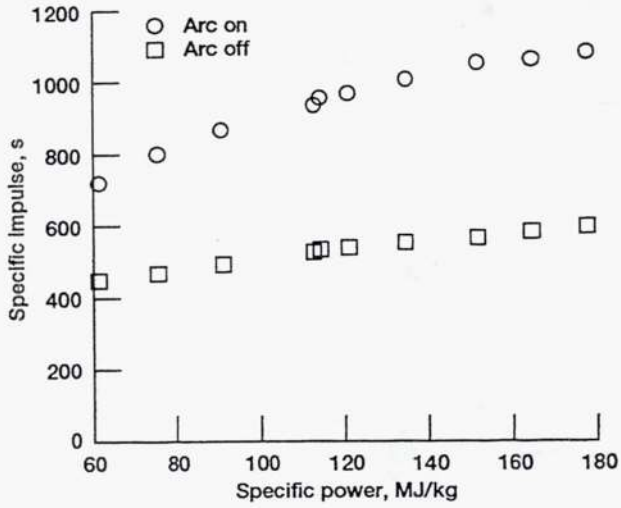

Figure 7.—Specific impulse of radiation cooled arcjet as a function of specific power.

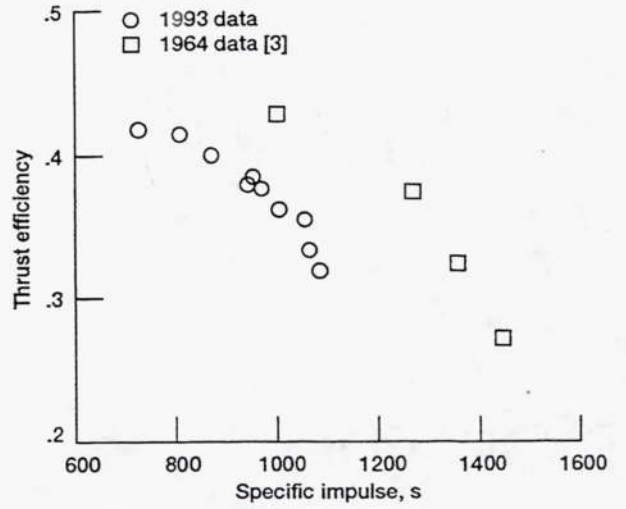

Figure 8.—Thrust efficiency of radiation cooled arcjet as a function of specific impulse.

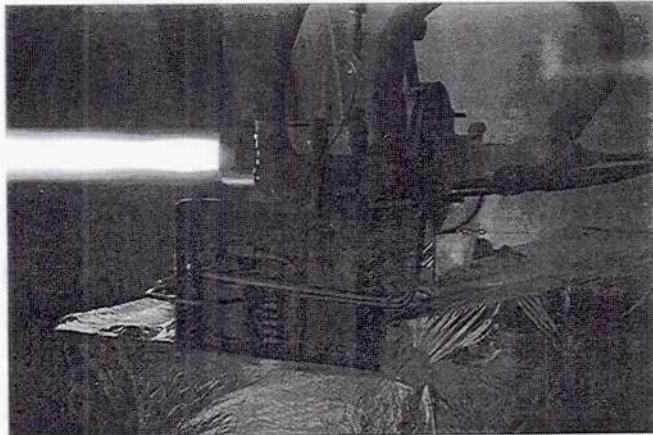
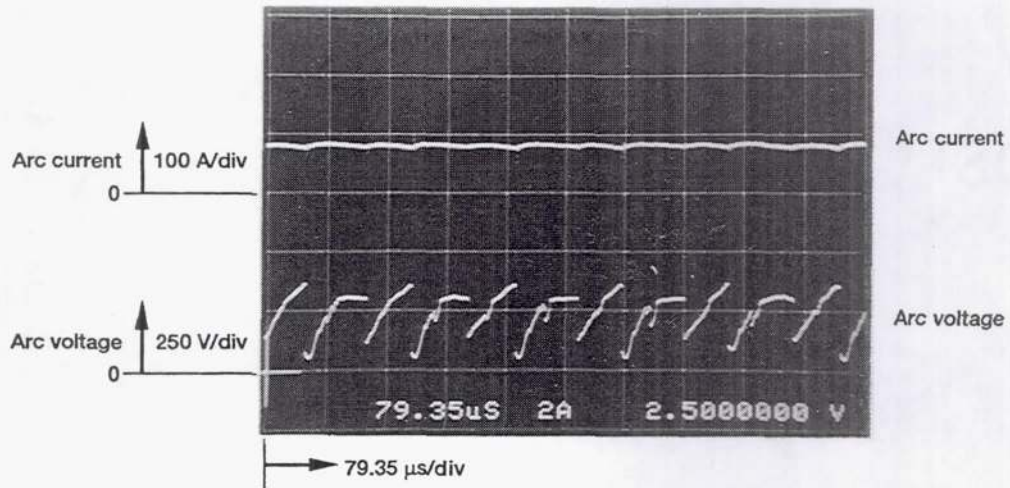
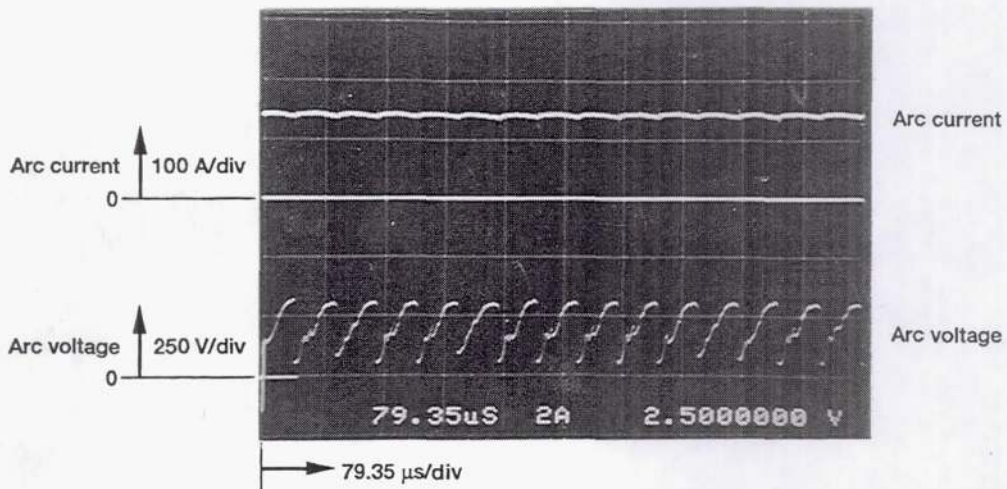

Figure 9.—Regeneratively cooled arcjet thruster operating at design point conditions.



(a) Operation at 75 MJ/kg, frequency = 14 kHz.



(b) Operation at 91 MJ/kg, frequency = 19 kHz.

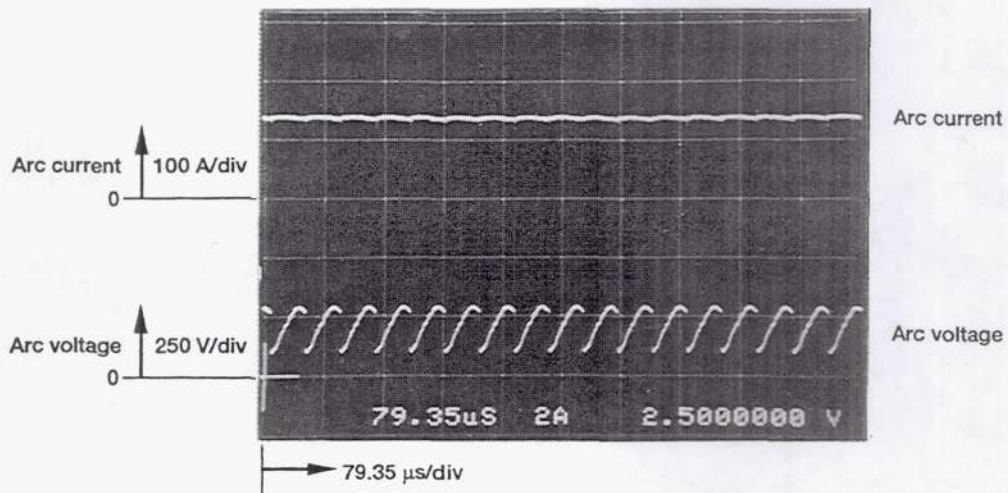

(c) Operation at 112 MJ/kg, frequency = 21 kHz.

Figure 10.—Voltage and current wave forms of regeneratively cooled arcjet.

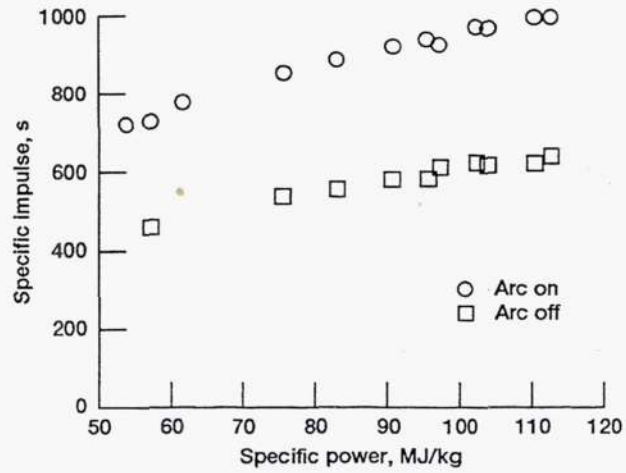

Figure 11.—Specific impulse of regeneratively cooled arcjet as a function of specific power.

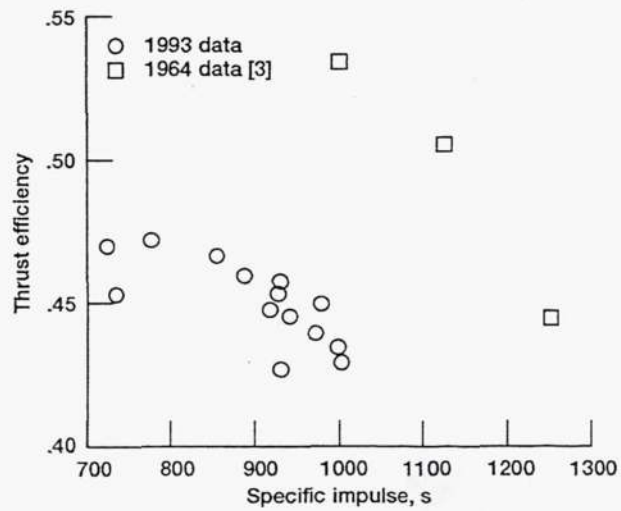

Figure 12.—Thrust efficiency of regeneratively cooled arcjet as a function of specific impulse.

REPORT DOCUMENTATION PAGE

Form Approved
OMB No. 0704-0188

Public reporting burden for this collection of information is estimated to average 1 hour per response, including the time for reviewing instructions, searching existing data sources, gathering and maintaining the data needed, and completing and reviewing the collection of information. Send comments regarding this burden estimate or any other aspect of this collection of information, including suggestions for reducing this burden, to Washington Headquarters Services, Directorate for Information Operations and Reports, 1215 Jefferson Davis Highway, Suite 1204, Arlington, VA 22202-4302, and to the Office of Management and Budget, Paperwork Reduction Project (0704-0188), Washington, DC 20503.

1. AGENCY USE ONLY (Leave blank)	2. REPORT DATE June 1993	3. REPORT TYPE AND DATES COVERED Technical Memorandum	
4. TITLE AND SUBTITLE Recent Testing of 30 kW Hydrogen Arcjet Thrusters		5. FUNDING NUMBERS WU-506-42-31	
6. AUTHOR(S) Thomas W. Haag		8. PERFORMING ORGANIZATION REPORT NUMBER E-7923	
7. PERFORMING ORGANIZATION NAME(S) AND ADDRESS(ES) National Aeronautics and Space Administration Lewis Research Center Cleveland, Ohio 44135-3191		10. SPONSORING/MONITORING AGENCY REPORT NUMBER NASA TM-106214 AIAA-93-1902	
9. SPONSORING/MONITORING AGENCY NAME(S) AND ADDRESS(ES) National Aeronautics and Space Administration Washington, D.C. 20546-0001		11. SUPPLEMENTARY NOTES Prepared for the 29th Joint Propulsion Conference and Exhibit cosponsored by the AIAA, SAE, ASME, and ASEE, Monterey, California, June 28-July 1, 1993. Responsible person, Thomas W. Haag, (216) 977-7423.	
12a. DISTRIBUTION/AVAILABILITY STATEMENT Unclassified - Unlimited Subject Category 20		12b. DISTRIBUTION CODE	
13. ABSTRACT (Maximum 200 words) NASA is conducting efforts to evaluate high-power hydrogen arcjets for orbit transfer propulsion applications. As part of this program, an attempt was made to reexamine both radiatively- and regeneratively-cooled, 30 kW thrusters first demonstrated by the Giannini Scientific Corp. in 1963. The arcjets were configured to force arc attachment upstream of the throat in a subsonic chamber region. While thruster currents were steady, the voltage traces exhibited sawtooth waveforms at frequencies on the order of 20 kHz. Voltage variations per cycle were typically between 100 and 310 volts, indicating major changes in the position of the arc attachment with time. When operated at their respective design points, the performance of both thrusters fell below the values listed in the 1960's development reports. The reason for the discrepancies is not currently understood and further investigations are in progress. However, the recently measured efficiencies were high compared to those obtained with constricted-arc designs at similar conditions, and further arcjet performance optimizations may be possible.			
14. SUBJECT TERMS Arcjet; Electric propulsion; Electro thermal			15. NUMBER OF PAGES 19
17. SECURITY CLASSIFICATION OF REPORT Unclassified			16. PRICE CODE A03
18. SECURITY CLASSIFICATION OF THIS PAGE Unclassified	19. SECURITY CLASSIFICATION OF ABSTRACT Unclassified	20. LIMITATION OF ABSTRACT	