

---

## Reconfigurable manufacturing systems and their enabling technologies

---

Mostafa G. Mehrabi, A.Galip Ulsoy and Yoram Koren

Department of Mechanical Engineering and Applied Mechanics, The University of Michigan, Ann Arbor, MI 48109-2125, USA

E-mail: {mosais, ulsoy, ykoren}@engin.umich.edu

**Abstract:** A reconfigurable manufacturing system (RMS) is designed for rapid adjustment of production capacity and functionality in response to new market conditions and new process technology. It has several distinct characteristics including modularity, integrability, customization, convertibility and diagnosability. There are a number of key interrelated technologies that should be developed and implemented to achieve these characteristics. This paper examines and identifies these technologies. After a brief description of the RMSs and their goals, aspects of reconfiguration (reconfigurable system, software, controller, machine, and process) are explained; this provides one with a better understanding of the enabling technologies of RMSs. Some of the issues related to the technology requirements of RMSs at the system and machine design levels, and ramp-up time reduction are then explained. The paper concludes with descriptions of some of the future research directions for RMSs.

**Keywords:** agility; manufacturing strategy; market change.

**Reference** to this paper should be made as follows: Mehrabi, M.G., Ulsoy, A.G. and Koren, Y. (2000) 'Reconfigurable manufacturing systems and their enabling technologies', *Int. J. Manufacturing Technology and Management*, Vol. 1, No. 1, pp. 114–131.

**Biographical notes:** Mostafa G. Mehrabi is a faculty member in Mechanical Engineering and Applied Mechanics at the University of Michigan, Ann Arbor. He received his PhD from Concordia University (Canada) in Mechanical Engineering. His research interests include advanced manufacturing, computer control of manufacturing systems, computer integrated manufacturing, mechatronics, automation of production systems (hardware and software), analysis, design and implementation of industrial control systems, and CNC machine tools control and monitoring systems. In 1996 he was the winner of the Natural Sciences and Engineering Research Council of Canada (NSERC) award for outstanding research achievements. He has served as reviewer for several technical journals and conferences including *IEEE/ASME Transactions on Mechatronics*, *ASME Journal of Manufacturing Science and Engineering*, *IEEE Transaction on Control Systems Technology*, *Transactions of the Society of Manufacturing Engineers (SME)*, IEEE Conferences, and ASME Conferences.

Galip Ulsoy is the William Clay Ford Professor of Manufacturing and Chair of the Dept. of Mechanical Engineering and Applied Mechanics (MEAM) at the University of Michigan. He received his PhD from the University of California–Berkeley. His research interests include dynamics and control including computer control, rotating or translating elastic systems, manufacturing automation, vehicle control, adaptive control of machine tools and tool wear estimation. He is the Technical Editor of the *ASME J. Dynamic Systems, Measurement and Control*, and an editorial board member for *Mechanical Systems and Signal Processing*. He

has received several awards including Outstanding Young Manufacturing Engineer in 1986 and the American Control Conference, Best Presentation Award in 1995.

Yoram Koren is the Paul G. Goebel Professor of Engineering and Director of the Centre for Reconfigurable Machining Systems at the University of Michigan, Ann Arbor. He received his PhD in Mechanical Engineering from the Technion Institute in Israel. His pioneering research on real-time interpolation and control methodologies paved the way for the creation of machine tool control as a research field and an education discipline. His novel adaptive control techniques for turning and grinding were implemented in the late 1970s by industry and are often quoted in the professional literature. Professor Koren has published three books in the automated manufacturing field which have been translated into Japanese, French and Chinese and have won prestigious awards. He is a Fellow of both ASME and SME, a Senior Member of IEEE, and chairs the CIRP Scientific Technical Committee for Machines and Controls.

---

## 1 Introduction

New technological developments and market demands have major impacts on manufacturing. As a result, several shifts in focus of manufacturing processes can be observed; they can be conveniently divided into three major epochs: 1) pre-computer numerical control, 2) computer numerical control (CNC), and 3) knowledge epochs [1,2]. In the pre-CNC epochs (before the 1970s), the emphasis was on increased production rate; there was small demand for product variations and the market was characterized by local competition. This was changed to cost reduction and emphasis on improved product quality in the CNC epoch (the 1970s and 1980s); manufacturing was dramatically affected by the invention of CNC machines as they provided more accurate control and means for increasing product variety. In the knowledge epoch (starting in the 1990s), the focus has shifted to responsiveness of a manufacturing system. This period is characterized by intensified global competition, high-pace of technological innovations and enormous progress in computer and information technology [1–3]. Rapid progress was made in areas such as management information systems, development of software/application programs for various purposes, advances in communication systems (hardware and software), and penetration of computer technology in various fields [4–7]. Global competition and information technology are therefore the driving forces behind recent changes in manufacturing. These conditions require a responsive manufacturing system that could be designed rapidly, able to convert quickly to the production of new product models, able to adjust capacity quickly, able to integrate process technology and to produce an increased variety of products in unpredictable quantities.

As reported by Lee [8] and Garro and Martin [9], underlying components and structure of a manufacturing system significantly affect its ability to be reconfigured for rapid and cost effective production of new products. In their studies it was shown that modular design of machine tools provided the manufacturing systems with the necessary tools for quick integration and restructuring as required for rapid response to the fluctuating market. On close examination of the manufacturing techniques introduced so far (e.g. FMSs, lean, JIT), one observes that they do not possess a modular structure in terms of software and hardware; therefore, they are not always flexible enough and can not accommodate rapid changes.

---

The same views are strongly supported by the results of recent surveys carried out in Japan and the USA to assess the accomplishments of some of the available manufacturing systems (e.g. flexible manufacturing systems) and user satisfactions with their performance [10–12]. The results indicate that some manufacturers have lost interest in FMSs, and FMS sales have been dropping [10]. Software complexity, lack of reconfigurability, investment cost, maintenance cost and rapid obsolescence are among the dominant factors in making FMSs not very attractive [8,10–12]. As a result, and due to demands of manufacturers, new approaches to the design of manufacturing systems are proposed which are substantially different from conventional methods. For example, the so called ‘holonic manufacturing systems (HMSs)’ have been introduced by the Japanese firms to address the needs of industry [10]. The underlying design philosophy of HMSs (bottom-up design) is totally different from FMSs (top-down design). In another study [8], the simultaneous design of products and manufacturing systems is proposed to enhance the overall reconfigurability of production.

The concept of the reconfigurable manufacturing system (RMS) was introduced to address new challenges in modern manufacturing systems. Such a system can be created rapidly using basic process modules – hardware and software – that can be re-integrated quickly and reliably. Reconfiguration allows adding, removing, or modifying specific process capabilities, controls, software, or machine structure (Figure 1) to adjust production capacity in response to changing market demands or technology. For a manufacturing system to be readily reconfigurable, the system must possess certain key characteristics. These include modularity (design all system components, both software and hardware, to be modular), integrability (design systems and components for both ready integration and future introduction of new technology), convertibility (allow quick changeover between existing products and quick system adaptability for future products), diagnosability (identify quickly the sources of quality and reliability problems that occur in large systems), and customization (design the system capability and flexibility (hardware and controls) to match the application (product family)). As shown in Figure 2, there are many aspects of reconfiguration. These include various configurations of the production system (e.g. serial, parallel, hybrid), reconfiguration of the factory communication software, configuration of new machine controllers, building blocks and configuration of modular machines, modular process and modular tooling.

To achieve the goals of reconfigurable manufacturing systems, there are several key enabling technologies that should be developed and implemented to realize the benefits of RMSs. The following sections are devoted to a review of these technologies and the ways they contribute to success of RMSs.

Figure 1 Comparison of the key hardware and software features of manufacturing systems

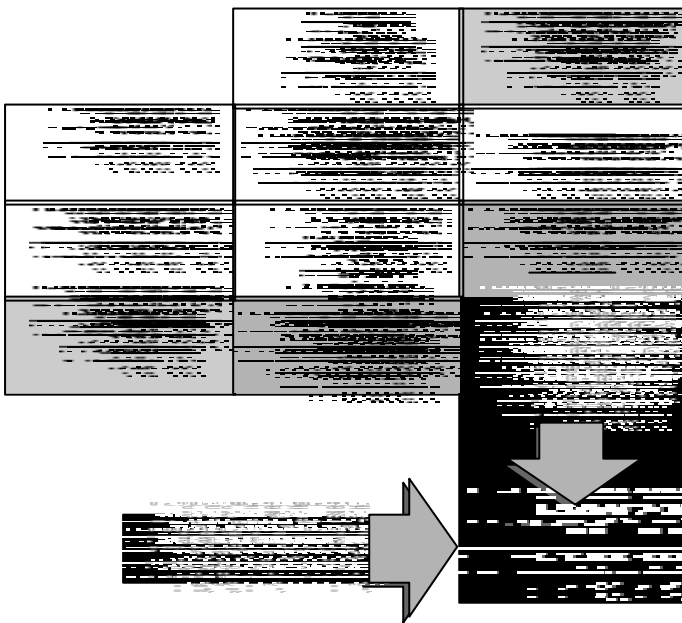
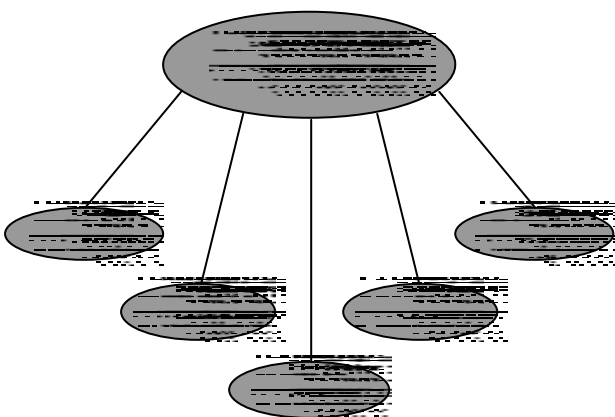

Figure 2 Aspects of reconfiguration (reconfigurable system, software, controller, machine and process) for RMSs



## **2 Technologies for reconfigurable machining systems**

At the system level, there can be several system configurations for production of the same part family. Development of the necessary tools and methodologies to design the system, and evaluation of various configurations (based on life-cycle economics, quality, system reliability and preferences of decision maker(s)) is needed. As far as system software/hardware architecture is concerned, it should have certain features to support the five key characteristics of RMS. It should have a modular structure and be 'open' such that upgrading and customization of the system is practical while integration of new software is possible. Control of RMSs is another important subject to be studied. By noting that the system configuration changes (based on market demand), the parameters of the production machines such as damping, mass, and inertia will change accordingly. Therefore, the controller should have the ability to reconfigure and adapt itself to these new conditions.

Development of a unified approach for design and construction of reconfigurable machine-tool systems is another important challenge in the design of RMS. Like any other design problem, a compromise should be made among certain variables of the system. The RMS design problem is, however, quite complex since the number of variables is large.

Reduction in lead time requires the adoption of CAD techniques for production systems, and that the system be readily diagnosed for reliability and product quality problems. Rapid restructuring of a system requires component design for reusability and quick integration. Ease of upgrading requires that the components be designed for substitution, and that the system be designed for integration of new technology and new functionality.

The following sub-sections provide a more detailed review of the technology requirements of RMSs. They include system design and configuration for RMSs, their software and communications requirements, control and monitoring, machine design aspects of RMSs, processes and tooling, and intelligent sensors and multi-sensor data fusion for system reliability and safety.

### *2.1 System designs and configuration aspects of RMSs*

There are a number of steps involved in manufacturing a part from its conceptualization to production, including product design, process planning, production system design, and process control. Computers are used extensively in all these stages to make the process easier and faster. As a result, there are many software tools available such as computer-aided design, process planning and computer-aided manufacturing. However in spite of all these developments, there is not a systematic approach to their integration and implementation, and each stage is done separately with little interaction with the rest of the system. Also, most of these developments assume a unique and predefined configuration for the machines [13]. RMSs offer a dynamic configuration and each one has its own advantages/disadvantages in terms of cost, quality and reliability of the system. For example, a system with serial configuration of the machines (Figure 3) has minimum cost but is less reliable; however, when the same machines are arranged in parallel the system becomes more reliable but it becomes more expensive too. Therefore it is possible to compromise between these two extreme cases and design a hybrid system (Figure 3) which is optimized in terms of cost, quality and reliability. Literature surveys suggest that there is a need for either development of new theories and approaches or adoption of some existing concepts to the systematic design and optimization of production systems. At the system level, design and selection of an optimal machining system configuration for a particular product family requires new methodologies, as the research

to date on optimal machining system design is quite limited. Evaluation of machining configurations should be based on preferences of decision-makers and take into account factors such as quality, cost, timing and part variation. A literature survey suggests that in-depth studies are needed of some of the issues related to system integration for RMS – e.g. integration rules, economic evaluation of alternative configurations, cost models, analysis and selection of machining systems, and the design of configurations to achieve minimum idle time and optimal system productivity [14,15]. Some existing techniques, such as life-cycle economic modelling and imprecisely specified multi-attribute utility theory [16,17] can be adapted to this class of problems. As an RMS can have many configurations, it is important to observe clearly the effects of changes in the system configuration on factors such as part quality, and system productivity, reliability, and cost of the system [18,19]. A survey of the literature suggests that there is a need for the development of new underlying theories, or the extension of existing theories and concepts, to resolve these issues in the context of RMS. For example, to produce high-quality products, it is necessary to locate sources of product quality variation. A method previously used for automotive body assembly – the stream-of-variation theory – can be extended to trace back quality problems in machining to their manufacturing sources [20].

**Figure 3** Three possible configurations with four machines

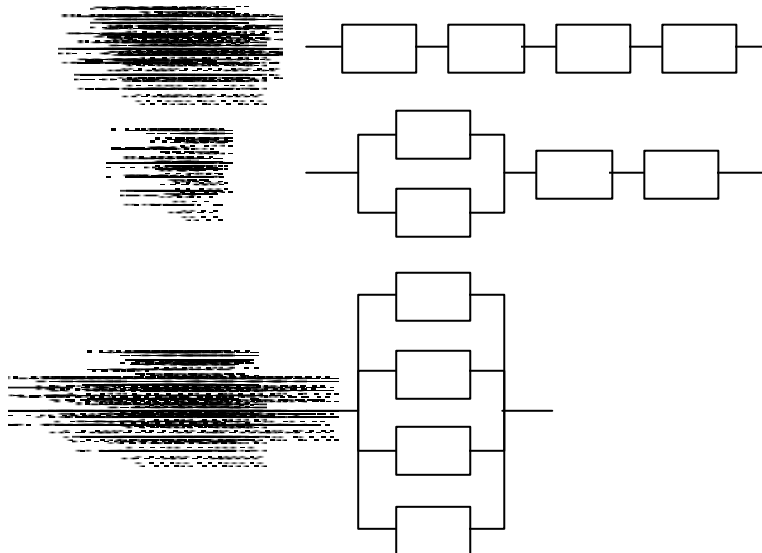

## 2.2 Software/hardware architecture aspects of RMSs

An integral part of RMSs is the software required to handle tasks at various levels such as control, monitoring and communications among mechanical, electrical and electronic components (at low level) as well as higher levels tasks

such as process planning, user interface, process control and data collection/report from the process. Therefore, the structure and functionality of the communication and control software is very critical and directly affects the performance of the entire system. From the economic point of view, approximately 25% of the total initial cost of a machine tool is attributed to the software development. The modular nature of RMSs requires that the software/hardware of the system be in a modular form; i.e. consists of separate entities totally decoupled from the rest of the system such that addition/modification of a component is possible. Furthermore, it should be extensible (i.e. be able to respond to new features, environments, and requirements), modifiable/reusable (easy to modify and usable in different programs, if necessary), and most importantly reconfigurable (able to accommodate different configurations and to support internal/external interactions of modules without modifications in the software). As reported [21], object-oriented programming is a reasonable choice as it has already been used in other areas for real-time control applications [22]. Equally important is the hardware architecture that should be compatible and responsive to the properties of the software (mentioned above), interacting in harmony to support the essential features of RMSs.

A literature survey reveals that CNC machines have been equipped with proprietary control systems; i.e. the users do not have access to the controller and further modifications/enhancements of the system (by the users) are either impossible or very costly. This has significantly hindered the applications of efficient control algorithms and the addition of new sensors for process improvement/monitoring purposes, and has suppressed the automation of the entire production system [21,23]. This type of controller is unable to support the basic characteristics of RMSs such as convertibility and integrability. To achieve them, the system should be open [21,23–26] to allow continuous upgrading and possess an ‘open architecture’ (Figure 4) to accommodate the above features [27–30]. It should be mentioned that a unified definition for ‘open-architecture systems’ does not exist. What is meant by ‘openness’ and what are the domains of the ‘systems’ depend on how they are viewed. Probably, the clauses ‘open-architecture/open systems’ have been the most overused and misinterpreted phrases in the history of control/automation systems (software/hardware). In this regard, some similarities can be observed between the application and interpretation of the phrases ‘open-architecture systems’ and ‘computer-integrated manufacturing (CIM)’ [31] which was at a similar stage of development in the 80s. In spite of all the ongoing debates [23,32], it seems reasonable to state that an open-architecture control system should possess the common capabilities and functionality offered by standard platforms such as standard computing architecture (ISA/VME Bus), standard processors (Intel 1x86/Motorola 680x0/PowerPC), standard operating system (Windows NT/Unix), and standard languages (C/C++, Visual C++/Basic, etc.).

A survey of the open architecture machine-tool control literature reveals that there are a number of projects underway with different objectives such as enhanced machine controller (EMC) at Sandia National Laboratories, industry-government collaborative programmes such as big three open modular control (OMAC), Oasys, and Icon [32]. The National Institute of Standards and Technology (NIST) has proposed and implemented a reference model architecture for real-time control systems (RCS Reference Model) [23,33]. Based on that model, and to address industrial requirements, the next generation controller (NGC) programme – sponsored by the US Air Force, and executed by Martin Marietta – prepared the specifications for open system architecture standard [34]. The University of Michigan (UM) has contributed to the development of next-generation machine controllers by effectively creating an open and readily modifiable control system for CNC machines. Issues such as distributed networks, design of hierarchical controllers, and their software structures have been investigated [35–42]. The largest-scale project in the

field of control software (in Europe) is the open system architecture for controls within automation (OSACA) [21]. Also noteworthy are projects on the design of reconfigurable real-time software at Carnegie Mellon University [43], OSEC (in Japan), and at the University of British Columbia – where a hierarchical multiprocessor and motion control system has been designed [43,45].



Figure 4 Open-architecture principle in machine tool control systems

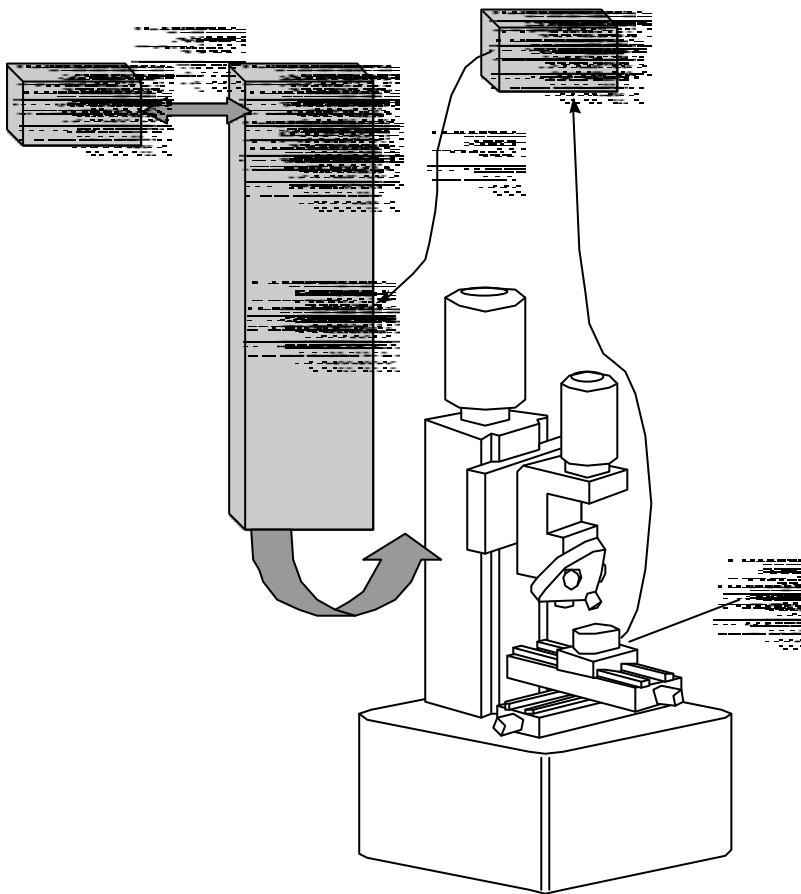

### 2.3 Measurement and control aspects of RMSs

The measurement and control systems for an RMS should be able to support its key characteristics. Currently, commercially available controllers allow only limited access by users; in fact, a majority of industrial controllers (e.g. axis motion controllers) have a fixed control structure (e.g. traditional PID). This is the bottle neck for the existing controllers which makes them unsuitable for RMSs. More studies are therefore needed for the design of proper PC-based control systems and their architecture (software/hardware) [24]. As pointed out by Proctor and Albus [23], PC-based control systems for machine tools will revolutionize the manufacturing systems in the same way that the PC did

for office automation. There are reports of recent efforts in the industrial sector to realize the importance of this problem and try to find proper solutions [46,47]. Some of the companies who are actively involved in development of PC-based controllers are Allen-Bradley, Cincinnati Milacron, Cranfield Technologies, HP Trellis, Wizdom Controls, and Icon.

On the other hand, while the control algorithms used in CNC machines are primitive, there have been reports during the last two decades of research achievements on the application of advanced control policies to machining processes [48–51], on-line tool wear measurement and estimation [52,53], multi-sensor systems employed to report on a number of process variables, such as temperature, forces, and tool wear, [54–58], and the selection of proper control strategies [59]. But most of them are not utilized in the current industrial controllers and in particular in CNC machines because of the reasons stated above.

The same view is valid for programmable logic controllers (PLC). To date, programmable logic controllers (PLC) have been used in industrial automation to control and monitor discrete event systems. However, the needs of industrial automation and manufacturing systems have changed dramatically due to recent developments in information management systems. The new requirements are mostly dictated by the capabilities of manufacturing machines and components in terms of communicating with the rest of the system, their upgrading and easy modifications, versatility and programming languages. The fact that PLCs were originally designed to replace the hard-wired relay logic [60] used in the control of machinery, suggests that they have limited capabilities in this regard and in general they suffer from the following:

- limited capabilities for on-line operations (the entire system should be stopped to download a new logic program);
- slow communications between PC and PLC (mostly done through the serial port);
- no standardization of the software for communications at high/low level and often very expensive;
- not open to the users (i.e. every vendor has his own components which do not fit the others);
- overall costs of the system are very high (the costs for user interface and their software, components are very expensive as compared to PC-based systems); and
- limitations on the programming language used.

These are the bottlenecks with available PLCs which make them rather unsuitable for RMSs. The functionality of PLCs can be enhanced, however, by proper implementation of available I/O boards (and compatible software) on a much more compact and industrial PC platform such as PC/104 (its form factor is very small while it has the same functionality as a PC in terms of communications and other functions) at fairly low costs. Many industrial control companies are delivering PC-based systems (hardware/software) for implementing PLC functions [32]; also, progress is being made in integrating the functional logic (discrete) of PLCs and machine-tools motion control (continuous) by utilizing modelling capabilities of Petri nets (Figure 5) [61–63]. Another critical issue in the design of RMSs and other modern intelligent manufacturing systems is communication. So far, networking and data communication between CNC controller/PLC or PLC/PLC have been done through proprietary networks (similar to the situation with controllers); i.e. related communication systems, protocols, and software/hardware are not open to the users/other vendors. Therefore, further system enhancements are severely restricted (in some cases, means of serial communication are provided; but

the speed of communication is not fast which makes them unfit for real-time applications). Cost is another important issue. Consider a set of sensors/devices communicating with a central computer/controller. Traditionally, they should be hard-wired to the central controller/PLC; so the costs associated with wiring, connections, control cabinet, space, labour, maintenance and trouble shooting are quite high. With a proper communication system, the same sensor/device is connected to a network (locally) which takes care of all data reporting and condition monitoring of the entire manufacturing system. A literature survey suggests that there are reports of recent developments of built-in intelligent control devices and communication networks such as Devicenet [23,64]. Progress has also been made in development of standard terminology for message and instruction sets such as manufacturing message specification (MMS), which are necessary for shop floor communication [65]. In the Devicenet network, local devices have built-in intelligence (with little cost) and their communication capabilities are enhanced. Therefore, control decisions/actions are made locally and the entire control system for manufacturing is decentralized.

**Figure 5** Examples of modelling capabilities of Petri nets

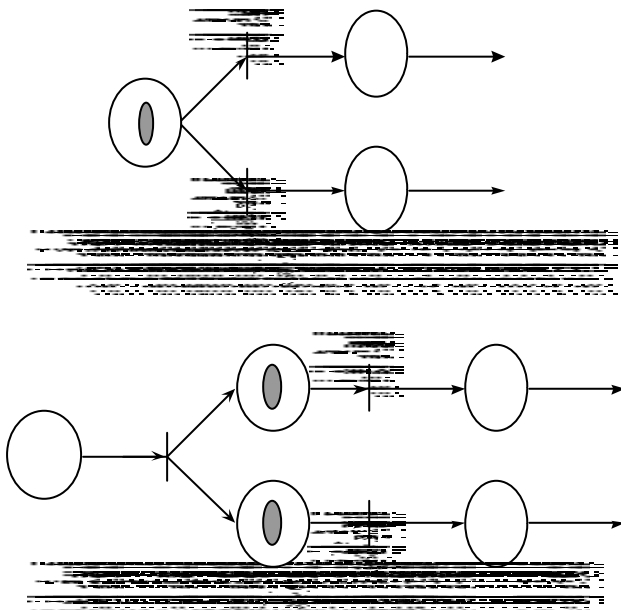

#### 2.4 Machine design aspects of RMSs

Modular form and dynamic structure (in terms of configuration) of RMSs makes the design of their components a highly complex issue. In conventional design of machines and in particular machine tools, their elements were optimized based on a unique and predefined architecture. The major task, therefore, was to optimize a machine for a specific

configuration (i.e. at machine level). However, an RMS can be created (according to requirements) from some basic modules the so called ‘building blocks’ [66] (Figure 6). Therefore, since there is more than one configuration of the machine, optimization should be made for several possible configurations, which is much more involved than a single configuration. There are reports of modular fixture design and programmable clamps to hold a component firmly [67]. For example, in the latter, based on the characteristics of commonly used fixtures, an approach is introduced for design of modular fixtures. However, it should be noticed that clamps and fixtures are considered to be auxiliary equipment of machine tools and the dynamics involved is not a major factor in their design.

Another challenge in mechanical design of RMSs is the specification of the extent of modularity that is required for a process. In other words, what are the building blocks of a reconfigurable machining system which produces the most efficient and optimized system? In a report by Rogers and Bottaci [68], the principle modules (mechanical) are considered to be processing subsystems (i.e. process machine primitives), actuator elements (used to move the axis of a machine or build simple material and component transfer system), and tooling and fixtures (to support a specific configuration). But, a specific approach is not provided as how to design the system.

To support the characteristics of RMSs, there is a need to develop a new theory – which we call reconfiguration design theory – for topological synthesis of reconfigurable machines, optimization of machine chains-of-motion and structure, and analysis of the associated problems (such as wear, vibration, and stiffness). Such a theory should be capable of analysing and estimating the machine accuracy and repeatability once different modules of the machine (e.g. machine structure, tool-support, spindle and working-holding table) are identified. In this regard, there are reports of achievements on the synthesis of machining systems [69] which can be extended to the design of generic building blocks, conceptual design, and their simulation.

## 2.5 *Process and tooling aspects of RMSs*

After the RMS is reconfigured, the production system must typically be ‘fine-tuned’ before it can consistently produce at the required quality and production volume. This is referred to as ramp-up, and it takes a long time (months or even years) with traditional production systems. For the RMS to be practical, ramp-up time should be significantly reduced for both new and reconfigured systems. This objective requires diagnostics, calibration, and ramp-up methodologies (Figure 7).

One of the key factors in evaluating the product quality is precision in machining. To achieve that, the cutting operation is tightly controlled by using real-time data collected from sensors located at different locations of work-piece, tool, and machine tool [70–74]. Also, some measurements are made for process monitoring purposes with the objective of preventing irreparable damage to the work-piece and the machine [75]. In general, real-time measurements of the following variables are required: dimensional errors, quality of surface finish, thermal deformations during machining, and dynamic deformations of the workpiece; chatter vibration, cutting force, condition of the chip, and identification of the cutting for process monitoring [76]; thermal deformation, dynamic deformation of the machine elements, and structural vibration of the machine tool [77] and wear, failure, and thermal deformations of the tool [70,75].

**Figure 6** Examples of building blocks of reconfigurable machining systems

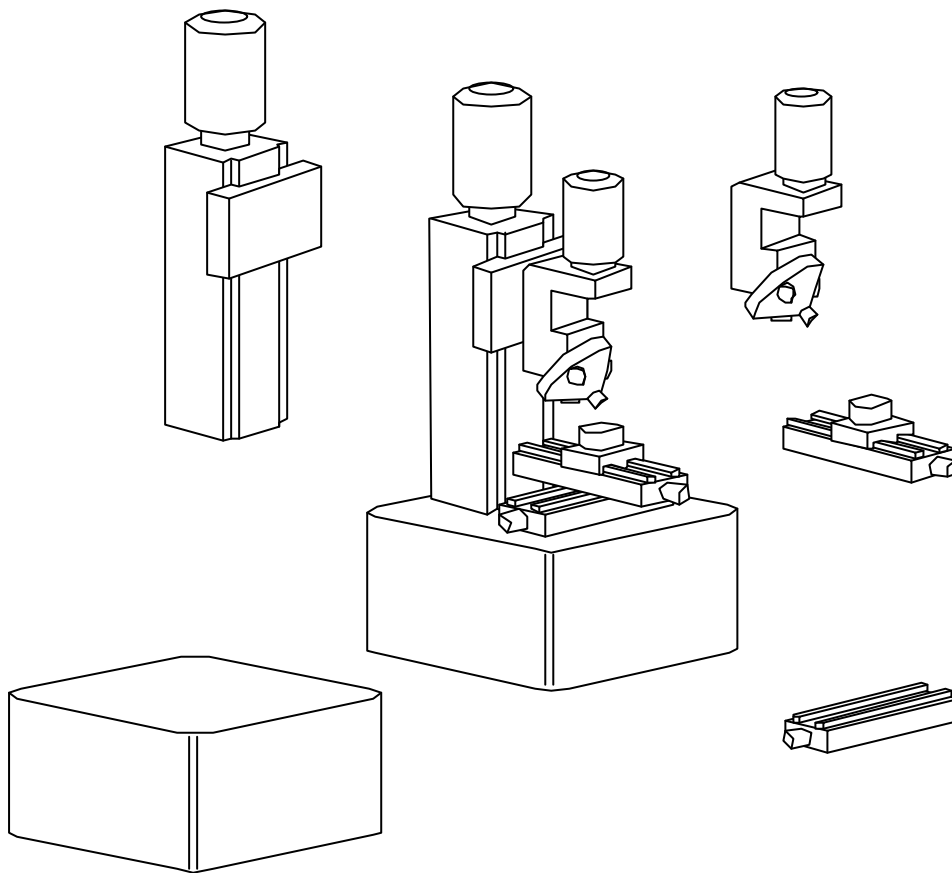

Regardless of the type of process, there are several key components in modern intelligent sensor-based machine monitoring systems including a data-acquisition system which consists of sensors and signal conditioning systems for collecting (remote/local; software/hardware; on/off line) data (for monitoring and reliability estimation), signal processing techniques to extract valid data (software), and decision making (software) routine to analyse the data and classify the results (software). In essence, the entire process of control and monitoring is very similar to the actions of humans and ideally, should duplicate the response of an experienced and efficient machine operator. Further details of general description and classifications of the sensors (contact/non-contact), techniques of measurements (direct/indirect) and sensor-data fusion (to improve the accuracy and reliability) and their features and limitations are provided by Mehrabi and Ulsoy [78].

Figure 7 Ramp-up methodology for reconfigurable manufacturing systems

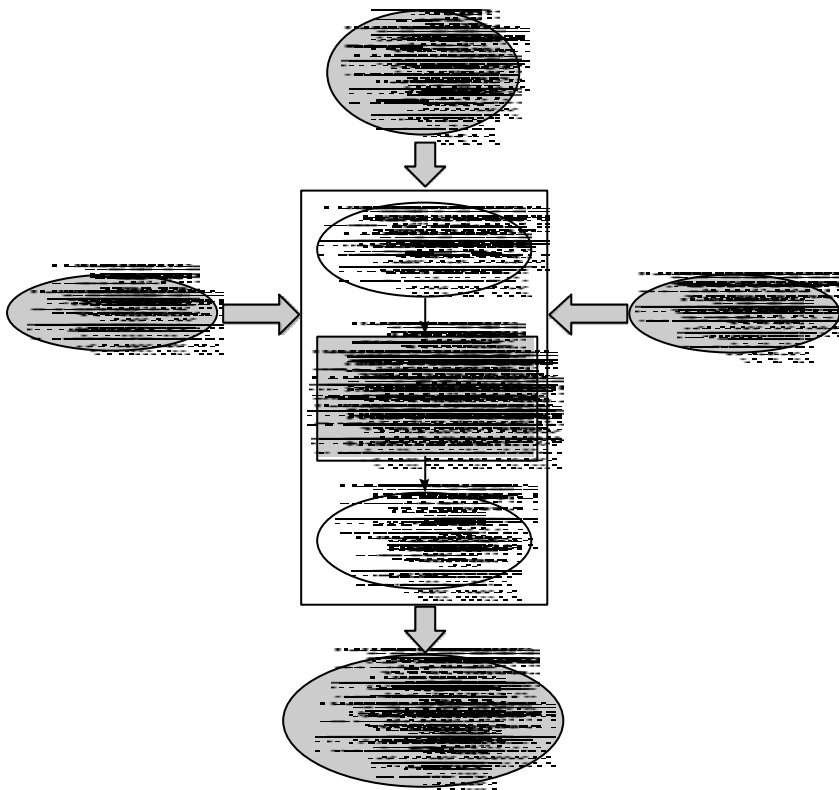

### 3 Future trends/research directions

It is very difficult to forecast long term trends for manufacturing systems, since the changes are happening at a very fast pace. However, it is possible to extrapolate future trends from the current situation by analysing and specifying the key drivers behind the changes. Certainly, availability and distribution of information plays an important role in this transition and it is considered as one of the key drivers. In this regard, there is a need for improvement and standardization of various components (such as data interfaces, protocols and communication systems) so that data can be transferred to the desired location at a faster rate.

There have been reports of several studies relevant to future manufacturing technologies, processes, and machine tools [79–81]. They have all agreed that manufacturing should be viewed, designed and optimized as a system (as a whole) to achieve the required responsiveness (i.e. shorter lead-time and ramp-up time). In this regard, there is a need for fundamental understanding of manufacturing processes, equipment, and technologies and their relations to the rapidly changing market.

There are many research efforts underway, however we are still at the beginning of a new era of modern manufacturing systems and there are many barriers to their advancement [79]. As reported, there is a lack of available tools and methodologies to analyse the trade-off among processes, equipment, life-cycle costs, and initial investment. Also, there is a lack of effective communication among product designers, process designers and machine-tool designers, as needed for the design of an optimized manufacturing system.

Advances in manufacturing will not occur without the proper machine tools and equipment. Machine tools are undergoing some fundamental changes in terms of their structure (modular structure) and components (controllers, hardware/software, spindles, tooling, sensors, etc.); therefore new theories, design concepts and methodologies should be developed for these purposes (Figure 8) [9,68,80,81]. These changes are fundamental to the success of future reconfigurable manufacturing systems (RMSs).

## References

- 1 Mehrabi, M.G. and Ulsoy, A.G. (1997) 'State-of-the-art in reconfigurable manufacturing systems', *ERC/RMS Report # 2*, Vol. I, Engineering Research Center for Reconfigurable Machining Systems (ERC/RMS), The University of Michigan, Ann Arbor.
- 2 Mehrabi, M.G., Ulsoy, A.G. and Koren, Y. (1998) 'Reconfigurable manufacturing systems: key to future manufacturing', *Proceedings of the 1998 Japan-USA Symposium on Flexible Automation*, pp.677-682, Otsu, Japan.
- 3 Jaikumar, R. (1993) '200 Years to CIM', *IEEE Spectrum*, Vol.30, pp.26-27.
- 4 Gyorki, J. R. (1989) 'How to succeed CIM', *Machine Design*, Vol. 61, pp.99-105.
- 5 Sheridan, J. H. (1989) 'Towards the CIM solution', *Industry Week*, Vol. 238, pp.35-80.
- 6 Beckert, B. (1990) 'Integrated manufacturing: new wizards of management', *Industry Week*, Vol. 239, pp.60-84.
- 7 Teresko, J. (1990) 'EDM: the next step toward CIM', *Industry Week*, Vol. 239, pp.55-57.
- 8 Lee, G.H. (1997) 'Reconfigurability consideration design of components and manufacturing systems', *Int. Journal of Advanced Manufacturing Technology*, Vol. 13, No. 5, pp.376-386.
- 9 Garro, O. and Martin, P. (1993) 'Towards new architecture of machine tools', *Int. J. Prod. Res.*, Vol.31, No.10, pp.2403-2414.
- 10 Lee, J. (1997) 'Overview and perspectives on Japanese manufacturing strategies and production practices in machinery industry', *ASME Journal of Manufacturing Science and Engineering*, Vol. 119, pp.726-731.
- 11 Ulsoy, A.G. and Heytler, P. (1997) *A Survey of Flexible and Reconfigurable Manufacturing Systems (RMSs)*, Internal Report, Engineering Research Center for Reconfigurable Machining Systems (ERC/RMS), The University of Michigan, Ann Arbor.
- 12 Mehrabi, M.G., Ulsoy, A.G., Koren, Y. and Heytler, P. (1998) 'Future trends in manufacturing: a survey of flexible and reconfigurable manufacturing systems', *Journal of Manufacturing Systems* (in press).

- 13 Cho, E., (1994) 'A formal approach to integrating computer-aided process planning and shop floor control', *ASME Journal of Engineering for Industry*, Vol. 110, pp.108-116.
- 14 Klutke, G.A. and Lawrence, M.S. (1991) 'Transient behavior of finite capacity tandem queues with blocking', *Int. Journal of Systems Science*, Vol. 22, No. 11, pp.2205-2215.
- 15 Klutke, G.A. and Wortman, A.W. (1996) 'The backlog process in queues with random service speed', *Int. Journal of Systems Science*, Vol. 27, No. 7, pp.641-645.
- 16 White, C.C. and Sykes, E.A. (1986) 'A user preference guided approach to conflict resolution in rule-based systems', *IEEE Transactions on Systems, Man and Cyber.*, Vol. SMC-16, No. 2, pp.276-278.



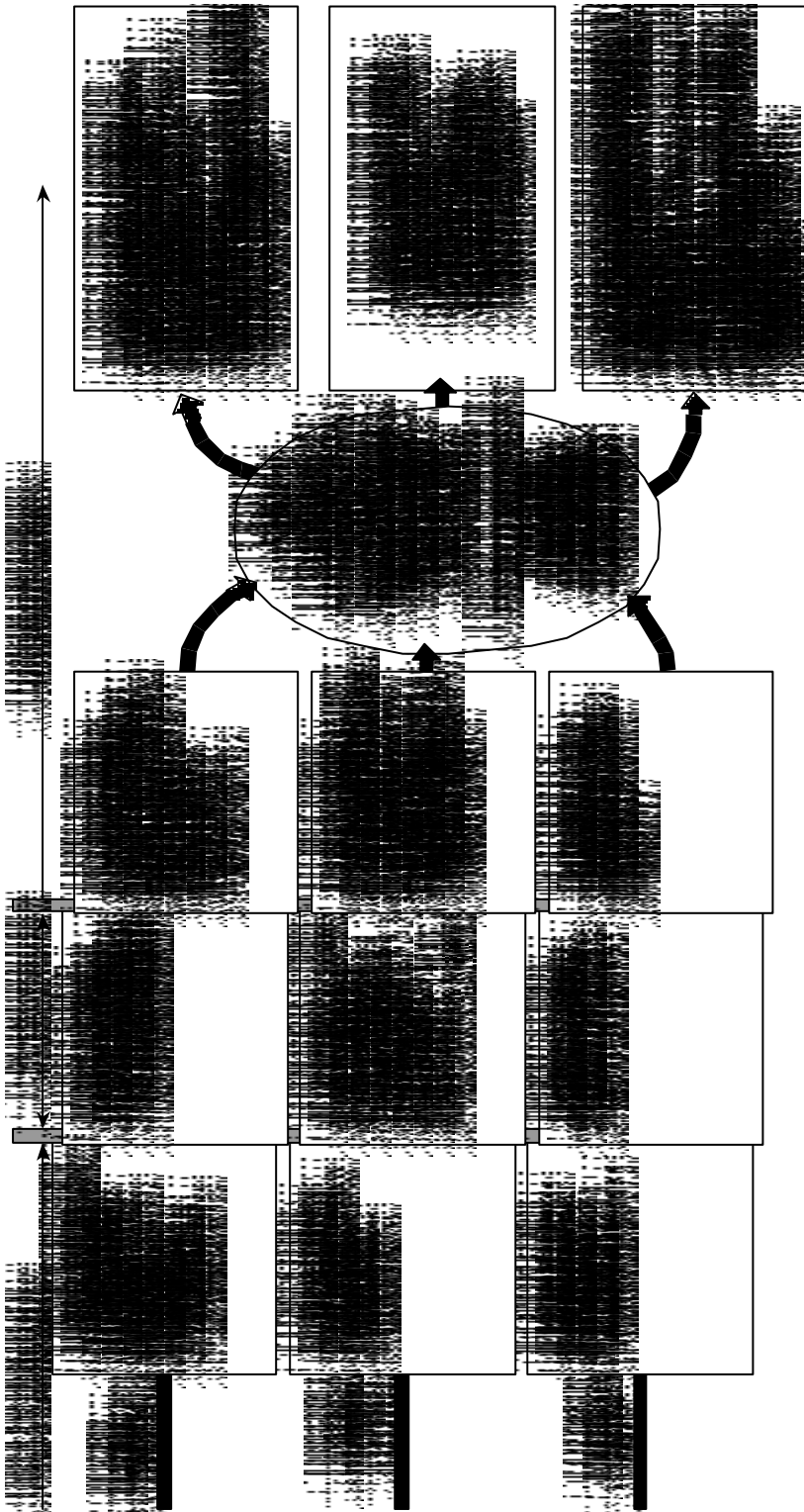

Figure 8 The key role of reconfigurable manufacturing systems (RMS) in future manufacturing

- 17 White, C.C. and Anendaligam, G. (1993) 'A penalty function approach to alternate pairwise comparisons in ISMAUT', *IEEE Transactions on Systems, Man, and Cyber.*, Vol. 23, No. 1, pp.330-333.
- 18 Sood, S., Wright, P.K. and MacFarlane, J. (1993) 'Process planning: a review', *Intelligent Concurrent Design: Fundamentals, Methodology, Modeling and Practice, The ASME Winter Annual Meeting*, DE-Vol. 66, New Orleans, LA.
- 19 Hassan, M. M. D. (1994) 'Machine layout problem in modern manufacturing facilities', *International Journal of Production Research*, Vol. 32, pp.2559-2584.
- 20 Hu, S. J. (1997) 'Stream of variation theory for automotive body assembly', *Annals of the CIRP*, Vol. 46, No.1.
- 21 Pritschow, G. and Muller, J. (1997) 'Object-oriented modeling of numerical control modules', *Production Engineering*, Vol. 4, pp.83-86.
- 22 Awad, M., Kusela, J. and Ziegler, J. (1996) *Object-Oriented Technology for Real-Time Systems*, Prentice Hall, NJ.
- 23 Proctor, F. M. and Albus, J. S. (1997) 'Open-architecture controllers', *IEEE Spectrum*, Vol. 34, pp.60-64.
- 24 Birla, S.K. and Shin, K.G. (1995) 'Software engineering of control systems for agile machining: an approach to life-cycle economics', *Proceedings of the IEEE Intl. Conference on Robotics and Automation*, Nagoya, Japan.
- 25 Wright, P.K. and Greenfeld, I. (1990) 'Open architecture manufacturing: the impact of open-system computers on self-sustaining machinery and the machine tool industry', *Proceedings of the Manuf. Int. 90, Part 2: Advances in Manufacturing*, pp.41-47.
- 26 Wright, P.K., Pavlakos, E. and Hansen, F. (1991) 'Controlling the physics of machining on a new open-architecture manufacturing system', *Design, Analysis, and Control of Manufact. Cells, The ASME Winter Ann. Meeting*, Atlanta, Georgia, pp.129-144.
- 27 Duffie, N.A. and Bollinger, G. (1980) 'Distributed computing systems for multiple-processor industrial control', *Annals of CIRP*, Vol. 29, No.1, pp.357-362.
- 28 Dilts, D.M., Boyd, N.P. and Whorms, H.H. (1991) 'The evolution of control architecture for automated manufacturing systems', *Journal of Manufacturing Systems*, Vol. 10, No.1, pp.79-93.
- 29 Duffie, N.A. and Prabhu, V.V. (1994) 'Real-time distributed scheduling of heterarchical manufacturing systems', *Journal of Manufacturing Systems*, Vol. 13, No.2, pp.94-107.
- 30 Ardekani, R., and Yellowley, I. (1996) 'The control of multiple constraints within an open architecture machine tool controller', *ASME Journal of Manufacturing Science and Engineering*, Vol. 118, No.3, pp.388-393.
- 31 Bedworth, D.D., Handerson, M.R. and Wolfe, P. (1991) *Computer Integrated Design and Manufacturing*, McGraw-Hill, New York.
- 32 Owen, J.O. (1995) 'Opening up controls architecture', *Manufacturing Engineering*, Vol. 115, pp.53-60.
- 33 Proctor, F.M. and Micholski, J. (1993) 'Enhanced machine controller architecture overview', *NISTIR -5331, NIST Tech. Report*, Gaithersburg, MD 20899.
- 34 Wright Laboratory (1994) *Next Generation Controller Specification for an Open Systems Architecture Standard*, Manufacturing Technology Directorate.
- 35 Koren, Y., Jovane, F. and Pritschow G. (eds.) (1998) *Open Architecture Control Systems*, ITIA Series, Italy.
- 36 Koren, Y. and Lo, C.C. (1992) 'Variable-gain cross-coupling controller for contouring', *CIRP Annals*, Vol. 40, No. 1, pp.371-374.
- 37 Pasek, Z.J., Park, J., Shan, Y., Koren, Y., Shin, K. and Ulsoy, A.G. (1995) 'An open architecture real-time control for machining processes', *Proceedings of the 27th CIRP Int. Seminar on Manufacturing Systems*, Ann Arbor, MI.

- 38 Ulsoy, A.G. and Koren, Y. (1993) 'Control of machining processes', *ASME Journal of Dynamic Systems, Measurement and Control*, Special 50th Anniversary Issue, Vol. 115, No. 2(B), pp.301-308.
- 39 Koren, Y., Pasek, Z., Ulsoy, A.G. and Benchetrit, U. (1996) 'Real-time open control architectures and system performance', *CIRP Annals*, Vol. 45, No. 1, pp.377-380.
- 40 Park, J., Pasek, Z.J., Shan, Y., Koren, Y., Shin, K.G. and Ulsoy, A.G. (1996) 'An open-architecture real-time controller for machining processes', *Manufacturing Systems*, Vol. 25, No. 1, pp.23-27.
- 41 Zhou, L., Washburn, M.J., Shin, K.G. and Rundensteiner, E.A. (1996) 'Performance evaluation of modular real-time controllers', *The ASME Int. Mech. Eng. Cong. and Exposition; DSC Vol. 58*, pp.299-306.
- 42 Shin, K. and Kim, H. (1992) 'Derivation and application of hard deadlines for real-time control systems', *IEEE Transactions on Systems, Man, and Cybernetics*, Vol. 22, pp.1403-1413.
- 43 Stewart, D.B. (1993) 'Design of dynamically reconfigurable real-time software using port-based objects', *CMU-RI-TR-93-11, CMU Technical Report*, Pittsburgh, PA.
- 44 Altintas, Y. and Munasinghe, W.K. (1994) 'A hierarchical open-architecture CNC system for machine tools', *Annals of the CIRP*, Vol. 43, No. 1, pp.349-354.
- 45 Altintas, Y. and Munasinghe, W.K. (1996) 'Modular CNC design for intelligent machining. Part 1: Design of a hierarchical motion control module for CNC system machine tools', *ASME Journal of Manufacturing Science and Engineering*, Vol. 118, No.3, pp.514-521.
- 46 Baab, M. (1996) 'Device, sensor networks rock the foundation of machine control', *Control Engineering*, Vol.43, pp.65-68.
- 47 Hollenback, D. (1996) 'PCs provide the foundation for open architecture', *Control Engineering*, Vol. 43, pp.75-78.
- 48 Ulsoy, A.G., Koren, Y. and Rasmussen, F. (1983) 'Principal developments in the adaptive control of machine tools', *ASME Journal of Dynamic Systems, Measurement, and Control*, Vol. 105, No. 2, pp.107-112
- 49 Daneshmend, L.K. and Pak, H.A. (1986) 'Model reference adaptive control of feeddrive force in turning', *ASME Journal of Dynamic Systems, Measurement, and Control*, Vol. 108, pp.215-222.
- 50 Watanabe, T. (1986) 'A model-based approach to adaptive control optimization in milling', *ASME Journal of Dynamic Systems, Measurement and Control*, Vol. 105, pp.56-64.
- 51 Ulsoy, A.G. and Koren, Y. (1989) 'Applications of adaptive control theory to machine tool process control', *IEEE Control Systems Magazine*, Vol. 9, No. 4, pp.33-37.
- 52 Danai, K. and Ulsoy, A.G. (1987) 'A dynamic state model for on-line tool wear estimation in turning', *ASME Journal of Engineering for Industry*, Vol. 109, No. 4, pp.396-399.
- 53 Wright, P.K. and Bourne, D.A. (1988) *Manufacturing Intelligence*, Addison-Wesley, MA.
- 54 Lan, M.S. and Dornfeld, D.A. (1984) 'In-process tool fracture detection', *ASME Journal of Engineering Materials and Technology*, Vol. 106, pp.111-118.
- 55 Stein, J.L. and Shin, K.C. (1986) 'Current monitoring of field controlled dc spindle drives', *ASME Journal of Dynamic Systems, Measurements and Control*, Vol. 108, pp.289-295.
- 56 Lee, J. ( 1987) 'Apply force/torque sensors to robotics applications', *Robotics*, Vol. 3, No. 2, pp.189-194.
- 57 Rangwala, S. and Dornfeld, D.A. (1990) 'Sensor integration using neural networks for intelligent tool condition monitoring', *ASME Journal of Engineering for Industry*, Vol.112, pp.219-228.

- 58 Chow, J.G. and Wright, P.K. (1994) 'On-line estimation of tool/chip interface temperatures for a turning operation', *ASME Journal of Engineering for Industry*, Vol. 110, pp.56-64.
- 59 Furness, R., Ulsoy, A.G. and Wu, C.L. (1996) 'Supervisory drilling control', *ASME Journal of Engineering for Industry*, Vol. 118, No. 1, pp.10-19.
- 60 Batten, G.L. (1994) *Programmable Controllers*, McGraw-Hill, New York, NY.
- 61 Park, I., Tilbury, D. and Khargonekar, P.P. (1998) 'A formal implementation of logic controllers for machining systems using Petri nets and sequential function charts', presented at the *1998 Japan-US Symposium on Flexible Automation*, Japan.
- 62 Jackman, J., Linn, R.J. and Hyde, D. (1995) 'Petri-net modeling of relay ladder logic', *Journal of Design and Manufacturing*, Vol.5, pp.143-151.
- 63 Linn, R.J., Muralidhara, B. and M.E. Wang (1995) 'Petri-net based functional modeling of sequential control for integrated mechatronic machine tool design', *Journal of Design and Manufacturing*, Vol. 5, pp.187-202.
- 64 Paula, G. (1997) 'Building a better fieldbus', *Mechanical Engineering*, Vol. 119, pp.90-92.
- 65 Hollingum, J. (1987) *Implementing an Information Strategy in Manufacturing*, IFS Publication, UK.
- 66 Moon, Y. and Kota, S. (1998) 'Generalized kinematic modeling method for reconfigurable machine tools', *ASME DETC 98*, paper number MECH-5946, Sept., Atlanta, GA.
- 67 Cutkosky, M.R., Kurokawa, E. and Wright, P.K. (1982) 'Programmable conformable clamps', *AUTOFACT 4, Conference Proceedings*, pp.1151-1158.
- 68 Rogers, G. G. and Bottaci, L. (1997) 'Modular production systems: a new manufacturing paradigm', *Journal of Intelligent Manufacturing*, Vol. 8, pp.147-156.
- 69 Kota, S. and Chiou, S.J. (1994) 'Conceptual design of mechanisms based on computational synthesis of kinematic building blocks', *Journal of Research in Engineering Design*, Vol.4, pp.75-87.
- 70 Rao, S.B. (1986) 'Tool wear monitoring through the dynamics of stable turning', *ASME Journal of Engineering for Industry*, Vol. 108, No.3, pp.183-190.
- 71 Kannatey-Asibu, E. Jr. (1987) 'Analysis of the GMAW process for microprocessor control of arc length', *ASME Journal of Engineering for Industry*, Vol. 109, pp.172-176.
- 72 Rivin, E. and Kang, H. (1992) 'Enhancement of dynamic stability of cantilever tooling structures', *Int. Journal of Machine Tools and Manufacture*, Vol. 32, No. 4, pp.539-561.
- 73 Rivin, E. 1994, 'Vibration isolation of precision equipment', *Precision Engineering*, Vol. 17, pp.41-56.
- 74 Ni, J. and Wu, S.M. (1993) 'An on-line measurement technique for machine volumetric error compensation', *ASME Journal of Engineering for Industry*, Vol. 115, pp.1-7.
- 75 Li, S. and Albestawi, M.A. (1996) 'Tool condition monitoring in machining by fuzzy neural networks', *ASME Journal of Dynamic Systems, Measurement, and Control*, Vol. 118, pp.665-672.
- 76 Chryssolouris, G. and Domroese, M. (1989) 'An experimental study of strategies for integrating sensor information in machining', *Annals of CIRP*, Vol. 8, No.1, pp.425-428.
- 77 Ferreira, P.M. and Liu, C.R. (1986) 'An analytical quadratic model for the geometric error of a machine tool', *Journal of Manufacturing Systems*, Vol. 5, No. 1, pp.51-63.

- 78 Mehrabi, M.G. and Ulsoy A.G. (eds.) (1997) 'State-of-the-art in technologies related to reconfigurable manufacturing systems', *ERC/RMS Report # 2*, Vol. II, Engineering Research Center for Reconfigurable Machining Systems (ERC/RMS), The University of Michigan, Ann Arbor.
- 79 Agility Forum (1997) *Next-Generation Manufacturing: A Framework for Action*, Bethlehem, PA.
- 80 Aronson, R.B. (1997) 'Operation plug-and-play is on the way', *Manufacturing Engineering*, Vol. 118, pp.108-112.
- 81 Ashley, S. (1997) 'Manufacturing firms face the future', *Mechanical Engineering*, Vol. 119, pp.70-74.