



AALBORG UNIVERSITY
DENMARK

Aalborg Universitet

Reliability Analysis of Fatigue Failure of Cast Components for Wind Turbines

Rafsanjani, Hesam Mirzaei; Sørensen, John Dalsgaard

Published in:
Energies

DOI (link to publication from Publisher):
[10.3390/en8042908](https://doi.org/10.3390/en8042908)

Publication date:
2015

Document Version
Publisher's PDF, also known as Version of record

[Link to publication from Aalborg University](#)

Citation for published version (APA):
Rafsanjani, H. M., & Sørensen, J. D. (2015). Reliability Analysis of Fatigue Failure of Cast Components for Wind Turbines. *Energies*, 8(4), 2908-2923. <https://doi.org/10.3390/en8042908>

General rights

Copyright and moral rights for the publications made accessible in the public portal are retained by the authors and/or other copyright owners and it is a condition of accessing publications that users recognise and abide by the legal requirements associated with these rights.

- Users may download and print one copy of any publication from the public portal for the purpose of private study or research.
- You may not further distribute the material or use it for any profit-making activity or commercial gain
- You may freely distribute the URL identifying the publication in the public portal -

Take down policy

If you believe that this document breaches copyright please contact us at vbn@aub.aau.dk providing details, and we will remove access to the work immediately and investigate your claim.

Article

Reliability Analysis of Fatigue Failure of Cast Components for Wind Turbines

Hesam Mirzaei Rafsanjani * and John Dalsgaard Sørensen

Department of Civil Engineering, Aalborg University, Aalborg 9200, Denmark;

E-Mail: jds@civil.aau.dk

* Author to whom correspondence should be addressed; E-Mail: hmr@civil.aau.dk;

Tel.: +45-9940-8557.

Academic Editor: Frede Blaabjerg

Received: 23 December 2014 / Accepted: 7 April 2015 / Published: 15 April 2015

Abstract: Fatigue failure is one of the main failure modes for wind turbine drivetrain components made of cast iron. The wind turbine drivetrain consists of a variety of heavily loaded components, like the main shaft, the main bearings, the gearbox and the generator. The failure of each component will lead to substantial economic losses such as cost of lost energy production and cost of repairs. During the design lifetime, the drivetrain components are exposed to variable loads from winds and waves and other sources of loads that are uncertain and have to be modeled as stochastic variables. The types of loads are different for offshore and onshore wind turbines. Moreover, uncertainties about the fatigue strength play an important role in modeling and assessment of the reliability of the components. In this paper, a generic stochastic model for fatigue failure of cast iron components based on fatigue test data and a limit state equation for fatigue failure based on the SN-curve approach and Miner's rule is presented. The statistical analysis of the fatigue data is performed using the Maximum Likelihood Method which also gives an estimate of the statistical uncertainties. Finally, illustrative examples are presented with reliability analyses depending on various stochastic models and partial safety factors.

Keywords: wind turbine; drivetrain; fatigue; stochastic model; reliability analysis

1. Introduction

Wind energy is a rapid growing industry in the renewable energy sector with large the potential to contribute significantly to future energy production. A main focus for wind turbine manufacturers and operators is how to increase the reliability of wind turbines and to decrease their cost. Hence, cheaper and more efficient wind turbine components have to be developed to have an optimal balance between initial costs related to required reliability level on the one hand and the cost of operation and maintenance on the other hand. In order to perform this optimization, it is important to be able to estimate the reliability of the components.

Wind turbines, depending on whether placed in offshore or onshore locations, are exposed to wave excitations, highly dynamic wind loads and the wakes from other wind turbines. Therefore, most components in a wind turbine experience highly dynamic and time-varying loads. These components may fail due to wear or fatigue and this can lead to unplanned shutdown repairs that are very costly. The design of mechanical components in the wind turbine drivetrain by deterministic methods using safety factors is generally unable to account for the many uncertainties. Thus, a reliability assessment should be based on probabilistic methods where stochastic modeling of failures is performed.

The most common drivetrain configuration consists of the main shaft, the main bearings, the gearbox and the generator, see [1]. Modeling of the reliability of drivetrain component failures is important for predicting the expected time-to-failure which is an important indicator to be used in planning of operation and maintenance. In order to estimate the probability of failure of the drivetrain components careful modeling of the aleatory (physical) and epistemic (model, statistical and measurement) uncertainties has to be performed, see e.g., [2,3].

The reliability of wind turbine gearboxes has been studied in a number of research projects, e.g., the Gearbox Reliability Collaboration (GRC) project at the U.S. National Renewable Energy Laboratory (NREL) [4]. This includes important research areas on fault diagnosis and condition monitoring. Several methods have been investigated, such as vibration and acoustic emissions [5] and local mean decomposition [6]. Some studies on probabilistic modeling of failures in wind turbine drivetrain components have been carried out, e.g., [7,8] but without a detailed stochastic modeling of the uncertainties related to the parameters in the limit state equations modeling each failure mode.

This paper focuses on probabilistic models and the stochastic modeling of fatigue lives in the wind turbine drivetrain using structural reliability methods, see [9], allowing a rational modeling of all uncertainties. An important aspect in modeling fatigue failure of large cast steel components is to take into account scale effects. Two approaches are considered in this paper for stochastic modeling of the fatigue life including scale effects. One method is based on the classical Weibull approach and the other on application of a log-normal distribution as done, e.g., for the fatigue life of welded steel details. The statistical parameters in both models are estimated and applied in reliability assessments.

2. Wind Turbine Drivetrain

The drivetrain of a wind turbine converts the low-speed, high-torque rotation of the turbine's rotor (blades and hub assembly) into electrical energy. The most common drivetrain configuration consists

of the main shaft, the main bearings, the gearbox and the generator, see [1] and [10]. Typically, all individual components of the drivetrain are mounted onto the bedplate (Figure 1).

The main bearing, the main shaft and the gearbox have the highest downtime in case of failures, see e.g., [2,11]. Cyclic and variable loads excite these components during their service life and consequently fatigue is one of the main sources of failure of these components.

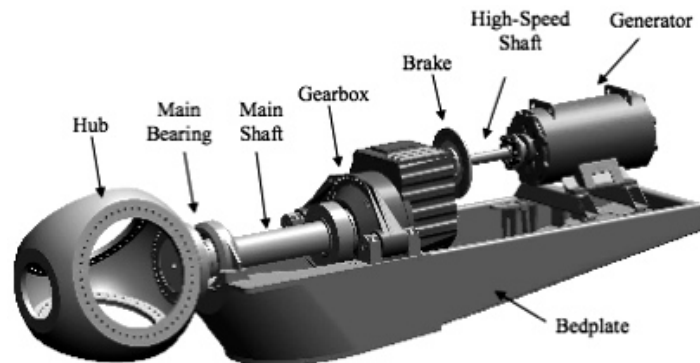

Figure 1. Modular configuration of wind turbine drivetrain components [10].

The current fatigue design is based on the life design approach [8]. In the safe life design, fatigue testing is carried out on baseline material to produce SN curves. However, the fatigue strength is highly uncertain and statistical uncertainties due to a limited number of tests can be important to include in modeling the fatigue strength. Moreover, model uncertainties related to e.g., application of the Miner rule for fatigue damage accumulation should be included in the probabilistic model.

3. Fatigue Strength Modeled by a Log-Normal Distribution

Fatigue failures typically occur due to the application of fluctuating stresses much lower than the stress required to cause failure during a single application of the stress. The fatigue life is the number of cycles to failure at a specified stress level, while the fatigue strength is the stress level below which failure does not occur for the given number of cycles. As the applied stress level decreases, the number of cycles to failure increases. The fatigue strength of metals is often assumed to follow the Basquin equation (the equation is based on fully reversed fatigue ($R = -1$), and the mean value is zero) [12]:

$$\sigma_a = \sigma_f (2N)^{-\frac{1}{m}} \quad (1)$$

where σ_a is the alternating stress amplitude, σ_f is the fatigue strength coefficient, N is the number of load cycle, and $1/m$ is the fatigue strength exponent.

The probability of failure increases when the volume of the component increases due to scale effects and because the probability of finding a critical micro-crack increases [8]. Thus the geometrical size effect affects the resistance of materials against fatigue failure. Hence, σ_a is affected by geometrical size effects and can be modeled by the following equation, see e.g., [8]. According to this Equation (1) can be written as [13]:

$$N = \frac{1}{2} \left(\frac{\sigma_{a0}}{\sigma_f} \right)^{-m} \left(\frac{V}{V_0} \right)^{\frac{1}{b_n}} = \frac{1}{2} \left(\frac{\sigma_{a0}}{\sigma_f} \right)^{-m} s_V^{\frac{1}{b_n}} \quad (2)$$

where V_0 is the reference volume and σ_{a0} is the alternative fatigue strength amplitude corresponding to reference volume of V_0 . The exponent b_n determines the effect of the specimen size on the fatigue life and V is the volume of component. In a log-log format Equation (2) is linear and can be rewritten introducing an uncertainty term ε , see [13]:

$$\log N = m \log \sigma_f - m \log \sigma_{a0} + \frac{1}{b_n} \log s_V - \log(2) + \varepsilon \tag{3}$$

where ε is assumed to be normal distributed with mean value = 0 and standard deviation = σ_ε . ε models the scatter in fatigue life and can be considered here to cover both physical and model uncertainties related to imperfect knowledge or idealizations of the mathematical models used or uncertainty related to the choice of probability distribution types for the stochastic variables. It is noted that the test data applied in the example below do not allow a bilinear SN curve to be fitted; but the above model can easily be extended to model a bi-linear SN curve and a lower threshold.

The parameters in (3) can be estimated using available test data. In this paper, test data extracted from Shirani [14] are used to exemplify the procedure for the stochastic modeling. Assuming that the Shirani data are representative the results of the statistical analysis can also be used to assess the reliability level for drivetrain components and to calibrate safety factors, see below.

In the following, the Maximum Likelihood Method is used for the statistical analysis. The log-likelihood function as a function of the statistical parameters σ_f , m , and σ_ε to be estimated is written as follows accounting both for tests results where failure occurs and test results where failure does not occur (run-outs) (note, the uncertainty related to σ_f and m model statistical uncertainties and ε models model uncertainty):

$$L(\sigma_f, m, \sigma_\varepsilon) = \prod_{i=1}^{n_F} P \left[\log n_i = m \log \sigma_f - m \log \sigma_{a0,i} + \frac{1}{b_n} \log s_V + \varepsilon - \log 2 \right] \\ \times \prod_{i=1}^{n_R} P \left[\log n_i > m \log \sigma_f - m \log \sigma_{a0,i} + \frac{1}{b_n} \log s_V + \varepsilon - \log 2 \right] \tag{4}$$

where n_i is the number of stress cycles to failure or run-out (no failure) with stress range equal to $\sigma_{a0,i}$ in test number i . n_F is the number of tests where failure occurs, and n_R is the number of tests where failure does not occur after n_i stress cycles (run-outs). $n = n_F + n_R$ is the total number of tests. σ_f , m , and σ_ε are estimated solving the optimization problem: $\max L(\sigma_f, m, \sigma_\varepsilon)$. This can be done using a standard nonlinear optimizer, e.g., the NLPQL algorithm, see [15].

Since the parameters σ_f , m and σ_ε are estimated by the maximum-likelihood technique, they become asymptotically (number of data should be larger than 25–30) normally distributed stochastic variables with expected values equal to maximum-likelihood estimates and covariance matrix equal to, see [16]:

$$C_{\sigma_f, m, \sigma_\varepsilon} = \left[-H_{\sigma_f, m, \sigma_\varepsilon} \right]^{-1} = \begin{bmatrix} \sigma_{\sigma_f}^2 & \rho_{\sigma_f, m} \sigma_{\sigma_f} \sigma_m & \rho_{\sigma_f, \sigma_\varepsilon} \sigma_{\sigma_f} \sigma_{\sigma_\varepsilon} \\ \rho_{\sigma_f, m} \sigma_{\sigma_f} \sigma_m & \sigma_m^2 & \rho_{m, \sigma_\varepsilon} \sigma_m \sigma_{\sigma_\varepsilon} \\ \rho_{\sigma_f, \sigma_\varepsilon} \sigma_{\sigma_f} \sigma_{\sigma_\varepsilon} & \rho_{m, \sigma_\varepsilon} \sigma_m \sigma_{\sigma_\varepsilon} & \sigma_{\sigma_\varepsilon}^2 \end{bmatrix} \tag{5}$$

where $H_{\sigma_f, m, \sigma_\tau}$ is the Hessian matrix with second-order derivatives of the log-likelihood function. σ_{σ_f} , σ_m and σ_{σ_τ} denote the standard deviation of σ_f , m and σ_τ respectively and $\rho_{..}$ indicates correlation coefficients. Alternatively to the log-normal model for the SN curve a Weibull model can be used, as described in the next section.

4. Fatigue Strength Modeled by a Weibull Distribution

As mentioned above, the strength of wind turbine drivetrain components are subject to uncertainties and therefore a stochastic modeling of life distribution is needed to study the reliability of the components. The influence of scale effects on damage modeling and fatigue life can from a theoretical basis be modeled by a Weibull mode, see e.g., [9]. Hence, the fatigue life can be modeled by a Weibull distribution for number of cycles to failure, N given stress range σ_{a0} is written as:

$$F_N(n) = 1 - \exp\left[-\left(\frac{n}{N(\sigma_{a0})}\right)^{b_n}\right] \tag{6}$$

where b_n is a shape parameter. By substituting Equation (2) in Equation (6), the corresponding density function becomes [13]:

$$f_N(n) = \frac{2b_n}{S_V^{1/b_n}} \left(\frac{\sigma_{a0}}{\sigma_f}\right)^m \left(\frac{2n}{S_V^{1/b_n}} \left(\frac{\sigma_{a0}}{\sigma_f}\right)^m\right)^{b_n-1} \exp\left[-\left(\frac{2n}{S_V^{1/b_n}} \left(\frac{\sigma_{a0}}{\sigma_f}\right)^m\right)^{b_n}\right] \tag{7}$$

The statistical parameters σ_f and m in Equation (7) can be estimated by the maximum-likelihood method with the likelihood function:

$$\begin{aligned} \ln L(\sigma_f, m) &= \ln\left(\prod_{i=1}^n f_N(n_i)\right) = \sum_{i=1}^{n_F} \ln\left[\frac{2b_n}{S_V^{1/b_n}} \left(\frac{\sigma_{a0,i}}{\sigma_f}\right)^m \left(\frac{2n_i}{S_V^{1/b_n}} \left(\frac{\sigma_{a0,i}}{\sigma_f}\right)^m\right)^{b_n-1} \exp\left[-\left(\frac{2n_i}{S_V^{1/b_n}} \left(\frac{\sigma_{a0,i}}{\sigma_f}\right)^m\right)^{b_n}\right]\right] \\ &+ \sum_{i=1}^{n_R} \ln\left[\exp\left[-\left(\frac{2n_i}{S_V^{1/b_n}} \left(\frac{\sigma_{a0,i}}{\sigma_f}\right)^m\right)^{b_n}\right]\right] \end{aligned} \tag{8}$$

where n_i , n_F , n_R and n are introduced in previous section and they are obtained solving the optimization problem $\max L(\sigma_f, m)$, see above.

5. Characteristic Values

In deterministic approaches, code-based design safety is introduced through application of deterministic values in terms of characteristic values and safety factors to obtain design values of both loads and strengths. In the following a probabilistic basis is used to estimate the characteristic values by modeling of physical, measurement, statistical and model uncertainties.

If statistical uncertainty is not taken into account then corresponding to a stress range, $\sigma_{a0,c}$ a characteristic value of the fatigue life, n_c defined as the 5% quantile can be estimated directly from the distribution function of the fatigue life.

If statistical uncertainty is to be taken into account and the physical/model uncertainties for the fatigue life are modeled by a log-normal distribution then the characteristic value for the fatigue life, n_c corresponding to the stress range, $\sigma_{a0,c}$ defined as a 5% quantile can be obtained from by:

$$P\left(\log n_c > m \log \sigma_f - m \log \sigma_{a0,c} + \frac{1}{b_n} \log s_V + \varepsilon - \log 2\right) = 0.05 \quad (9)$$

with a corresponding limit state equation written as:

$$g(\sigma_f, m, \varepsilon, \sigma_\varepsilon) = m \log \sigma_f - m \log \sigma_{a0,c} + \frac{1}{b_n} \log s_V + \varepsilon - \log 2 - \log n_c \quad (10)$$

Here, ε , m , σ_ε and σ_f are modeled as stochastic variables as described above. For given $\sigma_{a0,c}$ Equation (10) can be solved with respect to the characteristic fatigue life, n_c using e.g., First Order Reliability Methods (FORM, see [9]).

Similarly, if the fatigue life is modeled by a Weibull distribution and statistical uncertainty is accounted for, and then the characteristic value can be estimated using the following limit state equation:

$$g(\sigma_f, m, \varepsilon, \sigma_\varepsilon) = \log n_c + \log 2 - \frac{1}{b_n} \log s_V + m \log \sigma_{a0,c} - m \log \sigma_f - \log(-\ln(0.95))^{1/b_n} - \varepsilon \quad (11)$$

In equation (11), ε , σ_ε , m and σ_f model the physical/model and statistical uncertainties, respectively. As mentioned before, these parameters can be obtained from test results.

6. Reliability Analysis

Reliability of a component can be defined as the probability that the component under consideration has a proper performance throughout its lifetime. Structural reliability methods can be used to estimate the probability of failure/reliability which next can be used for decision-making, e.g., with respect to design or planning of inspections, maintenance and repair.

The reliability estimated as a measure of the safety of a structure can be used in a decision process (for example Markov decision process [17]). A lower level of the acceptable reliability can be used as a constraint in a reliability-based optimal design problem. The lower level of the reliability can be obtained by analyzing similar structures designed after current design practice or it can be determined as the reliability level giving the largest utility (benefits-costs) when solving a decision problem where all possible costs and benefits in the expected lifetime of the structure are taken into account. Further, the reliability and failure rate of components can be used for decision making for maintenance plans [18].

Drivetrain components are typically exposed to complex loading conditions, [12]. Often the fatigue load is due to a range of fluctuating loads, different mean stress levels and variable frequencies. Cumulative damage theories consider the fatigue process to be one of damage accumulation until the life of the component is exhausted. Cumulative damage during fatigue is often modeled by using the

Palmgren-Miner rule, which assumes that the total life of a part can be estimated by adding up the percentage of life consumed by each stress level [12] and can be written as follows if used in a deterministic code-based verification:

$$D = \sum_i \frac{n_{i,S} T_L}{N_{0;0.05} \left(\frac{\sigma_{a0,i}}{z}, \frac{\sigma_f}{\gamma_m} \right)} = 1 \quad (12)$$

where $n_{i,S}$ represent the number of cycles per year at a specific stress level $\sigma_{a0,i}$ and T_L is the design lifetime. It is assumed that for a wind turbine component the total number of stress ranges for a given fatigue critical detail can be grouped in n_σ groups/intervals such that the number of stress ranges in group i is $n_{i,S}$ per year. $(\sigma_{a0,i}, n_{i,S})$ can be obtained by rain-flow counting and can be represented by so-called ‘Markov matrices’. Further, $N_{0;0.05} \left(\frac{\sigma_{a0,i}}{z}, \frac{\sigma_f}{\gamma_m} \right)$ is the 5% quantile of the number of cycles to failure given fatigue load equal to $\sigma_{a0,i}/z$ and given the design fatigue strength σ_f/γ_m . $N_{0;0.05}$ can be obtained both without and with statistical uncertainty included. z is a design / scaling parameter, e.g., related to a cross-sectional parameter; γ_m is a partial safety factor for fatigue.

In this paper, the Level II method is used to measure the reliability of the components [9]. The design parameter z is obtained from (12) assuming that a fatigue partial safety factor γ_m is given. Thereby the reliability analyses become normalized in the way that the reliability is linked to the partial safety factors and it is assumed that the structure is designed to the limit though the design parameter z in the design equation. The corresponding limit state equation to be used in the reliability analysis is written:

$$g(t) = \Delta - \sum_i \frac{n_{i,S} t}{N_{0;0.05} \left(\frac{X_W X_{SCF} \sigma_{a0,i}}{z}, \sigma_f \right)} \quad (13)$$

where t is time (in years), Δ models model uncertainty related to Miner’s rule for linear damage accumulation. The distribution function for number of cycles to failure, $N_{0;0.05}$ for given stress $\sigma_{a,i}$ can be obtained by equations (10) and (11) for log-normal and Weibull distributed fatigue lives. If statistical uncertainty is included then the statistical parameters are modeled by stochastic variables. X_W is a stochastic variable modeling model uncertainty related to determination of fatigue loads and X_{SCF} is a stochastic variable modeling model uncertainty related to determination of stresses given fatigue loads. For wind turbines the fatigue loads are typically estimated for mean wind speeds from 4 m/s to 25 m/s and are normally represented by time series of load effects or equivalently by Markov matrices obtained by rain-flow counting. In the example below these loads are extracted from simulated loads for the main shaft of a 5 MW wind turbine for each mean wind speed V_j . The hub diameter is 3 meter and the rotor has a diameter of 126 meter. The hub height is 90 meter. The cut-in and cut-out wind speeds are 3 m/s and 25 m/s, respectively. Further information can be found in reference [19].

Based on the geometry of the component (main shaft) and the load matrices, the stress amplitudes have been calculated. The calculated values are not fully reversed stress amplitude. Hence, the Goodman equation is used to find the effective fully reversed stress amplitudes for each mean speed.

Equation (12) is thus rewritten:

$$D = \sum_{V_j} \left(\sum_i \frac{n_{i,S,j} T_L}{N_{0;0.05} \left(\frac{\sigma_{a0,i,j}}{z}, \frac{\sigma_f}{\gamma_m} \right)} \right) * P(V_j) = 1 \tag{14}$$

where, V_j is the mean wind speed and $P(V_j)$ is probability of occurrence of this mean wind speed, modelled by a Weibull distribution according to IEC 61400-1 [20]. In the example below, the scale and shape parameters of Weibull distribution have been chosen to 11.48 [m/s] and 1.75, respectively [21]. By substituting Equation (14) in Equation (13), the limit state equation can be written:

$$g(t) = \Delta - \sum_{V_j} \left(\sum_i \frac{n_{i,S,j} t}{N_{0;0.05} \left(\frac{X_W X_{SCF} \sigma_{a0,i,j}}{z}, \sigma_f \right)} \right) * P(V_j) \tag{15}$$

In Equation (15), Δ , X_W and X_{SCF} are assumed to be log-normal distributed with mean values equal 1 and coefficients of variation COV_Δ , COV_W and COV_{SCF} , respectively, following the recommendations in [22]. The coefficient of variations are estimated based partly subjectively, but following generally the recommendations used as basis for the material partial safety factors in IEC 61400-1, and also considering information from e.g., DNV-RP-C203 [23] although this is not directly related to the fatigue problem considered in this paper. The importance of the choices of the coefficient of variations is investigated by sensitivity analyses. It is noted that the reliability level obtained is in accordance with the target reliability corresponding to an annual probability of failure of the order 5×10^{-4} (annual reliability index: 3.3) [20].

Table 1 shows the representative stochastic model. Expected values and coefficient of variations for m and σ_f are extracted from tests results as described above. Based on Equation (15), the probability of failure in the time interval $[0,t]$ can be estimated by FORM/SORM techniques or simulation, see e.g., [9]. The reliability index, $\beta(t)$ corresponding to the accumulated probability of failure $P_F(t)$ is defined by:

$$\beta(t) = -\Phi^{-1}(P_F(t)) \tag{16}$$

where $\Phi()$ is the standardized normal distribution function. The annual probability of failure conditioned on survival up to time t is obtained from:

$$\Delta P_F(t) = (P_F(t - \Delta t) - P_F(t)) / \Delta t / (1 - P_F(t)) \tag{17}$$

where Δt is a time increment, typically 1 year. The reliability index, $\Delta\beta$ corresponding to the probability ΔP_F is denoted the annual reliability index when $\Delta t = 1$ year.

Table 1. Stochastic model.

Variable	Definition	Distribution	Expected Value	Coefficient of variation
Δ	Model uncertainty related to Miner's rule	LN *	1	0.2
X_{SCF}	Model uncertainty related to determination of stresses given fatigue load	LN	1	0.05
X_W	Model uncertainty related to determination of fatigue loads	LN	1	0.1
m	Statistical uncertainty	N **	Extracted from test results	
σ_f [MPa]	Statistical uncertainty	N	Extracted from test results	

* LN: Log-normal distribution; ** N: Normal distribution.

7. Results

As mentioned above the test data by Shirani [14] will be used to illustrate the above statistical analysis and reliability assessment for wind turbine drivetrain components. The test data follows the specifications listed in Table 2. Two series of specimens were machined from T95 block (the cast block dimensions were 750 mm × 200 mm × 95 mm), and T150 block (the cast block dimensions were 150 mm × 300 mm × 150 mm), specimens with 21 mm diameter. Specimens were tested at load ratios

$$R = -1 \text{ (with } R \text{ defined by } R = \frac{\sigma_{\min}}{\sigma_{\max}} = \frac{\sigma_m - \sigma_a}{\sigma_m + \sigma_a} \text{) [14].}$$

Table 2. The test plan [14].

Material	Load Ratio	Specimen [mm]	Number of specimens	Test frequency [Hz]
T95	-1	Ø21	12	10
T150	-1	Ø21	18	10

The statistical analysis is performed following the methodology described in section 3 and 4 for estimation of the parameters in the log-normal and Weibull models. The results using the log-normal distribution model (Equations (6) and (7)) are shown in Table 3.

Table 3. Estimated statistical parameters from tests with log-normal model for fatigue life.

Test	σ_f [MPa]		m		σ_ε	
	Mean	Std dev	mean	Std dev	mean	Std dev
D21 T95 R = -1	941	50.5	9.4	0.33	0.25	0.01
D21 T150 R = -1	697	67.9	10.7	0.83	0.23	0.04

As mentioned in Table 2, the tests “D21 T95 R = -1” and “D21 T150 R = -1” are done with the same frequency and the same load ratio. Hence, these two tests can be used to study the changes of volume/size effects on the fatigue strength. Moreover, the correlation matrixes of the statistical parameters for these two tests are shown below for illustration.

$$\text{Correlation matrix} = \begin{bmatrix} \sigma_{\sigma_f}^2 & \rho_{\sigma_f,m} \sigma_{\sigma_f} \sigma_m & \rho_{\sigma_f,\sigma_\varepsilon} \sigma_{\sigma_f} \sigma_{\sigma_\varepsilon} \\ \rho_{\sigma_f,m} \sigma_{\sigma_f} \sigma_m & \sigma_m^2 & \rho_{m,\sigma_\varepsilon} \sigma_m \sigma_{\sigma_\varepsilon} \\ \rho_{\sigma_f,\sigma_\varepsilon} \sigma_{\sigma_f} \sigma_{\sigma_\varepsilon} & \rho_{m,\sigma_\varepsilon} \sigma_m \sigma_{\sigma_\varepsilon} & \sigma_{\sigma_\varepsilon}^2 \end{bmatrix} = \begin{bmatrix} 1 & -0.96 & 0.21 \\ -0.96 & 1 & -0.17 \\ 0.21 & -0.17 & 1 \end{bmatrix} \quad \text{Test D21 T95}$$

R=-1

$$\text{Correlation matrix} = \begin{bmatrix} \sigma_{\sigma_f}^2 & \rho_{\sigma_f,m} \sigma_{\sigma_f} \sigma_m & \rho_{\sigma_f,\sigma_\varepsilon} \sigma_{\sigma_f} \sigma_{\sigma_\varepsilon} \\ \rho_{\sigma_f,m} \sigma_{\sigma_f} \sigma_m & \sigma_m^2 & \rho_{m,\sigma_\varepsilon} \sigma_m \sigma_{\sigma_\varepsilon} \\ \rho_{\sigma_f,\sigma_\varepsilon} \sigma_{\sigma_f} \sigma_{\sigma_\varepsilon} & \rho_{m,\sigma_\varepsilon} \sigma_m \sigma_{\sigma_\varepsilon} & \sigma_{\sigma_\varepsilon}^2 \end{bmatrix} = \begin{bmatrix} 1 & -0.99 & 0.07 \\ -0.99 & 1 & -0.06 \\ 0.07 & -0.06 & 1 \end{bmatrix} \quad \text{Test D21 T150}$$

R=-1

It is seen that σ_f and m are highly negative correlated (as expected). Next, the statistical uncertainties of fitted parameters using the Weibull distribution to model the fatigue life are extracted using the Maximum Likelihood Method. The results are shown in Table 4.

Table 4. Estimated statistical parameters from tests with Weibull model for fatigue life.

Test	σ_f [MPa]		m	
	mean	Std dev	mean	Std dev
D21 T95 R = -1	979	8.18	9.2	0.05
D21 T150 R = -1	686	5.76	10.9	0.07

Figures 2 and 3 show the mean and characteristic SN curves with log-normal and Weibull distributions for the fatigue life for tests “D21 T95 R = -1” and “D21 T150 R = -1” and with statistical uncertainties included. The figures show that the difference between the Weibull and log-normal models is small.

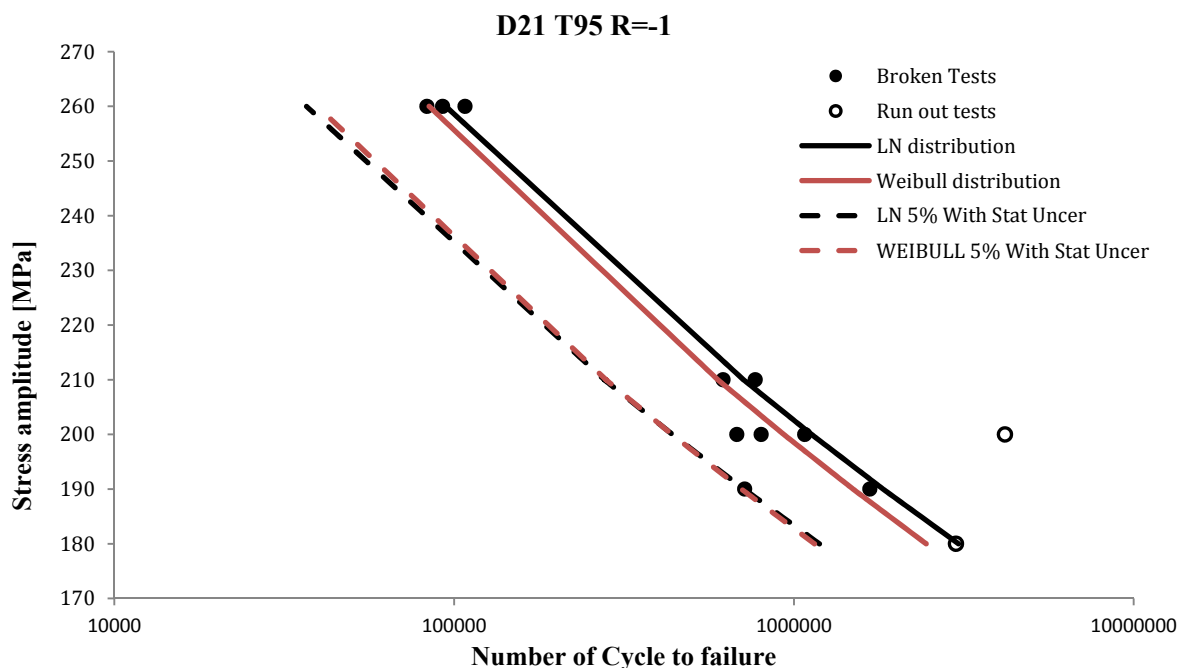

Figure 2. SN data for test D21 T95 R = -1 with fitted mean and characteristic SN curves.

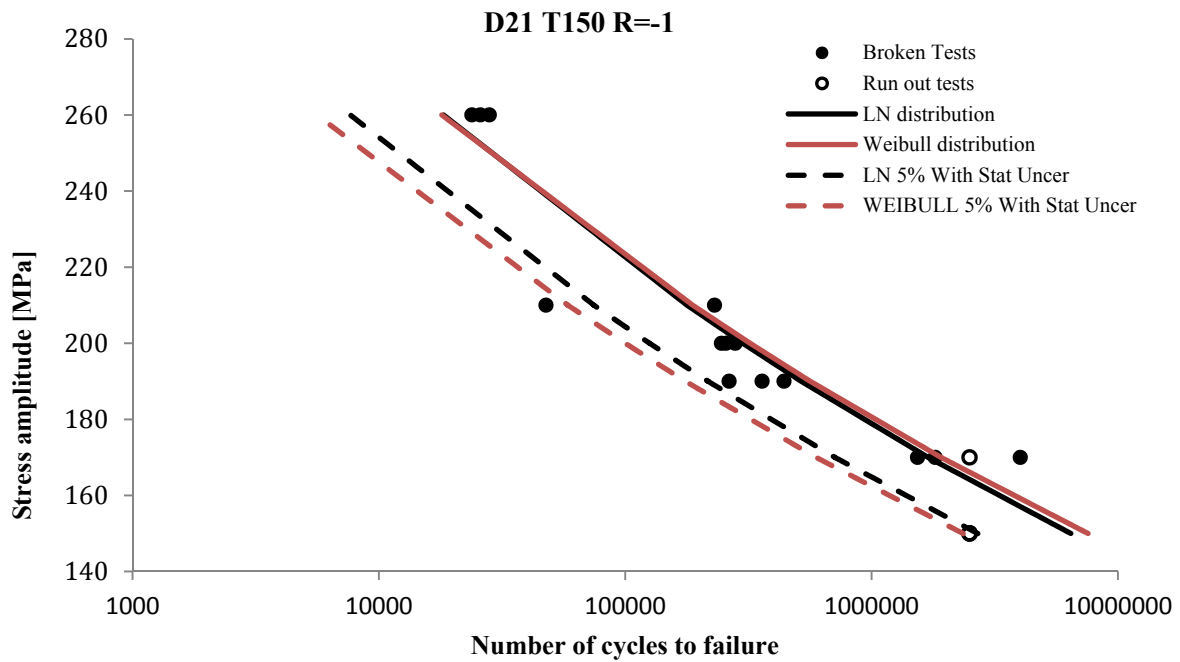

Figure 3. SN data for test D21 T150 R = -1 with fitted mean and characteristic SN curves.

Next, using these estimated statistical parameters, the annual reliability index is estimated. First, the reliability index is determined with the partial safety factor, γ_m varying between 1.5 and 2, see Figures 4 and 5. It is seen that the Weibull distribution model has the lowest sensitivity with respect to changes of the partial safety factor when compared to log-normal distribution model. The target reliability level for wind turbines is typically in the interval from 3.1 to 3.8 for the annual reliability index corresponding to annual probabilities of failure between 10^{-4} and 10^{-3} . From Figure 4, it is seen as expected that when the partial safety factor increases, the reliability index increases.

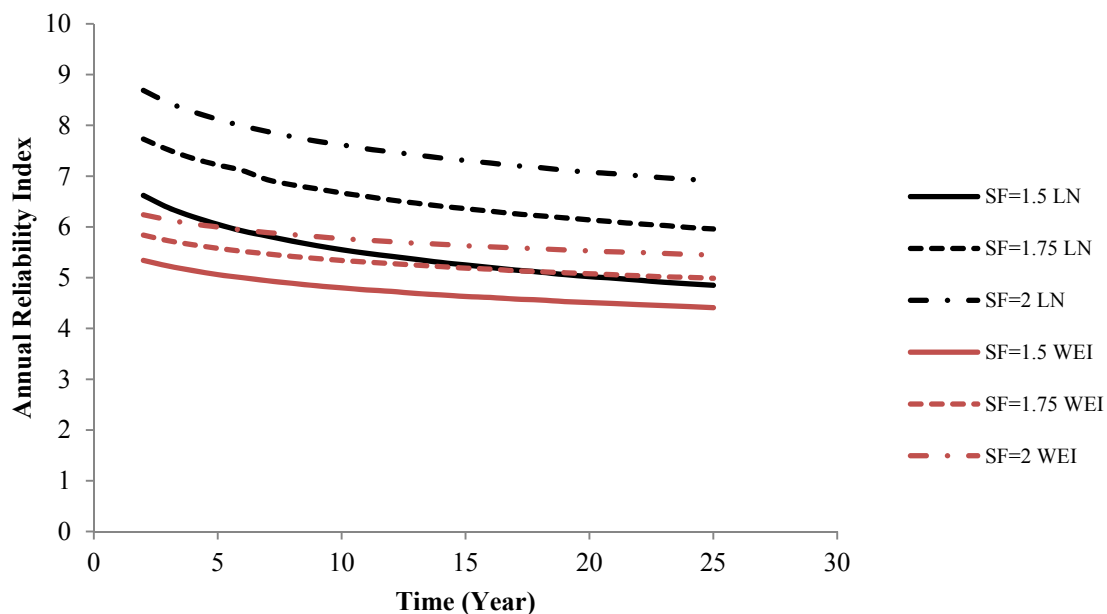

Figure 4. Annual reliability index for partial safety factor $\gamma_m = 1.5, 1.75$ and 2.0 using the Weibull and log-normal models. Test D21 T95 R = -1.

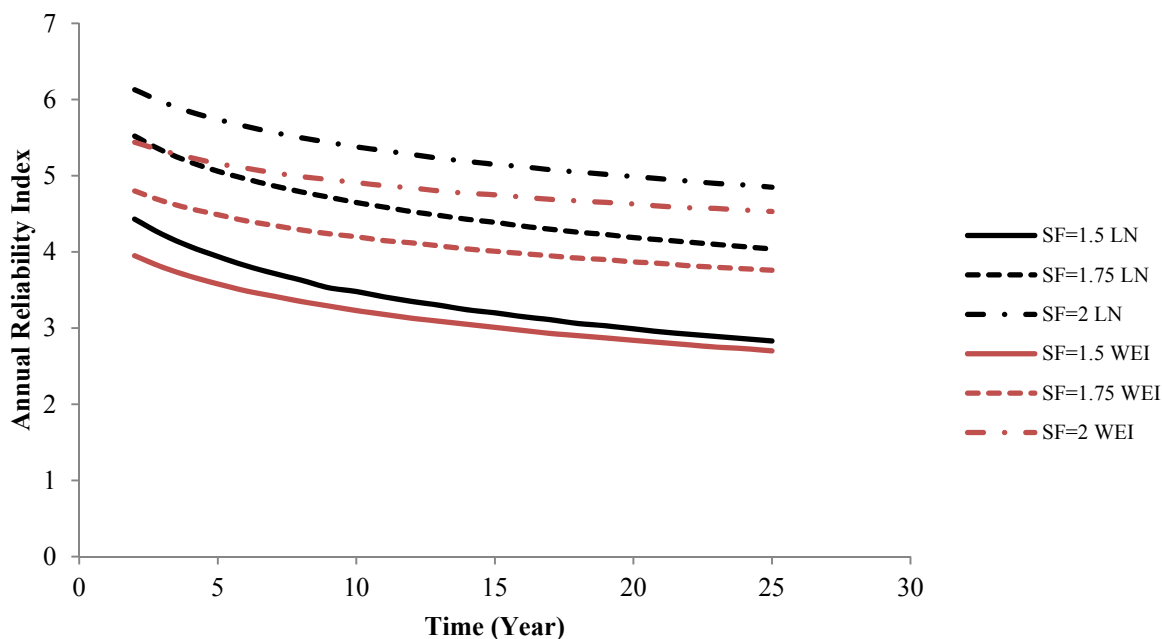

Figure 5. Annual reliability index for partial safety factor $\gamma_m = 1.5, 1.75$ and 2.0 using the Weibull and log-normal models. Test D21 T150 R = -1.

Next, the sensitivity of the reliability with respect to the uncertainty level of X_W and X_{SCF} is investigated. The partial safety factor, γ_m equal to 1.75 is used in all the following cases. The results for X_W are shown in Figures 6 and 7. It is seen that when the uncertainty related to the fatigue loads increases, then the reliability index based on the log-normal distribution model decrease more than the reliability index based on the Weibull distribution model. It is also seen that the reliability index is quite sensitive to the coefficient of variation of X_W .

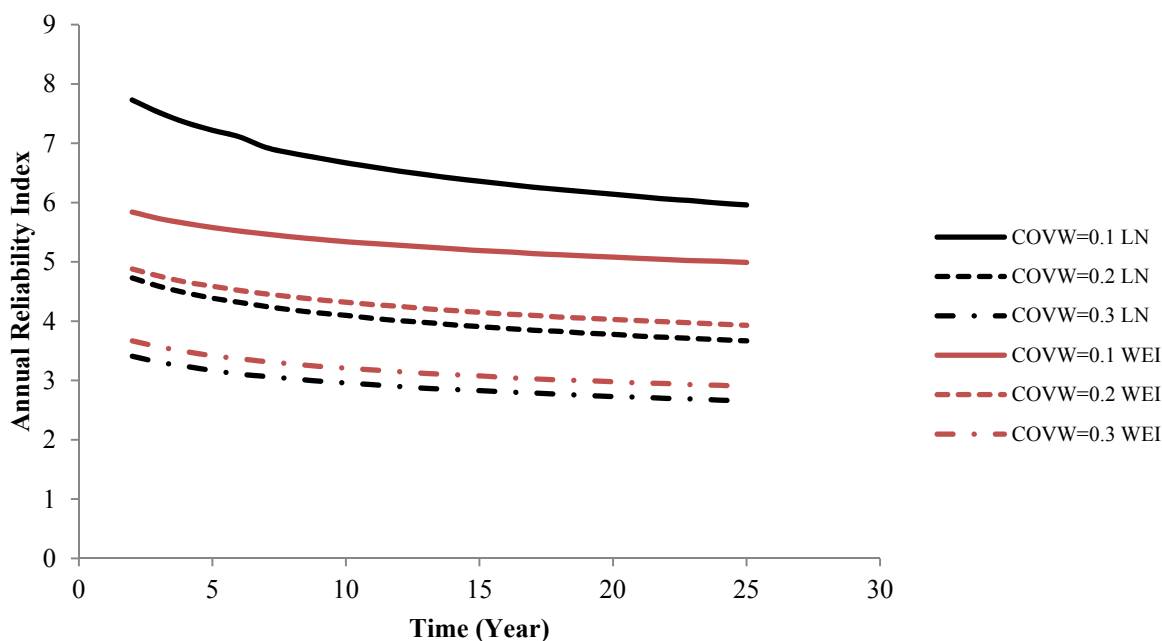

Figure 6. Annual reliability index for different uncertainty models for X_W . Test D21 T95 R = -1.

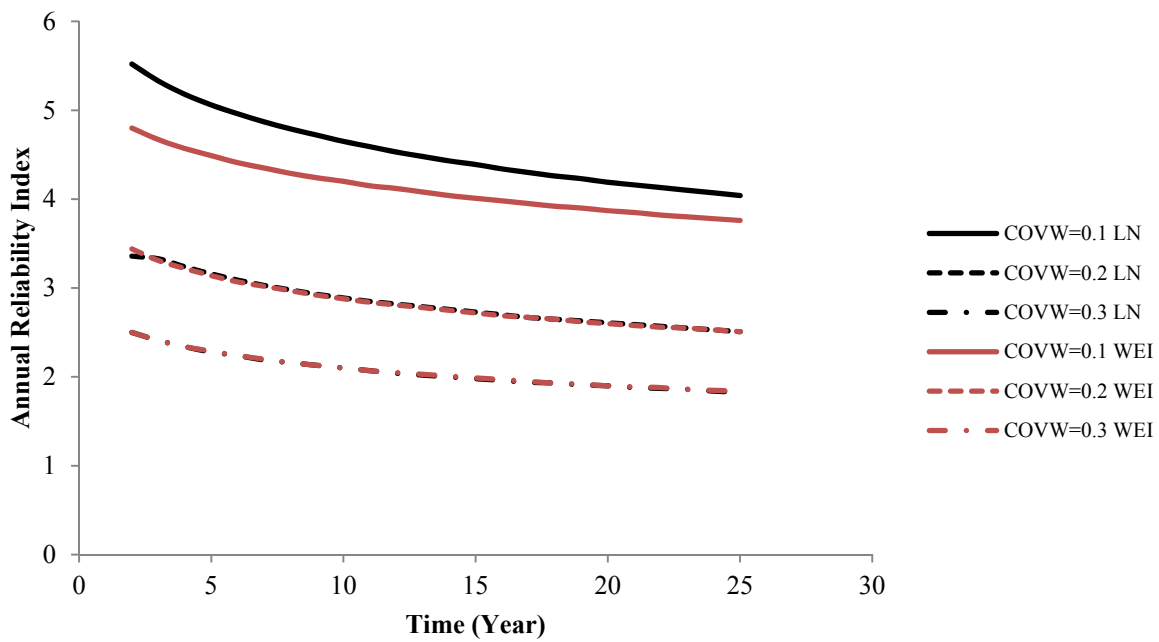

Figure 7. Annual reliability index for different uncertainty models for X_W . Test D21 T150 R = -1.

Next, the influence of the uncertainty of X_{SCF} is investigated. Figures 8 and 9 show the results for the coefficient of variation of X_{SCF} equal to 0.05, 0.15 and 0.25. The results are similar to those obtained for X_W . Furthermore, the geometrical size effect affects the resistance of the material against fatigue failure. As mentioned above, the results of “D21 T95 R = -1” and “D21 T150 R = -1” are used as basis for investigating the geometrical size effects.

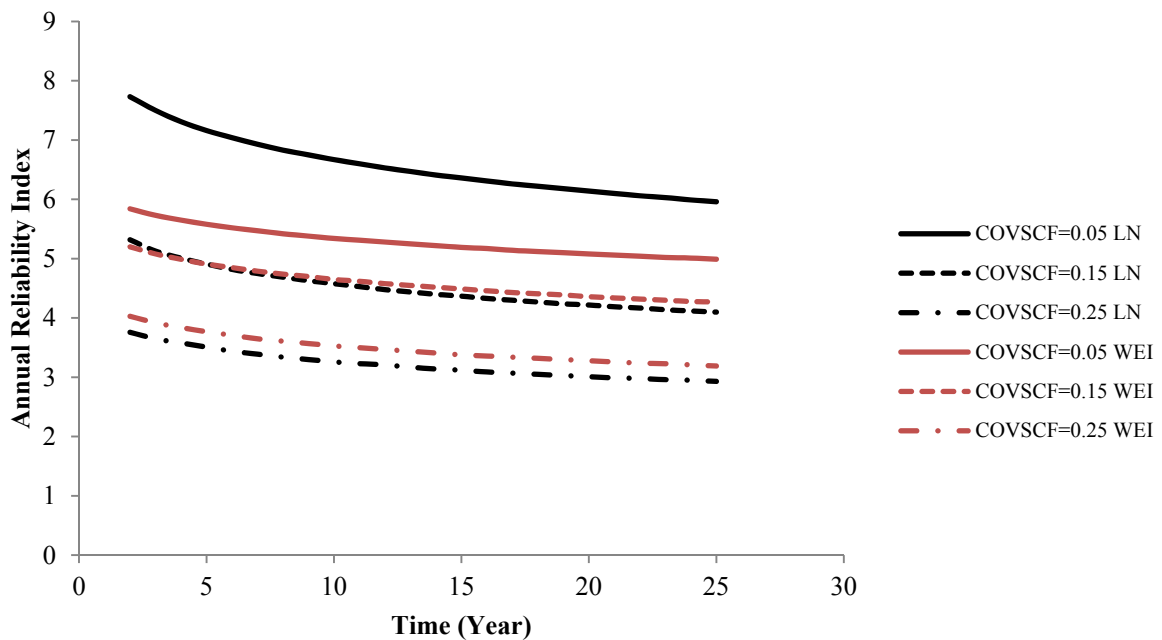

Figure 8. Annual reliability index for different uncertainty models for X_{SCF} . Test D21 T95 R = -1.

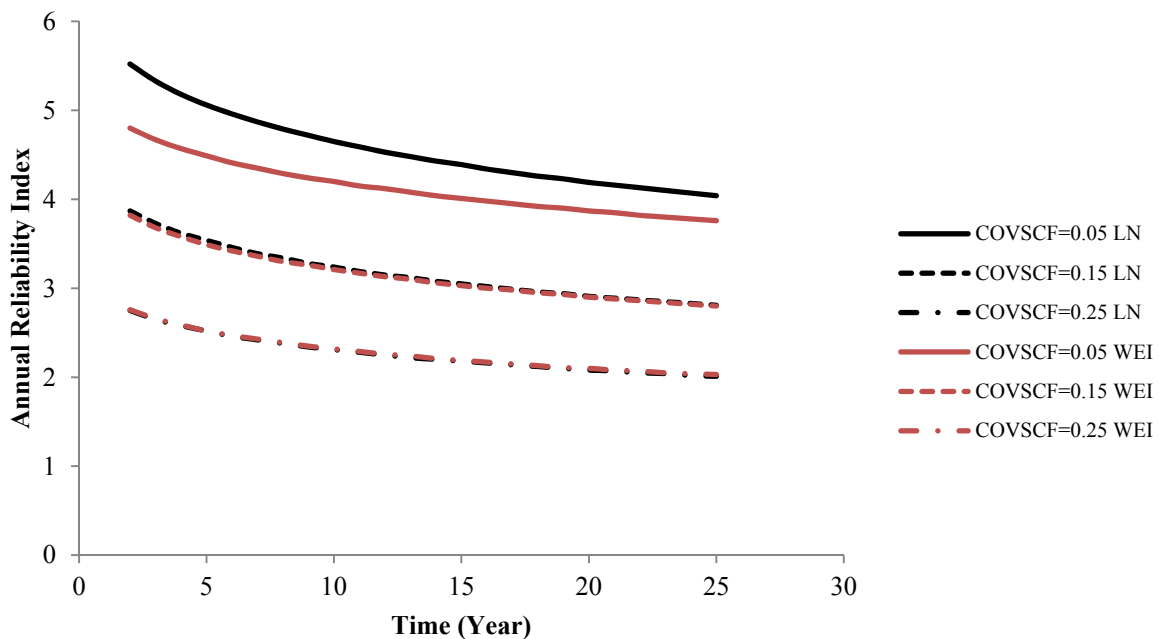

Figure 9. Annual reliability index for different uncertainty models for X_{SCF} . Test D21 T150 R = -1.

By comparing Figures 2 and 3, the fatigue life of specimen “D21 T95 R = -1” is higher than the fatigue life of “D21 T150 R = -1” and it is seen that when the volume of a component increase, the fatigue life of the component decrease. This effect is important to include in reliability assessments. Moreover, by comparing the Figures 6,7 and Figures 8,9 for various assumptions of the uncertainties of X_W and X_{SCF} , it is seen that the annual reliability index of T150 is (as expected) lower than T95 in all cases. Consequently, higher safety factor must be applied in the design process for larger components and the geometrical size effect may affect the design significantly.

8. Conclusions

In this paper, different stochastic models for fatigue failure of casted steel components in wind turbine drivetrain components are considered. Firstly, the fatigue life is modeled and various uncertainties that affect the stochastic models of failure are described including size effects. These uncertainties include model and statistical uncertainties. The basic uncertainty of the fatigue life is modeled by two distribution models, namely log-normal and Weibull distribution. It is described how the statistical parameters can be derived including the statistical uncertainties. Next, characteristic SN -curves are derived using structural reliability techniques.

A set of test data is used to illustrate the procedure to rationally model the uncertainties and next to estimate the reliability for generic cases. The results indicate that the characteristic SN -curves are almost the same using the Weibull and log-normal models, but the reliability obtained by the log-normal distribution model is generally higher than reliability index obtained using the Weibull distribution model. Further, the uncertainty of the load model is seen to influence the reliability level significantly. The same is the case for the size effect. This implies that safety factors used in deterministic design should reflect these uncertainties. This effect is not studied in this paper but will be done in future work.

Acknowledgments

The work is supported by the Strategic Research Center “REWIND—Knowledge based engineering for improved reliability of critical wind turbine components”, Danish Research Council for Strategic Research, grant no. 10-093966.

Author Contributions

All the authors contributed to the data collection, analysis, and paper write up.

Conflicts of Interest

The authors declare no conflict of interest.

References

1. Hau, E. *Wind Turbines: Fundamentals, Technologies, Application, Economics*, 2nd ed.; Springer: New York, NY, USA, 2006.
2. Sheng, S.; Veers, P. Wind turbine drivetrain condition monitoring—an overview. In Proceedings of the Mechanical Failures Prevention Group: Applied Systems Health Management Conference 2011, Virginia Beach, VA, USA, 10–12 May 2011.
3. Mirzaei Rafsanjani, H.; Sørensen, J.D. Stochastic modeling of wind turbine drivetrain components. In *Safety, Reliability and Risk Analysis: Beyond the Horizon*; Proceedings of the European Safety and Reliability Conference, Amsterdam, The Netherlands, 29 September–2 October 2013; Steenbergen, R.D.J.M., van Gelder, P.H.A.J.M., Miraglia, S., Vrouwenvelder, A.C.W.M., Eds.; CRC Press LLC: Leiden, The Netherlands, 2013; pp. 1221–1228.
4. Link, H.; LaCava, W.; Van Dam, J.; McNiff, B.; Sheng, S.; Wallen, R.; McDade, M.; Lambert, S.; Butterfield, S.; Oyague, F. *Gearbox Reliability Collaborative Project Report: Findings from Phase 1 and Phase 2 Testing*; Technical Report NREL/TP-5000-51885; National Renewable Energy Laboratory: Golden, CO, USA, 2011.
5. Soua, S.; Lieshout, P.V.; Perera, A.; Gan, T.; Bridge, B. Determination of the combined vibrational and acoustic emission signature of a wind turbine gearbox and generator shaft in service as a pre-requisite for effective condition monitoring. *Renew. Energy* **2013**, *51*, 175–181.
6. Liu, W.Y.; Zhang, W.H.; Han, J.G.; Wang, G.F. A new wind turbine fault diagnosis method based on the local mean decomposition. *Renew. Energy* **2012**, *48*, 411–415.
7. Dong, W.; Xing, Y.; Moan, T.; Gao, Z. Time domain-based gear contact fatigue analysis of a wind turbine drivetrain under dynamic conditions. *Int. J. Fatigue* **2013**, *48*, 133–146.
8. Shirani, M.; Härkegård, G. Fatigue life distribution and size effect in ductile cast iron for wind turbine components. *Eng. Fail. Anal.* **2011**, *18*, 12–24.
9. Madsen, H.O.; Krenk, S.; Lind, N.C. *Methods of Structural Safety*; Prentice-Hall: Englewood Cliffs, NJ, USA, 1986.
10. Oyague, F. *Gearbox Modeling and Load Simulation of a Baseline 750-kW Wind Turbine Using State-of-the-Art Simulation Codes*; Technical Report NREL/TP-500-41160; National Renewable Energy Laboratory: Golden, CO, USA, 2011.

11. Tavner, P.J.; Greenwood, D.M.; Whittle, M.W.G.; Gindele, R.; Faulstich, S.; Hahn, B. Study of weather and location effects on wind turbine failure rates. *Wind Energy* **2012**, *16*, 175–187.
12. Campbell, F.C. *Elements of Metallurgy and Engineering Alloys*; ASM International: Materials Park, OH, USA, 2008.
13. Mirzaei Rafsanjani, H.; Sørensen, J.D. Stochastic models of defects in wind turbine drivetrain components. In *Multiscale Modeling and Uncertainty Quantification of Materials and Structures*; Proceedings of the IUTAM Symposium, Santorini, Greece, 9–11 September 2013.
14. Shirani, M.; Härkegård, G. Casting defects and fatigue behavior of ductile cast iron for wind turbine components: A comprehensive study. *Mater. Werkst.* **2011**, *42*, 1059–1074.
15. Schittkowski, K. NLPQL: A fortran subroutine solving constrained nonlinear programming problems. *Ann. Oper. Res.* **1986**, *5*, 485–500.
16. Lindley, D.V. *Introduction to Probability and Statistics from a Bayesian Viewpoint*; Cambridge University Press: Cambridge, UK, 1976.
17. Byon, E.; Ding, Y. Season-dependent condition-based maintenance for a wind turbine using a partially observed Markov decision process. *IEEE Trans. Power Syst.* **2010**, *25*, 1823–1834.
18. Byon, E.; Ntamo, L.; Ding, Y. Optimal maintenance strategies for wind turbine systems under stochastic weather conditions. *IEEE Trans. Reliab.* **2010**, *59*, 393–404.
19. Definition of a 5-MW Reference Wind Turbine for Offshore System Development. Available online: <http://www.nrel.gov/docs/fy09osti/38060.pdf> (accessed on 13 April 2015).
20. *Wind Turbines—Part 1: Design Requirements*; IEC: Geneva, Switzerland, 2015; CD IEC 61400-1 ed. 4.
21. Petersen, E.L.; Mortensen, N.G.; Landberg, L.; Højstrup, J.; Frank, H.P. *Wind Power Meteorology*; Risø National Laboratory: Roskilde, Denmark, 1997; Risø-I-1206(EN).
22. Wirsching, P.H. Fatigue reliability for offshore structures. *J. Struct. Eng. (ASCE)* **1984**, *10*, 2340–2356.
23. *Fatigue Design of Offshore Steel Structures*; DNV: Høvik, Norway, 2010; DNV-RP-C203.

© 2015 by the authors; licensee MDPI, Basel, Switzerland. This article is an open access article distributed under the terms and conditions of the Creative Commons Attribution license (<http://creativecommons.org/licenses/by/4.0/>).