

Renal drug metabolism in humans: the potential for drug–endobiotic interactions involving cytochrome P450 (CYP) and UDP-glucuronosyltransferase (UGT)

Kathleen M. Knights, Andrew Rowland & John O. Miners

Department of Clinical Pharmacology, School of Medicine, Faculty of Health Sciences, Flinders University, Adelaide, South Australia, Australia

Correspondence

Professor Kathleen Knights PhD,
Department of Clinical Pharmacology,
School of Medicine, Flinders University,
Bedford Park, Adelaide 5042, Australia.
Tel.: +618 8204 4331
Fax: +61 8204 5114
E-mail: kathie.knights@flinders.edu.au

Keywords

arachidonic acid, cytochrome P450, drug metabolism, human kidney, hydroxyeicosatetraenoic acids, UDP-glucuronosyltransferase

Received

15 December 2012

Accepted

23 January 2013

Accepted Article Published Online

31 January 2013

Although knowledge of human renal cytochrome P450 (CYP) and UDP-glucuronosyltransferase (UGT) enzymes and their role in xenobiotic and endobiotic metabolism is limited compared with hepatic drug and chemical metabolism, accumulating evidence indicates that human kidney has significant metabolic capacity. Of the drug metabolizing P450s in families 1 to 3, there is definitive evidence for only CYP 2B6 and 3A5 expression in human kidney. CYP 1A1, 1A2, 1B1, 2A6, 2C19, 2D6 and 2E1 are not expressed in human kidney, while data for CYP 2C8, 2C9 and 3A4 expression are equivocal. It is further known that several P450 enzymes involved in the metabolism of arachidonic acid and eicosanoids are expressed in human kidney, CYP 4A11, 4F2, 4F8, 4F11 and 4F12. With the current limited evidence of drug substrates for human renal P450s drug–endobiotic interactions arising from inhibition of renal P450s, particularly effects on arachidonic acid metabolism, appear unlikely. With respect to the UGTs, 1A5, 1A6, 1A7, 1A9, 2B4, 2B7 and 2B17 are expressed in human kidney, whereas UGT 1A1, 1A3, 1A4, 1A8, 1A10, 2B10, 2B11 and 2B15 are not. The most abundantly expressed renal UGTs are 1A9 and 2B7, which play a significant role in the glucuronidation of drugs, arachidonic acid, prostaglandins, leukotrienes and P450 derived arachidonic acid metabolites. Modulation by drug substrates (e.g. NSAIDs) of the intrarenal activity of UGT1A9 and UGT2B7 has the potential to perturb the metabolism of renal mediators including aldosterone, prostaglandins and 20-hydroxyeicosatetraenoic acid, thus disrupting renal homeostasis.

Introduction

'The kidneys are of a glandular nature, but redder in colour, like the liver, . . . Their cavities are small and like sieves, for the percolation of the urine. . . .' Aretaeus, the Cappadocian, 1st century BC [1].

The kidneys carry out a number of highly integrated functions that include maintenance of body fluid (composition and volume), electrolytes and acid-base balance, regulation of blood pressure via orchestrated changes in sodium balance and the synthesis and secretion of renin,

along with the production of vasoactive eicosanoids, the synthesis of erythropoietin and 1,25-dihydroxyvitamin D₃ and the excretion of polar chemicals and metabolites, the latter arising from both xenobiotic and intermediary metabolism.

Despite evidence of significant endogenous synthetic and catabolic capacity, in terms of drug metabolism the general assumption has been (is) that the metabolic clearance of drugs is determined principally, if not exclusively, by the liver while the kidneys contribute minimally to the metabolic clearance of drugs. The contribution of the

kidney to drug metabolic clearance is generally predicted to be less than that of liver given the lower organ weight and microsome yield of the kidneys [2]. However, *in vitro*–*in vivo* extrapolation of kinetic data is not possible in the absence of a valid model of renal metabolic clearance. Nevertheless, there is now a wealth of *in vitro* and *in vivo* data clearly demonstrating that human kidney has significant drug metabolizing capacity that in some instances surpasses that of liver [3]. For example, the intrinsic clearance (CL_{int}) of the glucuronidated substrates mycophenolic acid and 4-methylumbelliferone by human kidney microsomes are comparable with those of human liver microsomes [4, 5]. Additionally, the maximal rate of propofol glucuronidation by human kidney microsomes is 3–4 times greater than that of human liver microsomes [6, 7]. Not surprisingly, total systemic clearance of propofol in humans has been reported to exceed hepatic blood flow [8]. Further data from *in vivo* studies in humans demonstrated extrahepatic elimination of propofol in liver transplant patients during the anhepatic stage [9, 10] and identified the kidneys as contributing almost one-third of total systemic clearance [11]. Similar to propofol the systemic clearance of morphine in humans has been reported to exceed hepatic clearance by 38%. The authors concluded that in the absence of evidence of gut wall metabolism it could be reasonably concluded that the site of extrahepatic metabolism in humans was the kidney [12].

Clearly the kidneys, in addition to their traditional role of excreting a myriad of xenobiotics, xenobiotic metabolites and metabolites of intermediary metabolism, possess significant xenobiotic metabolizing capacity. The human kidneys express an array of enzymes variably involved in xenobiotic metabolism (e.g. *N*-acetyltransferases, sulfotransferases and glutathione transferases) [3]. However, this review will focus on cytochrome P450 (CYP) and UDP-glucuronosyltransferases (UGT), enzymes that are integral to systemic and intrarenal clearance of both endo- and xeno-biotics, including drugs.

Human cytochrome P450

Human cytochrome P450 exists as a superfamily of haem containing enzymes that catalyze the oxidative metabolism of a myriad of compounds. Indeed, P450 catalyzed pathways serve as a key clearance mechanism, as well as terminating the actions of a range of endogenous and exogenous compounds including drugs from all therapeutic classes (Table 1), steroid hormones, eicosanoids, cholesterol, vitamins, fatty acids and bile acids [13].

There are 60 known human P450 genes, which are classified into 18 gene families and 43 subfamilies on the basis of sequence identity [14]. Enzymes of the CYP1, CYP2 and CYP3 families are primarily responsible for the metabolism of drugs and other non-drug xenobiotics [13], while enzymes from the remaining P450 families play key roles in

Table 1

Representative major substrates of human drug metabolizing cytochrome P450 enzymes

Enzyme	Representative major substrates
CYP1A2	Caffeine, clozapine, dacarbazine, leflunomide, lignocaine, tacrine, theophylline
CYP2A6	Nicotine
CYP2B6*	Bupropion, cyclophosphamide, efavirenz, ifosfamide, ketamine, propofol
CYP2C8†	Amodiaquine, chloroquine, paclitaxel, repaglinide, rosiglitazone
CYP2C9†	Losartan, NSAIDs (e.g. celecoxib, diclofenac, flurbiprofen, ibuprofen), oral hypoglycaemics (e.g. gliclazide, glibenclamide, glimepiride, glipizine, tolbutamide), phenytoin, torasemide, <i>S</i> -warfarin
CYP2C19	Citalopram, escitalopram, nelfinavir, PPIs (e.g. esomeprazole, lansoprazole, omeprazole, pantoprazole), proguanil, voriconazole
CYP2D6	Dextromethorphan, desipramine, fluoxetine, nortriptyline, perhexiline, tramadol, venlafaxine
CYP2E1	Enflurane, halothane
CYP3A4†/5*	Carbamazepine, calcium channel blockers (e.g. diltiazem, felodipine, nifedipine, verapamil), cyclosporin, HIV protease inhibitors (e.g. indinavir, lopinavir, ritonavir), ifosfamide, midazolam, statins (e.g. atorvastatin, simvastatin), tacrolimus, triazolam, tyrosine kinase inhibitors (e.g. dasatinib, lapatinib, sorafenib, sunitinib)

*Expressed in human kidney. †Evidence for expression in human kidney equivocal.

the synthesis and metabolism of endogenous compounds. In this regard, individual P450 enzymes exhibit distinct, but overlapping, patterns of substrate and inhibitor selectivity [15, 16]. The tertiary structures of several human P450 enzymes, including CYP1A2, 2A6, 2C8, 2C9, 2D6 and 3A4, have been elucidated by X-ray crystallography in recent years and the amino acids that form the substrate binding pocket identified [17–20].

Substrates of human renal P450s

In terms of the human kidney knowledge of P450s and the role they play in both endo- and xeno-biotic metabolism is surprisingly lacking. In some instances the data are conflicting and in others, although purported to pertain to human kidney, the primary data often relates to rat, rabbit and mouse kidney. In 1972 the first study characterizing P450 activity using human kidney cortical microsomes reported not only metabolism of aminopyrine via demethylation but a comparable rate of ω- and ω-1 hydroxylation of lauric acid [21]. P450 mediated metabolism of arachidonic acid (AA, C20:4) using rabbit kidney cortical microsomes was unequivocally demonstrated in 1981 with identification of 19- and 20-hydroxyeicosatetraenoic acids (19-, 20-HETE) [22]. Subsequently, Karara *et al.* reported that homogenates of post-mortem human kidney cortex contained 8,9 epoxyeicosatrienoic acid (8,9-EET), 11,12-EET

and 14,15-EET, the latter constituting 44% of the total concentration of EETs. The authors concluded that EETs were 'endogenous constituents of human kidney cortex generated *in vivo* by the tissue arachidonic acid epoxygenase' and that in view of the biological activity of EETs P450s controlled renal function [23]. Using human kidney cortical microsomes, again prepared from post-mortem renal tissue, the formation of 19-HETE, 20-HETE and 11,12-EET was reported by Schwartzman *et al.* [24].

Thereafter, the relevance of and interest in renal xenobiotic metabolism and AA metabolism languished while work continued to focus on hepatic P450s and the cyclooxygenase (COX) and lipoxygenase (LOX) enzymes involved in the metabolism of AA. The focus on AA metabolism changed in the mid-1990s following recognition of the physiological and biochemical importance of AA derived metabolites in the modulation of cardiac, pulmonary, renal and vascular function, and inflammation and angiogenesis [25, 26]. The AA cascade includes three main pathways;

(i) metabolism by COX generates the unstable cyclic endoperoxide prostaglandin H₂ (PGH₂), an obligatory intermediate in the formation of PGE₂, PGF_{2 α} , PGD₂, PGI₂ (prostacyclin) and thromboxane (TXA₂), (ii) the LOX pathway generates several allylic hydroperoxides containing a *cis-trans* conjugated diene functionality such as 5-hydroperoxyeicosatetraenoic acid (5-HPETE), which is the precursor to the formation of the leukotrienes and (iii) the P450 pathway. The latter involves metabolism of AA by a number of different types of reactions:

- bis-allylic oxidation (LOX-like reaction) generating six regioisomeric HETEs, 5-, 8-, 9-, 11-, 12- and 15-HETE,
- hydroxylation ($\omega/\omega-1$ hydroxylase) at or near the terminal carbon to form 16-HETE ($\omega-4$), 17-HETE ($\omega-3$), 18-HETE ($\omega-2$), 19-HETE ($\omega-1$) and 20-HETE (ω) and
- olefin epoxidation (AA epoxygenase) generating four regioisomeric EETs, 5,6-, 8,9-, 11,12- and 14,15-EET.

P450s, both hepatic and renal, that variously play a key role in the metabolism of xenobiotics and fatty acids include enzymes of the CYP1A, 2B, 2C, 2D, 2E, 2J, 3A, 4A, 4B and 4F sub-families [26]. However, the number of studies that have specifically investigated P450 mediated xenobiotic and fatty acid metabolism using human kidney are limited and, moreover, it is apparent that extrapolation from animals to humans is problematic. Of the studies that have used human kidney, and acknowledging issues such as antibody specificity and sensitivity of the techniques used (e.g. Northern blots, immunoblotting, activity assays), it has been reported that CYP 2B6, 3A5, 4A11, 4F2, 4F8, 4F11 and 4F12 are expressed in human kidney [27–30]. While expression of CYP 1A1, 1A2, 1B1, 2A6, 2C19, 2D6, and 2E1 has not been reported in human kidney (see later sections), the data regarding CYP 2C8, 2C9, 3A4 and 2J2 are equivocal.

Table 2

Formation of fatty acid metabolites by recombinant or purified P450 enzymes

Enzyme	Metabolites*	Reference
CYP1A2	11-HODE (17%); 7-, 10-, 13-, 19-HETE	[39]
CYP2C8†	11-HODE (8%); 11-, 13-, 15-HETE; 11,12-, 14,15-EET	[39] [40]
CYP2C9†	11-HODE (5%); 12-, 13-HETE; 8,9-, 11,12-, 14,15-EET	[39] [40]
CYP2C19	11-HODE (4%), 19-HETE	[39]
CYP2E1	19-HETE	[41]
CYP2J2†	5,6- (21%), 8,9- (24%); 11,12- (18%), 14,15-EET (37%)	[38]
CYP3A4†	11-HODE (28%), 7-, 10-, 13-HETE	[39]

*Number in brackets indicates the percentage of total production of individual metabolites. †Evidence of expression in human kidney equivocal.

A cDNA coding for CYP2C8 was isolated from a human kidney library and the expressed protein catalyzed formation of 11,12- and 14,15-EET (Table 2). However, use of a sequence specific oligonucleotide for CYP2C8 in Northern blot analyses failed to detect mRNA transcripts encoding CYP2C8 [31]. Subsequent studies either combining Northern blot analysis and immunoblotting [32] or using immunoblotting alone did not report the presence of CYP2C8 mRNA or expression of CYP2C8 protein in human kidney [30]. In contrast, using immunohistochemistry and a semi-quantitative scoring of staining intensity, CYP2C8 protein expression was reported in normal human kidney tissues in ~50% of the individual tissues studied [33]. Definitive determination of either the presence or absence of CYP2C8 in human kidney remains unresolved.

In addition to a role in drug metabolism (e.g. paclitaxel 6 α -hydroxylation) CYP2C8 is the primary hepatic enzyme responsible for the formation of 11,12- and 14,15-EET and is thought to contribute substantially to the systemic concentration of circulating EETs [32]. Genetic polymorphism of CYP2C8 was identified in 2001 and the polymorphic alleles CYP2C8*2 and CYP2C8*3 were associated with markedly deficient metabolism of both paclitaxel and AA. It was concluded that not only were there clinical ramifications in terms of paclitaxel elimination but also with regard to the diminished production of physiologically relevant EETs that function as autocrine and paracrine mediators [34].

Similarly the data regarding expression of CYP2C9 [27, 30], CYP3A4 [27, 30, 35–37] and CYP2J2 [33, 38] in human kidney are equivocal, although the weight of evidence suggests that CYP2C9 is not present. The data regarding expression of CYP3A4 in human kidney are highly variable. Using Western blotting, Baker *et al.* [27] reported that CYP3A4 protein was not present in nine samples of kidney cortical microsomes. Again using immunoblotting

Table 3

Representative endobiotic substrates of human kidney P450 enzymes

Enzyme	Endobiotic substrates	Metabolites	Reference
CYP2B6	Fatty acids, steroids, retinoids	Quinols of estrone and 17 β -estradiol; 4-hydroxy-, 4-oxo-, and 18-hydroxy-retinoic acid; 6 β -hydroxyl metabolites of testosterone and 17 α -methyltestosterone	[43–45]
CYP3A5	Fatty acids, cortisol	19-HETE, 6 β -hydroxycortisol	[35, 41]
CYP4A11	Fatty acids	19-HETE, 20-HETE	[30, 49]
CYP4F2	Fatty acids, LTB ₄	20-HETE; 20-HETE-ethanolamide; 20-hydroxy-LTB ₄	[30, 49, 51]
CYP4F8	Fatty acids, prostaglandins	18-HETE; 19-hydroxy-PGH ₂ ; 18-hydroxy- and 19-hydroxy-PGH ₁	[52]
CYP4F11	Fatty acids, leukotrienes	8-HETE; 20-hydroxy-LTB ₄	[53]
CYP4F12	Fatty acids	18-HETE	[54]

CYP3A3/4 protein expression was reported in one out of seven [36] and six out of nine kidneys tested [37]. Further, CYP3A4 mRNA was reported in only 11 of 27 human kidney samples [35]. The significance of absent/variable CYP3A4 expression in human kidneys remains to be fully elucidated.

Conflicting data have been reported for CYP2J2 in that barely detectable levels of total RNA were reported for human kidney [38]. In contrast, an immunohistochemical study identified CYP2J2 protein expression in ~50% of the human kidney tissue samples analyzed [33]. Further, in those tissues where P450 catalyzes epoxygenation a relationship between the formation of EETs and CYP2J2 content was not established [30].

It is apparent that a number of P450s that are expressed in liver variously metabolize xenobiotics (with the exception of CYP2J2) and fatty acids, including the conversion of linoleic acid to 11-hydroxyoctadecadienoic acid (11-HODE) (Table 2) [39–41]. As has been previously reported in the literature, the liver appears to be the organ that predominately metabolizes AA to EETs [42]. This tenet is supported by evidence, albeit limited, of lack of expression of the relevant renal human P450s that metabolize AA to EETs. Thus, renal drug–endobiotic interactions involving CYP 1A2, 2C8, 2C9, 2C19, 2E1, 2J2 and 3A4 are unlikely. The P450s that are reported to be expressed in human kidney include CYP 2B6, 3A5, 4A11, 4F2, 4F8, 4F11 and 4F12 (Table 3) [43–54].

CYP2B6

CYP2B6 is a highly polymorphic enzyme that is known to contribute (3–12%) to the metabolism of therapeutic drugs (Table 1) [41]. In addition to the metabolism of drugs that include chemotherapeutics, anti-retrovirals, anti-inflammatories, anaesthetics and benzodiazepines [45], CYP2B6 also metabolizes environmental chemicals including insecticides, herbicides and a small number of industrial chemicals [46]. In terms of endogenous metabo-

lism, CYP2B6 catalyzes formation of the quinols of estrone and 17 β -estradiol [43], 4-hydroxy-, 4-oxo-, and 18-hydroxy-retinoic acid, which are the principal metabolites of all-trans-retinoic acid [44], and to a limited extent the 6 β -hydroxy metabolites of testosterone and 17 α -methyltestosterone [55]. Both Northern blot analysis and immunoblotting confirmed the presence of CYP2B6 mRNA and protein, respectively, in human kidney [56]. Further, using 7-ethoxy-4-fluoro-coumarin as a probe for CYP2B6 activity, Aleksa *et al.* reported 13-fold variability in activity in a panel of microsomes from 10 human kidneys [37].

CYP3A5

Using microsomes from 29 human kidneys the metabolism of midazolam to 1'-hydroxymidazolam was used to assess the activity of renal CYP3A4/3A5. Activity varied 134-fold and high activity was related to higher expression of CYP3A5 [35]. CYP3A4 protein was undetectable in the majority of the kidneys. CYP3A5 is expressed to a 1.5-fold greater extent in the cortex than in the medulla of human kidney [36] and immunostaining of CYP3A5 indicates localization in the apical membrane of the proximal and distal tubules [57].

Cortisol is metabolized by CYP3A5 to 6 β -hydroxycortisol which, in a variety of animal models, has been shown to cause salt retention and to enhance sodium transport suggesting a possible link with salt sensitive hypertension. A single nucleotide polymorphism (A6986G) in the CYP3A5 gene has been shown to distinguish either the (*1) 'expressor' allele or the (*3) 'reduced expressor' allele, which largely predicts CYP3A5 content in liver [58]. A subsequent comparative *in vitro*–*in vivo* study investigated a link between CYP3A5 genotype, CYP3A5 expression and blood pressure using tissue from 21 kidney donors and 25 healthy African-American adults. Renal microsomes from individuals carrying the *1/*3 alleles had >8-fold higher CYP3A5 content and 18-fold higher formation of 1'-hydroxymidazolam than microsomes from

individuals identified as homozygous for the *CYP3A5**3 alleles. Subsequent genotyping of the 25 African-American individuals indicated that the mean systolic blood pressure of individuals homozygous for *CYP3A5* *1 was raised by 19.3 mmHg in comparison with individuals homozygous for *CYP3A5* *3. This led the authors to speculate an association between the *CYP3A5* *1 genotype and salt sensitive hypertension in African-Americans [59]. However, the relationship between *CYP3A5* genotype and cortisol metabolism by human kidney has yet to be established.

The three primary metabolites of the calcineurin inhibitor cyclosporin, AM1, AM9 and AM4N are less nephrotoxic than the parent compound and hence metabolism is considered a detoxification process. Analogous to recombinant *CYP3A5*, human kidney microsomes produce only the AM9 metabolite and the extent of formation shows a significant association with *CYP3A5* content and presence of the *CYP3A5**1 allele [44]. With regard to tacrolimus, exposure of the renal epithelium to the drug in individuals carrying the *CYP3A5**1 alleles was 53% of that of carriers of the *CYP3A5**3 alleles, suggesting that *CYP3A5* genotype determines intrarenal accumulation of tacrolimus and its primary metabolites [60]. In addition, ifosfamide *N*-dechloroethylation was not detected using human kidney microsomes from *CYP3A5**3/*3 donors. In contrast, microsomes from *CYP3A5**1/*1 individuals catalyzed this pathway. Thus, a higher rate of renal metabolism of ifosfamide to the nephrotoxic metabolite, chloroacetaldehyde, is associated with the *CYP3A5**1 genotype [48].

CYP4A11 and CYP4F2

CYP4A11, first cloned from a human kidney cDNA library in 1993, catalyzes formation of 20-HETE [61], which plays a pivotal role in the regulation of renal vascular tone and the long term control of arterial pressure. Within the liver both *CYP4A11* and *CYP4F2* are responsible for 20-HETE formation. *CYP4F2* appears more physiologically relevant as the K_m (24 μM) for AA was nearly 10-fold lower than that of *CYP4A11* (K_m 228 μM) [49] and an antibody to *CYP4F2*, in contrast to a *CYP4A11* antibody, markedly inhibited 20-HETE formation [49]. In the same study, *CYP4A11* and *CYP4F2* expression was reported in human kidney cortex, consistent with a role for 20-HETE in controlling constriction of renal blood vessels [49]. Subsequent studies confirmed expression of *CYP4A11* and *CYP4F2* in the S2 and S3 segments of proximal tubules in both the cortex and outer medulla of human kidney. Neither P450 was found in glomeruli, loops of Henle or the collecting tubules [30]. Identification of 20-HETE as the major AA metabolite formed by human kidney cortical microsomes highlights the difference between AA metabolism in human liver and kidney and reflects the differing complements of P450s in these organs [30].

Recently the metabolism of the endocannabinoid anandamide was investigated using human kidney microsomes and recombinant *CYP4F2* and *CYP4A11* as the enzyme sources. *CYP4F2* was found to play a major role in the metabolism of anandamide to 20-HETE-ethanolamide. In contrast, *CYP4A11* exhibited negligible activity. Anandamide exhibited a lower apparent K_m (i.e. higher affinity) for *CYP4F2* (0.7 μM) than did AA. Although the significance of this route of metabolism of anandamide is unknown it raises the question of a potential intrarenal interaction between anandamide and AA [50]. In addition, the 'orphan' P450 enzyme *CYP4X1*, which is expressed in human kidney, metabolizes anandamide to the monooxygenated metabolite 14,15-EET-ethanolamide. *CYP4X1* also metabolizes AA to 14,15- and 8,9-EET to a minor extent, but the physiological significance of metabolism by *CYP4X1* remains to be established [62].

In addition to the metabolism of AA, purified human liver *CYP4F2* catalyzes the metabolism of leukotriene B₄ (LTB₄) to the less biologically active metabolite 20-hydroxy LTB₄. This metabolite was not formed by either *CYP2A6*, *CYP2C9* or *CYP4A11*. Inhibition (~92%) by an anti-*CYP4F2* antibody further suggested that *CYP4F2* is the predominant P450 that terminates biological activity of LTB₄ [51].

CYP4F8

CYP4F8, which was cloned originally from human seminal vesicular mRNA, catalyzes the formation of 18-HETE, 19-hydroxy-PGH₂, and 18- and 19-hydroxy-PGH₁ [52]. In contrast, PGD₂, PGE₁, PGE₂, PGF_{2 α} and LTB₄ were poor substrates [52]. The presence of *CYP4F8* mRNA and expression of *CYP4F8* protein has been demonstrated in proximal renal tubules of human kidney [63]. To date there is no information regarding xenobiotic substrates of *CYP4F8*.

CYP4F11

A cDNA encoding *CYP4F11* was first isolated from a human hippocampus library. Subsequent Northern blot analysis identified high levels of *CYP4F11* mRNA transcripts in human liver and kidney [64]. Studies using recombinant *CYP4F11* protein identified a range of endogenous and xenobiotic substrates. These include LTB₄, AA, lipoxin A₄ and 8-HETE. In contrast, lipoxin B₄, 5-HETE, PGA₁ and PGE₁ were not metabolized by ω -hydroxylation [53]. Of the xenobiotic substrates studied *CYP4F11* catalyzed the dealkylation of benzphetamine, erythromycin, ethylmorphine, imipramine, theophylline and verapamil, and to a lesser extent, amitriptyline, chlorpromazine and pirenzepine, but not fluoxetine *N*-demethylation [53]. These xenobiotics are also metabolized by a number of hepatic P450s (e.g. *CYP* 1A2, 2D6, 3A4). Clearly *CYP4F11* has broad

substrate selectivity and the potential physiological implications in terms of drug–eicosanoid interactions are yet to be investigated.

CYP4F12

Expression of CYP4F12 was detected in human kidney using RT-PCR and activity of the recombinant protein was investigated using AA, PGs and LTB₄ as substrates. CYP4F12 metabolized AA to one major metabolite, 18-HETE. In contrast, PGE₂, PGF_{2α} and LTB₄ were poor substrates for ω-hydroxylation [54]. Immunohistochemical analyses established that the vast majority of tissues did not contain CYP4F12. However, it was present in the human gut and the renal collecting tubules, but not proximal tubuli or renal cortex [65]. Catalytic studies identified lack of activity towards a number of long chain unsaturated fatty acids and prostaglandins (e.g. PGD₂ and PGI₂) [65]. Interestingly, however, recombinant CYP4F12 has been shown to exhibit activity towards the potent non-sedating H₁-receptor antagonist ebastine [66].

Perspective

Despite the wealth of literature on the P450 gene superfamily our knowledge of human renal P450s and their role

in both xenobiotic and endobiotic metabolism is limited compared with hepatic metabolism. This is particularly relevant considering the biological activity of the ω-hydroxylated metabolite 20-HETE, which is a potent vasoconstrictor of renal vasculature and serves as a major regulator of sodium reabsorption in the proximal tubule and thick ascending limb of the loop of Henle [42]. Moreover animal models of hypertension have identified a role for 20-HETE in the control of systemic blood pressure [42]. It has been stated that ‘members of the CYP2C and CYP4A gene subfamilies are the predominant and functionally relevant kidney AA epoxygenases and ω-hydroxylases, respectively’ [67]. However, the weight of evidence from studies that have investigated AA metabolism using human kidney and liver tissue indicates that the CYP2C enzymes involved predominantly in the formation of EETs are hepatic (Figure 1, Table 2). Too often, the presence of P450s in human kidney has been inferred from animal data. Indeed, reviews and other papers that cite P450 expression as occurring in human kidney often do so without reference to the primary data sources. This then raises the question that if EETs are predominantly formed in the liver in humans, then any renal action must arise after delivery to and release from storage sites within the kidney.

It appears that CYP4A11 and CYP4F2 are the principal renal enzymes involved in 20-HETE formation in humans (Figure 1, Table 3). However, to date no xenobiotic

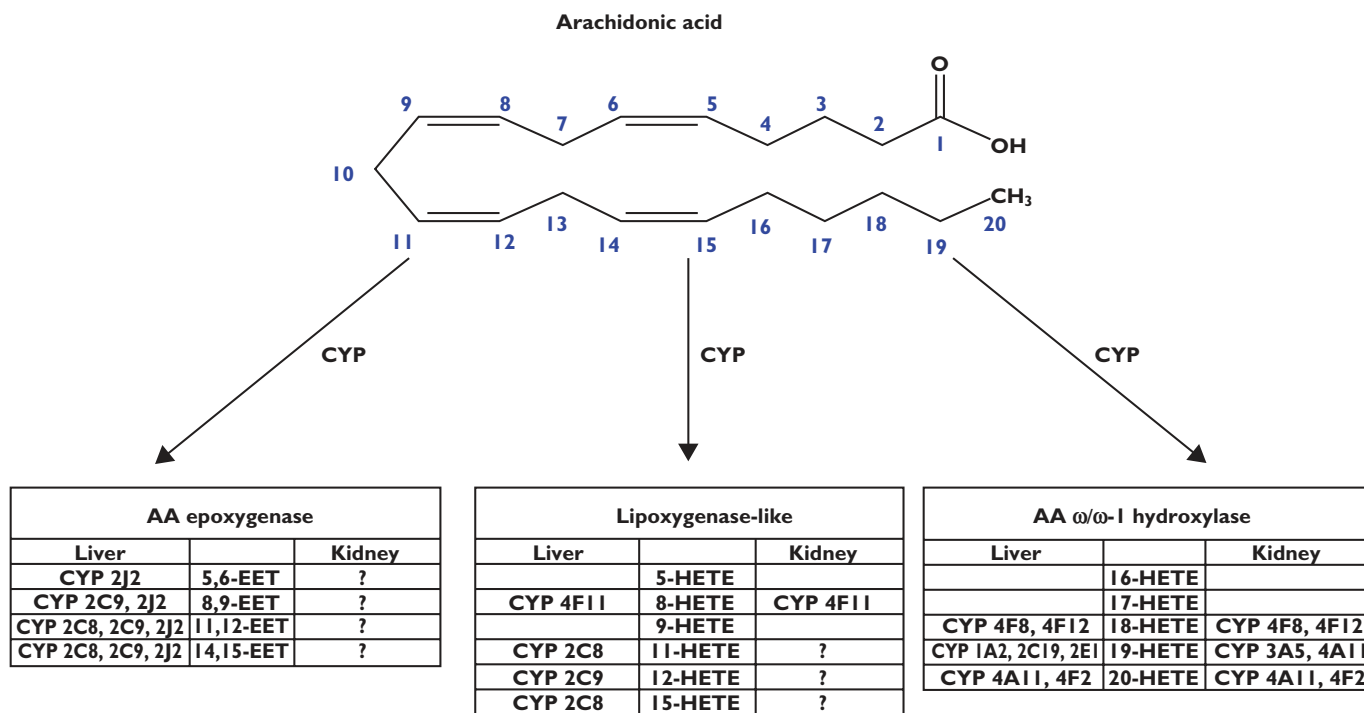

Figure 1

Metabolism of arachidonic acid by hepatic and renal P450 enzymes

substrates have been identified for CYP4A11, CYP4F2 and CYP4F8 and hence renal drug–endobiotic interactions are unlikely. Similarly although xenobiotic substrates have been identified for CYP 2B6, 3A5, 4F11 and 4F12 there are no reports to our knowledge of renal drug–endobiotic interactions.

At present, our knowledge of the human P450s involved in the renal metabolism of both endogenous and exogenous chemicals is incomplete. Thus, we are yet to fully understand the factors controlling renal metabolism via P450 and ultimately the physiological/pathophysiological significance of perturbation of renal P450 mediated metabolism.

Renal UDP-glucuronosyltransferases

Glucuronidation represents a major route of metabolism of both xenobiotics (Table 4) and endobiotics. The glucuronidation reaction involves UDP-glucuronosyltransferase (UGT) catalyzed conjugation of an endogenous/xenobiotic substrate with glucuronic acid, which is derived from the co-factor UDP-glucuronic acid (UDPGA). Given their polar nature, glucuronides are excreted in urine and bile. Like the P450s, UGT comprises an enzyme superfamily. UGTs have been classified in three families (1, 2 and 3) and four subfamilies (1A, 2A, 2B, 3A) based on amino acid sequence identity. Eighteen catalytically active human UGTs that utilize UDPGA as cofactor have been identified, nine each from the UGT1 (1A1, 1A3, 1A4, 1A5, 1A6, 1A7, 1A8, 1A9 and 1A10) and UGT2 (2A1, 2A3, 2B4, 2B7, 2B10, 2B11, 2B15, 2B17 and 2B28) families [68, 69]. Individual UGTs exhibit distinct, but overlapping, substrate selectivity, and differ in terms of regulation of expression and tissue distribution [70]. Activity of the individual UGT enzymes is altered by factors that include age, diet, disease states,

Table 4

Representative major substrates of the main drug metabolizing UDP-glucuronosyltransferase (UGT) enzymes

Enzyme	Representative major substrates
UGT1A1	Bilirubin, estradiol, etoposide, ethynylestradiol, SN-38 (active metabolite of irinotecan), raloxifene
UGT1A3	Telmisartan
UGT1A4	Lamotrigine, olanzapine, trifluoperazine
UGT1A6*	Paracetamol (also UGT 1A1, 1A9, 2B15)
UGT1A9*	Furosemide, mycophenolic acid, phenylbutazone, propofol, raloxifene, retigabine, sulfipyrazone
UGT2B7*	Carbamazepine, chloramphenicol, epirubicin, gemfibrozil, NSAIDs (e.g. fenoprofen, ketoprofen, naproxen), opioids (e.g. codeine, morphine, naloxone), valproic acid, zidovudine
UGT2B15	Lorazepam, oxazepam, temazepam

*Expressed in human kidney.

induction/ inhibition by xenobiotics, ethnicity, genetic polymorphism and hormonal factors [70, 71].

Using immunohistochemistry, expression of UGT1A and UGT2B7 proteins have been reported in the proximal convoluted tubule, loops of Henle, macula densa, epithelial cells of the distal convoluted tubule and medullary collecting ducts of the human nephron [72]. In contrast, no immunoreactivity was demonstrated in either the Bowman's capsule, the glomerulus or in veins, arteries and arterioles in both the cortex and medulla. Expression in the macula densa is consistent with the hypothesis that formation of glucuronide conjugates may modulate the biological activity of endogenous molecules that regulate renal haemodynamics [73]. Using RT-PCR, a subsequent study reported expression of UGT 1A5, 1A6, 1A7, 1A9, 2B4, 2B7 and 2B17 in human kidney. The most abundantly expressed UGT enzyme was UGT1A9 followed by UGT2B7 (~80% of that of UGT1A9) [74]. Importantly UGT1A9 and UGT2B7 catalyze the glucuronidation of numerous drugs (Table 4) [2, 71]. Taking into account the sensitivity and precision of quantitative RT-PCR, the study by Ohno & Nakajin indicates that UGT 1A1, 1A3, 1A4, 1A8, 1A10, 2B10, 2B11 and 2B15 are not expressed in human kidney [74].

Xenobiotic substrates of human renal UGTs

Human kidney catalyzes formation of the glucuronide conjugates of almokalant, carbamazepine, codeine, edaravone, emodin, furosemide, gemfibrozil, morphine, 4-methylumbelliferone, mycophenolic acid, naloxone, 1-naphthol, octyl gallate, paracetamol, retigabine, valproic acid and the non-steroidal anti-inflammatory drugs (NSAIDs) flufenamic acid, flurbiprofen, ibuprofen, ketoprofen, mefenamic acid, S-naproxen and phenylbutazone.

Studies using human kidney microsomes and recombinant UGTs have identified that almokalant glucuronidation is catalyzed by UGT1A9 and UGT2B7, but not by UGT 1A1, 1A3, 1A4, and 1A6 [75]. Similarly, UGT2B7 is involved in the *N*-glucuronidation of carbamazepine whereas UGT 1A1, 1A3, 1A4, 1A6, 1A9 and 2B4 are not [76]. Edaravone, a free radical scavenger is eliminated by glucuronidation (~70%) in humans [77]. A recent study has reported that the intrinsic clearance (CL_{int}) of edaravone via glucuronidation was 5.4-fold higher in human kidney microsomes than human liver microsomes, suggesting a significant role for the kidney in the metabolism of edaravone. Of 12 recombinant UGTs screened, UGT 1A1, 1A6, 1A7, 1A9, 2B7 and 2B17 formed edaravone glucuronide and further kinetic studies established UGT1A9 as the predominant enzyme catalyzing edaravone glucuronidation [78]. As noted previously, UGT1A9 is expressed in human kidney, and during post-marketing surveillance edaravone has been implicated in causing significant renal dysfunction in 8.2% of patients [79].

Glucuronidation of codeine and naloxone has been demonstrated using human kidney and human liver microsomes [80, 81]. Of 13 recombinant UGT enzymes screened only UGT2B4 and UGT2B7, which are both expressed in kidney, catalyzed codeine glucuronidation [82]. The analgesic effect of codeine arises from CYP2D6 catalyzed *O*-demethylation to form morphine [83] and human kidney microsomes metabolizes morphine to both its 3- and 6-glucuronides (M3G and M6G) [81, 84]. Studies with a panel of recombinant UGTs have provided evidence that metabolism of morphine to M3G and M6G is catalyzed predominantly by UGT2B7 [85–88], with lesser contributions from UGT 1A1, 1A3, 1A6, 1A8 and 1A9 [87, 88]. UGT 1A1, 1A3 and 1A8 are not expressed in kidney [73].

Furosemide is a potent diuretic and human kidney cortical and medullary microsomes both efficiently glucuronidate furosemide [89]. The mean CL_{int} was ~1.5-fold higher for cortex compared with medulla, $1.3 \mu\text{l min}^{-1} \text{mg}^{-1}$ and $0.88 \mu\text{l min}^{-1} \text{mg}^{-1}$, respectively. Formation of furosemide glucuronide was catalyzed by UGT 1A1, 1A3, 1A6, 1A7, 1A9, 1A10 and 2B7 only. Comparison of the kinetic parameters for furosemide glucuronidation by UGT1A9 and UGT2B7 and the use of inhibitors of UGT1A9 (phenylbutazone and sulfapyrazole) and UGT2B7 (fluconazole) indicated a predominant role of UGT1A9 in furosemide glucuronidation [89]. These data suggest that the kidney is the main organ responsible for furosemide glucuronidation *in vivo*.

Hydrolysis of mycophenolate mofetil yields the active metabolite, mycophenolic acid (MPA), which is primarily metabolized to MPA-phenyl-glucuronide, the major metabolite, and MPA-acyl-glucuronide. Significant formation of MPA-phenyl-glucuronide by human kidney microsomes has been reported [5, 90]. In a study using human kidney and human liver microsomes CL_{int} values for MPA-phenyl-glucuronide and MPA-acyl-glucuronide formation were similar; 22.6 and $0.12 \mu\text{l mg}^{-1} \text{min}^{-1}$ and 28.7 and $0.38 \mu\text{l mg}^{-1} \text{min}^{-1}$, for kidney and liver, respectively [91]. It has been demonstrated that UGT 1A7, 1A8, 1A9 and 1A10 all catalyze the formation of MPA-phenyl-glucuronide, with the greatest activity observed with UGT1A9. Minimal activity was observed with UGT 1A1, 1A6, 2B7 and 2B4 while no activity was evident using UGT 1A3 and 1A4. In contrast, UGT2B7 is the major enzyme involved in MPA-acyl-glucuronide formation [91].

Paracetamol glucuronidation, which is catalyzed by UGT 1A1, 1A6, 1A9 and 2B15 [92, 93], occurs at a lower rate in human kidney in comparison with human liver microsomes [94]. UGT1A6 has subsequently been shown to be the major enzyme involved in paracetamol glucuronidation [95]. The lower activity in human kidney microsomes is consistent with the lower expression of UGT1A6 in human kidney in comparison with UGT1A9 [74].

As discussed previously propofol glucuronidation by human kidney microsomes is 3–4 times greater than that of human liver microsomes [6]. Since UGT1A9 is the major enzyme responsible for propofol glucuronidation [81,

96, 97], the high activity of human kidney microsomes reflects the high relative abundance of UGT1A9. Similarly UGT1A9, but not any of the other known members of the UGT1A and UGT2B families, is responsible for the C-glucuronidation of phenylbutazone [98]. The same study also reported that phenylbutazone C-glucuronidation activity by human kidney microsomes was 2.9-fold higher than that of human liver microsomes, again reflecting the high relative expression of UGT1A9 in human kidney. The antiepileptic drug retigabine undergoes *N*-glucuronidation forming N2- and N4-glucuronides. Using recombinant UGT1A1, 1A4, 1A6, 1A9, 2B7 and 2B15, Borlak *et al.* demonstrated that UGT1A1 (not expressed in kidney) forms the N4-glucuronide while UGT1A4 (not expressed in kidney) and UGT1A9 (expressed in kidney) formed both the N2- and N4-glucuronides. Activity was not observed with UGT 1A6, 2B7, and 2B15. Not unexpectedly, human kidney microsomes metabolized retigabine to the N2- and N4-glucuronides again, reflecting the presence of UGT1A9 in human kidney [99].

S-Naproxen acyl glucuronide formation by human kidney cortical microsomes exhibits high and low affinity components. Mean CL_{int} values (calculated as V_{max}/K_m), for the high- and low-affinity components of *S*-naproxen acyl glucuronidation by human kidney cortical microsomes were $5.1 \mu\text{l min}^{-1} \text{mg}^{-1}$ and $0.73 \mu\text{l min}^{-1} \text{mg}^{-1}$, respectively [72]. The high affinity component of *S*-naproxen acyl glucuronidation was inhibited by the UGT2B7 selective inhibitor fluconazole [100]. The similarity in K_m values for *S*-naproxen glucuronidation by human kidney cortical microsomes and recombinant UGT2B7 suggests the common involvement of UGT2B7 as the high affinity enzyme in renal tissue [72, 101]. Ketoprofen, another propionic acid NSAID, is glucuronidated by UGT2B7 [102] and human kidney microsomes. Indeed, the CL_{int} for glucuronidation by human kidney microsomes was 2.5-fold higher than that for human liver microsomes [81].

The kinetics of glucuronidation of the NSAIDs flufenamic, mefenamic and niflumic acid using human kidney cortical microsomes, UGT1A9 and UGT2B7 as the enzyme sources have been reported [103]. Notably, the renal CL_{int} of mefenamic acid ($17 \mu\text{l min}^{-1} \text{mg}^{-1}$) was 15-fold higher than that of niflumic acid ($CL_{int} 1.1 \mu\text{l min}^{-1} \text{mg}^{-1}$). UGT1A1 has been identified as the main hepatic enzyme involved in niflumic acid glucuronidation and the apparent lower CL_{int} for niflumic acid in renal tissue reflects the lesser contribution from UGT1A9 and UGT2B7 [103, 104].

Given the predominant role of renal UGT2B7 and UGT1A9 in the glucuronidation of carboxylic acid containing drugs, human kidney microsomes have additionally been shown to glucuronidate gemfibrozil and valproic acid [81, 105], both known UGT2B7 and UGT1A9 substrates [102, 106], and the non-selective UGT substrate 4-methylumbelliferone (4-MU) [4]. The intrinsic clearance for 4-MU glucuronidation by human kidney cortical microsomes ($429 \mu\text{l min}^{-1} \text{mg}^{-1}$) was comparable with that

reported previously for human liver microsomes $414 \mu\text{l min}^{-1} \text{mg}^{-1}$ [107] and again is consistent with a major role of UGT1A9 in 4-MU glucuronidation [4, 108].

Importantly, Tsoutsikos *et al.* reported that unsaturated long chain fatty acids (C16:1-C20:5) were potent inhibitors of 4-MU glucuronidation by HKCM, UGT1A9 and UGT2B7 [4]. In particular, linoleic acid (C18:2) and AA were competitive inhibitors of 4-MU glucuronidation by human kidney cortical microsomes (K_i 6.3 and $0.15 \mu\text{M}$, respectively), while linoleic acid was a competitive inhibitor of UGT1A9 (K_i $4.1 \mu\text{M}$). These were the first data to identify fatty acids as inhibitors of renal xenobiotic glucuronidation [4].

Glucuronidation of fatty acids and eicosanoids

In terms of endogenous substrates the kidney plays an important role in the glucuronidation of 17β -estradiol [109–111] and aldosterone [112, 113]. However, as renal P450 and UGT enzymes are the focus of this review, the following sections detail the role of UGTs in the metabolism of fatty acids and the biosynthetic metabolites of P450 catalyzed reactions.

Fatty acids

In 1994 Pritchard *et al.* described the glucuronidation of medium chain fatty acids (C4-C10) and the unsaturated fatty acids linoleic acid (C18:2), α -linolenic acid (C18:3) and AA by rat UGT2B1 [114]. Subsequently UGT1A3 was shown to glucuronidate decanoic acid (C10:0) and lauric acid (C12:0) [115]. Further studies investigating fatty acid glucuronidation established that UGT2B7 glucuronidates all C14, C16, C18 and C20 saturated and unsaturated fatty acids including AA [116]. In addition, UGT1A9 exhibits the same fatty acid glucuronidation profile as UGT2B7 but has ~ 10 -fold greater activity (Knights, unpublished data). Glucuronidation of AA has also been reported for UGT 1A1, 1A3, 1A4 (minimally), 1A9, 1A10 and UGT2B7 [117]. UGT2B7 additionally glucuronidates linoleic acid diols [118] and the two naturally occurring metabolites of linoleic acid, 13-hydroxyoctadecadienoic acid (13-HODE) and 13-oxooctadecadienoic acid (13-OXO) [118–121].

During acute renal ischaemia fatty acids accumulate intracellularly, and it is known that high concentrations of fatty acids and their metabolites are cytotoxic [122]. Arachidonic acid, linoleic acid and some linoleic acid metabolites (e.g. linoleic acid-diols) are toxic to renal proximal tubular cells, although the exact mechanism of toxicity is unknown [123, 124]. Given the fact that AA is a substrate of UGT1A9 and UGT2B7, it is apparent that glucuronidation plays a key role in both modulating availability of AA (and other fatty acids) for biosynthetic pathways and providing a local intra-renal 'detoxification' pathway limiting the biological reactivity of AA and its bioactive metabolites.

Prostaglandins

The precursor molecule for the synthesis of prostaglandins (PGs) is arachidonic acid, which is liberated from membrane lipids by phospholipase A_2 in response to a variety of stimuli. PGs integral to maintaining renal function are PGI_2 and PGE_2 . PGI_2 acts as a vasodilator of cortical arterioles, maintains glomerular filtration, inhibits sodium reabsorption in the loop of Henle and stimulates renin secretion via an action in the juxtaglomerular apparatus. PGE_2 is produced to a greater extent in the renal medulla in comparison with the cortex but its functional role is similar to PGI_2 [125]. To date, limited studies have investigated the glucuronidation of PGs. UGT 1A1, 1A3, 1A9, 1A10 and 2B7 form PGB_1 and PGE_2 glucuronides with comparable activity observed with UGT1A9 and UGT2B7 for PGB_1 . In contrast, PGE_2 glucuronidation by UGT2B7 exhibits ~ 12 -fold greater activity in comparison with metabolism by UGT1A9 [117].

Leukotrienes

As discussed previously LOX catalyzed metabolism of AA produces six regioisomeric HETEs along with the series-4 leukotrienes (e.g. LTB_4). 12- and 15-HETE are potent glomerular and renal vascular vasoconstrictors and LOX metabolites play a key role in glomerular nephritis [126]. Similar to PGs, the biological activity of the HETEs and LTB_4 is determined by metabolism. LTB_4 is metabolized via both oxidative pathways and by glucuronidation. Glucuronide conjugates of LTB_4 , 20-COOH- LTB_4 and 10,11-dihydro- LTB_4 were identified using primary cultures of human hepatocytes [127]. Additional conjugates of LTB_4 were subsequently identified in human urine. These included the glucuronides of LTB_4 , 17-, 18-, 19-, and 20-hydroxy- LTB_4 , 10-hydroxy-4,6,12-octadecatrienoic acid and 10,11-dihydro- LTB_4 [128]. Using recombinant UGT proteins it was shown that LTB_4 was glucuronidated by UGT 1A1, 1A3, 1A8 and UGT2B7, while the biologically inactive 20-COOH- LTB_4 was glucuronidated solely by UGT1A9 [129].

EETs and HETEs

In terms of the renal P450 metabolism of arachidonic acid, 20-HETE is the principal metabolite and, not surprisingly, 20-HETE is the focus of extensive investigation because of a link with the development of hypertension [26]. 20-HETE is a potent vasoconstrictor that regulates renal function and vascular tone, serves as a second messenger for endothelin-1 and mediates selective renal effects of angiotensin II. In contrast to 20-HETE, the EETs are potent vasodilators. Beyond regulation of the renal circulation, EETs and 20-HETE regulate sodium/potassium ATPase activity and sodium/potassium/chloride transport in the nephron [26]. 20-HETE glucuronide was first identified in human urine [130] and UGT2B7 was subsequently implicated in its formation [119]. The involvement of UGT2B7 was confirmed and it was further established that UGT1A1, UGT1A3, and UGT1A4 all catalyzed 20-HETE

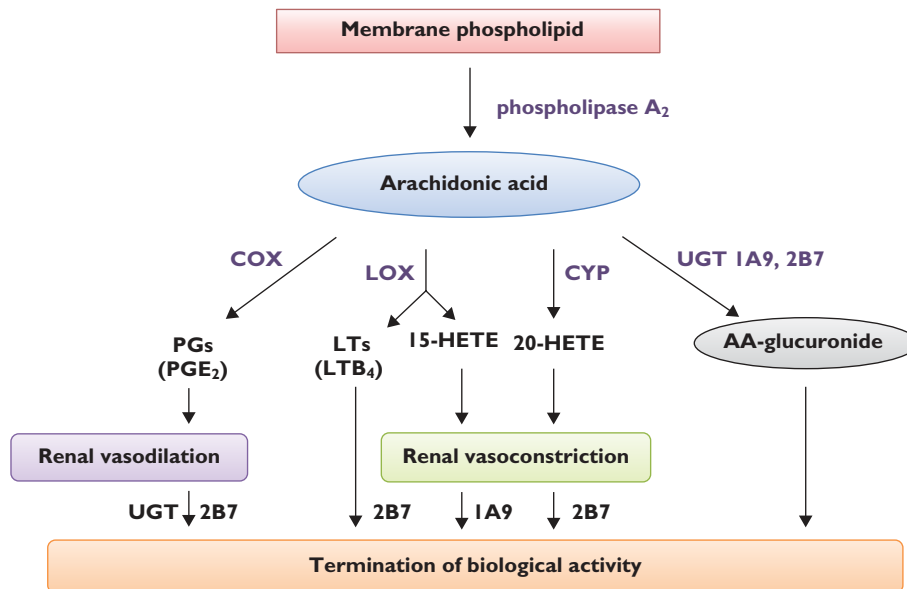

Figure 2

Metabolism of arachidonic acid and eicosanoids by renal UGTs. COX = cyclooxygenase; LOX = lipoxygenase

glucuronidation, but activity was not detected with UGT1A9 [117]. This clearly suggests that UGT2B7 is involved in terminating the biological activity of 20-HETE in human kidney. Further it was demonstrated that 5-HETE was glucuronidated by UGT 1A9, 2B4, 2B7 and 2B10, 12-HETE by UGT 1A1, 1A3, 1A4, 1A9, 2B4, 2B7, 2B10, 2B11 and 2B15 and 15-HETE by UGT 1A1, 1A3, 1A4, 1A8, 1A9, 2B4, 2B7, 2B10 and 2B11 [117]. Tissue specific expression of UGT enzymes is important in this regard. For example, in human kidney UGT 1A9 and 2B7 will play a role in the metabolic elimination of 5-,12- and 15-HETE (Figure 2). In contrast, in human prostate termination of the biological activity of 5-HETE, which promotes cell proliferation [131], will be catalyzed by UGT2B4 and UGT2B15 as prostate lacks UGT1A9 and UGT2B7.

Perspective

UGT1A9 and UGT2B7 are the predominant UGT enzymes expressed in human kidney. In addition to xenobiotics (Table 4), fatty acids, prostaglandins, leukotrienes, EETs, HETEs and the mineralocorticoid aldosterone (along with many other hydroxy-steroids) are also metabolized by UGT1A9 and/or UGT2B7 (Table 5). Thus, glucuronidation can be considered an important ‘local’ clearance pathway as well as an essential catabolic route that modulates the duration of action of biologically active fatty acids and eicosanoids. Much effort has been focussed on inhibition of P450 mediated formation of 20-HETE and EETs by imidazoles (e.g. miconazole, econazole, ketoconazole and

Table 5

Glucuronidation of AA and eicosanoids by recombinant UGT1A9 and UGT2B7

UGT	AA	PGB ₁	PGE ₂	5-HETE	12-HETE	15-HETE	20-HETE	LTB ₄
1A9	++	++	+	+	+	++	ND	ND
2B7	+	+	++	+	+	+	++	+

+ = formation of glucuronide observed; ++ = enzyme with greatest activity; ND = not detected. References [117, 129].

clotrimazole) [132] without regard for the fact that the imidazoles are variously substrates and inhibitors of UGTs, in particular UGT2B7 [82, 100]. Additionally, inhibition of the formation of P450-derived AA metabolites by selective inhibitors does not prevent release of preformed HETEs and EETs bound to lipids in the kidney [133]. If the ‘selective’ P450 inhibitor is also an inhibitor of UGT1A9 and/or UGT2B7 then it can be speculated that, following release from storage sites, the duration of activity of preformed 20-HETE in human kidney will persist as a result of a reduced clearance via glucuronidation. Consequently unravelling the complexities of AA metabolism and the biological activity of AA-derived metabolites in human kidney relies on recognizing not only the impact of inhibitors on the biosynthesis of AA metabolites by renal P450s but also on the clearance via glucuronidation of biologically active eicosanoids. Similarly, it follows that xenobiotic substrates of UGT1A9 and UGT2B7 have the potential

to perturb the integrated biochemical networks that underpin renal function. As an example, NSAIDs inhibit aldosterone 18 β -glucuronidation by human kidney microsomes and UGT2B7, which may subsequently lead to elevated intrarenal concentrations of aldosterone [73]. In turn, the retention of sodium and water would lead to volume expansion and a rise in blood pressure, all features of NSAID toxicity in 'at-risk' individuals [134]. Conversely, as discussed in preceding sections, many NSAIDs that are metabolized by human kidney are also substrates for renal UGT2B7. However, there has been little recognition of the potential role of NSAIDs as inhibitors of 20-HETE glucuronidation. Could this also add further to explaining the variable effects of NSAIDs on blood pressure?

Conclusion

Too often 'metabolism' of arachidonic acid is considered only in terms of the biosynthetic pathways involving P450, COX and LOX without any regard to the pivotal role of catabolism via UGTs. Animal models have signalled the directions to pursue in understanding the pathophysiological consequence of perturbation of AA metabolism, particularly in regard to hypertension. The key question has always been, 'does animal data translate to humans?' It appears that with regard to P450 mediated synthesis of EETs animal data have signalled the wrong organ as the presence of the CYP2C family of enzymes in human kidney is equivocal rather than certain, as commonly claimed in the literature.

Xenobiotic inhibitors of P450s and UGTs abound. Those targeted at inhibiting the formation of EETs in humans should be considered inhibitors of hepatic P450s, whereas those that inhibit formation of HETEs, should be considered as either inhibitors of hepatic or renal P450s depending on the HETE formed. Similarly, with regard to UGT1A9 and UGT2B7, both enzymes are present in human liver and kidney and the effects of UGT inhibitors on the termination of the biological activity of AA derived metabolites will depend on the organ. In the kidney the consequences are somewhere between 'the devil and the deep blue sea,' that is an alteration in the balance between eicosanoids that increase renal blood flow and glomerular filtration and those that increase vascular resistance [135].

Competing Interests

All authors have completed the Unified Competing Interest form (available on request from the corresponding author) and declare: no support from any organization for the submitted work, no financial relationships with any organizations that might have an interest in the submitted work in the previous 3 years and no other relationships or activities that could appear to have influenced the submitted work.

REFERENCES

- Huth EJ, Murray TJ. *Medicine in Quotations: Views of Health and Disease Through the Ages*, 2nd edn. Philadelphia, USA: American College of Physicians, Sheridan Press, 2006; 183.
- Miners JO, Mackenzie PI, Knights KM. The prediction of drug-glucuronidation parameters in humans: UDP-glucuronosyltransferase enzyme-selective substrate and inhibitor probes for reaction phenotyping and in vitro-in vivo extrapolation of drug clearance and drug-drug interaction potential. *Drug Metab Rev* 2010; 42: 196–208.
- Lohr JW, Willsky GR, Acara MA. Renal drug metabolism. *Pharmacol Rev* 1998; 50: 107–41.
- Tsoutsikos P, Miners JO, Stapleton A, Thomas A, Sallustio BC, Knights KM. Evidence that unsaturated fatty acids are potent inhibitors of renal UDP-glucuronosyltransferases (UGT); kinetic studies using human kidney cortical microsomes and recombinant UGT1A9 and UGT2B7. *Biochem Pharmacol* 2004; 67: 191–9.
- Bowalgaha K, Miners JO. The glucuronidation of mycophenolic acid by human liver, kidney and jejunum microsomes. *Br J Clin Pharmacol* 2001; 52: 605–9.
- Raouf AA, van Obbergh LJ, de Goyet J, Verbeeck RK. Extrahepatic glucuronidation of propofol in man: possible contribution of gut wall and kidney. *Eur J Clin Pharmacol* 1996; 50: 91–6.
- McGurk KA, Brierley CH, Burchell B. Drug glucuronidation by human renal UDP-glucuronosyltransferases. *Biochem Pharmacol* 1998; 55: 1005–12.
- Bailey JM, Mora CT, Shafer SL. Pharmacokinetics of propofol in adult patients undergoing coronary revascularization. The Multicenter Study Perioperative Ischemia Research Group. *Anesthesiology* 1996; 84: 1288–97.
- Gray PA, Park GR, Cockshott ID, Douglas EJ, Shuker B, Simons PJ. Propofol metabolism in man during the anhepatic and reperfusion phases of liver transplantation. *Xenobiotica* 1992; 22: 105–14.
- Veroli P, O'Kelly B, Bertrand F, Trouvin JH, Farinotti R, Ecoffey C. Extrahepatic metabolism of propofol in man during the anhepatic phase of orthotopic liver transplantation. *Br J Anaesth* 1992; 68: 183–6.
- Hiraoka H, Yamamoto K, Miyoshi S, Morita T, Nakamura K, Kadoi Y, Kunimoto F, Horiuchi R. Kidneys contribute to the extrahepatic clearance of propofol in humans, but not lungs and brain. *Br J Clin Pharmacol* 2005; 60: 176–82.
- Mazoit JX, Sandouk P, Scherrmann J-M, Roche A. Extrahepatic metabolism of morphine occurs in humans. *Clin Pharmacol Ther* 1990; 48: 613–8.
- Nebert DW, Russell DW. Clinical importance of the cytochromes P450. *Lancet* 2002; 360: 1155–62.
- Nelson DR. Cytochrome P450 nomenclature, 2004. *Cytochrome P450 Protocols* 2006; 320: 1–10.
- Miners JO, Veronese ME, Birkett DJ. *In vitro* approaches for the prediction of human drug metabolism. *Ann Reports Med Chem* 1994; 29: 307–16.

- 16** Miners JO. Evolution of drug metabolism: hitchhiking the technology bandwagon. *Clin Exp Pharmacol Physiol* 2002; 29: 1040–4.
- 17** Williams PA, Cosme J, Ward A, Angove HC, Vinkovic DM, Jhoti H. Crystal structure of human cytochrome P450 2C9 with bound warfarin. *Nature* 2003; 424: 464–8.
- 18** Schoch GA, Yano JK, Webster MR, Griffin KJ, Stout CD, Johnson EF. Structure of human microsomal cytochrome P450 2C8: evidence for a peripheral fatty acid binding site. *J Biol Chem* 2004; 279: 9497–503.
- 19** Webster MR, Yano JK, Schoch GA, Yang C, Griffin KJ, Stout CD, Johnson EF. The structure of human cytochrome P450 2C9 complexed with flurbiprofen at 2.0-Å resolution. *J Biol Chem* 2004; 279: 35630–7.
- 20** Yano JK, Hsu MH, Griffin KJ, Stout CD, Johnson EF. Structures of human microsomal cytochrome P450 2A6 complexed with coumarin and methoxsalen. *Nat Struct Mol Biol* 2005; 12: 822–3.
- 21** Jakobsson SV, Cinti DL. Studies on the cytochrome P-450-containing mono-oxygenase system in human kidney cortex microsomes. *J Pharmacol Exp Ther* 1973; 185: 226–34.
- 22** Morrison AR, Pascoe N. Metabolism of arachidonate through NADPH-dependent oxygenase of renal cortex. *Proc Natl Acad Sci U S A* 1981; 78: 7375–8.
- 23** Karara A, Dishman E, Jacobson H, Falck JR, Capdevila JH. Arachidonic acid epoxygenase; stereochemical analysis of the endogenous epoxyeicosatrienoic acids of human kidney cortex. *FEBS Lett* 1990; 269: 227–30.
- 24** Schwartzman ML, Martasek P, Rios AR, Levere RD, Solangi K, Goodman AJ, Abraham NG. Cytochrome P450-dependent arachidonic acid metabolism in human kidney. *Kidney Int* 1990; 37: 94–9.
- 25** Capdevila JH, Falck JR, Harris RC. Cytochrome P450 and arachidonic acid bioactivation: molecular and functional properties of the arachidonate monooxygenase. *J Lipid Res* 2000; 41: 163–81.
- 26** Roman RJ. P-450 metabolites of arachidonic acid in the control of cardiovascular function. *Physiol Rev* 2002; 82: 131–85.
- 27** Baker JR, Satarug S, Reilly PEB, Edwards RJ, Ariyoshi N, Kamataki T, Moore MR, Williams DJ. Relationships between non-occupational cadmium exposure and expression of nine cytochrome P450 forms in human liver and kidney cortex samples. *Biochem Pharmacol* 2001; 62: 713–21.
- 28** Amet Y, Berthou F, Fournier G, Dreano Y, Bardou L, Cledes J, Menez J-F. Cytochrome P450 4A and 2E1 expression in human kidney microsomes. *Biochem Pharmacol* 1997; 53: 765–71.
- 29** Baker JR, Edwards RJ, Lasker JM, Moore MR, Satarug S. Renal and hepatic accumulation of cadmium and lead in the expression of CYP4F2 and CYP2E1. *Toxicol Lett* 2005; 159: 182–91.
- 30** Lasker JM, Chen WB, Wolf I, Bloswick BP, Wilson PD, Powell PK. Formation of 20-hydroxyeicosatetraenoic acid, a vasoactive and natriuretic eicosanoid, in human kidney. *J Biol Chem* 2000; 275: 4118–26.
- 31** Zeldin DC, DuBois RN, Falck JR, Capdevila JH. Molecular cloning, expression and characterization of an endogenous human cytochrome P450 arachidonic acid epoxygenase isoform. *Arch Biochem Biophys* 1995; 322: 76–86.
- 32** Zeldin DC, Moomaw CR, Jesse N, Tomer KB, Beetham J, Hammock BD, Wu S. Biochemical characterization of the human liver cytochrome P450 arachidonic acid epoxygenase pathway. *Arch Biochem Biophys* 1996; 330: 87–96.
- 33** Enayetallah AE, French RA, Thibodeau MS, Grant DF. Distribution of soluble epoxide hydrolase and of cytochrome P450 2C8, 2C9, and 2J2 in human tissue. *J Histochem Cytochem* 2004; 52: 447–54.
- 34** Dai D, Zeldin DC, Blaisdell JA, Chanas B, Coulter SJ, Ghanayem BI, Goldstein JA. Polymorphisms in human CYP2C8 decrease metabolism of the anticancer drug paclitaxel and arachidonic acid. *Pharmacogenetics* 2001; 11: 597–607.
- 35** Haehner BD, Gorski JC, Vandenbranden M, Wrighton SA, Janardan SK, Watkins PB, Hall SD. Bimodal distribution of renal cytochrome P450 3A activity in humans. *Mol Pharmacol* 1996; 50: 52–9.
- 36** Schuetz EG, Schuetz JD, Grogan WM, Naray-Fejes-Toth A, Fejes-Toth G, Raucy J, Guzelian P, Gionela K, Watlington CO. Expression of cytochrome P450 3A in amphibian, rat, and human kidney. *Arch Biochem Biophys* 1992; 294: 206–14.
- 37** Aleksa K, Matsell D, Krausz K, Gelboin H, Ito S, Koren G. Cytochrome P450 3A and 2B6 in the developing kidney: implications for ifosfamide nephrotoxicity. *Pediatr Nephrol* 2005; 20: 872–85.
- 38** Wu S, Moomaw CR, Tomer KB, Falck JR, Zeldin DC. Molecular cloning and expression of CYP2J2, a human cytochrome P450 arachidonic acid epoxygenase highly expressed in heart. *J Biol Chem* 1996; 271: 3460–68.
- 39** Bylund J, Kunz T, Valmsen K, Oliw EH. Cytochrome P450 with bisallylic hydroxylation activity on arachidonic and linoleic acids studied with human recombinant enzymes and with human and rat liver microsomes. *J Pharmacol Exp Ther* 1998; 284: 51–60.
- 40** Daikh B, Lasker JM, Raucy JL, Koop DR. Regio- and stereoselective epoxidation of arachidonic acid by human cytochromes P450 2C8 and 2C9. *J Pharmacol Exp Ther* 1994; 271: 1427–33.
- 41** Rifkind AB, Lee C, Chang TKH, Waxman DJ. Arachidonic acid metabolism by human cytochrome P450s 2C8, 2C9, 2E1, and 1A2: regioselective oxygenation and evidence for a role for CYP2C enzymes in arachidonic acid epoxygenation in human liver microsomes. *Arch Biochem Biophys* 1995; 321: 380–9.
- 42** Capdevila JH, Holla VR, Falck JR. Cytochrome P450 and the metabolism and bioactivation of arachidonic acid and eicosanoids. In: *Cytochrome P450: Structure, Mechanism, and Biochemistry*, 3e edn. ed. Ortiz de Montellano PR. New York: Kluwer Academic, Plenum Publishers, 2005; 531–51.

- 43** Ohe T, Hirobe M, Mashino T. Novel metabolic pathway of estrone and 17 β -estradiol catalyzed by cytochrome P-450. *Drug Metab Dispos* 2000; 28: 110–2.
- 44** Marill J, Cresteil T, Lanotte M, Chabot GG. Identification of human cytochrome P450s involved in the formation of all-trans-retinoic acid principal metabolites. *Mol Pharmacol* 2000; 58: 1341–8.
- 45** Wang H, Tompkins LM. CYP2B6: new insights into a historically overlooked cytochrome P450 isozyme. *Curr Drug Metab* 2008; 9: 598–610.
- 46** Hodgson E, Rose RL. The importance of cytochrome P450 2B6 in the human metabolism of environmental chemicals. *Pharmacol Ther* 2007; 113: 420–8.
- 47** Dai Y, Iwanaga K, Lin YS, Hebert MF, Davis CL, Huang W, Kharasch ED, Thummel KE. In vitro metabolism of cyclosporine A by human kidney CYP3A5. *Biochem Pharmacol* 2004; 68: 1889–902.
- 48** McCune JS, Risler LJ, Phillips BR, Thummel KE, Blough D, Shen DD. Contribution of CYP3A5 to hepatic and renal ifosfamide N-dechloroethylation. *Drug Metab Dispos* 2005; 33: 1074–81.
- 49** Powell PK, Wolf I, Jin R, Lasker JM. Metabolism of arachidonic acid to 20-hydroxy-5,8,11,14-eicosatetraenoic acid by P450 enzymes in human liver: involvement of CYP4F2 and CYP4A11. *J Pharmacol Exp Ther* 1998; 285: 1327–36.
- 50** Snider NT, Kornilov AM, Kent UM, Hollenberg PF. Anandamide metabolism by human liver and kidney microsomal cytochrome P450 enzymes to form hydroxyeicosatetraenoic and epoxyeicosatrienoic acid ethanolamides. *J Pharmacol Exp Ther* 2007; 321: 590–7.
- 51** Jin R, Koop DR, Raucy JL, Lasker JM. Role of human CYP4F2 in hepatic catabolism of the proinflammatory agent leukotriene B₄. *Arch Biochem Biophys* 1998; 359: 89–98.
- 52** Bylund J, Hidestrand M, Ingelman-Sundberg M, Oliw EH. Identification of CYP4F8 in human seminal vesicles as a prominent 19-hydroxylase of prostaglandin endoperoxides. *J Biol Chem* 2000; 275: 21844–9.
- 53** Kalsotra A, Turman CM, Kikuta Y, Strobel HW. Expression and characterization of human cytochrome P450 4F11: putative role in the metabolism of therapeutic drugs and eicosanoids. *Toxicol App Pharmacol* 2004; 199: 295–304.
- 54** Bylund J, Bylund M, Oliw EH. cDNA cloning and expression of CYP4F12, a novel human cytochrome P450. *Biochem Biophys Res Comm* 2001; 280: 892–97.
- 55** Rendic S, Nolteernsting E, Schanzer W. Metabolism of anabolic steroids by recombinant human cytochrome P450 enzymes. *J Chromatog* 1999; 735: 73–83.
- 56** Gervot L, Rochat B, Gautier JC, Bohnenstengel F, Kroemer H, de Berardinis V, Martin H, Beaune P, de Waziers I. Human CYP2B6 expression, inducibility and catalytic activities. *Pharmacogenetics* 1999; 9: 295–306.
- 57** Joy MS, Hogan SL, Thompson BD, Finn WF, Nickeleit V. Cytochrome P450 3A5 expression in the kidneys of patients with calcineurin inhibitor nephrotoxicity. *Nephrol Dial Transplant* 2007; 22: 1963–8.
- 58** Kuehl P, Zhang J, Lin Y, Lamba J, Assem M, Schuetz J, Watkins PB, Daly A, Wrighton SA, Hall SD, Maurel P, Relling M, Brimer C, Yasuda K, Venkataramanan R, Strom S, Thummel K, Boguski MS, Schuetz E. Sequence diversity in CYP3A promoters and characterization of the genetic basis of polymorphic CYP3A5 expression. *Nat Genet* 2001; 27: 383–91.
- 59** Givens RC, Lin YS, Dowling ALS, Thummel KE, Lamba JK, Schuetz EG, Stewart PW, Watkins PB. CYP3A5 genotype predicts renal CYP3A activity and blood pressure in healthy adults. *J Appl Physiol* 2003; 95: 1297–300.
- 60** Zheng S, Tasnif Y, Hebert MF, Davis CL, Shitara Y, Calamia JC, Lin YS, Shen DD, Thummel KE. Measurement and compartmental modelling of the effect of CYP3A5 gene variation on systemic and intrarenal tacrolimus disposition. *Clin Pharmacol Ther* 2012; 92: 737–45.
- 61** Imaoka S, Ogawa H, Kimura S, Gonzalez FJ. Complete cDNA sequence and cDNA-directed expression of CYP4A11, a fatty acid ω -hydroxylase expressed in human kidney. *DNA Cell Biol* 1993; 12: 893–9.
- 62** Stark K, Dostalek M, Guengerich FP. Expression and purification of orphan cytochrome P450 4X1 and oxidation of anandamide. *FEBS J* 2008; 275: 3706–17.
- 63** Stark K, Torma H, Cristea M, Oliw EH. Expression of CYP4F8 (prostaglandin H 19-hydroxylase) in human epithelia and prominent induction in epidermis of psoriatic lesions. *Archiv Biochem Biophys* 2003; 409: 188–96.
- 64** Cui X, Nelson DR, Strobel HW. A novel human cytochrome P450 4F isoform (CYP4F11): cDNA cloning, expression, and genomic structural characterization. *Genomics* 2000; 68: 161–6.
- 65** Stark K, Schauer L, Sahlen GE, Ronquist G, Oliw EH. Expression of CYP4F12 in gastrointestinal and urogenital epithelia. *Basic Clin Pharmacol Toxicol* 2004; 94: 177–83.
- 66** Hashizume T, Imaoka S, Mise M, Terauchi Y, Fujii T, Miyazaki H, Kamataki T, Funae Y. Involvement of CYP2J2 and CYP4F12 in the metabolism of ebastine in human intestinal microsomes. *J Pharmacol Exp Ther* 2002; 300: 298–304.
- 67** Capdevila JH, Falck JR, Imig JD. Roles of cytochrome P450 arachidonic acid monooxygenases in the control of systemic blood pressure and experimental hypertension. *Kid Int* 2007; 72: 683–9.
- 68** Mackenzie PI, Bock KW, Burchell B, Guillemette C, Ikushiro S, Iyanagi T, Miners JO, Owens IS, Nebert DW. Nomenclature update for the mammalian UDP glycosyltransferase (UGT) gene superfamily. *Pharmacogenet Genomics* 2005; 15: 677–85.
- 69** Court MH, Hazarika S, Krishnaswamy S, Finel M, Williams JA. Novel polymorphic human UDP-glucuronosyltransferase 2A3: cloning, functional characterization of enzyme variants, comparative tissue expression, and gene induction. *Mol Pharmacol* 2008; 74: 744–54.
- 70** Miners JO, Smith PA, Sorich MJ, McKinnon RA, Mackenzie PI. Predicting human drug glucuronidation parameters:

- application of *in vitro* and *in silico* modeling approaches. *Annu Rev Pharmacol Toxicol* 2004; 44: 1–25.
- 71** Miners JO, Mackenzie PI. Drug glucuronidation in humans. *Pharmacol Ther* 1991; 51: 347–69.
- 72** Gaganis P, Miners JO, Brennan JS, Thomas A, Knights KM. Human renal cortical and medullary UDP-glucuronosyltransferases (UGTs): immunohistochemical localization of UGT2B7 and UGT1A enzymes and kinetic characterization of *S*-naproxen glucuronidation. *J Pharmacol Exp Ther* 2007; 323: 422–30.
- 73** Knights KM, Tsoutsikos P, Miners JO. Novel mechanisms of nonsteroidal anti-inflammatory drug-induced renal toxicity. *Expert Opin Drug Metab Toxicol* 2005; 1: 399–408.
- 74** Ohno S, Nakajin S. Determination of mRNA expression of human UDP-glucuronosyltransferases and application for localization in various human tissues by real-time reverse transcriptase-polymerase chain reaction. *Drug Metab Disp* 2009; 37: 32–40.
- 75** Gaiser BK, Lockley DJ, Staines AG, Baarnhielm C, Burchell B. Alkylant glucuronidation in human liver and kidney microsomes: evidence for the involvement of UGT1A9 and 2B7. *Xenobiotica* 2003; 33: 1073–83.
- 76** Staines AG, Coughtrie MWH, Burchell B. N-glucuronidation of carbamazepine in human tissues is mediated by UGT2B7. *J Pharmacol Exp Ther* 2004; 311: 1131–7.
- 77** Komatsu T, Nakai H, Takamatsu Y, Morinaka Y, Watanabe K, Shinoda M, Iida S. Pharmacokinetic studies of 3-methyl-1-phenyl-2-pyrazolin-5-one (MCI-186): metabolism in rats, dogs and human. *Drug Metab Pharmacokinet* 1996; 11: 451–62.
- 78** Ma L, Sun J, Peng Y, Zhang R, Shao F, Hu X, Zhu J, Wang X, Cheng X, Zhu Y, Wan P, Feng D, Wu H, Wang G. Glucuronidation of edaravone by human liver and kidney microsomes: biphasic kinetics and identification of UGT1A9 as the major UDP-glucuronosyltransferase isoform. *Drug Metab Disp* 2012; 40: 734–41.
- 79** Hishida A. Clinical analysis of 207 patients who developed renal disorders during or after treatment with edaravone reported during post-marketing surveillance. *Clin Exp Nephrol* 2007; 11: 292–6.
- 80** Yue QY, von Bahr C, Odar-Cederlof I, Sawe J. Glucuronidation of codeine and morphine in human liver and kidney microsomes: effect of inhibitors. *Pharmacol Toxicol* 1990; 66: 221–6.
- 81** Soars MG, Burchell B, Riley RJ. *In vitro* analysis of human drug glucuronidation and prediction of *in vivo* metabolic clearance. *J Pharmacol Exp Ther* 2002; 301: 382–90.
- 82** Raungrut P, Uchaipichat V, Elliot DJ, Janchawee B, Somogyi AA, Miners JO. *In vitro-in vivo* extrapolation predicts drug-drug interactions arising from inhibition of codeine glucuronidation by dextropropoxyphene, fluconazole, ketoconazole, and methadone in humans. *J Pharmacol Exp Ther* 2010; 334: 609–18.
- 83** Somogyi AA, Barratt DT, Collier JK. Pharmacogenetics of opioids. *Clin Pharmacol Ther* 2007; 81: 429–44.
- 84** Yue QY, Odar-Cederlof I, Svensson JO, Sawe J. Glucuronidation of morphine in human kidney microsomes. *Pharmacol Toxicol* 1988; 63: 337–41.
- 85** Coffman BL, Rios GR, King CD, Tephly TR. Human UGT2B7 catalyzes morphine glucuronidation. *Drug Metab Disp* 1997; 25: 1–4.
- 86** Court MH, Krishnaswamy S, Hao Q, Duan SX, Patten CJ, Von Moltke LL, Greenblatt DJ. Evaluation of 3'-azido-3'-deoxythymidine, morphine, and codeine as probe substrates for UDP-glucuronosyltransferase 2B7 (UGT2B7) in human liver microsomes: specificity and influence of the UGT2B7*2 polymorphism. *Drug Metab Disp* 2003; 31: 1125–33.
- 87** Stone AN, Mackenzie PI, Galetin A, Houston JB, Miners JO. Isoform selectivity and kinetics of morphine 3- and 6-glucuronidation by human UDP-glucuronosyltransferases: evidence for atypical glucuronidation kinetics by UGT2B7. *Drug Metab Disp* 2003; 31: 1086–9.
- 88** Ohno S, Kawana K, Nakajin S. Contribution of UDP-glucuronosyltransferase 1A1 and 1A8 to morphine-6-glucuronidation and its kinetic properties. *Drug Metab Disp* 2008; 36: 688–94.
- 89** Kerdpin O, Knights KM, Elliot DJ, Miners JO. *In vitro* characterisation of human renal and hepatic frusemide glucuronidation and identification of the UDP-glucuronosyltransferase enzymes involved in this pathway. *Biochem Pharmacol* 2008; 76: 249–57.
- 90** Vietri M, Pietrabissa A, Mosca F, Pacifici GM. Mycophenolic acid glucuronidation and its inhibition by non-steroidal anti-inflammatory drugs in human liver and kidney. *Eur J Clin Pharmacol* 2000; 56: 659–64.
- 91** Picard N, Ratanasavanh D, Premaud A, Le Meur Y, Marquet P. Identification of the UDP-glucuronosyltransferase isoforms involved in mycophenolic acid phase II metabolism. *Drug Metab Dispos* 2005; 33: 139–46.
- 92** Court MH, Duan SX, von Moltke LL, Greenblatt DJ, Patten CJ, Miners JO, Mackenzie PI. Interindividual variability in acetaminophen glucuronidation by human liver microsomes: identification of relevant acetaminophen UDP-glucuronosyltransferase isoforms. *J Pharmacol Exp Ther* 2001; 299: 998–1006.
- 93** Mutlib AE, Goosen TC, Bauman JN, Williams JA, Kulkarni S, Kostrubsky S. Kinetics of acetaminophen glucuronidation by UDP-glucuronosyltransferases 1A1, 1A6, 1A9, and 2B15. Potential implications in acetaminophen induced hepatotoxicity. *Chem Res Toxicol* 2006; 19: 701–9.
- 94** Fisher MB, Vanden Branden M, Findlay K, Burchell B, Thummel KE, Hall SD, Wrighton SA. Tissue distribution and interindividual variation in human UDP-glucuronosyltransferase activity: relationship between UGT1A1 promoter genotype and variability in a liver bank. *Pharmacogenetics* 2000; 10: 727–39.
- 95** Miners JO, Bowalgaha K, Elliot DJ, Baranczewski P, Knights KM. Characterization of niflumic acid as a selective inhibitor of human liver microsomal UDP-glucuronosyltransferase 1A9: application to the reaction phenotyping of acetaminophen glucuronidation. *Drug Metab Disp* 2011; 39: 644–52.

- 96** Miners JO, Knights KM, Houston JB, Mackenzie PI. In vitro-in vivo correlation for drugs and other compounds eliminated by glucuronidation in humans: pitfalls and promises. *Biochem Pharmacol* 2006; 71: 1531–9.
- 97** Rowland A, Knights KM, Mackenzie PI, Miners JO. The 'albumin effect' and drug glucuronidation: bovine serum albumin and fatty acid-free human serum albumin enhance the glucuronidation of UDP-glucuronosyltransferase (UGT) 1A9 substrates but not UGT1A1 and UGT1A6 activities. *Drug Metab Dispos* 2008; 36: 1056–62.
- 98** Nishiyama T, Kobori T, Arai K, Ogura K, Ohnuma T, Ishii K, Hayashi K, Hiratsuka A. Identification of human UDP-glucuronosyltransferase isoform(s) responsible for the C-glucuronidation of phenylbutazone. *Arch Biochem Biophys* 2006; 454: 72–9.
- 99** Borlak J, Gasparic A, Locher M, Schupke H, Hermann R. N-Glucuronidation of the antiepileptic drug retigabine: results from studies with human volunteers, heterologously expressed human UGTs, human liver, kidney, and liver microsomal membranes of Crigler-Najjar type II. *Metab Clin Exper* 2006; 55: 711–21.
- 100** Uchaipichat V, Winner LK, Mackenzie PI, Elliot DJ, Williams JA, Miners JO. Quantitative prediction of in vivo inhibitory interactions involving glucuronidated drugs from *in vitro* data: the effect of fluconazole on zidovudine glucuronidation. *Br J Clin Pharmacol* 2006; 61: 427–39.
- 101** Bowalgaha K, Elliot DJ, Mackenzie PI, Knights KM, Swedmark S, Miners JO. S-naproxen and desmethylnaproxen glucuronidation by human liver microsomes and recombinant human UDP-glucuronosyltransferase (UGT): role of UGT2B7 in the elimination of naproxen. *Br J Clin Pharmacol* 2005; 60: 423–33.
- 102** Jin CJ, Miners JO, Lillywhite KJ, Mackenzie PI. Complementary deoxyribonucleic cloning and expression of a human liver uridine diphosphate glucuronosyltransferase glucuronidating carboxylic acid containing drugs. *J Pharmacol Exp Ther* 1993; 264: 475–9.
- 103** Gaganis P, Miners JO, Knights KM. Glucuronidation of fenamates: kinetic studies using human kidney cortical microsomes and recombinant UDP-glucuronosyltransferase (UGT) 1A9 and 2B7. *Biochem Pharmacol* 2007; 73: 1683–91.
- 104** Mano Y, Usui T, Kamimura H. Identification of human UDP-glucuronosyltransferase responsible for the glucuronidation of niflumic acid in human liver. *Pharmacol Res* 2006; 23: 1502–8.
- 105** Soars MG, Riley RJ, Findlay KAB, Coffey MJ, Burchell B. Evidence for significant differences in microsomal drug glucuronidation by canine and human liver and kidney. *Drug Metab Disp* 2001; 29: 121–6.
- 106** Sakaguchi K, Green M, Stock N, Reger TS, Zunic J, King C. Glucuronidation of carboxylic acid containing compounds by UDP-glucuronosyltransferase isoforms. *Arch Biochem Biophys* 2004; 424: 219–25.
- 107** Miners JO, Lillywhite KJ, Matthews AP, Jones ME, Birkett DJ. Kinetic and inhibitor studies of 4-methylumbelliferone and 1-naphthol glucuronidation in human liver microsomes. *Biochem Pharmacol* 1988; 37: 665–71.
- 108** Uchaipichat V, Mackenzie PI, Guo X-H, Gardner-Stephen D, Galetin A, Houston JB, Miners JO. Human UDP-glucuronosyltransferases: isoform selectivity and kinetics of 4-methylumbelliferone and 1-naphthol glucuronidation, effects of organic solvents, and inhibition by diclofenac and probenecid. *Drug Metab Disp* 2004; 34: 413–23.
- 109** Hobkirk R, Green RN, Nilsen M, Jennings BA. Formation of estrogen glucosiduronates by human kidney homogenates. *Can J Biochem* 1973; 52: 9–14.
- 110** Mellor JD, Hobkirk R. In vitro synthesis of estrogen glucuronides and sulfates by human renal tissue. *Can J Biochem* 1975; 53: 779–83.
- 111** Itaaho K, Mackenzie PI, Ikushiro SI, Miners JO, Finel M. The configuration of the 17-hydroxy group variably influences the glucuronidation of β -estradiol and epiestradiol by human UDP-glucuronosyltransferases. *Drug Metab Dispos* 2008; 36: 2307–15.
- 112** Bledsoe T, Liddle GW, Riondel A, Island DP, Bloomfield D, Sinclair-Smith B. Comparative fates of intravenously and orally administered aldosterone: evidence for extrahepatic formation of acid-hydrolyzable conjugate in man. *J Clin Invest* 1966; 45: 264–9.
- 113** Knights KM, Winner LK, Elliot DJ, Bowalgaha K, Miners JO. Aldosterone glucuronidation by human liver and kidney microsomes and recombinant UDP-glucuronosyltransferases: inhibition by NSAIDs. *Br J Clin Pharmacol* 2009; 68: 402–12.
- 114** Pritchard M, Fournel-Gigleux S, Siest G, Mackenzie P, Magdalou J. A recombinant phenobarbital-inducible rat liver UDP-glucuronosyltransferase (UDP-glucuronosyltransferase 2B1) stably expressed in V79 cells catalyses the glucuronidation of morphine, phenols and carboxylic acids. *Mol Pharmacol* 1994; 45: 42–50.
- 115** Green MD, King CD, Mojarrabi B, Mackenzie PI, Tephly TR. Glucuronidation of amines and other xenobiotics catalysed by expressed human UDP-glucuronosyltransferase 1A3. *Drug Metab Disp* 1998; 26: 507–12.
- 116** Rowland A, Gaganis P, Elliot DJ, Mackenzie PI, Knights KM, Miners JO. Binding of inhibitory fatty acids is responsible for the enhancement of UDP-glucuronosyltransferase 2B7 activity by albumin: implications for *in vitro-in vivo* extrapolation. *J Pharmacol Ther* 2007; 321: 137–47.
- 117** Little JM, Kurkela M, Sonka J, Jantti S, Ketola R, Bratton S, Finel M, Radomska-Pandya A. Glucuronidation of oxidised fatty acids and prostaglandins B₁ and E₂ by human hepatic and recombinant UDP-glucuronosyltransferases (UGT). *J Lipid Res* 2004; 45: 1694–703.
- 118** Jude AR, Little JM, Czernik PJ, Tephly TR, Grant DF, Radomska-Pandya A. Glucuronidation of linoleic acid diols by human microsomal and recombinant UDP-glucuronosyltransferases: identification of UGT2B7 as the major isoform involved. *Arch Biochem Biophys* 2001; 389: 176–86.

- 119** Sonka J, Little J, Samokyszyn V, Radomska-Pandya A. Glucuronidation of arachidonic acid, 20-hydroxy-eicosatetraenoic acid and prostaglandin E2 by human hepatic and intestinal UDP-glucuronosyltransferases and recombinant UGT2B7. *Drug Metab Rev* 2002; 34 (Suppl. 1): 194.
- 120** Jude AR, Little JM, Freeman JP, Evans JE, Radomska-Pandya A, Grant DF. Linoleic acid diols are novel substrates for human UDP-glucuronosyltransferases. *Arch Biochem Biophys* 2000; 380: 294–302.
- 121** Jude AR, Little JM, Bull AW, Podgorski I, Radomska-Pandya A. 13-Hydroxy- and 13-oxooctadecadienoic acids: novel substrates for human UDP-glucuronosyltransferases. *Drug Metab Dispos* 2001; 29: 652–5.
- 122** Ruidera E, Irazu CE, Rajagopalan PR, Orak JK, Fitts CT, Singh I. Fatty acid metabolism in renal ischemia. *Lipids* 1988; 23: 882–84.
- 123** Moran JH, Weise R, Schnellmann RG, Freeman JP, Grant DF. Cytotoxicity of linoleic acid diols to renal proximal tubular cells. *Toxicol Appl Pharmacol* 1997; 146: 53–9.
- 124** Moran JH, Nowak G, Grant DF. Analysis of the toxic effects of linoleic acid, 12,13-cis-epoxyoctadecenoic acid, and 12,13-dihydroxyoctadecenoic acid in rabbit renal cortical mitochondria. *Toxicol Appl Pharmacol* 2001; 172: 150–61.
- 125** Simmons DL, Botting RM, Hla T. Cyclooxygenase isozymes: the biology of prostaglandin synthesis and inhibition. *Pharmacol Rev* 2004; 56: 387–437.
- 126** Imig JD. Eicosanoid regulation of renal vasculature. *Am J Physiol* 2000; 279: F965–81.
- 127** Wheelan P, Hankin JA, Bilir B, Guenette D, Murphy RC. Metabolic transformations of leukotriene B₄ in primary cultures of human hepatocytes. *J Pharmacol Exp Ther* 1999; 288: 326–34.
- 128** Zemski Berry KA, Borgea P, Gosselin J, Flamand L, Murphy RC. Urinary metabolites of leukotriene B₄ in the human subject. *J Biol Chem* 2003; 278: 24449–60.
- 129** Turgeon D, Chouinard S, Belanger P, Picard S, Labbe JF, Borgeat P, Belanger A. Glucuronidation of arachidonic and linoleic acid metabolites by human UDP-glucuronosyltransferases. *J Lipid Res* 2003; 44: 1182–91.
- 130** Prakash C, Zhang JY, Falck JR, Chauhan K, Blair IA. 20-Hydroxyeicosatetraenoic acid is excreted as a glucuronide conjugate in human urine. *Biochem Biophys Res Comm* 1992; 185: 728–33.
- 131** Nie D, Che M, Grignon D, Tang K, Honn KV. Role of eicosanoids in prostate cancer progression. *Cancer Metastasis* 2001; 20: 195–206.
- 132** Capdevila J, Gil L, Orellana M, Marnett LJ, Mason JI, Yadagiri P, Flack JR. Inhibitors of cytochrome P-450-dependent arachidonic acid metabolism. *Arch Biochem Biophys* 1988; 261: 257–63.
- 133** Carroll MA, Balazy M, Huang DD, Rybalova S, Flack JR, McGiff JC. Cytochrome P450-derived renal HETEs: storage and release. *Kidney Int* 1997; 51: 1696–702.
- 134** Gembro G, Perazella MA. Adverse renal effects of anti-inflammatory agents: evaluation of selective and nonselective cyclooxygenase inhibitors. *J Int Med* 2003; 253: 643–52.
- 135** Imig JD. Eicosanoids and renal vascular function in diseases. *Clin Sci* 2006; 111: 21–34.