

---

# Renewable and Efficient Electric Power Systems

---

**Gilbert M. Masters**

*Stanford University*



**WILEY-  
INTERSCIENCE**

A JOHN WILEY & SONS, INC., PUBLICATION



# Renewable and Efficient Electric Power Systems



---

# Renewable and Efficient Electric Power Systems

---

**Gilbert M. Masters**

*Stanford University*



**WILEY-  
INTERSCIENCE**

A JOHN WILEY & SONS, INC., PUBLICATION

Copyright © 2004 by John Wiley & Sons, Inc., Hoboken, New Jersey. All rights reserved.

Published by John Wiley & Sons, Inc., Hoboken, New Jersey.  
Published simultaneously in Canada.

No part of this publication may be reproduced, stored in a retrieval system, or transmitted in any form or by any means, electronic, mechanical, photocopying, recording, scanning, or otherwise, except as permitted under Section 107 or 108 of the 1976 United States Copyright Act, without either the prior written permission of the Publisher, or authorization through payment of the appropriate per-copy fee to the Copyright Clearance Center, Inc., 222 Rosewood Drive, Danvers, MA 01923, 978-750-8400, fax 978-750-4470, or on the web at [www.copyright.com](http://www.copyright.com). Requests to the Publisher for permission should be addressed to the Permissions Department, John Wiley & Sons, Inc., 111 River Street, Hoboken, NJ 07030, (201) 748-6011, fax (201) 748-6008, e-mail: [permreq@wiley.com](mailto:permreq@wiley.com).

**Limit of Liability/Disclaimer of Warranty:** While the publisher and author have used their best efforts in preparing this book, they make no representations or warranties with respect to the accuracy or completeness of the contents of this book and specifically disclaim any implied warranties of merchantability or fitness for a particular purpose. No warranty may be created or extended by sales representatives or written sales materials. The advice and strategies contained herein may not be suitable for your situation. You should consult with a professional where appropriate. Neither the publisher nor author shall be liable for any loss of profit or any other commercial damages, including but not limited to special, incidental, consequential, or other damages.

For general information on our other products and services please contact our Customer Care Department within the U.S. at 877-762-2974, outside the U.S. at 317-572-3993 or fax 317-572-4002.

Wiley also publishes its books in a variety of electronic formats. Some content that appears in print, however, may not be available in electronic format.

***Library of Congress Cataloging-in-Publication Data***

Masters, Gilbert M.

Renewable and efficient electric power systems / Gilbert M. Masters.

p. cm.

Includes bibliographical references and index.

ISBN 0-471-28060-7 (cloth)

1. Electric power systems—Energy conservation. 2. Electric power systems—Electric losses. I. Title

TK1005.M33 2004

621.31—dc22

2003062035

Printed in the United States of America.

10 9 8 7 6 5 4 3 2 1

To the memory of my father,  
Gilbert S. Masters  
1910–2004





---

# CONTENTS

---

<b>Preface</b>	<b>xvii</b>
<b>1 Basic Electric and Magnetic Circuits</b>	<b>1</b>
1.1 Introduction to Electric Circuits	1
1.2 Definitions of Key Electrical Quantities	2
1.2.1 Charge	2
1.2.2 Current	3
1.2.3 Kirchhoff's Current Law	3
1.2.4 Voltage	5
1.2.5 Kirchhoff's Voltage Law	7
1.2.6 Power	7
1.2.7 Energy	8
1.2.8 Summary of Principal Electrical Quantities	8
1.3 Idealized Voltage and Current Sources	9
1.3.1 Ideal Voltage Source	9
1.3.2 Ideal Current Source	10
1.4 Electrical Resistance	10
1.4.1 Ohm's Law	10
1.4.2 Resistors in Series	12
1.4.3 Resistors in Parallel	13
1.4.4 The Voltage Divider	15
1.4.5 Wire Resistance	16
	<b>vii</b>

1.5	Capacitance	21
1.6	Magnetic Circuits	24
1.6.1	Electromagnetism	24
1.6.2	Magnetic Circuits	26
1.7	Inductance	29
1.7.1	Physics of Inductors	29
1.7.2	Circuit Relationships for Inductors	33
1.8	Transformers	36
1.8.1	Ideal Transformers	37
1.8.2	Magnetization Losses	40
	Problems	44
<b>2</b>	<b>Fundamentals of Electric Power</b>	<b>51</b>
2.1	Effective Values of Voltage and Current	51
2.2	Idealized Components Subjected to Sinusoidal Voltages	55
2.2.1	Ideal Resistors	55
2.2.2	Idealized Capacitors	57
2.2.3	Idealized Inductors	59
2.3	Power Factor	61
2.4	The Power Triangle and Power Factor Correction	63
2.5	Three-Wire, Single-Phase Residential Wiring	67
2.6	Three-Phase Systems	69
2.6.1	Balanced, Wye-Connected Systems	70
2.6.2	Delta-Connected, Three-Phase Systems	76
2.7	Power Supplies	77
2.7.1	Linear Power Supplies	78
2.7.2	Switching Power Supplies	82
2.8	Power Quality	86
2.8.1	Introduction to Harmonics	87
2.8.2	Total Harmonic Distortion	92
2.8.3	Harmonics and Voltage Notching	94
2.8.4	Harmonics and Overloaded Neutrals	95
2.8.5	Harmonics in Transformers	98
	References	99
	Problems	99
<b>3</b>	<b>The Electric Power Industry</b>	<b>107</b>
3.1	The Early Pioneers: Edison, Westinghouse, and Insull	108
3.2	The Electric Utility Industry Today	111

3.2.1	Utilities and Nonutilities	111
3.2.2	Industry Statistics	112
3.3	Polyphase Synchronous Generators	117
3.3.1	A Simple Generator	118
3.3.2	Single-Phase Synchronous Generators	119
3.3.3	Three-Phase Synchronous Generators	121
3.4	Carnot Efficiency for Heat Engines	122
3.4.1	Heat Engines	123
3.4.2	Entropy and the Carnot Heat Engine	123
3.5	Steam-Cycle Power Plants	127
3.5.1	Basic Steam Power Plants	127
3.5.2	Coal-Fired Steam Power Plants	128
3.6	Combustion Gas Turbines	131
3.6.1	Basic Gas Turbine	132
3.6.2	Steam-Injected Gas Turbines (STIG)	133
3.7	Combined-Cycle Power Plants	133
3.8	Gas Turbines and Combined-Cycle Cogeneration	134
3.9	Baseload, Intermediate and Peaking Power Plants	135
3.9.1	Screening Curves	137
3.9.2	Load–Duration Curves	141
3.10	Transmission and Distribution	145
3.10.1	The National Transmission Grid	146
3.10.2	Transmission Lines	148
3.11	The Regulatory Side of Electric Power	151
3.11.1	The Public Utility Holding Company Act of 1935 (PUHCA)	152
3.11.2	The Public Utility Regulatory Policies Act of 1978 (PURPA)	153
3.11.3	The Energy Policy Act of 1992 (EPAAct)	153
3.11.4	FERC Order 888 and Order 2000	154
3.11.5	Utilities and Nonutility Generators	154
3.12	The Emergence of Competitive Markets	155
3.12.1	Technology Motivating Restructuring	156
3.12.2	California Begins to Restructure	157
3.12.3	Collapse of “Deregulation” in California	160
	References	162
	Problems	163

<b>4</b>	<b>Distributed Generation</b>	<b>169</b>
4.1	Electricity Generation in Transition	169
4.2	Distributed Generation with Fossil Fuels	170
4.2.1	HHV and LHV	171
4.2.2	Microcombustion Turbines	172
4.2.3	Reciprocating Internal Combustion Engines	177
4.2.4	Stirling Engines	180
4.3	Concentrating Solar Power (CSP) Technologies	183
4.3.1	Solar Dish/Stirling Power Systems	183
4.3.2	Parabolic Troughs	185
4.3.3	Solar Central Receiver Systems	189
4.3.4	Some Comparisons of Concentrating Solar Power Systems	190
4.4	Biomass for Electricity	192
4.5	Micro-Hydropower Systems	194
4.5.1	Power From a Micro-Hydro Plant	195
4.5.2	Pipe Losses	198
4.5.3	Measuring Flow	201
4.5.4	Turbines	203
4.5.5	Electrical Aspects of Micro-Hydro	205
4.6	Fuel Cells	206
4.6.1	Historical Development	208
4.6.2	Basic Operation of Fuel Cells	209
4.6.3	Fuel Cell Thermodynamics: Enthalpy	210
4.6.4	Entropy and the Theoretical Efficiency of Fuel Cells	213
4.6.5	Gibbs Free Energy and Fuel Cell Efficiency	217
4.6.6	Electrical Output of an Ideal Cell	218
4.6.7	Electrical Characteristics of Real Fuel Cells	219
4.6.8	Types of Fuel Cells	221
4.6.9	Hydrogen Production	224
	References	228
	Problems	229
<b>5</b>	<b>Economics of Distributed Resources</b>	<b>231</b>
5.1	Distributed Resources (DR)	231
5.2	Electric Utility Rate Structures	233
5.2.1	Standard Residential Rates	233
5.2.2	Residential Time-of-Use (TOU) Rates	235
5.2.3	Demand Charges	236
5.2.4	Demand Charges with a Ratchet Adjustment	237

5.2.5	Load Factor	239
5.2.6	Real-Time Pricing (RTP)	240
5.3	Energy Economics	240
5.3.1	Simple Payback Period	241
5.3.2	Initial (Simple) Rate-of-Return	241
5.3.3	Net Present Value	242
5.3.4	Internal Rate of Return (IRR)	244
5.3.5	NPV and IRR with Fuel Escalation	246
5.3.6	Annualizing the Investment	248
5.3.7	Levelized Bus-Bar Costs	251
5.3.8	Cash-Flow Analysis	254
5.4	Energy Conservation Supply Curves	256
5.5	Combined Heat and Power (CHP)	260
5.5.1	Energy-efficiency Measures of Combined Heat and Power (Cogeneration)	261
5.5.2	Impact of Usable Thermal Energy on CHP Economics	264
5.5.3	Design Strategies for CHP	269
5.6	Cooling, Heating, and Cogeneration	271
5.6.1	Compressive Refrigeration	271
5.6.2	Heat Pumps	274
5.6.3	Absorption Cooling	277
5.6.4	Desiccant Dehumidification	278
5.7	Distributed Benefits	280
5.7.1	Option Values	281
5.7.2	Distribution Cost Deferral	286
5.7.3	Electrical Engineering Cost Benefits	287
5.7.4	Reliability Benefits	288
5.7.5	Emissions Benefits	289
5.8	Integrated Resource Planning (IRP) and Demand-Side Management (DSM)	291
5.8.1	Disincentives Caused by Traditional Rate-Making	292
5.8.2	Necessary Conditions for Successful DSM Programs	293
5.8.3	Cost Effectiveness Measures of DSM	295
5.8.4	Achievements of DSM	298
	References	300
	Problems	300

<b>6</b>	<b>Wind Power Systems</b>	<b>307</b>
6.1	Historical Development of Wind Power	307
6.2	Types of Wind Turbines	309
6.3	Power in the Wind	312
	6.3.1 Temperature Correction for Air Density	314
	6.3.2 Altitude Correction for Air Density	316
6.4	Impact of Tower Height	319
6.5	Maximum Rotor Efficiency	323
6.6	Wind Turbine Generators	328
	6.6.1 Synchronous Generators	328
	6.6.2 The Asynchronous Induction Generator	329
6.7	Speed Control for Maximum Power	335
	6.7.1 Importance of Variable Rotor Speeds	335
	6.7.2 Pole-Changing Induction Generators	336
	6.7.3 Multiple Gearboxes	337
	6.7.4 Variable-Slip Induction Generators	337
	6.7.5 Indirect Grid Connection Systems	337
6.8	Average Power in the Wind	338
	6.8.1 Discrete Wind Histogram	338
	6.8.2 Wind Power Probability Density Functions	342
	6.8.3 Weibull and Rayleigh Statistics	343
	6.8.4 Average Power in the Wind with Rayleigh Statistics	345
	6.8.5 Wind Power Classifications and U.S. Potential	347
6.9	Simple Estimates of Wind Turbine Energy	349
	6.9.1 Annual Energy Using Average Wind Turbine Efficiency	350
	6.9.2 Wind Farms	351
6.10	Specific Wind Turbine Performance Calculations	354
	6.10.1 Some Aerodynamics	354
	6.10.2 Idealized Wind Turbine Power Curve	355
	6.10.3 Optimizing Rotor Diameter and Generator Rated Power	357
	6.10.4 Wind Speed Cumulative Distribution Function	357
	6.10.5 Using Real Power Curves with Weibull Statistics	361
	6.10.6 Using Capacity Factor to Estimate Energy Produced	367
6.11	Wind Turbine Economics	371
	6.11.1 Capital Costs and Annual Costs	371
	6.11.2 Annualized Cost of Electricity from Wind Turbines	373
6.12	Environmental Impacts of Wind Turbines	377

References	378
Problems	379
<b>7 The Solar Resource</b>	<b>385</b>
7.1 The Solar Spectrum	385
7.2 The Earth's Orbit	390
7.3 Altitude Angle of the Sun at Solar Noon	391
7.4 Solar Position at any Time of Day	395
7.5 Sun Path Diagrams for Shading Analysis	398
7.6 Solar Time and Civil (Clock) Time	402
7.7 Sunrise and Sunset	404
7.8 Clear Sky Direct-Beam Radiation	410
7.9 Total Clear Sky Insolation on a Collecting Surface	413
7.9.1 Direct-Beam Radiation	413
7.9.2 Diffuse Radiation	415
7.9.3 Reflected Radiation	417
7.9.4 Tracking Systems	419
7.10 Monthly Clear-Sky Insolation	424
7.11 Solar Radiation Measurements	428
7.12 Average Monthly Insolation	431
References	439
Problems	439
<b>8 Photovoltaic Materials and Electrical Characteristics</b>	<b>445</b>
8.1 Introduction	445
8.2 Basic Semiconductor Physics	448
8.2.1 The Band Gap Energy	448
8.2.2 The Solar Spectrum	452
8.2.3 Band-Gap Impact on Photovoltaic Efficiency	453
8.2.4 The $p-n$ Junction	455
8.2.5 The $p-n$ Junction Diode	458
8.3 A Generic Photovoltaic Cell	460
8.3.1 The Simplest Equivalent Circuit for a Photovoltaic Cell	460
8.3.2 A More Accurate Equivalent Circuit for a PV Cell	464
8.4 From Cells to Modules to Arrays	468
8.4.1 From Cells to a Module	468
8.4.2 From Modules to Arrays	471
8.5 The PV $I-V$ Curve Under Standard Test Conditions (STC)	473
8.6 Impacts of Temperature and Insolation on $I-V$ Curves	475

8.7	Shading impacts on I–V curves	477
8.7.1	Physics of Shading	478
8.7.2	Bypass Diodes for Shade Mitigation	481
8.7.3	Blocking Diodes	485
8.8	Crystalline Silicon Technologies	485
8.8.1	Single-Crystal Czochralski (CZ) Silicon	486
8.8.2	Ribbon Silicon Technologies	489
8.8.3	Cast Multicrystalline Silicon	491
8.8.4	Crystalline Silicon Modules	491
8.9	Thin-Film Photovoltaics	492
8.9.1	Amorphous Silicon	493
8.9.2	Gallium Arsenide and Indium Phosphide	498
8.9.3	Cadmium Telluride	499
8.9.4	Copper Indium Diselenide (CIS)	500
	References	501
	Problems	502
<b>9</b>	<b>Photovoltaic Systems</b>	<b>505</b>
9.1	Introduction to the Major Photovoltaic System Types	505
9.2	Current–Voltage Curves for Loads	508
9.2.1	Simple Resistive-Load $I-V$ Curve	508
9.2.2	DC Motor $I-V$ Curve	510
9.2.3	Battery $I-V$ Curves	512
9.2.4	Maximum Power Point Trackers	514
9.2.5	Hourly $I-V$ Curves	518
9.3	Grid-Connected Systems	521
9.3.1	Interfacing with the Utility	523
9.3.2	DC and AC Rated Power	525
9.3.3	The “Peak-Hours” Approach to Estimating PV Performance	528
9.3.4	Capacity Factors for PV Grid-Connected Systems	533
9.3.5	Grid-Connected System Sizing	534
9.4	Grid-Connected PV System Economics	542
9.4.1	System Trade-offs	542
9.4.2	Dollar-per-Watt Ambiguities	544
9.4.3	Amortizing Costs	545
9.5	Stand-Alone PV Systems	550
9.5.1	Estimating the Load	551
9.5.2	The Inverter and the System Voltage	554



9.5.3	Batteries	557
9.5.4	Basics of Lead-Acid Batteries	559
9.5.5	Battery Storage Capacity	562
9.5.6	Coulomb Efficiency Instead of Energy Efficiency	565
9.5.7	Battery Sizing	568
9.5.8	Blocking Diodes	572
9.5.9	Sizing the PV Array	575
9.5.10	Hybrid PV Systems	579
9.5.11	Stand-Alone System Design Summary	580
9.6	PV-Powered Water Pumping	584
9.6.1	Hydraulic System Curves	585
9.6.2	Hydraulic Pump Curves	588
9.6.3	Hydraulic System Curve and Pump Curve Combined	591
9.6.4	A Simple Directly Coupled PV–Pump Design Approach	592
	References	595
	Problems	595
<b>APPENDIX A</b>	<b>Useful Conversion Factors</b>	<b>606</b>
<b>APPENDIX B</b>	<b>Sun-Path Diagrams</b>	<b>611</b>
<b>APPENDIX C</b>	<b>Hourly Clear-Sky Insolation Tables</b>	<b>615</b>
<b>APPENDIX D</b>	<b>Monthly Clear-Sky Insolation Tables</b>	<b>625</b>
<b>APPENDIX E</b>	<b>Solar Insolation Tables by City</b>	<b>629</b>
<b>APPENDIX F</b>	<b>Maps of Solar Insolation</b>	<b>641</b>
	<b>Index</b>	<b>647</b>

## CHAPTER 6

---

# WIND POWER SYSTEMS

---

### 6.1 HISTORICAL DEVELOPMENT OF WIND POWER

Wind has been utilized as a source of power for thousands of years for such tasks as propelling sailing ships, grinding grain, pumping water, and powering factory machinery. The world's first wind turbine used to generate electricity was built by a Dane, Poul la Cour, in 1891. It is especially interesting to note that La Cour used the electricity generated by his turbines to electrolyze water, producing hydrogen for gas lights in the local schoolhouse. In that regard we could say that he was 100 years ahead of his time since the vision that many have for the twenty-first century includes photovoltaic and wind power systems making hydrogen by electrolysis to generate electric power in fuel cells.

In the United States the first wind-electric systems were built in the late 1890s; by the 1930s and 1940s, hundreds of thousands of small-capacity, wind-electric systems were in use in rural areas not yet served by the electricity grid. In 1941 one of the largest wind-powered systems ever built went into operation at Grandpa's Knob in Vermont. Designed to produce 1250 kW from a 175-ft-diameter, two-bladed prop, the unit had withstood winds as high as 115 miles per hour before it catastrophically failed in 1945 in a modest 25-mph wind (one of its 8-ton blades broke loose and was hurled 750 feet away).

Subsequent interest in wind systems declined as the utility grid expanded and became more reliable and electricity prices declined. The oil shocks of the 1970s, which heightened awareness of our energy problems, coupled with substantial financial and regulatory incentives for alternative energy systems, stimulated a renewal of interest in windpower. Within a decade or so, dozens of manufacturers installed thousands of new wind turbines (mostly in California). While many of those machines performed below expectations, the tax credits and other incentives deserve credit for shortening the time required to sort out the best technologies. The wind boom in California was short-lived, and when the tax credits were terminated in the mid-1980s, installation of new machines in the United States stopped almost completely for a decade. Since most of the world's wind-power sales, up until about 1985, were in the United States, this sudden drop in the market practically wiped out the industry worldwide until the early 1990s.

Meanwhile, wind turbine technology development continued—especially in Denmark, Germany, and Spain—and those countries were ready when sales began to boom in the mid-1990s. As shown in Fig. 6.1, the global installed capacity of wind turbines has been growing at over 25% per year.

Globally, the countries with the most installed wind capacity are shown in Fig. 6.2. As of 2003, the world leader is Germany, followed by Spain, the United States, Denmark, and India. In the United States, California continues to have the most installed capacity, but as shown in Fig. 6.3, Texas is rapidly closing the gap. Large numbers of turbines have been installed along the Columbia River Gorge in the Pacific Northwest, and the windy Great Plains states are experiencing major growth as well.

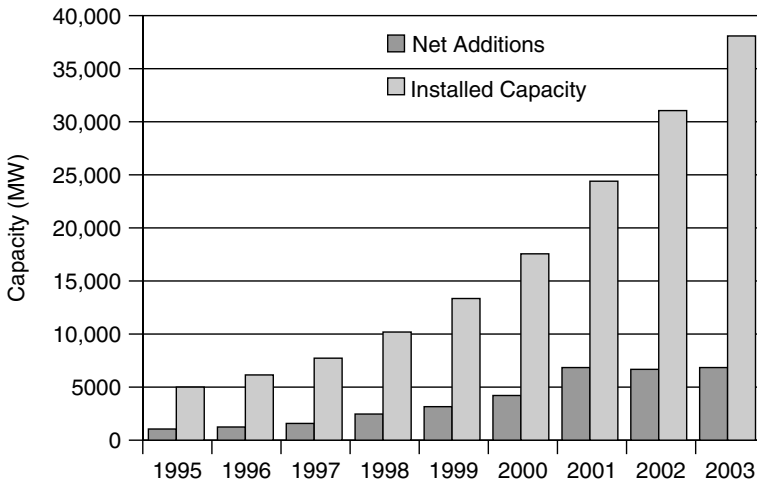

**Figure 6.1** Worldwide installed wind-power capacity and net annual additions to capacity have grown by over 25% per year since the mid-1990s. Data from AWEA.

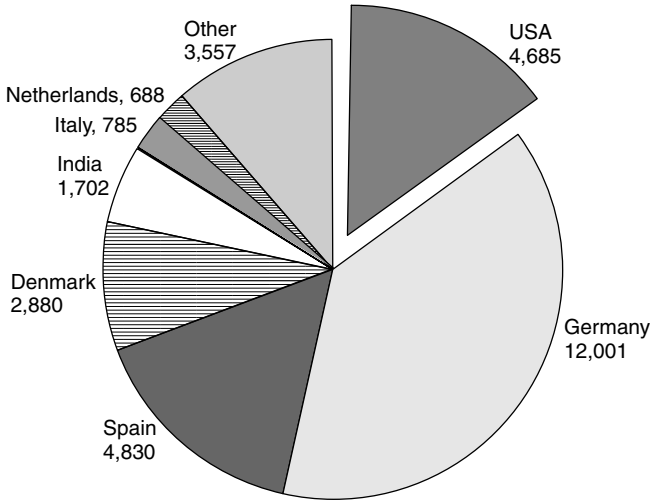

Figure 6.2 Total installed capacity in 2002, by country. AWEA data.

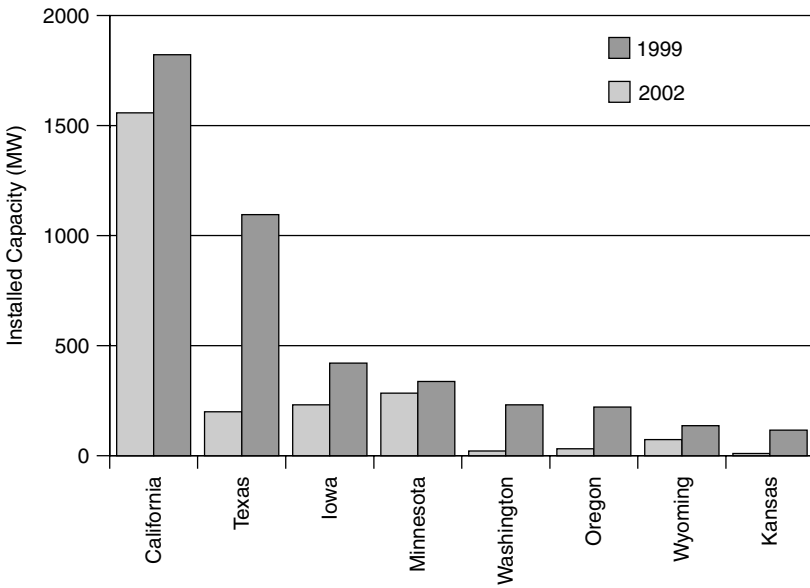

Figure 6.3 Installed wind capacity in the United States in 1999 and 2002.

## 6.2 TYPES OF WIND TURBINES

Most early wind turbines were used to grind grain into flour, hence the name “windmill.” Strictly speaking, therefore, calling a machine that pumps water or generates electricity a windmill is somewhat of a misnomer. Instead, people are

using more accurate, but generally clumsier, terminology: “Wind-driven generator,” “wind generator,” “wind turbine,” “wind-turbine generator” (WTG), and “wind energy conversion system” (WECS) all are in use. For our purposes, “wind turbine” will suffice even though often we will be talking about system components (e.g., towers, generators, etc.) that clearly are not part of a “turbine.”

One way to classify wind turbines is in terms of the axis around which the turbine blades rotate. Most are horizontal axis wind turbines (HAWT), but there are some with blades that spin around a vertical axis (VAWT). Examples of the two types are shown in Fig. 6.4.

The only vertical axis machine that has had any commercial success is the Darrieus rotor, named after its inventor the French engineer G. M. Darrieus, who first developed the turbines in the 1920s. The shape of the blades is that which would result from holding a rope at both ends and spinning it around a vertical axis, giving it a look that is not unlike a giant eggbeater. Considerable development of these turbines, including a 500-kW, 34-m diameter machine, was undertaken in the 1980s by Sandia National Laboratories in the United States. An American company, FloWind, manufactured and installed a number of these wind turbines before leaving the business in 1997.

The principal advantage of vertical axis machines, such as the Darrieus rotor, is that they don’t need any kind of yaw control to keep them facing into the wind. A second advantage is that the heavy machinery contained in the *nacelle* (the housing around the generator, gear box, and other mechanical components) can be located down on the ground, where it can be serviced easily. Since the heavy equipment is not perched on top of a tower, the tower itself need not be structurally as strong as that for a HAWT. The tower can be lightened even further when guy wires are used, which is fine for towers located on land but not for offshore installations. The blades on a Darrieus rotor, as they spin around, are almost always in pure tension, which means that they can be relatively lightweight

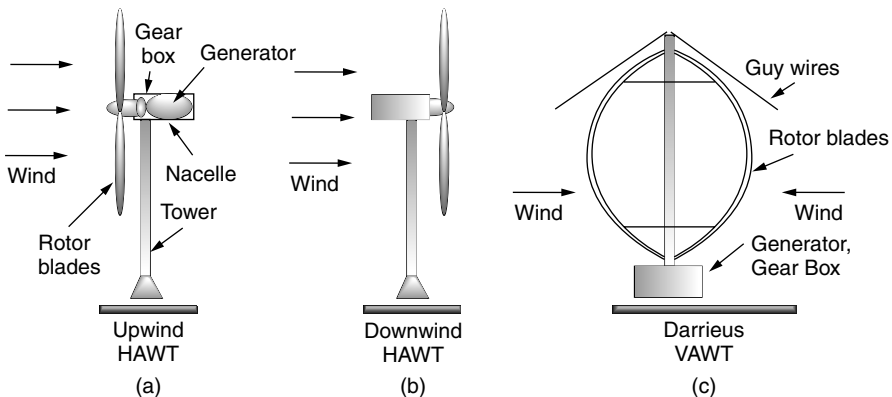

**Figure 6.4** Horizontal axis wind turbines (HAWT) are either upwind machines (a) or downwind machines (b). Vertical axis wind turbines (VAWT) accept the wind from any direction (c).

and inexpensive since they don't have to handle the constant flexing associated with blades on horizontal axis machines.

There are several disadvantages of vertical axis turbines, the principal one being that the blades are relatively close to the ground where windspeeds are lower. As we will see later, power in the wind increases as the cube of velocity so there is considerable incentive to get the blades up into the faster windspeeds that exist higher up. Winds near the surface of the earth are not only slower but also more turbulent, which increases stresses on VAWTs. Finally, in low-speed winds, Darrieus rotors have very little starting torque; in higher winds, when output power must be controlled to protect the generator, they can't be made to spill the wind as easily as pitch-controlled blades on a HAWT.

While almost all wind turbines are of the horizontal axis type, there is still some controversy over whether an upwind machine or a downwind machine is best. A downwind machine has the advantage of letting the wind itself control the yaw (the left-right motion) so it naturally orients itself correctly with respect to wind direction. They do have a problem, however, with wind shadowing effects of the tower. Every time a blade swings behind the tower, it encounters a brief period of reduced wind, which causes the blade to flex. This flexing not only has the potential to lead to blade failure due to fatigue, but also increases blade noise and reduces power output.

Upwind turbines, on the other hand, require somewhat complex yaw control systems to keep the blades facing into the wind. In exchange for that added complexity, however, upwind machines operate more smoothly and deliver more power. Most modern wind turbines are of the upwind type.

Another fundamental design decision for wind turbines relates to the number of rotating blades. Perhaps the most familiar wind turbine for most people is the multibladed, water-pumping windmill so often seen on farms. These machines are radically different from those designed to generate electricity. For water pumping, the windmill must provide high starting torque to overcome the weight and friction of the pumping rod that moves up and down in the well. They must also operate in low windspeeds in order to provide nearly continuous water pumping throughout the year. Their multibladed design presents a large area of rotor facing into the wind, which enables both high-torque and low-speed operation.

Wind turbines with many blades operate with much lower rotational speed than those with fewer blades. As the rpm of the turbine increases, the turbulence caused by one blade affects the efficiency of the blade that follows. With fewer blades, the turbine can spin faster before this interference becomes excessive. And a faster spinning shaft means that generators can be physically smaller in size.

Most modern European wind turbines have three rotor blades, while American machines have tended to have just two. Three-bladed turbines show smoother operation since impacts of tower interference and variation of windspeed with height are more evenly transferred from rotors to drive shaft. They also tend to be quieter. The third blade, however, does add considerably to the weight and cost of the turbine. A three-bladed rotor also is somewhat more difficult to hoist up to the nacelle during construction or blade replacement. It is interesting to

note that one-bladed turbines (with a counterweight) have been tried, but never deemed worth pursuing.

### 6.3 POWER IN THE WIND

Consider a “packet” of air with mass  $m$  moving at a speed  $v$ . Its kinetic energy K.E., is given by the familiar relationship:

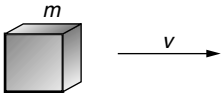

$$\text{K.E.} = \frac{1}{2}mv^2 \quad (6.1)$$

Since power is energy per unit time, the power represented by a mass of air moving at velocity  $v$  through area  $A$  will be

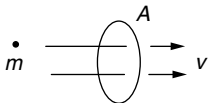

$$\text{Power through area } A = \frac{\text{Energy}}{\text{Time}} = \frac{1}{2} \left( \frac{\text{Mass}}{\text{Time}} \right) v^2 \quad (6.2)$$

The mass flow rate  $\dot{m}$ , through area  $A$ , is the product of air density  $\rho$ , speed  $v$ , and cross-sectional area  $A$ :

$$\left( \frac{\text{Mass passing through } A}{\text{Time}} \right) = \dot{m} = \rho Av \quad (6.3)$$

Combining (6.3) with (6.2) gives us an important relationship:

$$P_w = \frac{1}{2} \rho Av^3 \quad (6.4)$$

In S.I. units;  $P_w$  is the power in the wind (watts);  $\rho$  is the air density ( $\text{kg/m}^3$ ) (at  $15^\circ\text{C}$  and 1 atm,  $\rho = 1.225 \text{ kg/m}^3$ );  $A$  is the cross-sectional area through which the wind passes ( $\text{m}^2$ ); and  $v =$  windspeed normal to  $A$  ( $\text{m/s}$ ) (a useful conversion:  $1 \text{ m/s} = 2.237 \text{ mph}$ ).

A plot of (6.4) and a table of values are shown in Fig. 6.5. Notice that the power shown there is per square meter of cross section, a quantity that is called the *specific power* or *power density*.

Notice that the power in the wind increases as the *cube* of windspeed. This means, for example, that doubling the windspeed increases the power by eight-fold. Another way to look at it is that the energy contained in 1 hour of 20 mph winds is the same as that contained in 8 hours at 10 mph, which is the same as that contained in 64 hours (more than  $2 \frac{1}{2}$  days) of 5 mph wind. Later we will see that most wind turbines aren’t even turned on in low-speed winds, and (6.4) reminds us that the lost energy can be negligible.

Equation (6.4) also indicates that wind power is proportional to the swept area of the turbine rotor. For a conventional horizontal axis turbine, the area

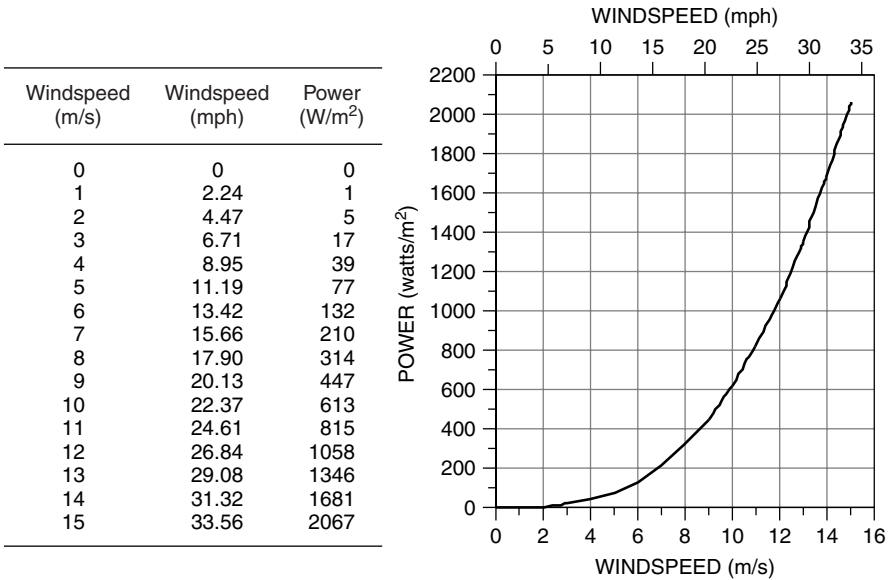

**Figure 6.5** Power in the wind, per square meter of cross section, at 15°C and 1 atm.

$A$  is obviously just  $A = (\pi/4)D^2$ , so windpower is proportional to the square of the blade diameter. Doubling the diameter increases the power available by a factor of four. That simple observation helps explain the economies of scale that go with larger wind turbines. The cost of a turbine increases roughly in proportion to blade diameter, but power is proportional to diameter squared, so bigger machines have proven to be more cost effective.

The swept area of a vertical axis Darrieus rotor is a bit more complicated to figure out. One approximation to the area is that it is about two-thirds the area of a rectangle with width equal to the maximum rotor width and height equal to the vertical extent of the blades, as shown in Fig. 6.6.

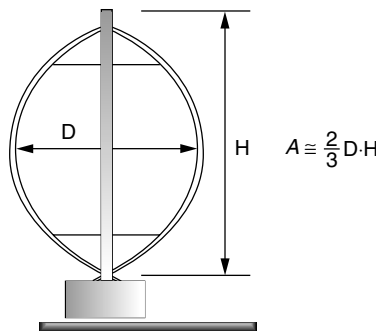

**Figure 6.6** Showing the approximate area of a Darrieus rotor.



Of obvious interest is the energy in a combination of windspeeds. Given the nonlinear relationship between power and wind, we can't just use *average* windspeed in (6.4) to predict total energy available, as the following example illustrates.

---

**Example 6.1 Don't Use Average Windspeed.** Compare the energy at 15°C, 1 atm pressure, contained in 1 m<sup>2</sup> of the following wind regimes:

- a. 100 hours of 6-m/s winds (13.4 mph),
- b. 50 hours at 3 m/s plus 50 hours at 9 m/s (i.e., an average windspeed of 6 m/s)

**Solution**

- a. With steady 6 m/s winds, all we have to do is multiply power given by (6.4) times hours:

$$\begin{aligned} \text{Energy (6 m/s)} &= \frac{1}{2} \rho A v^3 \Delta t = \frac{1}{2} \cdot 1.225 \text{ kg/m}^3 \cdot 1 \text{ m}^2 \cdot (6 \text{ m/s})^3 \cdot 100 \text{ h} \\ &= 13,230 \text{ Wh} \end{aligned}$$

- b. With 50 h at 3 m/s

$$\text{Energy (3 m/s)} = \frac{1}{2} \cdot 1.225 \text{ kg/m}^3 \cdot 1 \text{ m}^2 \cdot (3 \text{ m/s})^3 \cdot 50 \text{ h} = 827 \text{ Wh}$$

And 50 h at 9 m/s contain

$$\text{Energy (9 m/s)} = \frac{1}{2} \cdot 1.225 \text{ kg/m}^3 \cdot 1 \text{ m}^2 \cdot (9 \text{ m/s})^3 \cdot 50 \text{ h} = 22,326 \text{ Wh}$$

for a total of  $827 + 22,326 = 23,152 \text{ Wh}$

---

Example 6.1 dramatically illustrates the inaccuracy associated with using average windspeeds in (6.4). While both of the wind regimes had the same *average* windspeed, the combination of 9-m/s and 3-m/s winds (average 6 m/s) produces 75% more energy than winds blowing a steady 6 m/s. Later we will see that, under certain common assumptions about windspeed probability distributions, energy in the wind is typically almost twice the amount that would be found by using the average windspeed in (6.4).

### 6.3.1 Temperature Correction for Air Density

When wind power data are presented, it is often assumed that the air density is 1.225 kg/m<sup>3</sup>; that is, it is assumed that air temperature is 15°C (59°F) and

pressure is 1 atmosphere. Using the ideal gas law, we can easily determine the air density under other conditions.

$$PV = nRT \quad (6.5)$$

where  $P$  is the absolute pressure (atm),  $V$  is the volume ( $\text{m}^3$ ),  $n$  is the mass (mol),  $R$  is the ideal gas constant  $= 8.2056 \times 10^{-5} \text{ m}^3 \cdot \text{atm} \cdot \text{K}^{-1} \cdot \text{mol}^{-1}$ , and  $T$  is the absolute temperature (K), where  $K = ^\circ\text{C} + 273.15$ . One atmosphere of pressure equals 101.325 kPa (Pa is the abbreviation for pascals, where  $1 \text{ Pa} = 1 \text{ newton/m}^2$ ). One atmosphere is also equal to 14.7 pounds per square inch (psi), so  $1 \text{ psi} = 6.89 \text{ kPa}$ . Finally, 100 kPa is called a *bar* and 100 Pa is a millibar, which is the unit of pressure often used in meteorology work.

If we let M.W. stand for the molecular weight of the gas (g/mol), we can write the following expression for air density,  $\rho$ :

$$\rho(\text{kg/m}^3) = \frac{n(\text{mol}) \cdot \text{M.W.}(\text{g/mol}) \cdot 10^{-3}(\text{kg/g})}{V(\text{m}^3)} \quad (6.6)$$

Combining (6.5) and (6.6) gives us the following expression:

$$\rho = \frac{P \times \text{M.W.} \times 10^{-3}}{RT} \quad (6.7)$$

All we need is the molecular weight of air. Air, of course, is a mix of molecules, mostly nitrogen (78.08%) and oxygen (20.95%), with a little bit of argon (0.93%), carbon dioxide (0.035%), neon (0.0018%), and so forth. Using the constituent molecular weights ( $\text{N}_2 = 28.02$ ,  $\text{O}_2 = 32.00$ ,  $\text{Ar} = 39.95$ ,  $\text{CO}_2 = 44.01$ ,  $\text{Ne} = 20.18$ ), we find the equivalent molecular weight of air to be  $28.97$  ( $0.7808 \times 28.02 + 0.2095 \times 32.00 + 0.0093 \times 39.95 + 0.00035 \times 44.01 + 0.000018 \times 20.18 = 28.97$ ).

---

**Example 6.2 Density of Warmer Air.** Find the density of air at 1 atm and  $30^\circ\text{C}$  ( $86^\circ\text{F}$ )

**Solution.** From (6.7),

$$\rho = \frac{1 \text{ atm} \times 28.97 \text{ g/mol} \times 10^{-3} \text{ kg/g}}{8.2056 \times 10^{-5} \text{ m}^3 \cdot \text{atm}/(\text{K} \cdot \text{mol}) \times (273.15 + 30) \text{ K}} = 1.165 \text{ kg/m}^3$$

which is a 5% decrease in density compared to the reference  $1.225 \text{ kg/m}^3$ ; since power is proportional to density, it is also a 5% decrease in power in the wind.

---

**TABLE 6.1 Density of Dry Air at a Pressure of 1 Atmosphere<sup>a</sup>**

Temperature (°C)	Temperature (°F)	Density (kg/m <sup>3</sup> )	Density Ratio ( $K_T$ )
-15	5.0	1.368	1.12
-10	14.0	1.342	1.10
-5	23.0	1.317	1.07
0	32.0	1.293	1.05
5	41.0	1.269	1.04
10	50.0	1.247	1.02
<b>15</b>	<b>59.0</b>	<b>1.225</b>	1.00
20	68.0	1.204	0.98
25	77.0	1.184	0.97
30	86.0	1.165	0.95
35	95.0	1.146	0.94
40	104.0	1.127	0.92

<sup>a</sup>The density ratio  $K_T$  is the ratio of density at  $T$  to the density at the standard (boldfaced) 15°C.

For convenience, Table 6.1 shows air density for a range of temperatures.

**6.3.2 Altitude Correction for Air Density**

Air density, and hence power in the wind, depends on atmospheric pressure as well as temperature. Since air pressure is a function of altitude, it is useful to have a correction factor to help estimate wind power at sites above sea level.

Consider a static column of air with cross section  $A$ , as shown in Fig. 6.7. A horizontal slice of air in that column of thickness  $dz$  and density  $\rho$  will have mass  $\rho A dz$ . If the pressure at the top of the slice due to the weight of the air above it is  $P(z + dz)$ , then the pressure at the bottom of the slice,  $P(z)$ , will be

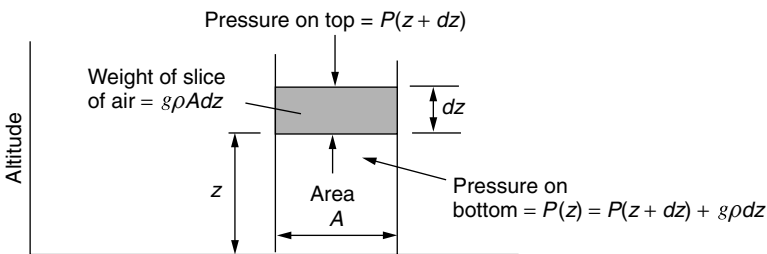

**Figure 6.7** A column of air in static equilibrium used to determine the relationship between air pressure and altitude.

$P(z + dz)$  plus the added weight per unit area of the slice itself:

$$P(z) = P(z + dz) + \frac{g\rho A dz}{A} \quad (6.8)$$

where  $g$  is the gravitational constant,  $9.806 \text{ m/s}^2$ . Thus we can write the incremental pressure  $dP$  for an incremental change in elevation,  $dz$  as

$$dP = P(z + dz) - P(z) = -g \rho dz \quad (6.9)$$

That is,

$$\frac{dP}{dz} = -\rho g \quad (6.10)$$

The air density  $\rho$  given in (6.10) is itself a function of pressure as described in (6.7), so we can now write

$$\frac{dP}{dz} = -\left(\frac{g \text{ M.W.} \times 10^{-3}}{R \cdot T}\right) \cdot P \quad (6.11)$$

To further complicate things, temperature throughout the air column is itself changing with altitude, typically at the rate of about  $6.5^\circ\text{C}$  drop per kilometer of increasing elevation. If, however, we make the simplifying assumption that  $T$  is a constant throughout the air column, we can easily solve (6.11) while introducing only a slight error. Plugging in the constants and conversion factors, while assuming  $15^\circ\text{C}$ , gives

$$\begin{aligned} \frac{dP}{dz} &= -\left[ \frac{9.806(\text{m/s}^2) \times 28.97(\text{g/mol}) \times 10^{-3}(\text{kg/g})}{8.2056 \times 10^{-5}(\text{m}^3 \cdot \text{atm} \cdot \text{K}^{-1} \cdot \text{mol}^{-1}) \times 288.15 \text{ K}} \right] \\ &\quad \times \left( \frac{\text{atm}}{101,325 \text{ Pa}} \right) \cdot \left( \frac{1 \text{ Pa}}{\text{N/m}^2} \right) \left( \frac{1 \text{ N}}{\text{kg} \cdot \text{m/s}^2} \right) \cdot P \\ \frac{dP}{dz} &= -1.185 \times 10^{-4} P \end{aligned} \quad (6.12)$$

which has solution,

$$P = P_0 e^{-1.185 \times 10^{-4} H} = 1(\text{atm}) \cdot e^{-1.185 \times 10^{-4} H} \quad (6.13)$$

where  $P_0$  is the reference pressure of 1 atm and  $H$  is in meters.

---

**Example 6.3 Density at Higher Elevations.** Find the air density (a), at  $15^\circ\text{C}$  (288.15 K), at an elevation of 2000 m (6562 ft). Then (b) find it assuming an air temperature of  $5^\circ\text{C}$  at 2000 m.

**Solution**

- a. From (6.13),  $P = 1 \text{ atm} \times e^{-1.185 \times 10^{-4} \times 2000} = 0.789 \text{ atm}$   
 From (6.7),

$$\begin{aligned} \rho &= \frac{P \cdot \text{M.W.} \cdot 10^{-3}}{R \cdot T} \\ &= \frac{0.789(\text{atm}) \times 28.97(\text{g/mol}) \times 10^{-3}(\text{kg/g})}{8.2056 \times 10^{-5}(\text{m}^3 \cdot \text{atm} \cdot \text{K}^{-1} \cdot \text{mol}^{-1}) \times 288.15 \text{ K}} \\ &= 0.967 \text{ kg/m}^3 \end{aligned}$$

- b. At  $5^\circ\text{C}$  and 2000 m, the air density would be

$$\begin{aligned} \rho &= \frac{0.789(\text{atm}) \times 28.97(\text{g/mol}) \times 10^{-3}(\text{kg/g})}{8.2056 \times 10^{-5}(\text{m}^3 \cdot \text{atm} \cdot \text{K}^{-1} \cdot \text{mol}^{-1}) \times (273.15 + 5) \text{ K}} \\ &= 1.00 \text{ kg/m}^3 \end{aligned}$$

Table 6.2 summarizes some pressure correction factors based on (6.13). A simple way to combine the temperature and pressure corrections for density is as follows:

$$\rho = 1.225 K_T K_A \quad (6.14)$$

In (6.14), the correction factors  $K_T$  for temperature and  $K_A$  for altitude are tabulated in Tables 6.1 and 6.2.

**TABLE 6.2 Air Pressure at  $15^\circ\text{C}$  as a Function of Altitude**

Altitude (meters)	Altitude (feet)	Pressure (atm)	Pressure Ratio ( $K_A$ )
0	0	1	1
200	656	0.977	0.977
400	1312	0.954	0.954
600	1968	0.931	0.931
800	2625	0.910	0.910
1000	3281	0.888	0.888
1200	3937	0.868	0.868
1400	4593	0.847	0.847
1600	5249	0.827	0.827
1800	5905	0.808	0.808
2000	6562	0.789	0.789
2200	7218	0.771	0.771

**Example 6.4 Combined Temperature and Altitude Corrections.** Find the power density ( $\text{W}/\text{m}^2$ ) in 10 m/s wind at an elevation of 2000 m and a temperature of  $5^\circ\text{C}$ .

**Solution.** Using  $K_T$  and  $K_A$  factors from Tables 6.1 and 6.2 along with (6.14) gives

$$\rho = 1.225 K_T K_A = 1.225 \times 1.04 \times 0.789 = 1.00 \text{ kg}/\text{m}^3$$

which agrees with the answer found in Example 6.3. The power density in 10 m/s winds is therefore

$$\frac{P}{A} = \frac{1}{2} \rho v^3 = \frac{1}{2} \cdot 1.00 \cdot 10^3 = 500 \text{ W}/\text{m}^2$$

## 6.4 IMPACT OF TOWER HEIGHT

Since power in the wind is proportional to the cube of the windspeed, the economic impact of even modest increases in windspeed can be significant. One way to get the turbine into higher winds is to mount it on a taller tower. In the first few hundred meters above the ground, wind speed is greatly affected by the friction that the air experiences as it moves across the earth's surface. Smooth surfaces, such as a calm sea, offer very little resistance, and the variation of speed with elevation is only modest. At the other extreme, surface winds are slowed considerably by high irregularities such as forests and buildings.

One expression that is often used to characterize the impact of the roughness of the earth's surface on windspeed is the following:

$$\left(\frac{v}{v_0}\right) = \left(\frac{H}{H_0}\right)^\alpha \tag{6.15}$$

where  $v$  is the windspeed at height  $H$ ,  $v_0$  is the windspeed at height  $H_0$  (often a reference height of 10 m), and  $\alpha$  is the friction coefficient.

The friction coefficient  $\alpha$  is a function of the terrain over which the wind blows. Table 6.3 gives some representative values for rather loosely defined terrain types. Oftentimes, for rough approximations in somewhat open terrain a value of  $1/7$  (the "one-seventh" rule-of-thumb) is used for  $\alpha$ .

While the power law given in (6.15) is very often used in the United States, there is another approach that is common in Europe. The alternative formulation is

$$\left(\frac{v}{v_0}\right) = \frac{\ln(H/z)}{\ln(H_0/z)} \tag{6.16}$$

**TABLE 6.3 Friction Coefficient for Various Terrain Characteristics**

Terrain Characteristics	Friction Coefficient $\alpha$
Smooth hard ground, calm water	0.10
Tall grass on level ground	0.15
High crops, hedges and shrubs	0.20
Wooded countryside, many trees	0.25
Small town with trees and shrubs	0.30
Large city with tall buildings	0.40

**TABLE 6.4 Roughness Classifications for Use in (6.16)**

Roughness Class	Description	Roughness Length $z(m)$
0	Water surface	0.0002
1	Open areas with a few windbreaks	0.03
2	Farm land with some windbreaks more than 1 km apart	0.1
3	Urban districts and farm land with many windbreaks	0.4
4	Dense urban or forest	1.6

where  $z$  is called the roughness length. A table of roughness classifications and roughness lengths is given in Table 6.4. Equation (6.16) is preferred by some since it has a theoretical basis in aerodynamics while (6.15) does not.\* In this chapter, we will stick with the exponential expression (6.15). Obviously, both the exponential formulation in (6.15) and the logarithmic version of (6.16) only provide a first approximation to the variation of windspeed with elevation. In reality, nothing is better than actual site measurements.

Figure 6.8a shows the impact of friction coefficient on windspeed assuming a reference height of 10 m, which is a commonly used standard elevation for an anemometer. As can be seen from the figure, for a smooth surface ( $\alpha = 0.1$ ), the wind at 100 m is only about 25% higher than at 10 m, while for a site in a “small town” ( $\alpha = 0.3$ ), the wind at 100 m is estimated to be twice that at 10 m. The impact of height on power is even more impressive as shown in Fig. 6.8b.

\*When the atmosphere is thermally neutral—that is, it cools with a gradient of  $-9.8^\circ\text{C}/\text{km}$ —the air flow within the boundary layer should theoretically vary logarithmically, starting with a windspeed of zero at a distance above ground equal to the roughness length.

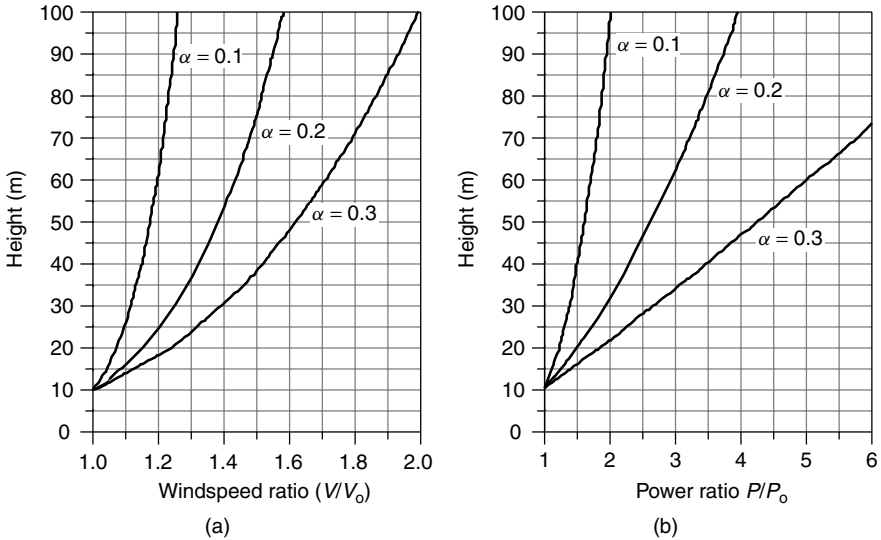

**Figure 6.8** Increasing (a) windspeed and (b) power ratios with height for various friction coefficients  $\alpha$  using a reference height of 10 m. For  $\alpha = 0.2$  (hedges and crops) at 50 m, windspeed increases by a factor of almost 1.4 and wind power increases by about 2.6.

---

**Example 6.5 Increased Windpower with a Taller Tower.** An anemometer mounted at a height of 10 m above a surface with crops, hedges, and shrubs shows a windspeed of 5 m/s. Estimate the windspeed and the specific power in the wind at a height of 50 m. Assume 15°C and 1 atm of pressure.

**Solution.** From Table 6.3, the friction coefficient  $\alpha$  for ground with hedges, and so on, is estimated to be 0.20. From the 15°C, 1-atm conditions, the air density is  $\rho = 1.225 \text{ kg/m}^3$ . Using (6.15), the windspeed at 50 m will be

$$v_{50} = 5 \cdot \left(\frac{50}{10}\right)^{0.20} = 6.9 \text{ m/s}$$

Specific power will be

$$P_{50} = \frac{1}{2}\rho v^3 = 0.5 \times 1.225 \times 6.9^3 = 201 \text{ W/m}^2$$

That turns out to be more than two and one-half times as much power as the 76.5 W/m<sup>2</sup> available at 10 m.

---

Since power in the wind varies as the cube of windspeed, we can rewrite (6.15) to indicate the relative power of the wind at height  $H$  versus the power at the



reference height of  $H_0$ :

$$\left(\frac{P}{P_0}\right) = \left(\frac{1/2\rho Av^3}{1/2\rho Av_0^3}\right) = \left(\frac{v}{v_0}\right)^3 = \left(\frac{H}{H_0}\right)^{3\alpha} \quad (6.17)$$

In Figure 6.8b, the ratio of wind power at other elevations to that at 10 m shows the dramatic impact of the cubic relationship between windspeed and power. Even for a smooth ground surface—for instance, for an offshore site—the power doubles when the height increases from 10 m to 100 m. For a rougher surface, with friction coefficient  $\alpha = 0.3$ , the power doubles when the height is raised to just 22 m, and it is quadrupled when the height is raised to 47 m.

---

**Example 6.6 Rotor Stress.** A wind turbine with a 30-m rotor diameter is mounted with its hub at 50 m above a ground surface that is characterized by shrubs and hedges. Estimate the ratio of specific power in the wind at the highest point that a rotor blade tip reaches to the lowest point that it falls to.

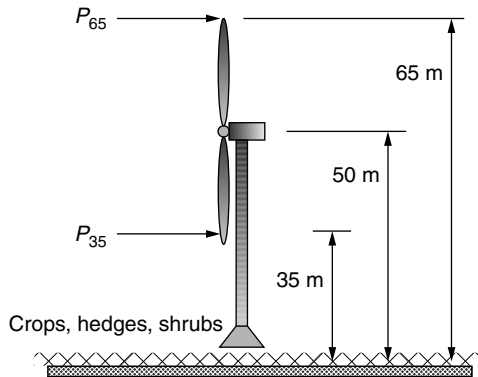

**Solution.** From Table 6.3, the friction coefficient  $\alpha$  for ground with hedges and shrubs is estimated to be 0.20. Using (6.17), the ratio of power at the top of the blade swing (65 m) to that at the bottom of its swing (35 m) will be

$$\left(\frac{P}{P_0}\right) = \left(\frac{H}{H_0}\right)^{3\alpha} = \left(\frac{65}{35}\right)^{3 \times 0.2} = 1.45$$

The power in the wind at the top tip of the rotor is 45% higher than it is when the tip reaches its lowest point.

---

Example 6.6 illustrates an important point about the variation in windspeed and power across the face of a spinning rotor. For large machines, when a blade

is at its high point, it can be exposed to much higher wind forces than when it is at the bottom of its arc. This variation in stress as the blade moves through a complete revolution is compounded by the impact of the tower itself on wind-speed—especially for downwind machines, which have a significant amount of wind “shadowing” as the blades pass behind the tower. The resulting flexing of a blade can increase the noise generated by the wind turbine and may contribute to blade fatigue, which can ultimately cause blade failure.

## 6.5 MAXIMUM ROTOR EFFICIENCY

It is interesting to note that a number of energy technologies have certain fundamental constraints that restrict the maximum possible conversion efficiency from one form of energy to another. For heat engines, it is the Carnot efficiency that limits the maximum work that can be obtained from an engine working between a hot and a cold reservoir. For photovoltaics, we will see that it is the band gap of the material that limits the conversion efficiency from sunlight into electrical energy. For fuel cells, it is the Gibbs free energy that limits the energy conversion from chemical to electrical forms. And now, we will explore the constraint that limits the ability of a wind turbine to convert kinetic energy in the wind to mechanical power.

The original derivation for the maximum power that a turbine can extract from the wind is credited to a German physicist, Albert Betz, who first formulated the relationship in 1919. The analysis begins by imagining what must happen to the wind as it passes through a wind turbine. As shown in Fig. 6.9, wind approaching from the left is slowed down as a portion of its kinetic energy is extracted by the turbine. The wind leaving the turbine has a lower velocity and its pressure is reduced, causing the air to expand downwind of the machine. An envelope drawn around the air mass that passes through the turbine forms what is called a *stream tube*, as suggested in the figure.

So why can't the turbine extract all of the kinetic energy in the wind? If it did, the air would have to come to a complete stop behind the turbine, which, with nowhere to go, would prevent any more of the wind to pass through the rotor. The downwind velocity, therefore, cannot be zero. And, it makes no sense for the downwind velocity to be the same as the upwind speed since that would mean the turbine extracted no energy at all from the wind. That suggests that there must be some ideal slowing of the wind that will result in maximum power extracted by the turbine. What Betz showed was that an ideal wind turbine would slow the wind to one-third of its original speed.

In Fig. 6.9, the upwind velocity of the undisturbed wind is  $v$ , the velocity of the wind through the plane of the rotor blades is  $v_b$ , and the downwind velocity is  $v_d$ . The mass flow rate of air within the stream tube is everywhere the same, call it  $\dot{m}$ . The power extracted by the blades  $P_b$  is equal to the difference in kinetic energy between the upwind and downwind air flows:

$$P_b = \frac{1}{2}\dot{m}(v^2 - v_d^2) \quad (6.18)$$

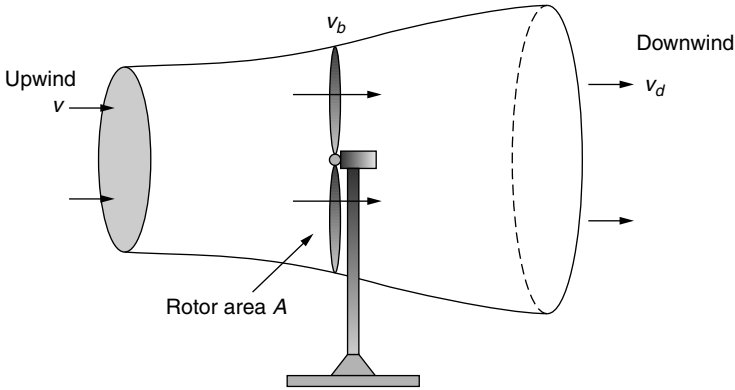

**Figure 6.9** Approaching wind slows and expands as a portion of its kinetic energy is extracted by the wind turbine, forming the stream tube shown.

The easiest spot to determine mass flow rate  $\dot{m}$  is at the plane of the rotor where we know the cross-sectional area is just the swept area of the rotor  $A$ . The mass flow rate is thus

$$\dot{m} = \rho A v_b \tag{6.19}$$

If we now make the assumption that the velocity of the wind through the plane of the rotor is just the average of the upwind and downwind speeds (Betz’s derivation actually does not depend on this assumption), then we can write

$$P_b = \frac{1}{2} \rho A \left( \frac{v + v_d}{2} \right) (v^2 - v_d^2) \tag{6.20}$$

To help keep the algebra simple, let us define the ratio of downstream to upstream windspeed to be  $\lambda$ :

$$\lambda = \left( \frac{v_d}{v} \right) \tag{6.21}$$

Substituting (6.21) into (6.20) gives

$$P_b = \frac{1}{2} \rho A \left( \frac{v + \lambda v}{2} \right) (v^2 - \lambda^2 v^2) = \underbrace{\frac{1}{2} \rho A v^3}_{\text{Power in the wind}} \cdot \underbrace{\left[ \frac{1}{2} (1 + \lambda)(1 - \lambda^2) \right]}_{\text{Fraction extracted}} \tag{6.22}$$

Equation (6.22) shows us that the power extracted from the wind is equal to the upstream power in the wind multiplied by the quantity in brackets. The quantity in the brackets is therefore the fraction of the wind’s power that is extracted by the blades; that is, it is the efficiency of the rotor, usually designated as  $C_p$ .

$$\text{Rotor efficiency} = C_p = \frac{1}{2} (1 + \lambda)(1 - \lambda^2) \tag{6.23}$$

So our fundamental relationship for the power delivered by the rotor becomes

$$P_b = \frac{1}{2}\rho Av^3 \cdot C_p \quad (6.24)$$

To find the maximum possible rotor efficiency, we simply take the derivative of (6.23) with respect to  $\lambda$  and set it equal to zero:

$$\begin{aligned} \frac{dC_p}{d\lambda} &= \frac{1}{2}[(1 + \lambda)(-2\lambda) + (1 - \lambda^2)] = 0 \\ &= \frac{1}{2}[(1 + \lambda)(-2\lambda) + (1 + \lambda)(1 - \lambda)] = \frac{1}{2}(1 + \lambda)(1 - 3\lambda) = 0 \end{aligned}$$

which has solution

$$\lambda = \frac{v_d}{v} = \frac{1}{3} \quad (6.25)$$

In other words, the blade efficiency will be a maximum if it slows the wind to one-third of its undisturbed, upstream velocity.

If we now substitute  $\lambda = 1/3$  into the equation for rotor efficiency (6.23), we find that the theoretical maximum blade efficiency is

$$\text{Maximum rotor efficiency} = \frac{1}{2} \left(1 + \frac{1}{3}\right) \left(1 - \frac{1}{3^2}\right) = \frac{16}{27} = 0.593 = 59.3\% \quad (6.26)$$

This conclusion, that the maximum theoretical efficiency of a rotor is 59.3%, is called the *Betz efficiency* or, sometimes, *Betz' law*. A plot of (6.22), showing this maximum occurring when the wind is slowed to one-third its upstream rate, is shown in Fig. 6.10.

The obvious question is, how close to the Betz limit for rotor efficiency of 59.3 percent are modern wind turbine blades? Under the best operating conditions, they can approach 80 percent of that limit, which puts them in the range of about 45 to 50 percent efficiency in converting the power in the wind into the power of a rotating generator shaft.

For a given windspeed, rotor efficiency is a function of the rate at which the rotor turns. If the rotor turns too slowly, the efficiency drops off since the blades are letting too much wind pass by unaffected. If the rotor turns too fast, efficiency is reduced as the turbulence caused by one blade increasingly affects the blade that follows. The usual way to illustrate rotor efficiency is to present it as a function of its *tip-speed ratio* (TSR). The tip-speed-ratio is the speed at which the outer tip of the blade is moving divided by the windspeed:

$$\text{Tip-Speed-Ratio (TSR)} = \frac{\text{Rotor tip speed}}{\text{Wind speed}} = \frac{\text{rpm} \times \pi D}{60 v} \quad (6.27)$$

where rpm is the rotor speed, revolutions per minute;  $D$  is the rotor diameter (m); and  $v$  is the wind speed (m/s) upwind of the turbine.

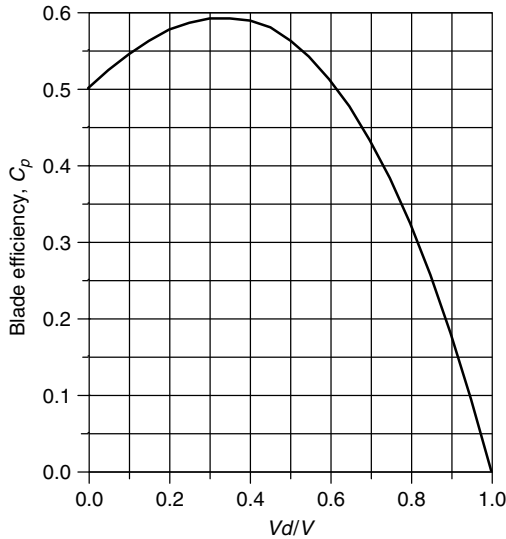

**Figure 6.10** The blade efficiency reaches a maximum when the wind is slowed to one-third of its upstream value.

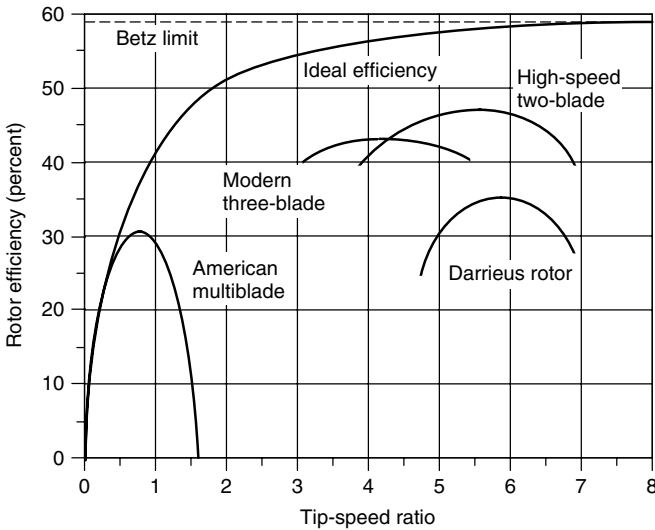

**Figure 6.11** Rotors with fewer blades reach their optimum efficiency at higher rotational speeds.

A plot of typical efficiency for various rotor types versus TSR is given in Fig. 6.11. The American multiblade spins relatively slowly, with an optimal TSR of less than 1 and maximum efficiency just over 30%. The two- and three-blade rotors spin much faster, with optimum TSR in the 4–6 range and maximum

efficiencies of roughly 40–50%. Also shown is a line corresponding to an “ideal efficiency,” which approaches the Betz limit as the rotor speed increases. The curvature in the maximum efficiency line reflects the fact that a slowly turning rotor does not intercept all of the wind, which reduces the maximum possible efficiency to something below the Betz limit.

**Example 6.7 How Fast Does a Big Wind Turbine Turn?** A 40-m, three-bladed wind turbine produces 600 kW at a windspeed of 14 m/s. Air density is the standard 1.225 kg/m<sup>3</sup>. Under these conditions,

- a. At what rpm does the rotor turn when it operates with a TSR of 4.0?
- b. What is the tip speed of the rotor?
- c. If the generator needs to turn at 1800 rpm, what gear ratio is needed to match the rotor speed to the generator speed?
- d. What is the efficiency of the complete wind turbine (blades, gear box, generator) under these conditions?

**Solution**

- a. Using (6.27),

$$\text{rpm} = \frac{\text{TSR} \times 60 v}{\pi D} = \frac{4 \times 60 \text{ s/min} \times 14 \text{ m/s}}{40\pi \text{ m/rev}} = 26.7 \text{ rev/min}$$

That’s about 2.2 seconds per revolution . . . pretty slow!

- b. The tip of each blade is moving at

$$\text{Tip speed} = \frac{26.7 \text{ rev/min} \times \pi 40 \text{ m/rev}}{60 \text{ s/min}} = 55.9 \text{ m/s}$$

Notice that even though 2.2 s/rev sounds slow; the tip of the blade is moving at a rapid 55.9 m/s, or 125 mph.

- c. If the generator needs to spin at 1800 rpm, then the gear box in the nacelle must increase the rotor shaft speed by a factor of

$$\text{Gear ratio} = \frac{\text{Generator rpm}}{\text{Rotor rpm}} = \frac{1800}{26.7} = 67.4$$

- d. From (6.4) the power in the wind is

$$P_w = \frac{1}{2} \rho A v_w^3 = \frac{1}{2} \times 1.225 \times \frac{\pi}{4} \times 40^2 \times 14^3 = 2112 \text{ kW}$$

so the overall efficiency of the wind turbine, from wind to electricity, is

$$\text{Overall efficiency} = \frac{600 \text{ kW}}{2112 \text{ kW}} = 0.284 = 28.4\%$$

Notice that if the rotor itself is about 43% efficient, as Fig. 6.11 suggests, then the efficiency of the gear box times the efficiency of the generator would be about 66% ( $43\% \times 66\% = 28.4\%$ ).

---

The answers derived in the above example are fairly typical for large wind turbines. That is, a large turbine will spin at about 20–30 rpm; the gear box will speed that up by roughly a factor of 50–70; and the overall efficiency of the machine is usually in the vicinity of 25–30%. In later sections of the chapter, we will explore these factors more carefully.

## 6.6 WIND TURBINE GENERATORS

The function of the blades is to convert kinetic energy in the wind into rotating shaft power to spin a generator that produces electric power. Generators consist of a rotor that spins inside of a stationary housing called a stator. Electricity is created when conductors move through a magnetic field, cutting lines of flux and generating voltage and current. While small, battery-charging wind turbines use dc generators, grid-connected machines use ac generators as described in the following sections.

### 6.6.1 Synchronous Generators

In Chapter 3, the operation of synchronous generators, which produce almost all of the electric power in the world, were described. Synchronous generators are forced to spin at a precise rotational speed determined by the number of poles and the frequency needed for the power lines. Their magnetic fields are created on their rotors. While very small synchronous generators can create the needed magnetic field with a permanent magnet rotor, almost all wind turbines that use synchronous generators create the field by running direct current through windings around the rotor core.

The fact that synchronous generator rotors need dc current for their field windings creates two complications. First, dc has to be provided, which usually means that a rectifying circuit, called the *exciter*, is needed to convert ac from the grid into dc for the rotor. Second, this dc current needs to make it onto the spinning rotor, which means that slip rings on the rotor shaft are needed, along with brushes that press against them. Replacing brushes and cleaning up slip rings adds to the maintenance needed by these synchronous generators. Figure 6.12 shows the basic system for a wind turbine with a synchronous generator, including

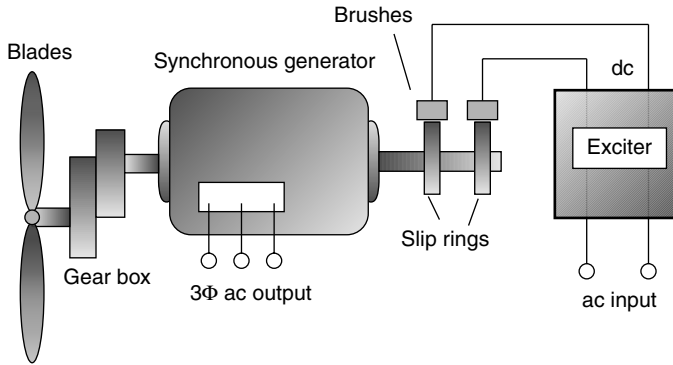

**Figure 6.12** A three-phase synchronous generator needs dc for the rotor windings, which usually means that slip rings and brushes are needed to transfer that current to the rotor from the exciter.

a reminder that the generator and blades are connected through a gear box to match the speeds required of each.

### 6.6.2 The Asynchronous Induction Generator

Most of the world’s wind turbines use induction generators rather than the synchronous machines just described. In contrast to a synchronous generator (or motor), induction machines do not turn at a fixed speed, so they are often described as *asynchronous* generators. While induction generators are uncommon in power systems other than wind turbines, their counterpart, induction motors, are the most prevalent motors around—using almost one-third of all the electricity generated worldwide. In fact, an induction machine can act as a motor or generator, depending on whether shaft power is being put into the machine (generator) or taken out (motor). Both modes of operation, as a motor during start-up and as a generator when the wind picks up, take place in wind turbines with induction generators. As a motor, the rotor spins a little slower than the synchronous speed established by its field windings, and in its attempts to “catch up” it delivers power to its rotating shaft. As a generator, the turbine blades spin the rotor a little faster than the synchronous speed and energy is delivered into its stationary field windings.

The key advantage of asynchronous induction generators is that their rotors do not require the exciter, brushes, and slip rings that are needed by most synchronous generators. They do this by creating the necessary magnetic field in the stator rather than the rotor. This means that they are less complicated and less expensive and require less maintenance. Induction generators are also a little more forgiving in terms of stresses to the mechanical components of the wind turbine during gusty wind conditions.



**Rotating Magnetic Field.** To understand how an induction generator or motor works, we need to introduce the concept of a rotating magnetic field. Begin by imagining coils imbedded in the stator of a three-phase generator as shown in Fig. 6.13. These coils consist of copper conductors running the length of the stator, looping around, and coming back up the other side. We will adopt the convention that positive current in any phase means that current flows from the unprimed letter to the primed one (e.g., positive  $i_A$  means that current flows from  $A$  to  $A'$ ). When current in a phase is positive, the resulting magnetic field is drawn with a bold arrow; when it is negative, a dashed arrow is used. And remember the arrow symbolism: a “+” at the end of a wire means current flow into the page, while a dot means current flow out of the page.

Now, consider the magnetic fields that result from three-phase currents flowing in the stator. In Fig. 6.14a, the clock is stopped at  $\omega t = 0$ , at which point  $i_A$  reaches its maximum positive value, and  $i_B$  and  $i_C$  are both negative and equal in magnitude. The magnetic flux for each of the three currents is shown, the sum of which is a flux arrow that points vertically downward. A while later, let us stop the clock at  $\omega t = \pi/3 = 60^\circ$ . Now  $i_A = i_B$  and both are positive, while  $i_C$  is now its maximum negative value, as shown in Fig. 6.14b. The resultant sum of the fluxes has now rotated  $60^\circ$  in the clockwise direction. We could continue this exercise for increasing values of  $\omega t$  and we would see the resultant flux continuing to rotate around. This is an important concept for the inductance generator: With three-phase currents flowing in the stator, a rotating magnetic field is created inside the generator. The field rotates at the synchronous speed  $N_s$  determined by the frequency of the currents  $f$  and the number of poles  $p$ . That is,  $N_s = 120f/p$ , as was the case for a synchronous generator.

**The Squirrel Cage Rotor.** A three-phase induction generator must be supplied with three-phase ac currents, which flow through its stator, establishing the rotating magnetic field described above. The rotor of many induction generators (and motors) consists of a number of copper or aluminum bars shorted together at their ends, forming a cage not unlike one you might have to give your pet rodent some

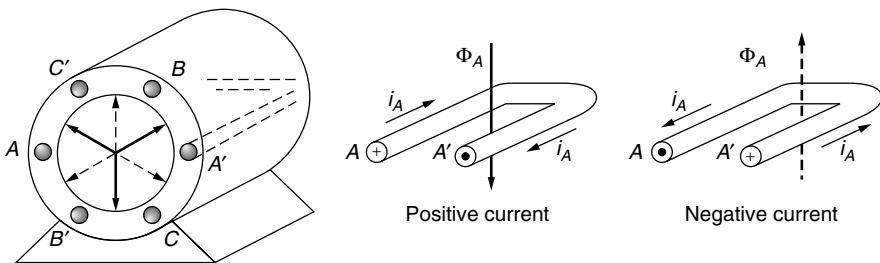

**Figure 6.13** Nomenclature for the stator of an inductance generator. Positive current flow from  $A$  to  $A'$  results in magnetic flux  $\Phi_A$  represented by a bold arrow pointing downward. Negative current (from  $A'$  to  $A$ ) results in magnetic flux represented by a dotted arrow pointing up.

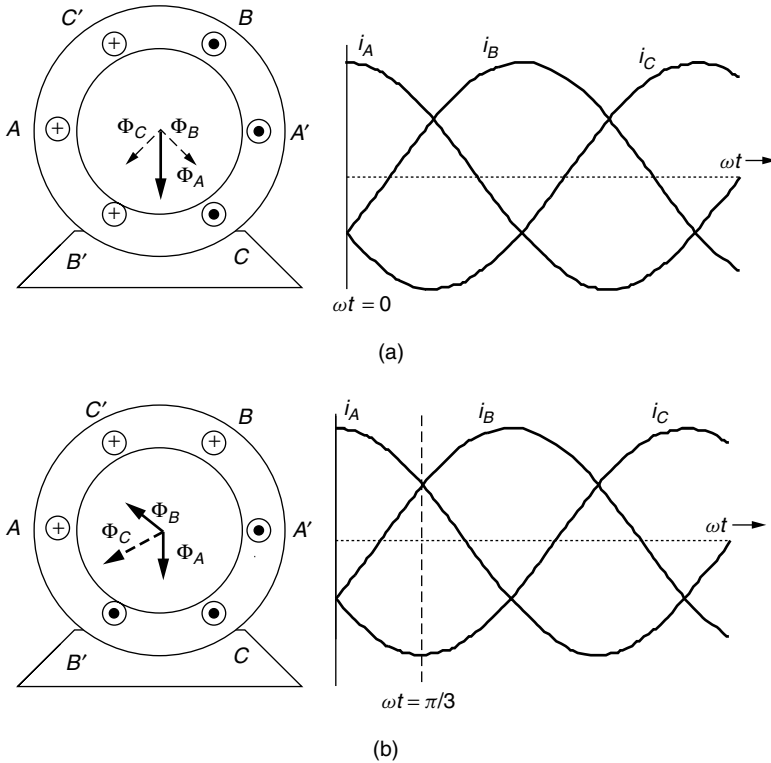

**Figure 6.14** (a) At  $\omega t = 0$ ,  $i_A$  is a positive maximum while  $i_B$  and  $i_C$  are both negative and equal to each other. The resulting sum of the magnetic fluxes points straight down; (b) at  $\omega t = \pi/3$ , the magnetic flux vectors appear to have rotated clockwise by  $60^\circ$ .

exercise. They used to be called “squirrel” cage rotors, but now they are just cage rotors. The cage is then imbedded in an iron core consisting of thin (0.5 mm) insulated steel laminations. The laminations help control eddy current losses (see Section 1.8.2). Figure 6.15 shows the basic relationship between stator and rotor, which can be thought of as a pair of magnets (in the stator) spinning around the cage (rotor).

To understand how the rotating stator field interacts with the cage rotor, consider Fig. 6.16a. The rotating stator field is shown moving toward the right, while the conductor in the cage rotor is stationary. Looked at another way, the stator field can be thought to be stationary and, relative to it, the conductor appears to be moving to the left, cutting lines of magnetic flux as shown in Fig. 6.16b. Faraday’s law of electromagnetic induction (see Section 1.6.1) says that whenever a conductor cuts flux lines, an emf will develop along the conductor and, if allowed to, current will flow. In fact, the cage rotor has thick conductor bars with very little resistance, so lots of current can flow easily. That rotor current, labeled  $i_R$  in Fig. 6.16b, will create its own magnetic field, which wraps around

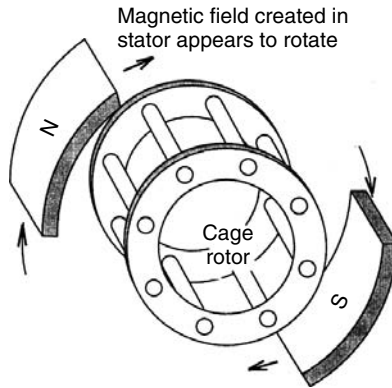

**Figure 6.15** A cage rotor consisting of thick, conducting bars shorted at their ends, around which circulates a rotating magnetic field.

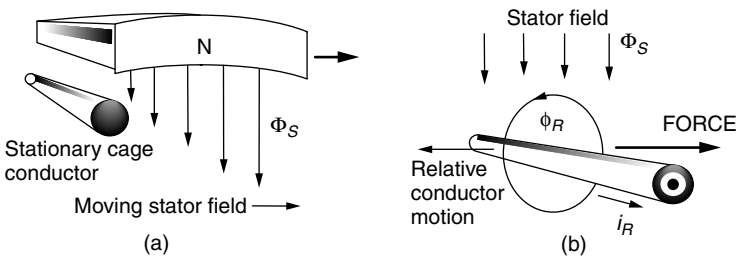

**Figure 6.16** In (a) the stator field moves toward the right while the cage rotor conductor is stationary. As shown in (b), this is equivalent to the stator field being stationary while the conductor moves to the left, cutting lines of flux. The conductor then experiences a force that tries to make the rotor want to catch up to the stator's rotating magnetic field.

the conductor. The rotor's magnetic field then interacts with the stator's magnetic field, producing a force that attempts to drive the cage conductor to the right. In other words, the rotor wants to spin in the same direction that the rotating stator field is revolving—in this case, clockwise.

**The Inductance Machine as a Motor.** Since it is easier to understand an induction motor than an induction generator, we'll start with it. The rotating magnetic field in the stator of the inductance machine causes the rotor to spin in the same direction. That is, the machine is a motor—an induction motor. Notice that there are no electrical connections to the rotor; no slip rings or brushes are required. As the rotor approaches the synchronous speed of the rotating magnetic field, the relative motion between them gets smaller and smaller and less and less force is exerted on the rotor. If the rotor could move at the synchronous speed, there would be no relative motion, no current induced in the cage conductors, and no force developed to keep the rotor going. Since there will always be friction to

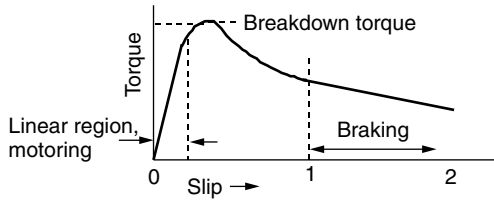

**Figure 6.17** The torque–slip curve for an inductance motor.

overcome, the induction machine operating as a motor spins at a rate somewhat slower than the synchronous speed determined by the stator. This difference in speed is called slip, which is defined mathematically as

$$s = \frac{N_S - N_R}{N_S} = 1 - \frac{N_R}{N_S} \quad (6.28)$$

where  $s$  is the rotor slip,  $N_S$  is the no-load synchronous speed  $= 120f/p$  rpm, where  $f$  is frequency and  $p$  is poles, and  $N_R$  is the rotor speed.

As the load on the motor increases, the rotor slows down, increasing the slip, until enough torque is generated to meet the demand. In fact, for most induction motors, slip increases quite linearly with torque within the usual range of allowable slip. There comes a point, however, when the load exceeds what is called the “breakdown torque” and increasing the slip no longer satisfies the load and the rotor will stop (Fig. 6.17). If the rotor is forced to rotate in the opposite direction to the stator field, the inductance machine operates as a brake.

---

**Example 6.8 Slip for an induction motor** A 60-Hz, four-pole induction motor reaches its rated power when the slip is 4%. What is the rotor speed at rated power?

The no-load synchronous speed of a 60-Hz, four-pole motor is

$$N_s = \frac{120f}{p} = \frac{120 \times 60}{4} = 1800 \text{ rpm}$$

From (6.28) at a slip of 4%, the rotor speed would be

$$N_R = (1 - s)N_S = (1 - 0.04) \cdot 1800 = 1728 \text{ rpm}$$

---

**The Inductance Machine as a Generator.** When the stator is provided with three-phase excitation current and the shaft is connected to a wind turbine and

gearbox, the machine will start operation by motoring up toward its synchronous speed. When the windspeed is sufficient to force the generator shaft to exceed synchronous speed, the induction machine automatically becomes a three-phase generator delivering electrical power back to its stator windings. But where does the three-phase magnetization current come from that started this whole process? If it is grid-connected, the power lines provide that current. It is possible, however, to have an induction generator provide its own ac excitation current by incorporating external capacitors, which allows for power generation without the grid.

The basic concept for a self-excited generator is to create a resonance condition between the inherent inductance of the field windings in the stator and the external capacitors that have been added. A capacitor and an inductor connected in parallel form the basis for electronic oscillators; that is, they have a resonant frequency at which they will spontaneously oscillate if given just a nudge in that direction. That nudge is provided by a remnant magnetic field in the rotor. The oscillation frequency, and hence the rotor excitation frequency, depends on the size of the external capacitors, which provides one way to control wind turbine speed. In Fig. 6.18, a single-phase, self-excited, induction generator is diagrammed showing the external capacitance.

So how fast does an inductance generator spin? The same slip factor definition as was used for inductance motors applies [Eq. (6.28)], except that now the slip will be a negative number since the rotor spins faster than synchronous speed. For grid-connected inductance generators, the slip is normally no more than about 1%. This means, for example, that a two-pole, 60-Hz generator with synchronous speed 3600 rpm will turn at about

$$N_R = (1 - s)N_S = [1 - (-0.01)] \cdot 3600 = 3636 \text{ rpm}$$

An added bonus with induction generators is they can cushion the shocks caused by fast changes in wind speed. When the windspeed suddenly changes, the slip increases or decreases accordingly, which helps absorb the shock to the wind turbine mechanical equipment.

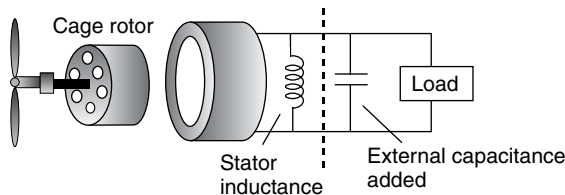

**Figure 6.18** A self-excited inductance generator. External capacitors resonate with the stator inductance causing oscillation at a particular frequency. Only a single phase is shown.

## 6.7 SPEED CONTROL FOR MAXIMUM POWER

In this section we will explore the role that the gear box and generator have with regard to the rotational speed of the rotor and the energy delivered by the machine. Later, we will describe the need for speed control of rotor blades to be able to shed wind to prevent overloading the turbine's electrical components in highwinds.

### 6.7.1 Importance of Variable Rotor Speeds

There are other reasons besides shedding high-speed winds that rotor speed control is an important design task. Recall Fig. 6.11, in which rotor efficiency  $C_p$  was shown to depend on the tip-speed ratio, TSR. Modern wind turbines operate best when their TSR is in the range of around 4–6, meaning that the tip of a blade is moving 4–6-times the wind speed. Ideally, then, for maximum efficiency, turbine blades should change their speed as the windspeed changes. Figure 6.19 illustrates this point by showing an example of blade efficiency versus wind speed with three discrete steps in rotor rpm as a parameter. Unless the rotor speed can be adjusted, blade efficiency  $C_p$  changes as wind speed changes. It is interesting to note, however, that  $C_p$  is relatively flat near its peaks so that continuous adjustment of rpm is only modestly better than having just a few discrete rpm steps available.

While Fig. 6.19 shows the impact of rotor speed on blade efficiency, what is more important is electric power delivered by the wind turbine. Figure 6.20

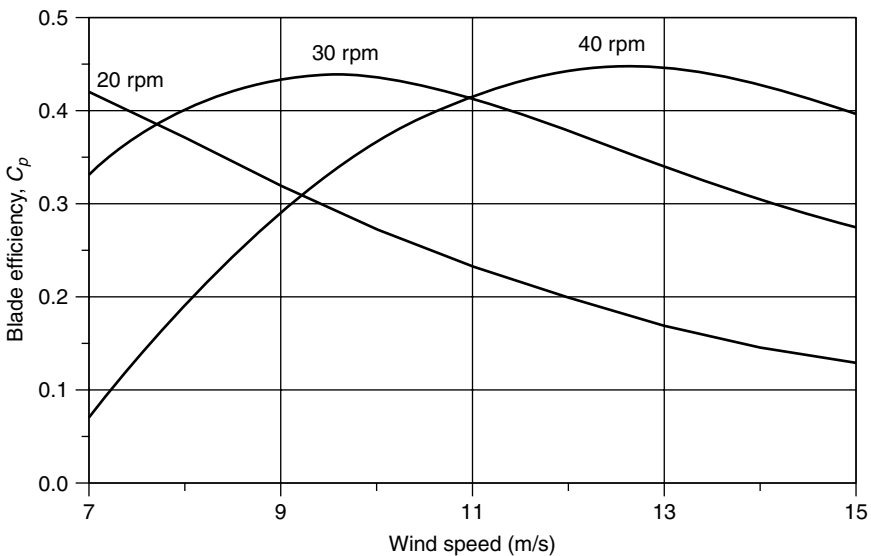

**Figure 6.19** Blade efficiency is improved if its rotation speed changes with changing wind speed. In this figure, three discrete speeds are shown for a hypothetical rotor.

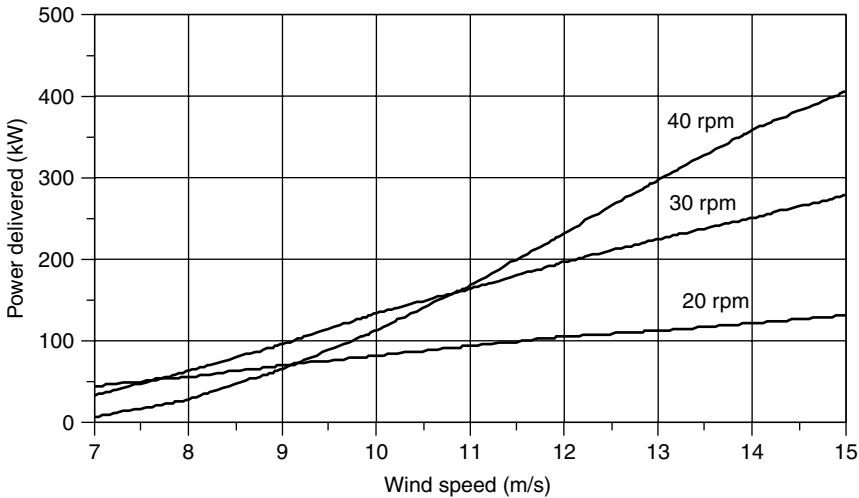

**Figure 6.20** Example of the impact that a three-step rotational speed adjustment has on delivered power. For winds below 7.5 m/s, 20 rpm is best; between 7.5 and 11 m/s, 30 rpm is best; and above 11 m/s, 40 rpm is best.

shows the impact of varying rotor speed from 20 to 30 to 40 rpm for a 30-m rotor with efficiency given in Fig. 6.19, along with an assumed gear and generator efficiency of 70%.

While blade efficiency benefits from adjustments in speed as illustrated in Figs. 6.19 and 6.20, the generator may need to spin at a fixed rate in order to deliver current and voltage in phase with the grid that it is feeding. So, for grid-connected turbines, the challenge is to design machines that can somehow accommodate variable rotor speed and somewhat fixed generator speed—or at least attempt to do so. If the wind turbine is not grid-connected, the generator electrical output can be allowed to vary in frequency (usually it is converted to dc), so this dilemma isn't a problem.

### 6.7.2 Pole-Changing Induction Generators

Induction generators spin at a frequency that is largely controlled by the number of poles. A two-pole, 60-Hz generator rotates at very close to 3600 rpm; with four poles it rotates at close to 1800 rpm; and so on. If we could change the number of poles, we could allow the wind turbine to have several operating speeds, approximating the performance shown in Figs. 6.19 and 6.20. A key to this approach is that as far as the rotor is concerned, the number of poles in the stator of an induction generator is irrelevant. That is, the stator can have external connections that switch the number of poles from one value to another without needing any change in the rotor. This approach is common in household appliance motors such as those used in washing machines and exhaust fans to give two- or three-speed operation.

### 6.7.3 Multiple Gearboxes

Some wind turbines have two gearboxes with separate generators attached to each, giving a low-wind-speed gear ratio and generator plus a high-wind-speed gear ratio and generator.

### 6.7.4 Variable-Slip Induction Generators

A normal induction generator maintains its speed within about 1% of the synchronous speed. As it turns out, the slip in such generators is a function of the dc resistance in the rotor conductors. By purposely adding variable resistance to the rotor, the amount of slip can range up to around 10% or so, which would mean, for example, that a four-pole, 1800-rpm machine could operate anywhere from about 1800 to 2000 rpm. One way to provide this capability is to have adjustable resistors external to the generator, but the trade-off is that now an electrical connection is needed between the rotor and resistors. That can mean abandoning the elegant cage rotor concept and instead using a wound rotor with slip rings and brushes similar to what a synchronous generator has. And that means more maintenance will be required.

Another way to provide variable resistance for the rotor is to physically mount the resistors and the electronics that are needed to control them on the rotor itself. But then you need some way to send signals to the rotor telling it how much slip to provide. In one system, called Opti Slip<sup>®</sup>, an optical fiber link to the rotor is used for this communication.

### 6.7.5 Indirect Grid Connection Systems

In this approach, the wind turbine is allowed to spin at whatever speed that is needed to deliver the maximum amount of power. When attached to a synchronous or induction generator, the electrical output will have variable frequency depending on whatever speed the wind turbine happens to have at the moment. This means that the generator cannot be directly connected to the utility grid, which of course requires fixed 50- or 60-Hz current.

Figure 6.21 shows the basic concept of these indirect systems. Variable-frequency ac from the generator is rectified and converted into dc using high-power transistors. This dc is then sent to an inverter that converts it back to ac, but this time with a steady 50- or 60-Hz frequency. The raw output of an inverter is pretty choppy and needs to be filtered to smooth it. As described in Chapter 2, any time ac is converted to dc and back again, there is the potential for harmonics to be created, so one of the challenges associated with these variable-speed, indirect wind turbine systems is maintaining acceptable power quality.

In addition to higher annual energy production, variable-speed wind turbines have an advantage of greatly minimizing the wear and tear on the whole system caused by rapidly changing wind speeds. When gusts of wind hit the turbine, rather than having a burst of torque hit the blades, drive shaft, and gearbox,



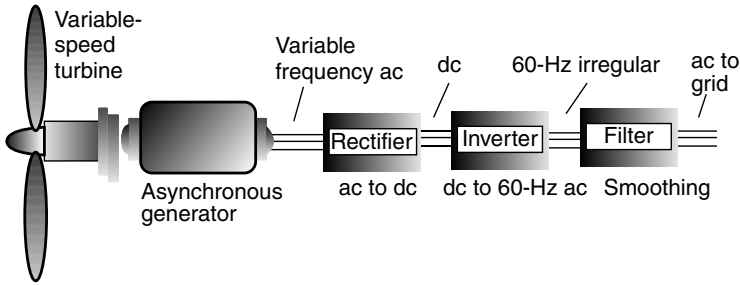

**Figure 6.21** Variable-frequency output of the asynchronous generator is rectified, inverted, and filtered to produce acceptable 60-Hz power to the grid.

the blades merely speed up, thereby reducing those system stresses. In addition, some of that extra energy in those gusts can be captured and delivered.

## 6.8 AVERAGE POWER IN THE WIND

Having presented the equations for *power* in the wind and described the essential components of a wind turbine system, it is time to put the two together to determine how much *energy* might be expected from a wind turbine in various wind regimes,

The cubic relationship between power in the wind and wind velocity tells us that we cannot determine the average power in the wind by simply substituting average windspeed into (6.4). We saw this in Example 6.1. We can begin to explore this important nonlinear characteristic of wind by rewriting (6.4) in terms of average values:

$$P_{\text{avg}} = \left(\frac{1}{2}\rho Av^3\right)_{\text{avg}} = \frac{1}{2}\rho A(v^3)_{\text{avg}} \quad (6.29)$$

In other words, we need to find the average value of the cube of velocity. To do so will require that we introduce some statistics.

### 6.8.1 Discrete Wind Histogram

We are going to have to work with the mathematics of probability and statistics, which may be new territory for some. To help motivate our introduction to this material, we will begin with some simple concepts involving discrete functions involving windspeeds, and then we can move on to more generalized continuous functions.

What do we mean by the *average* of some quantity? Suppose, for example, we collect some wind data at a site and then want to know how to figure out the

average windspeed during the measurement time. The average wind speed can be thought of as the total meters, kilometers, or miles of wind that have blown past the site, divided by the total time that it took to do so. Suppose, for example, that during a 10-h period, there were 3 h of no wind, 3 h at 5 mph, and 4 h at 10 mph. The average windspeed would be

$$\begin{aligned}
 v_{\text{avg}} &= \frac{\text{Miles of wind}}{\text{Total hours}} = \frac{3 \text{ h} \cdot 0 \text{ mile/hr} + 3 \text{ h} \cdot 5 \text{ mile/h} + 4 \text{ h} \cdot 10 \text{ mile/h}}{3 + 3 + 4 \text{ h}} \\
 &= \frac{55 \text{ mile}}{10 \text{ h}} = 5.5 \text{ mph}
 \end{aligned}
 \tag{6.30}$$

By regrouping some of the terms in (6.30), we could also think of this as having no wind 30% of the time, 5 mph for 30% of the time, and 10 mph 40% of the time:

$$v_{\text{avg}} = \left(\frac{3 \text{ h}}{10 \text{ h}}\right) \times 0 \text{ mph} + \left(\frac{3 \text{ h}}{10 \text{ h}}\right) \times 5 \text{ mph} + \left(\frac{4 \text{ h}}{10 \text{ h}}\right) \times 10 \text{ mph} = 5.5 \text{ mph}
 \tag{6.31}$$

We could write (6.30) and (6.31) in a more general way as

$$v_{\text{avg}} = \frac{\sum_i [v_i \cdot (\text{hours @ } v_i)]}{\sum \text{hours}} = \sum_i [v_i \cdot (\text{fraction of hours @ } v_i)]
 \tag{6.32}$$

Finally, if those winds were typical, we could say that the probability that there is no wind is 0.3, the probability that it is blowing 5 mph is 0.3, and the probability that it is 10 mph is 0.4. This lets us describe the average value in probabilistic terms:

$$v_{\text{avg}} = \sum_i [v_i \cdot \text{probability}(v = v_i)]
 \tag{6.33}$$

We know from (6.29) that the quantity of interest in determining average power in the wind is not the average value of  $v$ , but the average value of  $v^3$ . The averaging process is exactly the same as our simple example above, yielding the following:

$$(v^3)_{\text{avg}} = \frac{\sum_i [v_i^3 \cdot (\text{hours @ } v_i)]}{\sum \text{hours}} = \sum_i [v_i^3 \cdot (\text{fraction of hours @ } v_i)]
 \tag{6.34}$$

Or, in probabilistic terms,

$$(v^3)_{\text{avg}} = \sum_i [v_i^3 \cdot \text{probability}(v = v_i)]
 \tag{6.35}$$

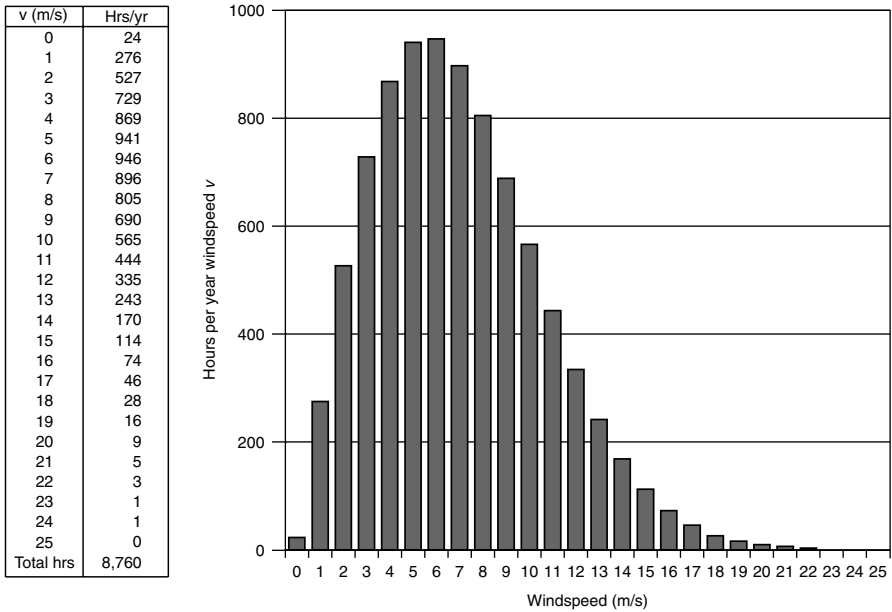

**Figure 6.22** An example of site data and the resulting wind histogram showing hours that the wind blows at each windspeed.

Begin by imagining that we have an anemometer that accumulates site data on hours per year of wind blowing at 1 m/s (0.5 to 1.5 m/s), at 2 m/s (1.5 to 2.5 m/s), and so on. An example table of such data, along with a histogram, is shown in Fig. 6.22.

---

**Example 6.9 Average Power in the Wind.** Using the data given in Fig. 6.22, find the average windspeed and the average power in the wind ( $W/m^2$ ). Assume the standard air density of  $1.225 \text{ kg/m}^3$ . Compare the result with that which would be obtained if the average power were miscalculated using just the average windspeed.

**Solution.** We need to set up a spreadsheet to determine average wind speed  $v$  and the average value of  $v^3$ . Let’s do a sample calculation of one line of a spreadsheet using the 805 h/yr at 8 m/s:

$$\text{Fraction of annual hours at 8 m/s} = \frac{805 \text{ h/yr}}{24 \text{ h/d} \times 365 \text{ d/yr}} = 0.0919$$

$$v_8 \cdot \text{Fraction of hours at 8 m/s} = 8 \text{ m/s} \times 0.0919 = 0.735$$

$$(v_8)^3 \cdot \text{Fraction of hours at 8 m/s} = 8^3 \times 0.0919 = 47.05$$

The rest of the spreadsheet to determine average wind power using (6.29) is as follows:

Wind Speed $v_i$ (m/s)	Hours @ $v_i$ per year	Fraction of Hours @ $v_i$	$v_i \times$ Fraction Hours @ $v_i$	$(v_i)^3$	$(v_i)^3 \times$ fraction Hours @ $v_i$
0	24	0.0027	0.000	0	0.00
1	276	0.0315	0.032	1	0.03
2	527	0.0602	0.120	8	0.48
3	729	0.0832	0.250	27	2.25
4	869	0.0992	0.397	64	6.35
5	941	0.1074	0.537	125	13.43
6	946	0.1080	0.648	216	23.33
7	896	0.1023	0.716	343	35.08
8	805	0.0919	0.735	512	47.05
9	690	0.0788	0.709	729	57.42
10	565	0.0645	0.645	1,000	64.50
11	444	0.0507	0.558	1,331	67.46
12	335	0.0382	0.459	1,728	66.08
13	243	0.0277	0.361	2,197	60.94
14	170	0.0194	0.272	2,744	53.25
15	114	0.0130	0.195	3,375	43.92
16	74	0.0084	0.135	4,096	34.60
17	46	0.0053	0.089	4,913	25.80
18	28	0.0032	0.058	5,832	18.64
19	16	0.0018	0.035	6,859	12.53
20	9	0.0010	0.021	8,000	8.22
21	5	0.0006	0.012	9,261	5.29
22	3	0.0003	0.008	10,648	3.65
23	1	0.0001	0.003	12,167	1.39
24	1	0.0001	0.003	13,824	1.58
25	0	0.0000	0.000	15,625	0.00
<b>Totals:</b>	8760	1.000	7.0		653.24

The average windspeed is

$$v_{\text{avg}} = \sum_i [v_i \cdot (\text{Fraction of hours @ } v_i)] = 7.0 \text{ m/s}$$

The average value of  $v^3$  is

$$(v^3)_{\text{avg}} = \sum_i [v_i^3 \cdot (\text{Fraction of hours @ } v_i)] = 653.24$$

The average power in the wind is

$$P_{\text{avg}} = \frac{1}{2}\rho(v^3)_{\text{avg}} = 0.5 \times 1.225 \times 653.24 = 400 \text{ W/m}^2$$

If we had miscalculated average power in the wind using the 7 m/s *average* windspeed, we would have found:

$$P_{\text{average(WRONG)}} = \frac{1}{2}\rho(v_{\text{avg}})^3 = 0.5 \times 1.225 \times 7.0^3 = 210 \text{ W/m}^2$$

In the above example, the ratio of the average wind power calculated correctly using  $(v^3)_{\text{avg}}$  to that found when the average velocity is (mis)used is  $400/210 = 1.9$ . That is, the correct answer is nearly twice as large as the power found when average windspeed is substituted into the fundamental wind power equation  $P = \frac{1}{2}\rho Av^3$ . In the next section we will see that this conclusion is always the case when certain probability characteristics for the wind are assumed.

### 6.8.2 Wind Power Probability Density Functions

The type of information displayed in the discrete windspeed histogram in Fig. 6.22 is very often presented as a continuous function, called a probability density function (p.d.f.). The defining features of a p.d.f., such as that shown in Fig. 6.23, are that the area under the curve is equal to unity, and the area under the curve

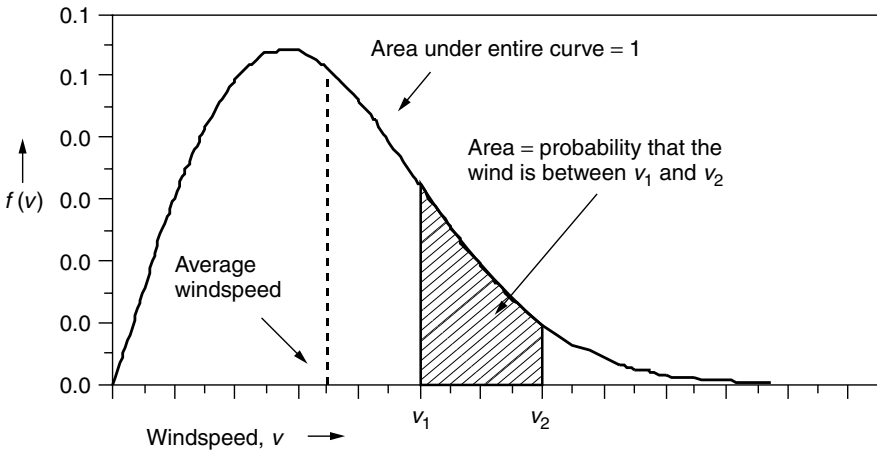

**Figure 6.23** A windspeed probability density function (p.d.f.).

between any two windspeeds equals the probability that the wind is between those two speeds.

Expressed mathematically,

$$f(v) = \text{windspeed probability density function}$$

$$\text{probability } (v_1 \leq v \leq v_2) = \int_{v_1}^{v_2} f(v) \, dv \tag{6.36}$$

$$\text{probability } (0 \leq v \leq \infty) = \int_0^{\infty} f(v) \, dv = 1 \tag{6.37}$$

If we want to know the number of hours per year that the wind blows between any two windspeeds, simply multiply (6.36) by 8760 hours per year:

$$\text{hours/yr } (v_1 \leq v \leq v_2) = 8760 \int_{v_1}^{v_2} f(v) \, dv \tag{6.38}$$

The average windspeed can be found using a p.d.f. in much the same manner as it was found for the discrete approach to wind analysis (6.33):

$$v_{\text{avg}} = \int_0^{\infty} v \cdot f(v) \, dv \tag{6.39}$$

The average value of the cube of velocity, also analogous to the discrete version in (6.35), is

$$(v^3)_{\text{avg}} = \int_0^{\infty} v^3 \cdot f(v) \, dv \tag{6.40}$$

### 6.8.3 Weibull and Rayleigh Statistics

A very general expression that is often used as the starting point for characterizing the statistics of windspeeds is called the *Weibull probability density function*:

$$f(v) = \frac{k}{c} \left(\frac{v}{c}\right)^{k-1} \exp\left[-\left(\frac{v}{c}\right)^k\right] \quad \text{Weibull p.d.f.} \tag{6.41}$$

where  $k$  is called the *shape parameter*, and  $c$  is called the *scale parameter*.

As the name implies, the shape parameter  $k$  changes the look of the p.d.f. For example, the Weibull p.d.f. with a fixed scale parameter ( $c = 8$ ) but varying shape parameters  $k$  is shown in Fig. 6.24. For  $k = 1$ , it looks like an exponential decay function; it would probably not be a good site for a wind turbine since most of the winds are at such low speeds. For  $k = 2$ , the wind blows fairly

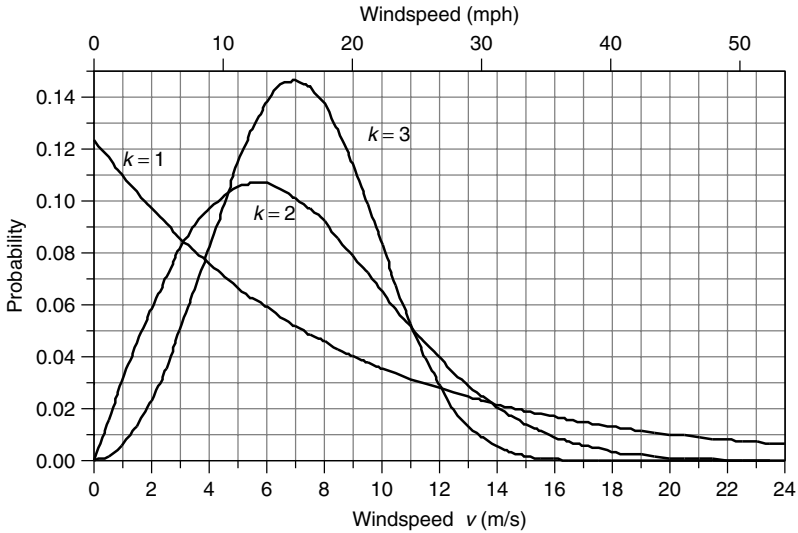

**Figure 6.24** Weibull probability density function with shape parameter  $k = 1, 2,$  and  $3$  (with scale parameter  $c = 8$ ).

consistently, but there are periods during which the winds blow much harder than the more typical speeds bunched near the peak of the p.d.f. For  $k = 3$ , the function resembles the familiar bell-shaped curve, and the site would be one where the winds are almost always blowing and doing so at a fairly constant speed, such as the trade winds do.

Of the three Weibull p.d.f.s in Fig. 6.24, intuition probably would lead us to think that the middle one, for which  $k = 2$ , is the most realistic for a likely wind turbine site; that is, it has winds that are mostly pretty strong, with periods of low wind and some really good high-speed winds as well. In fact, when little detail is known about the wind regime at a site, the usual starting point is to assume  $k = 2$ . When the shape parameter  $k$  is equal to 2, the p.d.f. is given its own name, the *Rayleigh* probability density function:

$$f(v) = \frac{2v}{c^2} \exp \left[ -\left(\frac{v}{c}\right)^2 \right] \quad \text{Rayleigh p.d.f.} \quad (6.42)$$

The impact of changing the scale parameter  $c$  for a Rayleigh p.d.f. is shown in Fig. 6.25. As can be seen, larger-scale factors shift the curve toward higher windspeeds. There is, in fact, a direct relationship between scaling factor  $c$  and average wind speed  $\bar{v}$ . Substituting the Rayleigh p.d.f. into (6.39) and referring to a table of standard integrals yield

$$\bar{v} = \int_0^\infty v \cdot f(v) dv = \int_0^\infty \frac{2v^2}{c^2} \exp \left[ -\left(\frac{v}{c}\right)^2 \right] = \frac{\sqrt{\pi}}{2} c \cong 0.886c \quad (6.43)$$

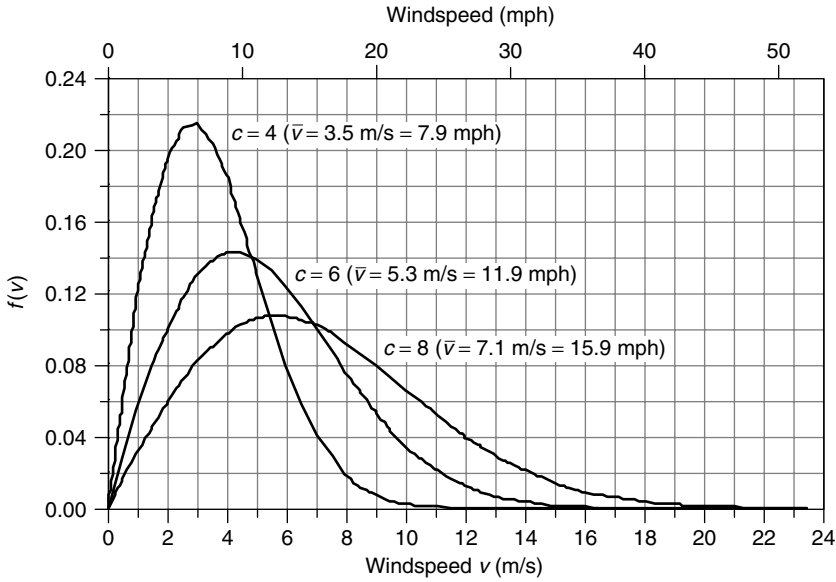

**Figure 6.25** The Rayleigh probability density function with varying scale parameter  $c$ . Higher scaling parameters correspond to higher average windspeeds.

Or, the other way around:

$$c = \frac{2}{\sqrt{\pi}} \bar{v} \cong 1.128 \bar{v} \tag{6.44}$$

Even though (6.44) was derived for Rayleigh statistics, it is quite accurate for a range of shape factors  $k$  from about 1.5 to 4 (Johnson, 1985). Substituting (6.44) into (6.42) gives us a more intuitive way to write the Rayleigh p.d.f. in terms of average windspeed  $\bar{v}$ :

$$f(v) = \frac{\pi v}{2\bar{v}^2} \exp \left[ -\frac{\pi}{4} \left( \frac{v}{\bar{v}} \right)^2 \right] \quad \text{Rayleigh} \tag{6.45}$$

**6.8.4 Average Power in the Wind with Rayleigh Statistics**

The starting point for wind prospecting is to gather enough site data to at least be able to estimate average windspeed. That can most easily be done with an anemometer (which spins at a rate proportional to the wind speed) that has a revolution counter calibrated to indicate miles of wind that passes. Dividing miles of wind by elapsed time gives an average wind speed. These “wind odometers” are modestly priced (about \$200 each) and simple to use. Coupling average windspeed with the assumption that the wind speed distribution follows Rayleigh statistics enables us to find the average power in the wind.



Substituting the Rayleigh p.d.f. (6.42) into (6.40) lets us find the average value of the cube of windspeed:

$$(v^3)_{\text{avg}} = \int_0^{\infty} v^3 \cdot f(v)dv = \int_0^{\infty} v^3 \cdot \frac{2v}{c^2} \exp\left[-\left(\frac{v}{c}\right)^2\right] dv = \frac{3}{4}c^3\sqrt{\pi} \quad (6.46)$$

Using (6.44) gives an alternative expression:

$$(v^3)_{\text{avg}} = \frac{3}{4}\sqrt{\pi} \left(\frac{2\bar{v}}{\sqrt{\pi}}\right)^3 = \frac{6}{\pi}\bar{v}^3 = 1.91 \bar{v}^3 \quad (6.47)$$

Equation (6.47) is very interesting and very useful. It says that if we assume Rayleigh statistics then the average of the cube of windspeed is just 1.91 times the average wind speed cubed. Therefore, assuming Rayleigh statistics, we can rewrite the fundamental relationship for average power in the wind as

$$\bar{P} = \frac{6}{\pi} \cdot \frac{1}{2} \rho A \bar{v}^3 \quad (\text{Rayleigh assumptions}) \quad (6.48)$$

That is, with Rayleigh statistics, *the average power in the wind is equal to the power found at the average windspeed multiplied by  $6/\pi$  or 1.91.*

**Example 6.10 Average Power in the Wind.** Estimate the average power in the wind at a height of 50 m when the windspeed at 10 m averages 6 m/s. Assume Rayleigh statistics, a standard friction coefficient  $\alpha = 1/7$ , and standard air density  $\rho = 1.225 \text{ kg/m}^3$ .

**Solution.** We first adjust the winds at 10 m to those expected at 50 m using (6.15):

$$\bar{v}_{50} = \bar{v}_{10} \left(\frac{H_{50}}{H_{10}}\right)^{\alpha} = 6 \cdot \left(\frac{50}{10}\right)^{1/7} = 7.55 \text{ m/s}$$

So, using (6.48), the average wind power density would be

$$\bar{P}_{50} = \frac{6}{\pi} \cdot \frac{1}{2} \rho \bar{v}^3 = \frac{6}{\pi} \cdot \frac{1}{2} \cdot 1.225 \cdot (7.55)^3 = 504 \text{ W/m}^2$$

We also could have found average power at 10 m and then adjust it to 50 m using (6.17):

$$\begin{aligned} \bar{P}_{10} &= \frac{6}{\pi} \cdot \frac{1}{2} \cdot 1.225 \cdot 6^3 = 252.67 \text{ W/m}^2 \\ \bar{P}_{50} &= \bar{P}_{10} \left(\frac{H_{50}}{H_{10}}\right)^{3\alpha} = 252.67 \left(\frac{50}{10}\right)^{3 \times 1/7} = 504 \text{ W/m}^2 \end{aligned}$$

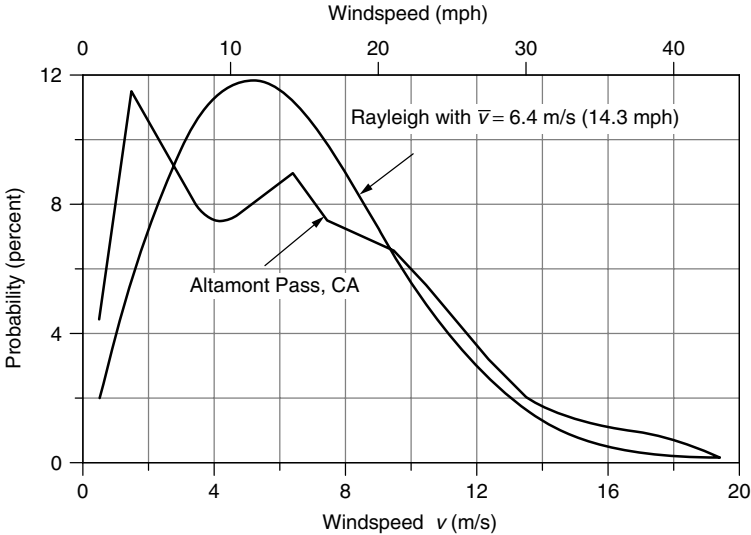

**Figure 6.26** Probability density functions for winds at Altamont Pass, CA., and a Rayleigh p.d.f. with the same average wind speed of 6.4 m/s (14.3 mph). From Cavallo et al. (1993).

Lest we become too complacent about the importance of gathering real wind data rather than relying on Rayleigh assumptions, consider Fig. 6.26, which shows the probability density function for winds at one of California’s biggest wind farms, Altamont Pass. Altamont Pass is located roughly midway between San Francisco (on the coast) and Sacramento (inland valley). In the summer months, rising hot air over Sacramento draws cool surface air through Altamont Pass, creating strong summer afternoon winds, but in the winter there isn’t much of a temperature difference and the winds are generally very light unless a storm is passing through. The windspeed p.d.f. for Altamont clearly shows the two humps that correspond to not much wind for most of the year, along with very high winds on hot summer afternoons. For comparison, a Rayleigh p.d.f. with the same annual average wind speed as Altamont (6.4 m/s) has also been drawn in Fig. 6.26.

**6.8.5 Wind Power Classifications and U.S. Potential**

The procedure demonstrated in Example 6.10 is commonly used to estimate average wind power density ( $W/m^2$ ) in a region. That is, measured values of average wind speed using an anemometer located 10 m above the ground are used to estimate average windspeed and power density at a height 50 m above the ground. Rayleigh statistics, a friction coefficient of 1/7, and sea-level air density at 0°C of 1.225 kg/m<sup>3</sup> are often assumed. A standard wind power classification scheme based on these assumptions is given in Table 6.5.

A map of the United States showing regions of equal wind power density based on the above assumptions is shown in Fig. 6.27. As can be seen, there is a broad

**TABLE 6.5 Standard Wind Power Classifications<sup>a</sup>**

Wind Power Class	Avg Windspeed at 10 m (m/s)	Avg Windspeed at 10 m (mph)	Wind Power Density at 10 m (W/m <sup>2</sup> )	Wind Power Density at 50 m (W/m <sup>2</sup> )
1	0–4.4	0–9.8	0–100	0–200
2	4.4–5.1	9.8–11.4	100–150	200–300
3	5.1–5.6	11.4–12.5	150–200	300–400
4	5.6–6.0	12.5–13.4	200–250	400–500
5	6.0–6.4	13.4–14.3	250–300	500–600
6	6.4–7.0	14.3–15.7	300–400	600–800
7	7.0–9.5	15.7–21.5	400–1000	800–2000

<sup>a</sup>Assumptions include Rayleigh statistics, ground friction coefficient  $\alpha = 1/7$ , sea-level 0°C air density 1.225 kg/m<sup>3</sup>, 10-m anemometer height, 50-m hub height.

band of states stretching from Texas to North Dakota with especially high wind power potential, including large areas with Class 4 or better winds (over 400 W/m<sup>2</sup>).

Translating available wind power from maps such as shown in Fig. 6.27 into estimates of electrical energy that can be developed is an especially important exercise for energy planners and policy makers. While the resource may be available, there are significant land use questions that could limit the acceptability of any given site. Flat grazing lands would be easy to develop, and the impacts on current usage of such lands would be minimal. On the other hand, developing sites in heavily forested areas or along mountain ridges, for example, would be

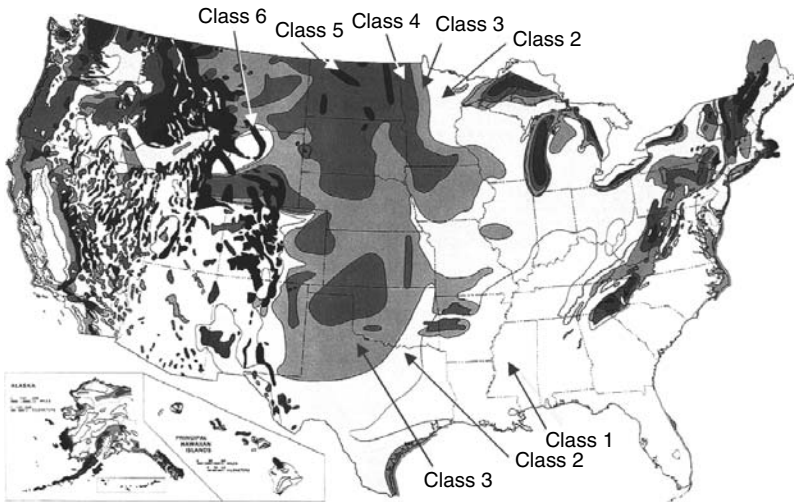

**Figure 6.27** Average annual wind power density at 50-m elevation. From NREL Wind Energy Resource Atlas of the United States.

**TABLE 6.6 Energy Potential for Class 3 or Higher Winds, in billion kWh/yr, Including Environmental and Land Use Constraints**

Rank	State	Potential	Percent of United States <sup>a</sup>	Rank	State	Potential	Percent of United States <sup>a</sup>
1	North Dakota	1210	35%	11	Colorado	481	14%
2	Texas	1190	34%	12	New Mexico	435	12%
3	Kansas	1070	31%	13	Idaho	73	2%
4	South Dakota	1030	29%	14	Michigan	65	2%
5	Montana	1020	29%	15	New York	62	2%
6	Nebraska	868	25%	16	Illinois	61	2%
7	Wyoming	747	21%	17	California	59	2%
8	Oklahoma	725	21%	18	Wisconsin	58	2%
9	Minnesota	657	19%	19	Maine	56	2%
10	Iowa	551	16%	20	Missouri	52	1%

<sup>a</sup>If totally utilized, the fraction of U.S. demand that wind could supply.

Source: Elliot et al. (1991).

much more difficult and environmentally damaging. Proximity to transmission lines and load centers affects the economic viability of projects, although in the future we could imagine wind generated electricity being converted, near the site, into hydrogen that could be pipelined to customers.

One attempt to incorporate land-use constraints into the estimate of U.S. wind energy potential was made by the Pacific Northwest Laboratory (Elliott et al., 1991). Assuming turbine efficiency of 25% and 25% array and system losses, the exploitable wind resource for the United States with no land-use restrictions is estimated to be 16,700 billion kWh/yr and 4600 billion kWh/yr under the most “severe” land use constraints. For comparison, the total amount of electricity generated in the United States in 2002 was about 3500 billion kWh, which means in theory that there is more than enough wind to supply all of U.S. electrical demand. Distances from windy sites to transmission lines and load centers, along with reliability issues, will constrain the total generation to considerably less than that, but nonetheless the statistic is impressive.

The top 20 states for wind energy potential are shown in Table 6.6. Notice that California, which in 2003 had the largest installed wind capacity, ranks only seventeenth among the states for wind potential. At the top of the list is North Dakota, with enough wind potential of its own to supply one-third of the total U.S. electrical demand.

## 6.9 SIMPLE ESTIMATES OF WIND TURBINE ENERGY

How much of the energy in the wind can be captured and converted into electricity? The answer depends on a number of factors, including the characteristics of the machine (rotor, gearbox, generator, tower, controls), the terrain (topography,

surface roughness, obstructions), and, of course, the wind regime (velocity, timing, predictability). It also depends on the purpose behind the question. Are you an energy planner trying to estimate the contribution to overall electricity demand in a region that generic wind turbines might be able to make, or are you concerned about the performance of one wind turbine versus another? Is it for a homework question or are you investing millions of dollars in a wind farm somewhere? Some energy estimates can be made with “back of the envelope” calculations, and others require extensive wind turbine performance specifications and wind data for the site.

### 6.9.1 Annual Energy Using Average Wind Turbine Efficiency

Suppose that the wind power density has been evaluated for a site. If we make reasonable assumptions of the overall conversion efficiency into electricity by the wind turbine, we can estimate the annual energy delivered. We already know that the highest efficiency possible for the rotor itself is 59.3%. In optimum conditions, a modern rotor will deliver about three-fourths of that potential. To keep from overpowering the generator, however, the rotor must spill some of the most energetic high-speed winds, and low-speed winds are also neglected when they are too slow to overcome friction and generator losses. As Example 6.7 suggested, the gearbox and generator deliver about two-thirds of the shaft power created by the rotor. Combining all of these factors leaves us with an overall conversion efficiency from wind power to electrical power of perhaps 30%. Later in the chapter, more careful calculations of wind turbine performance will be made, but quick, simple estimates can be made based on wind classifications and overall efficiencies.

---

**Example 6.11 Annual Energy Delivered by a Wind Turbine.** Suppose that a NEG Micon 750/48 (750-kW generator, 48-m rotor) wind turbine is mounted on a 50-m tower in an area with 5-m/s average winds at 10-m height. Assuming standard air density, Rayleigh statistics, Class 1 surface roughness, and an overall efficiency of 30%, estimate the annual energy (kWh/yr) delivered.

**Solution.** We need to find the average power in the wind at 50 m. Since “surface roughness class” is given rather than the friction coefficient  $\alpha$ , we need to use (6.16) to estimate wind speed at 50 m. From Table 6.4, we find the roughness length  $z$  for Class 1 to be 0.03 m. The average windspeed at 50 m is thus

$$v_{50} = v_{10} \frac{\ln(H_{50}/z)}{\ln(H_{10}/z)} = 5 \text{ m/s} \cdot \frac{\ln(50/0.03)}{\ln(10/0.03)} = 6.39 \text{ m/s}$$

Average power in the wind at 50 m is therefore (6.48)

$$\bar{P}_{50} = \frac{6}{\pi} \cdot \frac{1}{2} \rho \bar{v}^3 = 1.91 \times 0.5 \times 1.225 \times (6.39)^3 = 304.5 \text{ W/m}^2$$

Since this 48-m machine collects 30% of that, then, in a year with 8760 hours, the energy delivered would be

$$\begin{aligned} \text{Energy} &= 0.3 \times 304.5 \text{ W/m}^2 \times \frac{\pi}{4} (48 \text{ m})^2 \times 8760 \text{ h/yr} \times \frac{1 \text{ kW}}{1000 \text{ W}} \\ &= 1.45 \times 10^6 \text{ kWh/yr} \end{aligned}$$

---

## 6.9.2 Wind Farms

Unless it is a single wind turbine for a particular site, such as an off-grid home in the country, most often when a good wind site has been found it makes sense to install a large number of wind turbines in what is often called a *wind farm* or a *wind park*. Obvious advantages result from clustering wind turbines together at a windy site. Reduced site development costs, simplified connections to transmission lines, and more centralized access for operation and maintenance, all are important considerations.

So how many turbines can be installed at a given site? Certainly wind turbines located too close together will result in upwind turbines interfering with the wind received by those located downwind. As we know, the wind is slowed as some of its energy is extracted by a rotor, which reduces the power available to downwind machines. Eventually, however, some distance downwind, the wind speed recovers. Theoretical studies of square arrays with uniform, equal spacing illustrate the degradation of performance when wind turbines are too close together. For one such study, Figure 6.28 shows array efficiency (predicted output divided by the power that would result if there were no interference) as a function of tower spacing expressed in rotor diameters. The parameter is the number of turbines in an equally-spaced array. That is, for example, a  $2 \times 2$  array consists of four wind turbines equally spaced within a square area, while an  $8 \times 8$  array is 64 turbines in a square area. The larger the array, the greater the interference, so array efficiency drops.

Figure 6.28 shows that interference out to at least 9 rotor diameters for all of these square array sizes, but for small arrays performance degradation is modest, less than about 20% for 6-diameter spacing with 16 turbines. Intuitively, an array area should not be square, as was the case for the study shown in Fig. 6.28, but rectangular with only a few long rows perpendicular to the prevailing winds, with each row having many turbines. Experience has yielded some rough rules-of-thumb for tower spacing of such rectangular arrays. Recommended spacing is 3–5 rotor diameters separating towers within a row and 5–9 diameters between rows. The offsetting, or staggering, of one row of towers behind another, as illustrated in Fig. 6.29 is also common.

We can now make some preliminary estimates of the wind energy potential per unit of land area as the following example suggests.

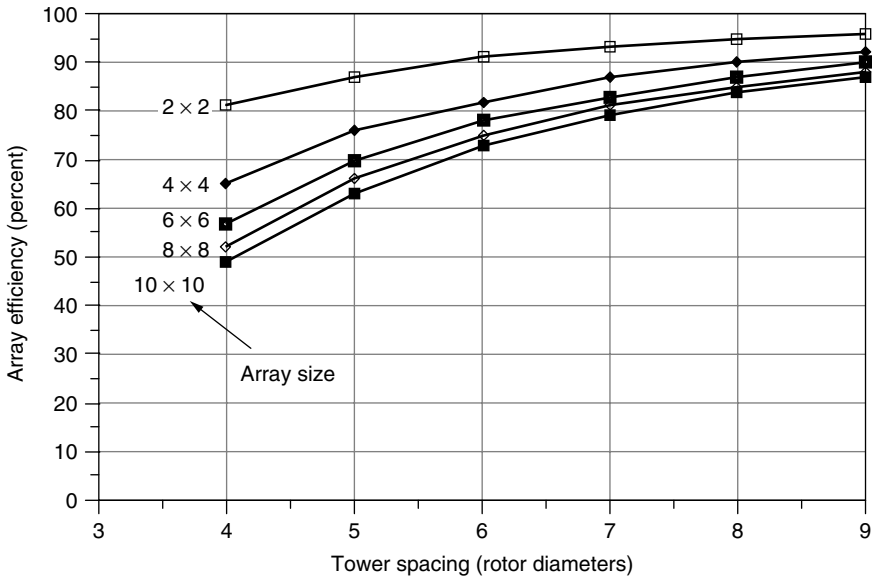

**Figure 6.28** Impact of tower spacing and array size on performance of wind turbines. *Source:* Data in Milborrow and Surman (1987), presented in Grubb and Meyer (1993).

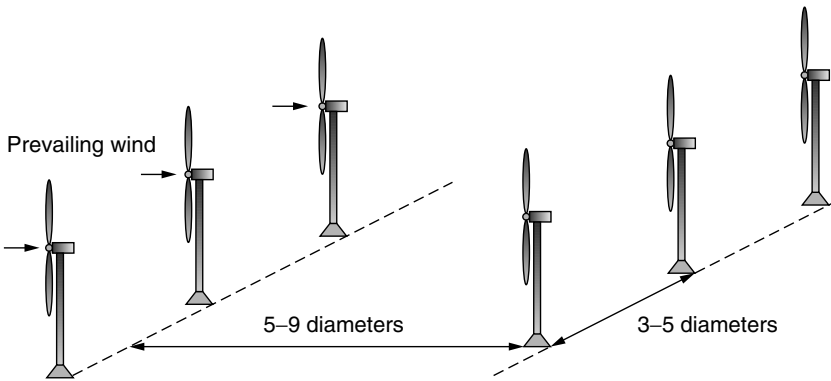

**Figure 6.29** Optimum spacing of towers is estimated to be 3–5 rotor diameters between wind turbines within a row and 5–9 diameters between rows.

**Example 6.12 Energy Potential for a Wind Farm.** Suppose that a wind farm has 4-rotor-diameter tower spacing along its rows, with 7-diameter spacing between rows ( $4D \times 7D$ ). Assume 30% wind turbine efficiency and an array efficiency of 80%.

- a. Find the annual energy production per unit of land area in an area with  $400\text{-W/m}^2$  winds at hub height (the edge of 50 m, Class 4 winds).
- b. Suppose that the owner of the wind turbines leases the land from a rancher for \$100 per acre per year (about 10 times what a Texas rancher makes on cattle). What does the lease cost per kWh generated?

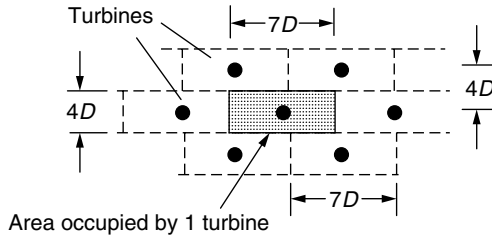

### Solution

- a. As the figure suggests, the land area occupied by one wind turbine is  $4D \times 7D = 28D^2$ , where  $D$  is the diameter of the rotor. The rotor area is  $(\pi/4)D^2$ . The energy produced per unit of land area is thus

$$\begin{aligned} \frac{\text{Energy}}{\text{Land area}} &= \frac{1}{28D^2} \left( \frac{\text{Wind turbine}}{\text{m}^2 \text{ land}} \right) \cdot \frac{\pi}{4} D^2 \left( \frac{\text{m}^2 \text{ rotor}}{\text{Wind turbine}} \right) \\ &\quad \times 400 \left( \frac{\text{W}}{\text{m}^2 \text{ rotor}} \right) \times 0.30 \times 0.80 \times 8760 \frac{\text{h}}{\text{yr}} \\ \frac{\text{Energy}}{\text{Land area}} &= 23,588 \frac{\text{W} \cdot \text{h}}{\text{m}^2 \cdot \text{yr}} = 23.588 \frac{\text{kWh}}{\text{m}^2 \cdot \text{yr}} \end{aligned}$$

- b. At  $4047 \text{ m}^2$  per acre, the annual energy produced per acre is:

$$\frac{\text{Energy}}{\text{Land area}} = 23.588 \frac{\text{kWh}}{\text{m}^2 \cdot \text{yr}} \times \frac{4047 \text{ m}^2}{\text{acre}} = 95,461 \frac{\text{kWh}}{\text{acre} \cdot \text{yr}}$$

so, leasing the land costs the wind farmer:

$$\frac{\text{Land cost}}{\text{kWh}} = \frac{\$100}{\text{acre} \cdot \text{yr}} \times \frac{\text{acre} \cdot \text{yr}}{95,461 \text{ kWh}} = \$0.00105/\text{kWh} = 0.1 \text{ ¢/kWh}$$

The land leasing computation in the above example illustrates an important point. Wind farms are quite compatible with conventional farming, especially cattle ranching, and the added revenue a farmer can receive by leasing land to a wind park is often more than the value of the crops harvested on that same land.



As a result, ranchers and farmers are becoming some of the strongest proponents of wind power since it helps them to stay in their primary business while earning higher profits.

## 6.10 SPECIFIC WIND TURBINE PERFORMANCE CALCULATIONS

The techniques already described that help us go from power in the wind to electrical energy delivered have used only simple estimates of overall system efficiency linked to wind probability statistics. Now we will introduce techniques that can be applied to individual wind turbines based on their own specific performance characteristics.

### 6.10.1 Some Aerodynamics

In order to understand some aspects of wind turbine performance, we need a brief introduction to how rotor blades extract energy from the wind. Begin by considering the simple airfoil cross section shown in Fig. 6.30a. An airfoil, whether it is the wing of an airplane or the blade of a windmill, takes advantage of Bernoulli's principle to obtain lift. Air moving over the top of the airfoil has a greater distance to travel before it can rejoin the air that took the short cut under the foil. That means that the air pressure on top is lower than that under the airfoil, which creates the lifting force that holds an airplane up or that causes a wind turbine blade to rotate.

Describing the forces on a wind turbine blade is a bit more complicated than for a simple aircraft wing. A rotating turbine blade sees air moving toward it not only from the wind itself, but also from the relative motion of the blade as it rotates. As shown in Fig. 6.30b, the combination of wind and blade motion is

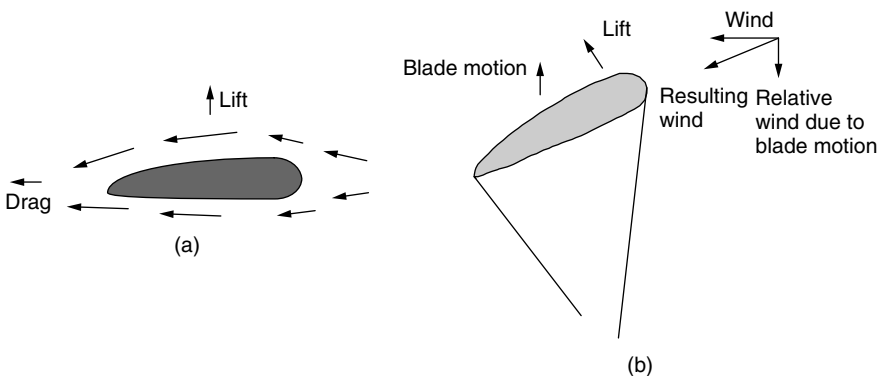

**Figure 6.30** The lift in (a) is the result of faster air sliding over the top of the wind foil. In (b), the combination of actual wind and the relative wind due to blade motion creates a resultant that creates the blade lift.

like adding two vectors, with the resultant moving across the airfoil at the correct angle to obtain lift that moves the rotor along. Since the blade is moving much faster at the tip than near the hub, the blade must be twisted along its length to keep the angles right.

Up to a point, increasing the angle between the airfoil and the wind (called the angle of attack), improves lift at the expense of increased drag. As shown in Fig. 6.31, however, increasing the angle of attack too much can result in a phenomenon known as stall. When a wing stalls, the airflow over the top no longer sticks to the surface and the resulting turbulence destroys lift. When an aircraft climbs too steeply, stall can have tragic results.

**6.10.2 Idealized Wind Turbine Power Curve**

The most important technical information for a specific wind turbine is the power curve, which shows the relationship between windspeed and generator electrical output. A somewhat idealized power curve is shown in Fig. 6.32.

**Cut-in Windspeed.** Low-speed winds may not have enough power to overcome friction in the drive train of the turbine and, even if it does and the generator is

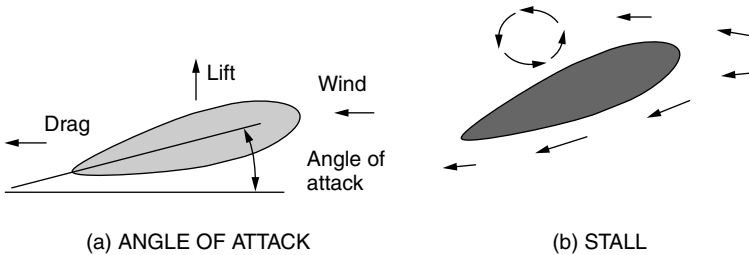

**Figure 6.31** Increasing the angle of attack can cause a wing to stall.

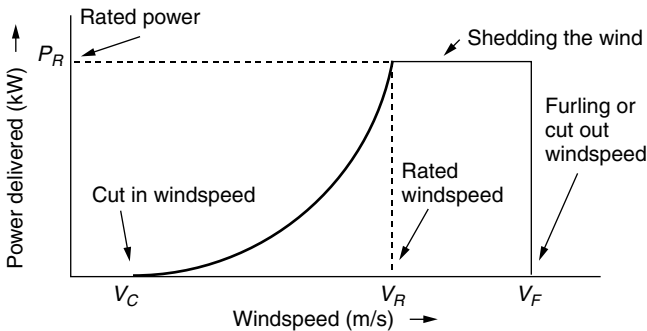

**Figure 6.32** Idealized power curve. No power is generated at windspeeds below  $V_C$ ; at windspeeds between  $V_R$  and  $V_F$ , the output is equal to the rated power of the generator; above  $V_F$  the turbine is shut down.

rotating, the electrical power generated may not be enough to offset the power required by the generator field windings. The cut-in windspeed  $V_C$  is the minimum needed to generate net power. Since no power is generated at windspeeds below  $V_C$ , that portion of the wind's energy is wasted. Fortunately, there isn't much energy in those low-speed winds anyway, so usually not much is lost.

**Rated Windspeed.** As velocity increases above the cut-in windspeed, the power delivered by the generator tends to rise as the cube of windspeed. When winds reach the rated windspeed  $V_R$ , the generator is delivering as much power as it is designed for. Above  $V_R$ , there must be some way to shed some of the wind's power or else the generator may be damaged. Three approaches are common on large machines: an active pitch-control system, a passive stall-control design, and a combination of the two.

For *pitch-controlled* turbines an electronic system monitors the generator output power; if it exceeds specifications, the pitch of the turbine blades is adjusted to shed some of the wind. Physically, a hydraulic system slowly rotates the blades about their axes, turning them a few degrees at a time to reduce or increase their efficiency as conditions dictate. The strategy is to reduce the blade's angle of attack when winds are high.

For *stall-controlled* machines, the blades are carefully designed to automatically reduce efficiency when winds are excessive. Nothing rotates—as it does in the pitch-controlled scheme—and there are no moving parts, so this is referred to as passive control. The aerodynamic design of the blades, especially their twist as a function of distance from the hub, must be very carefully done so that a gradual reduction in lift occurs as the blades rotate faster. The majority of modern, large wind turbines use this passive, stall-controlled approach.

For very large machines, above about 1 MW, an *active stall control* scheme may be justified. For these machines, the blades rotate just as they do in the active, pitch-control approach. The difference is, however, that when winds exceed the rated windspeed, instead of reducing the angle of attack of the blades, it is increased to induce stall.

Small, kilowatt-size wind turbines can have any of a variety of techniques to spill wind. Passive yaw controls that cause the axis of the turbine to move more and more off the wind as windspeeds increase are common. This can be accomplished by mounting the turbine slightly to the side of the tower so that high winds push the entire machine around the tower. Another simple approach relies on a wind vane mounted parallel to the plane of the blades. As winds get too strong, wind pressure on the vane rotate the machine away from the wind.

**Cut-out or Furling Windspeed.** At some point the wind is so strong that there is real danger to the wind turbine. At this windspeed  $V_F$ , called the cut-out windspeed or the furling windspeed (“furling” is the term used in sailing to describe the practice of folding up the sails when winds are too strong), the machine must be shut down. Above  $V_F$ , output power obviously is zero.

For pitch-controlled and active stall-controlled machines, the rotor can be stopped by rotating the blades about their longitudinal axis to create a stall. For

stall-controlled machines, it is common on large turbines to have spring-loaded, rotating tips on the ends of the blades. When activated, a hydraulic system trips the spring and the blade tips rotate  $90^\circ$  out of the wind, stopping the turbine in a few rotor revolutions. If the hydraulic system fails, the springs automatically activate when rotor speed is excessive. Once a rotor has been stopped, by whatever control mechanism, a mechanical brake locks the rotor shaft in place, which is especially important for safety during maintenance.

### 6.10.3 Optimizing Rotor Diameter and Generator Rated Power

The idealized power curve of Fig. 6.32 provides a convenient framework within which to consider the trade-offs between rotor diameter and generator size as ways to increase the energy delivered by a wind turbine. As shown in Fig. 6.33a, increasing the rotor diameter, while keeping the same generator, shifts the power curve upward so that rated power is reached at a lower windspeed. This strategy increases output power for lower-speed winds. On the other hand, keeping the same rotor but increasing the generator size allows the power curve to continue upward to the new rated power. For lower-speed winds, there isn't much change, but in an area with higher wind speeds, increasing the generator rated power is a good strategy.

Manufacturers will sometimes offer a line of turbines with various rotor diameters and generator ratings so that customers can best match the distribution of windspeeds with an appropriate machine. In areas with relatively low windspeeds, a larger rotor diameter may be called for. In areas with relatively high windspeeds, it may be better to increase the generator rating.

### 6.10.4 Wind Speed Cumulative Distribution Function

Recall some of the important properties of a probability density function for wind speeds. The total area under a probability density function curve is equal to one,

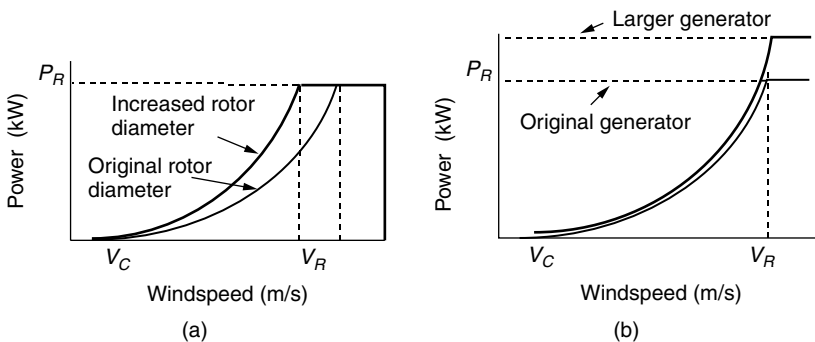

**Figure 6.33** (a) Increasing rotor diameter reduces the rated windspeed, emphasizing lower speed winds. (b) Increasing the generator size increases rated power, emphasizing higher windspeeds.

and the area between any two windspeeds is the probability that the wind is between those speeds. Therefore, the probability that the wind is less than some specified windspeed  $V$  is given by

$$\text{prob}(v \leq V) = F(V) = \int_0^V f(v) dv \quad (6.49)$$

The integral  $F(V)$  in (6.49) is given a special name: the *cumulative distribution function*. The probability that the wind  $V$  is less than 0 is 0, and the probability that the wind is less than infinity is 1, so  $F(V)$  has the following constraints:

$$F(V) = \text{probability } v \leq V, \quad F(0) = 0, \quad \text{and} \quad F(\infty) = 1 \quad (6.50)$$

In the field of wind energy, the most important p.d.f. is the Weibull function given before as (6.41):

$$f(v) = \frac{k}{c} \left(\frac{v}{c}\right)^{k-1} \exp\left[-\left(\frac{v}{c}\right)^k\right] \quad (6.41)$$

The cumulative distribution function for Weibull statistics is therefore

$$F(V) = \text{prob}(v \leq V) = \int_0^V \frac{k}{c} \left(\frac{v}{c}\right)^{k-1} \exp\left[-\left(\frac{v}{c}\right)^k\right] dv \quad (6.51)$$

This integral looks pretty imposing. The trick to the integration is to make the change of variable:

$$x = \left(\frac{v}{c}\right)^k \quad \text{so that } dx = \frac{k}{c} \left(\frac{v}{c}\right)^{k-1} dv \quad \text{and} \quad F(V) = \int_0^x e^{-x} dx \quad (6.52)$$

which results in

$$F(V) = \text{prob}(v \leq V) = 1 - \exp\left[-\left(\frac{V}{c}\right)^k\right] \quad (6.53)$$

For the special case of Rayleigh statistics,  $k = 2$ , and from (6.44)  $c = \frac{2\bar{v}}{\sqrt{\pi}}$ , where  $\bar{v}$  is the average windspeed, the probability that the wind is less than  $V$  is given by

$$F(V) = \text{prob}(v \leq V) = 1 - \exp\left[-\frac{\pi}{4} \left(\frac{V}{\bar{v}}\right)^2\right] \quad (\text{Rayleigh}) \quad (6.54)$$

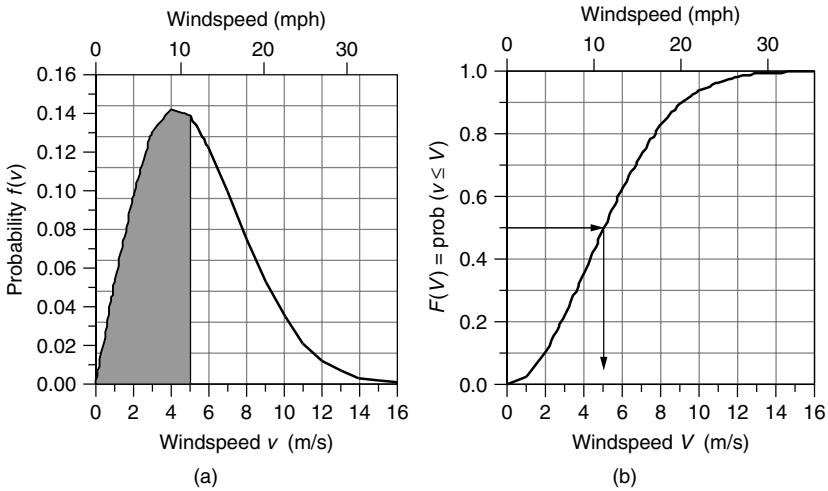

**Figure 6.34** An example p.d.f. (a) and cumulative distribution function (b) for  $k = 2$ ,  $c = 6$  Weibull statistics. In this case, half the time the wind is less than or equal to 5 m/s; that is, half the area under the p.d.f. is to the left of  $v = 5$  m/s.

A graph of a Weibull p.d.f.  $f(v)$  and its cumulative distribution function,  $F(V)$ , is given in Fig. 6.34. The example shown there has  $k = 2$  and  $c = 6$ , so it is actually a Rayleigh p.d.f. The figure shows that half of the time the wind is less than or equal to 5 m/s; that is, half the area under the  $f(v)$  curve falls to the left of 5 m/s, and  $F(5) = 0.5$ . Note that this does not mean the average windspeed is 5 m/s. In fact, since this example is a Rayleigh p.d.f., the average windspeed is given by (6.44):  $\bar{v} = c\sqrt{\pi}/2 = 6\sqrt{\pi}/2 = 5.32$  m/s.

Also of interest is the probability that the wind is greater than a certain value

$$\text{prob}(v \geq V) = 1 - \text{prob}(v \leq V) = 1 - F(V) \tag{6.55}$$

For Weibull statistics, (6.55) becomes

$$\text{prob}(v \geq V) = 1 - \left\{ 1 - \exp \left[ - \left( \frac{V}{c} \right)^k \right] \right\} = \exp \left[ - \left( \frac{V}{c} \right)^k \right] \tag{6.56}$$

and for Rayleigh statistics,

$$\text{prob}(v \geq V) = \exp \left[ - \frac{\pi}{4} \left( \frac{V}{\bar{v}} \right)^2 \right] \quad (\text{Rayleigh}) \tag{6.57}$$

---

**Example 6.13 Idealized Power Curve with Rayleigh Statistics.** A NEG Micon 1000/54 wind turbine (1000-kW rated power, 54-m-diameter rotor) has a

cut-in windspeed  $V_C = 4$  m/s, rated windspeed  $V_R = 14$  m/s, and a furling wind speed of  $V_F = 25$  m/s. If this machine is located in Rayleigh winds with an average speed of 10 m/s, find the following:

- How many h/yr is the wind below the cut-in wind speed?
- How many h/yr will the turbine be shut down due to excessive winds?
- How many kWh/yr will be generated when the machine is running at rated power?

**Solution**

- Using (6.54), the probability that the windspeed is below cut-in 4 m/s is

$$\begin{aligned} F(V_C) &= \text{prob}(v \leq V_C) = 1 - \exp\left[-\frac{\pi}{4} \left(\frac{V_C}{\bar{v}}\right)^2\right] \\ &= 1 - \exp\left[-\frac{\pi}{4} \left(\frac{4}{10}\right)^2\right] = 0.1181 \end{aligned}$$

In a year with 8760 hours ( $365 \times 24$ ), the number of hours the wind will be less than 4 m/s is

$$\text{Hours}(v \leq 4 \text{ m/s}) = 8760 \text{ h/yr} \times 0.1181 = 1034 \text{ h/yr}$$

- Using (6.57), the hours when the wind is higher than  $V_F = 25$  m/s will be

$$\begin{aligned} \text{Hours}(v \geq V_F) &= 8760 \cdot \exp\left[-\frac{\pi}{4} \left(\frac{V_F}{\bar{v}}\right)^2\right] = 8760 \cdot \exp\left[-\frac{\pi}{4} \left(\frac{25}{10}\right)^2\right] \\ &= 65 \text{ h/yr} \end{aligned}$$

that is, about 2.5 days per year the turbine will be shut down due to excessively high speed winds.

- The wind turbine will deliver its rated power of 1000 kW any time the wind is between  $V_R = 14$  m/s and  $V_F = 25$  m/s. The number of hours that the wind is higher than 14 m/s is

$$\text{Hours}(v \geq 14) = 8760 \cdot \exp\left[-\frac{\pi}{4} \left(\frac{14}{10}\right)^2\right] = 1879 \text{ h/yr}$$

So, the number of hours per year that the winds blow between 14 m/s and 25 m/s is  $1879 - 65 = 1814$  h/yr. The energy the turbine delivers from those winds will be

$$\text{Energy}(V_R \leq v \leq V_F) = 1000 \text{ kW} \times 1814 \text{ h/yr} = 1.814 \times 10^6 \text{ kWh/yr}$$

---

### 6.10.5 Using Real Power Curves with Weibull Statistics

Figure 6.35 shows power curves for three wind turbines: the NEG Micon 1500/64 (rated power is 1500 kW; rotor diameter is 64 m), the NEG Micon 1000/54, and the Vestas V42 600/42. Their resemblance to the idealized power curve is apparent, with most of the discrepancy resulting from the inability of wind-shedding techniques to precisely control output when winds exceed the rated windspeed. Notice how the rounding of the curve in the vicinity of the rated power makes it difficult to determine what an appropriate value of the rated windspeed  $V_R$  should be. As a result, rated windspeed is used less often these days as part of turbine product literature.

With the power curve in hand, we know the power delivered at any given wind speed. If we combine the power at any wind speed with the hours the wind blows at that speed, we can sum up total kWh of energy produced. If the site has data for hours at each wind speed, those would be used to calculate the energy delivered. Alternatively, when wind data are incomplete, it is customary to assume Weibull statistics with an appropriate shape parameter  $k$ , and scale parameter  $c$ . If only the average wind speed is known  $\bar{v}$ , we can use the simpler Rayleigh statistics with  $k = 2$  and  $c = \frac{2\bar{v}}{\sqrt{\pi}}$ .

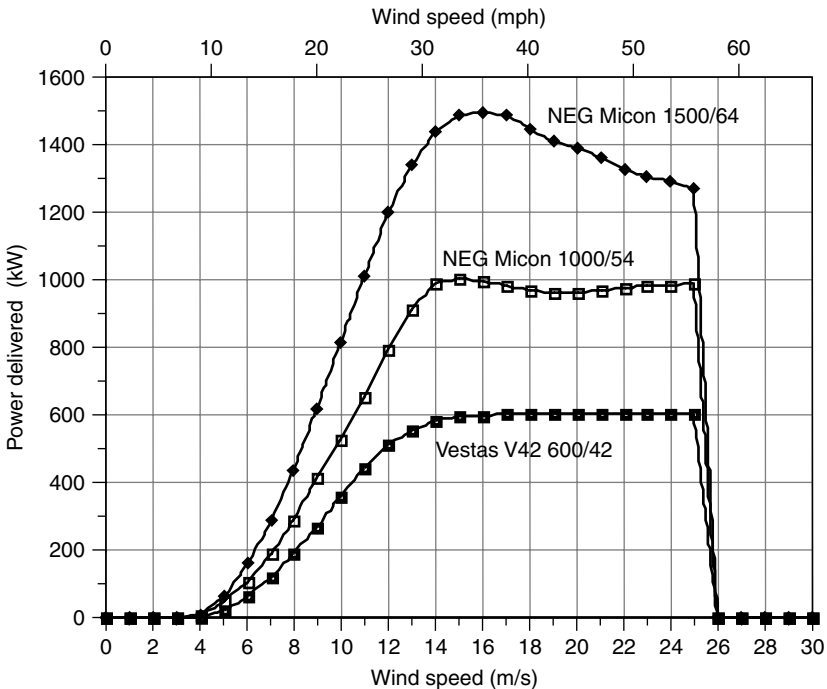

**Figure 6.35** Power curves for three large wind turbines.



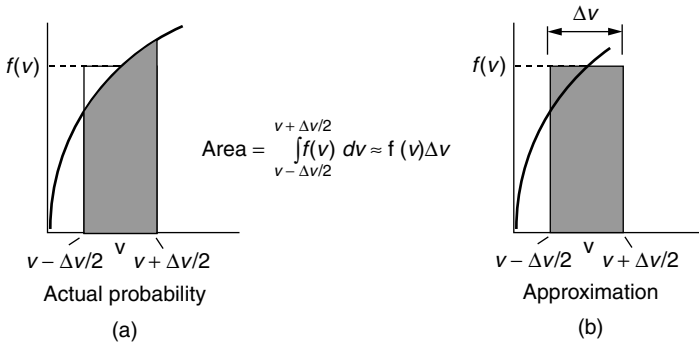

**Figure 6.36** The probability that  $v$  is within  $v \pm \Delta v/2$  is the shaded area in (a). A reasonable approximation is the shaded area in (b)  $f(v)\Delta v$ , as long as  $\Delta v$  is relatively small.

We started the description of wind statistics using discrete values of wind speed and hours per year at that wind speed, then moved on to continuous probability density functions. It is time to take a step backwards and modify the continuous p.d.f. to estimate hours at discrete wind speeds. With hours at any given speed and turbine power at that speed, we can easily do a summation to find energy produced.

Suppose we ask: What is the probability that the wind blows at some specified speed  $v$ ? A statistician will tell you that the correct answer is zero. It never blows at *exactly*  $v$  m/s. The legitimate question is, What is the probability that the wind blows between  $v - \Delta v/2$  and  $v + \Delta v/2$ ? On a p.d.f., this probability is the area under the curve between  $v - \Delta v/2$  and  $v + \Delta v/2$  as shown in Fig. 6.36a. If  $\Delta v$  is small enough, then a reasonable approximation is the rectangular area shown in Fig. 6.36b. This suggests we can make the following approximation:

$$\text{prob}(v - \Delta v/2 \leq V \leq v + \Delta v/2) = \int_{v - \Delta v/2}^{v + \Delta v/2} f(v) \, dv \approx f(v) \Delta v \quad (6.58)$$

While this may look complicated, it really makes life very simple. It says we can conveniently discretize a continuous p.d.f. by saying the probability that the wind blows at some windspeed  $V$  is just  $f(V)$ , and let the statisticians squirm. Let's us check the following example to see if this seems reasonable.

**Example 6.14 Discretizing  $f(v)$ .** For a wind site with Rayleigh winds having average speed  $\bar{v} = 8$  m/s, what is the probability that the wind would blow between 6.5 and 7.5 m/s? How does this compare to the p.d.f. evaluated at 7 m/s?

**Solution.** Using (6.57), we obtain

$$\text{prob}(v \geq 6.5) = \exp \left[ -\frac{\pi}{4} \left( \frac{6.5}{8} \right)^2 \right] = 0.59542$$

$$\text{prob}(v \geq 7.5) = \exp \left[ -\frac{\pi}{4} \left( \frac{7.5}{8} \right)^2 \right] = 0.50143$$

So, the probability that the wind is between 6.5 and 7.5 m/s is

$$\text{prob}(6.5 \leq v \leq 7.5) = 0.59542 - 0.50143 = 0.09400$$

From (6.45), we will approximate the probability that the wind is at 7 m/s to be

$$f(v) = \frac{\pi v}{2v^2} \exp \left[ -\frac{\pi}{4} \left( \frac{v}{v} \right)^2 \right]$$

so,

$$f(7 \text{ m/s}) = \frac{\pi \cdot 7}{2 \cdot 8^2} \exp \left[ -\frac{\pi}{4} \left( \frac{7}{8} \right)^2 \right] = 0.09416$$

The approximation 0.09416 is only 0.2% higher than the correct value of 0.09400.

The above example is reassuring. It suggests that we can use the p.d.f. evaluated at integer values of windspeed to represent the probability that the wind blows at that speed. Combining power curve data supplied by the turbine manufacturer (examples are given in Table 6.7), with appropriate wind statistics, gives us a straightforward way to estimate annual energy production. This is most easily done using a spreadsheet. Example 6.15 demonstrates the process.

**Example 6.15 Annual Energy Delivered Using a Spreadsheet.** Suppose that a NEG Micon 60-m diameter wind turbine having a rated power of 1000 kW is installed at a site having Rayleigh wind statistics with an average windspeed of 7 m/s at the hub height.

- a. Find the annual energy generated.
- b. From the result, find the overall average efficiency of this turbine in these winds.
- c. Find the productivity in terms of kWh/yr delivered per m<sup>2</sup> of swept area.

**TABLE 6.7 Examples of Wind Turbine Power Specifications**

		NEG	NEG	NEG			Wind		
Manufacturer:		Micon	Micon	Micon	Vestas	Whisper	World	Nordex	Bonus
Rated Power (kW):		1000	1000	1500	600	0.9	250	1300	300
Diameter (m):		60	54	64	42	2.13	29.2	60	33.4
Avg. Windspeed									
<i>v</i> (m/s)	<i>v</i> (mph)	kW	kW	kW	kW	kW	kW	kW	kW
0	0	0	0	0	0	0.00	0	0	0
1	2.2	0	0	0	0	0.00	0	0	0
2	4.5	0	0	0	0	0.00	0	0	0
3	6.7	0	0	0	0	0.03	0	0	4
4	8.9	33	10	9	0	0.08	0	25	15
5	11.2	86	51	63	22	0.17	12	78	32
6	13.4	150	104	159	65	0.25	33	150	52
7	15.7	248	186	285	120	0.35	60	234	87
8	17.9	385	291	438	188	0.45	92	381	129
9	20.1	535	412	615	268	0.62	124	557	172
10	22.4	670	529	812	356	0.78	153	752	212
11	24.6	780	655	1012	440	0.90	180	926	251
12	26.8	864	794	1197	510	1.02	205	1050	281
13	29.1	924	911	1340	556	1.05	224	1159	297
14	31.3	964	986	1437	582	1.08	238	1249	305
15	33.6	989	1006	1490	594	1.04	247	1301	300
16	35.8	1000	998	1497	598	1.01	253	1306	281
17	38.0	998	984	1491	600	1.00	258	1292	271
18	40.3	987	971	1449	600	0.99	260	1283	259
19	42.5	968	960	1413	600	0.97	259	1282	255
20	44.7	944	962	1389	600	0.95	256	1288	253
21	47.0	917	967	1359	600	0.00	250	1292	254
22	49.2	889	974	1329	600	0.00	243	1300	255
23	51.5	863	980	1307	600	0.00	236	1313	256
24	53.7	840	985	1288	600	0.00	230	1328	257
25	55.9	822	991	1271	600	0.00	224	1344	258
26	58.2	0	0	0	0	0.00	0	0	0

Source: Mostly based on data in [www.windpower.dk](http://www.windpower.dk).

**Solution**

- a. To find the annual energy delivered, a spreadsheet solution is called for. Let's do a sample calculation for a 6-m/s windspeed to see how it goes, and then present the spreadsheet results. From Table 6.7, at 6 m/s the NEG Micon 1000/60 generates 150 kW. From (6.45), the Rayleigh p.d.f. at 6 m/s in a regime with 7-m/s average windspeed is

$$f(v) = \frac{\pi v}{2\bar{v}^2} \exp\left[-\frac{\pi}{4} \left(\frac{v}{\bar{v}}\right)^2\right] = \frac{\pi \cdot 6}{2 \cdot 7^2} \exp\left[-\frac{\pi}{4} \left(\frac{6}{7}\right)^2\right] = 0.10801$$

In a year with 8760 h, our estimate of the hours the wind blows at 6 m/s is

$$\text{Hours @6 m/s} = 8760 \text{ h/yr} \times 0.10801 = 946 \text{ h/yr}$$

So the energy delivered by 6-m/s winds is

$$\text{Energy (@6 m/s)} = 150 \text{ kW} \times 946 \text{ h/yr} = 141,929 \text{ kWh/yr}$$

The rest of the spreadsheet is given below. The total energy produced is  $2.85 \times 10^6$  kWh/yr.

Windspeed (m/s)	Power (kW)	Probability $f(v)$	Hrs/yr at $v$	Energy (kWh/yr)
0	0	0.000	0	0
1	0	0.032	276	0
2	0	0.060	527	0
3	0	0.083	729	0
4	33	0.099	869	28,683
5	86	0.107	941	80,885
6	150	0.108	946	141,929
7	248	0.102	896	222,271
8	385	0.092	805	310,076
9	535	0.079	690	369,126
10	670	0.065	565	378,785
11	780	0.051	444	346,435
12	864	0.038	335	289,551
13	924	0.028	243	224,707
14	964	0.019	170	163,779
15	989	0.013	114	113,101
16	1000	0.008	74	74,218
17	998	0.005	46	46,371
18	987	0.003	28	27,709
19	968	0.002	16	15,853
20	944	0.001	9	8,709
21	917	0.001	5	4,604
22	889	0.000	3	2,347
23	863	0.000	1	1,158
24	840	0.000	1	554
25	822	0.000	0	257
26	0	0.000	0	0
<b>Total:</b>				2,851,109

- b. The average efficiency is the fraction of the wind's energy that is actually converted into electrical energy. Since Rayleigh statistics are assumed, we

can use (6.48) to find average power in the wind for a 60-m rotor diameter (assuming the standard value of air density equal to 1.225 kg/m<sup>3</sup>):

$$\begin{aligned} \bar{P} &= \frac{6}{\pi} \cdot \frac{1}{2} \rho A \bar{v}^3 = \frac{6}{\pi} \times 0.5 \times 1.225 \times \frac{\pi}{4} (60)^2 \times (7)^3 \\ &= 1.134 \times 10^6 \text{ W} = 1134 \text{ kW} \end{aligned}$$

In a year with 8760 h, the energy in the wind is

$$\text{Energy in wind} = 8760 \text{ h/yr} \times 1134 \text{ kW} = 9.938 \times 10^6 \text{ kWh}$$

So the average efficiency of this machine in these winds is

$$\text{Average efficiency} = \frac{2.85 \times 10^6 \text{ kWh/yr}}{9.938 \times 10^6 \text{ kWh/yr}} = 0.29 = 29\%$$

c. The productivity (annual energy per swept area) of this machine is

$$\text{Productivity} = \frac{2.85 \times 10^6 \text{ kWh/yr}}{(\pi/4) \cdot 60^2 \text{ m}^2} = 1008 \text{ kWh/m}^2 \cdot \text{yr}$$

A histogram of hours per year and MWh per year at each windspeed for the above example is presented in Fig. 6.37. Notice how little energy is delivered at lower windspeeds in spite of the large number of hours of wind at those speeds. This is, of course, another example of the importance of the cubic relationship between power in the wind and wind speed.

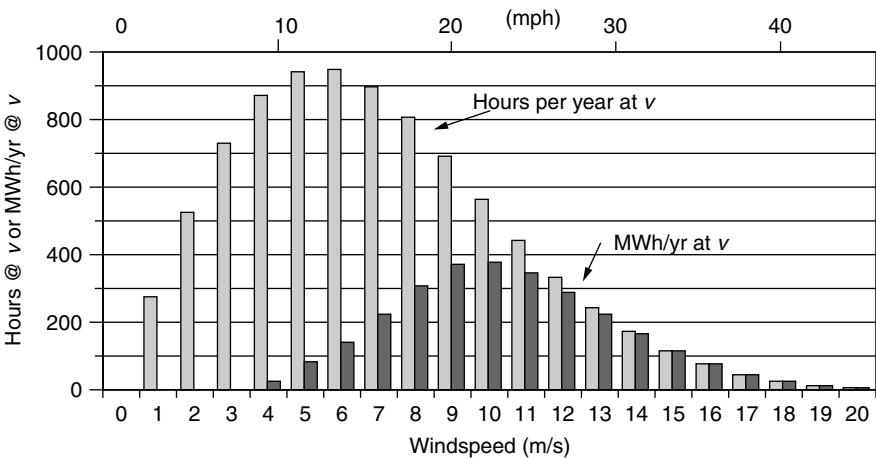

**Figure 6.37** Hours per year and MWh per year at each windspeed for the NEG Micon (1000/60) turbine and Rayleigh winds with average speed 7 m/s.

**6.10.6 Using Capacity Factor to Estimate Energy Produced**

One of the most important characteristics of any electrical power system is its rated power; that is, how many kW it can produce on a continuous, full-power basis. If the system has a generator, the rated power is dictated by the rated output of the generator. If the generator were to deliver rated power for a full year, then the energy delivered would be the product of rated power times 8760 h/yr. Since power systems—especially wind turbines—don’t run at full power all year, they put out something less than that maximum amount. The *capacity factor* CF is a convenient, dimensionless quantity between 0 and 1 that connects rated power to energy delivered:

$$\text{Annual energy (kWh/yr)} = P_R \text{ (kW)} \times 8760 \text{ (h/yr)} \times \text{CF} \tag{6.59}$$

where  $P_R$  is the rated power (kW) and CF is the capacity factor. That is, the capacity factor is

$$\text{CF} = \frac{\text{Actual energy delivered}}{P_R \times 8760} \tag{6.60}$$

Or, another way to express it is

$$\text{CF} = \frac{\text{Actual energy delivered}/8760 \text{ h/yr}}{P_R} = \frac{\text{Average power}}{\text{Rated power}} \tag{6.61}$$

**Example 6.16 Capacity Factor for the NEG Micon 1000/60.** What is the capacity factor for the NEG Micon 1000/60 in Example 6.14?

**Solution**

$$\text{CF} = \frac{\text{Actual energy delivered}}{P_R \times 8760} = \frac{2.851 \times 10^6 \text{ kWh/yr}}{1000 \text{ kW} \times 8760 \text{ h/yr}} = 0.325$$

Example 6.16 is quite artificial, in that a careful calculation of energy delivered was used to find capacity factor. The real purpose of introducing the capacity factor is to do just the opposite—that is, to use it to estimate energy delivered. The goal here is to find a simple way to estimate capacity factor when very little is known about a site and wind turbine.

Suppose we use the procedure just demonstrated in Examples 6.15 and 6.16 to work out the capacity factor for the above wind turbine while we vary the average wind speed. Figure 6.38 shows the result. For mid-range winds averaging from about 4 to 10 m/s (9 to 22 mph), the capacity factor for this machine is quite linear. These winds cover all the way from Class 2 to Class 7 winds, and so they are quite typical of sites for which wind power is attractive. For winds with higher averages, more and more of the wind is above the rated windspeed and

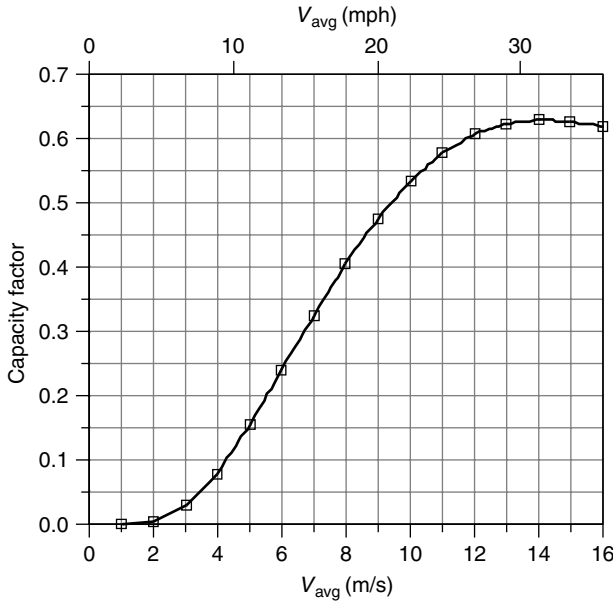

**Figure 6.38** Capacity factor for the NEG Micon 1000/60 assuming Rayleigh wind statistics. For sites with average winds between about 4 and 10 m/s (9 to 22 mph), CF varies quite linearly with average windspeed. Rayleigh statistics are assumed.

capacity factor begins to level out and even drop some. A similar flattening of the curve occurs when the average windspeed is down near the cut-in windspeed and below, since much of the wind produces no electrical power.

The S-shaped curve of Fig. 6.38 was derived for a specific turbine operating in winds that follow Rayleigh statistics. As it turns out, all turbines show the same sort of curve with a sweet spot of linearity in the range of average wind speeds that are likely to be encountered in practice. This suggests the possibility of modeling capacity factor, in the linear region, with an equation of the form

$$CF = m\bar{V} + b \tag{6.62}$$

For the NEG Micon 1000/60, the linear fit shown in Fig. 6.39 leads to the following:

$$CF = 0.087\bar{V} - 0.278 \tag{6.63}$$

The rated power  $P_R$  of the NEG 1000/60 is 1000 kW and the rotor diameter  $D$  is 60 m. The ratio of rated power to the square of rotor diameter is

$$\frac{P_R}{D^2} = \frac{1000 \text{ kW}}{(60 \text{ m})^2} = 0.278 \quad \text{for the NEG Micon 1000/60} \tag{6.64}$$

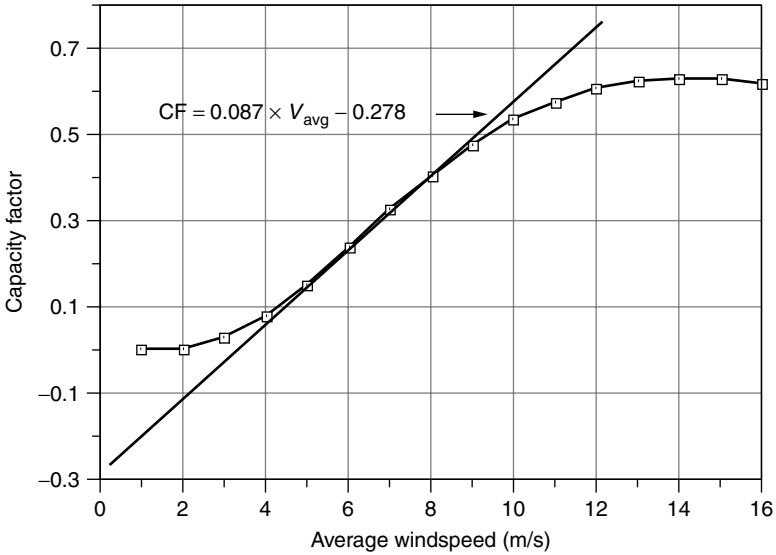

**Figure 6.39** A line fitted to the linear portion of the NEGMicon 1000/60 wind turbine.

That’s an interesting coincidence. For *this particular* wind turbine the y-axis intercept,  $b$ , equals  $P/D^2$  so we can write the capacity factor as

$$CF = 0.087\bar{V} - \frac{P_R}{D^2} \quad (\text{Rayleigh winds}) \quad (6.65)$$

where  $\bar{V}$  is the average windspeed (m/s),  $P_R$  is the rated power (kW), and  $D$  is the rotor diameter (m).

Surprisingly, even though the estimate in (6.65) was derived for a single turbine, it seems to work quite well in general as a predictor of capacity factor. For example, when applied to all eight of the wind turbines in Table 6.7, Eq. (6.65) correlates very well with the correct capacity factors computed using the spreadsheet approach (Fig. 6.40). In fact, in the range of capacity factors of most interest, 0.2 to 0.5, Eq. (6.65) is accurate to within 10% for those eight turbines. This simple CF relationship is very handy since it only requires the rated power and rotor diameter for the wind turbine, along with average windspeed.

Using (6.65) for capacity factor gives the following simple estimate of energy delivered from a turbine with diameter  $D$  (m), rated power  $P_R$  (kW) in Rayleigh winds with average windspeed  $\bar{V}$  (m/s)

$$\text{Annual energy (kWh/yr)} = 8760 \cdot P_R(\text{kW}) \left\{ 0.087\bar{V}(\text{m/s}) - \frac{P_R(\text{kW})}{[D(\text{m})]^2} \right\} \quad (6.66)$$

Of course, the spreadsheet approach has a solid theoretical basis and is the preferred method for determining annual energy, but (6.66) can be a handy one,



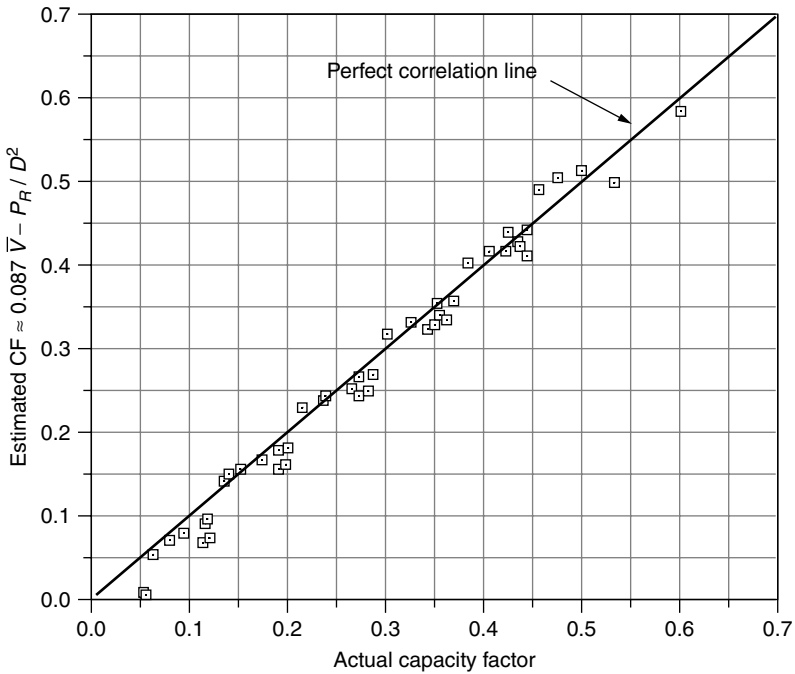

**Figure 6.40** Correlation between actual capacity factor (using the spreadsheet approach) and an estimate given by (6.65) for the eight wind turbines in Table 6.7.

especially when little data for the wind and turbine are known (Jacobson and Masters, 2001).

---

**Example 6.17 Energy Estimate Using the Capacity Factor Approach.** The Whisper H900 wind turbine has a 900-W generator with 2.13-m blades. In an area with 6-m/s average windspeeds, estimate the energy delivered.

**Solution.** Using (6.65) for capacity factor gives

$$CF = 0.087\bar{V} - \frac{P_R}{D^2} = 0.087 \times 6 - \frac{0.90}{2.13^2} = 0.324$$

The energy delivered in a year's time would be

$$\text{Energy} = 8760 \text{ h/yr} \times 0.90 \text{ kW} \times 0.324 = 2551 \text{ kWh/yr}$$

Of course, we could have done this just by plugging into (6.66).

For comparison, the spreadsheet approach yields an answer of 2695 kWh/yr, just 6% higher.

In these winds, this little wind turbine puts out about 225 kWh/mo—probably enough for a small, efficient household.

---

It is reassuring to note that the capacity factor relationship in (6.65), which was derived for a very large 1000-kW wind turbine with 60-m blades, gives quite accurate answers for a very small 0.90-kW turbine with 2.13-m blades.

The question sometimes arises as to whether or not a high-capacity factor is a good thing. A high-capacity factor means that the turbine is deriving much of its energy in the flat, wind-shedding region of the power curve above the rated windspeed. This means that power production is relatively stable, which can have some advantages in terms of the interface with the local grid. On the other hand, a high-capacity factor means that a significant fraction of the wind's energy is not being captured since the blades are purposely shedding much of the wind to protect the generator. It might be better to have a larger generator to capture those higher-speed winds, in which case the capacity factor goes down while the energy delivered increases. A bigger generator, of course, costs more. In other words, the capacity factor itself is not a good indicator of the overall economics for the wind plant.

## 6.11 WIND TURBINE ECONOMICS

Wind turbine economics have been changing rapidly as machines have gotten larger and more efficient and are located in sites with better wind. In Fig. 6.41, the average rated power of new Danish wind turbines by year of sale shows a steady rise from roughly 50 kW in the early 1980s to 1200 kW in 2002 (Denmark accounts for more than half of world sales). The biggest machines currently being built are in the 2000-kW to 3000-kW size range. More efficient machines located in better sites with higher hub heights have doubled the average energy productivity from around 600 kWh/yr per square meter of blade area 20 years ago to around 1200 kWh/m<sup>2</sup>-yr today.

### 6.11.1 Capital Costs and Annual Costs

While the rated power of new machines has increased year by year, the corresponding capital cost per kW dropped. As shown in Fig. 6.42, the capital cost of new installations has dropped from around \$1500/kW for 150-kW turbines in 1989 to about \$800/kW in 2000 for machines rated at 1650 kW. The impact of economies of scale is evident. The labor required to build a larger machine is not that much higher than for a smaller one; the cost of electronics are only moderately different; the cost of a rotor is roughly proportional to diameter while

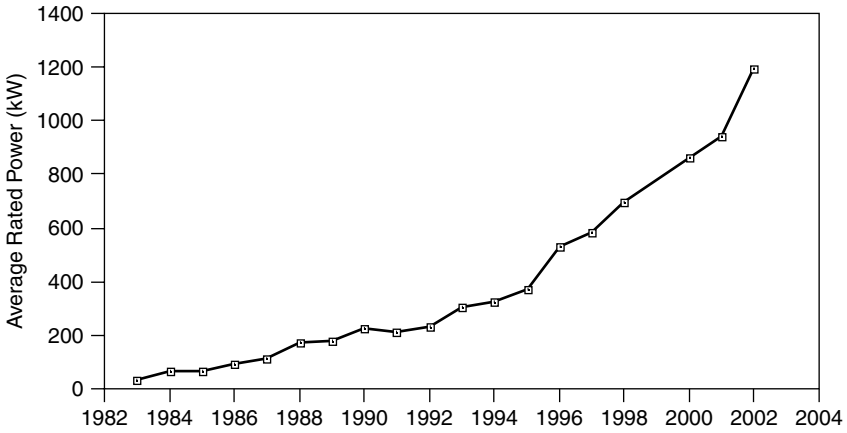

**Figure 6.41** Average rated power of new wind turbines manufactured in Denmark (www.windpower.dk).

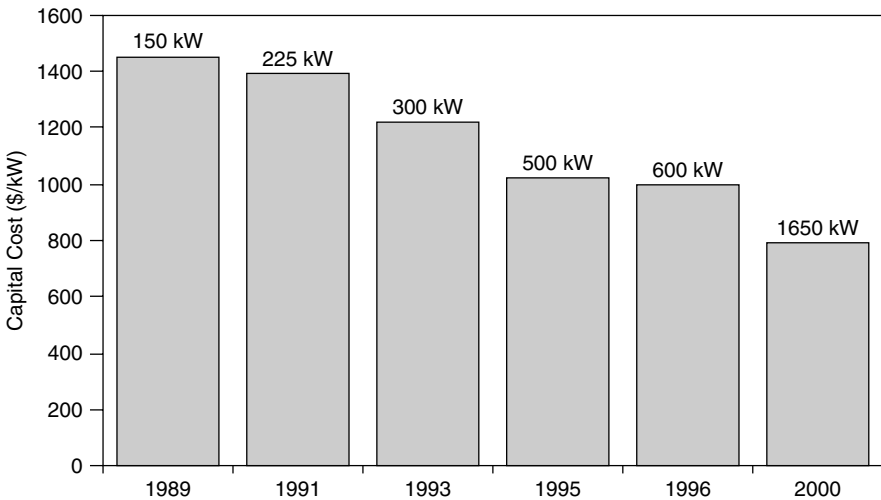

**Figure 6.42** Capital costs of wind systems including turbine, tower, grid connection, site preparation, controls, and land. The 2000 cost is based on a wind farm rather than a single turbine. From Redlinger (1999) and AWEA.

power delivered is proportional to diameter squared; taller towers increase energy faster than costs increase; and so forth.

An example cost analysis for a 60-MW wind farm consisting of forty 1.5-MW turbines is given in Table 6.8. Included in the table is a cost breakdown for the initial capital costs and an estimate of the levelized annual cost of operations and maintenance (O&M). About three-fourths of the capital cost is associated with

**TABLE 6.8 An Example Cost Analysis for a 60-MW Wind Park**

Capital Costs	Amount (\$)	Percentage
40 1.5-MW turbines @ \$1.1 M, spare parts	46,640,000	76.6
Site prep, grid connections	9,148,000	15.0
Interest during construction, contingencies	3,514,000	5.8
Project development, feasibility study	965,000	1.6
Engineering	611,000	1.0
Total Capital Cost	60,878,000	100.0
Annual Costs	Amount (\$/yr)	Percentage
Parts and labor	1,381,000	70.3
Insurance	135,000	6.9
Contingencies	100,000	5.1
Land lease	90,000	4.6
Property taxes	68,000	3.5
Transmission line maintenance	80,000	4.1
General and miscellaneous	111,000	5.6
Total Annual Costs	1,965,000	100.0

Source: Ministry of Natural Resources, Canada.

turbines, while the remaining portion covers costs related to turbine erection, grid connections, foundations, roads, and buildings. Operations and maintenance costs (O&M) include regular maintenance, repairs, stocking spare parts, insurance, land lease fees, insurance, and administration. Some of these are annual costs that don't particularly depend on the hours of operation of the wind turbines, such as insurance and administration, while others, those that involve wear and tear on parts, are directly related to annual energy produced. In this example, the annual O&M costs, which have already been levelized to include future cost escalations, are just over 3% of the initial capital cost of the wind farm.

In general, O&M costs depend not only on how much the machine is used in a given year, but also on the age of the turbine. That is, toward the end of the design life, more components will be subject to failure and maintenance will increase. Also, there are reasons to expect some economies of scale for O&M costs. A single turbine sitting somewhere will cost more to service than will a turbine located in a large wind park. Large turbines will also cost less to service, per kW of rated power, than a small one since labor costs will probably be comparable. Larger turbines are also newer-generation machines that have better components and designs to minimize the need for repairs.

### 6.11.2 Annualized Cost of Electricity from Wind Turbines

To find a levelized cost estimate for energy delivered by a wind turbine, we need to divide annual costs by annual energy delivered. To find annual costs, we must

spread the capital cost out over the projected lifetime using an appropriate factor and then add in an estimate of annual O&M. Chapter 5 developed a number of techniques for doing such calculations, but let's illustrate one of the simpler approaches here.

To the extent that a wind project is financed by debt, we can annualize the capital costs using an appropriate capital recovery factor (CRF) that depends on the interest rate  $i$  and loan term  $n$ . The annual payments  $A$  on such a loan would be

$$A = P \cdot \left[ \frac{i(1+i)^n}{(1+i)^n - 1} \right] = P \cdot \text{CRF}(i, n) \quad (6.67)$$

where  $A$  represents annual payments (\$/yr),  $P$  is the principal borrowed (\$),  $i$  is the interest rate (decimal fraction; e.g., 0.10 for a 10% interest rate),  $n$  is the loan term (yrs), and

$$\text{CRF}(i, n) = \frac{i(1+i)^n}{(1+i)^n - 1} \quad (6.68)$$

A handy table of values for  $\text{CRF}(i, n)$  is given in Table 5.5.

---

**Example 6.18 A Loan to Pay for a Small Wind Turbine.** Suppose that a 900-W Whisper H900 wind turbine with 7-ft diameter (2.13 m) blade costs \$1600. By the time the system is installed and operational, it costs a total of \$2500, which is to be paid for with a 15-yr, 7 percent loan. Assuming O&M costs of \$100/yr, estimate the cost per kWhr over the 15-year period if average windspeed at hub height is 15 mph (6.7 m/s).

**Solution.** The capital recovery factor for a 7%, 15-yr loan would be

$$\text{CRF}(0.07, 15 \text{ yr}) = \frac{i(1+i)^n}{(1+i)^n - 1} = \frac{0.07(1+0.07)^{15}}{(1+0.07)^{15} - 1} = 0.1098/\text{yr}$$

which agrees with Table 5.5. So, the annual payments on the loan would be

$$A = P \times \text{CRF}(0.07, 15) = \$2500 \times 0.1098/\text{yr} = \$274.49/\text{yr}$$

The annual cost, including \$100/yr of O&M, is therefore  $\$274.49 + \$100 = \$374.49$ .

To estimate energy delivered by this machine in 6.7-m/s average wind, let us use the capacity factor approach (6.65):

$$\text{CF} = 0.087\bar{V}(\text{m/s}) - \frac{P_R(\text{kW})}{D^2(\text{m}^2)} = 0.087 \times 6.7 - \frac{0.90}{2.13^2} = 0.385$$

The annual energy delivered (6.59)

$$\text{kWh/yr} = 0.90 \text{ kW} \times 8760 \text{ h/yr} \times 0.385 = 3035 \text{ kWh/yr}$$

The average cost per kWh is therefore

$$\text{Average cost} = \frac{\text{Annual cost (\$/yr)}}{\text{Annual energy (kWh/yr)}} = \frac{\$374.49/\text{yr}}{3035 \text{ kWh/yr}} = \$0.123/\text{kWh}$$

That's a pretty good price of electricity for a small system—cheaper than grid electricity in many areas and certainly cheaper than any other off-grid, home-size generating system.

---

A sensitivity analysis of the cost of electricity from a 1500-kW, 64-m turbine, with a levelized O&M cost equal to 3% of capital costs, financed with a 7%, 20-year loan, is shown in Fig. 6.43. Again, taxes, depreciation, and the production tax credit are not included.

For large wind systems, capital costs are often divided into an equity portion, which comes out of the financial resources of the owner and must earn an appropriate annual rate of return, plus a debt portion that is borrowed over a loan term

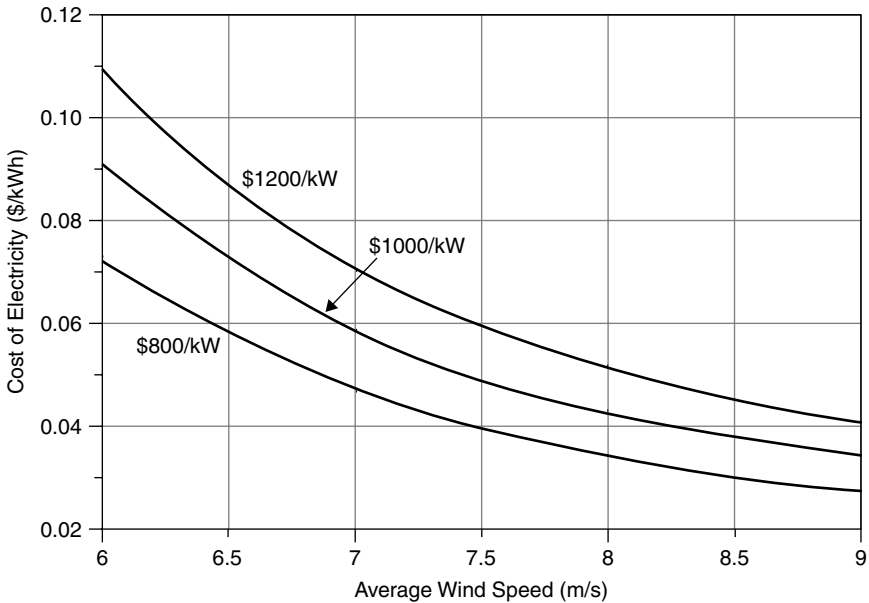

**Figure 6.43** Sensitivity analysis of the levelized cost of a 1500-kW, 64-m wind turbine using (6.65) for capacity factor. Levelized O&M is 3% of capital cost, financing is 7%, 20 years. Depreciation, taxes, and government incentives are not included in this analysis.

at some interest rate. The price of electricity sold by the project must recover both the debt and equity portions of the financing.

---

**Example 6.19 Price of Electricity from a Wind Farm.** A wind farm project has 40 1500-kW turbines with 64-m blades. Capital costs are \$60 million and the levelized O&M cost is \$1.8 million/yr. The project will be financed with a \$45 million, 20-yr loan at 7% plus an equity investment of \$15 million that needs a 15% return. Turbines are exposed to Rayleigh winds averaging 8.5 m/s. What levelized price would the electricity have to sell for to make the project viable?

**Solution.** We can estimate the annual energy that will be delivered by starting with the capacity factor, (6.65):

$$CF = 0.087\bar{V} \text{ (m/s)} - \frac{P_R(\text{kW})}{[D(\text{m})]^2} = 0.087 \times 8.5 - \frac{1500}{64^2} = 0.373$$

For 40 such turbines, the annual electrical production will be

$$\begin{aligned} \text{Annual energy} &= 40 \text{ turbines} \times 1500 \text{ kW} \times 8760 \text{ h/yr} \times 0.373 \\ &= 196 \times 10^6 \text{ kWh/yr} \end{aligned}$$

The debt payments will be

$$\begin{aligned} A &= P \cdot \left[ \frac{i(1+i)^n}{(1+i)^n - 1} \right] = \$45,000,000 \cdot \left[ \frac{0.07(1+0.07)^{20}}{(1+0.07)^{20} - 1} \right] \\ &= \$4.24 \times 10^6/\text{yr} \end{aligned}$$

The annual return on equity needs to be

$$\text{Equity} = 0.15/\text{yr} \times \$15,000,000 = \$2.25 \times 10^6/\text{yr}$$

The levelized O&M cost is \$1.8 million, so the total for O&M, debt, and equity is

$$\text{Annual cost} = (\$4.24 + 2.25 + 1.8) \times 10^6 = \$8.29 \times 10^6/\text{yr}$$

The levelized price at which electricity needs to be sold is therefore

$$\text{Selling price} = \frac{\$8.29 \times 10^6/\text{yr}}{196 \times 10^6 \text{ kWh/yr}} = \$0.0423 = 4.23\text{¢/kWh}$$

---

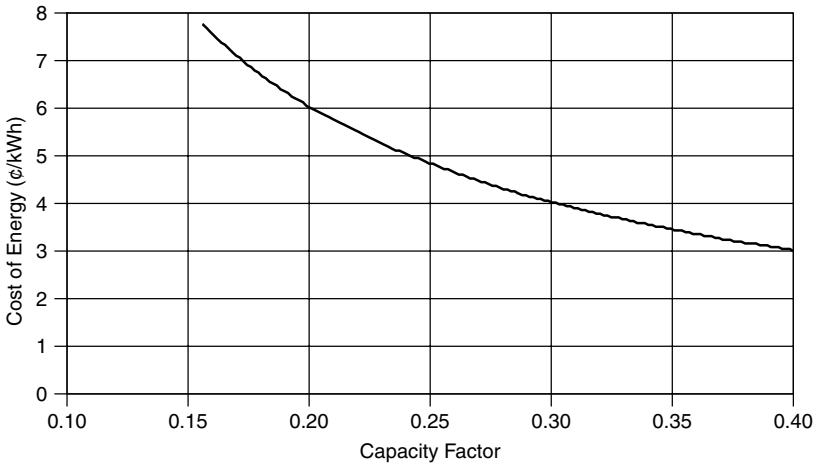

**Figure 6.44** Cost of energy from a \$1000/ kW, 50-MW windfarm including PTC, depreciation, financing charges, and tax implications (O&M 1¢/kWh, inflation 2.3%, 60% equity with return 15%, debt interest 5%, income tax rate 40.7%, PTC 1.8¢/kWh for 10 yrs, CEC 5-yr incentive 0.75/kWh, discount rate 5%, MACRS 5-yr depreciation, property taxes 1.1%). Based on Bolinger et al. (2001).

Example 6.19 leaves out a number of other factors that affect the economic viability of doing the wind farm, including depreciation, income taxes, and a special tax incentive called the wind energy *production tax credit* (PTC). The production tax credit enacted in 1992 provides a 10-year, 1.5¢/kWh tax credit for electricity produced by wind energy systems installed by a certain date (inflation adjustable). The credit has been a mixed blessing to the wind industry. While it does provide a significant financial incentive, it has also caused a boom and bust cycle in the wind industry because the final deadline for projects to receive the credit is renewable at the pleasure of Congress. For example, when the credit expired in 1999, new installed capacity in the United States dropped from 661 MW in 1999 to only 53 MW in 2000. Then when it was renewed, installations jumped to 1696 MW in 2001, at which point it expired again, and in 2002 new wind power installations dropped back to 410 MW.

A careful analysis including PTC, equity and debt financing, depreciation, and inflation for a \$1000/ kW, 50-MW windfarm with a 0.30 capacity factor yields a cost of wind power of 4.03¢/kWh (Bolinger et al. (2001)). Scaling that result for varying capacity factors yields the graph shown in Fig. 6.44.

## 6.12 ENVIRONMENTAL IMPACTS OF WIND TURBINES

Wind systems have negative as well as positive impacts on the environment. The negative ones relate to bird kills, noise, construction disturbances, aesthetic impacts, and pollution associated with manufacturing and installing the turbine. The positive impacts result from wind displacing other, more polluting energy systems.



Birds do collide with wind turbines, just as they collide with cars, cell-phone towers, glass windows, and high-voltage power lines. While the rate of deaths caused by wind turbines is miniscule compared to these other obstacles that humans put into their way, it is still an issue that can cause concern. Early wind farms had small turbines with fast-spinning blades and bird kills were more common but modern large turbines spin so slowly that birds now more easily avoid them. A number of European studies have concluded that birds almost always modify their flight paths well in advance of encountering a turbine, and very few deaths are reported. Studies of eider birds and offshore wind parks in Denmark concluded that the eiders avoided the turbines even when decoys to attract them were placed nearby. They also noted no change in the abundance of nearby eiders when turbines were purposely shut down to study their behavior.

People's perceptions of the aesthetics of wind farms are important in siting the machines. A few simple considerations have emerged, which can make them much more acceptable. Arranging same-size turbines in simple, uniform rows and columns seems to help, as does painting them a light gray color to blend with the sky. Larger turbines rotate more slowly, which makes them somewhat less distracting.

Noise from a wind turbine or a wind farm is another potentially objectionable phenomenon, and modern turbines have been designed specifically to control that noise. It is difficult to actually measure the sound level caused by turbines in the field because the ambient noise caused by the wind itself masks their noise. At a distance of only a few rotor diameters away from a turbine, the sound level is comparable to a person whispering.

The air quality advantages of wind are pretty obvious. Other than the very modest imbedded energy, wind systems emit none of the  $SO_x$ ,  $NO_x$ , CO, VOCs, or particulate matter associated with fuel-fired energy systems. And, of course, since there are virtually no greenhouse gas emissions, wind economics will get a boost if and when carbon emitting sources begin to be taxed.

## REFERENCES

- Bolinger, M., R. Wiser, and W. Golove (2001). *Revisiting the "Buy versus Build" Decision for Publicly Owned Utilities in California Considering Wind and Geothermal Resources*, Lawrence Berkeley National Labs, LBNL 48831, October.
- Cavallo, A. J., S. M. Hock, and D. R. Smith (1993). Wind Energy: Technology and Economics. Chapter 3 in *Renewable Energy, Sources for Fuels and Electricity*, L. Burnham, ed., Island Press, Washington, D.C.
- Elliot, D. L., C. G. Holladay, W. R. Barchett, H. P. Foote, and W. F. Sandusky (1987). *Wind Energy Resource Atlas of the United States*, Solar Energy Research Institute, U.S. Department of Energy, DOE/CH 100934, Golden, CO.
- Elliot, D. L., L. L. Windell, and G. I. Gower (1991). *An Assessment of the Available Windy Land Area and Wind Energy Potential in the Contiguous United States*, Pacific Northwest Laboratory, PNL-7789, August.

Grubb, M. J., and N. I. Meyer (1993). Wind Energy: Resources, Systems, and Regional Strategies. Chapter 4 in *Renewable Energy: Sources for Fuels and Electricity*, Island Press, Washington, D.C.

Jacobson, M. Z., and G. M. Masters (2001). Exploiting Wind Versus Coal, *Science*, 24 August, vol. 293, p. 1438.

Johnson, G. L. (1985). *Wind Energy Systems*, Prentice-Hall, Englewood Cliffs, N.J.

Krohn, S. (1997). The Energy Balance of Modern Wind Turbines, *Wind Power Note*, #10, December. Vindmølleindustrien, Denmark (available at www.windpower.dk).

Milborrow, D. J., and P. L. Surman (1987). Status of wake and array loss research. AWEA Windpower 91 Conference, Palm Springs, CA.

Pacific Northwest Laboratory (1991). *An Assessment of the Available Windy Land Area and Wind Energy Potential in the Contiguous United States*.

Patel, M. K. (1999). *Wind and Solar Power Systems*, CRC Press, New York.

Redlinger, R. Y., P. D. Andersen, and P. E. Morthorst (1999). *Wind Energy in the 21st Century*, Macmillan Press, London.

Troen, I., and E. L. Petersen (1991). *European Wind Atlas*, Risoe National Laboratory, Denmark.

**PROBLEMS**

- 6.1** A horizontal-axis wind turbine with rotor 20 meters in diameter is 30-% efficient in 10 m/s winds at 1 atmosphere of pressure and 15°C.
- How much power would it produce in those winds?
  - Estimate the air density on a 2500-m mountaintop at 10°C.
  - Estimate the power the turbine would produce on that mountain with the same windspeed assuming its efficiency is not affected by air density.
- 6.2.** An anemometer mounted at a height of 10 m above a surface with crops, hedges and shrubs, shows a windspeed of 5 m/s. Assuming 15°C and 1 atm pressure, determine the following for a wind turbine with hub height 60 m and rotor diameter of 60 m:

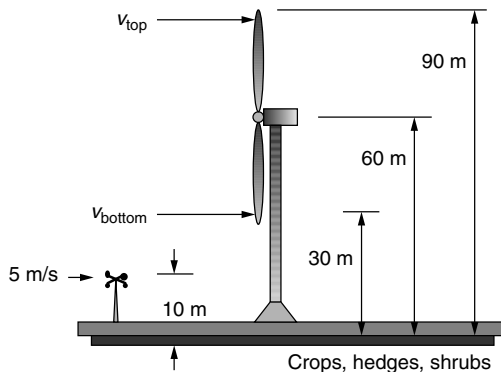

**Figure P6.2**

- a. Estimate the windspeed and the specific power in the wind ( $\text{W/m}^2$ ) at the highest point that a rotor blade reaches.
- b. Repeat (a) at the lowest point at which the blade falls.
- c. Compare the ratio of wind power at the two elevations using results of (a) and (b) and compare that with the ratio obtained using (6.17).

6.3 Consider the following probability density function for wind speed:

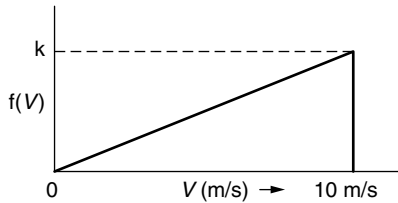

Figure P6.3

- a. What is an appropriate value of  $k$  for this to be a legitimate probability density function?
  - b. What is the average power in these winds ( $\text{W/m}^2$ ) under standard ( $15^\circ\text{C}$ , 1 atm) conditions?
- 6.4 Suppose the wind probability density function is just a constant over the 5 to 20 m/s range of windspeeds, as shown below. The power curve for a small 1 kW windmill is also shown.

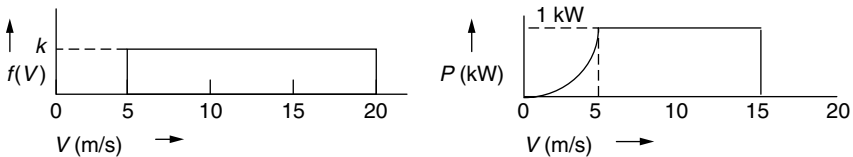

Figure P6.4

- a. What is the probability that the wind is blowing between 5 and 15 m/s?
  - b. What is the annual energy that the wind turbine would generate?
  - c. What is the average power in the wind?
- 6.5 Suppose an anemometer mounted at a height of 10-m on a level field with tall grass shows an average windspeed of 6 m/s.
- a. Assuming Rayleigh statistics and standard conditions ( $15^\circ\text{C}$ , 1 atm), estimate the average wind power ( $\text{W/m}^2$ ) at a height of 80 m.
  - b. Suppose a 1300-kW wind turbine with 60-m rotor diameter is located in those 80 m winds. Estimate the annual energy delivered (kWh/yr) if you assume the turbine has an overall efficiency of 30%.
  - c. What would the turbine's capacity factor be?

- 6.6** In the derivation of the cumulative distribution function,  $F(V)$  for a Weibull function we had to solve the integral  $F(V) = \int_0^V f(v) dv$ . Show that  $F(V)$  in (6.53) is the correct result by taking the derivative  $f(v) = \frac{dF(V)}{dV}$  and seeing whether you get back to the Weibull probability density function given in (6.41).
- 6.7** The table below shows a portion of a spreadsheet that estimates the energy delivered by a NEG Micon 1000 kW/60 m wind turbine exposed to Rayleigh winds with an average speed of 8 m/s.

$v$ (m/s)	kW	kWh/yr
0	0	0
1	0	0
2	0	0
3	0	0
4	33	23,321
5	86	?
6	...	...
etc.		

- a. How many kWh/yr would be generated with 5 m/s winds?
  - b. Using Table 6.7, how many kWh/yr would be generated in 10 m/s winds for a Vestas 600/42 machine?
- 6.8** Consider the Nordex 1.3 MW, 60-m wind turbine with power specifications given in Table 6.7 located in an area with 8 m/s average wind speeds.
- a. Find the average power in the wind ( $W/m^2$ ) assuming Rayleigh statistics.
  - b. Create a spreadsheet similar to the one developed in Example 6.15 to determine the energy delivered (kWh/yr) from this machine.
  - c. What would be the average efficiency of the wind turbine?
  - d. If the turbine's rotor operates at 70% of the Betz limit, what is the efficiency of the gearing and generator?
- 6.9** For the following turbines and average Rayleigh wind speeds, set up a spreadsheet to find the total annual kWh delivered and compare that with an estimate obtained using the simple correlation given in (6.65):
- a. Bonus 300 kW/33.4 m, 7 m/s average wind speed
  - b. NEG/Micon 1000 kW/60 m, 8 m/s average wind speed
  - c. Vestas 600 kW/42 m, 8 m/s average wind speed
  - d. Whisper 0.9 kW/2.13 m, 5 m/s average wind speed
- 6.10** Consider the design of a home-built wind turbine using a 350-W automobile dc generator. The goal is to deliver 70 kWh in a 30-day month.

- a. What capacity factor would be needed for the machine?
  - b. If the average wind speed is 5 m/s, and Rayleigh statistics apply, what should the rotor diameter be if the correlation of (6.65) is used?
  - c. How fast would the wind have to blow to cause the turbine to put out its full 0.35 kW if the machine is 20% efficient at that point?
  - d. If the tip-speed-ratio is assumed to be 4, what gear ratio would be needed to match the rotor speed to the generator if the generator needs to turn at 1000 rpm to deliver its rated 350 W?
- 6.11** A 750-kW wind turbine with 45-m blade diameter operates in a wind regime that is well characterized by Rayleigh statistics with average windspeed equal to 7 m/s.

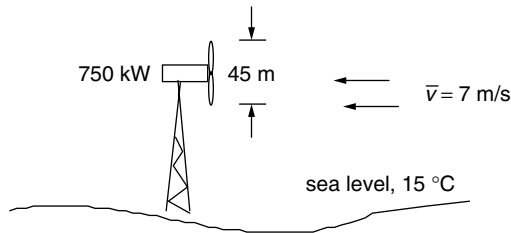

**Figure P6.11**

- Assuming the capacity factor correlation (6.65), what is the average efficiency of this machine?
- a. How many hours per year do the winds blow at less than 13 m/s?
  - b. For how many hours per year are windspeeds above 25 m/s?
  - c. Suppose a 31-m, 340-kW turbine follows the idealized power curve shown in Figure 6.32. How many kWh/yr will it deliver when winds blow between its rated windspeed of 13 m/s and its furling windspeed of 25 m/s?
  - d. Using the capacity factor correlation given in (6.65), estimate the fraction of the annual energy delivered with winds that are above the rated windspeed?
- 6.13** Using the simple capacity factor correlation, derive an expression for the average (Rayleigh) windspeed that yields the highest efficiency for a turbine as a function of its rated power and blade diameter. What is the optimum windspeed for
- a. The NEG/Micon 1000 kW/60 m turbine
  - b. The NEG/Micon 1000 kW/54 m turbine?
- 6.14** Consider a 64-m, 1.5 MW NEG Micon wind turbine (Table 6.7) located at a site with Rayleigh winds averaging 7.5 m/s.

- a. Using the simple capacity factor correlation (6.65) estimate the annual energy delivered.
- b. Suppose the total installed cost of the wind turbine is \$1.5 million (\$1/watt) and its annual cost is based on the equivalent of a 20-year, 6% loan to cover the capital costs. In addition, assume an annual operations and maintenance cost equal to 1-% of the capital cost. What would be the cost of electricity from this turbine (¢/kWh)?
- c. If farmers are paid 0.1 ¢/kWh to put these towers on their land, what would their annual royalty payment be per turbine?
- d. If turbines are installed with a density corresponding to  $4D \times 7D$  separations (where  $D$  is rotor diameter), what would the annual payment be per acre?

**6.15** This question has 4 different combinations of turbine, average wind speed, capital costs, return on equity, loan terms, and O&M costs. Using the capacity factor correlation, find their levelized costs of electricity.

	(a)	(b)	(c)	(d)
Turbine power (kW)	1500	600	250	1000
Rotor diameter (m)	64	42	29.2	60
Avg wind speed (m/s)	8.5	8.5	8.5	8.5
Capital cost (\$/kW)	800	1000	1200	900
Equity % of capital	25	25	25	25
Annual return on equity (%)	15	15	15	15
Loan interest (%)	7	7	7	7
Loan term (yrs)	20	20	20	20
Annual O&M percent of capital	3	3	3	3

