

Renewable Energy for Sustainable Rural Village Power

Jonathan O.V. Touryan
Kenell J. Touryan

*Presented at the American Scientific Affiliation
Conference
Arkansas
August 1, 1999*



NREL

National Renewable Energy Laboratory

1617 Cole Boulevard
Golden, Colorado 80401-3393

NREL is a U.S. Department of Energy Laboratory
Operated by Midwest Research Institute • Battelle • Bechtel

Contract No. DE-AC36-98-GO10337

NOTICE

This report was prepared as an account of work sponsored by an agency of the United States government. Neither the United States government nor any agency thereof, nor any of their employees, makes any warranty, express or implied, or assumes any legal liability or responsibility for the accuracy, completeness, or usefulness of any information, apparatus, product, or process disclosed, or represents that its use would not infringe privately owned rights. Reference herein to any specific commercial product, process, or service by trade name, trademark, manufacturer, or otherwise does not necessarily constitute or imply its endorsement, recommendation, or favoring by the United States government or any agency thereof. The views and opinions of authors expressed herein do not necessarily state or reflect those of the United States government or any agency thereof.

Available to DOE and DOE contractors from:
Office of Scientific and Technical Information (OSTI)
P.O. Box 62
Oak Ridge, TN 37831
Prices available by calling 423-576-8401

Available to the public from:
National Technical Information Service (NTIS)
U.S. Department of Commerce
5285 Port Royal Road
Springfield, VA 22161
703-605-6000 or 800-553-6847
or
DOE Information Bridge
<http://www.doe.gov/bridge/home.html>



RENEWABLE ENERGY FOR SUSTAINABLE RURAL VILLAGE POWER

Jonathan O.V. Touryan*

Kenell J. Touryan**

National Renewable Energy Laboratory, Golden, CO 80401

It is estimated that two billion people live without electricity and its services worldwide. In addition, there is a sizeable number of rural villages that have limited electrical service, with either part-day operation by diesel generator or partial electrification. For many villages connected to the grid, power is often sporadically available and of poor quality. The United States National Renewable Energy Laboratory (NREL) in Golden, Colorado, has initiated a program that involves hybrid systems, to address these potential electricity opportunities in rural villages through the application of renewable energy technologies.¹ The objective of this program is to develop and implement applications that demonstrate the technical performance, economic competitiveness, operational viability, and environmental benefits of renewable rural electric solutions, compared to the conventional options of line extension and isolated diesel mini-grids. Hybrid systems are multi-disciplinary, multi-technology, multi-application programs composed of six activities, including village applications development, computer model development, systems analysis, pilot project development, technical assistance, and Internet-based village power project data base. While the current program emphasizes wind, photovoltaics (PV), and their hybrids with diesel generator, micro-hydro and micro-biomass technologies may be integrated in the future. Thirteen countries are actively engaged in hybrid systems for rural and remote applications and another dozen countries have requested assistance in exploring wind/PV hybrid systems within their territories. At present rural/remote site application of renewable technologies is the fastest growing aspect of renewable energy worldwide.

A. The Hybrid System and Practical Applications

The main objective of the applications development activities using hybrid systems is to investigate renewable energy-based systems that will reduce the life-cycle cost and/or improve the performance of commercial renewable energy systems, thereby expanding the market for renewables. Many of these applications have the potential to facilitate economic development within the village; a major goal of many international development organizations and host-country national and provincial governments. Electrification of rural villages has the potential to initiate substantial development activities, if electric power were available during daytime hours, and appropriate training and marketing infrastructure were available to villages. However, in most smaller villages served by diesel generators, it is cost-prohibitive to provide daytime power and, therefore the economic development potential of these villages cannot be realized. Renewable energy systems are better suited to deliver 24-hr power in small villages (less than 2000 inhabitants) where income generation and economic developments are being pursued as policy goals.

The energy needs of *households* are towards cooking, lighting, space-heating, and the operation of household appliances and devices. Traditional energy sources form the bulk of energy supply for rural households.

Agricultural mechanisation involves mainly the use of diesel for tractors, tillers, threshers and other farm equipment, and the use of electricity in irrigation pump-sets. The numbers of these equipment are on the increase in all countries. However, this has no effect upon the extent of traditional energy consumption in the

*Engineer, International Hybrid Power Group.

**Team Leader, Technology Transfer Deployment Support Center.

sector since, as stated earlier, the energy source substituted is human or animal labour. Diesel is also a major fuel for irrigation pump-sets in unelectrified villages.

The energy needs of rural *industries* comprise lighting, process heat and motive power requirements. Lighting requirements are invariably met by electricity in electrified villages and by kerosene in unelectrified villages. The principal supply sources for process heat in facilities such as blacksmithy, brick-making and charcoal manufacture are fuelwood and biomass. Motive power requirements are met by electricity, where it is available, and by human labour using mechanical equipment, where electricity is not available. In agro-based facilities, such as crop-drying and rice-milling, the use of biomass is widespread.

Hybrid systems are being considered for ice-making, water desalination, water purification, battery-charging stations, and village hybrid power generation. Because many villages have either diesels dedicated to a particular use or a diesel mini-grid, they face both economic (fuel cost) and maintenance problems associated with remote diesel operations. Yet in many of these villages, the solar and/or wind resources are good enough to compete economically with the life-cycle cost of diesel operation.

B. System Design

Hybrid systems can be powered by any combination of wind, photovoltaics, diesel, and batteries. Figure 1 shows a schematic of a hybrid system. Not all systems have all the components shown. In general, PV panels, small wind turbines, and batteries are all DC devices. If AC power is desired, the DC power must be converted to AC. Generators normally produce AC power, but some models also produce DC power. The components of a hybrid system fall into one of four categories. *Energy Generation*: Wind turbines and engines use generators to convert mechanical motion into electricity. PV panels convert sunlight directly into electricity. *Energy Storage*: These devices store energy and release it when it is needed. Energy storage often improves both the performance and economics of the system. The most common energy storage device used in hybrid system is the battery. *Energy Conversion*: In hybrid systems, energy conversion refers to converting AC electricity to DC or vice versa. A variety of equipment can be used to do this. Inverters convert DC to AC. Rectifiers convert AC to DC. Bi-directional inverters combine the functions of both invertors and rectifiers. *Balance of System (BOS)*: BOS items include monitoring equipment, a dump load (a device that sheds excess energy produced by the system), and the wiring and hardware needed to complete the system. This level of flexibility has obvious advantages for customizing a system for particular sites resources, costs, and load requirements. The flexibility, however, makes the design process more difficult. It is essential, therefore, to develop design models that can address (1) optimization of a hybrid configuration; (2) the technical and economic performance of hybrids; and (3) the economics of alternative village electricity options. Two such models have been developed. One is called Homer² and the other Hybrid-2.³ Both are being validated with operational data from the field, and are being used to design systems in rural settings, worldwide.

Briefly, Homer is an optimization model that takes into consideration hourly and seasonal variations in the village loads and resources, simple performance characterizations of each component, equipment costs, reliability requirements, and other site specific information. Homer identifies the optimal configuration as well as its sensitivity to user specified ranges of input parameters, for screening purposes. In addition to the configuration, Homer outputs include hourly energy flows through each component, the impact of several simple load management strategies, and economic information such as the cost of energy and net present

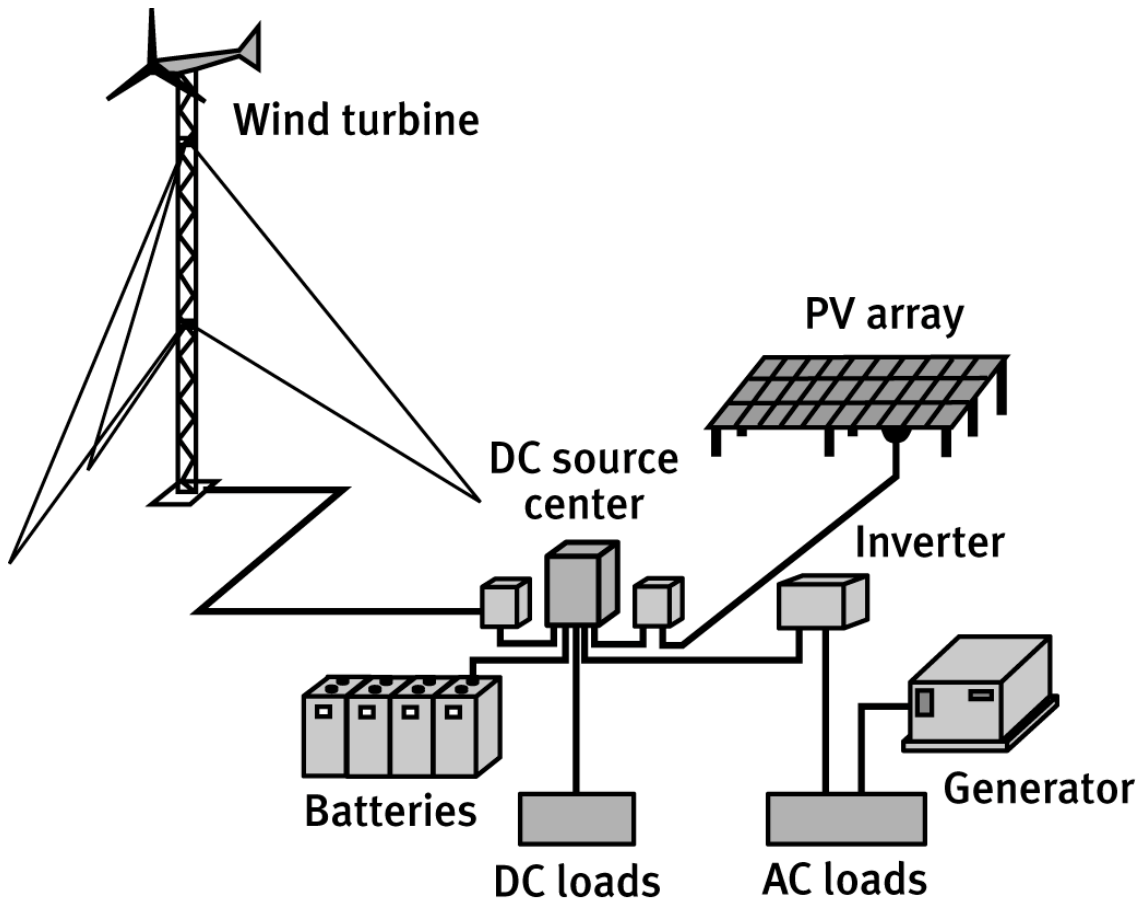

02523307m

Wind/PV/Diesel Hybrid System

Figure 1. Hybrid System Configuraton: Generalized hybrid system configuration showing energy storage components (phtovoltaic, wind turbine, and generator), energy storage components (batteries), energy conversion components (inverter), and balance of system components (direct current source center and charge controller). Courtesy of Bergey Wind Company.

costs of the system. Figure 2 illustrates such a screening analysis for a given wind site. Hybrid-2, on the other hand, is a software that employs a time-series/probabilistic model that uses time-series resource and load information, combined with statistical analysis, and manufacturers' data for hybrid system equipment to accurately predict the performance and cost of hybrid power systems. Hybrid-2 allows for the direct comparison of many different renewable and non-renewable power system designs.

Both Homer and Hybrid-2 require as one of their key inputs, *resource data*. Most potential sites lack sufficient information on solar insolation and/or wind speed, frequency and direction. Automated wind and solar insolation mapping techniques are now available that use the Geographic Information Systems (GIS) software. For wind, for example, this provides topographical data that is used as inputs for a computerized mapping technique. A variety of meteorological and other geographical data sets are used to support wind

HOMER

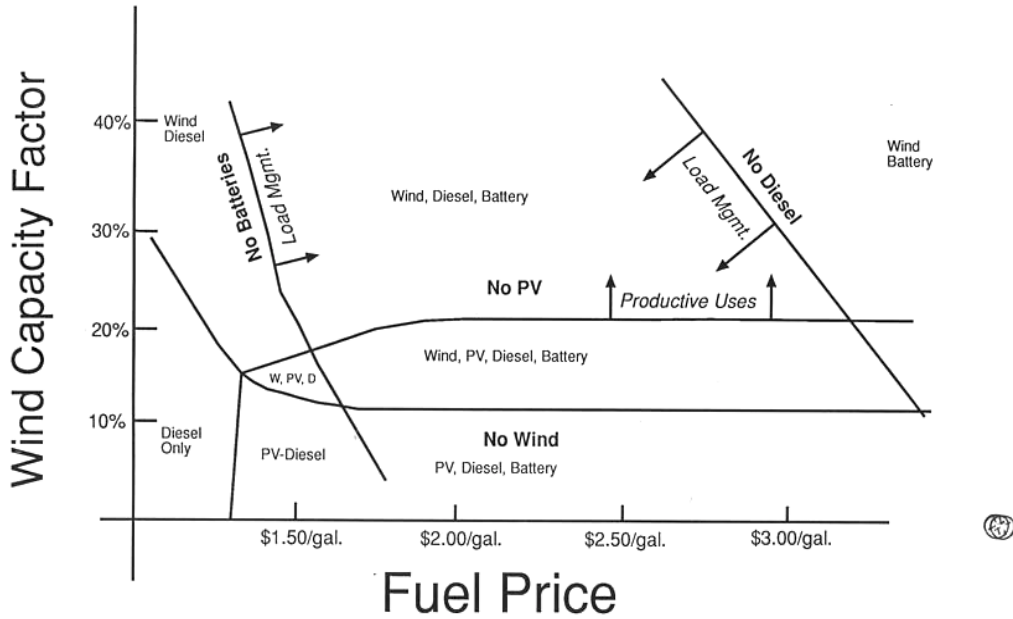

Figure 2. Typical wind/diesel/battery configuration analysis using HOMER code.

mapping projects. This computer mapping system⁴ uses an analytical approach and is designed to portray the distribution of the wind resources over a large area. These maps are then used to identify and target areas for possible sites and more detailed wind measurement projects.

C. Design Considerations and Economics

The main considerations driving a hybrid system selection are load, resource, costs (component, fuel, operating), and quality of service. Antonio Jimenez and Ken Olsen⁵ have prepared two graphs that show the least-cost configuration for two different-sized, typical health facilities as a function of average speed and average daily solar insolation. We reproduce their graphics. The costs given in these graphs are the annualized cost (\$/year) of the lowest cost system with the given solar and wind resources. The results assume a particular set of economic assumptions. The same set of wind speed and insolation data was used for all runs and scaled to get the various annual average values shown. The results are meant to show general trends only. PV = photovoltaics, WTG = wind turbine generator.

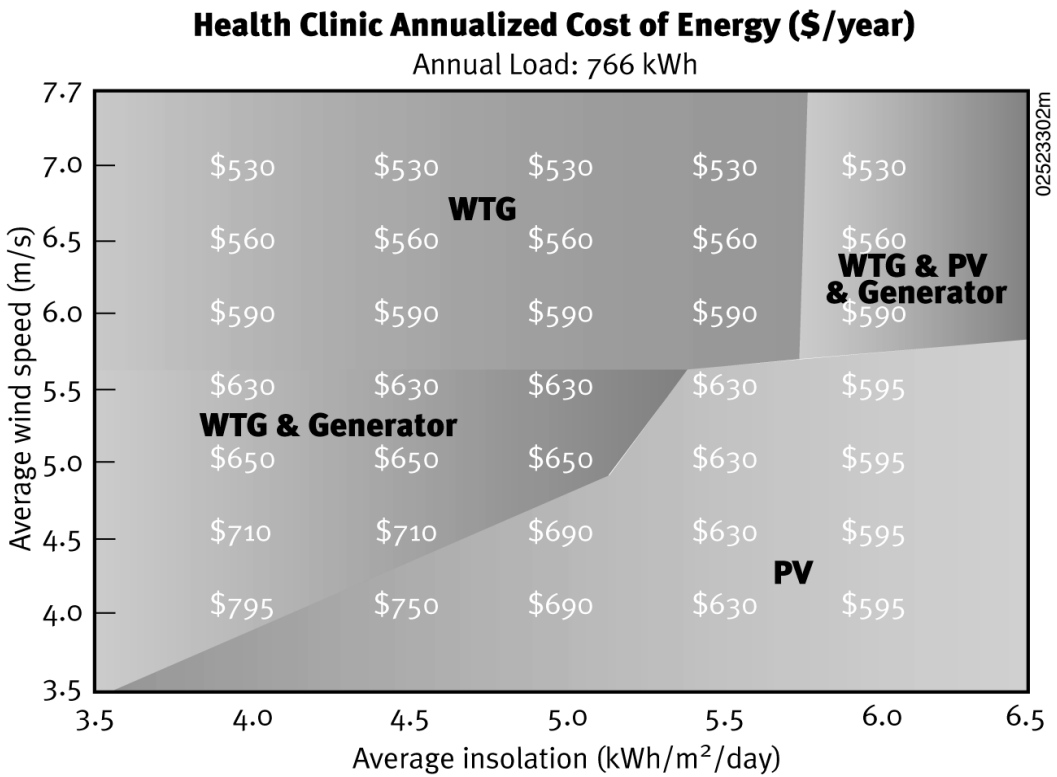
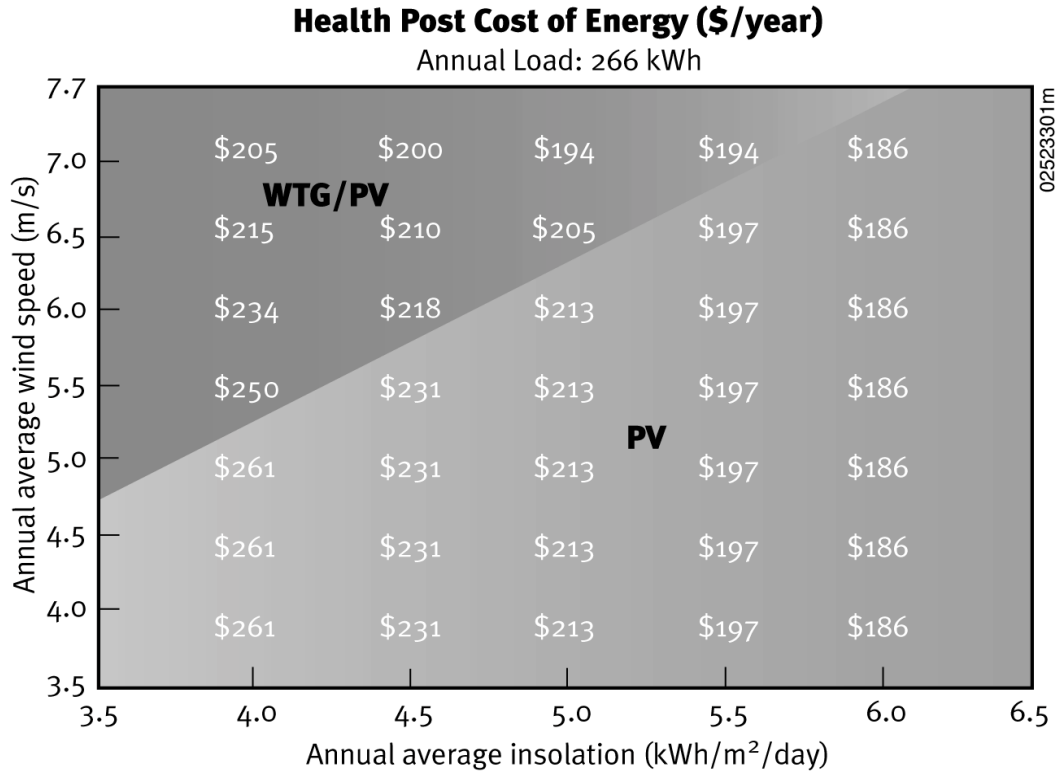

Figure 3. These graphs show the least-cost configurations for two different-sized health facilities as a function of average wind speed and average daily solar insolation.

D. A Case Study

Alaska has approximately 250 rural villages that have no link to the central power grids serving the main urban areas. The majority of these villages are served by diesel-driven generators. Because of the extreme remoteness of most of the rural villages, and the lack of roads, the delivered cost of diesel fuel is high, ranging from \$0.80 to \$3.00 per gallon. The high operation and maintenance costs of diesel generating stations result in electric generation costs that range from \$0.15 to \$1.00 per kWh. There are also significant environmental hazards associated with diesel power generation, including fuel spills during transport, leaky bulk fuel tanks in the villages, and CO₂ and other emissions.

To reduce the cost of rural power generation and the environmental impact of diesel fuel usage, the Alaska Department of Community and Regional Affairs - Division of Energy (DCRA/DOE), in collaboration with Kotzebue Electric Association (a rural Alaskan electric utility) and NREL, is developing wind-diesel hybrid power technology to be implemented in a pilot project in the village of Wales, Alaska, a native village of 160 people in northwest Alaska. The project integrates three 65-kW wind turbines into the existing Wales diesel power system (75-kW average load). The system incorporates reactive power and dump load control to provide regulation of line voltage and frequency, enabling the diesel gensets to be shut down during periods of high wind. The system also incorporates short term energy storage to prevent unnecessary diesel starts and maximize fuel savings .

Figure 4 gives the schematic layout of the Wales wind-diesel system (also see Ref. 6). A few important facts should be noted. A high penetration wind-diesel system requires controls, and one of the first steps in system installation is to retrofit all diesels with controls making them capable of automatic starting, stopping, synchronization, and load sharing. Energy storage using a battery bank is necessary to meet the average load for the system for about 10-minutes. This will avoid excessive wear and tear on diesels whenever there is a transient wind power drop that could cause the load to exceed the available wind power. Figure 5 illustrates the fuel savings potential and the reduction in cost of energy, as a function of average wind speed for the above configuration (levelized over 30 years).

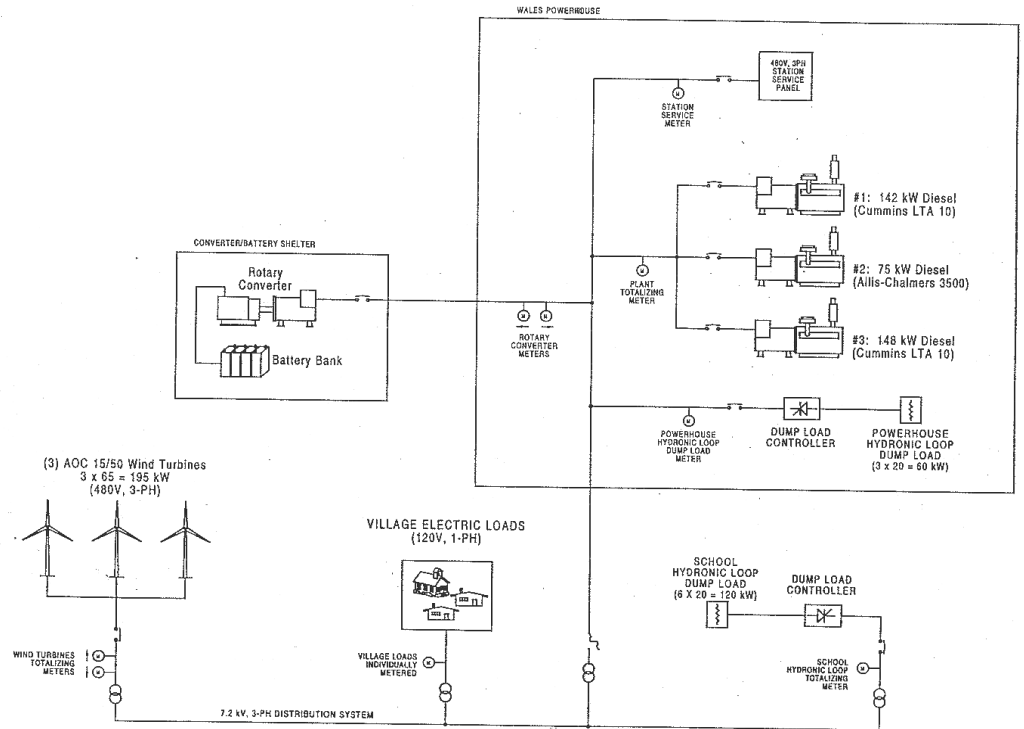

Figure 4. High penetration wind-diesel system (Wales, Alaska).

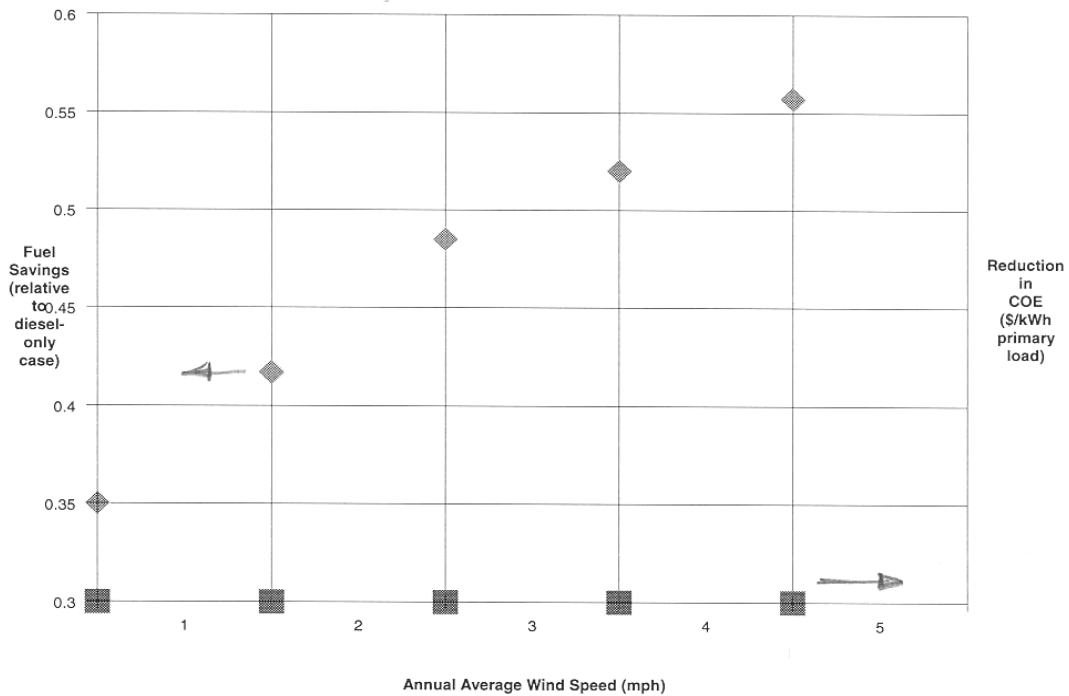

Figure 5. Fuel savings and levelized reduction in COE vs annual average wind speed (three wind turbines, fuel cost = \$0.48/1 [\$1.82/gal], storage size = 33.5 min at average load).

E. Institutional and Social Considerations

Rural electrification has had positive effect on agricultural and industrial productivity. There is a significant impact on agricultural mechanisation and irrigation through electric pump-sets. Also, there is a distinct positive effect on the quality of life in rural areas through the introduction of electricity, especially in the form of unimproved lighting, which results in longer hours of work, education, and recreation.

The market potential for small hybrid systems is in the tens of thousands, worldwide. One final comment—wind electric and PV generators, and their balance of systems, are very different from conventional generation equipment in many aspects, and therefore somewhat intimidating to the regional rural electricity provider. To make the transition to the comfort level of the village, the systems will need to perform as well as or better than the conventional solutions. Robustness, reliability, quality of service, and serviceability are the technical parameters that the local provider will be interested in evaluating. The performance data, including system, resource and load data, need to be collected, collaboratively analyzed, and reported to the project sponsors.

While the technical viability must be demonstrated, and economic comparisons should be made in the country context, the most significant value of the pilot projects is the development of the institutional viability. There have been countless renewable energy-based, donor-aided rural projects that made technical and (long-term) economic sense, but never were replicated, and in many cases became non-operational because care was not taken in the institutional aspects of the project.⁷ Renewable energy systems, like all energy systems, require administration, operational, and maintenance attention/discipline. The type of institution that will serve the rural electricity needs will depend on the local situation and the regional and national regulatory and legal structure.

F. Management and Implementation by Non-Government Organizations

A variety of institutional configuration may be considered for integration of renewable energy into village power, be it for domestic use, health care, agricultural applications or small industries. As observed by Jimenez and Olsen,⁵ the institutional configurations may include (1) management and implementation by government; (2) management by government and implementation by the private sectors, or (3) both management and implementation by non-government organizations (NGOs).

The advantage of NGOs are that most NGOs are run by committed and motivated individuals who operate effectively on limited budgets. NGOs also have strong community relationships and thus can generate community support and participate. Of course, NGOs who operate such hybrid systems should have individuals on their staff who have specialized skills to implement and monitor these systems.

Acknowledgement

This work was supported by the United States Department of Energy under Contract-DE-AC36-83CH10093.

References

1. Flowers, L., "Renewables for Sustainable Village Power," NREL/CP-440-22608, March 1997.
2. Lilienthal, P., Flowers, L., and Rossmann, C., "The Hybrid Optimization Model for Electric Renewables (HOMER)." *Windpower '95 Proceedings*, Washington, DC, 1995, pp. 475-479.
3. Baring-Gould, J., "Hybrid Power system Simulation Software, Hybrid 2," National Renewable Energy Lab., NREL/TP-440-21272, June 1996.
4. Schwartz, M., and Elliott, D., "The Integration of Climatic Data Sets for Wind Resource Assessment," American Meteorological Society, CP-440-23157, Oct. 1997.
5. Jimenez, A.C., and Olsen, Ken, "Renewable Energy for Rural Health Clinics," NREL/BK-500-25233, September 1998.
6. Shirazi, M., and Drouillet, S., "An Analysis of the Performance Benefits of Short-Term Energy Storage in Wind-Diesel Hybrid Power Systems," AIAA Paper 97-0947, Jan. 1997.
7. Touryan, K.J., "The U.S. Solar Route," *Geopolitics of Energy*, Vol. 6, 1984, pp. 4-9.